

MOBILE HOME PERMITS BECOME INVALID IF AN APPROVED INSPECTION IS NOT COMPLETED WITHIN 180 DAYS FROM THE DATE OF PERMIT ISSUANCE.

- 1. Review Process for Mobile Home Applications-** All of the information in this packet must be completely filled out. The packet is then submitted to the Building Department for review. When the review process is complete, the applicant will be contacted to then pull the Mobile Home Move On Permit. **Mobile Homes can only be set up by a Licensed Installer and the permits must be pulled by an authorized person.**
- 2. Used Mobile Homes.** All used mobile homes placed or relocated in Columbia County must have a pre-inspection form completed before the home is moved to the new location. Any homes that do not meet Wind Zone II or higher requirements can not be moved or set up in Columbia County. Most mobile homes built before 1976 do not meet these requirements therefore cannot be placed or set up in this county. When coming from another county, have that county Inspector complete our pre-inspection form or this form can be completed by a licensed private home inspector. Then return the form to the Building Department before the permit will be issued.
- 3. Environmental Health Permit or Sewer Tap Approval.** A copy of the Environmental Health signed site plan or a release must be submitted with your application. Contact them at (386) 758-1058
- 4. City Approval.** If the project is located within the city limits of Fort White, prior approval is required. The town of Fort White approval letter is required to be submitted to this office when applying for a Building Permit.
- 5. Ownership of Property.** Proof of ownership of the property is required, such as a recorded deed.
- 6. Parcel Number.** The parcel number (Tax ID number) from the Property Appraiser (386- 758-1084) is required. This may also be obtained on-line at www.columbiacountyfla.com then go to the Property Appraisers link then follow the screens.
- 7. 911 Address.** Contact 911 Addressing at (386) 752-8787, an example of the requirements to get the address are included.
- 8. Flood Information.** All projects within the Floodway of the Suwannee or Santa Fe Rivers shall require permitting through the Suwannee River Water Management District, before submitting to our office. Any project located within a flood zone where the base flood elevation (100year flood) has been established shall meet the requirements of Section 8.8 of the Columbia County Land Development Regulations. Any project located within a flood zone where the base flood elevation (100year flood) has not been established shall meet the requirements of section 8.7 of the Columbia County Land Development Regulations. **Certified Finished Floor Elevations Will Be Required On Any Project Where The Base Flood Elevation (100 year flood) Has Been Established.** A development permit will also be required (\$50.00) fee. All dwellings must be placed one foot above the adjacent roadway or a floor height letter submitted from a licensed Engineer.
- 9. (a) Cost of Mobile Home Permit.** The fee associated with your size Mobile home , plus a \$75.00 Zoning & Flood fee, plus the current Special Assessment fees. Plus Impact Fees if applicable. **(b) Special Assessment Fees.** For Fire and Solid Waste, it is prorated monthly. **(c) Impact fees-** Suspended as of March 2009 until further notice.
- 10. Driveway Connection.** If the property does not have an existing access to a county maintained public road, then you must apply for culvert permit (\$25.00) or a culvert waiver (\$50.00) if you feel that a culvert is not needed. The waiver is either approved or denied by the Columbia County Public Works Department. If the property will have access from a state maintained road, then an approved application for driveway access from F.D.O.T. must be submitted before a permit will be issued. **No release of final power** will be given until driveway access is complete and given final inspection approval by the appropriate department.
- 11. Private Wells.** The well driller has to give you a letter on your well, stating (a) size of pump motor (b) size of pressure tank (c) cycle stop valve if used. This letter should be on there letterhead. Any questions on this contact (386) 758-1008.
- 12. Site Plan.** Draw the property with the mobile home where it is going to be placed. Show the actual distance from each property line to the mobile home. Show existing roads and the driveway location. Show all other buildings and residences on the property, list the distance from these to the new mobile home. Show the location of the well and list existing or new.

PERMIT APPLICATION / MANUFACTURED HOME INSTALLATION APPLICATION

<u>For Office Use Only</u> (Revised 1-10-08)	Zoning Official _____	Building Official _____		
AP# _____	Date Received _____	By _____	Permit # _____	
Flood Zone _____	Development Permit _____	Zoning _____	Land Use Plan Map Category _____	
Comments _____				
FEMA Map# _____	Elevation _____	Finished Floor _____	River _____	In Floodway _____
<input type="checkbox"/> Site Plan with Setbacks Shown	<input type="checkbox"/> EH # _____	<input type="checkbox"/> EH Release	<input type="checkbox"/> Well letter	<input type="checkbox"/> Existing well
<input type="checkbox"/> Recorded Deed or Affidavit from land owner	<input type="checkbox"/> Letter of Auth. from installer	<input type="checkbox"/> State Road Access		
<input type="checkbox"/> Parent Parcel # _____	<input type="checkbox"/> STUP-MH _____	<input type="checkbox"/> F W Comp. letter		
IMPACT FEES: EMS _____	Fire _____	Corr _____	Road/Code _____	
School _____	= TOTAL _ Impact Fees Suspended March 2009_			

Property ID # _____ Subdivision _____

- New Mobile Home _____ Used Mobile Home _____ MH Size _____ Year _____
- Applicant _____ Phone # _____
- Address _____
- Name of Property Owner _____ Phone# _____
- 911 Address _____
- Circle the correct power company - FL Power & Light - Clay Electric
(Circle One) - Suwannee Valley Electric - Progress Energy
- Name of Owner of Mobile Home _____ Phone # _____
- Address _____
- Relationship to Property Owner _____
- Current Number of Dwellings on Property _____
- Lot Size _____ Total Acreage _____
- Do you : Have Existing Drive or Private Drive or need Culvert Permit or Culvert Waiver (Circle one)
(Currently using) (Blue Road Sign) (Putting in a Culvert) (Not existing but do not need a Culvert)
- Is this Mobile Home Replacing an Existing Mobile Home _____
- Driving Directions to the Property _____
- _____
- _____
- _____
- Name of Licensed Dealer/Installer _____ Phone # _____
- Installers Address _____
- License Number _____ Installation Decal # _____

SECTION III. MINIMUM STANDARDS

1. No manufactured home or recreational vehicle shall be issued a permit for occupancy as a permanent residence unless it has a minimum of 450 square feet of net living area (not including garages, carports, porches, balconies, storage areas or cabanas). It shall be unlawful to join together two or more such homes for residential purposes when not intended by the manufacturer.
2. No manufactured home or recreational vehicle shall be issued a permit for occupancy as a permanent residence in Columbia County unless it measures at least 10 feet in width, including attached additions.
3. No new or used manufactured home or recreational vehicle shall be issued a permit for setting up or occupancy as a permanent residence unless the same shall meet at least one of the following codes:
 - a. The Federal Mobile Home Construction and Safety Standards for single family mobile homes, promulgated by the Department of Housing and Urban Development; or
 - b. The Uniform Standards Code approved by the United States of American Standards Institute (ANSI Code) for duplex mobile homes; or
 - c. The Uniform Standards Code approved by American National Standards Institute (ANSI Code); or
 - d. The minimum housing code of Columbia County, if applicable; and meet the following requirements :
 - (1) The unit is in clean and sound condition; and
 - (2) All windows are in place with no broken panes; and
 - (3) The unit has and operates from an electric meter separate from any other unit.
 - (4) The outdoor electrical panel box is in proper working order and the service entrance conductors are no less #8 gauge aluminum wire or equivalent copper; and
 - (5) All heating equipment where applicable is or appears to be in proper working order; and
 - (6) At least one set of steps providing access to the unit is in place; and
 - (7) All exterior doors and door hardware are in place; and
 - (8) Properly working washing machine connections are in place, if applicable; and
 - (9) There are smoke alarm systems, which is or appears to be in proper working order.
4. All permits issued pursuant to this Ordinance or a copy thereof shall be displayed in the window next to the front door of the manufactured home or recreational vehicle.
5. All used mobile homes placed or relocated in Columbia County must have a pre-inspection form completed before home is moved to the new location. Any homes that do not meet wind zone ii or higher requirements can not be moved into Columbia County. Most homes built before 1976 do not meet wind zone II requirements therefore cannot be placed or set up in Columbia County.

FINAL POWER RELEASE FOR MOBILE HOMES

- 1.** The final inspection of blocking, tie downs, electrical, plumbing, and culvert / driveway connection, must be requested and passed. Please call the Columbia County Building Department at (386)758-1008 to request an inspection. Make sure you have the permit number when you call. Please call and give at least 24 hours notice. All inspections are to be scheduled and made at one time, including the Certificate of Occupancy.
- 2.** The final septic tank approval must be given to the Columbia County Building Department. Please contact the Columbia County Environmental Health Department (386) 758-1058 to request final inspection on septic tank and to have septic tank release given to Building Department.
- 3.** If your permit required a Development permit, we will need a certified finished floor elevation from the surveyor before the power can be release.

COLUMBIA COUNTY PERMIT WORKSHEET

**These worksheets must be completed and signed by the installer.
Submit the originals with the packet.**

Installer _____ License # _____

911 Address where home is being installed. _____

Manufacturer _____ Length x width _____

**NOTE: if home is a single wide fill out one half of the blocking plan
if home is a triple or quad wide sketch in remainder of home**

I understand Lateral Arm Systems cannot be used on any home (new or used)
where the sidewall ties exceed 5 ft 4 in.

Installer's initials _____

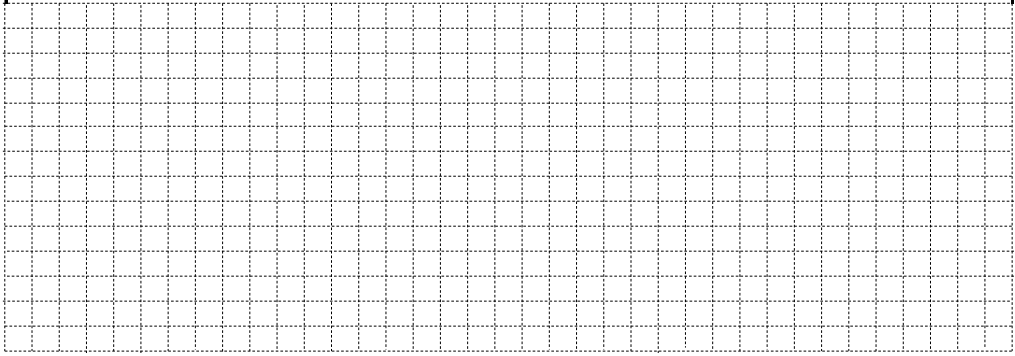
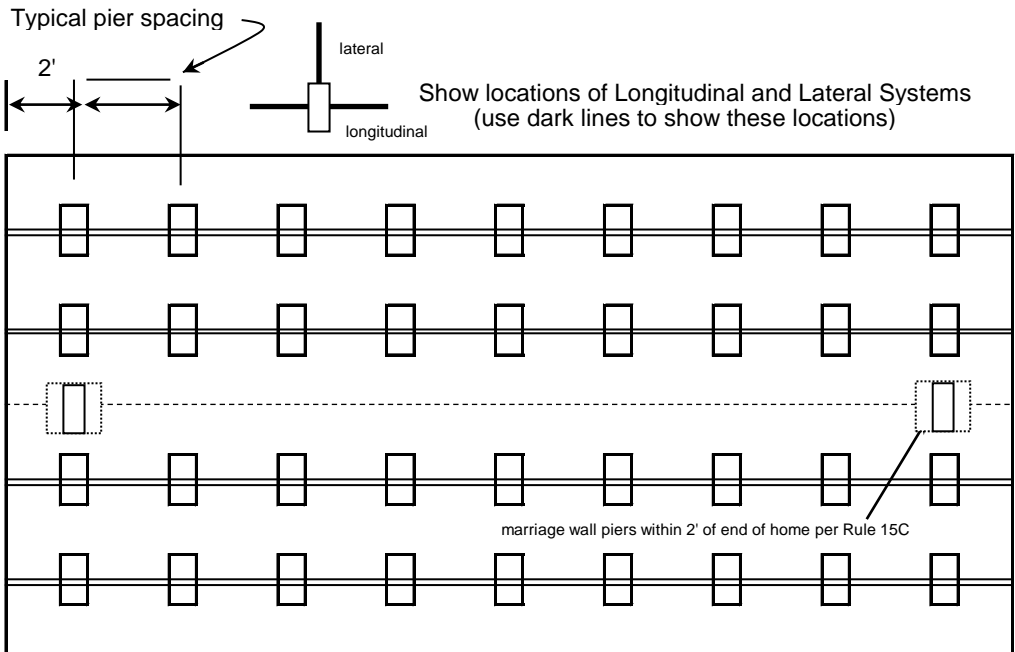

New Home Used Home

Home installed to the Manufacturer's Installation Manual

Home is installed in accordance with Rule 15-C

Single wide Wind Zone II Wind Zone III

Double wide Installation Decal # _____

Triple/Quad Serial # _____

PIER SPACING TABLE FOR USED HOMES

Load bearing capacity	Footer size (sq in)	16" x 16" (256)	18 1/2" x 18 1/2" (342)	20" x 20" (400)	22" x 22" (484)*	24" X 24" (576)*	26" x 26" (676)
1000 psf		3'	4'	5'	6'	7'	8'
1500 psf		4' 6"	6'	7'	8'	8'	8'
2000 psf		6'	8'	8'	8'	8'	8'
2500 psf		7' 6"	8'	8'	8'	8'	8'
3000 psf		8'	8'	8'	8'	8'	8'
3500 psf		8'	8'	8'	8'	8'	8'

* interpolated from Rule 15C-1 pier spacing table.

PIER PAD SIZES

I-beam pier pad size _____

Perimeter pier pad size _____

Other pier pad sizes (required by the mfg.) _____

Draw the approximate locations of marriage wall openings 4 foot or greater. Use this symbol to show the piers.

List all marriage wall openings greater than 4 foot and their pier pad sizes below.

Opening	Pier pad size
_____	_____
_____	_____
_____	_____

TIEDOWN COMPONENTS

Longitudinal Stabilizing Device (LSD)
 Manufacturer _____
Longitudinal Stabilizing Device w/ Lateral Arms
 Manufacturer _____

POPULAR PAD SIZES

Pad Size	Sq In
16 x 16	256
16 x 18	288
18.5 x 18.5	342
16 x 22.5	360
17 x 22	374
13 1/4 x 26 1/4	348
20 x 20	400
17 3/16 x 25 3/16	441
17 1/2 x 25 1/2	446
24 x 24	576
26 x 26	676

ANCHORS

4 ft _____ 5 ft _____

FRAME TIES

within 2' of end of home _____
 spaced at 5' 4" oc _____

OTHER TIES

	Number
Sidewall	_____
Longitudinal	_____
Marriage wall	_____
Shearwall	_____

POCKET PENETROMETER TEST

The pocket penetrometer tests are rounded down to _____ psf or check here to declare 1000 lb. soil _____ without testing.

X _____ X _____ X _____

POCKET PENETROMETER TESTING METHOD

1. Test the perimeter of the home at 6 locations.
2. Take the reading at the depth of the footer.
3. Using 500 lb. increments, take the lowest reading and round down to that increment.

X _____ X _____ X _____

TORQUE PROBE TEST

The results of the torque probe test is _____ inch pounds or check here if you are declaring 5' anchors without testing _____. A test showing 275 inch pounds or less will require 5 foot anchors.

Note: A state approved lateral arm system is being used and 4 ft. anchors are allowed at the sidewall locations. I understand 5 ft anchors are required at all centerline tie points where the torque test reading is 275 or less and where the mobile home manufacturer may requires anchors with 4000 lb holding capacity.

_____ Installer's initials

ALL TESTS MUST BE PERFORMED BY A LICENSED INSTALLER

Installer Name _____

Date Tested _____

Electrical

Connect electrical conductors between multi-wide units, but not to the main power source. This includes the bonding wire between multi-wide units. Pg. _____

Plumbing

Connect all sewer drains to an existing sewer tap or septic tank. Pg. _____

Connect all potable water supply piping to an existing water meter, water tap, or other independent water supply systems. Pg. _____

Site Preparation

Debris and organic material removed _____.
Water drainage: Natural _____ Swale _____ Pad _____ Other _____.

Fastening multi wide units

Floor: Type Fastener: _____ Length: _____ Spacing: _____
Walls: Type Fastener: _____ Length: _____ Spacing: _____
Roof: Type Fastener: _____ Length: _____ Spacing: _____
For used homes a min. 30 gauge, 8" wide, galvanized metal strip will be centered over the peak of the roof and fastened with galv. roofing nails at 2" on center on both sides of the centerline.

Gasket (weatherproofing requirement)

I understand a properly installed gasket is a requirement of all new and used homes and that condensation, mold, mildew and buckled marriage walls are a result of a poorly installed or no gasket being installed. I understand a strip of tape will not serve as a gasket.

Installer's initials _____

Type gasket _____ Installed:
Pg. _____ Between Floors Yes _____
Between Walls Yes _____
Bottom of ridgebeam Yes _____

Weatherproofing

The bottomboard will be repaired and/or taped. Yes _____ Pg. _____
Siding on units is installed to manufacturer's specifications. Yes _____
Fireplace chimney installed so as not to allow intrusion of rain water. Yes _____

Miscellaneous

Skirting to be installed. Yes _____ No _____
Dryer vent installed outside of skirting. Yes _____ N/A _____
Range downflow vent installed outside of skirting. Yes _____ N/A _____
Drain lines supported at 4 foot intervals. Yes _____
Electrical crossovers protected. Yes _____
Other : _____

Installer verifies all information given with this permit worksheet is accurate and true based on the

Installer Signature _____ Date _____