



COLUMBIA COUNTY BOARD OF COUNTY COMMISSIONERS AGENDA ITEM REQUEST FORM

The Board of County Commissioners meets the 1st and 3rd Thursday of each month in the Columbia County School Board Administrative Complex Auditorium, 372 West Duval Street, Lake City, Florida 32055. The first meeting of every month is at 9:30AM while the second meeting of every month takes place at 5:30PM. All agenda items are due in the Board's office one week prior to the meeting date.

Today's Date: 11/13/2025 Meeting Date: 11/20/2025

Department: Public Works

1. Nature and purpose of agenda item:

Utility Permit from WANrack requesting to install a cable on SW High St.

2. Recommended Motion/Action:

Approve

3. Fiscal impact on current budget.

This item has no effect on the current budget.

**COLUMBIA COUNTY BOARD OF COUNTY COMMISSIONERS
UTILITY PERMIT**

Date: _____ Permit No. 250156 County Road SW HIGH ST Section No. _____

Permittee WANRack

Address 4550 W 109th St, Overland Park, KS 66211 Telephone Number 301-752-6692

Requesting permission from Columbia County, Florida, hereinafter called the County, to contract, operate and maintain UNDERGROUND PLACEMENT OF (1) 2" HDPE DUCT WITH 24CT FOC. ALONG SW HIGH ST FOR APPROX. 753'.

FROM: US-41 TO: US-441

Submitted for the Utility Owner by: Carrie Namias - KCI Technologies
 Typed Name & Title Signature Date

Carrie Namias
Digitally signed by Carrie Namias
 DN: cn=Carrie Namias, o=KCI
 Technologies, ou, email=Carrie.Namias@
 CWI9KI.com, c=US
 Date: 2025.10.30.16:31:46 -0400

1. Permittee declares that prior to filing this application it has determined the location of all existing utilities, both aerial and underground and the accurate locations are shown on the plans attached hereto and made a part of this application. Proposed work is within corporate limits of Municipality: YES () NO (). If YES: LAKE CITY () FORT WHITE (). A letter of notification was mailed on 10/30/2025 to the following utility owners: AT & T, CITY OF LAKE CITY UTILS, COMCAST CABLE COMMUNICATIONS, FLORIDA POWER & LIGHT-COLUMBIA, FLORIDA UTILITY SERVICES

1LLC SUWANEE VALLEY COUNTRY DALE, FLORIDA UTILITY SERVICES 1LLC SUWANEE VALLEY WOOD GATE

2. The Columbia County Public Works Director shall be notified twenty-four (24) hours prior to starting work and again immediately upon completion of work. The Public Works Director is Kevin Kirby, located at 607 NW Quinten St. Lake City, FL 32025 Telephone Number 386-758-1019. The PERMITTEE's employee responsible for Maintenance of Traffic is Ryan Hook Telephone Number 240-346-9956 (This name may be provided at the time of the 24 hour notice to starting work.)

3. This PERMITTEE shall commence actual construction in good faith within 60 days after issuance of permit, and shall be completed within 20 days after permitted work has begun. If the beginning date is more than 60 days from date of permit approval, then PERMITTEE must review the permit with the Columbia County Public Works Director to make sure no changes have occurred in the transportation facility that would affect the permitted construction.

4. The construction and maintenance of such utility shall not interfere with the property and rights of a prior PERMITTEE.

5. It is expressly stipulated that this permit is a license for permissive use only and that the placing of utilities upon public property pursuant to this permit shall not operate to create or vest any property right in said holder.

6. Pursuant to Section 337-403(1), Florida Statutes, whenever necessary for the construction, repair, improvement, maintenance, safe and efficient operation, alteration or relocation of all, or any portion of said transportation facility as determined by the Columbia County Public Works Director and/or County Engineer, any or all utilities and appurtenances authorized hereunder, shall be immediately removed from said transportation facility or reset or

relocated thereon as required by the Columbia County Public Works Director and/or County Engineer and at the expense of the PERMITTEE.

7. In case of non-compliance with the County's requirements in effect as of the approval date of this permit, this permit void and the facility will have to be brought into compliance or removed from the right of way at no cost to the County.

8. It is understood and agreed that the rights and privileges herein set out are granted only to the extent of the County's right, title and interest in the land to be entered upon and used by the PERMITTEE, and the PERMITTEE will, at all times, and to the extent permitted by law, assume all risk of and indemnify, defend, and save harmless Columbia County, Florida from any and all loss, damage, cost or expense arising in any manner on account of the exercise or attempted exercise by said PERMITTEE of the aforesaid right and privileges.

9. During construction, all safety regulations of the County shall be observed and the PERMITTEE must take measures, including pacing and the display of safety devices that may be necessary in order to safely conduct the public through the project area in accordance with the Federal Manual on Uniform Traffic Control Devices, as amended for highways.

10. Should the PERMITTEE be desirous of keeping its utilities in place and out of service, the PERMITTEE, by execution of this permit acknowledges its present and continuing ownership of its utilities located between US-41 _____ and US-441 _____ within the County's right of way as set forth above. PERMITTEE, as its sole expense, shall promptly remove said out of service utilities whenever Columbia County Public Works Director and/or County Engineer determines said removal is in the public interest.

11. Special instructions: Minimum cover of thirty inches (30") will be required at all locations. Columbia County will not be financially responsible for any damage to facilities with less than thirty inches (30") cover. Cables shall not be located within driveway ditches.

12. Additional Stipulations: _____

* Contact Ken Sweet (386) 466-8037 before start of work onsite.

It is understood and agreed that commencement by the PERMITTEE is acknowledgment and acceptance of the binding nature of these specialist instructions.

Submitted By: WANRack, LLC
Permittee

Place Corporate Seal

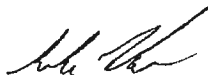
Caulan Brooks,
GIS Design Team Manager
Signature and Title

Cole Campbell,
Designer
Attested

Utilities Permit
Page three
Revised: 8/17/00

Recommended for Approval:

Signature: _____
Title: _____
Date: _____

Approval by Board of County Commissioners, Columbia County, Florida:

YES () NO ()

Date Approved: _____

Chairman's Signature: _____

00001927_012 Col_CR_HighSt_UG_1



**Know what's below.
Call before you dig.**

REVISIONS		
DATE	DESCRIPTIONS	BY:
10-16-25	PRELIMINARY DESIGN	

CONSTRUCTION FIRM	
MANAGER	#
PHONE	#



KCI TECHNOLOGIES INC.
 150 KELSEY LN.
 TAMPA, FL 33619
 TEL 813-740-2300
 FAX 813-740-0158
 www.kci.com



COLUMBIA COUNTY SCHOOLS PROJECT
COL_CR_HIGHST_UG_1
00001927_012

SHEET NAME	COL_CR_HIGHST_UG_1	CONTACT	R TURNER	REVISION	0
TOWN-STATE	LAKE CITY, FL	COUNTY	COLUMBIA	SHEET	1 OF 2

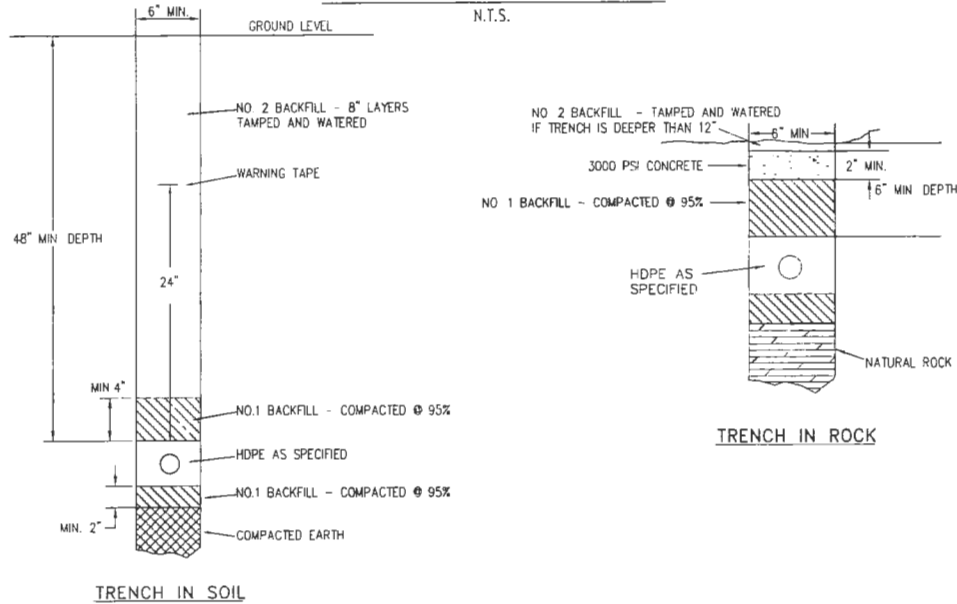
TYPICAL TRENCH:



- CONSTRUCTION NOTES:**
- NO. 1 BACKFILL WILL BE CLEAN NATURAL SAND WHICH IS FREE OF DEBRIS AND HAS BEEN SIEVED THROUGH A NO. 16 SEIVE. PULVERIZED CLAY WILL NOT BE USED.
 - NO. 2 BACKFILL WILL BE EARTH WHICH IS FREE FROM DEBRIS, CINDERS AND ROCKS MEASURING 4 INCHES. (10CM), OR GREATER ACROSS THEIR LARGEST DIMENSION.
 - A WATERPROOF SEALING PLUG WILL BE AROUND THE FIBER OPTIC CABLE TO SEAL THE OPENING IN THE CONDUIT.
 - A MINIMUM OF 6" OF NO.1 BACKFILL SHALL COVER THE CONDUIT IN THE AREAS OF HANDHOLE EXCAVATION. THIS COVER WILL TRANSITION TO 4" AROUND TRENCHING EXCAVATION.



Know what's below.
Call before you dig.

REVISIONS		
DATE	DESCRIPTIONS:	BY
10-16-25	PRELIMINARY-DESIGN	

CONSTRUCTION FIRM	
MANAGER:	#
PHONE:	#

KCI
 KCI TECHNOLOGIES INC.
 150 KELSEY LN
 TAMPA FL 33619
 TEL 813-740-2300
 FAX 813-740-0158
 WWW.KCI.COM



COLUMBIA COUNTY SCHOOLS PROJECT
 COL_CR_HIGHST_UG_1
 00001927_012

SHEET NAME	COL_CR_HIGHST_UG_1	CONTACT	R TURNER	REVISION	0
TOWN-STATE	LAKE CITY FL	COUNTY	COLUMBIA	SHEET	10 OF 2

TYPICAL BORE:

N.T.S.

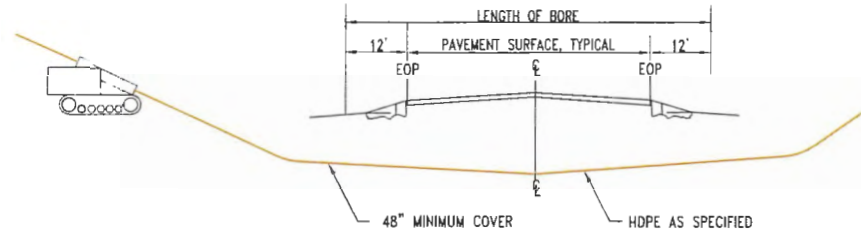
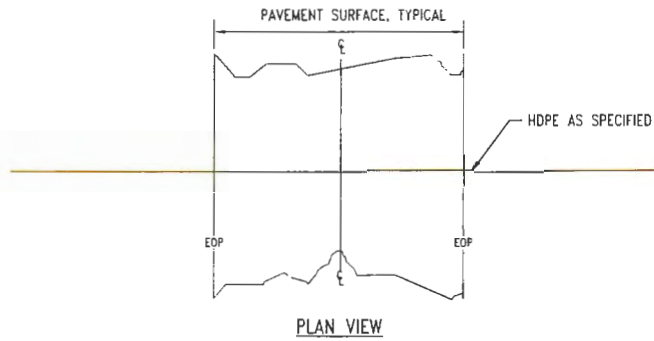

TYPICAL PROFILE/BORE REQUIREMENTS
PLACING CONDUIT

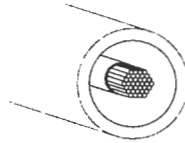

TYPICAL CONDUIT REQUIREMENTS
COUNT FIBER AS SPECIFIED



Know what's below.
Call before you dig.

REVISIONS		
DATE	DESCRIPTIONS	BY
10-16-23	PRELIMINARY-DESIGN	

CONSTRUCTION FIRM	
MANAGER	#
PHONE	#

KCI
KCI TECHNOLOGIES INC.
150 KELSEY LN.
TAMPA, FL 33619
TEL 813-740-2300
FAX 813-740-0158
www.kci.com

WANRack™

COLUMBIA COUNTY SCHOOLS PROJECT
COL_CR_HIGHEST_UG_1
00001927_012

SHEET NAME	COL_CR_HIGHEST_UG_1	CONTACT	R. TURNER	REVISION	0
TOWN-STATE	LAKE CITY, FL	COUNTY	COLUMBIA	SHEET	1E OF 2

TYPICAL UTILITY CROSSING:

N.T.S.

UTILITY CROSSING DETAIL

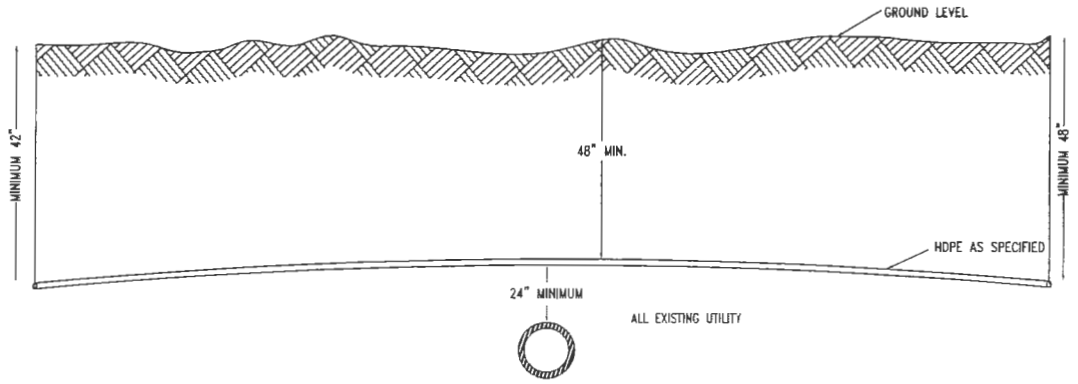
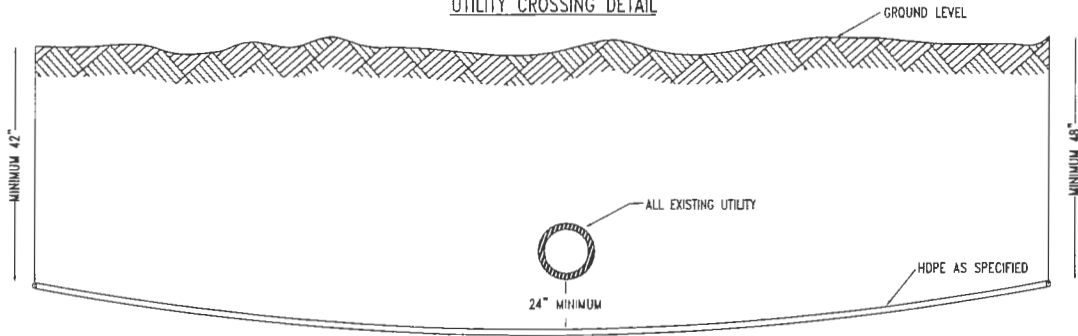

UTILITY CROSSING DETAIL
STORM CULVERTS

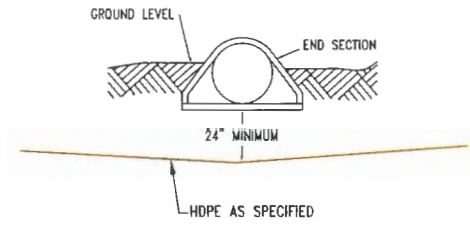
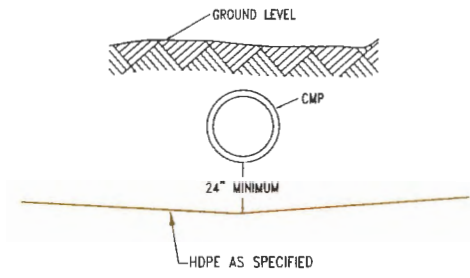

DITCHLINE DETAIL

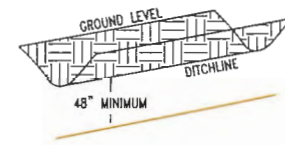

NOTES:

1. A MINIMUM OF 24" SEPARATION IS REQUIRED BY OTHER UTILITY COMPANIES.
2. UTILITIES INCLUDE BUT ARE NOT LIMITED TO WATER, GAS, SEWER AND POWER.



Know what's below.
Call before you dig.

REVISIONS		
DATE	DESCRIPTIONS.	BY.
10-16-25	PRELIMINARY DESIGN	

CONSTRUCTION FIRM	
MANAGER	#
PHONE	#

KCI
KCI TECHNOLOGIES INC.
150 KELSEY LN.
TAMPA, FL 33619
TEL 813-740-2300
FAX 813-740-0158
www.kci.com



COLUMBIA COUNTY SCHOOLS PROJECT
COL_CR_HIGHST_UG_1
00001927_012

SHEET NAME	COL_CR_HIGHST_UG_1	CONTACT	R TURNER	REVISION	0
TOWN-STATE	LAKE CITY FL	COUNTY	COLUMBIA	SHEET	1F OF 2

24" X 36" X 30" HANDHOLE DETAIL

N.T.S.

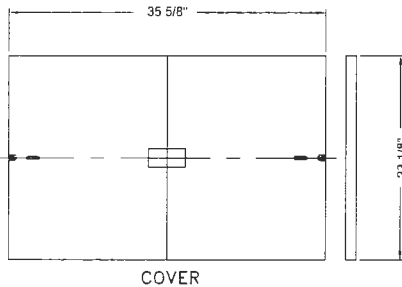
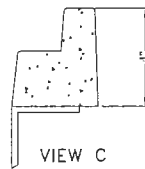
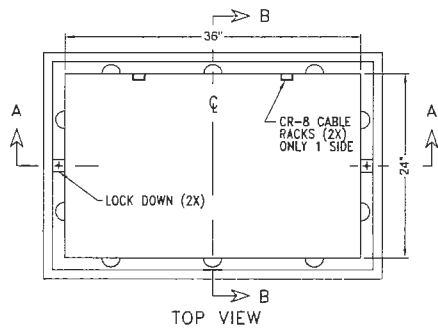
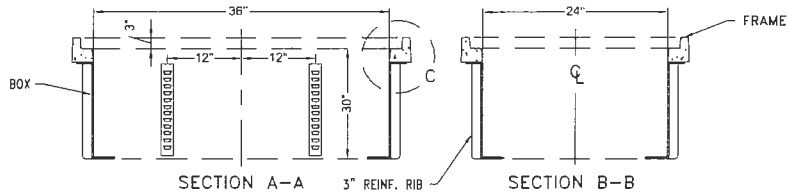

1. PLACE 6" OF 3/4" CRUSHED ROCK IN THE BOTTOM OF THE EXCAVATION.
2. WIRE MESH (TWO SQUARES PER INCH) SHALL BE PLACED OVER THE ROCK. IT WILL BE NECESSARY TO CUT OPENINGS FOR HDPE IN WIRE MESH.
3. HANDHOLE WILL BE SET FLUSH WITH EXISTING GRADE AND IN LINE WITH & CENTERED OVER R/L & BACKFILLED AS PER TYPICAL.
4. HDPE SDR 11 CONDUIT SHALL BE PLACED IN THE CORNERS OF HANDHOLE.
5. TERMINATE THE HDPE CONDUIT A MINIMUM OF SIX (6) INCHES ABOVE THE WIRE MESH. DO NOT TERMINATE HDPE SDR 11 CONDUIT MORE THAN EIGHT (8) INCHES ABOVE THE WIRE MESH.
6. PLACE EXPANSION PLUGS IN ALL CONDUITS.
7. 95% COMPACTION IN 6" LIFTS OR 2 SACK MIX AROUND HANDHOLE.
8. NO HANDHOLES ARE TO BE PLACED WITHIN THE DITCHLINE.

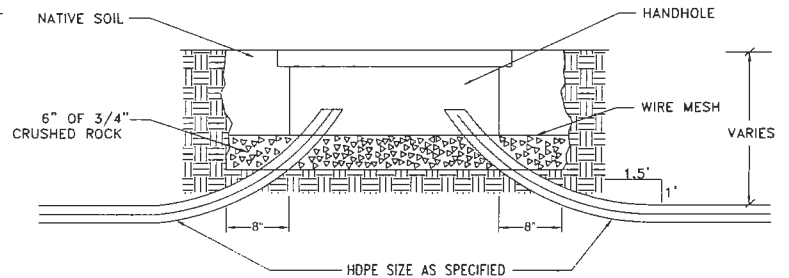
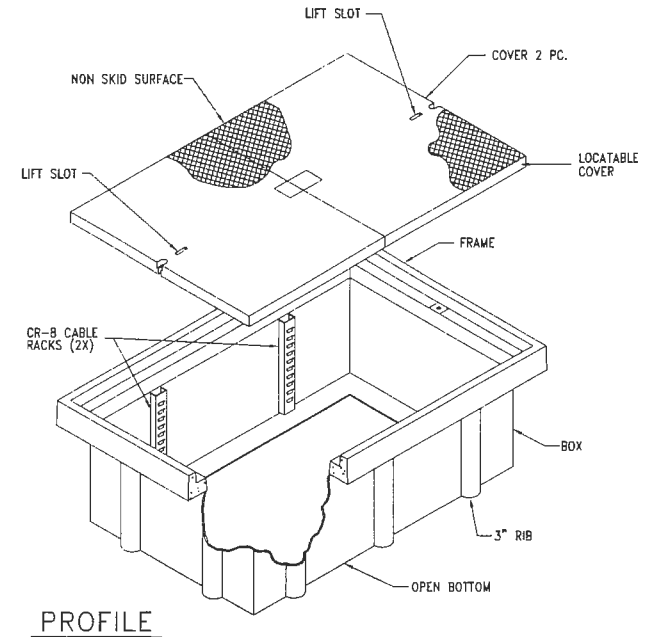

REVISIONS		
DATE	DESCRIPTIONS	BY
10-10-25	PRELIMINARY DESIGN	

CONSTRUCTION FIRM	
MANAGER	#
PHONE	#

KCI
 KCI TECHNOLOGIES INC.
 150 KELSEY LN.
 TAMPA, FL 33619
 TEL 813-740-2300
 FAX 813-740-0158
 www.kci.com



COLUMBIA COUNTY SCHOOLS PROJECT				
COL_CR_HIGHST_UG_1				
00001927_012				
SHEET NAME	COL_CR_HIGHST_UG_1	CONTACT	R TURNER	REVISION 0
TOWN-STATE	LAKE CITY, FL	COUNTY	COLUMBIA	SHEET 1G OF 2



SCALE 1:50

NOTES
 WHEN PULLING FIBER-OPTIC CABLE, PLACE A PULL STRING FOR FUTURE USE
 ALL HANDHOLES ARE TO BE FLUSH MOUNTED
 ALL CONSTRUCTION WITHIN RIGHT OF WAYS TO BE IN ACCORDANCE WITH STATE/COUNTY/CITY REQUIREMENTS
 CAUTION
 RIGHTS-OF-WAY ARE DEPICTED BASED ON FIELD OBSERVATION AND THE LATEST COUNTY RECORDS AVAILABLE. IF FURTHER ACCURACY IS REQUIRED, LAND SURVEYS WILL BE NECESSARY



REVISIONS		
DATE	DESCRIPTIONS	BY
APPROVED	PRELIMINARY DESIGN	R TURNER

CONSTRUCTION FIRM	
MANAGER	R
PHONE	Z

KCI
 KCI TECHNOLOGIES INC.
 150 KELSEY LN.
 TAMPA, FL 33619
 TEL 813-740-2300
 FAX 813-740-0158
 www.kci.com



COLUMBIA COUNTY SCHOOLS PROJECT
 COL_CR_HIGHST_UG_1
 00001927_012

SHEET NAME	COL_CR_HIGHST_UG_1	DRAFTER	R TURNER	REVISION	0
TOWN/STATE	LAKE CITY FL	COUNTY	COLUMBIA	SHEET	2 OF 2



SCALE 1" = 50'

NOTES
 WHEN PULLING FIBER-OPTIC CABLE, PLACE A PULL STRING FOR FUTURE USE
 ALL HANDHOLES ARE TO BE FLUSH MOUNTED
 ALL CONSTRUCTION WITHIN RIGHT OF WAYS TO BE IN ACCORDANCE WITH STATE/COUNTY/CITY REQUIREMENTS
 CAUTION
 RIGHTS-OF-WAY ARE DEPICTED BASED ON FIELD OBSERVATION AND THE LATEST COUNTY RECORDS AVAILABLE. IF FURTHER ACCURACY IS REQUIRED LAND SURVEYS WILL BE NECESSARY



REVISIONS		
DATE	DESCRIPTIONS	BY
08/08/2008	PRELIMINARY DESIGN	R. TURNER

CONSTRUCTION FIRM	
MANAGER	#
PHONE	#

KCI
 KCI TECHNOLOGIES INC.
 150 KELSEY LN.
 TAMPA, FL 33619
 TEL 813-740-2300
 FAX 813-740-0158
 WWW.KCI.COM



COLUMBIA COUNTY SCHOOLS PROJECT					
COL_CR_HIGHEST_UG_1					
00001927_012					
SHEET NAME	COL_CR_HIGHEST_UG_1	DRAFTER	R TURNER	REVISION	0
TOWN-STATE	LAKE CITY FL	COUNTY	COLUMBIA	SHEET	3 OF 2

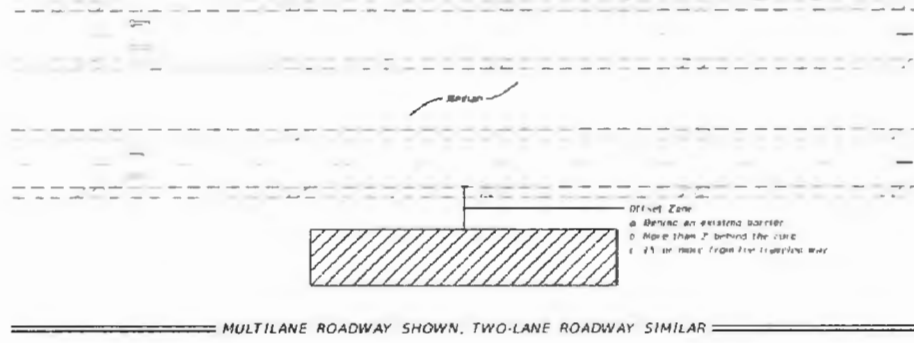

NOTES:

- 1 This Index applies to Two-Lane Two-Way and Multilane Roadways including Networks of divided roadways with work beyond the shoulder.
- 2 Use Index 102-602 when the work location includes an existing and proposed in the work area requires that two or more work vehicles occupy the Drive Zone in any one hour period.
- 3 Use Index 102-660 when work Area encroaches a Shoulder.

SYMBOLS:

- Work Area
- Lane Identification and Direction of Traffic

L457 REVISION 11/01/20	DESCRIPTION		FY 2025-26 STANDARD PLANS	TWO-LANE AND MULTILANE ROADWAY, WORK BEYOND THE SHOULDER	INDEX 102-601	SHEET 1 of 1
------------------------------	-------------	--	------------------------------	---	------------------	-----------------



REVISIONS		
DATE	DESCRIPTIONS	BY
10-16-25	PRELIMINARY DESIGN	

CONSTRUCTION FIRM	
MANAGER	#
PHONE	#

KCI TECHNOLOGIES INC.
 150 KELSEY LN.
 TAMPA, FL 33619
 TEL 813-740-2300
 FAX 813-740-0198
 www.kci.com



COLUMBIA COUNTY SCHOOLS PROJECT COL_CR_HIGHST_UG_1 00001927_012			
SHEET NAME	COL_CR_HIGHST_UG_1	CONTACT	R. TURNER
TOWN-STATE	LAKE CITY, FL	COUNTY	COLUMBIA
REVISION	0	SHEET	102-601(1) OF 2

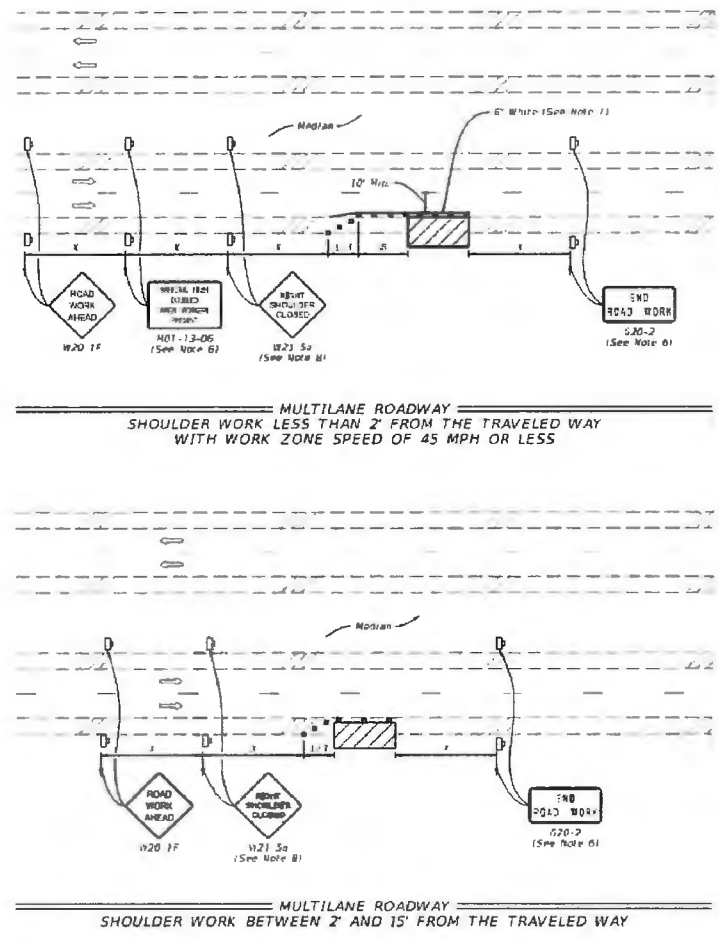

SYMBOLS:
 Work Area
 Channelizing Device (See Index 102-600)
 Work Zone Sign
 Lane Identification and Direction of Traffic

LAST REVISION 11/01/20	DESCRIPTION	FDOT	FY 2025-26 STANDARD PLANS	TWO-LANE AND MULTILANE WORK ON SHOULDER	INDEX 102-602	SHEET 2 of 2
---------------------------	-------------	------	------------------------------	---	------------------	-----------------



DATE	REVISIONS	DESCRIPTIONS	BY:
10-18-25		PRELIMINARY DESIGN	

CONSTRUCTION FIRM	
MANAGER	#
PHONE	#

KCI
 KCI TECHNOLOGIES INC.
 150 KELSEY LN
 TAMPA, FL 33619
 TEL 813-740-2300
 FAX 813-740-0158
 www.kci.com



COLUMBIA COUNTY SCHOOLS PROJECT COL_CR_HIGHST_UG_1 00001927_012					
SHEET NAME	COL_CR_HIGHST_UG_1	CONTACT	R TURNER	REVISION	0
TOWN-STATE	LAKE CITY, FL	COUNTY	COLUMBIA	SHEET	102-602(2) OF 2

GENERAL NOTES:

- 1 This Index applies to one-lane, two-way roadways with work within or near the intersection.
- 2 **W** = Work Zone Sign Spacing
See Index 102-600 for "W" and channelizing device spacing values.
- 3 Occasionally use "Flagging Ahead" sign with text (W20-7A) instead of "Flagging Ahead" sign with symbol (W20-7).
- 4 If vehicles in a parking zone block the line of sight, TCZ signs, (locate and) must mount signs in accordance with Index 700-101.
- 5 If the work area extends across a crosswalk, use the crosswalk in accordance with Index 102-660.
- 6 For unsignalized intersections, use Temporary Raised Bumble Stripes in accordance with Index 102-601. Placement of **W** signs, stripes and additional signs should begin at **FLAGGER** sign location.
- 7 The "End Road Work" signs (S20-2) along with the **W** signs, work zone sign distances may be similar when the work zone will be in place for 24 hours or less.
- 8 As an option to the "STOP" sign (R1-1) and Restriction Let/Right Turnup Movement sign (R3-1) or R3-2, the "SIDE ROAD INTERSECTS THE WORK ZONE" flagging variation from Index 102-600 may be used.

SYMBOLS:

- Work Area
- Channelizing Device (See Index 102-600)
- Work Zone Sign
- Type III Barricade
- Stop Bar
- Flagger
- Lane Identification and Direction of Traffic

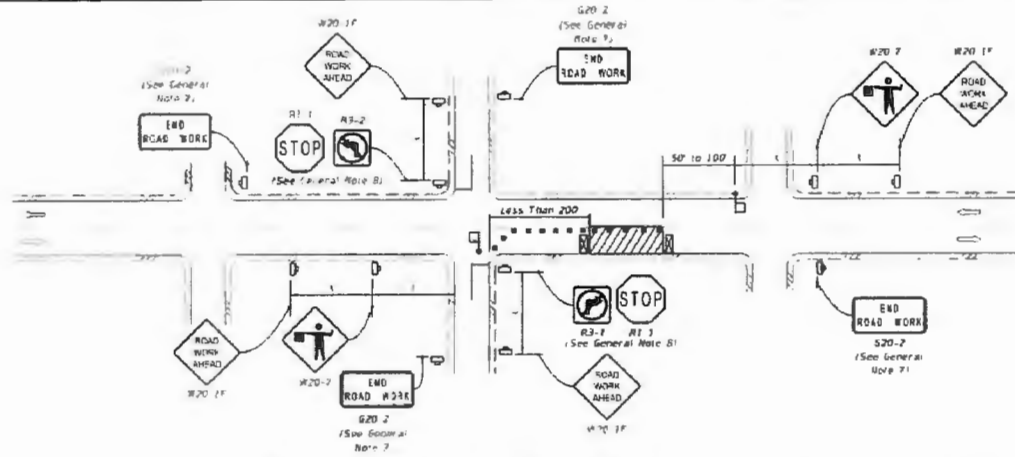

LANE CLOSURE FOR WORK LESS THAN 200' FROM INTERSECTION

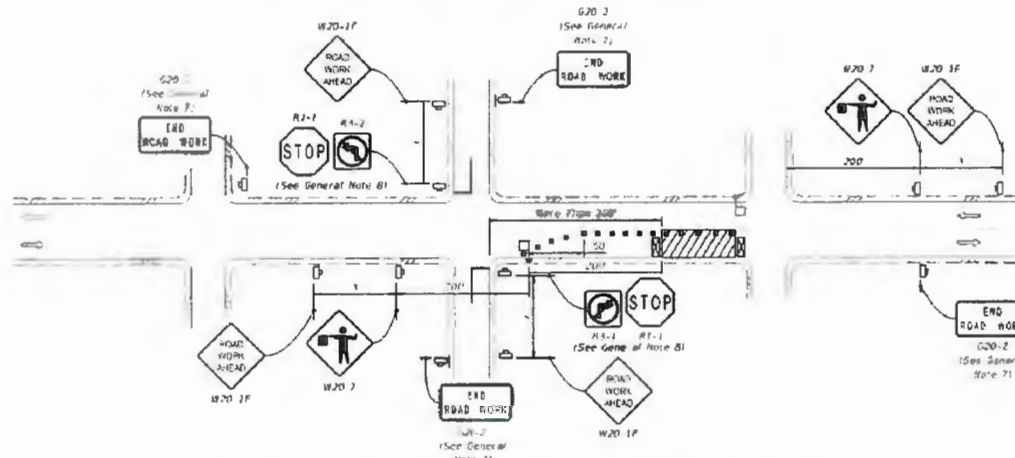

LANE CLOSURE FOR WORK MORE THAN 200' FROM INTERSECTION

LAST REVISION 11/01/22	DESCRIPTION	FY 2025-26 STANDARD PLANS	TWO-LANE, TWO-WAY, INTERSECTION WORK	INDEX 102-604	SHEET 1 of 2
---------------------------	-------------	--------------------------------------	---	------------------	-----------------



DATE	REVISIONS	DESCRIPTIONS	BY
10-16-25		PRELIMINARY DESIGN	

CONSTRUCTION FIRM	
MANAGER	#
PHONE	#

KCI TECHNICAL SERVICES INC.
 150 KELSEY LN.
 TAMPA, FL 33619
 TEL 813-740-2300
 FAX 813-740-0158
 www.kci.com

COLUMBIA COUNTY SCHOOLS PROJECT			
COL_CR_HIGHST_UG_1			
00001927_012			
SHEET NAME	COL_CR_HIGHST_UG_1	CONTACT	R TURNER
TOWN/STATE:	LAKE CITY, FL	COUNTY:	COLUMBIA
REVISION:	0	SHEET:	102-604(1) OF 2

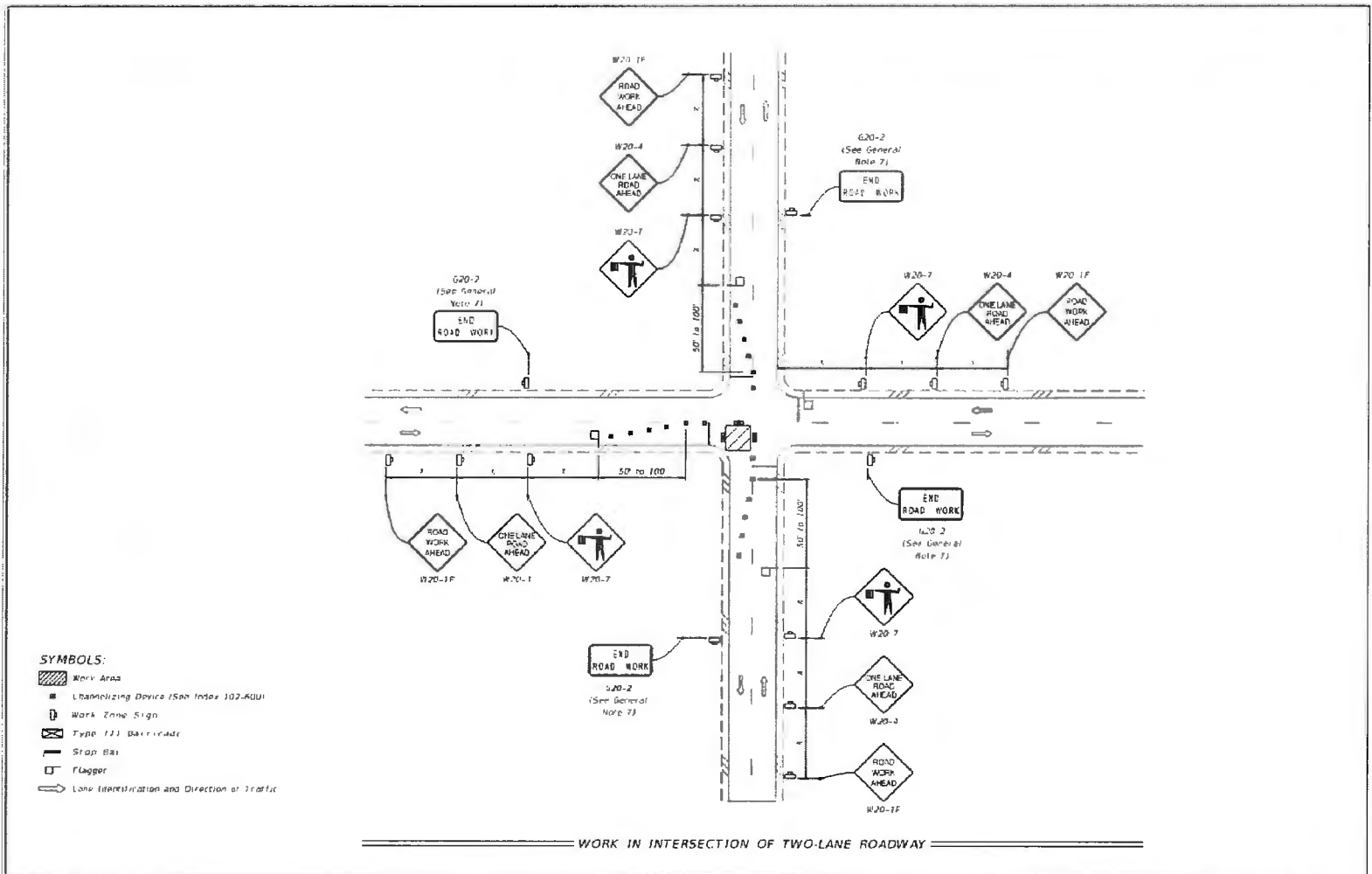

LAST REVISION 11/01/22	DESCRIPTION	FDOT FY 2025-26 STANDARD PLANS	TWO-LANE, TWO-WAY, INTERSECTION WORK	INDEX 102-604	SHEET 2 of 2
---------------------------	-------------	--------------------------------------	--------------------------------------	------------------	-----------------



DATE	DESCRIPTIONS	BY:
10-10-25	PRELIMINARY DESIGN	

CONSTRUCTION FIRM	
MANAGER	#
PHONE	#

KCI
KCI TECHNOLOGIES INC.
150 KELSEY LN.
TAMPA, FL 33619
TEL 813-740-2300
FAX 813-740-0156
www.kci.com



COLUMBIA COUNTY SCHOOLS PROJECT COL_CR_HIGHST_UG_1 00001927_012					
SHEET NAME	COL_CR_HIGHST_UG_1	CONTACT	R TURNER	REVISION	0
TOWN/STATE	LAKE CITY FL	COUNTY	COLUMBIA	SHEET	102-604(2) OF 2

NOTES

- 1 Cover or deactivate pedestrian traffic signal displays controlling raised crosswalks.
- 2 Place pedestrian LCDs across the full width of the closed sidewalk.
- 3 For post mounted signs located near or adjacent to a sidewalk maintain a minimum 7' clearance from the bottom of the sign panel to the surface of the sidewalk.
- 4 "Sidewalk Closure" signs (R9-K2) may be mounted on pedestrian LCDs in accordance with the manufacturer's instructions.
- 5 Omit the Advance Closure LCD if it blocks access to other pedestrian facilities (e.g., transit stops, residences, or business entrances).

SYMBOLS

- Work Area
- Work Zone Sign
- Pedestrian Longitudinal Channelizing Device (LCD)
- Lane Identification and Direction of Traffic

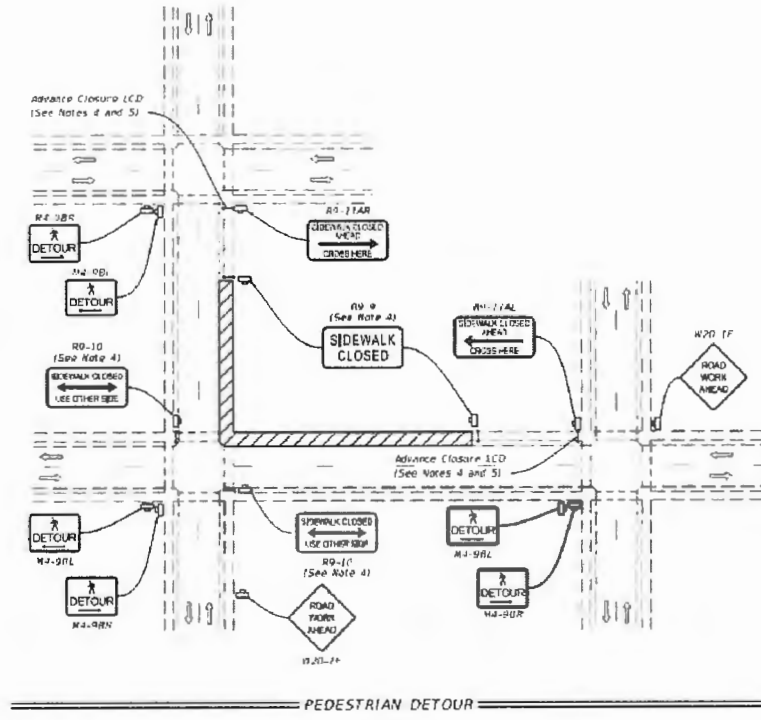

LAST REVISION 11/01/20	DESCRIPTION		FY 2025-26 STANDARD PLANS	SIDEWALK CLOSURE	INDEX 102-660	SHEET 1 of 2
---------------------------	-------------	--	-------------------------------------	-------------------------	------------------	-----------------



REVISIONS		
DATE	DESCRIPTIONS	BY:
10-16-25	PRELIMINARY DESIGN	

CONSTRUCTION FIRM	
MANAGER	#
PHONE	#

KCI TECHNOLOGIES INC.
 150 KELSEY LN.
 TAMPA, FL 33619
 TEL 813-740-2300
 FAX 813-740-0158
 www.kci.com



COLUMBIA COUNTY SCHOOLS PROJECT COL_CR_HIGHST_UG_1 00001927_012			
SHEET NAME	COL_CR_HIGHST_UG_1	CONTACT	R TURNER
TOWN-STATE	LAKE CITY, FL	COUNTY	COLUMBIA
REVISION	0	SHEET	102-660(1) OF 2

NOTES:

- 1 L = Taper Length
- B = Buffer Length
- A = Work Zone Sign Distance
- See notes 102-600 for "L", "B", "A" channelizing device spacing values

- 2 Provide a 5' wide temporary pedestrian way with a maximum cross-slope of 0.8% except when space restrictions warrant a minimum width of 4'. Provide a 5' x 6' paving space for temporary pedestrian ways less than 5' in width at intervals not to exceed 200'
- 3 When temporary pedestrian ways require curb ramps, meet the requirements of notes 522-002. Detectable warnings are not required for curb ramps diverting pedestrian traffic into a closed lane.
- 4 The "Speeding Fines Double When Workers Present" sign (W07-13-06) and "End Road Work" signs (G20-2) along with associated work zone sign distances may be limited when the work operation will be in place for 24 hours or less.
- 5 Pedestrian Diversion Option 2 may only be used when called for in the Plans or as approved by an Engineer.

SYMBOLS:

- Work Area
- Temporary Pedestrian Way
- Channelizing Device (See notes 102-600)
- Pedestrian Longitudinal Channelizing Device (LCD)
- Work Zone Sign
- Arrow Board
- Crash Cushion
- Lane Identification and Direction of Traffic

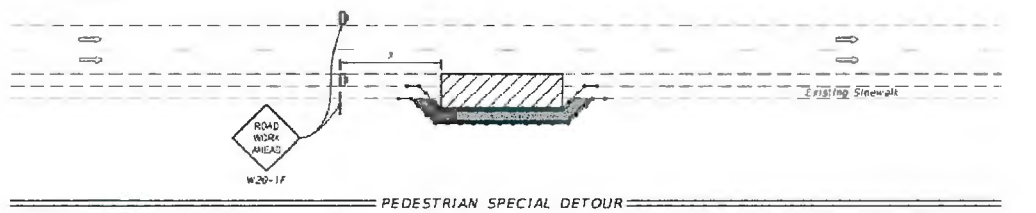
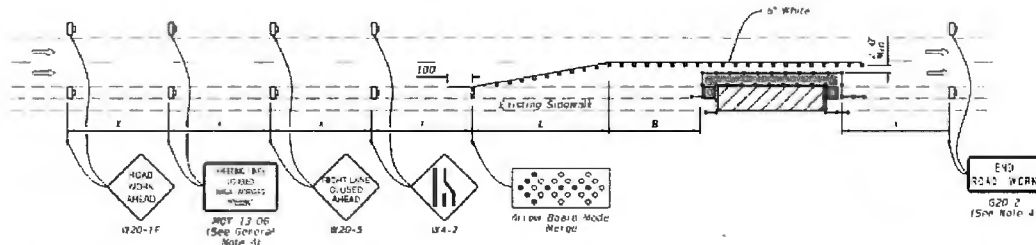
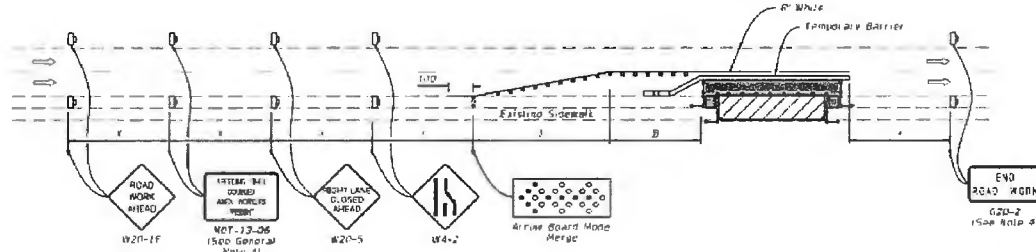

LAST REVISION 11/01/23	DESCRIPTION	FDOT	FY 2025-26 STANDARD PLANS	SIDEWALK CLOSURE	INDEX	SHEET
					102-660	2 of 2



DATE	REVISIONS	DESCRIPTIONS	BY
10/10/25		PRELIMINARY DESIGN	

CONSTRUCTION FIRM	
MANAGER	#
PHONE	#

KCI TECHNOLOGIES INC.
 150 KELSEY LN
 TAMPA, FL 33619
 TEL 813-740-2300
 FAX 813-740-0158
 www.kci.com



COLUMBIA COUNTY SCHOOLS PROJECT COL_CR_HIGHST_UG_1 00001927_012					
SHEET NAME	COL_CR_HIGHST_UG_1	CONTACT	R. TURNER	REVISION	0
TOWN-STATE	LAKE CITY, FL	COUNTY	COLUMBIA	SHEET	102-660(2) OF 2



COLUMBIA COUNTY BOARD OF COUNTY COMMISSIONERS AGENDA ITEM REQUEST FORM

The Board of County Commissioners meets the 1st and 3rd Thursday of each month in the Columbia County School Board Administrative Complex Auditorium, 372 West Duval Street, Lake City, Florida 32055. The first meeting of every month is at 9:30AM while the second meeting of every month takes place at 5:30PM. All agenda items are due in the Board's office one week prior to the meeting date.

Today's Date: 11/13/2025 Meeting Date: 11/20/2025

Department: Public Works

1. Nature and purpose of agenda item:

Utility Permit from WANrack requesting to install a cable on SW High St.

2. Recommended Motion/Action:

Approve

3. Fiscal impact on current budget.

This item has no effect on the current budget.

**COLUMBIA COUNTY BOARD OF COUNTY COMMISSIONERS
UTILITY PERMIT**

Date: _____ Permit No. 250156 County Road SW HIGH ST Section No. _____

Permittee WANRack

Address 4550 W 109th St, Overland Park, KS 66211 Telephone Number 301-752-6692

Requesting permission from Columbia County, Florida, hereinafter called the County, to contract, operate and maintain UNDERGROUND PLACEMENT OF (1) 2" HDPE DUCT WITH 24CT FOC. ALONG SW HIGH ST FOR APPROX. 753'

FROM: US-41 TO: US-441

Submitted for the Utility Owner by: Carrie Namias - KCI Technologies **Carrie Namias**
Digitally signed by Carrie Namias
DN: cn=Carrie Namias, o=KCI
Technologies, ou=email=Carrie Namias
@kci.com, c=US
Date: 2025.10.30.16.11.46.0400
 Typed Name & Title Signature Date

1. Permittee declares that prior to filing this application it has determined the location of all existing utilities, both aerial and underground and the accurate locations are shown on the plans attached hereto and made a part of this application. Proposed work is within corporate limits of Municipality: YES NO (). If YES: LAKE CITY FORT WHITE (). A letter of notification was mailed on 10/30/2025 to the following utility owner: AT & T CITY OF LAKE CITY UTILS, COMCAST CABLE COMMUNICATIONS, FLORIDA POWER & LIGHT-COLUMBIA, FLORIDA UTILITY SERVICES

1LLC SUWANEE VALLEY COUNTRY DALE, FLORIDA UTILITY SERVICES 1LLC SUWANEE VALLEY WOOD GATE

2. The Columbia County Public Works Director shall be notified twenty-four (24) hours prior to starting work and again immediately upon completion of work. The Public Works Director is Kevin Kirby, located at 607 NW Quinten St. Lake City, FL 32025 Telephone Number: 386-758-1019. The PERMITTEE's employee responsible for Maintenance of Traffic is Ryan Hook Telephone Number 240-346-9956 (This name may be provided at the time of the 24 hour notice to starting work.)

3. This PERMITTEE shall commence actual construction in good faith within 60 days after issuance of permit, and shall be completed within 20 days after permitted work has begun. If the beginning date is more than 60 days from date of permit approval, then PERMITTEE must review the permit with the Columbia County Public Works Director to make sure no changes have occurred in the transportation facility that would affect the permitted construction.

4. The construction and maintenance of such utility shall not interfere with the property and rights of a prior PERMITTEE.

5. It is expressly stipulated that this permit is a license for permissive use only and that the placing of utilities upon public property pursuant to this permit shall not operate to create or vest any property right in said holder.

6. Pursuant to Section 337-403(1), Florida Statutes, whenever necessary for the construction, repair, improvement, maintenance, safe and efficient operation, alteration or relocation of all, or any portion of said transportation facility as determined by the Columbia County Public Works Director and/or County Engineer, any or all utilities and appurtenances authorized hereunder, shall be immediately removed from said transportation facility or reset or

relocated thereon as required by the Columbia County Public Works Director and/or County Engineer and at the expense of the PERMITTEE.

7. In case of non-compliance with the County's requirements in effect as of the approval date of this permit, this permit void and the facility will have to be brought into compliance or removed from the right of way at no cost to the County.

8. It is understood and agreed that the rights and privileges herein set out are granted only to the extent of the County's right, title and interest in the land to be entered upon and used by the PERMITTEE, and the PERMITTEE will, at all times, and to the extent permitted by law, assume all risk of and indemnify, defend, and save harmless Columbia County, Florida from any and all loss, damage, cost or expense arising in any manner on account of the exercise or attempted exercise by said PERMITTEE of the aforesaid right and privileges.

9. During construction, all safety regulations of the County shall be observed and the PERMITTEE must take measures, including pacing and the display of safety devices that may be necessary in order to safely conduct the public through the project area in accordance with the Federal Manual on Uniform Traffic Control Devices, as amended for highways.

10. Should the PERMITTEE be desirous of keeping its utilities in place and out of service, the PERMITTEE, by execution of this permit acknowledges its present and continuing ownership of its utilities located between US-41 _____ and US-441 _____ within the County's right of way as set forth above. PERMITTEE, as its sole expense, shall promptly remove said out of service utilities whenever Columbia County Public Works Director and/or County Engineer determines said removal is in the public interest.

11. Special instructions: Minimum cover of thirty inches (30") will be required at all locations. Columbia County will not be financially responsible for any damage to facilities with less than thirty inches (30") cover. Cables shall not be located within driveway ditches.

12. Additional Stipulations: _____

* Contact Ken Sweet (386) 466-8037 before start of work onsite.

It is understood and agreed that commencement by the PERMITTEE is acknowledgment and acceptance of the binding nature of these specialist instructions.

Submitted By: WANRack, LLC
Permittee

Signature and Title

Caulan Brooks,
GIS Design Team Manager

Place Corporate Seal

Attested

Cole Campbell,
Designer

Utilities Permit
Page three
Revised: 8/17/00

Recommended for Approval:

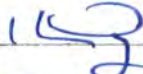
Signature: 
Title: Asst. County Manager
Date: 11/20/05

Approval by Board of County Commissioners, Columbia County, Florida:

YES () NO ()

Date Approved: 11/20/2005

Chairman's Signature: 