

# COLUMBIA COUNTY Property Appraiser

## Parcel 01-4S-15-00320-000

### Owners

HERNDON VICTOR C  
HERNDON AMANDA E  
269 SW MELODY GLN  
LAKE CITY, FL 32024

### Parcel Summary

Location	267 SW MELODY GLN
Use Code	0100: SINGLE FAMILY
Tax District	3: COUNTY
Acreage	5.0000
Section	01
Township	4S
Range	15
Subdivision	DIST 3
Exemptions	01: HOMESTEAD (196.031a&b) (100%)

### Additional Site Addresses

269 SW MELODY GLN

### Legal Description

W1/2 OF S1/2 OF S1/2 OF NE1/4 OF NW1/4.

676-655, 725-523, 755-2119,2122, 845-533,  
899-737, WD 1373-1598 THRU 1601

### Working Values

	2026
Total Building	\$226,876



	2026
Total Extra Features	\$2,200
Total Market Land	\$55,000
Total Ag Land	\$0
Total Market	\$284,076
Total Assessed	\$199,876
Total Exempt	\$55,722
Total Taxable	\$144,154
SOH Diff	\$84,200

## Value History

	2025	2024	2023	2022	2021	2020	2019
Total Building	\$230,927	\$220,289	\$204,883	\$180,140	\$168,364	\$142,236	\$133,238
Total Extra Features	\$2,200	\$2,200	\$2,200	\$2,200	\$2,200	\$2,200	\$2,200
Total Market Land	\$55,000	\$40,000	\$40,000	\$35,000	\$31,000	\$30,934	\$30,934
Total Ag Land	\$0	\$0	\$0	\$0	\$0	\$0	\$0
Total Market	\$288,127	\$262,489	\$247,083	\$217,340	\$201,564	\$175,370	\$166,372
Total Assessed	\$194,054	\$188,585	\$183,092	\$177,759	\$172,582	\$170,199	\$166,372
Total Exempt	\$55,722	\$55,000	\$50,000	\$50,000	\$50,000	\$50,000	\$50,000
Total Taxable	\$138,332	\$133,585	\$133,092	\$127,759	\$122,582	\$120,199	\$116,372
SOH Diff	\$94,073	\$73,904	\$63,991	\$39,581	\$28,982	\$5,171	\$0

## Document/Transfer/Sales History

Instrument / Official Record	Date	Q/U	Reason	Type	V/I	Sale Price	Ownership
<u>WD</u> 1373/1601	2018-11-30	<u>U</u>	<u>16</u>	WARRANTY DEED	Improved	\$27,300	Grantor: JOSHUA BISQUE Grantee: VICTOR C HERNDON & AMANDA E HERNDON (H/W)
<u>WD</u> 1373/1600	2018-11-30	<u>U</u>	<u>16</u>	WARRANTY DEED	Improved	\$27,300	Grantor: JOSEPH BISQUE Grantee: VICTOR C HERNDON & AMANDA E HERNDON (H/W)
<u>WD</u> 1373/1599	2018-11-30	<u>U</u>	<u>16</u>	WARRANTY DEED	Improved	\$27,300	Grantor: TIMOTHY BISQUE Grantee: VICTOR C HERNDON & AMANDA E HERNDON (H/W)

Instrument / Official Record	Date	Q/U	Reason	Type	V/I	Sale Price	Ownership
<u>WD</u> 1373/1598	2018-11-30	<u>U</u>	<u>16</u>	WARRANTY DEED	Improved	\$81,800	Grantor: GERALD BISQUE Grantee: VICTOR C HERNDON & AMANDA E HERNDON (H/W)
<u>AG</u> 0725/0523	1990-07-06	<u>Q</u>	<u>01</u>	AGREEMENT FOR DEED	Vacant	\$21,000	Grantor: JACKIE TAYLOR Grantee: GERALD BISQUE

## Buildings

### Building # 2, Section # 1, 139942, SFR

Type	Model	Heated Area	Gross Area	Repl Cost New	YrBlt	Year Eff	Other % Dpr	Normal % Dpr	% Cond	Value
<u>0100</u>	<u>01</u>	2576	3072	\$324,108	2001	2001	0.00%	30.00%	70.00%	\$226,876

## Structural Elements

Type	Description	Code	Details
EW	Exterior Wall	31	VINYL SID
RS	Roof Structure	03	GABLE/HIP
RC	Roof Cover	12	MODULAR MT
IW	Interior Wall	05	DRYWALL
IF	Interior Flooring	14	CARPET
IF	Interior Flooring	15	HARDTILE
AC	Air Conditioning	03	CENTRAL
HT	Heating Type	04	AIR DUCTED
BDR	Bedrooms	4.00	
BTH	Bathrooms	2.50	
FR	Frame	02	WOOD FRAME
STR	Stories	2.	2.
AR	Architectual Type	05	CONV
COND	Condition Adjustment	03	03
KTCH	Kitchen Adjustment	01	01

## Sub Areas

Type	Gross Area	Percent of Base	Adjusted Area
<u>BAS</u>	144	100%	144
<u>BAS</u>	1,120	100%	1,120
<u>FUS</u>	1,120	100%	1,120
<u>PTO</u>	304	5%	15
<u>SFB</u>	192	80%	154
<u>UOP</u>	192	20%	38

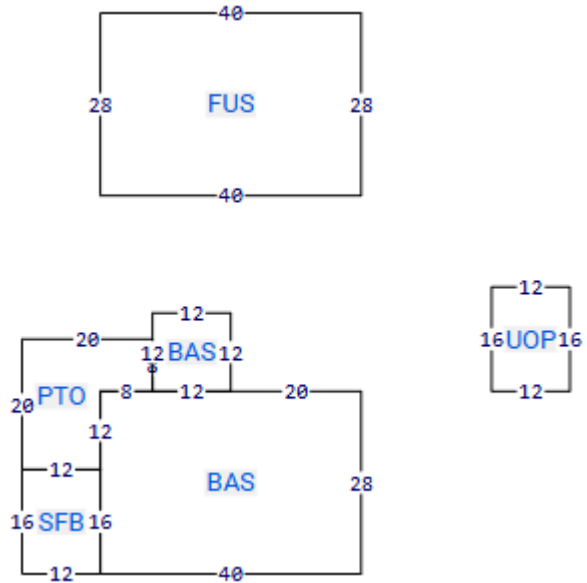

## Extra Features

Code	Description	Length	Width	Units	Unit Price	AYB	% Good Condition	Final Value
0294	SHED WOOD/VINYL	8	12	1.00	\$0.00	1994	100%	\$500
0040	BARN,POLE	24	48	1.00	\$0.00	1994	100%	\$1,000
0255	MBL HOME STORAGE			1.00	\$0.00	2016	100%	\$500
0081	DECKING WITH RAILS			1.00	\$0.00	2016	100%	\$200

## Land Lines

Code	Description	Zone	Front	Depth	Units	Rate/Unit	Acreage	Total Adj	Value
0100	SFR	<u>A-1</u>	.00	.00	5.00	\$11,000.00/ <u>AC</u>	5.00	1.00	\$55,000

## Personal Property

None

## Permits

Date	Permit	Type	Status	Description
	13776	SFR	COMPLETED	SFR

## TRIM Notices

2025  
2024  
2023

## Disclaimer

All parcel data on this page is for use by the Columbia County Assessor for assessment purposes only. The summary data on this page may not be a complete representation of the parcel or of the improvements thereon. Building information, including unit counts and number of permitted units, should be verified with the appropriate building and planning agencies. Zoning information should be verified with the appropriate planning agency. All parcels are reappraised each year. This is a true and accurate copy of the records of the Columbia County Assessor's Office as of October 02, 2025.

---

Copyright © 2022 Columbia County. All rights reserved.

---