

**COLUMBIA COUNTY, FLORIDA
BOARD OF COUNTY COMMISSIONERS
INVITATION TO BID 2026-I
FIRE STATION #51 GENERATOR**

The Board of County Commissioners (County) will receive sealed proposals in the office of Commissioners, 135 NE Hernando Avenue, Suite 203, Lake City, FL 32055, until 2:00 PM local time on April 23, 2026 for the following:

FIRE STATION #51 GENERATOR

To be eligible for consideration, all proposers must be registered in the State of Florida to practice their profession at the time of proposal. Proposers without a complete proposal described will be considered improper. The solicitation information is available online only at: <http://www.columbiacountyfla.com/PurchasingBids.asp>

Submissions will be publicly opened in the Commissioner's Office at 2:00 PM, April 23, 2026, or as soon thereafter as practical. Proposers are responsible for the delivery of submissions. Submissions may be withdrawn at any time prior to the opening. Late bids will not be accepted. Bids delivered in any other format other than specified in this solicitation will not be accepted. Questions regarding this solicitation must be received via email to Erica Jones, Purchasing Officer, at ejones@columbiacountyfla.com no later than April 16, 2026 at 5:00 PM local time.

All Proposers are advised that under Chapter 119, Florida Statutes, all responses are deemed a public record and open to the public as provided for in said statute.

GENERAL INSTRUCTIONS TO BIDDERS

These instructions will bind bidders and conditions herein set forth, except as specifically qualified in special bid and contract terms issued with any individual bid.

1. The following criteria are used in determining low responsible bidder:
 - A. The ability, capacity and skill of bidder to perform required service.
 - B. Whether the bidder can perform service promptly or within specified time.
 - C. The determined character, integrity, reputation, judgment, experience and efficiency of bidder.
 - D. The performance of previous contracts with Columbia County or entities similar to Columbia County.
 - E. The suitability of equipment or material for County use.
 - F. The ability of bidder to provide future maintenance.
2. Payment Terms are net thirty (30) unless otherwise specified. Favorable terms, discounts, may be offered and will be considered in determining low bids if they are deemed by Purchasing Department to be advantageous to the County.
3. All bids should be tabulated, totaled and checked for accuracy. Where applicable, the provided unit price will prevail in case of discrepancies or other errors.
4. All requested information shall be included in the envelope. All desired information must be included for your bid to receive full consideration.
5. If anything on the bid request is not clear, you should contact the Purchasing Director immediately.
6. A bidders list is available at the Purchasing Office.
7. Quote all prices F.O.B. our warehouse or as specified in bid documents.
8. Each proposal shall be clearly marked on the outside of the envelope including Fed Ex, UPS or other delivery service envelopes, as a sealed bid. The name of the item being bid shall be shown on the outside in full.
9. The County shall not be liable for any bid opened prematurely if that bid was not sealed in a properly marked envelope.
10. If only one (1) bid is received, the bid may be rejected and re-advertised or excepted if determined to be in the counties best interest.
11. Bids received late will not be accepted. It is the bidder's sole responsibility to ensure proposals are timely delivered and received before the deadline.
12. Telephone and facsimile bids will not be accepted under any circumstances. Should a timely delivered bid be misplaced by the County but later found before ranking occurs, the

bid will be considered. A bidder may request a receipt showing the day and time a bid envelope is delivered to the appropriate office of the County.

13. Bids requiring bid bonds will not be accepted if bond is not enclosed. Cash or certified check will be accepted in lieu of bond except on construction projects with a project budget exceeding \$40,000.
14. Upon request of the Purchasing Office or County Manager, a bidder must provide proof that the bidder has the requisite organization, capital, plant, stock, ability, and experience to perform the contract contemplated by the Request for Proposals/Qualifications or Invitation to Bid.
15. Any alterations, erasures, additions, or omissions of required information or any changes to specifications or bidding schedule are done at the risk of the bidder. Any bid will be rejected that has a substantial variation, that is; a variation that affects price, quantity, and quality or delivery date (when delivery is required by a specific time).
16. When requested, samples will be furnished to the County free of expense, properly marked for identification and accompanied by a list where there is more than one (1) sample. The County reserves the right to mutilate or destroy any sample submitted whenever it may be to the best interest of the County to do so for the purpose of testing.
17. The County will reject any material, supplies or equipment that did not meet the specifications, even though the bidder lists the trade names or names of such material on the bid or price quotation form.
18. The unauthorized use of patented articles is done entirely at the risk of the successful bidder.
19. The ESTIMATED QUANTITY given in the specifications or advertisements is for the purpose of bidding only. The County may purchase more or less than the estimated quantity and the vendor must not assume that such estimated quantity is part of the contract.
20. Only the latest model equipment as evidenced by the manufacture's current published literature will be considered. Obsolete models of equipment not in production will not be acceptable. The equipment shall be composed of new parts and materials. Any unit containing used parts or having seen any service other than the necessary tests will be rejected. In addition to the equipment specifically called for in the specification, all equipment catalogued by the manufacturer as standard or required by the State of Florida shall be furnished with the equipment. Where required by the State of Florida Motor Vehicle Code, vehicles shall be inspected and bear the latest inspection sticker of the Florida Department of Revenue.
21. The successful bidder on motor vehicle equipment shall be required to furnish with delivery of vehicle, certificate of origin and any other appropriate documentation as required by the Florida Motor Vehicle Department.
22. Prospective bidders are required to examine the location of the proposed work or delivery

and determine, in their own way, the difficulties, which are likely to be encountered in the prosecution of the same.

23. All materials, equipment and supplies shall be subject to rigid inspection, under the immediate supervision of the Purchasing Department, its designee and /or the department to which they are delivered. If defective material, equipment, or supplies are discovered, the contractor, upon being instructed by the Purchasing Department or designee, shall remove, or make good such material, equipment, or supplies without extra compensation. It is expressly understood and agreed that the inspection of materials by the County will in no way lessen the responsibility of the Contractor release him from his obligation to perform and deliver to the County Sound and satisfactory materials, equipment, or supplies. The Contractor agrees to pay the costs of all tests upon defective material, equipment, or supplies or allow the costs to be deducted from any monies due him from the County.
24. Unless otherwise specified by the Purchasing Department all materials, supplies, or equipment quoted herein must be delivered within thirty (30) days from the day of notification or exceptions noted on bid sheets.
25. A contract will not be awarded to any corporation, firm, or individual who is, from any cause, in arrears to the County or who has failed in former contracts with the County to perform work satisfactorily, either to the character of the work, the fulfillment or guarantee, or the time consumed in completing the work.
26. Reasonable grounds for supposing that any bidder is interested in more than one proposal for the same item will be considered sufficient cause for rejection of all proposals in which he is interested.
27. Submitting a proposal when the bidder intends to sublet the contract may be a cause for rejection of bids or cancellation of the contract by the County Manager.
28. Unless otherwise specified, the County reserves the right to award each items separately or on a lump sum basis whichever is in the best interest of the County.
29. Respondents to this solicitation or persons acting on their behalf may not contact, between the release of the solicitation and the end of the 72-hour period following the agency posting the notice of intended award, excluding Saturdays, Sundays, and state holidays, any employee or officer of the executive or legislative branch concerning any aspect of this solicitation, except in writing to the procurement officer or as provided in the solicitation documents. Violation of this provision may be grounds for rejecting a response.
30. The County reserves the right to reject any quotations or specifications and the right to waive minor discrepancies as to all bidders equally, when such rejection or waiver is deemed to be in the best interest of the County. For unit priced items, the County may elect to purchase part, all, or none of the materials, supplies, or equipment specified in a bid.
31. The bidder or the bidder's authorized representative or agent must sign the bid in the space provided. Unsigned bids will be rejected. Signature must be "wet" signatures in ink. Typewritten or printed signatures will not be accepted.

32. Any bidder may withdraw his/her bid at any time before the time set for the opening of the bids.
33. It is mutually understood and agreed that if at any time the Purchasing Department or designee shall be of the opinion that the contract or any part thereof is unnecessarily delayed or that the rate of progress or delivery is unsatisfactory, or that the contractor is willfully violating any of the conditions or covenants of the agreement, or executing the same in bad faith, the Purchasing Department or his/her designee shall have the power to notify the contractor of the nature of the complaint. Notification shall constitute delivery of notice, or letter to address given in the proposal. If after three (3) working days of notification the conditions are not corrected to the satisfaction of the Purchasing Officer, he shall have the power to take whatever action necessary to complete the work or delivery and the expense shall be deducted from any paid by the County out of such monies as may become due to the said contractor. In case such expense shall exceed the last said sum, then and in that event, the bondsman or the contractor, his/her executors, administrators, successors, or assigns, shall pay the amounts of such excess to the County on notice made by the Purchasing Department or his/her designee of the excess due.
34. If the bidder proposes to furnish any item of foreign make or product, he shall write "foreign" together with the name of the originating country opposite such item on a proposal.
35. Any complaint from bidders relative to the invitation to bid or attached specifications shall be made prior to the time of opening bids; otherwise, the bidder waives any such complaint.
36. Contracts may be cancelled by the County with or without cause on thirty- (30) days advance written notice.
37. All contractors submitting bids for road projects in excess of \$250,000 must be pre-qualified with the Florida Department of Transportation and shall provide proof of such qualification.
38. Any bidder affected adversely by an intended decision with respect to the award of any bid, shall file with the Purchasing Department for Columbia County, a written notice of intent to file a protest not later than seventy-two (72) hours (excluding Saturdays, Sundays and legal holidays), after the posting of the bid tabulation. Protest procedures may be obtained in the Purchasing Department.
39. A person or affiliate who has been placed on the convicted vendor's list following a conviction for a public entity crime may not submit a bid on a contract to provide any goods or services to Columbia County, may not submit a bid on a contract with Columbia County for the construction or repair of a public building or public work, may not submit bids on leases of real property to Columbia County, may not be awarded or perform work as a contractor, supplier, subcontractor, or consultant under a contract with Columbia County, and may not transact business with Columbia County for a period of 36 months from the date of being placed on the convicted vendor list.
40. Vendor/Contractor shall utilize the U.S. Department of Homeland Security's E-Verify

system, in accordance with the terms governing use of the system, to confirm the employment eligibility of;

- A. All persons employed by the Vendor/Contractor during the term of the Contract to perform employment duties within Florida; and
- B. All persons, including subcontractors, assigned by the Vendor/Contractor to perform work pursuant to the contract with the County.

41. Contractor shall register on line at <https://www.columbiacountyfla.com/PurchasingBids.asp> for this specific project. All addendums are delivered via email through this website, and it is the contractor's responsibility to ensure all addendums are used in the bid submittal.

PROJECT INFORMATION

The Columbia County Board of Commissioners is seeking quotes for an 80KW Generac to include materials and labor.

A Non-Mandatory Pre-Bid Conference will be held at Fire Station #51 located at 1579 NW Lake Jeffery Road, Lake City, FL 32055 on April 6, 2026 at 10:00 AM. Late arrivals will not be permitted. Any questions about the Pre-Bid please contact Donald Dupree at 386) 867-0953.

SCOPE OF WORK

The Contractor shall provide a Lump Sum quote for the furnishing, delivery, installation, and commissioning of one (1) 80 kW Generac natural gas-powered generator, including all materials, labor, equipment, and services necessary for a complete and operational system. Work shall include connection to the existing Automatic Transfer Switch (ATS) and the existing natural gas meter.

1. Installation and Testing Requirements

2. Contractor shall perform full installation of the generator, including all wiring, piping, interconnections, and mounting required for proper operation.
3. Start-up and testing shall include a 4-hour load bank test, conducted Monday–Friday, 8:00 AM–5:00 PM, excluding holidays.
4. The generator installation, testing preparations, and all fuel/gas connections must be fully complete prior to scheduling start-up.
5. If, at the time of start-up, the installation is incomplete or natural gas is not available, the Contractor must return and complete the start-up at no additional cost to the County.
6. All field start-up and testing must be performed by a Factory-Certified Technician approved by the generator manufacturer.
7. Load bank testing must utilize a resistive type load bank only.

2. Schedule Requirements

Contractor shall complete installation and commissioning within 30 days after materials are received on site.

Contractor must provide proof of lead time for all equipment and materials as part of the bid.

3. Responsibility of County

1. The County will provide and complete the concrete generator pad prior to Contractor installation.
2. The Contractor shall be responsible for verifying pad dimensions and suitability prior to installation.

5. Additional Documentation

- **Exhibit A:** Generac Specifications and Transfer Switches (Provided by County)
Contractor shall review and comply with all specifications, dimensions, and site details included in Exhibit A.

BID FORM
ITB No. 2026-I
Project Title: Fire Station #51 Generator

Bidder Name: _____

BASE BID – LUMP SUM

The undersigned hereby propose to furnish all materials, labor and supervision for the construction of the subject project including conformance with the construction requirements and specifications.

Total Lump Sum Bid (Complete Project):

\$ _____

Written Lump Sum Bid:

\$ _____

(Amount shall include generator, materials, labor, installation, testing, permits (if applicable), delivery, overhead, profit, and all other incidentals necessary for a complete and operational system.)

ADDENDA ACKNOWLEDGMENT

Bidder acknowledges receipt of the following addenda (check all that apply):

Addendum No. 1 Date Published: _____

Addendum No. 2 Date Published: _____

Addendum No. 3 Date Published: _____

BIDDER INFORMATION

Company Name: _____

Mailing Address: _____

City/State/ZIP: _____

Phone: _____ Email: _____

Authorized Representative (print): _____

Title: _____

Signature: _____ Date: _____

Exhibit A

Quantity 1 - Generac Industrial gaseous 9.0L V-8 engine-driven generator, consisting of the following features and accessories:

- Stationary Emergency-Standby rated
- 80 kW Rating, wired for 120/240 VAC single phase, 60 Hz
- Permanent Magnet Excitation
- Natural Gas fuel system
- Level 2 Acoustic Enclosure, Aluminum
 - Industrial Grey Baked-On Powder Coat Finish
 - 150 MPH Wind Load Certified
 - AC/DC Enclosure Interior LED Lighting Kit
 - 8 Position 1PH Load Center
- UL2200
- EPA Certified
- H-100 Control Panel
 - Meets NFPA 99 and 110 requirements
 - Temp Range -40 to 70 degrees C
 - Digital Microprocessor:
 - Two 4-line x 20 displays, full system status
 - 3 Phase sensing, +/-0.25% digital voltage regulation
 - RS232, RS485 and Canbus remote ports
 - Waterproof connections
 - All engine sensors are 4-20ma for minimal interference
 - Programmable I/O
 - Built-in PLC for special applications
 - Engine function monitoring and control:
 - Full range standby operation; programmable auto crank, Emergency Stop, Auto-Off-Manual switch
 - Isochronous Governor, +/-0.25% frequency regulation
 - Full system status on all AC output and engine function parameters
 - Service reminders, trending, fault history (alarm log)
 - I2T function for full generator protection
 - Selectable low-speed exercise
 - 2-wire start controls for any 2-wire transfer switch
- 21 Light Annunciator - Surface
- Remote Emergency Stop Switch, break-glass, shipped loose
- Battery Heating Pad
- 90 AH, 700 CCA Group 27F Battery, with rack, installed
- Air Filter Restriction Ind
- Battery Charger, 10 Amp, NFPA 110 compliant, installed
- Coolant Heater, 1500W, 120VAC
- Std set of 3 Manuals
- 120V GFCI and 240V Outlet
- Alternator Strip Heater
- Alternator Tropical Coating
- Engine Run Relay
- Flex Fuel Line
- Flush Mount Annunciator Kit
- MLCB, 100% rated, LSI Electronic Trip
 - 400 Amp
 - Shunt trip and Auxiliary Contacts
- Standard 2-Year Limited Warranty

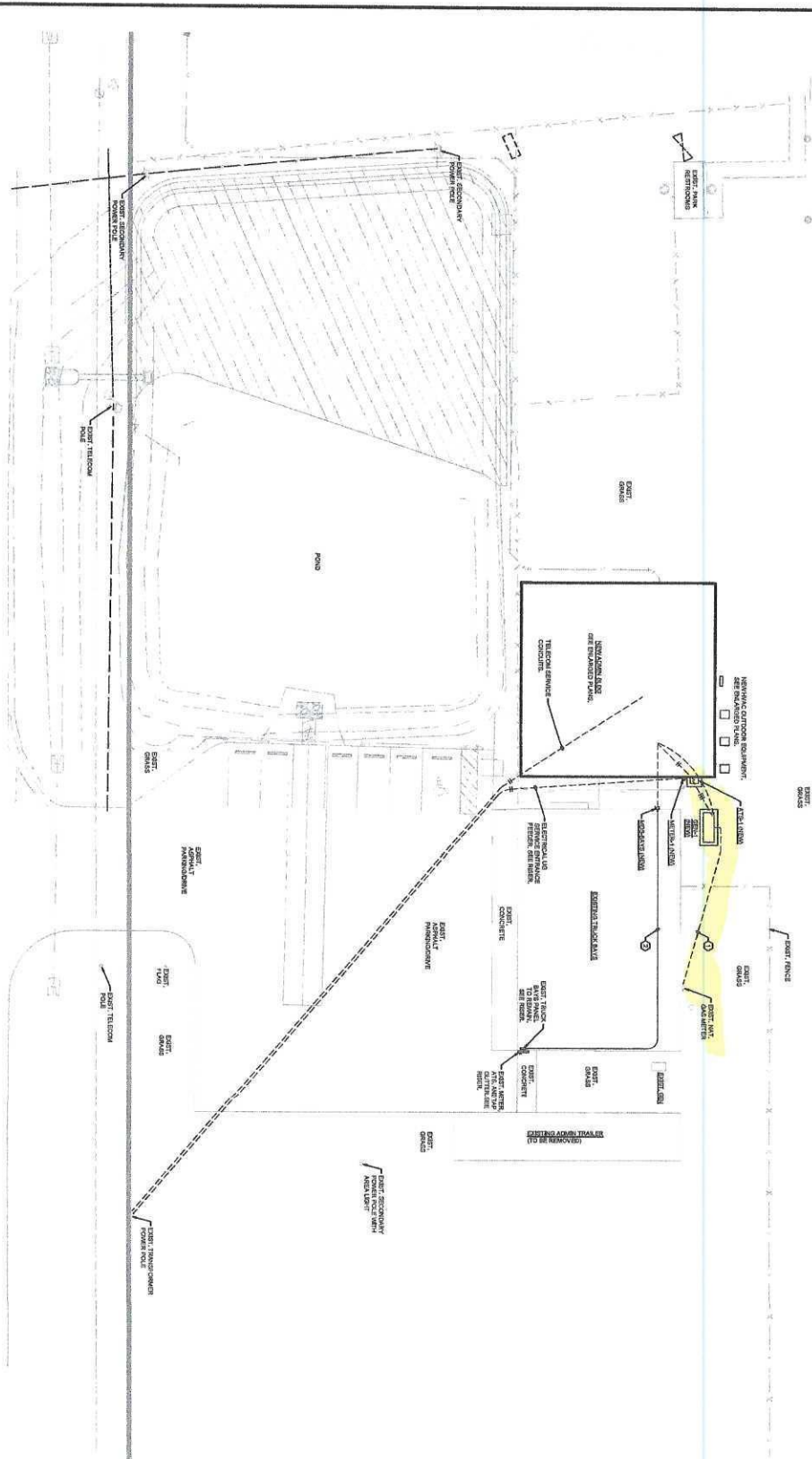
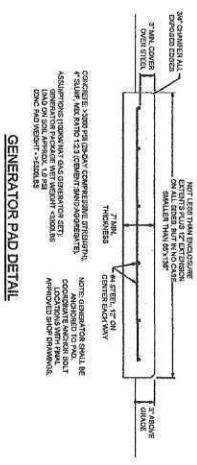
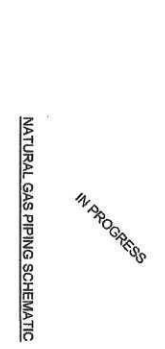
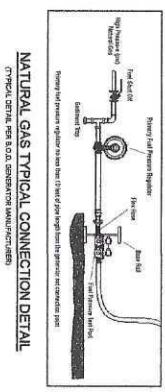

SHEET NOTES

- 1. NOTE: ALL DIMENSIONS ARE TO FACE UNLESS OTHERWISE NOTED.
- 2. ALL DIMENSIONS ARE TO FACE UNLESS OTHERWISE NOTED.
- 3. ALL DIMENSIONS ARE TO FACE UNLESS OTHERWISE NOTED.
- 4. ALL DIMENSIONS ARE TO FACE UNLESS OTHERWISE NOTED.

SHEET KEYNOTES

- 1. NATURAL GAS PIPING: SEE UTILITY DRAWINGS FOR CONNECTION TO NATURAL GAS SERVICE.
- 2. NATURAL GAS VALVE: SEE UTILITY DRAWINGS FOR CONNECTION TO NATURAL GAS SERVICE.
- 3. NATURAL GAS METER: SEE UTILITY DRAWINGS FOR CONNECTION TO NATURAL GAS SERVICE.
- 4. NATURAL GAS SERVICE: SEE UTILITY DRAWINGS FOR CONNECTION TO NATURAL GAS SERVICE.

ENTIRE SHEET ADDED

COBURN AND ASSOCIATES
 ARCHITECTURE & INTERIORS
 1579 NW LAKE JEFFERY ROAD
 LAKE CITY, FLORIDA 32829
 (407) 403-1111
 www.coburnandassociates.com

SITE PLAN

DATE: 09/17/2024
 2338
 E101

CONSTRUCTION DOCUMENTS

NEW FIRE DEPARTMENT ADMINISTRATION BUILDING
 1579 NW LAKE JEFFERY ROAD
 LAKE CITY, FLORIDA
 CCBC PROJECT NUMBER

PRELIMINARY DESIGN REVISION FOR OWNER REVIEW NOT APPROVED FOR CONSTRUCTION

ARCHITECTURE & INTERIORS
 ARCHITECTS

1579 NW LAKE JEFFERY ROAD
 LAKE CITY, FLORIDA 32829
 (407) 403-1111
 www.coburnandassociates.com

INTERIOR LIGHTING COMPLIANCE

SPACE	AREA (SQ. FT.)	MIN. FOOT-CANDLES	MIN. FOOT-CANDLES PER SQ. FT.	MIN. FOOT-CANDLES PER SQ. FT. (AVG.)	MIN. FOOT-CANDLES PER SQ. FT. (PEAK)
RECEPTION	1,200	10	10	10	10
OFFICE	2,500	10	10	10	10
CONFERENCE	1,500	10	10	10	10
TRAINING	3,000	10	10	10	10
RESTROOM	500	10	10	10	10
STORAGE	1,000	10	10	10	10
MEETING	1,000	10	10	10	10
RECEPTION	1,200	10	10	10	10
OFFICE	2,500	10	10	10	10
CONFERENCE	1,500	10	10	10	10
TRAINING	3,000	10	10	10	10
RESTROOM	500	10	10	10	10
STORAGE	1,000	10	10	10	10
MEETING	1,000	10	10	10	10

LIGHTING FIXTURE SCHEDULE

SYMBOL	QUANTITY	DESCRIPTION
1	10	2' x 4' RECESSED LED PANEL LIGHT, 40W, 4000K, DIMMABLE
2	5	4' x 4' RECESSED LED PANEL LIGHT, 80W, 4000K, DIMMABLE
3	10	2' x 2' RECESSED LED PANEL LIGHT, 20W, 4000K, DIMMABLE
4	10	2' x 2' RECESSED LED PANEL LIGHT, 20W, 4000K, DIMMABLE
5	10	2' x 2' RECESSED LED PANEL LIGHT, 20W, 4000K, DIMMABLE
6	10	2' x 2' RECESSED LED PANEL LIGHT, 20W, 4000K, DIMMABLE
7	10	2' x 2' RECESSED LED PANEL LIGHT, 20W, 4000K, DIMMABLE
8	10	2' x 2' RECESSED LED PANEL LIGHT, 20W, 4000K, DIMMABLE
9	10	2' x 2' RECESSED LED PANEL LIGHT, 20W, 4000K, DIMMABLE
10	10	2' x 2' RECESSED LED PANEL LIGHT, 20W, 4000K, DIMMABLE
11	10	2' x 2' RECESSED LED PANEL LIGHT, 20W, 4000K, DIMMABLE
12	10	2' x 2' RECESSED LED PANEL LIGHT, 20W, 4000K, DIMMABLE
13	10	2' x 2' RECESSED LED PANEL LIGHT, 20W, 4000K, DIMMABLE
14	10	2' x 2' RECESSED LED PANEL LIGHT, 20W, 4000K, DIMMABLE
15	10	2' x 2' RECESSED LED PANEL LIGHT, 20W, 4000K, DIMMABLE
16	10	2' x 2' RECESSED LED PANEL LIGHT, 20W, 4000K, DIMMABLE
17	10	2' x 2' RECESSED LED PANEL LIGHT, 20W, 4000K, DIMMABLE
18	10	2' x 2' RECESSED LED PANEL LIGHT, 20W, 4000K, DIMMABLE
19	10	2' x 2' RECESSED LED PANEL LIGHT, 20W, 4000K, DIMMABLE
20	10	2' x 2' RECESSED LED PANEL LIGHT, 20W, 4000K, DIMMABLE
21	10	2' x 2' RECESSED LED PANEL LIGHT, 20W, 4000K, DIMMABLE
22	10	2' x 2' RECESSED LED PANEL LIGHT, 20W, 4000K, DIMMABLE
23	10	2' x 2' RECESSED LED PANEL LIGHT, 20W, 4000K, DIMMABLE
24	10	2' x 2' RECESSED LED PANEL LIGHT, 20W, 4000K, DIMMABLE
25	10	2' x 2' RECESSED LED PANEL LIGHT, 20W, 4000K, DIMMABLE
26	10	2' x 2' RECESSED LED PANEL LIGHT, 20W, 4000K, DIMMABLE
27	10	2' x 2' RECESSED LED PANEL LIGHT, 20W, 4000K, DIMMABLE
28	10	2' x 2' RECESSED LED PANEL LIGHT, 20W, 4000K, DIMMABLE
29	10	2' x 2' RECESSED LED PANEL LIGHT, 20W, 4000K, DIMMABLE
30	10	2' x 2' RECESSED LED PANEL LIGHT, 20W, 4000K, DIMMABLE
31	10	2' x 2' RECESSED LED PANEL LIGHT, 20W, 4000K, DIMMABLE
32	10	2' x 2' RECESSED LED PANEL LIGHT, 20W, 4000K, DIMMABLE
33	10	2' x 2' RECESSED LED PANEL LIGHT, 20W, 4000K, DIMMABLE
34	10	2' x 2' RECESSED LED PANEL LIGHT, 20W, 4000K, DIMMABLE
35	10	2' x 2' RECESSED LED PANEL LIGHT, 20W, 4000K, DIMMABLE
36	10	2' x 2' RECESSED LED PANEL LIGHT, 20W, 4000K, DIMMABLE
37	10	2' x 2' RECESSED LED PANEL LIGHT, 20W, 4000K, DIMMABLE
38	10	2' x 2' RECESSED LED PANEL LIGHT, 20W, 4000K, DIMMABLE
39	10	2' x 2' RECESSED LED PANEL LIGHT, 20W, 4000K, DIMMABLE
40	10	2' x 2' RECESSED LED PANEL LIGHT, 20W, 4000K, DIMMABLE
41	10	2' x 2' RECESSED LED PANEL LIGHT, 20W, 4000K, DIMMABLE
42	10	2' x 2' RECESSED LED PANEL LIGHT, 20W, 4000K, DIMMABLE
43	10	2' x 2' RECESSED LED PANEL LIGHT, 20W, 4000K, DIMMABLE
44	10	2' x 2' RECESSED LED PANEL LIGHT, 20W, 4000K, DIMMABLE
45	10	2' x 2' RECESSED LED PANEL LIGHT, 20W, 4000K, DIMMABLE
46	10	2' x 2' RECESSED LED PANEL LIGHT, 20W, 4000K, DIMMABLE
47	10	2' x 2' RECESSED LED PANEL LIGHT, 20W, 4000K, DIMMABLE
48	10	2' x 2' RECESSED LED PANEL LIGHT, 20W, 4000K, DIMMABLE
49	10	2' x 2' RECESSED LED PANEL LIGHT, 20W, 4000K, DIMMABLE
50	10	2' x 2' RECESSED LED PANEL LIGHT, 20W, 4000K, DIMMABLE
51	10	2' x 2' RECESSED LED PANEL LIGHT, 20W, 4000K, DIMMABLE
52	10	2' x 2' RECESSED LED PANEL LIGHT, 20W, 4000K, DIMMABLE
53	10	2' x 2' RECESSED LED PANEL LIGHT, 20W, 4000K, DIMMABLE
54	10	2' x 2' RECESSED LED PANEL LIGHT, 20W, 4000K, DIMMABLE
55	10	2' x 2' RECESSED LED PANEL LIGHT, 20W, 4000K, DIMMABLE
56	10	2' x 2' RECESSED LED PANEL LIGHT, 20W, 4000K, DIMMABLE
57	10	2' x 2' RECESSED LED PANEL LIGHT, 20W, 4000K, DIMMABLE
58	10	2' x 2' RECESSED LED PANEL LIGHT, 20W, 4000K, DIMMABLE
59	10	2' x 2' RECESSED LED PANEL LIGHT, 20W, 4000K, DIMMABLE
60	10	2' x 2' RECESSED LED PANEL LIGHT, 20W, 4000K, DIMMABLE
61	10	2' x 2' RECESSED LED PANEL LIGHT, 20W, 4000K, DIMMABLE
62	10	2' x 2' RECESSED LED PANEL LIGHT, 20W, 4000K, DIMMABLE
63	10	2' x 2' RECESSED LED PANEL LIGHT, 20W, 4000K, DIMMABLE
64	10	2' x 2' RECESSED LED PANEL LIGHT, 20W, 4000K, DIMMABLE
65	10	2' x 2' RECESSED LED PANEL LIGHT, 20W, 4000K, DIMMABLE
66	10	2' x 2' RECESSED LED PANEL LIGHT, 20W, 4000K, DIMMABLE
67	10	2' x 2' RECESSED LED PANEL LIGHT, 20W, 4000K, DIMMABLE
68	10	2' x 2' RECESSED LED PANEL LIGHT, 20W, 4000K, DIMMABLE
69	10	2' x 2' RECESSED LED PANEL LIGHT, 20W, 4000K, DIMMABLE
70	10	2' x 2' RECESSED LED PANEL LIGHT, 20W, 4000K, DIMMABLE
71	10	2' x 2' RECESSED LED PANEL LIGHT, 20W, 4000K, DIMMABLE
72	10	2' x 2' RECESSED LED PANEL LIGHT, 20W, 4000K, DIMMABLE
73	10	2' x 2' RECESSED LED PANEL LIGHT, 20W, 4000K, DIMMABLE
74	10	2' x 2' RECESSED LED PANEL LIGHT, 20W, 4000K, DIMMABLE
75	10	2' x 2' RECESSED LED PANEL LIGHT, 20W, 4000K, DIMMABLE
76	10	2' x 2' RECESSED LED PANEL LIGHT, 20W, 4000K, DIMMABLE
77	10	2' x 2' RECESSED LED PANEL LIGHT, 20W, 4000K, DIMMABLE
78	10	2' x 2' RECESSED LED PANEL LIGHT, 20W, 4000K, DIMMABLE
79	10	2' x 2' RECESSED LED PANEL LIGHT, 20W, 4000K, DIMMABLE
80	10	2' x 2' RECESSED LED PANEL LIGHT, 20W, 4000K, DIMMABLE
81	10	2' x 2' RECESSED LED PANEL LIGHT, 20W, 4000K, DIMMABLE
82	10	2' x 2' RECESSED LED PANEL LIGHT, 20W, 4000K, DIMMABLE
83	10	2' x 2' RECESSED LED PANEL LIGHT, 20W, 4000K, DIMMABLE
84	10	2' x 2' RECESSED LED PANEL LIGHT, 20W, 4000K, DIMMABLE
85	10	2' x 2' RECESSED LED PANEL LIGHT, 20W, 4000K, DIMMABLE
86	10	2' x 2' RECESSED LED PANEL LIGHT, 20W, 4000K, DIMMABLE
87	10	2' x 2' RECESSED LED PANEL LIGHT, 20W, 4000K, DIMMABLE
88	10	2' x 2' RECESSED LED PANEL LIGHT, 20W, 4000K, DIMMABLE
89	10	2' x 2' RECESSED LED PANEL LIGHT, 20W, 4000K, DIMMABLE
90	10	2' x 2' RECESSED LED PANEL LIGHT, 20W, 4000K, DIMMABLE
91	10	2' x 2' RECESSED LED PANEL LIGHT, 20W, 4000K, DIMMABLE
92	10	2' x 2' RECESSED LED PANEL LIGHT, 20W, 4000K, DIMMABLE
93	10	2' x 2' RECESSED LED PANEL LIGHT, 20W, 4000K, DIMMABLE
94	10	2' x 2' RECESSED LED PANEL LIGHT, 20W, 4000K, DIMMABLE
95	10	2' x 2' RECESSED LED PANEL LIGHT, 20W, 4000K, DIMMABLE
96	10	2' x 2' RECESSED LED PANEL LIGHT, 20W, 4000K, DIMMABLE
97	10	2' x 2' RECESSED LED PANEL LIGHT, 20W, 4000K, DIMMABLE
98	10	2' x 2' RECESSED LED PANEL LIGHT, 20W, 4000K, DIMMABLE
99	10	2' x 2' RECESSED LED PANEL LIGHT, 20W, 4000K, DIMMABLE
100	10	2' x 2' RECESSED LED PANEL LIGHT, 20W, 4000K, DIMMABLE

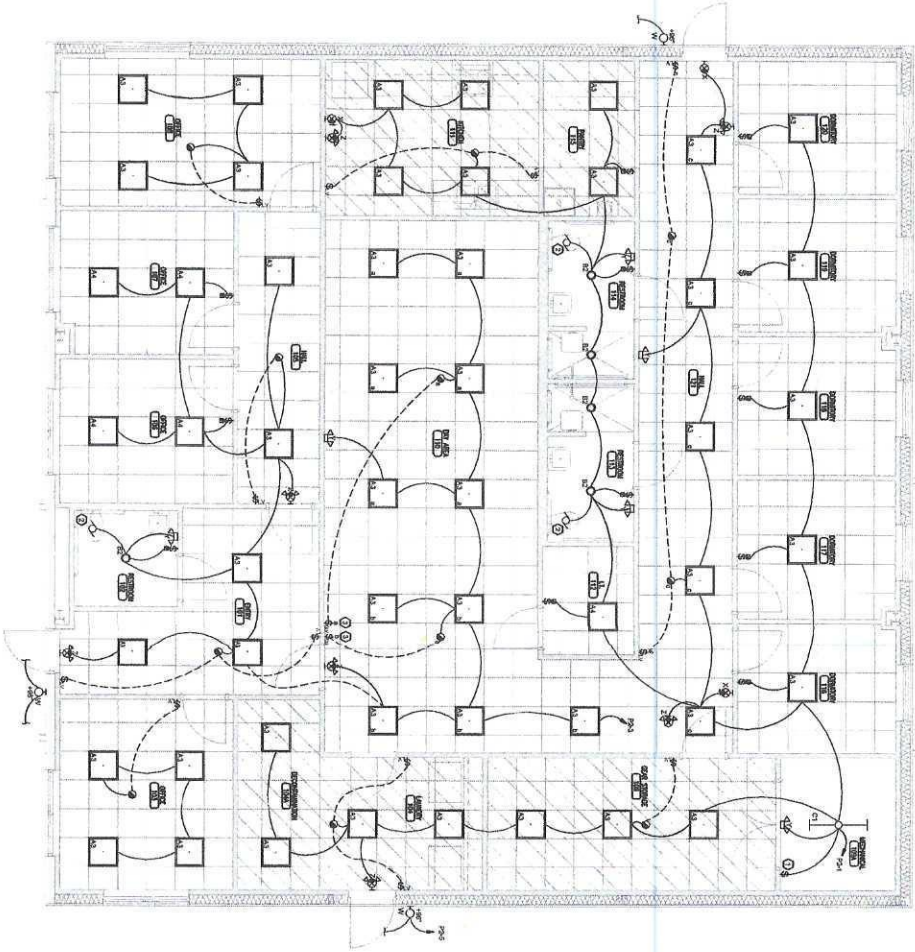

LIGHTING PLAN
SCALE: 1/4" = 1'-0"

SHEET NOTES

1. REFER TO THE GENERAL NOTES FOR THE PROJECT.
2. ALL LIGHTING FIXTURES SHALL BE INSTALLED IN ACCORDANCE WITH THE MANUFACTURER'S INSTALLATION INSTRUCTIONS.
3. ALL LIGHTING FIXTURES SHALL BE INSTALLED IN ACCORDANCE WITH THE NATIONAL ELECTRICAL CODE (NEC).
4. ALL LIGHTING FIXTURES SHALL BE INSTALLED IN ACCORDANCE WITH THE ILLINOIS ELECTRICAL CODE (IEC).
5. ALL LIGHTING FIXTURES SHALL BE INSTALLED IN ACCORDANCE WITH THE CITY OF CHICAGO ELECTRICAL CODE (CCOEC).
6. ALL LIGHTING FIXTURES SHALL BE INSTALLED IN ACCORDANCE WITH THE STATE OF ILLINOIS ELECTRICAL CODE (ISEC).
7. ALL LIGHTING FIXTURES SHALL BE INSTALLED IN ACCORDANCE WITH THE FEDERAL ELECTRICAL CODE (FEC).
8. ALL LIGHTING FIXTURES SHALL BE INSTALLED IN ACCORDANCE WITH THE INTERNATIONAL ELECTRIC CODE (IEC).
9. ALL LIGHTING FIXTURES SHALL BE INSTALLED IN ACCORDANCE WITH THE NATIONAL FIRE PROTECTION ASSOCIATION (NFPA) CODE.
10. ALL LIGHTING FIXTURES SHALL BE INSTALLED IN ACCORDANCE WITH THE AMERICAN NATIONAL STANDARDS INSTITUTE (ANSI) CODE.

SHEET KEYNOTES

1. DIMENSIONS TO FACE UNLESS NOTED OTHERWISE.
2. FINISHES TO BE DETERMINED BY THE ARCHITECT.
3. ALL WORK SHALL BE IN ACCORDANCE WITH THE LATEST EDITIONS OF THE NATIONAL ELECTRICAL CODE (NEC) AND THE ILLINOIS ELECTRICAL CODE (IEC).
4. ALL WORK SHALL BE IN ACCORDANCE WITH THE LATEST EDITIONS OF THE CITY OF CHICAGO ELECTRICAL CODE (CCOEC) AND THE STATE OF ILLINOIS ELECTRICAL CODE (ISEC).
5. ALL WORK SHALL BE IN ACCORDANCE WITH THE LATEST EDITIONS OF THE FEDERAL ELECTRICAL CODE (FEC) AND THE INTERNATIONAL ELECTRIC CODE (IEC).
6. ALL WORK SHALL BE IN ACCORDANCE WITH THE LATEST EDITIONS OF THE NATIONAL FIRE PROTECTION ASSOCIATION (NFPA) CODE AND THE AMERICAN NATIONAL STANDARDS INSTITUTE (ANSI) CODE.

COBURN AND ASSOCIATES
 ARCHITECTS
 1500 N. LAKE JEFFERY ROAD
 LAKE CITY, FLORIDA 32709
 PHONE: 407.521.1234
 FAX: 407.521.1235
 WWW.COBUARN.COM

DATE: 09/17/2024
 SHEET: 2338
 PROJECT: E201

LIGHTING
 CONSTRUCTION DOCUMENTS

NO.	DATE	BY	DESCRIPTION

NEW FIRE DEPARTMENT ADMINISTRATION BUILDING
 1570 N. LAKE JEFFERY ROAD
 LAKE CITY, FLORIDA
 COBCC PROJECT NUMBER

PRELIMINARY DESIGN FOR OWNER REVIEW
 NOT APPROVED FOR CONSTRUCTION

ARCHITECTURE & INTERIORS
 1500 N. LAKE JEFFERY ROAD
 LAKE CITY, FLORIDA 32709
 PHONE: 407.521.1234
 FAX: 407.521.1235
 WWW.ANDI.COM

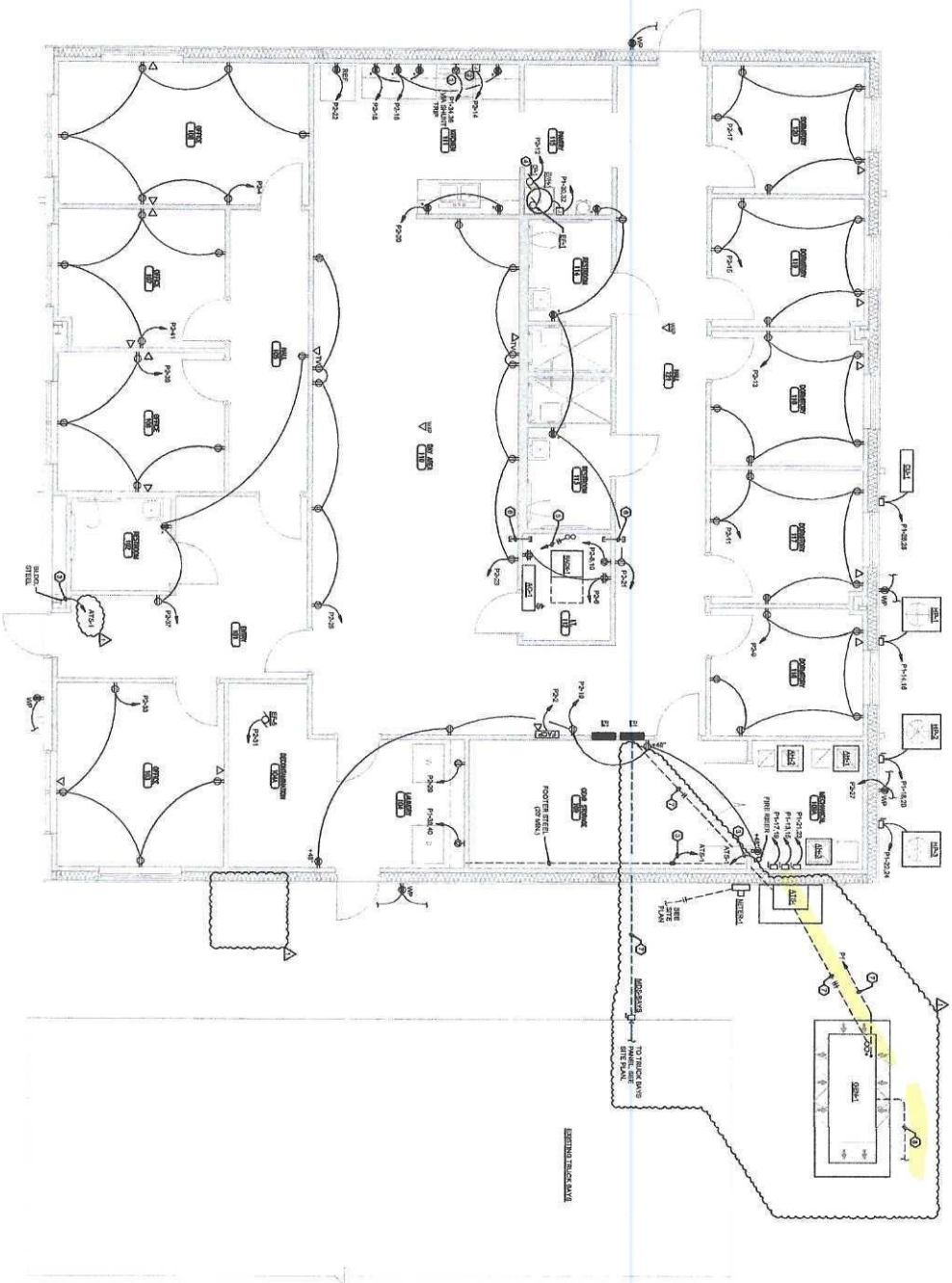

POWER AND SYSTEMS PLAN
SCALE 1/4" = 1'-0"

SHEET NOTES

A. NOT USED THIS SHEET

① SHEET KEYNOTES

1. APPLICABLE CODES SHALL BE INDICATED THROUGHOUT.
2. ALL NEW CONNECTIONS TO EXISTING SYSTEMS SHALL BE INDICATED THROUGHOUT.
3. ALL NEW WATER RESERVATION SHALL BE INDICATED THROUGHOUT.
4. DATE TO INDICATE FOR TELECOM AND DATA SHALL BE INDICATED THROUGHOUT.
5. ALL NEW TELECOM AND DATA SHALL BE INDICATED THROUGHOUT.
6. ALL NEW TELECOM AND DATA SHALL BE INDICATED THROUGHOUT.

COBURN AND ASSOCIATES
2238
09/17/2024
CONSTRUCTION DOCUMENTS

DATE: 09/17/2024
2238
E2022

POWER
CONSTRUCTION DOCUMENTS

NO.	REVISION	DATE	BY

NEW FIRE DEPARTMENT ADMINISTRATION BUILDING
1579 NW LAKE JEFFERY ROAD
LAKE CITY, FLORIDA
COBCC PROJECT NUMBER

PRELIMINARY DESIGN REVISION FOR OWNER REVIEW
NOT APPROVED FOR CONSTRUCTION

ARCHITECTURE & INTERIORS
ADDRESS • GAINESVILLE, FLORIDA • 352-399-0000

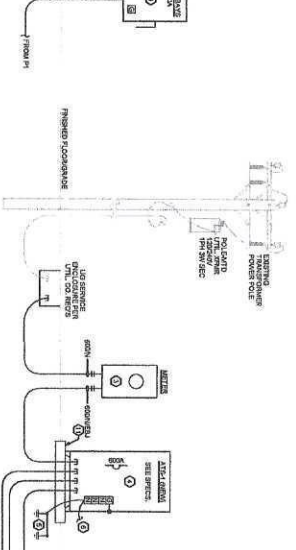
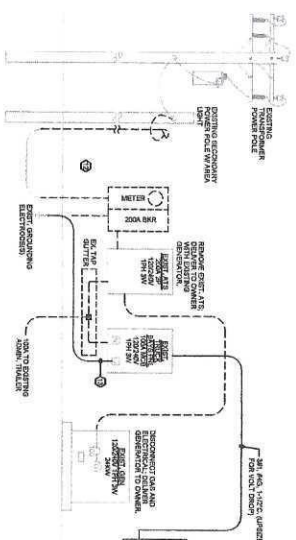

ELECTRICAL RISER DIAGRAM (MODIFICATIONS AT TRUCK BAYS BUILDING)

ELECTRICAL RISER DIAGRAM (NEW ADMIN BUILDING)

GENERATOR SPECS:

1. GENERATOR SHALL BE A DIESEL ENGINE DRIVEN GENERATOR WITH A MINIMUM OUTPUT OF 1000 KW.
2. GENERATOR SHALL BE CAPABLE OF OPERATING AT 480V, 3PH, 3W, 4W, 50/60 HZ.
3. GENERATOR SHALL BE CAPABLE OF OPERATING AT 480V, 3PH, 3W, 4W, 50/60 HZ.
4. GENERATOR SHALL BE CAPABLE OF OPERATING AT 480V, 3PH, 3W, 4W, 50/60 HZ.
5. GENERATOR SHALL BE CAPABLE OF OPERATING AT 480V, 3PH, 3W, 4W, 50/60 HZ.
6. GENERATOR SHALL BE CAPABLE OF OPERATING AT 480V, 3PH, 3W, 4W, 50/60 HZ.
7. GENERATOR SHALL BE CAPABLE OF OPERATING AT 480V, 3PH, 3W, 4W, 50/60 HZ.
8. GENERATOR SHALL BE CAPABLE OF OPERATING AT 480V, 3PH, 3W, 4W, 50/60 HZ.
9. GENERATOR SHALL BE CAPABLE OF OPERATING AT 480V, 3PH, 3W, 4W, 50/60 HZ.
10. GENERATOR SHALL BE CAPABLE OF OPERATING AT 480V, 3PH, 3W, 4W, 50/60 HZ.

ATS SPECS:

1. ATS SHALL BE CAPABLE OF SWITCHING BETWEEN THE MAIN POWER SOURCE AND THE GENERATOR.
2. ATS SHALL BE CAPABLE OF SWITCHING BETWEEN THE MAIN POWER SOURCE AND THE GENERATOR.
3. ATS SHALL BE CAPABLE OF SWITCHING BETWEEN THE MAIN POWER SOURCE AND THE GENERATOR.
4. ATS SHALL BE CAPABLE OF SWITCHING BETWEEN THE MAIN POWER SOURCE AND THE GENERATOR.
5. ATS SHALL BE CAPABLE OF SWITCHING BETWEEN THE MAIN POWER SOURCE AND THE GENERATOR.
6. ATS SHALL BE CAPABLE OF SWITCHING BETWEEN THE MAIN POWER SOURCE AND THE GENERATOR.
7. ATS SHALL BE CAPABLE OF SWITCHING BETWEEN THE MAIN POWER SOURCE AND THE GENERATOR.
8. ATS SHALL BE CAPABLE OF SWITCHING BETWEEN THE MAIN POWER SOURCE AND THE GENERATOR.
9. ATS SHALL BE CAPABLE OF SWITCHING BETWEEN THE MAIN POWER SOURCE AND THE GENERATOR.
10. ATS SHALL BE CAPABLE OF SWITCHING BETWEEN THE MAIN POWER SOURCE AND THE GENERATOR.

ALTERNATES:

1. ALTERNATE 1: GENERATOR SHALL BE A DIESEL ENGINE DRIVEN GENERATOR WITH A MINIMUM OUTPUT OF 1000 KW.
2. ALTERNATE 2: GENERATOR SHALL BE A DIESEL ENGINE DRIVEN GENERATOR WITH A MINIMUM OUTPUT OF 1000 KW.
3. ALTERNATE 3: GENERATOR SHALL BE A DIESEL ENGINE DRIVEN GENERATOR WITH A MINIMUM OUTPUT OF 1000 KW.
4. ALTERNATE 4: GENERATOR SHALL BE A DIESEL ENGINE DRIVEN GENERATOR WITH A MINIMUM OUTPUT OF 1000 KW.
5. ALTERNATE 5: GENERATOR SHALL BE A DIESEL ENGINE DRIVEN GENERATOR WITH A MINIMUM OUTPUT OF 1000 KW.
6. ALTERNATE 6: GENERATOR SHALL BE A DIESEL ENGINE DRIVEN GENERATOR WITH A MINIMUM OUTPUT OF 1000 KW.
7. ALTERNATE 7: GENERATOR SHALL BE A DIESEL ENGINE DRIVEN GENERATOR WITH A MINIMUM OUTPUT OF 1000 KW.
8. ALTERNATE 8: GENERATOR SHALL BE A DIESEL ENGINE DRIVEN GENERATOR WITH A MINIMUM OUTPUT OF 1000 KW.
9. ALTERNATE 9: GENERATOR SHALL BE A DIESEL ENGINE DRIVEN GENERATOR WITH A MINIMUM OUTPUT OF 1000 KW.
10. ALTERNATE 10: GENERATOR SHALL BE A DIESEL ENGINE DRIVEN GENERATOR WITH A MINIMUM OUTPUT OF 1000 KW.

FEEDER SCHEDULE

FEEDER NO.	TO	FROM	TYPE	SIZE	LENGTH	LOAD	TYPE	SIZE	LENGTH	LOAD
1	100	101	3W	3"	100'	1000	3W	3"	100'	1000
2	100	102	3W	3"	100'	1000	3W	3"	100'	1000
3	100	103	3W	3"	100'	1000	3W	3"	100'	1000
4	100	104	3W	3"	100'	1000	3W	3"	100'	1000
5	100	105	3W	3"	100'	1000	3W	3"	100'	1000
6	100	106	3W	3"	100'	1000	3W	3"	100'	1000
7	100	107	3W	3"	100'	1000	3W	3"	100'	1000
8	100	108	3W	3"	100'	1000	3W	3"	100'	1000
9	100	109	3W	3"	100'	1000	3W	3"	100'	1000
10	100	110	3W	3"	100'	1000	3W	3"	100'	1000

SHORT CIRCUIT CALCULATIONS

TYPE	NO.	TO	FROM	TYPE	SIZE	LENGTH	LOAD	TYPE	SIZE	LENGTH	LOAD
1	100	101	100	3W	3"	100'	1000	3W	3"	100'	1000
2	100	102	100	3W	3"	100'	1000	3W	3"	100'	1000
3	100	103	100	3W	3"	100'	1000	3W	3"	100'	1000
4	100	104	100	3W	3"	100'	1000	3W	3"	100'	1000
5	100	105	100	3W	3"	100'	1000	3W	3"	100'	1000
6	100	106	100	3W	3"	100'	1000	3W	3"	100'	1000
7	100	107	100	3W	3"	100'	1000	3W	3"	100'	1000
8	100	108	100	3W	3"	100'	1000	3W	3"	100'	1000
9	100	109	100	3W	3"	100'	1000	3W	3"	100'	1000
10	100	110	100	3W	3"	100'	1000	3W	3"	100'	1000

1-PHASE PANEL SCHEDULE

NO.	TO	FROM	TYPE	SIZE	LENGTH	LOAD	TYPE	SIZE	LENGTH	LOAD
1	100	101	3W	3"	100'	1000	3W	3"	100'	1000
2	100	102	3W	3"	100'	1000	3W	3"	100'	1000
3	100	103	3W	3"	100'	1000	3W	3"	100'	1000
4	100	104	3W	3"	100'	1000	3W	3"	100'	1000
5	100	105	3W	3"	100'	1000	3W	3"	100'	1000
6	100	106	3W	3"	100'	1000	3W	3"	100'	1000
7	100	107	3W	3"	100'	1000	3W	3"	100'	1000
8	100	108	3W	3"	100'	1000	3W	3"	100'	1000
9	100	109	3W	3"	100'	1000	3W	3"	100'	1000
10	100	110	3W	3"	100'	1000	3W	3"	100'	1000

SHEET NOTES

1. PROVIDE BREAKER WITH COORDINATION AND TRIP CURVE.
2. PROVIDE BREAKER WITH COORDINATION AND TRIP CURVE.
3. PROVIDE BREAKER WITH COORDINATION AND TRIP CURVE.
4. PROVIDE BREAKER WITH COORDINATION AND TRIP CURVE.
5. PROVIDE BREAKER WITH COORDINATION AND TRIP CURVE.
6. PROVIDE BREAKER WITH COORDINATION AND TRIP CURVE.
7. PROVIDE BREAKER WITH COORDINATION AND TRIP CURVE.
8. PROVIDE BREAKER WITH COORDINATION AND TRIP CURVE.
9. PROVIDE BREAKER WITH COORDINATION AND TRIP CURVE.
10. PROVIDE BREAKER WITH COORDINATION AND TRIP CURVE.

NEW EQUIPMENT SCHEDULE

NO.	DESCRIPTION	QTY	MAKE	MODEL	CONNECTIONS	REMARKS
1	480V BUS	1	ABB	1000	480V	
2	480V BUS	1	ABB	1000	480V	
3	480V BUS	1	ABB	1000	480V	
4	480V BUS	1	ABB	1000	480V	
5	480V BUS	1	ABB	1000	480V	
6	480V BUS	1	ABB	1000	480V	
7	480V BUS	1	ABB	1000	480V	
8	480V BUS	1	ABB	1000	480V	
9	480V BUS	1	ABB	1000	480V	
10	480V BUS	1	ABB	1000	480V	

1-PHASE PANEL SCHEDULE

NO.	TO	FROM	TYPE	SIZE	LENGTH	LOAD	TYPE	SIZE	LENGTH	LOAD
1	100	101	3W	3"	100'	1000	3W	3"	100'	1000
2	100	102	3W	3"	100'	1000	3W	3"	100'	1000
3	100	103	3W	3"	100'	1000	3W	3"	100'	1000
4	100	104	3W	3"	100'	1000	3W	3"	100'	1000
5	100	105	3W	3"	100'	1000	3W	3"	100'	1000
6	100	106	3W	3"	100'	1000	3W	3"	100'	1000
7	100	107	3W	3"	100'	1000	3W	3"	100'	1000
8	100	108	3W	3"	100'	1000	3W	3"	100'	1000
9	100	109	3W	3"	100'	1000	3W	3"	100'	1000
10	100	110	3W	3"	100'	1000	3W	3"	100'	1000

1-PHASE PANEL SCHEDULE

NO.	TO	FROM	TYPE	SIZE	LENGTH	LOAD	TYPE	SIZE	LENGTH	LOAD
1	100	101	3W	3"	100'	1000	3W	3"	100'	1000
2	100	102	3W	3"	100'	1000	3W	3"	100'	1000
3	100	103	3W	3"	100'	1000	3W	3"	100'	1000
4	100	104	3W	3"	100'	1000	3W	3"	100'	1000
5	100	105	3W	3"	100'	1000	3W	3"	100'	1000
6	100	106	3W	3"	100'	1000	3W	3"	100'	1000
7	100	107	3W	3"	100'	1000	3W	3"	100'	1000
8	100	108	3W	3"	100'	1000	3W	3"	100'	1000
9	100	109	3W	3"	100'	1000	3W	3"	100'	1000
10	100	110	3W	3"	100'	1000	3W	3"	100'	1000

1-PHASE PANEL SCHEDULE

NO.	TO	FROM	TYPE	SIZE	LENGTH	LOAD	TYPE	SIZE	LENGTH	LOAD
1	100	101	3W	3"	100'	1000	3W	3"	100'	1000
2	100	102	3W	3"	100'	1000	3W	3"	100'	1000
3	100	103	3W	3"	100'	1000	3W	3"	100'	1000
4	100	104	3W	3"	100'	1000	3W	3"	100'	1000
5	100	105	3W	3"	100'	1000	3W	3"	100'	1000
6	100	106	3W	3"	100'	1000	3W	3"	100'	1000
7	100	107	3W	3"	100'	1000	3W	3"	100'	1000
8	100	108	3W	3"	100'	1000	3W	3"	100'	1000
9	100	109	3W	3"	100'	1000	3W	3"	100'	1000
10	100	110	3W	3"	100'	1000	3W	3"	100'	1000

COBURN AND ASSOCIATES
 PROFESSIONAL ENGINEERS
 1000 N. W. 10th Ave., Suite 1000
 Fort Lauderdale, FL 33304
 PHONE: (954) 576-1111
 FAX: (954) 576-1112
 WWW: www.coburnandassociates.com

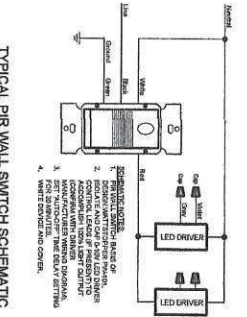

TYPICAL PIR WALL SWITCH SCHEMATIC

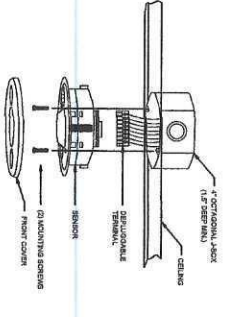

TYPICAL CEILING SENSOR MOUNTING

- REMOVE SENSORS ON NOTES EQUIPMENT:**
1. REMOVE SENSORS FROM NOTES EQUIPMENT.
 2. REMOVE SENSORS FROM NOTES EQUIPMENT.
 3. REMOVE SENSORS FROM NOTES EQUIPMENT.
 4. REMOVE SENSORS FROM NOTES EQUIPMENT.
- REMOVE SENSORS FROM NOTES EQUIPMENT:**
1. REMOVE SENSORS FROM NOTES EQUIPMENT.
 2. REMOVE SENSORS FROM NOTES EQUIPMENT.
 3. REMOVE SENSORS FROM NOTES EQUIPMENT.
 4. REMOVE SENSORS FROM NOTES EQUIPMENT.
- REMOVE SENSORS FROM NOTES EQUIPMENT:**
1. REMOVE SENSORS FROM NOTES EQUIPMENT.
 2. REMOVE SENSORS FROM NOTES EQUIPMENT.
 3. REMOVE SENSORS FROM NOTES EQUIPMENT.
 4. REMOVE SENSORS FROM NOTES EQUIPMENT.

EXAMPLE NAMEPLATE DETAILS

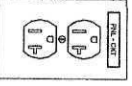

RECEPTACLES SHALL BE INSTALLED WITH GROUND PIN FIRST AND NEUTRAL PIN SECOND. AFTER CHANGE OF NEUTRAL AND GROUND BONDING POINTS, RECEPTACLES SHALL BE INSTALLED WITH GROUND PIN FIRST AND NEUTRAL PIN SECOND.

TYPICAL RECEPTACLE DETAIL

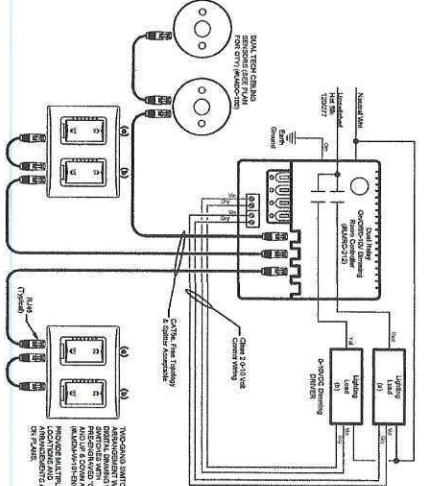

MULTIPLE DIMMING CIRCUITS & CEILING SENSOR SCHEMATIC

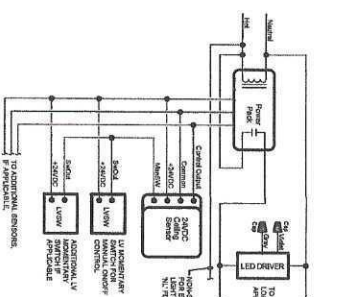

HOT WATER RECIRCULATION PUMP CONTROL DIAGRAM

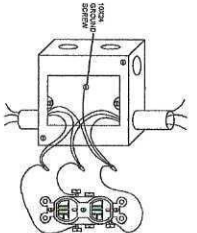

1. GROUNDING CONDUCTORS SHALL BE CONNECTED TO THE GROUNDING TERMINAL OF THE OUTLET.
2. HOT CONDUCTORS SHALL BE CONNECTED TO THE HOT TERMINAL OF THE OUTLET.
3. NEUTRAL CONDUCTORS SHALL BE CONNECTED TO THE NEUTRAL TERMINAL OF THE OUTLET.
4. NEUTRAL CONDUCTORS SHALL BE CONNECTED TO THE NEUTRAL TERMINAL OF THE OUTLET.

TYPICAL OUTLET WIRING DETAIL

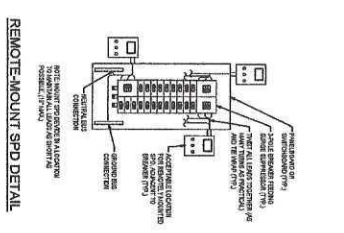

REMOTE-MOUNT SPD DETAIL

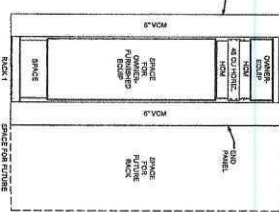

I.T. ROOM RACK DETAIL

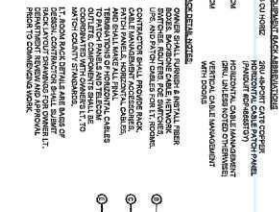

TYPICAL TELECOM OUTLET DETAIL (CATB)

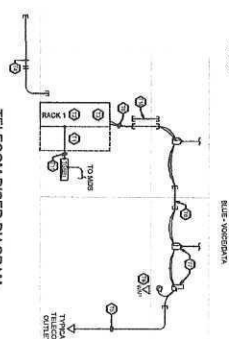

TELECOM RISER DIAGRAM

COBBURN AND ASSOCIATES
 ARCHITECTURE & INTERIORS
 1515 N. W. 10TH AVENUE, SUITE 100
 MIAMI, FLORIDA 33136
 PHONE: 305.575.1100
 FAX: 305.575.1101
 WWW.COBBURNANDASSOCIATES.COM

GENERAC INDUSTRIAL
POWER

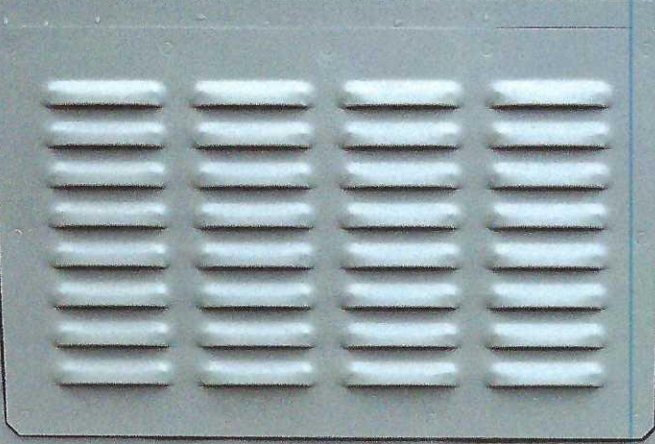

EMERGENCY
DISCONNECT
SERVICE
DISCONNECT

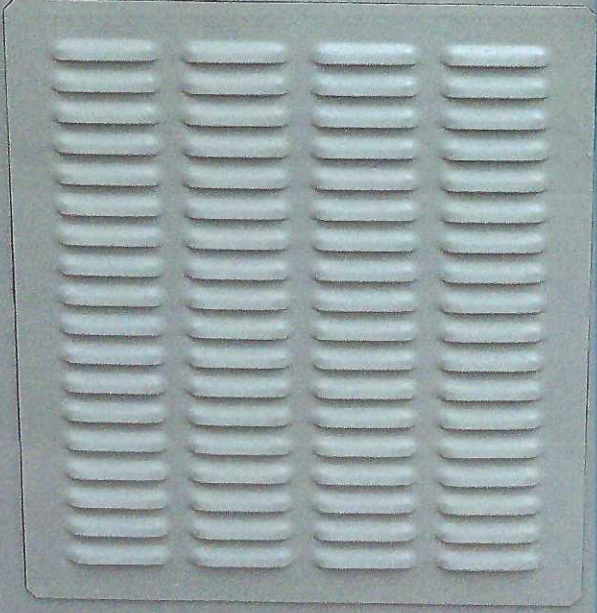

MEYER



SHORT-CIRCUIT WITHSTAND/CLOSING RATINGS

THIS TRANSFER SWITCH IS SUITABLE FOR USE IN A CIRCUIT CAPABLE OF DELIVERING THE SHORT-CIRCUIT CURRENT FOR THE MAXIMUM RATED VOLTAGE MARKED BELOW. WHEN PROTECTED BY A CIRCUIT BREAKER, IT SHALL NOT INCLUDE A SHORT-TIME TRIP RESPONSE.

SHORT-CIRCUIT CURRENT (RMS SYMMETRICAL AMPERES X 1000)	VOLTAGE (VOLTS AC MAXIMUM)
100	480
35	600

SHORT-TIME CURRENT RATINGS

THIS TRANSFER SWITCH DOES NOT INCLUDE
SHORT-TIME CURRENT RATINGS

TIGHTENING TORQUE
WIRE SIZE -- TORQUE lb/in (Nm)

CIRCUIT BREAKER: (2)600 - 2/0
SWITCH CONTACTOR: 2) 750 - 2 -- 620 (70)
NEUTRAL: 600-4 OR(2)250-1/0 - 375(42.4)
GROUND: 350 - 6 -- 275 (31.1)
CONTROL WIRING: 12 - 30 -- 5.5 lb/in (.62)

S/N 3017925974

A0000592317C

SECTION XII. FORMS

VENDOR INFORMATION AND SIGNATURE FORM

Vendor Name	
Trade License (If applicable)	
Contact Person(s)	
Street Address with City, State and Zip Code	
Mailing Address (If different from Above)	
Phone Number	
Fax Number	
E-Mail	
Proposer will do the work as	<input type="checkbox"/> Individual <input type="checkbox"/> Joint Venture <input type="checkbox"/> Partnership <input type="checkbox"/> Corporation
Date and State of Incorporation	DATE: _____ STATE: _____
Name of partnership or joint venture	

By signing below, the submission of qualifications shall be deemed a representation and certification by the Proposing Firm that you have investigated all aspects of the RFP, have read and understand the RFP, and acknowledge all addenda.

Authorized Signature:
Printed Name of Signer:
Date Signed:
Title of Signatory:

Dated this _____ day of _____, _____.

Name of Organization: _____

Signed by: _____

Print Name: _____

Being duly sworn deposes and says that the information herein is true and sufficiently complete so as not to be misleading.

The foregoing instrument was executed before me this day _____ of _____ 20____, by _____ as _____ of _____, who personally swore or affirmed that he/she is authorized to execute this document and thereby bind the Corporation, and who is personally known to me OR has produced _____ as identification.

(stamp)

NOTARY PUBLIC, State of _____

Public Entity Crimes Statement

SWORN STATEMENT UNDER SECTION 287.133(3) (a), FLORIDA STATUTES: THIS FORM MUST BE SIGNED IN THE PRESENCE OF A NOTARY PUBLIC OR OTHER OFFICER AUTHORIZED TO ADMINISTER OATHS.

1. This sworn statement is submitted with Proposal, ITN, or Contract Number
2. This sworn statement is submitted by _____
[Name of entity submitting sworn statement]
whose business address is _____ and (if applicable) its Federal Employer Identification Number (FEIN) is _____
(If the entity has no FEIN, include the Social Security Number of the individual signing this sworn statement: _____.
3. My name is _____ and my relationship to the above is _____
[Please print name of individual signing]
4. I understand that a "public entity crime" as defined in section 287.133(1)(g), Florida Statutes, means a violation of any state or federal law by a person with respect to and directly related to the transaction of business with any public entity in Florida or with an agency or political subdivision of any other state or with the United States, including, but not limited to, any proposal or contract for goods or services to be provided to any public entity or an agency or political subdivision and involving antitrust, fraud, theft, bribery, collusion, racketeering, conspiracy, or material misrepresentation.
5. I understand that "convicted" or "conviction" as defined in section 287.133(1) (b), Florida Statutes, means a finding of guilt or a conviction of a public entity crime, with or without an adjudication of guilt, in any federal or state trial court of record relating to charges brought by indictment or information after July 1, 1989, as a result of a jury verdict, non-jury trial, or entry of a plea of guilty or nolo contendere.
6. I understand that "affiliate" as defined in section 287.133(1) (a), Florida Statutes, means:
 - a. A predecessor or successor of a person convicted of a public entity crime; or
 - b. An entity under the control of any natural person who is active in the management of the entity and who has been convicted of a public entity crime. The term "affiliate" includes those officers, directors, executives, partners, shareholders, employees, members, and agents who are active in the management of an affiliate. The ownership by one person of shares constituting a controlling interest in another person, or a pooling of equipment or income among persons when not for fair market value under an arm's length agreement, shall be a prima facie case that one person controls another person. A person who knowingly enters into a joint venture with a person who has been convicted of a public entity crime in Florida during the preceding thirty-six (36) months shall be considered an affiliate.

7. I understand that a "person" as defined in section 287.133(1) (e), Florida Statutes, means any natural person or entity organized under the laws of any state or of the United States with the legal power to enter into a binding contract and which bids/proposals or applies to bids/proposals on contracts for the provision of goods or services let by a public entity, or which otherwise transacts or applies to transact business with a public entity. The term "person" includes those officers, directors, executives, partners, shareholders, employees, members, and agents who are active in management of an entity.

8. Based on information and belief, the statement, which I have marked below, is true in relation to the entity submitting this sworn statement. **[Please indicate which statement applies].**

_____ Neither the entity submitting this sworn statement, nor any officers, directors, executives, partners, shareholders, employees, members, or agents who is active in the management of the entity, nor any affiliate of the entity have been convicted of a public entity crime subsequent to July 1, 1989.

_____ The entity submitting this sworn statement, or one or more of the officers, directors, executives, partners, shareholders, employees, members, or agents who are active in the management of the entity, or an affiliate of the entity has been charged with and convicted of a public entity crime subsequent to July 1, 1989, AND **[Please indicate which additional statement applies].**

_____ There has been a proceeding concerning the conviction before a judge or hearing officer of the State of Florida, Division of Administrative Hearings, or a court of law having proper jurisdiction. The final order entered by the hearing officer or judge did not place the person or affiliate on the convicted Contractor list. **[Please attach a copy of the final order.]**

_____ The person or affiliate was placed on the convicted Contractor list. There has been a subsequent proceeding before a court of law having proper jurisdiction or a judge or hearing officer of the State of Florida, Division of Administrative Hearings. The final order entered by the judge or hearing officer determined that it was in the public interest to remove the person or affiliate from the convicted Contractor list. **[Please attach a copy of the final order.]**

_____ The person or affiliate has not been placed on any convicted vendor list. [Please describe any action taken by or pending with the State of Florida, Department of Management Services.]

By the signature(s) below, I/we, the undersigned, as authorized signatory to commit the firm, certify that the information as provided in Attachment "C", Public Entity Crimes, is truthful and

correct at the time of submission.

AFFIANT

Typed Name of AFFIANT

Title

STATE OF _____

County OF _____

The foregoing instrument was executed before me this day _____ of _____
20____, by _____ as _____ of
_____, who personally swore or affirmed that
he/she is authorized to execute this document and thereby bind the Corporation, and who is
personally known to me OR has produced _____ as identification.

(stamp)

NOTARY PUBLIC, State of _____

Drug-Free Workplace Certification

The drug-free certification form below must be signed and returned with the solicitation response.

In order to have a drug-free workplace program, a business shall:

1. Publish a statement notifying employees that the unlawful manufacture, distribution, dispensing, possession, or use of a controlled substance is prohibited in the workplace and specifying the actions that will be taken against employees for violations of such prohibition.
2. Inform employees about the dangers of drug abuse in the workplace, the business' policy of maintaining a drug-free workplace, any available drug counseling, rehabilitation, and employee assistance programs, and the penalties that may be imposed upon employees for drug abuse violations.
3. Give each employee engaged in providing the commodities or contractual services that are under bid/proposal a copy of the statement specified in the first paragraph.
4. In the statement specified in the first paragraph, notify the employees that, as a condition of working on the commodities or contractual services that are under bid/proposal, the employee will abide by the terms of the statement and will notify the employer of any conviction of, or plea of guilty or nolo contendere to, any violation of chapter 893, Florida Statutes, or of any controlled substance law of the United States or any state, for a violation occurring in the workplace no later than five (5) Days after such conviction.
5. Impose a sanction on, or require the satisfactory participation in, a drug abuse assistance or rehabilitation program if such is available in the employee's community, by any employee who is so convicted.
6. Make a good faith effort to continue to maintain a drug-free workplace through implementation of the foregoing provisions.

By the signature(s) below, I/we, the undersigned, as authorized signatory to commit the firm, certify that the information as provided in this Drug-Free Workplace Certification, is truthful and correct at the time of submission.

AFFIANT

Typed Name of AFFIANT

Title

STATE OF _____

County OF _____

The foregoing instrument was executed before me this day _____ of _____
20____, by _____ as _____ of
_____, who personally swore or affirmed that
he/she is authorized to execute this document and thereby bind the Corporation, and who is
personally known to me OR has produced _____ as identification.

(stamp)

NOTARY PUBLIC, State of _____

Conflict of Interest Statement

STATE OF _____

County OF _____

Before me, the undersigned authority, personally appeared _____, who was duly sworn, deposes, and states:

I am the _____ of _____ with a local office
(Insert Title) (Insert Company Name)
in _____ and principal office in _____. Said entity is submitting this proposal/offer to

1. The AFFIANT has made diligent inquiry and provided the information in this statement affidavit based upon its full knowledge.
2. The AFFIANT states that only one submittal for this solicitation has been submitted and tendered by the appropriate date and time and that said above stated entity has no financial interest in other entities submitting a proposal for the work contemplated hereby.
3. Neither the AFFIANT nor the above named entity has directly or indirectly entered into any agreement, participated in any collusion or collusive activity, or otherwise taken any action which in any way restricts or restrains the competitive nature of this solicitation, including but not limited to the prior discussion of terms, conditions, pricing, or other offer parameters required by this solicitation.
4. Neither the entity nor its affiliates, nor anyone associated with them, is presently suspended or otherwise prohibited from participation in this solicitation or any contract to follow thereafter by any government entity.
5. Neither the entity nor its affiliates, nor anyone associated with them, have any potential conflict of interest because and due to any other clients, contracts, or property interests in this solicitation or the resulting project.
6. I hereby also certify that no member of the entity's ownership or management or staff has a vested interest in any County Office or Department.
7. I certify that no member of the entity's ownership or management is presently applying, actively seeking, or has been selected for an elected position within Columbia County government.
8. In the event that a conflict of interest is identified in the provision of services, I, the undersigned will immediately notify the County in writing.

AFFIANT

Typed Name of AFFIANT

Title

STATE OF _____

County OF _____

The foregoing instrument was executed before me this day _____ of _____
20____, by _____ as _____ of
_____, who personally swore or affirmed that
he/she is authorized to execute this document and thereby bind the Corporation, and who is
personally known to me OR has produced _____ as identification.

(stamp)

NOTARY PUBLIC, State of _____

**CERTIFICATE REGARDING LOBBYING AND DEBARMENT, SUSPENSION, AND
OTHER RESPONSIBILITY MATTERS**

1. Lobbying

As required by Section 1352, Title 31 of the U.S. Code, and implemented at 28 CFR Part 69, for persons entering into a grant or cooperative agreement over \$100,000, as defined at 28 CFR Part 69, the applicant certifies that:

- A. No federal appropriated funds have been paid or will be paid, by or on behalf of the undersigned, to any person for influencing or attempting to influence an officer or employee of any agency, a member of Congress, an officer or employee of Congress, or an employee of a member of Congress in connection with the making of any federal grant, the entering into of any cooperative agreement, and the extension, continuation, renewal, amendment, or modification of any federal grant or cooperative agreement.
- B. If any funds other than federal appropriated funds have been paid or will be paid to influence an officer or employee of any agency, a member of Congress, an officer or employee of Congress, or an employee of a member of Congress in connection with this federal grant or cooperative agreement, the undersigned shall complete and submit Standard Form LLL – “Disclosure of Lobbying Activities”, in accordance with its instructions.
- C. The undersigned shall require that the language of this certification be included in the award documents for all subawards at all tiers (including subgrants, contracts under grants and cooperative agreements, and subcontracts) and that all subrecipients shall certify and disclose accordingly.

2. Debarment, Suspension and Other Responsibility Matters

As required by Executive Order 12549, Debarment and Suspension, and implemented at 28 CFR Part 67 –

- A. The applicant certifies that it and its principals:
 - I. Are not presently debarred, suspended, proposed for debarment, declared ineligible, sentenced to a denial of federal benefits by a State or Federal court, or voluntarily excluded from covered transactions by any federal department or agency;
 - II. Have not within a three-year period preceding this application been convicted of or had a civil judgement rendered against them for commission of fraud or a criminal offense in connection with obtaining, attempting to obtain, or performing a public transaction; violation of Federal or State antitrust statutes or commission of embezzlement, theft forgery, bribery, falsification or destruction of records, making false statements, or receiving stolen property;

III. Are not presently indicted for or otherwise criminally or civilly charged by a governmental entity (Federal, State, or local) with commission of any of the offenses enumerated in paragraph (a)(ii) of this certification; and

IV. Have not within a three-year period preceding this application had one or more public transactions (Federal, State or local) terminated for cause or default. (b) Where the applicant is unable to certify to any of the statements in this certification, he or she shall attach an explanation to this application.

As the duly authorized representative of the applicant, I hereby certify that applicant will comply with the above referenced certifications.

AFFIANT

Typed Name of AFFIANT

Title

STATE OF _____

County OF _____

The foregoing instrument was executed before me this day _____ of _____
20____, by _____ as _____ of
_____, who personally swore or affirmed that
he/she is authorized to execute this document and thereby bind the Corporation, and who is
personally known to me OR has produced _____ as identification.

(stamp)

NOTARY PUBLIC, State of _____

HUMAN TRAFFICKING AFFIDAVIT

Affiant swears under pain and penalty of perjury that the company or entity does not use coercion for labor or services as defined by Florida Statute § 787.06 which is hereby incorporated by reference.

(Company or Entity Name)

Affiant who is an Officer/Authorized Representative of Company or Entity:

(Signature)

(Printed Name)

(Date)

STATE OF _____)

COUNTY OF _____)

Sworn to and subscribed before me this _____ day of _____, 202__ by _____, by means of physical presence and _____ who is personally known to me or _____ has produced _____ as identification.

(NOTARY STAMP)

Notary Public

By signing the filled-out form, you:

1. Certify that the TIN you are giving is correct (or you are waiting for a number to be issued),
2. Certify that you are not subject to backup withholding, or
3. Claim exemption from backup withholding if you are a U.S. exempt payee. If applicable, you are also certifying that as a U.S. person, your allocable share of any partnership income from a U.S. trade or business is not subject to the withholding tax on foreign partners' share of effectively connected income, and
4. Certify that FATCA code(s) entered on this form (if any) indicating that you are exempt from the FATCA reporting, is correct. See *What is FATCA reporting*, later, for further information.

Note: If you are a U.S. person and a requester gives you a form other than Form W-9 to request your TIN, you must use the requester's form if it is substantially similar to this Form W-9.

Definition of a U.S. person. For federal tax purposes, you are considered a U.S. person if you are:

- An individual who is a U.S. citizen or U.S. resident alien;
- A partnership, corporation, company, or association created or organized in the United States or under the laws of the United States;
- An estate (other than a foreign estate); or
- A domestic trust (as defined in Regulations section 301.7701-7).

Special rules for partnerships. Partnerships that conduct a trade or business in the United States are generally required to pay a withholding tax under section 1446 on any foreign partners' share of effectively connected taxable income from such business. Further, in certain cases where a Form W-9 has not been received, the rules under section 1446 require a partnership to presume that a partner is a foreign person, and pay the section 1446 withholding tax. Therefore, if you are a U.S. person that is a partner in a partnership conducting a trade or business in the United States, provide Form W-9 to the partnership to establish your U.S. status and avoid section 1446 withholding on your share of partnership income.

In the cases below, the following person must give Form W-9 to the partnership for purposes of establishing its U.S. status and avoiding withholding on its allocable share of net income from the partnership conducting a trade or business in the United States.

- In the case of a disregarded entity with a U.S. owner, the U.S. owner of the disregarded entity and not the entity;
- In the case of a grantor trust with a U.S. grantor or other U.S. owner, generally, the U.S. grantor or other U.S. owner of the grantor trust and not the trust; and
- In the case of a U.S. trust (other than a grantor trust), the U.S. trust (other than a grantor trust) and not the beneficiaries of the trust.

Foreign person. If you are a foreign person or the U.S. branch of a foreign bank that has elected to be treated as a U.S. person, do not use Form W-9. Instead, use the appropriate Form W-8 or Form 8233 (see Pub. 515, *Withholding of Tax on Nonresident Aliens and Foreign Entities*).

Nonresident alien who becomes a resident alien. Generally, only a nonresident alien individual may use the terms of a tax treaty to reduce or eliminate U.S. tax on certain types of income. However, most tax treaties contain a provision known as a "saving clause." Exceptions specified in the saving clause may permit an exemption from tax to continue for certain types of income even after the payee has otherwise become a U.S. resident alien for tax purposes.

If you are a U.S. resident alien who is relying on an exception contained in the saving clause of a tax treaty to claim an exemption from U.S. tax on certain types of income, you must attach a statement to Form W-9 that specifies the following five items.

1. The treaty country. Generally, this must be the same treaty under which you claimed exemption from tax as a nonresident alien.
2. The treaty article addressing the income.
3. The article number (or location) in the tax treaty that contains the saving clause and its exceptions.
4. The type and amount of income that qualifies for the exemption from tax.
5. Sufficient facts to justify the exemption from tax under the terms of the treaty article.

Example. Article 20 of the U.S.-China income tax treaty allows an exemption from tax for scholarship income received by a Chinese student temporarily present in the United States. Under U.S. law, this student will become a resident alien for tax purposes if his or her stay in the United States exceeds 5 calendar years. However, paragraph 2 of the first Protocol to the U.S.-China treaty (dated April 30, 1984) allows the provisions of Article 20 to continue to apply even after the Chinese student becomes a resident alien of the United States. A Chinese student who qualifies for this exception (under paragraph 2 of the first protocol) and is relying on this exception to claim an exemption from tax on his or her scholarship or fellowship income would attach to Form W-9 a statement that includes the information described above to support that exemption.

If you are a nonresident alien or a foreign entity, give the requester the appropriate completed Form W-8 or Form 8233.

Backup Withholding

What is backup withholding? Persons making certain payments to you must under certain conditions withhold and pay to the IRS 24% of such payments. This is called "backup withholding." Payments that may be subject to backup withholding include interest, tax-exempt interest, dividends, broker and barter exchange transactions, rents, royalties, nonemployee pay, payments made in settlement of payment card and third party network transactions, and certain payments from fishing boat operators. Real estate transactions are not subject to backup withholding.

You will not be subject to backup withholding on payments you receive if you give the requester your correct TIN, make the proper certifications, and report all your taxable interest and dividends on your tax return.

Payments you receive will be subject to backup withholding if:

1. You do not furnish your TIN to the requester,
2. You do not certify your TIN when required (see the instructions for Part II for details),
3. The IRS tells the requester that you furnished an incorrect TIN,
4. The IRS tells you that you are subject to backup withholding because you did not report all your interest and dividends on your tax return (for reportable interest and dividends only), or
5. You do not certify to the requester that you are not subject to backup withholding under 4 above (for reportable interest and dividend accounts opened after 1983 only).

Certain payees and payments are exempt from backup withholding. See *Exempt payee code*, later, and the separate instructions for the Requester of Form W-9 for more information.

Also see *Special rules for partnerships*, earlier.

What is FATCA Reporting?

The Foreign Account Tax Compliance Act (FATCA) requires a participating foreign financial institution to report all United States account holders that are specified United States persons. Certain payees are exempt from FATCA reporting. See *Exemption from FATCA reporting code*, later, and the instructions for the Requester of Form W-9 for more information.

Updating Your Information

You must provide updated information to any person to whom you claimed to be an exempt payee if you are no longer an exempt payee and anticipate receiving reportable payments in the future from this person. For example, you may need to provide updated information if you are a C corporation that elects to be an S corporation, or if you no longer are tax exempt. In addition, you must furnish a new Form W-9 if the name or TIN changes for the account; for example, if the grantor of a grantor trust dies.

Penalties

Failure to furnish TIN. If you fail to furnish your correct TIN to a requester, you are subject to a penalty of \$50 for each such failure unless your failure is due to reasonable cause and not to willful neglect.

Civil penalty for false information with respect to withholding. If you make a false statement with no reasonable basis that results in no backup withholding, you are subject to a \$500 penalty.

Criminal penalty for falsifying information. Willfully falsifying certifications or affirmations may subject you to criminal penalties including fines and/or imprisonment.

Misuse of TINs. If the requester discloses or uses TINs in violation of federal law, the requester may be subject to civil and criminal penalties.

Specific Instructions

Line 1

You must enter one of the following on this line; **do not** leave this line blank. The name should match the name on your tax return.

If this Form W-9 is for a joint account (other than an account maintained by a foreign financial institution (FFI)), list first, and then circle, the name of the person or entity whose number you entered in Part I of Form W-9. If you are providing Form W-9 to an FFI to document a joint account, each holder of the account that is a U.S. person must provide a Form W-9.

a. **Individual.** Generally, enter the name shown on your tax return. If you have changed your last name without informing the Social Security Administration (SSA) of the name change, enter your first name, the last name as shown on your social security card, and your new last name.

Note: ITIN applicant: Enter your individual name as it was entered on your Form W-7 application, line 1a. This should also be the same as the name you entered on the Form 1040/1040A/1040EZ you filed with your application.

b. **Sole proprietor or single-member LLC.** Enter your individual name as shown on your 1040/1040A/1040EZ on line 1. You may enter your business, trade, or "doing business as" (DBA) name on line 2.

c. **Partnership, LLC that is not a single-member LLC, C corporation, or S corporation.** Enter the entity's name as shown on the entity's tax return on line 1 and any business, trade, or DBA name on line 2.

d. **Other entities.** Enter your name as shown on required U.S. federal tax documents on line 1. This name should match the name shown on the charter or other legal document creating the entity. You may enter any business, trade, or DBA name on line 2.

e. **Disregarded entity.** For U.S. federal tax purposes, an entity that is disregarded as an entity separate from its owner is treated as a "disregarded entity." See Regulations section 301.7701-2(c)(2)(iii). Enter the owner's name on line 1. The name of the entity entered on line 1 should never be a disregarded entity. The name on line 1 should be the name shown on the income tax return on which the income should be reported. For example, if a foreign LLC that is treated as a disregarded entity for U.S. federal tax purposes has a single owner that is a U.S. person, the U.S. owner's name is required to be provided on line 1. If the direct owner of the entity is also a disregarded entity, enter the first owner that is not disregarded for federal tax purposes. Enter the disregarded entity's name on line 2, "Business name/disregarded entity name." If the owner of the disregarded entity is a foreign person, the owner must complete an appropriate Form W-8 instead of a Form W-9. This is the case even if the foreign person has a U.S. TIN.

Line 2

If you have a business name, trade name, DBA name, or disregarded entity name, you may enter it on line 2.

Line 3

Check the appropriate box on line 3 for the U.S. federal tax classification of the person whose name is entered on line 1. Check only one box on line 3.

IF the entity/person on line 1 is a(n) . . .	THEN check the box for . . .
• Corporation	Corporation
• Individual • Sole proprietorship, or • Single-member limited liability company (LLC) owned by an individual and disregarded for U.S. federal tax purposes.	Individual/sole proprietor or single-member LLC
• LLC treated as a partnership for U.S. federal tax purposes, • LLC that has filed Form 8832 or 2553 to be taxed as a corporation, or • LLC that is disregarded as an entity separate from its owner but the owner is another LLC that is not disregarded for U.S. federal tax purposes.	Limited liability company and enter the appropriate tax classification. (P= Partnership; C= C corporation; or S= S corporation)
• Partnership	Partnership
• Trust/estate	Trust/estate

Line 4, Exemptions

If you are exempt from backup withholding and/or FATCA reporting, enter in the appropriate space on line 4 any code(s) that may apply to you.

Exempt payee code.

- Generally, individuals (including sole proprietors) are not exempt from backup withholding.
- Except as provided below, corporations are exempt from backup withholding for certain payments, including interest and dividends.
- Corporations are not exempt from backup withholding for payments made in settlement of payment card or third party network transactions.
- Corporations are not exempt from backup withholding with respect to attorneys' fees or gross proceeds paid to attorneys, and corporations that provide medical or health care services are not exempt with respect to payments reportable on Form 1099-MISC.

The following codes identify payees that are exempt from backup withholding. Enter the appropriate code in the space in line 4.

- 1—An organization exempt from tax under section 501(a), any IRA, or a custodial account under section 403(b)(7) if the account satisfies the requirements of section 401(f)(2)
- 2—The United States or any of its agencies or instrumentalities
- 3—A state, the District of Columbia, a U.S. commonwealth or possession, or any of their political subdivisions or instrumentalities
- 4—A foreign government or any of its political subdivisions, agencies, or instrumentalities
- 5—A corporation
- 6—A dealer in securities or commodities required to register in the United States, the District of Columbia, or a U.S. commonwealth or possession
- 7—A futures commission merchant registered with the Commodity Futures Trading Commission
- 8—A real estate investment trust
- 9—An entity registered at all times during the tax year under the Investment Company Act of 1940
- 10—A common trust fund operated by a bank under section 584(a)
- 11—A financial institution
- 12—A middleman known in the investment community as a nominee or custodian
- 13—A trust exempt from tax under section 664 or described in section 4947

The following chart shows types of payments that may be exempt from backup withholding. The chart applies to the exempt payees listed above, 1 through 13.

IF the payment is for . . .	THEN the payment is exempt for . . .
Interest and dividend payments	All exempt payees except for 7
Broker transactions	Exempt payees 1 through 4 and 6 through 11 and all C corporations. S corporations must not enter an exempt payee code because they are exempt only for sales of noncovered securities acquired prior to 2012.
Barter exchange transactions and patronage dividends	Exempt payees 1 through 4
Payments over \$600 required to be reported and direct sales over \$5,000 ¹	Generally, exempt payees 1 through 5 ²
Payments made in settlement of payment card or third party network transactions	Exempt payees 1 through 4

¹ See Form 1099-MISC, Miscellaneous Income, and its instructions.

² However, the following payments made to a corporation and reportable on Form 1099-MISC are not exempt from backup withholding: medical and health care payments, attorneys' fees, gross proceeds paid to an attorney reportable under section 6045(f), and payments for services paid by a federal executive agency.

Exemption from FATCA reporting code. The following codes identify payees that are exempt from reporting under FATCA. These codes apply to persons submitting this form for accounts maintained outside of the United States by certain foreign financial institutions. Therefore, if you are only submitting this form for an account you hold in the United States, you may leave this field blank. Consult with the person requesting this form if you are uncertain if the financial institution is subject to these requirements. A requester may indicate that a code is not required by providing you with a Form W-9 with "Not Applicable" (or any similar indication) written or printed on the line for a FATCA exemption code.

A—An organization exempt from tax under section 501(a) or any individual retirement plan as defined in section 7701(a)(37)

B—The United States or any of its agencies or instrumentalities

C—A state, the District of Columbia, a U.S. commonwealth or possession, or any of their political subdivisions or instrumentalities

D—A corporation the stock of which is regularly traded on one or more established securities markets, as described in Regulations section 1.1472-1(c)(1)(i)

E—A corporation that is a member of the same expanded affiliated group as a corporation described in Regulations section 1.1472-1(c)(1)(i)

F—A dealer in securities, commodities, or derivative financial instruments (including notional principal contracts, futures, forwards, and options) that is registered as such under the laws of the United States or any state

G—A real estate investment trust

H—A regulated investment company as defined in section 851 or an entity registered at all times during the tax year under the Investment Company Act of 1940

I—A common trust fund as defined in section 584(a)

J—A bank as defined in section 581

K—A broker

L—A trust exempt from tax under section 664 or described in section 4947(a)(1)

M—A tax exempt trust under a section 403(b) plan or section 457(g) plan

Note: You may wish to consult with the financial institution requesting this form to determine whether the FATCA code and/or exempt payee code should be completed.

Line 5

Enter your address (number, street, and apartment or suite number). This is where the requester of this Form W-9 will mail your information returns. If this address differs from the one the requester already has on file, write NEW at the top. If a new address is provided, there is still a chance the old address will be used until the payor changes your address in their records.

Line 6

Enter your city, state, and ZIP code.

Part I. Taxpayer Identification Number (TIN)

Enter your TIN in the appropriate box. If you are a resident alien and you do not have and are not eligible to get an SSN, your TIN is your IRS individual taxpayer identification number (ITIN). Enter it in the social security number box. If you do not have an ITIN, see *How to get a TIN* below.

If you are a sole proprietor and you have an EIN, you may enter either your SSN or EIN.

If you are a single-member LLC that is disregarded as an entity separate from its owner, enter the owner's SSN (or EIN, if the owner has one). Do not enter the disregarded entity's EIN. If the LLC is classified as a corporation or partnership, enter the entity's EIN.

Note: See *What Name and Number To Give the Requester*, later, for further clarification of name and TIN combinations.

How to get a TIN. If you do not have a TIN, apply for one immediately. To apply for an SSN, get Form SS-5, Application for a Social Security Card, from your local SSA office or get this form online at www.SSA.gov. You may also get this form by calling 1-800-772-1213. Use Form W-7, Application for IRS Individual Taxpayer Identification Number, to apply for an ITIN, or Form SS-4, Application for Employer Identification Number, to apply for an EIN. You can apply for an EIN online by accessing the IRS website at www.irs.gov/Businesses and clicking on Employer Identification Number (EIN) under Starting a Business. Go to www.irs.gov/Forms to view, download, or print Form W-7 and/or Form SS-4. Or, you can go to www.irs.gov/OrderForms to place an order and have Form W-7 and/or SS-4 mailed to you within 10 business days.

If you are asked to complete Form W-9 but do not have a TIN, apply for a TIN and write "Applied For" in the space for the TIN, sign and date the form, and give it to the requester. For interest and dividend payments, and certain payments made with respect to readily tradable instruments, generally you will have 60 days to get a TIN and give it to the requester before you are subject to backup withholding on payments. The 60-day rule does not apply to other types of payments. You will be subject to backup withholding on all such payments until you provide your TIN to the requester.

Note: Entering "Applied For" means that you have already applied for a TIN or that you intend to apply for one soon.

Caution: A disregarded U.S. entity that has a foreign owner must use the appropriate Form W-8.

Part II. Certification

To establish to the withholding agent that you are a U.S. person, or resident alien, sign Form W-9. You may be requested to sign by the withholding agent even if item 1, 4, or 5 below indicates otherwise.

For a joint account, only the person whose TIN is shown in Part I should sign (when required). In the case of a disregarded entity, the person identified on line 1 must sign. Exempt payees, see *Exempt payee code*, earlier.

Signature requirements. Complete the certification as indicated in items 1 through 5 below.

1. Interest, dividend, and barter exchange accounts opened before 1984 and broker accounts considered active during 1983. You must give your correct TIN, but you do not have to sign the certification.

2. Interest, dividend, broker, and barter exchange accounts opened after 1983 and broker accounts considered inactive during 1983. You must sign the certification or backup withholding will apply. If you are subject to backup withholding and you are merely providing your correct TIN to the requester, you must cross out item 2 in the certification before signing the form.

3. Real estate transactions. You must sign the certification. You may cross out item 2 of the certification.

4. Other payments. You must give your correct TIN, but you do not have to sign the certification unless you have been notified that you have previously given an incorrect TIN. "Other payments" include payments made in the course of the requester's trade or business for rents, royalties, goods (other than bills for merchandise), medical and health care services (including payments to corporations), payments to a nonemployee for services, payments made in settlement of payment card and third party network transactions, payments to certain fishing boat crew members and fishermen, and gross proceeds paid to attorneys (including payments to corporations).

5. Mortgage interest paid by you, acquisition or abandonment of secured property, cancellation of debt, qualified tuition program payments (under section 529), ABLÉ accounts (under section 529A), IRA, Coverdell ESA, Archer MSA or HSA contributions or distributions, and pension distributions. You must give your correct TIN, but you do not have to sign the certification.

What Name and Number To Give the Requester

For this type of account:	Give name and SSN of:
1. Individual	The individual
2. Two or more individuals (joint account) other than an account maintained by an FFI	The actual owner of the account or, if combined funds, the first individual on the account ¹
3. Two or more U.S. persons (joint account maintained by an FFI)	Each holder of the account
4. Custodial account of a minor (Uniform Gift to Minors Act)	The minor ²
5. a. The usual revocable savings trust (grantor is also trustee) b. So-called trust account that is not a legal or valid trust under state law	The grantor-trustee ¹ The actual owner ¹
6. Sole proprietorship or disregarded entity owned by an individual	The owner ³
7. Grantor trust filing under Optional Form 1099 Filing Method 1 (see Regulations section 1.671-4(b)(2)(i)(A))	The grantor ⁴

For this type of account:	Give name and EIN of:
8. Disregarded entity not owned by an individual	The owner
9. A valid trust, estate, or pension trust	Legal entity ⁴
10. Corporation or LLC electing corporate status on Form 8832 or Form 2553	The corporation
11. Association, club, religious, charitable, educational, or other tax-exempt organization	The organization
12. Partnership or multi-member LLC	The partnership
13. A broker or registered nominee	The broker or nominee

For this type of account:	Give name and EIN of:
14. Account with the Department of Agriculture in the name of a public entity (such as a state or local government, school district, or prison) that receives agricultural program payments	The public entity
15. Grantor trust filing under the Form 1041 Filing Method or the Optional Form 1099 Filing Method 2 (see Regulations section 1.671-4(b)(2)(i)(B))	The trust

¹ List first and circle the name of the person whose number you furnish. If only one person on a joint account has an SSN, that person's number must be furnished.

² Circle the minor's name and furnish the minor's SSN.

³ You must show your individual name and you may also enter your business or DBA name on the "Business name/disregarded entity" name line. You may use either your SSN or EIN (if you have one), but the IRS encourages you to use your SSN.

⁴ List first and circle the name of the trust, estate, or pension trust. (Do not furnish the TIN of the personal representative or trustee unless the legal entity itself is not designated in the account title.) Also see *Special rules for partnerships*, earlier.

*Note: The grantor also must provide a Form W-9 to trustee of trust.

Note: If no name is circled when more than one name is listed, the number will be considered to be that of the first name listed.

Secure Your Tax Records From Identity Theft

Identity theft occurs when someone uses your personal information such as your name, SSN, or other identifying information, without your permission, to commit fraud or other crimes. An identity thief may use your SSN to get a job or may file a tax return using your SSN to receive a refund.

To reduce your risk:

- Protect your SSN,
- Ensure your employer is protecting your SSN, and
- Be careful when choosing a tax preparer.

If your tax records are affected by identity theft and you receive a notice from the IRS, respond right away to the name and phone number printed on the IRS notice or letter.

If your tax records are not currently affected by identity theft but you think you are at risk due to a lost or stolen purse or wallet, questionable credit card activity or credit report, contact the IRS Identity Theft Hotline at 1-800-908-4490 or submit Form 14039.

For more information, see Pub. 5027, Identity Theft Information for Taxpayers.

Victims of identity theft who are experiencing economic harm or a systemic problem, or are seeking help in resolving tax problems that have not been resolved through normal channels, may be eligible for Taxpayer Advocate Service (TAS) assistance. You can reach TAS by calling the TAS toll-free case intake line at 1-877-777-4778 or TTY/TDD 1-800-829-4059.

Protect yourself from suspicious emails or phishing schemes. Phishing is the creation and use of email and websites designed to mimic legitimate business emails and websites. The most common act is sending an email to a user falsely claiming to be an established legitimate enterprise in an attempt to scam the user into surrendering private information that will be used for identity theft.

The IRS does not initiate contacts with taxpayers via emails. Also, the IRS does not request personal detailed information through email or ask taxpayers for the PIN numbers, passwords, or similar secret access information for their credit card, bank, or other financial accounts.

If you receive an unsolicited email claiming to be from the IRS, forward this message to phishing@irs.gov. You may also report misuse of the IRS name, logo, or other IRS property to the Treasury Inspector General for Tax Administration (TIGTA) at 1-800-366-4484. You can forward suspicious emails to the Federal Trade Commission at spam@uce.gov or report them at www.ftc.gov/complaint. You can contact the FTC at www.ftc.gov/idtheft or 877-IDTHEFT (877-438-4338). If you have been the victim of identity theft, see www.IdentityTheft.gov and Pub. 5027.

Visit www.irs.gov/IdentityTheft to learn more about identity theft and how to reduce your risk.

Privacy Act Notice

Section 6109 of the Internal Revenue Code requires you to provide your correct TIN to persons (including federal agencies) who are required to file information returns with the IRS to report interest, dividends, or certain other income paid to you; mortgage interest you paid; the acquisition or abandonment of secured property; the cancellation of debt; or contributions you made to an IRA, Archer MSA, or HSA. The person collecting this form uses the information on the form to file information returns with the IRS, reporting the above information. Routine uses of this information include giving it to the Department of Justice for civil and criminal litigation and to cities, states, the District of Columbia, and U.S. commonwealths and possessions for use in administering their laws. The information also may be disclosed to other countries under a treaty, to federal and state agencies to enforce civil and criminal laws, or to federal law enforcement and intelligence agencies to combat terrorism. You must provide your TIN whether or not you are required to file a tax return. Under section 3406, payers must generally withhold a percentage of taxable interest, dividend, and certain other payments to a payee who does not give a TIN to the payer. Certain penalties may also apply for providing false or fraudulent information.

CONSTRUCTION AGREEMENT

COLUMBIA COUNTY, a political subdivision of the State of Florida, by and through its Board of County Commissioners, situated at 135 NE Hernando Avenue, Suite 203, Lake City, Florida 32056- 1529 (the "County"), hereby enters into this Construction Agreement on this ___ day of _____, 2026 with _____ (the "Contractor") of _____ (address) a contractor licensed to perform all work in the State of Florida in connection with the County's Project No. _____ (the "Project"), as said work is set forth in the Plans and Specifications and other Contract Documents hereafter specified (the "Work"). The designee for the Project and the Work, as referenced in this Agreement, shall be

Donald Dupree

The County and the Contractor, for the consideration herein set forth, agree as follows:

Section 1. Contract Documents

The Contract Documents consist of this Agreement, the Exhibits described in Section 4 hereof, the Legal Advertisement, the Instructions to Bidders, the Proposal and any duly executed and issued addenda, Change Orders, Work Directive Changes, Field Orders, Work Authorizations and amendments relating thereto. All of the foregoing Contract Documents are incorporated by reference and made a part of this Agreement (all of said documents including the Agreement sometimes being referred to herein as the "Contract Documents" and sometimes as the "Agreement"). A copy of the Contract Documents shall be maintained by Contractor at the Project site at all times during the performance of the Work.

Section 2. Scope of Work

The Contractor agrees to furnish and pay for all management, supervision, financing, labor, materials, tools, fuel, supplies, utilities, equipment and services of every kind and type necessary to diligently, timely, and fully perform and complete in a good and workmanlike manner the Work required by this Agreement.

Section 3. Contract Amount

In consideration of the faithful performance by the Contractor of the covenants in this Agreement to the full satisfaction and acceptance of the County, the County agrees to pay, or cause to be paid, to Contractor the following amount (herein "Contract Amount"), in accordance with the terms of this Agreement: \$

_____ (_____
_____).

[INSERT SCHEDULE OF UNIT PRICES AS APPLICABLE]

Section 4. Exhibits Incorporated

The following documents are expressly agreed to be incorporated by reference and made a part of this Agreement:

- A. Legal Advertisement
- B. Invitation to Bid
- C. Bid Proposal with required forms
- D. Performance Bond
- E. Public Payment Bond
- F. Insurance Requirements, including certificates of insurance
- G. Form of Release and Affidavit
- H. Change Order Form
- I. Notice of Award
- J. Notice to Proceed Form
- K. Application for Payment Form
- L. Special Conditions, if any
- M. Project Plans**
- N. _____
- O. _____
- P. _____

Section 5. Bonds

A. The Contractor shall provide Performance and Payment Bonds, in the form prescribed in the Exhibits to the Agreement, in the amount of 100% of the Contract Amount, the costs of which are to be paid by Contractor. The Performance and Payment Bonds shall be underwritten by a surety authorized to do business in the State of Florida and otherwise acceptable to the County; provided, however, the surety shall be rated as "A-" or better as to general policy holders rating and Class V or higher rating as to financial size category and the amount required shall not exceed 5% of the reported policy holder's surplus, all as reported in the most current Best Key Rating Guide, published by A.M. Best Company, Inc. of 75 Fulton Street, New York, New York 10038.

B. If the surety for any bond furnished by Contractor is declared bankrupt, becomes insolvent, its right to do business is terminated in the State of Florida, or it ceases to meet the requirements imposed by the Contract Documents, the Contractor shall, within five (5) calendar days thereafter, substitute another bond and surety, both of which shall be subject to the County's approval.

Section 6. Contract Time and Liquidated Damages

A. Time is of the essence in the performance of the Work under this Agreement. The "Commencement Date" shall be established in the Notice to Proceed to be issued by the County. The Contractor shall commence the Work within five (5) calendar days from the Commencement Date. No Work shall be performed at the Project site prior to the Commencement Date. Any Work performed by the Contractor prior to the Commencement Date shall be at the sole risk of the Contractor. The Work shall be substantially completed within _____ calendar days from the

Commencement Date. The date of substantial completion of the Work (or designated portions thereof) is the date certified by the County when construction is sufficiently complete, in accordance with the Contract Documents, so the County can occupy or utilize the Work (or designated portions thereof) for the use for which it is intended. The Work shall be fully completed and ready for final acceptance by the County within 30 calendar days from the Commencement Date (herein "Contract Time").

B. The County and the Contractor recognize that, since time is of the essence for this Agreement, the County will suffer financial loss if the Work is not substantially completed within the time specified above, as said time may be adjusted as provided for herein. Should the Contractor fail to substantially complete the Work within the time period noted above, the County shall be entitled to assess, as liquidated damages, but not as a penalty, _____ for each calendar day thereafter until substantial completion is achieved. The Project shall be deemed to be substantially completed on the date the County issues a Substantial Completion Certificate pursuant to the terms hereof. The Contractor hereby expressly waives and relinquishes any right which it may have to seek to characterize the above noted liquidated damages as a penalty, which the parties agree represents a fair and reasonable estimate of the County's actual damages at the time of contracting if the Contractor fails to substantially complete the Work in a timely manner.

C. When any period of time is referenced by days herein, it shall be computed to exclude the first day and include the last day of such period. If the last day of any such period falls on a Saturday or Sunday or on a day made a legal holiday by the law of the applicable jurisdiction, such day shall be omitted from the computation, and the last day shall become the next succeeding day which is not a Saturday, Sunday or legal holiday.

D. Contracts for more than the simplified acquisition threshold, which is the inflation adjusted amount determined by the Civilian Agency Acquisition Council and the Defense Acquisition Regulations Council (Councils) as authorized by 41 U.S.C. 1908, must address administrative, contractual, or legal remedies in instances where contractors violate or breach contract terms, and provide for such sanctions and penalties as appropriate.

Section 7. Intent of Contract Documents and Contractor Representations

A. It is the intent of the Contract Documents to describe a functionally complete project (or portion thereof) to be constructed in accordance with the Contract Documents. Any work, materials or equipment that may reasonably be inferred from the Contract Documents as being required to produce the intended result shall be supplied whether or not specifically called for. When words which have a well-known technical or trade meaning are used to describe work, materials or equipment, such words shall be interpreted in accordance with that meaning. Reference to standard specifications, manuals or codes of any technical society, organization or association or to the laws or regulations of any governmental authority having jurisdiction over the Project, whether such reference be specific or by implication, shall mean the latest standard specification, manual, code, law or regulation in effect at the time the Work is performed, except as may be otherwise specifically stated herein.

B. If before or during the performance of the Work, Contractor discovers a conflict, error or discrepancy in the Contract Documents, Contractor immediately shall report same to the County in writing and before proceeding with the Work affected thereby shall obtain a written interpretation or clarification from the County. Contractor shall take field measurements and verify field conditions and shall carefully compare such field measurements and conditions and other information known to Contractor with the Contract Documents before commencing any portion of the Work.

C. Drawings are intended to show general arrangements, design and extent of Work and are not intended to serve as shop drawings. Specifications are separated into divisions for convenience of reference only and shall not be interpreted as establishing divisions for the Work, trades, subcontracts, or extent of any part of the Work. In the event of a discrepancy between or among the drawings, specifications or other Contract Document provisions, Contractor shall be required to comply with the provision which is the more restrictive or stringent requirement upon the Contractor, as determined by the County.

D. In order to induce Owner to enter into this Agreement Contractor makes the following representations:

- D.1 Contractor has examined and carefully studied the Contract Documents (including those listed in Section 4) and the other related data identified in the Project Documents including “technical data.”
- D.2 Contractor has visited the site and become familiar with and is satisfied as to the general, local, and site conditions that may affect cost, progress, performance or furnishing of the Work.
- D.3 Contractor is familiar with and is satisfied as to all federal, state, and local Laws and Regulations that may affect cost, progress, performance and furnishing of the Work.
- D.4 Contractor has carefully studied all reports of explorations and tests of subsurface conditions at or contiguous to site and all drawings of physical conditions in or relating to existing surface or subsurface structures at or contiguous to the site. Contractor acknowledges that Owner and County do not assume responsibility for the accuracy or completeness of information and data shown or indicated in the Contract Documents with respect to Underground Facilities at or contiguous to the site. Contractor has obtained and carefully studied (or assumes responsibility for having done so) all such additional supplementary examinations, investigations, explorations, tests, studies, and data concerning conditions (surface, subsurface, and Underground Facilities) at or contiguous to the site or otherwise which may affect cost, progress, performance, or furnishing of the Work or which relate to any aspect of the means, methods, techniques, sequences, and procedures of construction to be employed by Contractor and safety precautions, and

programs incident thereto. Contractor does not consider that any additional examinations, investigations, explorations, tests, studies, or data are necessary for the performance and furnishing of the Work at the Contract Price, within the Contract Times and in accordance with the other terms and conditions of the Contract Documents.

- D.5 Contractor is aware of the general nature of work to be performed by Owner and others at the site that relates to the Work as indicated in the Contract Documents.
- D.6 Contractor has correlated the information known to Contractor, information and observation obtained from visits to the site, reports, and drawings identified in the Contract Documents and all additional examinations, investigations, explorations, tests, studies, and data with the Contract Documents.
- D.7 Contractor has given the County written notice of all conflicts, errors, ambiguities or discrepancies that Contractor has discovered in the Contract Documents and the written resolution thereof by the County is acceptable to Contractor, and the Contract Documents are generally sufficient to indicate and convey understanding of all terms and conditions for performance and furnishing of the Work.

Section 8. Investigation and Utilities

A. Contractor shall have the sole responsibility of satisfying itself concerning the nature and location of the Work and the general and local conditions, and particularly, but without limitation, with respect to the following: those affecting transportation, access, disposal, handling and storage of materials; availability and quality of labor; water and electric power; availability and condition of roads; work area; living facilities; climatic conditions and seasons; physical conditions at the work-site and the project area as a whole; topography and ground surface conditions; nature and quantity of the surface materials to be encountered; subsurface conditions; equipment and facilities needed preliminary to and during performance of the Work; and all other costs associated with such performance. The failure of Contractor to acquaint itself with any applicable conditions shall not relieve Contractor from any of its responsibilities to perform under the Contract Documents, nor shall it be considered the basis for any claim for additional time or compensation.

B. Contractor shall locate all existing roadways, railways, drainage facilities and utility services above, upon, or under the Project site, said roadways, railways, drainage facilities and utilities being referred to in this Sub-Section 8.B. as the "Utilities". Contractor shall contact the owners of all Utilities to determine the necessity for relocating or temporarily interrupting any Utilities during the construction of the Project. Contractor shall schedule and coordinate its Work around any such relocation or temporary service interruption. Contractor shall be responsible for properly shoring, supporting and protecting all Utilities at all times during the course of the Work.

Section 9. Schedule

A. The Contractor, within ten (10) calendar days after receipt of a Notice of Award, shall prepare and submit to the County, for their review and approval, a progress schedule for the Project (herein "Progress Schedule"). The Progress Schedule shall relate to all Work required by the Contract Documents and shall: show the various activities of work in sufficient detail to demonstrate a reasonable and workable plan to complete the Project within the Contract Time; show the order and interdependence of activities and the sequence for accomplishing the Work and describe all activities in sufficient detail so that the County can readily identify the work and measure the progress on of each activity; show each activity with a beginning work date, a duration, and a monetary value; include activities for procurement fabrication, and delivery of materials, plant, and equipment, and review time for shop drawings and submittals; include milestone activities when milestones are required by the Contract Documents; and in a Project with more than one phase, adequately identify each phase and its completion date, and not allow activities to span more than one phase. The Contractor shall also submit a working plan with the Progress Schedule, consisting of a concise written description of the construction plan.

B. The County will return inadequate schedules to the Contractor for corrections and Contractor shall resubmit a corrected schedule within five (5) calendar days from the date of the County's return transmittal. The County will use the accepted Project Schedule as the baseline against which to measure the progress. However, by acceptance of the Project Schedule, the County does not endorse or otherwise certify the validity or accuracy of the activity durations or sequencing of activities.

C. The Progress Schedule shall be updated by the Contractor if there is a significant change in the planned order or duration of an activity or upon the request of the County, which shall not be requested more than [INSERT TIMES] a month. All updates to the Progress Schedule shall be subject to the County's review and approval. The County's review and approval of submitted the Progress Schedule and any required or requested updates shall be a condition precedent to the County's obligation to pay the Contractor.

Section 10. Progress Payments

A. Prior to submitting its first Application for Payment, Contractor shall submit to the County, for their review and approval, a schedule of values based upon the Contract Price, listing the major elements of the Work and the dollar value for each element. After its approval by the County, this schedule of values shall be used as the basis for the Contractor's monthly Applications for Payment. This schedule shall be updated and submitted each month to the County along with a completed and notarized copy of the Application for Payment form.

B. Prior to submitting its first Application for Payment, Contractor shall submit to the County a complete list of all its proposed subcontractors and materialmen. The first Application for Payment shall be submitted no earlier than thirty (30) days after the Commencement Date.

C. If payment is requested on the basis of materials and equipment not incorporated into the Project, but delivered and suitably stored at the site or at another location agreed to by the County in writing, the Application for Payment shall also be accompanied by a bill of sale, invoice or other documentation warranting that the County has received the materials and equipment free and clear of all liens, charges, security interests and encumbrances, together with evidence that the materials and equipment are covered by appropriate property insurance and other arrangements to protect the County's interest therein, all of which shall be subject to the County's satisfaction.

D. Contractor shall submit its monthly Application for Payment to the County on or before the 25th day of each month for work performed during the previous month. Invoices received after the 25th day of each month shall be considered for payment as part of the next month's application. Within ten (10) calendar days after receipt of each Application for Payment, the County shall either:

- D.1 indicate his approval of the requested payment;
- D.2 indicate his approval of only a portion of the requested payment, stating in writing his reasons therefore; or
- D.3 return the Application for Payment to the Contractor indicating, in writing, the reason for refusing to approve payment.

In the event of a total denial and return of the Application for Payment by the County, the Contractor may make the necessary corrections and resubmit the Application for Payment. The County shall, within thirty (30) calendar days after County approval of an Application for Payment, pay the Contractor the amounts so approved. Provided, however, in no event shall the County be obligated to pay any amount greater than that portion of the Application for Payment approved by the County.

E. The County shall retain five percent (5%) of the gross amount of each monthly payment request or five percent (5%) of the portion thereof approved by the County for payment, whichever is less. Such sums shall be accumulated and released to Contractor with final payment.

F. Monthly payments to Contractor shall in no way imply approval or acceptance of Contractor's work.

G. Each Application for Payment shall be accompanied by a Release and Affidavit, in the form attached to this Agreement, showing that all materials, labor, equipment and other bills associated with that portion of the Work for which payment is being requested have been paid in full. The County shall not be required to make payment until and unless these affidavits are furnished by the Contractor.

H. The County reserves the right to issue joint checks to Contractor and its material suppliers, subcontractors, labor unions, equipment suppliers, etc., if, in the County's sole judgment, it is necessary to do so to ensure payment to the above named parties or if above named parties have

filed a notice of nonpayment, lien or intent to lien, stop notice, etc.

Section 11. Payments Withheld

A. The County may decline to approve any Application for Payment, or portions thereof, because of subsequently discovered evidence or subsequent inspections. The County may nullify the whole or any part of any approval for payment previously issued and the County may withhold any payments otherwise due Contractor under this Agreement or any other agreement between the County and Contractor, to such extent as may be necessary in the County's opinion to protect it from loss because of:

- A.1 Defective Work not remedied;
- A.2 Third party claims filed or reasonable evidence indicating probable filing of such claims;
- A.3 Failure of Contractor to make payment properly to subcontractors or for labor, materials or equipment;
- A.4 Reasonable doubt that the Work can be completed for the unpaid balance of the Contract Amount;
- A.5 Reasonable indication that the Work will not be completed within the Contract Time;
- A.6 Unsatisfactory prosecution of the Work by the Contractor;
- A.7 Failure to provide accurate and current "As-Builts"; or
- A.8 Any other material breach of the Contract Documents.

B. If these conditions in Subsection 11.A are not remedied or removed, the County may, after three (3) days written notice, rectify the same at Contractor's expense. The County also may offset against any sums due Contractor the amount of any liquidated or unliquidated obligations of Contractor to the County, whether relating to or arising out of this Agreement or any other agreement between Contractor and the County.

Section 12. Final Payment

A. The County shall make final payment to Contractor within thirty (30) calendar days after the Work is finally inspected and accepted by the County in accordance with Section 25.B. herein, provided that Contractor first, and as an explicit condition precedent to the accrual of Contractor's right to final payment, shall have furnished the County with a properly executed and notarized copy of the Release and Affidavit, as well as, a duly executed copy of the Surety's consent to final payment and such other documentation that may be required by the Contract Documents and

the County.

B. Contractor's acceptance of final payment shall constitute a full waiver of any and all claims by Contractor against the County arising out of this Agreement or otherwise relating to the Project, except those previously made in writing and identified by parties as unsettled at the time of the final Application for Payment. Neither the acceptance of the Work nor payment by the County shall be deemed to be a waiver of the County's right to enforce any obligations of Contractor hereunder or to the recovery of damages for defective Work not discovered by the County at the time of final inspection.

Section 13. Submittals and Substitutions

A. Contractor shall carefully examine the Contract Documents for all requirements for approval of materials to be submitted such as a schedule of values, safety manual, shop drawings, data, test results, schedules and samples. Contractor shall submit all such materials at its own expense and in such form as required by the Contract Documents in sufficient time to prevent any delay in the delivery of such materials and the installation thereof.

B. Whenever materials or equipment are specified or described in the Contract Documents by using the name of a proprietary item or the name of a particular supplier, the naming of the item is intended to establish the type, function and quality required. Unless the name is followed by words indicating that no substitution is permitted, materials or equipment of other suppliers may be accepted by the County if sufficient information is submitted by Contractor to allow the County to determine that the material or equipment proposed is equivalent or better than to that named. Requests for review of substitute items of material and equipment will not be accepted by the County from anyone other than Contractor and all such requests must be submitted by Contractor to the County within thirty (30) calendar days after Notice of Award is received by Contractor.

C. If Contractor wishes to furnish or use a substitute item of material or equipment, Contractor shall make application to the County for acceptance thereof, certifying that the proposed substitute shall perform adequately the functions and achieve the results called for by the general design, be similar and of equal substance to that specified and be suited to the same use as that specified. The application shall state that the evaluation and acceptance of the proposed substitute will not prejudice Contractor's achievement of substantial completion on time, whether or not acceptance of the substitute for use in the Work will require a change in any of the Contract Documents (or in the provisions of any other direct contract with the County for the Project) to adapt the design to the proposed substitute and whether or not incorporation or use of the substitute in

connection with the Work is subject to payment of any license fee or royalty. All variations of the proposed substitute from that specified will be identified in the application and available maintenance, repair and replacement service shall be indicated. The application also shall contain an itemized estimate of all costs that will result, directly or indirectly, from acceptance of such substitute, including costs for redesign and claims of other contractors affected by the resulting change, all of which shall be considered by the County in evaluating the proposed substitute. The County may require Contractor to furnish at Contractor's expense additional data about the proposed substitute.

D. If a specific means, method, technique, sequence or procedure of construction is indicated in or required by the Contract Documents, Contractor may furnish or utilize a substitute means, method, sequence, technique or procedure of construction acceptable to the County, if Contractor submits sufficient information to allow the County to determine that the substitute proposed is equivalent to that indicated or required by the Contract Documents. The procedures for submission to and review by the County shall be the same as those provided herein for substitute materials and equipment.

E. The County shall be allowed a reasonable time within which to evaluate each proposed substitute. The County shall be the sole judge of acceptability, and no substitute will be ordered, installed or utilized without the County's prior written acceptance which shall be evidenced by either a Change Order or an approved Shop Drawing. The County may require Contractor to furnish at Contractor's expense a special performance guarantee or other surety with respect to any substitute.

Section 14. Daily Reports, As-Builts and Meetings

A. Unless waived in writing by the County, Contractor shall complete, maintain, and submit to County on a _____ basis a daily log of the Contractor's work in a format approved by the County. The daily log shall document all activities of Contractor at the Project site including, but not limited to, the following:

- A1. Weather conditions showing the high and low temperatures during work hours, the amount of precipitation received on the Project site, and any other weather conditions which adversely affect the Work;
- A2. Any Conditions which adversely affect the Work;
- A3. The hours of operation by Contractor's and subcontractor's personnel;
- A4. The number of Contractor's and subcontractor's personnel present and working at the Project site, by subcontract and trade;

- A5. All equipment present at the Project site, description of equipment use and designation of time equipment was used (specifically indicating any down time);
- A.6. Description of Work being performed at the Project site;
- A.7. Any unusual or special occurrences at the Project site;
- A.8. Materials received at the Project site;
- A.9. A list of all visitors to the Project site; and
- A.10. Any problems that might impact either the cost or quality of the Work or the time of performance.

The daily log shall not constitute nor take the place of any notice required to be given by Contractor to the County pursuant to the Contract Documents.

B. Contractor shall maintain in a safe place at the Project site one record copy of the Contract Documents, including, but not limited to, all drawings, specifications, addenda, amendments, Change Orders, Work Directive Changes and Field Orders, as well as all written interpretations and clarifications issued by the County, in good order and annotated to show all changes made during construction. The annotated drawings shall be continuously updated by the Contractor throughout the prosecution of the Work to accurately reflect all field changes that are made to adapt the Work to field conditions, changes resulting from Change Orders, Work Directive Changes and Field Orders, and all concealed and buried installations of piping, conduit and utility services. All buried and concealed items, both inside and outside the Project site, shall be accurately located on the annotated drawings as to depth and in relationship to not less than two (2) permanent features (e.g. interior or exterior wall faces). The annotated drawings shall be clean and all changes, corrections and dimensions shall be given in a neat and legible manner in a contrasting color. The "As-Built" record documents, together with all approved samples and a counterpart of all approved shop drawings shall be available to County for reference. Current and accurate "As-Built" record documents shall be submitted with each Application for Payment. Failure to provide current and accurate "As-Built" record drawings shall be reason for rejecting the Application for Payment. Upon completion of the Work and as a condition precedent to Contractor's entitlement to final payment, these "As-Built" record documents, samples and shop drawings shall be delivered to the County by Contractor for the County.

C. Contractor shall keep all records and supporting documentation which concern or relate to the Work hereunder for a minimum of five (5) years from the date of termination of this Agreement or the date the Project is completed, whichever is later. The County, or any duly authorized agents or representatives of the County, shall have the right to audit, inspect and copy all such records and documentation as often as they deem necessary during the period of this Agreement

and during the five (5) year period noted above; provided, however, such activity shall be conducted only during normal business hours.

D. In addition to other requirements provided herein, Contractor shall:

D1. Keep and maintain public records that ordinarily and necessarily would be required by the County in order to perform the Work.

D2. Provide the public with access to public records on the same terms and conditions that the County would provide the records and at a cost that does not exceed the cost provided in this chapter or as otherwise provided by law.

D3. Ensure that public records that are exempt or confidential and exempt from public records disclosure requirements are not disclosed except as authorized by law.

D4. Meet all requirements for retaining public records and transfer, at no cost, to the County all public records in possession of the Contractor upon termination of the Contract and destroy any duplicate public records that are exempt or confidential and exempt from public records disclosure requirements. All records stored electronically must be provided to the County in a format that is compatible with the information technology systems of the County.

D5. If the Contractor does not comply with a public records request, the County may terminate this Contract in accordance with Section 23 hereof.

Section 15. Independent Contractor

Contractor is an independent contractor and shall, at its sole cost and expenses and without increase in the contract price, comply with all laws, rules, ordinances, and regulations of all governing bodies having jurisdiction over the Work. Contractor shall be responsible for securing timely inspections and approvals of its work from all such authorities and as required by the Contract Documents. Contractor shall obtain and pay for all necessary permits and licenses, including business licenses; pay all fees, manufacturer's taxes, sales taxes, use taxes, processing taxes, and all federal and state taxes, insurance and contributions for social security and unemployment or disability insurance, which are measured by wages, salaries, or other remunerations paid to Contractor's employees, whether levied under existing or subsequently enacted laws, rules, or regulations. Contractor shall maintain proof that it has complied with all aspects of the foregoing provision and shall make such proof available for review by the County at County's request.

Section 16. Contractor Performance, Extensions, and No Damages for Delay of Work

A. Contractor shall diligently pursue the completion of the Work and coordinate the Work being done on the Project by its subcontractors and materialmen, as well as coordinating its Work with all work of others at the Project Site, so that its Work or the work of others shall not be delayed or impaired by any act or omission by Contractor. Contractor shall be solely responsible for

all construction means, methods, techniques, sequences, and procedures, as well as coordination of all portions of the Work under the Contract Documents.

B. Should Contractor be obstructed or delayed in the prosecution of or completion of the Work as a result of unforeseeable causes beyond the control of Contractor, and not due to its fault or neglect, including but not restricted to acts of God or of the public enemy, acts of government, fires, floods, epidemics, quarantine regulation, strikes or lockouts, Contractor shall notify the County in writing within forty-eight (48) hours after the commencement of such delay, stating the cause or causes thereof, or be deemed to have waived any right which Contractor may have had to request a time extension.

C. No interruption, interference, inefficiency, suspension or delay in the commencement or progress of the Work from any cause whatever, including those for which the County may be responsible, in whole or in part, shall relieve Contractor of his duty to perform or give rise to any right to damages or additional compensation from the County. Contractor expressly acknowledges and agrees that it shall receive no damages for delay. Contractor's sole remedy, if any, against the County will be the right to seek an extension to the Contract Time; provided, however, the granting of any such time extension shall not be a condition precedent to the aforementioned "No Damage For Delay" provision. This paragraph shall expressly apply to claims for early completion, as well as to claims based on late completion.

Section 17. Changes in the Work

A. The County shall have the right at any time during the progress of the Work to increase or decrease the Work. Promptly after being notified of a change, Contractor shall submit an itemized estimate of any cost or time increases or savings it foresees as a result of the change. Except in an emergency endangering life or property, or as expressly set forth herein, no addition or changes to the Work shall be made except upon written order of the County, and the County shall not be liable to the Contractor for any increased compensation without such written order. No officer, employee or agent of the County is authorized to direct any extra or changed work orally.

B. A Change Order, in the form attached to this Agreement, shall be issued and executed promptly after an agreement is reached between Contractor and the County concerning the requested changes. Contractor shall promptly perform changes authorized by duly executed Change Orders. The Contract Amount and Contract Time shall be adjusted in the Change Order in the manner as the County and Contractor shall mutually agree.

C. If the County and Contractor are unable to agree on a Change Order for the requested change, Contractor shall, nevertheless, promptly perform the change as directed by the County in a written Work Directive Change. In that event, the Contract Amount and Contract Time shall be adjusted as directed by the County. If Contractor disagrees with the County's adjustment determination, Contractor must make a claim pursuant to Section 18 of this Agreement or else be deemed to have waived any claim on this matter it might otherwise have had.

D. In the event a requested change results in an increase to the Contract Amount, the amount of the increase shall be limited to the Contractor's reasonable direct labor and material costs and reasonable actual equipment costs as a result of the change (including allowance for labor burden costs) plus a maximum ten percent (10%) markup for all overhead and profit. In the event such change Work is performed by a Subcontractor, a maximum ten percent (10%) markup for all overhead and profit for all Subcontractors' and sub-subcontractors' direct labor and material costs and actual equipment costs shall be permitted, with a maximum five percent (5%) markup thereon by the Contractor for all of its overhead and profit, for a total maximum markup of fifteen percent (15%). All compensation due Contractor and any Subcontractor or sub-subcontractor for field and home office overhead is included in the markups noted above.

E. The County shall have the right to conduct an audit of Contractor's books and records to verify the accuracy of the Contractor's claim with respect to Contractor's costs associated with any Change Order.

F. The County shall have authority to order minor changes in the Work not involving an adjustment to the Contract Amount or an extension to the Contract Time exceeding his/her authority and not inconsistent with the intent of the Contract Documents. Minor changes approved by the County, whether changes to Work and or Contract Time, cumulatively may not exceed ten percent (10%) of the Work and or Original Contract Time. Such changes may be effected by Field Order or by other written order. Such changes shall be binding on the Contractor.

Section 18. Claims and Disputes

A. A Claim is a demand or assertion by one of the parties seeking an adjustment or interpretation of the terms of the Contract Documents, payment of money, extension of time or other relief with respect to the terms of the Contract Documents. The term "Claim" also includes other disputes and matters in question between the County and Contractor arising out of or relating to the Contract Documents. The responsibility to substantiate a Claim shall rest with the party making the Claim.

B. Claims by the Contractor shall be made in writing to the County within forty-eight (48) hours after the first day of the event giving rise to such Claim or else the Contractor shall be deemed to have waived the Claim. Written supporting data shall be submitted to the County within fifteen (15) calendar days after the occurrence of the event, unless the County grants additional time in writing, or else the Contractor shall be deemed to have waived the Claim. All claims shall be priced in accordance with the provisions of Subsection 17.D. County will render a formal decision on the claim in writing within fifteen (15) calendar days after receipt of the Contractor's Claim. County's written decision will be final and binding upon Contractor and unless Contractor submits a written notice to the County requesting non-binding voluntary mediation within fifteen (15) calendar days of the date of such decisions, then Contractor forever waives and relinquishes any rights to bring any future legal actions or court claims with respect to such Claim.

Non-binding Mediation shall be completed within sixty (60) days from the date of Contractor's timely submission of a written notice requesting non-binding voluntary mediation.

C. The Contractor shall proceed diligently with its performance as directed by the County, regardless of any pending Claim, action, suit or administrative proceeding, unless otherwise agreed to by the County in writing. The County shall continue to make payments in accordance with the Contract Documents during the pendency of any Claim.

Section 19. Indemnification and Insurance

A. To the fullest extent permitted by law, Contractor and its surety covenant and agree to indemnify and hold County harmless of and from any and all claims, losses, demands, causes of action and the like, including but not limited to, attorneys' fees and court costs which may be asserted against County by anyone other than Contractor, resulting from, to the extent of, or occurring in connection with the failure of Contractor or supplier of Contractor to perform all work required within the scope of this agreement in strict accordance with the contract documents.

B. To the full extent permitted by law, Contractor hereby agrees to defend and indemnify, protect and hold harmless County, its agents, employees, servants and sureties (individually the "Indemnified Party" and collectively the "Indemnified Parties") of and from any loss or damage and to reimburse the Indemnified Parties for any and all expenses, including legal fees, expert witness fees and other litigation costs to which the Indemnified Parties may be put because of:

- B.1. the liability for claims and liens for labor performed or materials used or furnished through or under Contractor for the project for which Contractor is liable due to any failure of Contractor to adhere to the terms of this agreement or any of the contract documents;
- B.2. liability to County resulting from Contractor's failure to comply with applicable licensing requirements;
- B.3. any personal injury, loss, damage or death to any person or persons (including employees, officers or agents of County, Contractor and lower tier subcontractors) and any property damage arising out of, result from, or in connection with the performance or non-performance of work required in this contract or by reason of any act, omission, fault or negligence whether active or passive of Contractor whether on the project or proceeding to or from the site, including, without limitation, any personal injury, loss, damage, death or property damage caused (or alleged to be caused) by any negligent or grossly negligent act, error or omission of any person or entity, including any Indemnified Party whether such Indemnified Party's or the person's or

entity's negligence be joint or concurrent however, Contractor shall not be required to indemnify an Indemnified Party for that party's sole negligence; or

- B.4. liability imposed upon County directly or indirectly by Contractor's failure or the failure of any of its employees to comply with any law, ordinance, rule, regulation or requirement, including, but not limited to, any Occupational Safety and Health Administration violations and any penalties, including enhancements, resulting in whole or in part by subcontractor's acts or omissions as well as the Immigration Reform and Control Act of 1986 and all rules and regulations adopted pursuant thereto.

C. To the fullest extent permitted by law, in addition to the express duty to indemnify County when there is any causal connection between Contractor's work and any injury, loss, damage, death or property damage, Contractor expressly undertakes a duty to defend County as a separate duty, independent of and broader than the duty to indemnify. The duty to defend agreed to by Contractor hereby expressly include all costs of litigation, attorney's fees, settlement costs and reasonable expenses in connection with the litigation, whether or not the claims made for loss, injury, damage or property damage are valid or groundless and regardless of whether the defense of County is maintained by the County or assumed by Contractor as long as the claims made could be causally connected to Contractor as reasonable determined by County (claims).

D. The County and Contractor agree the first \$100.00 of the Contract Amount paid by the County to Contractor shall be given as separate consideration for this indemnification and duty to defend, and any other indemnification of the County by Contractor provided for within the Contract Documents, the sufficiency of such separate consideration being acknowledged by Contractor by Contractor's execution of the Agreement. The Contractor's obligation under this provision shall not be limited in any way by the agreed upon contract price as shown in this contract or the Contractor's limit of, or lack of, sufficient insurance protection.

E. Contractor shall obtain and carry, at all times during its performance under the Contract Documents, insurance of the types and in the amounts set forth in the Insurance Requirements attached to this Agreement. All insurance policies shall be from responsible companies duly authorized to do business in the State of Florida and/or responsible risk retention group insurance companies which are registered with the State of Florida. Within fifteen (15) calendar days after Notice of Award is received by Contractor, Contractor shall provide the County with properly executed Certificates of Insurance to evidence Contractor's compliance with the insurance requirements of the Contract Documents. Said Certificates of Insurance shall be on forms approved by the County. The Certificates of Insurance shall be personally, manually signed by the authorized representatives of the insurance company/companies shown on the Certificates of Insurance, with proof that they are authorized representatives thereof. In addition, certified, true and exact copies of all insurance policies required hereunder shall be provided to the County, on a timely basis, when requested by the County.

F. The Certificates of Insurance and required insurance policies shall contain provisions that thirty (30) days prior written notice by registered or certified mail shall be given the County of any cancellation, intent not to renew, or reduction in the policies or coverages, except in the application of the aggregate limits provisions. In the event of a reduction in the aggregate limit of any policy, Contractor shall immediately take steps to have the aggregate limit reinstated to the full extent permitted under such policy.

G. All insurance coverages of the Contractor shall be primary to any insurance or self-insurance program carried by the County applicable to this Project. The acceptance by the County of any Certificate of Insurance does not constitute approval or agreement by the County that the insurance requirements have been satisfied or that the insurance policy shown on the Certificate of Insurance is in compliance with the requirements of the Contract Documents. No work shall commence at the Project site unless and until the required Certificates of Insurance are received by the County.

H. Contractor shall require each of its subcontractors to procure and maintain, until the completion of the subcontractor's work, insurance of the types and to the limits specified in the Insurance Requirements attached to this Agreement, unless such insurance requirements for the subcontractor is expressly waived in writing by the County. All liability insurance policies, other than professional liability, worker's compensation, employer's liability and business auto liability policies, obtained by Contractor to meet the requirements of the Contract Documents shall name the County and Engineer as additional insureds and shall contain severability of interest provisions. If any insurance provided pursuant to the Contract Documents expires prior to the completion of the Work, renewal Certificates of Insurance and, if requested by the County, certified, true copies of the renewal policies, shall be furnished by Contractor within thirty (30) days prior to the date of expiration.

I. Should at any time the Contractor not maintain the insurance coverages required herein, the County may terminate the Agreement or at its sole discretion shall be authorized to purchase such coverages and charge the Contractor for such coverages purchased. The County shall be under no obligation to purchase such insurance, nor shall it be responsible for the coverages purchased or the insurance company or companies used. The decision of the County to purchase such insurance coverages shall in no way be construed to be a waiver of any of its rights under the Contract Documents.

J. Contractor shall submit to the County a copy of all accident reports arising out of any injuries to its employees or those of any firm or individual to whom it may have subcontracted a portion of the Work, or any personal injuries or property damages arising or alleged to have arisen on account of any work by Contractor under the Contract Documents.

Section 20. Compliance with Laws

Contractor agrees to comply, at its own expense, with all federal, state and local laws, codes, statutes, ordinances, rules, regulations and requirements applicable to the Project, including but not

limited to those dealing with taxation, worker's compensation, equal employment and safety. If Contractor observes that the Contract Documents are at variance therewith, it shall promptly notify the County in writing.

Equal Employment Opportunity. Except as otherwise provided under 41 CFR Part 60, all contracts that meet the definition of “federally assisted construction contract” in 41 CFR Part 60-1.3 must include the equal opportunity clause provided under 41 CFR 60-1.4(b), in accordance with Executive Order 11246, “Equal Employment Opportunity” (30 FR 12319, 12935, 3 CFR Part, 1964-1965 Comp., p. 339), as amended by Executive Order 11375, “Amending Executive Order 11246 Relating to Equal Employment Opportunity,” and implementing regulations at 41 CFR part 60, “Office of Federal Contract Compliance Programs, Equal Employment Opportunity, Department of Labor.”

Davis-Bacon Act, as amended (40 U.S.C. 3141-3148). When required by Federal program legislation, all prime construction contracts in excess of \$2,000 awarded by non-Federal entities must include a provision for compliance with the Davis-Bacon Act (40 U.S.C. 3141-3144, and 3146-3148) as supplemented by Department of Labor regulations (29 CFR Part 5, “Labor Standards Provisions Applicable to Contracts Covering Federally Financed and Assisted Construction”). In accordance with the statute, contractors must be required to pay wages to laborers and mechanics at a rate not less than the prevailing wages specified in a wage determination made by the Secretary of Labor. In addition, contractors must be required to pay wages not less than once a week. The non-Federal entity must place a copy of the current prevailing wage determination issued by the Department of Labor in each solicitation. The decision to award a contract or subcontract must be conditioned upon the acceptance of the wage determination. The non-Federal entity must report all suspected or reported violations to the Federal awarding agency. The contracts must also include a provision for compliance with the Copeland “Anti-Kickback” Act (40 U.S.C. 3145), as supplemented by Department of Labor regulations (29 CFR Part 3, “Contractors and Subcontractors on Public Building or Public Work Financed in Whole or in Part by Loans or Grants from the United States”). The Act provides that each contractor or subrecipient must be prohibited from inducing, by any means, any person employed in the construction, completion, or repair of public work, to give up any part of the compensation to which he or she is otherwise entitled. The non-Federal entity must report all suspected or reported violations to the Federal awarding agency.

Section 21. Cleanup and Protections

A. Contractor agrees to keep the Project site clean at all times of debris, rubbish and waste materials arising out of the Work. At the completion of the Work, Contractor shall remove all debris, rubbish and waste materials from and about the Project site, as well as all tools, appliances, construction equipment and machinery and surplus materials, and shall leave the Project site clean and ready for occupancy by the County.

B. Any existing surface or subsurface improvements, including, but not limited to, pavements, curbs, sidewalks, pipes, utilities, footings, structures, trees and shrubbery, not indicated in the Contract Documents to be removed or altered, shall be protected by Contractor from damage during the prosecution of the Work. Any such improvements so damaged shall be restored by Contractor to the condition equal to that existing at the time of Contractor's commencement of the

Work.

Section 22. Assignment

Contractor shall not assign this Agreement or any part thereof, without the prior consent in writing of the County. If Contractor does, with approval, assign this Agreement or any part thereof, it shall require that its assignee be bound to it and to assume toward Contractor all of the obligations and responsibilities that Contractor has assumed toward the County.

Section 23. Permits, Licenses and Taxes

A. Pursuant to Section 218.80, F.S., the County will pay for all County permits and fees, including license fees, permit fees, impact fees or inspection fees applicable to the work. Contractor is not responsible for paying for permits issued by the County wherein the work is to be performed, but is responsible for acquiring all permits. The County may require the Contractor to deliver internal budget transfer documents to applicable County agencies when the Contractor is acquiring permits.

B. All permits, fees and licenses necessary for the prosecution of the Work which are not issued by the County shall be acquired and paid for by the Contractor.

C. Contractor shall pay any and all sales, use, or other taxes, assessments and other similar charges when due, as required by any local, state or federal law, as it pertains to the services provided herein. Contractor further agrees that it shall protect, reimburse, and indemnify the County from and assume all liability for its tax obligations under the terms of this Agreement.

Section 24. Termination for Default

A. Contractor shall be considered in material default of the Agreement and such default shall be considered cause for the County to terminate the Agreement, in whole or in part, as further set forth in this Section, if Contractor: (1) fails to begin the Work under the Contract Documents within the time specified herein; or (2) fails to properly and timely perform the Work as directed by the County or as provided for in the approved Progress Schedule; or (3) performs the Work unsuitably or neglects or refuses to remove materials or to correct or replace such Work as may be rejected as unacceptable or unsuitable; or (4) discontinues the prosecution of the Work; or (5) fails to resume Work which has been suspended within a reasonable time after being notified to do so; or (6) becomes insolvent or is declared bankrupt, or commits any act of bankruptcy; or (7) allows any final judgment to stand against it unsatisfied for more than ten (10) days; or (8) makes an assignment for the benefit of creditors; or (9) fails to obey any applicable codes, laws, ordinances, rules or regulations with respect to the Work; or (10) materially breaches any other provision of the Contract Documents.

B. The County shall notify Contractor in writing of Contractor's default(s). If the County determines that Contractor has not remedied and cured the default(s) within seven (7) calendar days

following receipt by Contractor of said written notice, then the County, at its option, without releasing or waiving its rights and remedies against the Contractor's sureties and without prejudice to any other right or remedy it may be entitled to hereunder or by law, may terminate Contractor's right to proceed under the Agreement, in whole or in part, and take possession of all or any portion of the Work and any materials, tools, equipment, and appliances of Contractor, take assignments of any of Contractor's subcontracts and purchase orders, and complete all or any portion of Contractor's Work by whatever means, method or agency which the County, in its sole discretion, may choose.

C. If the County deems any of the foregoing remedies necessary, Contractor agrees that it shall not be entitled to receive any further payments hereunder until after the Project is completed. All monies expended and all of the costs, losses, damages and extra expenses, including all management, administrative and other overhead and other direct and indirect expenses (including Engineer and attorneys' fees) or damages incurred by the County incident to such completion, shall be deducted from the Contract Amount, and if such expenditures exceed the unpaid balance of the Contract Amount, Contractor agrees to pay promptly to the County on demand the full amount of such excess, including costs of collection, attorney's fees (including appeals) and interest thereon at the maximum legal rate of interest until paid. If the unpaid balance of the Contract Amount exceeds all such costs, expenditures and damages incurred by the County to complete the Work, such excess shall be paid to the Contractor. The amount to be paid to the Contractor or the County, as the case may be, shall be approved by the County, upon application, and this obligation for payment shall survive termination of the Agreement.

D. The liability of Contractor hereunder shall extend to and include the full amount of any and all sums paid, expenses and losses incurred, damages sustained, and obligations assumed by the County in good faith under the belief that such payments or assumptions were necessary or required, in completing the Work and providing labor, materials, equipment, supplies, and other items therefore or re-letting the Work, and in settlement, discharge or compromise of any claims, demands, suits, and judgments pertaining to or arising out of the Work hereunder.

E. If, after notice of termination of Contractor's right to proceed pursuant to this Section, it is determined for any reason that Contractor was not in default, or that its default was excusable, or that the County is not entitled to the remedies against Contractor provided herein, then Contractor's remedies against the County shall be the same as and limited to those afforded Contractor under Section 24 below.

Section 24. Termination for Convenience and Right of Suspension

A. The County shall have the right to terminate this Agreement without cause upon seven (7) calendar days' written notice to Contractor. In the event of such termination for convenience, Contractor's recovery against the County shall be limited to that portion of the Contract Amount earned through the date of termination, together with any retainage withheld and reasonable termination expenses incurred, but Contractor shall not be entitled to any other or further recovery against the County, including, but not limited to, damages or any anticipated profit on portions of the Work not performed.

B. The County shall have the right to suspend all or any portions of the Work upon giving Contractor not less than two (2) calendar days' prior written notice of such suspension. If all or any portion of the Work is so suspended, Contractor's sole and exclusive remedy shall be to seek an extension of time to its schedule in accordance with the procedures set forth in the Contract Documents. In no event shall the Contractor be entitled to any additional compensation or damages. Provided, however, if the ordered suspension exceeds six (6) months, the Contractor shall have the right to terminate the Agreement with respect to that portion of the Work which is subject to the ordered suspension.

C. All contracts in excess of \$10,000 must address termination for cause and for convenience by the non-Federal entity including the manner by which it will be effected and the basis for settlement.

Section 25. Completion

A. When the entire Work (or any portion thereof designated in writing by the County) is ready for its intended use, Contractor shall notify the County in writing that the entire Work (or such designated portion) is substantially complete and request that County issue a Certificate of Substantial Completion (or Certificate of Partial Substantial Completion). Within a reasonable time thereafter, the Contractor and County shall make an inspection of the Work (or designated portion thereof) to determine the status of completion. If the County does not consider the Work (or designated portion) substantially complete, County shall notify Contractor in writing giving the reasons therefor. If the County considers the Work (or designated portion) substantially complete, County shall prepare and deliver to Contractor a Certificate of Substantial Completion (or Certificate of Partial Substantial Completion) which shall fix the date of Substantial Completion for the entire Work (or designated portion thereof) and include a tentative punchlist of items to be completed or corrected by Contractor before final payment. The County shall have the right to exclude Contractor from the Work and Project site (or designated portion thereof) after the date of Substantial Completion, but the County shall allow Contractor reasonable access to complete or correct items on the tentative punchlist.

B. Upon receipt of written certification by Contractor that the Work is completed in accordance with the Contract Documents and is ready for final inspection and acceptance and upon receipt of a final Application for Payment, County will make such inspection and, if he finds the Work acceptable and fully performed under the Contract Documents, he shall promptly issue a final Certificate for Payment, recommending that, on the basis of his observations and inspections, and the Contractor's certification that the Work has been completed in accordance with the terms and conditions of the Contract Documents, that the entire balance found to be due Contractor is due and payable. Neither the final payment nor the retainage shall become due and payable until Contractor submits: (1) the Release and Affidavit in the form attached, (2) consent of surety to final payment, and (3) if required by the County, other data establishing payment or satisfaction of all obligations, such as receipts, releases and waivers of liens, arising out of the Contract Documents, to the extent and in such form as may be designated by the County. The County reserves the right to inspect the

Work and make an independent determination as to the Work's acceptability, even though the County may have issued his recommendations. Unless and until the County is completely satisfied, neither the final payment nor the retainage shall become due and payable.

Section 26. Warranty

Contractor shall obtain and assign to the County all express warranties given to Contractor or any subcontractors by any materialmen supplying materials, equipment or fixtures to be incorporated into the Project. Contractor warrants to the County that any materials and equipment furnished under the Contract Documents shall be new unless otherwise specified, and that all Work shall be of good quality, free from all defects and in conformance with the Contract Documents. Contractor further warrants to the County that all materials and equipment furnished under the Contract Documents shall be applied, installed, connected, erected, used, cleaned and conditioned in accordance with the instructions of the applicable manufacturers, fabricators, suppliers or processors except as otherwise provided for in the Contract Documents. If, within one (1) year after final completion, any Work is found to be defective or not in conformance with the Contract Documents, Contractor shall correct it promptly after receipt of written notice from the County. Contractor shall also be responsible for and pay for replacement or repair of adjacent materials or Work which may be damaged as a result of such replacement or repair. These warranties are in addition to those implied warranties to which the County is entitled as a matter of law.

Section 27. Tests and Inspections.

A. The County, their respective representatives, agents and employees, and governmental agencies with jurisdiction over the Project shall have access at all times to the Work, whether the Work is being performed on or off of the Project site, for their observation, inspection and testing. Contractor shall provide proper, safe conditions for such access. Contractor shall provide the County with timely notice of readiness of the Work for all required inspections, tests or approvals.

B. If the Contract Documents or any codes, laws, ordinances, rules or regulations of any public authority having jurisdiction over the Project requires any portion of the Work to be specifically inspected, tested or approved, Contractor shall assume full responsibility therefore, pay all costs in connection therewith and furnish County the required certificates of inspection, testing or approval. All inspections, tests or approvals shall be performed in a manner and by organizations acceptable to the County.

C. If any Work that is to be inspected, tested or approved is covered without written concurrence from the County, such work must, if requested by County, be uncovered for observation. Such uncovering shall be at Contractor's expense unless Contractor has given County timely notice of Contractor's intention to cover the same and County has not acted with reasonable promptness to respond to such notice. If any Work is covered contrary to written directions from County, such Work must, if requested by County, be uncovered for County's observation and be replaced at Contractor's sole expense.

D. The County shall charge to Contractor and may deduct from any payments due Contractor all engineering and inspection expenses incurred by the County in connection with any overtime work. Such overtime work consisting of any work during the construction period beyond the regular eight (8) hour day and for any work performed on Saturday, Sunday or holidays.

E. Neither observations nor other actions by the County nor inspections, tests or approvals by others shall relieve Contractor from Contractor's obligations to perform the Work in accordance with the Contract Documents.

Section 28. Defective Work

A. Work not conforming to the requirements of the Contract Documents shall be deemed defective Work. If required by the County, Contractor shall, as directed, either correct all defective Work, whether or not fabricated, installed or completed, or if the defective Work has been rejected by the County, remove it from the site and replace it with conforming Work. Contractor shall bear all direct, indirect and consequential costs of such correction or removal (including, but not limited to fees and charges of engineers, architects, attorneys and other professionals) made necessary thereby, and shall hold the County harmless for same.

B. If any portion of the Work is defective, or Contractor fails to supply sufficient skilled workers with suitable materials or equipment, or fails to finish or perform the Work in such a way that the completed Work will conform to the Contract Documents, the County may order Contractor to stop the Work, or any portion thereof, until the cause for such stop in the work has been eliminated; however, this right of the County to stop the Work shall not give rise to any duty on the part of the County to exercise this right for the benefit of Contractor or any other party.

C. If Contractor fails, within a reasonable time after the written notice from the County, to correct defective Work or to remove and replace rejected defective Work as required by the County, or if Contractor fails to perform the Work in accordance with the Contract Documents, or if Contractor fails to comply with any of the provisions of the Contract Documents, the County may, after seven (7) days written notice to Contractor, correct and remedy any such deficiency.

Section 29. Supervision and Superintendents

Contractor shall plan, organize, supervise, schedule, monitor, direct and control the Work competently and efficiently, devoting such attention thereto and applying such skills and expertise as may be necessary to perform the Work in accordance with the Contract Documents. Contractor shall be responsible to see that the finished Work complies accurately with the Contract Documents. Contractor shall keep on the Work at all times during its progress a competent resident superintendent, who shall not be replaced without prior written notice to the County and Engineer except under extraordinary circumstances. The superintendent shall be Contractor's representative at the Project site and shall have authority to act on behalf of Contractor. All communications given to the superintendent shall be as binding as if given to the Contractor.

Section 30. Protection of Work

Contractor shall fully protect the Work from loss or damage and shall bear the cost of any such loss or damage until final payment has been made. If Contractor or any one for whom Contractor is legally liable is responsible for any loss or damage to the Work, or other work or materials of the County or the County's separate contractors, Contractor shall be charged with the same, and any monies necessary to replace such loss or damage shall be deducted from any amounts due Contractor.

Section 31. Emergencies

In the event of an emergency affecting the safety or protection of persons or the Work or property at the Project site or adjacent thereto, Contractor, without special instruction or authorization from the County is obligated to act to prevent threatened damage, injury or loss. Contractor shall give County written notice within forty-eight (48) hours after the occurrence of the emergency, if Contractor believes that any significant changes in the Work or variations from the Contract Documents have been caused thereby. If the County determines that a change in the Contract Documents is required because of the action taken in response to an emergency, a Change Order shall be issued to document the consequences of the changes or variations. If Contractor fails to provide the forty-eight (48) hour written notice noted above, the Contractor shall be deemed to have waived any right it otherwise may have had to seek an adjustment to the Contract Amount or an extension to the Contract Time.

Section 32. Use of Premises

Contractor shall confine all construction equipment, the storage of materials and equipment and the operations of workers to the Project site and land and areas identified in and permitted by the Contract Documents and other lands and areas permitted by law, rights of way, permits and easements, and shall not unreasonably encumber the Project site with construction equipment or other material or equipment. Contractor shall assume full responsibility for any damage to any such land or area, or to the owner or occupant thereof, or any land or areas contiguous thereto, resulting from the performance of the Work.

Section 33. Safety

A. Contractor shall be responsible for initiating, maintaining and supervising all safety precautions and programs in connection with the Work. Contractor shall take all necessary precautions for the safety of, and shall provide the necessary protection to prevent damage, injury or loss to:

- A.1. All employees on the Work and other persons and/or organizations who may be affected thereby;
- A.2. All the Work and materials and equipment to be incorporated therein,

whether in storage on or off the Project site; and

- A.3. Other property on Project site or adjacent thereto, including trees, shrubs, walks, pavements, roadways, structures, utilities and any underground structures or improvements not designated for removal, relocation or replacement in the Contract Documents.

B. Contractor shall comply with all applicable codes, laws, ordinances, rules and regulations of any public body having jurisdiction for the safety of persons or property or to protect them from damage, injury or loss. Contractor shall erect and maintain all necessary safeguards for such safety and protection. Contractor shall notify owners of adjacent property and of underground structures and improvements and utility owners when prosecution of the Work may affect them, and shall cooperate with them in the protection, removal, relocation or replacement of their property. Contractor's duties and responsibilities for the safety and protection of the Work shall continue until such time as the Work is completed and final acceptance of same by the County has occurred.

C. Contractor shall designate a responsible representative at the Project site whose duty shall be the prevention of accidents. This person shall be Contractor's superintendent unless otherwise designated in writing by Contractor to the County.

Section 34. Project Meetings

Prior to the commencement of Work, the Contractor shall attend a preconstruction conference with the Engineer and others as appropriate to discuss the Progress Schedule, procedures for handling shop drawings and other submittals, and for processing Applications for Payment, and to establish a working understanding among the parties as to the Work. During the prosecution of the Work, the Contractor shall attend any and all meetings convened by the County with respect to the Project, when directed to do so by the County. Contractor shall have its subcontractors and suppliers attend all such meetings (including the preconstruction conference) as may be directed by the County.

Section 35. Notices

A. All notices required or made pursuant to this Agreement by the Contractor to the County or Engineer shall be in writing and delivered by hand or by United States Postal Service Department, first class mail, postage pre-paid, return receipt requested, or by Federal Express, addressed to the following:

County

David Kraus, Columbia County Administrator
135 NE Hernando Avenue, Suite 203
Lake City, Florida 32056-1529

With courtesy copies also provided to:

Joel F. Foreman, County Attorney Columbia County, Florida
207 S. Marion Avenue Lake City, Florida 32025

Kevin Kirby, Public Works Director Columbia County, Florida
Post Office Box 969
Lake City, Florida 32056-0969

B. All notices required or made pursuant to this Agreement by the County to Contractor shall be made in writing and shall be delivered by hand or by United States Postal Service Department, first class mail, postage pre-paid, return receipt requested, or by Federal Express, addressed to the following:

Corporate Name of Contractor: _____

Address (including city, state and zip): _____

Name of person with their title and attention the notice should be sent:

Telephone and Fax numbers: _____

Email Address: _____

C. Either party may change its above noted address by giving written notice to the other party in accordance with the requirements of this Section.

Section 36. Modification

No modification or change to the Agreement shall be valid or binding upon the parties unless in writing and executed by the party or parties intended to be bound by it.

Section 37. Successors and Assigns

Subject to other provisions hereof, the Agreement shall be binding upon and shall inure to the benefit of the successors and assigns of the parties to the Agreement.

Section 38. Governing Law

The Agreement shall be interpreted under and its performance governed by the laws of the

State of Florida.

Section 39. Venue

The state courts in and for Columbia County, Florida shall be the proper and sole venue for any legal action on any and all claims, disputes or other matters in controversy arising out of or relating to this Agreement, whether stated as contractual, tort, equitable, statutory or any other claims or causes of action.

Section 40. No Waiver

The failure of the County to enforce at any time or for any period of time any one or more of the provisions of the Agreement shall not be construed to be and shall not be a waiver of any such provision or provisions or of its right thereafter to enforce each and every such provision.

Section 41. Remedies Cumulative

No right or remedy in this Agreement is intended to be exclusive of any other right or remedy, but every such right or remedy shall be cumulative and shall be in addition to and not a limitation of any duties, obligations, rights and remedies otherwise imposed or available by law.

Section 42. Entire Agreement

Each of the parties hereto agrees and represents that the Agreement comprises the full and entire agreement between the parties affecting the Work contemplated, and no other agreement or understanding of any nature concerning the same has been entered into or will be recognized, and that all negotiations, acts, work performed, or payments made prior to the execution hereof shall be deemed merged in, integrated and superseded by the Agreement.

Section 43. Severability

Should any provision of the Agreement be determined by a court to be unenforceable, such a determination shall not affect the validity or enforceability of any other section or part thereof.

Section 44. Third Party Beneficiaries

It is specifically agreed between the parties executing this Agreement that it is not intended by any of the provisions of any part of the Agreement to create in the public or any member thereof, a third party beneficiary under this Agreement, or to authorize anyone not a party to this Agreement to maintain a suit for personal injuries or property damage pursuant to the terms or provisions of this Agreement.

Section 45. Public Records

IF THE CONTRACTOR HAS QUESTIONS REGARDING THE APPLICATION OF CHAPTER 119, FLORIDA STATUTES, TO THE CONTRACTOR'S DUTY TO PROVIDE PUBLIC RECORDS RELATING TO THIS CONTRACT, CONTACT THE CUSTODIAN OF PUBLIC RECORDS at bccadmin@columbiacountyfla.com or call (386) 758-1326 or P.O. Box 1529 Lake City, FL 32056.

Contractor must comply with the public records laws, Florida Statute chapter 119, specifically Contractor must:

- A. Keep and maintain public records required by the County to perform the service.
- B. Upon request from the County's custodian of public records, provide the County with a copy of the requested records or allow the records to be inspected or copied within a reasonable time at a cost that does not exceed the cost provided in chapter 119 Florida Statutes or as otherwise provided by law.
- C. Ensure that public records that are exempt or confidential and exempt from public records disclosure requirements are not disclosed except as authorized by law for the duration of the contract term and following completion of the contract if the contractor does not transfer the records to the County.
- D. Upon completion of the contract, transfer, at no cost, to the County all public records in possession of the contractor or keep and maintain public records required by the County to perform the service. If the contractor transfers all public records to the public agency upon completion of the contract, the contractor shall destroy any duplicate public records that are exempt or confidential and exempt from public records disclosure requirements. If the contractor keeps and maintains public records upon completion of the contract, the contractor shall meet all applicable requirements for retaining the public records. All records stored electronically must be provided to the public agency, upon the request from the public agency's custodian of public records, in a format that is compatible with the information technology systems of the public agency.

IN WITNESS WHEREOF, the parties have executed this Agreement on the date(s) indicated above.

CONTRACTOR: _____
(Company Name)

ATTEST:

By: _____ (Signature) _____ (Printed)

Its: _____ (Title)

Date: _____

Witness:

Its: _____

President/Corporate Secretary/Witness
[Corporate Seal]

Date: _____

2nd Witness (if not incorporated)

OWNER: Board of County Commissioners of Columbia County, Florida

(SEAL)

By: _____
Chairman

Clerk: _____

Date: _____

Approved as to Form and Content:

County Attorney

EXHIBIT A
LEGAL
ADVERTISEMENT

EXHIBIT B
INVITATION TO BID

EXHIBIT C
BID PROPOSAL WITH REQUIRED FORMS

EXHIBIT D
PERFORMANCE BOND

BOND NO. _____

KNOW ALL MEN BY THESE PRESENTS: That _____
_____, as Principal, whose principal business address is
_____ and phone number is _____, and
_____, as Surety, whose principal
address is _____

_____ and phone number is: _____ are
held and firmly bound to Columbia County, Florida (the "COUNTY"), as Obligee in the sum
of: _____

(\$ _____) for the payment whereof we bond ourselves, our heirs, executors,
personal representatives, successors and assigns, jointly and severally.

WHEREAS, Principal has entered into a contract dated as of the _____ day of
_____, 20____, with Obligee for _____

_____ COLUMBIA COUNTY Project
No.: _____ in accordance with drawings and specifications,
which contract is incorporated by reference and made a part hereof, and is referred to as the
Contract.

THE CONDITION OF THIS BOND is that if Principal:

1. Performs the Contract at the times and in the manner prescribed in the Contract; and
2. Pays Obligee any and all losses, damages, costs and attorneys' fees, including appellate proceedings, that Obligee sustains because of any default by Principal under the Contract, including, but not limited to, all delay damages, whether liquidated or actual, incurred by Obligee; and
3. Performs the guarantee of all work and materials furnished under the Contract for the time specified in the Contract, then this bond is void; otherwise it remains in full force.

Any changes in or under the Contract and compliance or noncompliance with any formalities connected with the Contract or the changes do not affect Surety's obligation under this Bond.

The Surety, for value received, hereby stipulates and agrees that no changes, extensions of time, alterations or additions to the terms of the Contract or other work to be performed hereunder, or the specifications referred to therein shall in anywise affect its obligations under this bond, and it does hereby waive notice of any such changes, extensions of time, alterations or additions to the terms of the Contract or to work or to the specifications.

This bond is intended to comply with provisions of Section 255.05, Florida Statutes, and all terms and conditions of said statute are incorporated herein by reference thereto, specifically including but not limited to the notice and time limitation provisions of said section. In the event of any conflict, ambiguity or discrepancy between Section 255.05, Florida Statutes, and this Bond, Florida Statutes shall control. No right of action shall accrue on this Bond to or, for the use of any person or entity other than the COUNTY and those persons or corporations provided for by said statute, their heirs, executors, administrators, successors or assigns.

It is further agreed and understood that if the COUNTY is required to initiate legal proceedings to recover on this Bond, the COUNTY may also recover its costs relating there to, including a reasonable amount for its attorney's fees and legal assistant's fees before trial, at trial, on appeal and in bankruptcy.

IN WITNESS WHEREOF, the above parties have executed this instrument this _____ day of _____, 20____, the name of each party being affixed and these presents duly signed by its undersigned representative, pursuant to authority of its governing body.

Signed, sealed and delivered
in the presence of:

PRINCIPAL: _____
(Company Name of Contractor)

By: _____ (Officers Signature)
_____ (Officers Name Printed)

Witnesses as to Principal Name: _____ (Signature)
Its: _____ (Title)

STATE OF _____

COUNTY OF _____

The foregoing instrument was acknowledged before me this _____ day of _____, 20_____, by _____ (officer's name), as _____ (title) of _____ (company name), a(n) _____ (state) corporation, on behalf of the corporation. He/she is personally known to me OR has produced _____ as identification and did (did not) take an oath.

My Commission Expires: _____

Signature of Notary: _____
(Legibly Printed) _____

(AFFIX OFFICIAL SEAL)

Notary Public, State of _____

Commission No. _____

ATTEST: SURETY:

(Printed Company Name)

(Business Address)

(Surety Authorized Signature)

(Printed Name)

Witness as to Surety _____ (Signature)
_____ (Printed Name)

OR

As Attorney in Fact (Signature)

(Printed Name)

(Attach Power of Attorney)

Witnessed by:

(Signature)

(Printed Name)

(Business Address)

(Telephone Number)

STATE OF _____

COUNTY OF _____

The foregoing instrument was acknowledged before me this _____ day of _____, 20____,
by _____ (officer's name), as _____ (title)
of _____ Surety, on behalf of Surety. He/She is personally
known to me OR has produced _____ as identification and
who did (did not) take an oath.

My Commission Expires: _____

Signature of Notary: _____
(Legibly Printed) _____

(AFFIX OFFICIAL SEAL) Notary Public, State of _____

Commission No. _____

EXHIBIT E
PUBLIC PAYMENT BOND

BOND No. _____

KNOW ALL MEN BY THESE PRESENTS: That _____
_____, as Principal, whose principal business address is:

_____ and phone number and fax numbers are: _____
and _____, as Surety, whose
principal address is:

_____ and phone number and fax numbers are: _____ are held
and firmly bound to COLUMBIA COUNTY, FLORIDA (the "COUNTY") as Obligee in the sum
of _____ (\$ _____)

for the payment whereof we bind ourselves, our heirs, executors, personal representatives,
successors and assigns, jointly and severally.

WHEREAS, Principal has entered into a contract dated as of the ____ day of _____,
20____, with Obligee for _____
in accordance with drawings and specifications, which contract is incorporated by reference and
made a part hereof, and this referred to as the Contract.

THE CONDITION OF THIS BOND is that if Principal promptly makes payment to all
claimants as defined in Section 255.05(1), Florida Statutes, supplying Principal with labor, materials
or supplies, used directly or indirectly by Principal in the prosecution of the work provided for in the
Contract, then this bond is void; otherwise it remains in full force.

Any changes in or under the Contract and compliance or noncompliance with any formalities
connected with the Contract or the changes do not affect Surety's obligation under this Bond.

The provisions of this bond are subject to the time limitations of Section 255.05(2). In no
event will the Surety be liable in the aggregate to claimants for more than the penal sum of this
Payment Bond, regardless of the number of suits that may be filed by claimants.

IN WITNESS WHEREOF, the above parties have executed this instrument this ____ day of
_____, 20____, the name of each party being affixed and these presents duly signed by its
under-signed representative, pursuant to authority of its governing body.

Signed, sealed and delivered in the presence of:

PRINCIPAL: _____
(Company Name of Contractor)

By: _____ (Officer's Signature)
_____ (Officer's Name Printed)

Witnesses as to Principal Name: _____ (Signature)
Its: _____ (Title)

STATE OF _____

COUNTY OF _____

The foregoing instrument was acknowledged before me this ___ day of _____, 20____,
by _____ (officer's name), as
_____ (title) of _____, a
_____ corporation, on behalf of the corporation. He/she is personally known to me OR has
produced _____ as identification and did (did not) take an oath.

My Commission Expires: _____

Signature of Notary: _____

(Legibly Printed) _____

(AFFIX OFFICIAL SEAL)

Notary Public, State of _____

Commission No.: _____

ATTEST: SURETY:

(Printed Company Name)

(Business Address)

(Surety Authorized Signature)

(Printed Name)

Witness as to Surety: _____ (Signature)

OR _____(Printed Name)

As Attorney in Fact (Signature) (Printed Name)

(Attach Power of Attorney)

Witnessed by: _____
(Signature) (Printed Name)

(Business Address)

(Telephone Number)

STATE OF _____
COUNTY OF _____

The foregoing instrument was acknowledged before me this _____ day of_, 20_____, by _____ (officer's name), as _____ (title) of _____ Surety, on behalf of Surety. He/She is personally known to me OR has produced _____ as identification and who did (did not) take an oath.

My Commission Expires: _____

Signature of Notary: _____

(Legibly Printed) _____

(AFFIX OFFICIAL SEAL)

Notary Public, State of _____

Commission No: _____

EXHIBIT F
INSURANCE REQUIREMENTS
CERTIFICATES OF INSURANCE

(1) The Contractor shall obtain and maintain such insurance as will protect it from: (1) claims under worker's compensation laws, disability benefit laws, or other similar employee benefit laws; (2) claims for damages because of bodily injury, occupational sickness or disease or death of his employees including claims insured by usual personal injury liability coverage; (3) claims for damages because of bodily injury, sickness or disease, or death of any person other than his employees including claims insured by usual personal injury liability coverage; and (4) from claims for injury to or destruction of tangible property including loss of use resulting there from -- any or all of which claims may arise out of, or result from, the services, work and operations carried out pursuant to and under the requirements of the Contract Documents, whether such services, work and operations be by the Contractor, its employees, or by subcontractor(s), or anyone employed by or under the supervision of any of them, or for whose acts any of them may be legally liable.

(2) This insurance shall be obtained and written for not less than the limits of liability specified hereinafter, or as required by law, whichever is greater.

(3) The Contractor shall require, and shall be responsible for assuring throughout the time the Agreement is in effect, that any and all of its subcontractors obtain and maintain until the completion of that subcontractor's work, such of the insurance coverages described herein as are required by law to be provided on behalf of their employees and others.

(4) The Contractor shall obtain, have and maintain during the entire period of the Agreement insurance policies, which contain the following information and provisions:

- (A) The name and type of policy and coverages provided;
- (B) The amount or limit applicable to each coverage provided;
- (C) The date of expiration of coverage;
- (D) The designation of the COUNTY as an additional insured and a certificate holder. (This requirement may be exempted for Workers' Compensation and professional liability Insurance.);
- (E) The following clause must appear on the Certificate of Insurance:

Should any material change occur in any of the above described policies or should any of said policies be canceled before the expiration date thereof, the issuing company will mail at least thirty (30) days written notice to the COUNTY.

(5) If the initial, or any subsequently issued Certificate of Insurance expires prior to the completion of the Work or termination of the Agreement, the Contractor shall furnish to the COUNTY, in triplicate, renewal or replacement Certificate(s) of Insurance not later than thirty (30) calendar days prior to the date of their expiration. Failure of the Contractor to provide the COUNTY

with such renewal certificate(s) shall be considered justification for the COUNTY to terminate the Agreement.

(6) Contractor shall include the COUNTY, the COUNTY's agents, officers and employees in the Contractor's General Liability and Automobile Liability policies as additional insureds.

(7) If the COUNTY has any objection to the coverage afforded by other provisions of the insurance required to be purchased and maintained by Contractor in accordance with the requirements of the Contract Documents on the basis of its not complying with the Contract Documents, the COUNTY shall notify Contractor in writing thereof within thirty (30) days of the delivery of such certificates to the COUNTY. Contractor shall provide to the COUNTY such additional information with respect to its insurance as may be requested.

(8) The Contractor shall obtain and maintain the following insurance coverages as provided hereinbefore, and in the type, amounts and in conformance with the following minimum requirements:

WORKERS' COMPENSATION [REVISE AS NEEDED TO MEET COUNTY'S REQUIREMENTS]

State: Statutory
Applicable Federal:
(e.g. Longshoremen's) Statutory
Employer's Liability: \$1,000,000.00

COMPREHENSIVE GENERAL LIABILITY

Bodily Injury: \$1,000,000.00 Each Occurrence
Property Damage: \$1,000,000.00 Each Occurrence

Comprehensive General Liability Insurance shall include:

Contractual Liability, Explosion, Collapse and Underground Coverages and Products and Completed Operations Coverages.

COMPREHENSIVE AUTOMOBILE LIABILITY

Bodily Injury: \$1,000,000.00 Each Occurrence
Property Damage: \$1,000,000.00 Each Occurrence

Comprehensive Automobile Liability shall include coverage for any owned auto, non-owned autos and hired autos.

EXHIBIT G
RELEASE AND AFFIDAVIT

COUNTY OF _____

STATE OF FLORIDA

Before me, the undersigned authority, personally appeared _____
_____, who after being duly sworn, deposes and says:

(1) In accordance with the Contract Documents and in consideration of \$ _____ paid, _____ ("Contractor") releases and waives for itself and its subcontractors, materialmen, s u c c e s s o r s and assigns, all claims demands, damages, costs and expenses, whether in contract or in tort, against Columbia County, Florida (the "COUNTY"), its Board of County Commissioners, employees and agents relating in any way to the performance of the Agreement between Contractor and the COUNTY, dated _____, _____, for the period from _____ to _____.

(2) Contractor certifies for itself and its subcontractors, materialmen, successors and assigns, that all charges for labor, materials, supplies, lands, licenses and other expenses for which the COUNTY might be sued or for which a lien or a demand against any payment bond might be filed, have been fully satisfied and paid.

(3) Contractor agrees to indemnify, defend and save harmless the COUNTY, its Board of County Commissioners, employees and agents from all demands or suits, actions, claims of liens or other charges filed or asserted against the COUNTY arising out of the performance by Contractor of the Work covered by this Release and Affidavit.

(4) This Release and Affidavit is given in connection with Contractor's [monthly/final] Application for Payment No. _____.

CONTRACTOR:

By: _____ (signature of the executive officer)

Its: _____ (title of the executive officer)

Date: _____

Witnesses

[Corporate Seal]

STATE OF _____

COUNTY OF _____

The foregoing instrument was acknowledged before me this _____ day of _____, _____, by _____, as _____ of _____, a _____ corporation, on behalf of the corporation. He/she is personally known to me or has produced _____ as identification and did (did not) take an oath.

My Commission Expires: _____
(Signature of Notary)

Name: _____
(Legibly Printed)

(AFFIX OFFICIAL SEAL)

Notary Public, State of _____

Commission No.: _____

EXHIBIT H
CHANGE ORDER FORM

CHANGE ORDER NO. _____ COLUMBIA COUNTY PROJECT NO. _____

TO: _____

DATE: _____

PROJECT NAME: _____

Columbia County Project No. _____

Under our AGREEMENT dated _____.

You hereby are authorized and directed to make the following change(s) in accordance with terms and conditions of the Agreement:

FOR THE ADDITIVE or DEDUCTIVE Sum of:

_____ (\$ _____).

Original Agreement Amount \$ _____

Sum of Previous Changes \$ _____

This Change Order ADD/DEDUCT \$ _____

Present Agreement Amount \$ _____

The time for completion shall be (increased/decreased) by _____ calendar days due to this Change Order. Accordingly, the Contract Time is now _____ () calendar days and the final completion date is _____. Your acceptance of this Change Order shall constitute a modification to our Agreement and will be performed subject to all the same terms and conditions as contained in our Agreement indicated above, as fully as if the same were repeated in this acceptance. The adjustment, if any, to the Agreement shall constitute a full and final settlement of any and all claims arising out of or related to the change set forth herein, including claims for impact and delay costs.

Accepted: _____, 20 ____.

COLUMBIA COUNTY, FLORIDA

CONTRACTOR

By: _____
Chair

By: _____
President

ENGINEER: By: _____

EXHIBIT I
NOTICE OF AWARD

(This Page is Intentionally Left Blank)

INSERT THE NOTICE OF AWARD BEHIND THIS COVER PAGE

EXHIBIT J

NOTICE TO PROCEED

(This Page is Intentionally Left Blank)

INSERT THE NOTICE TO PROCEED BEHIND THIS COVER PAGE

EXHIBIT K

APPLICATION FOR PAYMENT

(This Page is Intentionally Left Blank)

INSERT THE APPLICATION FOR PAYMENT BEHIND THIS COVER PAGE