

DESIGN SPECIFICATIONS

DESIGN CODE:
2020 FLORIDA BUILDING CODE - RESIDENTIAL
DESIGN IS VOID ONE YEAR AFTER THE DATE OF THE ORIGINAL PLANS, UNLESS PLANS HAVE BEEN REVIEWED FOR CODE COMPLIANCE.

DESIGN LOADS: ACTUAL AND UNIFORM

ROOF LOADING	ROOF	FLOOR
(per 12.2)	(per 12.2)	
TOP CHORD LIVE LOAD	20 psf	40 psf
TOP CHORD DEAD LOAD	7 psf (ARCH SHINGLES)	10 psf
TOP CHORD DEAD LOAD	20 psf (TILE SHINGLES)	10 psf
BOTTOM CHORD LIVE LOAD	10 psf	0 psf
BOTTOM CHORD DEAD LOAD	5 psf	5 psf

DEFLECTION CRITERIA:
ROOF FRAMING: LIVE LOAD L/240 TOTAL LOAD L/180
FLOOR FRAMING: LIVE LOAD L/360 & TOTAL LOAD L/240
0.75" MAX ANY CASE

WIND LOADING:
ASCE 7/16 FOR WIND UPLIFT, TRUSSES SHALL BE DESIGNED WITH A MIN. DEAD LOAD CONDITION OF 5 PSF TOP CHORD, AND 5 PSF BOTTOM CHORD. REACTIONS CALCULATED FOR THE BEARING POINTS OF ROOF TRUSSES SHALL BE REDUCED, SPECIFICALLY, AT THE FLOOR LIVE LOADS COMBINED WITH ROOF LIVE LOADS SHALL BE MULTIPLIED BY 0.75 WHEN COMBINED w/ DEAD LOAD.

BASIC WIND SPEED (ASCE 7-16) 130 MPH
IMPORTANCE FACTOR 1.00
MEAN ROOF HEIGHT 20.0 FT
ROOF PITCH 6/12
BUILDING CATEGORY II
EXPOSURE CATEGORY C
ENCLOSURE CLASSIFICATION - ENCLOSED
INTERNAL PRESSURE COEFFICIENT ± .18

COMPONENTS & CLADDING ALLOWABLE DESIGN PRESSURES

TRIBUTARY AREA (sf)	INTERIOR ZONE (PSF)	EDGE STRIP (PSF): 'a' = 4'-6"	GARAGE DOOR PRESSURES (PSF)
10	+18.24 -19.79	+18.24 -24.42	1 CAR GARAGE DOOR (8'x7')
50	+16.33 -17.88	+16.33 -20.61	2 CAR GARAGE DOOR (16'x7')
100	+15.51 -17.06	+15.51 -18.96	

THE VALUES ABOVE ARE ALLOWABLE WIND PRESSURE VALUES (ASD). THE ABOVE WIND PRESSURES HAVE BEEN REDUCED BY 0.60 AS PERMITTED BY THE ALLOWABLE STRESS DESIGN METHODOLOGY. NO FURTHER REDUCTION SHALL BE PERMITTED.

COMPONENT & CLADDING WALL ELEMENTS SHALL BE DESIGNED FOR BOTH POSITIVE AND NEGATIVE PRESSURES SHOWN IN TABLE ABOVE.

LINEAR INTERPOLATION IS PERMISSIBLE.

PLUS = PRESSURE AND MINUS = SUCTION.

DESIGN OF WINDOWS/DOORS FASTENING TO THE WALL FRAMING IS THE RESPONSIBILITY OF THE WINDOW/DOOR MANUF./SUPPLIER & SHALL MEET THE ABOVE NOTED POSITIVE AND NEGATIVE PRESSURES.

USP CONNECTORS

CONNECTOR	UPLIFT		FASTENERS	FL# CODE
	SYP	SPF		
USP A35	450	450	(9)10dX1 1/2"	
USP RT7	585	495	(5)8d EA. END	
USP RT8A	775	650	(5)10dX1 1/2" EA. END	
USP MTW12	1195	860	(7)10dX1 1/2" EA. END	
USP HTW20	1450	1245	(12)10dX1 1/2" EA. END	
USP MSTA24	1640	1455	(9)10d EA. END	
USP MSTA36	2065	2065	(13)10d EA. END	
USP LTR208	1105	1105	1/2" ROD TO FTG.	
USP JUS28	1305	1305	(6)10d TO HEADER	
USP HTT16	4290	4290	3/4" ROD TO FTG.	
USP HTT22	5370	5370	3/4" ROD TO FTG.	
USP PAU44	2535		3/4" ROD w/ (12)16d	
USP PAU66	2535		3/4" ROD w/ (12)16d	
USP MSTM24	1545	1455	(5)1/2"x2-1/4" TAPCONS	

SIMPSON CONNECTORS

CONNECTOR	UPLIFT		FASTENERS	FL# CODE
	SYP	SPF		
A35	450	450	12-8dX1 1/2"	10446.4
H2.5T	520	520	5-8d EA. END	11478.3
HTS16	1150	1085	16-10d EA. END	10456.6
MTS12	1000	860	7-10dX1 1/2" EA. END	10456.3
HTS20	1450	1245	24-10dX1 1/2" EA. END	13872.3
MSTA24	1765	1270	9-10d EA. END	13872.4
MSTA36	2050	1870	13-10d EA. END	13872.8
HTT4	3480	3080	18-16d TO TRUSS/BAM	11496.2
HTT5	5250	4670	32-16d TO TRUSS/BAM	11496.2
JUS28	930	780	6-10d TO HEADER	10655.113
HU410	905	785	14-16d TO HEADER	10531.36
ABU44	2200		3/4" ROD EPOKID 6" MIN	10849.6
ABU66	2300		3/4" ROD EPOKID 6" MIN	10849.6
SET	N/A	N/A	SIMPSON EPOXY-TIE	11506.4
LT720B	1675	1675	10-16d TO STUD/BAM/POST	11496.3
LSTA12	805	695	10-10d	13872.5
CS16	1705	1705	13-8d	10852.1

MATERIAL SPECIFICATIONS

HARDWARE AND ANCHORS:
ANCHOR BOLTS & THREADED ROD: SHALL BE IN ACCORDANCE WITH ASTM A 307 OR ASTM F 1554 GRADE 36.
WASHERS: SHALL BE IN ACCORDANCE WITH ASTM A500 (GRADE B).
NUTS: SHALL BE IN ACCORDANCE WITH ASTM A 563 GRADE A HEX.
METAL CONNECTORS: ALL METAL CONNECTORS WHICH ARE EXPOSED TO EXTERIOR SHALL BE GALVANIZED.
RETIROFIT REBAR/ROD INSTALLATION: EMBEDMENT OF RODS OR REBAR DOWELS SHALL BE 12 BAR DIAMETER MINIMUM. LAPS SHALL BE 1/4" LARGER THAN REBAR SIX AND 1/2" LARGER THAN THREADED RODS. (U.O.A.)
ANCHORING ADHESIVE: SHALL BE ONE OF THE FOLLOWING PRODUCTS (DUAL CARTRIDGE INSTALLATION ONLY):
EPOXY: T16 RED HEAD A7
REINFORCING STEEL: SHALL BE ASTM A615, GRADE 60.
STRUCTURAL STEEL: SHALL BE ASTM A992, GRADE 50.
WELDED WIRE FABRIC (W/WF): SHALL BE ASTM A655.
LAMINATED VENER LUMBER (LVL): ALL LAMINATED VENER LUMBER SHALL MEET OR EXCEED THE FOLLOWING DESIGN PROPERTIES - ELASTIC MODULUS (E): 1,900ksi, BENDING STRESS (Fb) 2600psi

SCOPE OF SERVICE

MEANS AND METHODS:
THE STRUCTURAL ENGINEER SHALL NOT HAVE CONTROL OR BE RESPONSIBLE FOR CONSTRUCTION MEANS, METHODS, TECHNIQUES, PROCEDURES, OR SEQUENCES, FOR THE ACTS OR OMISSIONS OF THE CONTRACTOR OR ANY OTHER PERSONS PERFORMING THE WORK OR FOR THE FAILURE FOR ANY OF THEM TO CONSTRUCT THE WORK IN ACCORDANCE WITH THE CONTRACT DOCUMENTS.

LIMITS OF STRUCTURAL ENGINEERING DESIGN RESPONSIBILITIES:
THE ITEMS SPECIFICALLY DESIGNED BY THE STRUCTURAL ENGINEER ARE LIMITED TO THE FOLLOWING: CONTINUOUS LOAD PATH FOR WIND UPLIFT, WOOD PANEL SHEARWALLS, WALL FRAMING AND REQUIRED SHEATHING AND HEADERS DIRECTLY SUPPORTING ROOF FRAMING. ITEMS NOT DESIGNED: PRE-ENGINEERED WOOD FLOOR AND ROOF TRUSSES, FLOOR FRAMING NOT SPECIFICALLY ADDRESSED, TRUSS-TO-TRUSS CONNECTION, AND ANY ARCHITECTURAL, MECHANICAL, OR ELECTRICAL SYSTEM.

GENERAL NOTES & CONSTRUCTION SPECIFICATIONS

FLOOR SHEATHING SPECIFICATIONS:
23/32" T&G OSB OR PLYWOOD SHEATHING, GLUE AND NAIL WITH 10d COMMON @ 6" O.C. EDGE & FIELD.

ROOF SHEATHING SPECIFICATIONS:
SINGLE - MIN. 15/32", 32/16, APA RATED OSB OR PLYWOOD SHEATHING, NAILED w/ 0.131x2 1/2" RING SHANK NAILS @ 6" O.C. EDGE & 6" O.C. FIELD (AT GABLE ENDS DECREASE EDGE NAIL SPACING TO 4" O.C. WITHIN 4'-0" OF ROOF EDGE).
TILE - MIN. 15/32" 32/16, APA RATED PLYWOOD SHEATHING, NAILED w/ 0.131x2 1/2" RING SHANK @ 6" O.C. EDGE & 6" O.C. FIELD (AT GABLE ENDS DECREASE EDGE NAIL SPACING TO 4" O.C. WITHIN 4'-0" OF ROOF EDGE).
METAL - MIN. 1/2", 24/16, APA RATED PLYWOOD SHEATHING, NAILED w/ 0.131x2 1/2" RING SHANK NAILS @ 6" O.C. EDGE & 6" O.C. FIELD (AT GABLE ENDS DECREASE EDGE NAIL SPACING TO 4" WITHIN 4'-0" OF ROOF EDGE).

WALL SHEATHING SPECIFICATIONS:
FLEXIBLE FINISH - MIN. 7/8", 24/16, APA RATED OSB OR PLYWOOD SHEATHING, FASTENED w/ 8d @ 6" O.C. EDGE AND 6" O.C. FIELD. SHEATHING SHALL EXTEND FULL HEIGHT FROM BOTTOM PLATE TO UPPER TOP PLATE. FLEXIBLE FINISH WALLS INCLUDE: WOOD, CEMENT, OR VINYL SIDING, HARDI PANEL & BRICK. ALL OTHER WALL SHALL BE CONSIDERED BRITTLE FINISH.
STUCCO FINISH - MIN. 7/8", 24/16, APA RATED OSB OR PLYWOOD SHEATHING, FASTENED w/ 8d @ 6" O.C. EDGE AND 6" O.C. FIELD. SHEATHING SHALL ORIENTED WITH THE LONG DIMENSION PERPENDICULAR TO THE STUDS. CONTRACTOR MAY USE 3/8" STRUCTURAL 1 GRADE SHEATHING OR 3/8" OSB SHEATHING AND ORIENT THE PANELS VERTICALLY.

MASONRY SPECIFICATIONS:
MASONRY HAS BEEN DESIGNED IN ACCORDANCE WITH ACI 530-05, AND SHALL BE CONSTRUCTED IN ACCORDANCE WITH ACI 531-05. GROUT SHALL BE IN ACCORDANCE WITH ASTM C476 WITH A MINIMUM OF 28 DAY COMPRESSIVE STRENGTH OF 2000 PSI PER ASTM C1019. GROUT SHALL HAVE A MAXIMUM COURSE AGGREGATE SIZE OF 3/8" PLACED AT AN 8" TO 11" SLUMP. MORTAR SHALL CONFORM TO ASTM C270 AND TYPE M OR S. TYPE N MORTAR MAY BE USED IN BRICK VENEER. CONTRACTOR SHALL BE RESPONSIBLE FOR THE DESIGN AND INSTALLATION OF ALL FLASHING.

CONCRETE MASONRY UNITS (CMU):
CMU SHALL BE IN ACCORDANCE WITH ASTM C90-75, HOLLOW LOAD-BEARING (CMU), TYPE 1, GRADE N-1, NORMAL WEIGHT, WITH A MINIMUM COMPRESSIVE STRENGTH OF 1900 PSI (f'm=1500 psi). GROUT ALL CELLS CONTAINING VERTICAL REINFORCEMENT IN 5'-0" MAXIMUM LIFTS PROVIDE CLEANOUTS PER ACI 530.1-02 IN THE BOTTOM OF COURSE OF MASONRY WHEN THE WALL HEIGHT EXCEEDS 5'-0".

MASONRY STEM WALLS: ALL CONCRETE MASONRY UNITS SHALL BE COMPOSED OF ASTM C90E, E GRADE N-1 HOLLOW CONCRETE MASONRY UNITS WITH TYPE "S" MORTAR. WALL COURSING SHALL BE RUNNING BONDS, STACK BOND SHALL NOT BE USED. GROUT ALL CELLS CONTAINING VERTICAL REINFORCEMENT WITH 3000 PSI FEA ROCK CONCRETE GROUT. SPLICES IN REINFORCING, WHERE PERMITTED, SHALL BE 48 BAR DIAMETERS. ALL EXTERIOR WALLS SHALL BE REINFORCED FULL HEIGHT WITH #4 @ 4'-0" O.C. MAX. AND AT EACH CORNER, WALL END, AND WALL INTERSECTIONS PROVIDE CONTINUITY OF PERPENDICULAR MASONRY ELEMENTS BY INSTALLING CORNER BARS, MINIMUM OF 40 BAR DIAMETERS INTO EACH ELEMENT. AT STEM WALL CONSTRUCTED OF 5 OR MORE COURSES, PROVIDE HORIZONTAL JOINT REINFORCEMENT AT 16" O.C. VERTICALLY, (EVERY OTHER COURSE), AND VERTICAL REINFORCING SHALL BE INCREASED AS NOTED ON 1/S1.0. UNLESS NOTED OTHERWISE, LAP JOINT REINFORCING SHALL BE A MINIMUM OF 6".

CONCRETE SPECIFICATIONS:
ALL CONCRETE HAS BEEN DESIGNED IN ACCORDANCE WITH ACI 318-08, AND SHALL BE CONSTRUCTED IN ACCORDANCE WITH ACI 301. ALL CONCRETE SHALL HAVE A MINIMUM COMPRESSIVE STRENGTH OF 3000 PSI AT 28 DAYS. CONCRETE AT GARAGE AND PORCH SLABS SHALL HAVE A COMPRESSIVE STRENGTH OF 3000 PSI.

GENERAL NOTES:
FOOTING AND FOUNDATIONS: FOOTINGS AND FOUNDATION SHALL BE IN ACCORDANCE WITH LOCAL BUILDING CODES. FOOTING HAVE BEEN DESIGNED WITH A SOIL BEARING (DESIGN MAXIMUM) OF 2000 PSF. A SOILS INVESTIGATION REPORT IS RECOMMENDED TO VERIFY SUITABLE SUBSURFACE CONDITIONS. IF THE FOOTING ELEVATIONS SHOWN OCCUR IN A DISTURBED OR UNSTABLE SOIL, THE ENGINEER SHALL BE NOTIFIED. SOIL SHALL BE FREE OF ORGANIC MATERIAL AND COHESIVE (CLAY) SOILS. SOIL COMPACTION AND FILL SHALL BE COMPACTED TO A MIN. OF 95% MODIFIED PROCTOR IN ACCORDANCE WITH ASTM D 1557.
FOUNDATION PLAN ONLY CONVEYS STRUCTURAL INFORMATION, FOR GENERAL FEATURES, CONDUITS, ELECTRICAL EMBES, STEP HEIGHTS, ETC., SEE ARCHITECTURAL PLANS. DO NOT SCALE FOOTING DIMENSIONS AND LOCATION FROM THE FOUNDATION PLAN SHOWN ON S1.0. DO NOT DETERMINE FOOTING LOCATION BASED ON EITHER THE ARCHITECTURAL PLAN OR FRAMING PLAN, BUT BY DIMENSIONS PROVIDED ON FOUNDATION PLAN. IF FOOTING SIZE OR LOCATION IS NOT DETERMINED ON PLAN THEN CONTACT ENGINEER OF RECORD (EOR).
UNLESS OTHERWISE NOTED ON DRAWINGS, MINIMUM CONCRETE COVER FOR REINFORCING SHALL BE 3" IN FOOTINGS AND MESH SHALL BE CENTERED IN SLAB ON GRADE. IN ALL CONTINUOUS FOOTINGS PROVIDE #3 @ 48" O.C. OR ROD CHAIRS. PROVIDE CONTINUITY OF REINFORCING AT INTERSECTIONS OF PERPENDICULAR CONCRETE ELEMENTS BY INSTALLING CORNER BARS, MINIMUM OF 40 BAR DIAMETERS INTO EACH ELEMENT. SPLICES IN REINFORCING, WHERE PERMITTED, SHALL BE 48 BAR DIAMETERS.

CONCRETE SLABS ON GRADE:
SHALL BE INSTALLED OVER MINIMUM 6 MIL POLYETHYLENE VAPOR RETARDER WITH JOINTS LAPPED 6" AND SEALED OVER CLEAN, COMPACTED EARTH OR FILL WITH APPROVED CHEMICAL SOIL TREATMENT FOR PREVENTION OF SUBTERRANEAN TERMITES. SAWCUTS FOR CONTROLLED CRACKING CUT A 1" SAWCUT INTO SLAB IN A 12"x12" GRID WITHIN 12 HOURS OF CONCRETE PLACEMENT, PROVIDE SAWCUTS THROUGH OUT SLAB CALL EOR FOR ALTERNATIVE METHODS.

WOOD FRAMING SPECIFICATIONS:
ALL WOOD FRAMING HAS BEEN DESIGNED IN ACCORDANCE WITH NATIONAL DESIGN SPECIFICATIONS (NDS) FOR WOOD CONSTRUCTION, LATEST EDITION. ALL WOOD MEMBERS EXPOSED TO WEATHER OR IN CONTACT WITH MASONRY, CONCRETE OR SOIL SHALL BE PRESURE-TREATED TO ACQ OR NON-DOT BORUATE PRESERVATIVE TREATMENT IS USED, ALL ATTACHED FASTENERS SHALL BE HOT DIPPED GALVANIZED. IF AZCA PRESERVATIVE IS USED, ALL ATTACHED FASTENERS SHALL BE STAINLESS STEEL.

PRE-ENGINEERED WOOD TRUSSES:
SHALL BE THE DESIGN OF AN ENGINEER IN THE STATE WHERE PROJECT IS BEING BUILT AND SHALL COMPLY WITH NPFA, TPI, AND AITC 100. CONTRACTOR SHALL VERIFY THAT ADEQUATE TRUSS BEARING IS INSTALLED AT ALL TRUSSES AS INDICATED IN THE TRUSS SHOP DRAWINGS. ALL TRUSS-TO-TRUSS CONNECTIONS AND TRUSS PROFILES ARE THE RESPONSIBILITY OF THE DELEGATED TRUSS ENGINEER. ALL TRUSSES SHALL HAVE TEMPORARY BRACING PER 'COMMENTARY' AND RECOMMENDATION FOR HANDLING, INSTALLING & BRACING METAL PLATE CONNECTED WOOD TRUSSES, HIB-91." AT MULTIPLE STRAP CONNECTIONS, SPREAD STRAPS TO AVOID NAILING CONFLICTS THROUGH TRUSS. WHEN USING (2) STRAPS ON SINGLE PLY TRUSSES, PLACE STRAPS DIAGONALLY ACROSS DBL. TOP PLATE FROM EA. OTHER.

ROOF COVERING SPECIFICATIONS:
THE CONTRACTOR SHALL BE RESPONSIBLE FOR THE DESIGN AND INSTALLATION OF THE ROOF COVERING SYSTEM. ASPHALT SHINGS SHALL COMPLY WITH ASTM D3161 AND BE INSTALLED ACCORDING TO THE MANUFACTURER'S REQUIREMENTS. CLAY AND TILE ROOFS SHALL BE INSTALLED PER THE "CONCRETE AND CLAY ROOF TILE INSTALLATION MANUAL" AND THE MANUFACTURER'S REQUIREMENTS. STANDING SEAM METAL ROOFS SHALL COMPLY WITH ASTM E1514 AND BE INSTALLED ACCORDING TO THE MANUFACTURER'S REQUIREMENTS. THE CONTRACTOR SHALL BE RESPONSIBLE FOR THE DESIGN AND INSTALLATION OF ALL METAL FLASHING AND VALLEY MATERIALS.

WATERPROOFING:
THE CONTRACTOR SHALL BE RESPONSIBLE FOR THE DESIGN/INSTALLATION OF ALL WATER PROOFING.

WOOD FASTENING SCHEDULE

MEMBERS	CONNECTION TYPE	FASTENER
TOP PLATE TO TOP PLATE	FACE NAIL	2-GUN NAILS @ 12" STAG.
TOP PLATE, LAPS/INTERSECTION	FACE NAIL	(2-16d) 3-GUN NAILS
DBL. TOP PLATE TO STUD	FACE NAIL	(2-16d) 3-GUN NAILS
RIM JOIST TO TOP PLATE	TOE NAIL	(8d @ 6") GUN NAIL @ 6"
CEILING JOIST TO TOP PLATE	TOE NAIL	(3-8d) 5-GUN NAILS
CEILING JOIST, OVER PARTITIONS	FACE NAIL	(3-16d) 4-GUN NAILS
CEILING JOIST TO ROOF RAFTER	FACE NAIL	(6-16d) 8-GUN NAILS
JOIST/TRUSS TO PLATE	TOE NAIL	(2-16d) 3-GUN NAILS
RAFTER TO PLATE	TOE NAIL	(3-8d) 3-GUN NAILS
JACK RAFTER TO HIP	TOE NAIL	(3-10d) 4-GUN NAILS
ROOF RAFTER TO 2x... RIDGE BM.	TOE NAIL	(2-16d) 3-GUN NAILS
CONT. HEADER, TWO PIECES	FACE NAIL	16d @ 16" O.C. @ EDGE
CONT. HEADER TO STUD	TOE NAIL	(3-16d) 4-GUN NAILS
STUD TO SOLE PLATE	TOE NAIL	(3-16d) 4-GUN NAILS
SOLE PLATE TO JOIST/BLOCKING	FACE NAIL	(16d @ 16") GUN NAIL @ 8"

NAIL SPECIFICATIONS

3"x0.131" = GUN NAILS	2"x0.113" = RINK SHANK
2"x0.113" = 6d	2 1/2"x0.131" = 8d
3"x0.148" = 10d	3 1/2"x0.162" = 16d
1 1/2"x0.148" = 10dX1 1/2"	1 1/2"x0.131" = 8dX1 1/2"

BRICK NOTES / LINTEL SCHED

LINTEL DIMENSION	MIN. BRG.	MAX. SPAN
L3 1/2 x 3 1/2 x 1/4	4"	6'-0"
L4 x 3 1/2 x 1/4	6"	8'-0"
L5 x 3 1/2 x 1/4	6"	10'-0"
L6 x 3 1/2 x 1/4	6"	12'-0"
L7 x 3 1/2 x 1/4	6"	16'-0"

1. STEEL LINTELS TO BE MINIMUM 3/8" LINTEL MUST HAVE CORROSION RESISTANT COATING OF EPOXY BASED PAINT.

2. LINTEL MORE THAN 8'-0", SHOULD BE LATERALLY SUPPORTED NOT TO EXCEED 6 FT. O.C. w/ 2-1/4"x5" WD. SCREWS INTO HEADER PROVIDE A 1/2" VERTICAL SLOTTED HOLE FOR SCREW.

3. BRICK VENEER ATTACHMENT, HORIZONTAL TIES @ 24" O.C., VERT. TIES @ 12" O.C. (FOR 10" HIGH WIND-ZONE VERT. TIES @ 16" O.C.). AT ALL OPENINGS SPACE TIES WITHIN 12" OF OPENINGS. PROVIDE 1/4" WEEP HOLES @ 33" O.C. IMMEDIATELY ABOVE FLASHING.

SECTION VIEW OF BRICK LINTEL

PLAN LEGEND AND ABBREVIATIONS

INTERIOR LOAD BEARING WALL	BUILT-UP POST IN THE WALL
GABLE X-BRACE, SEE DETAIL 10/20/01	HEADER SIZE, JACK AND KING STUD QUANTITY
DESIGNATES SHEARWALL, THE HIDDEN LINE DESIGNATES SIDE OF WALL THE SHEARWALL SHEATHING TO BE APPLIED. 8d @ 3/8" SPACES BR COMMONS @ 3" O.C. EDGE & 6" O.C. "IN THE FIELD"	
ADJ - ADJACENT	LG - LONG MANUF
BM - BEAM	MONO - MONOLITHIC
BOT - BOTTOM	OC - ON CENTER
BRG - BEARING	OSB - ORIENTED STRAND BOARD
CMU - CONCRETE MASONRY UNIT	PERP - PERPENDICULAR
DBL - DOUBLE	PRE ENG - PRE ENGINEERED
EA - EACH	PSF - POUNDS PER SQUARE FOOT
EE - EACH END	EQ - EQUAL
EOR - ENGINEER OF RECORD	EQ - EQUAL
EXT - EXTERIOR	REIN - REINFORCE
FBC - FLORIDA BUILDING CODE	SF - SQUARE FOOT
FDN - FOUNDATION	SIP - SPRUCE PINE FUR
FT - FOOT	SYP - SOUTHERN YELLOW PINE
FTD - FOOTING	TYP - TYPICAL
HDR - HEADER	UNP - UNLESS OTHERWISE NOTED
HORIZ - HORIZONTAL	VERT - VERTICAL
LBS - POUNDS	W/F - WELDED WIRE FABRIC

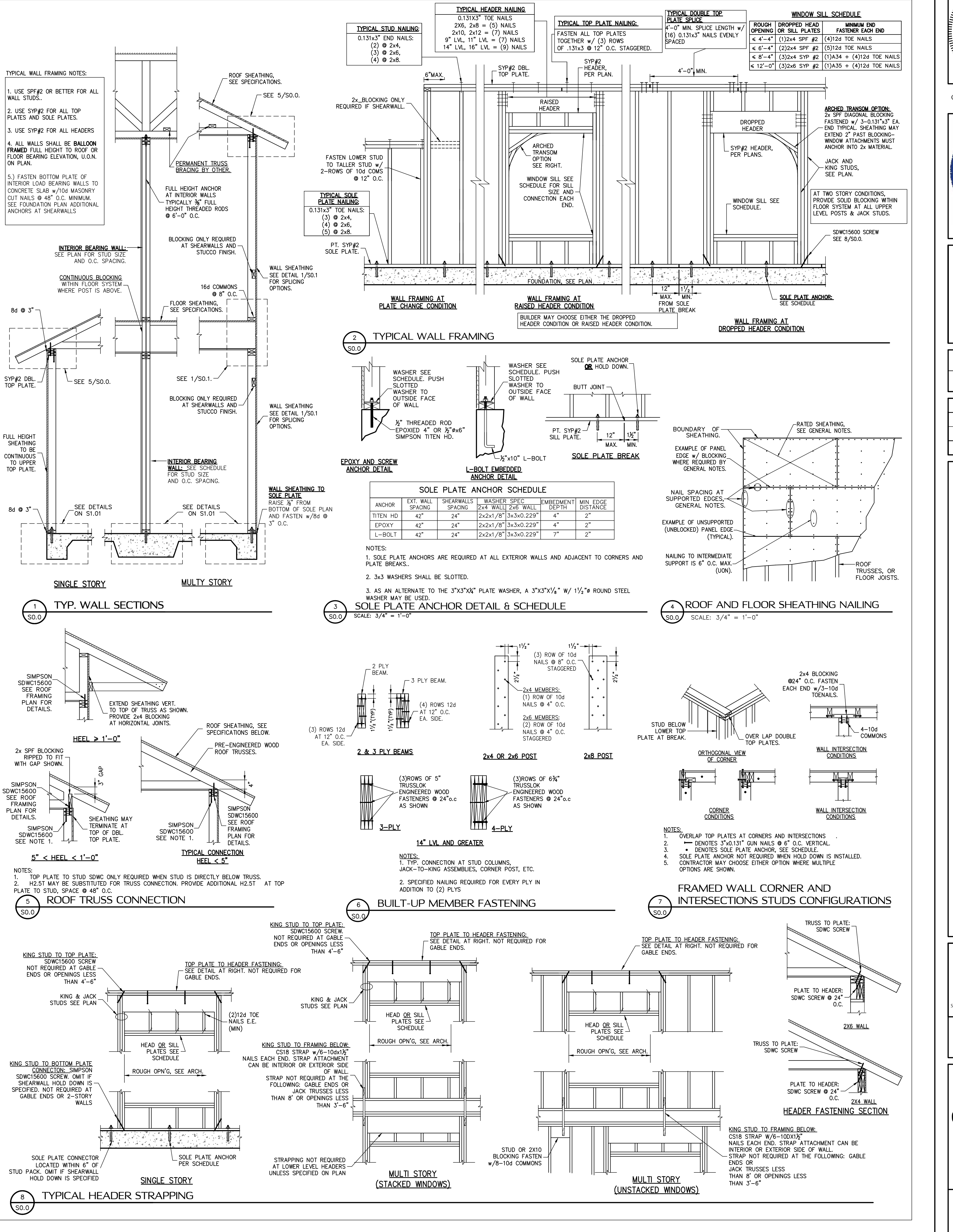

CHRISTOPHER J. SABOURIN
LICENSE # 17461
STATE OF FLORIDA
PROFESSIONAL ENGINEER

Christopher J. Sabourin
FL PE#71461

Columbia County Building Department
Plans Reviewed for Code Compliance
State of Florida

SABO STRUCTURAL ENGINEERING
CA#32529
235 9TH AVE N
JAX BEACH, FL 32250
904-712-5750
CHRIS@SABOENG.COM

ISSUE	DATE
PERMIT	08.01.23
REVISIONS	DATE

PLANN NAME
BZEC MCKINZEY
55E NO.
23-0385

STRUCTURAL ENGINEERING FOR MCKINZEY RESIDENCE

FIELD ALTERATION
CONTRACTOR SHALL CONTACT SABO STRUCTURAL ENGINEERING PRIOR TO MAKING ANY STRUCTURAL FIELD MODIFICATIONS WHICH MAY VARY FROM THE INTENT OF THE ORIGINAL CONSTRUCTION DOCUMENTS. ANY FIELD ALTERATIONS MADE PRIOR TO BEING APPROVED BY CHRISTOPHER J. SABOURIN MAY RESULT IN ADDITIONAL ENGINEERING OR INSPECTION FEES.

SCALING
DO NOT SCALE DIMENSIONS FROM THESE DRAWINGS. IF A DIMENSION IS UNCLEAR REFER TO THE ARCHITECTURAL DRAWINGS OR CONTACT THE E.O.R.

DESIGN CRITERIA AND GENERAL NOTES

SHEET 1 OF 7

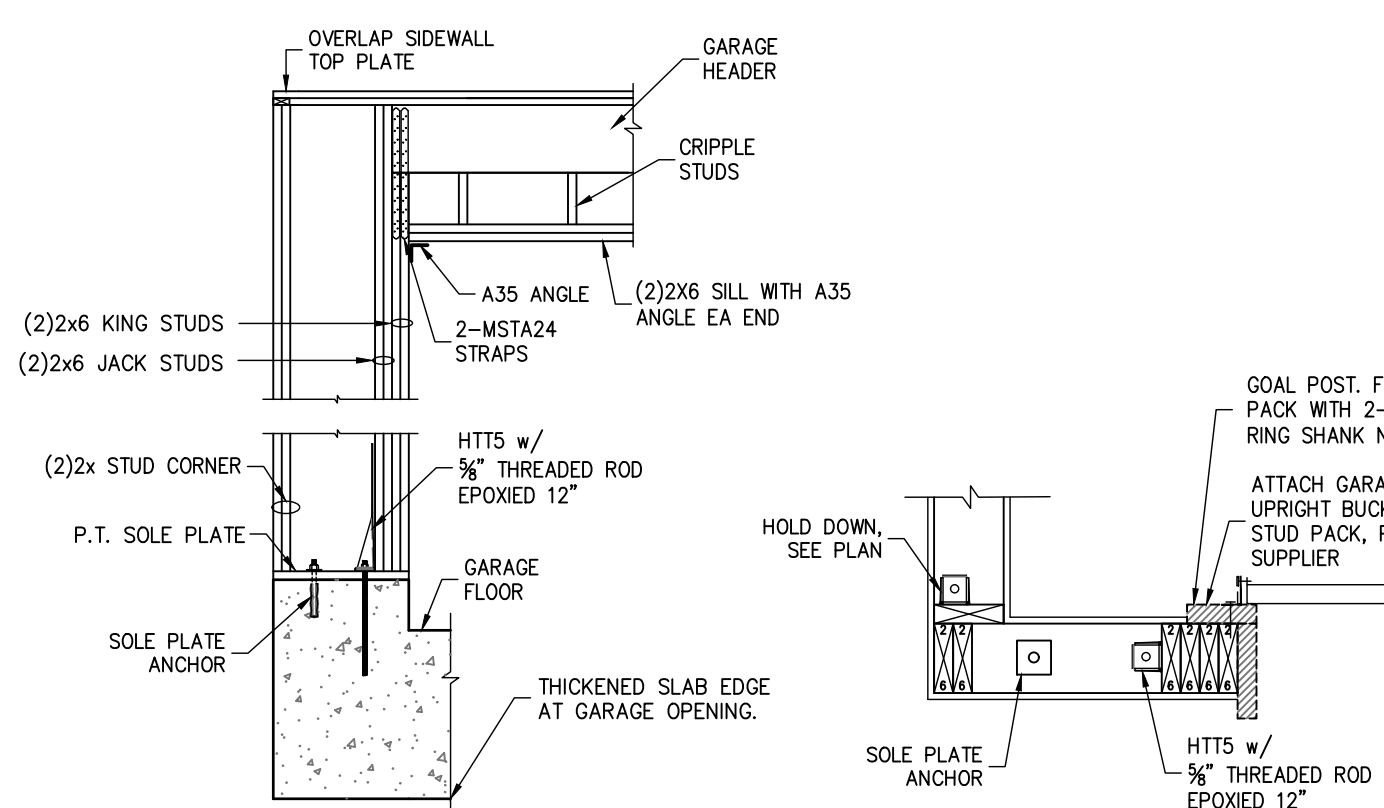

1 GARAGE WING WALL FRAMING
 SO.1 THIS DETAIL ONLY APPLIES WHEN NOTED ON PLAN

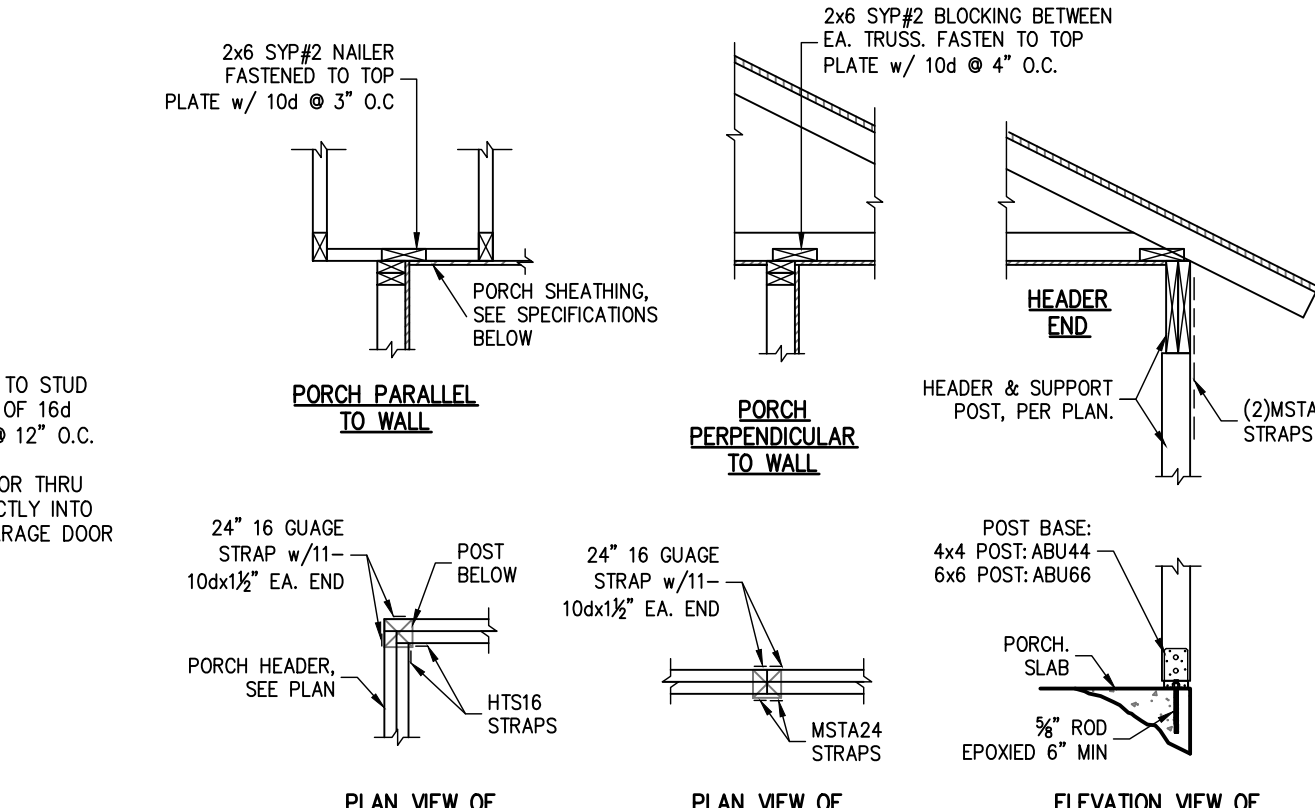

2 TYPICAL PORCH FRAMING DETAILS
 SO.1 SCALE: N.T.S.

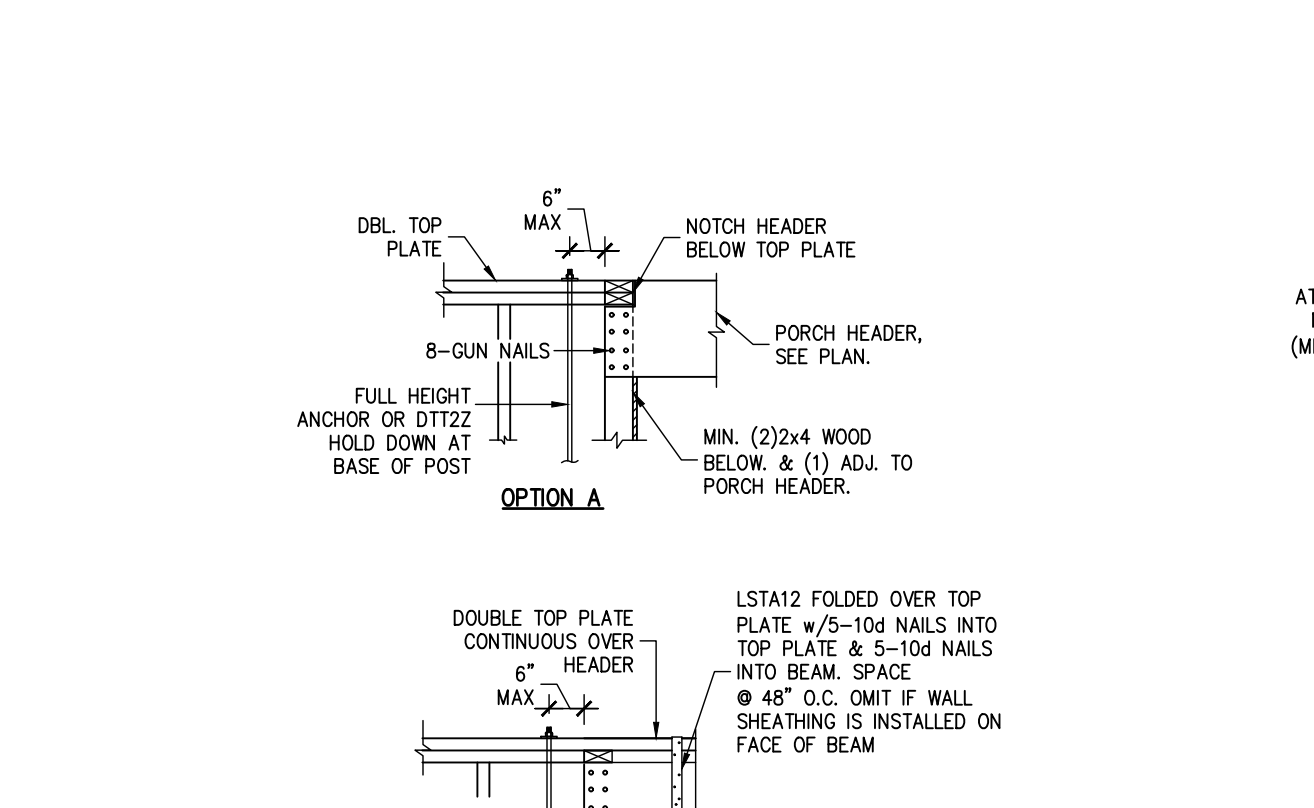

3 TYPICAL PORCH BEAM CONNECTION
 SO.1 SCALE: N.T.S.

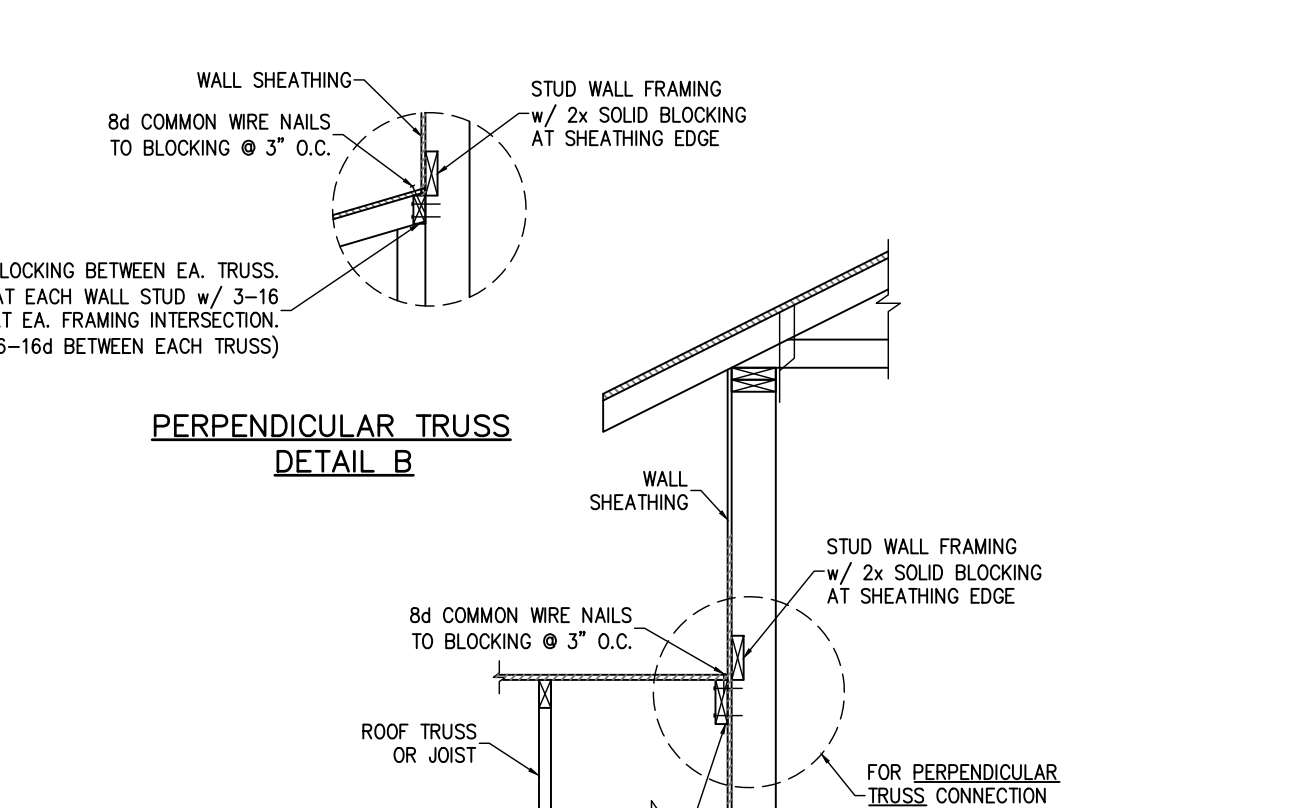

4 WALL ADJ. TO ROOF CONNECTION
 SO.1 SEE CONSTRUCTION SPECIFICATIONS FOR ROOF AND WALL SHEATHING AND STUD FRAMING.

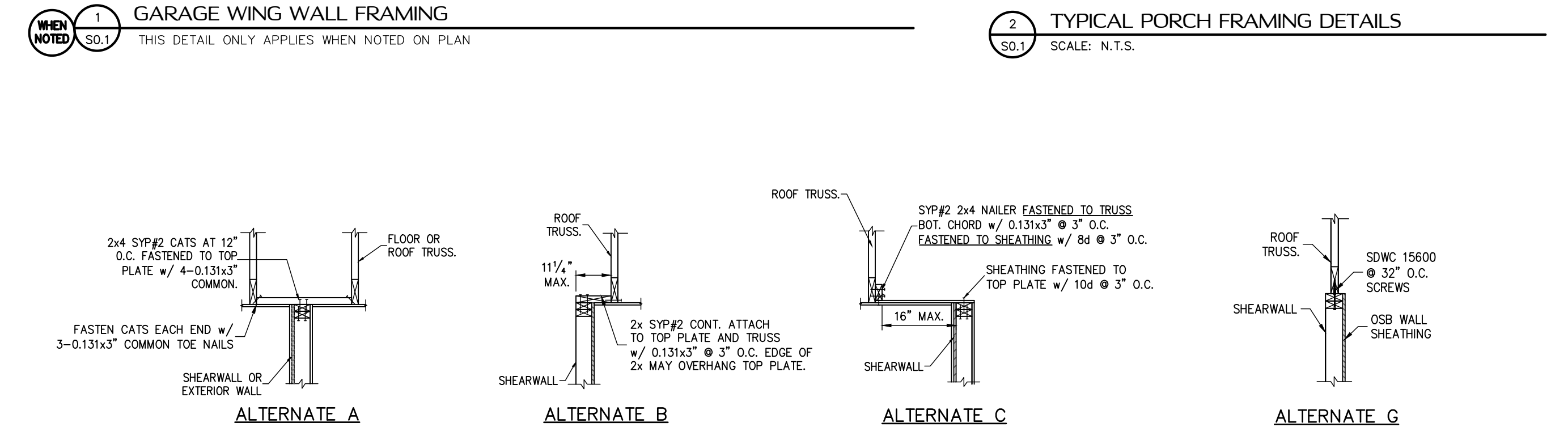

5 SHEARWALL ATTACHMENT AT ROOF & FLOOR
 SO.1

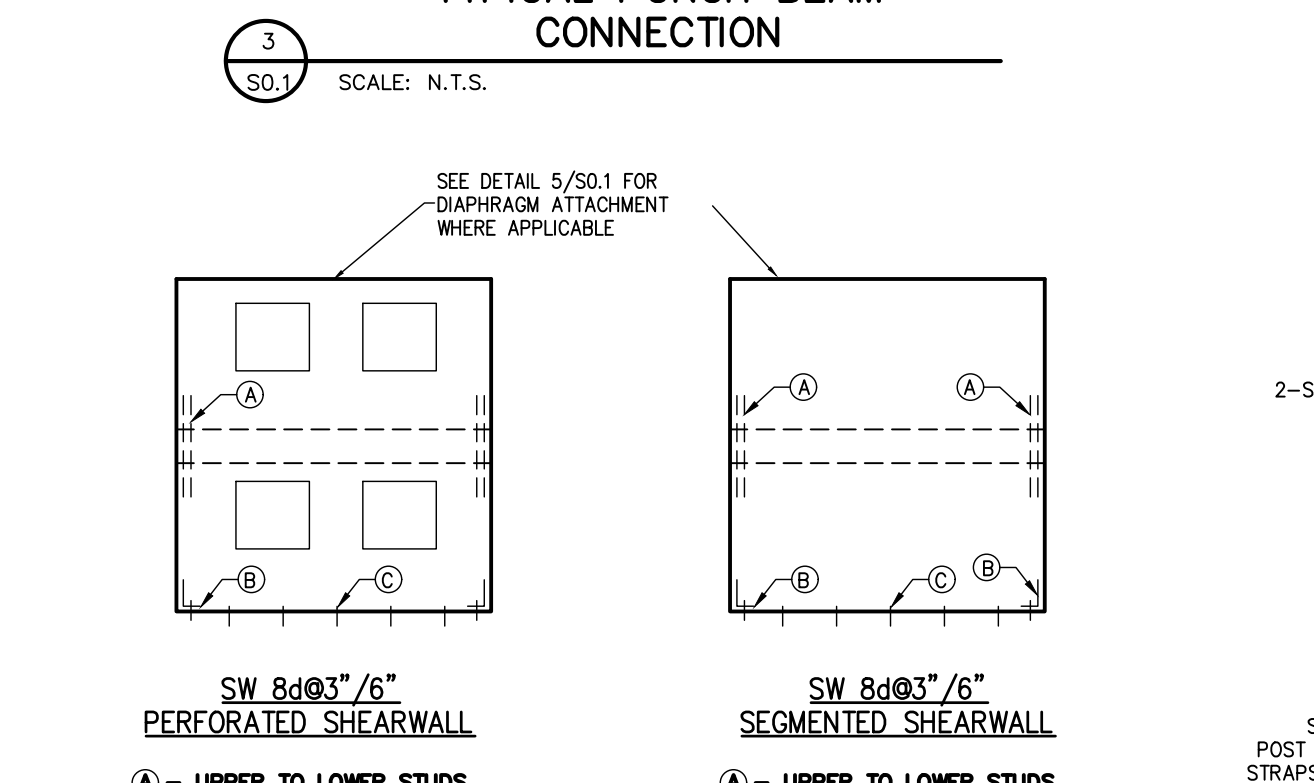

6 TYPICAL SHEARWALL ELEVATION
 SO.1 PROVIDE SOLID BLOCKING WITHIN FLOOR SYSTEM AT SW END POSTS.

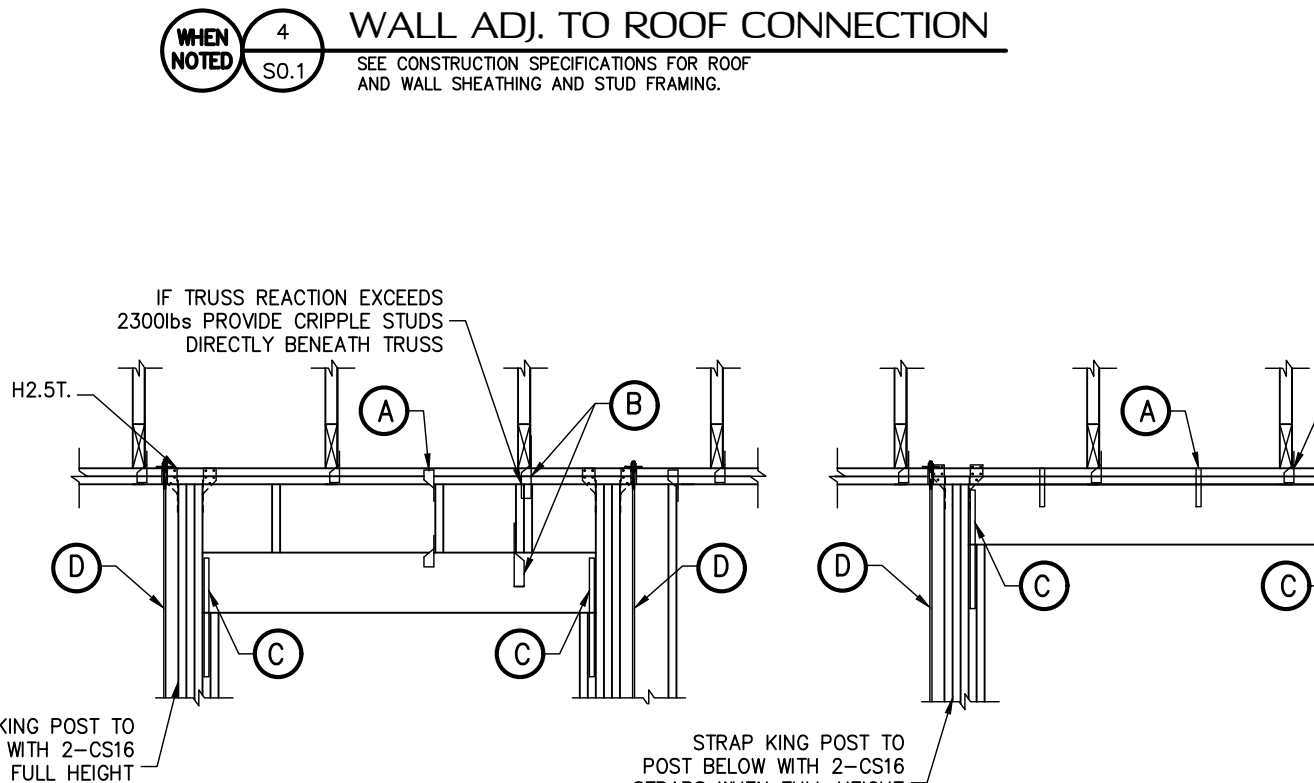

7 HEADER TIE DOWN
 SO.1 THIS DETAIL ONLY APPLIES WHEN NOTED ON PLAN

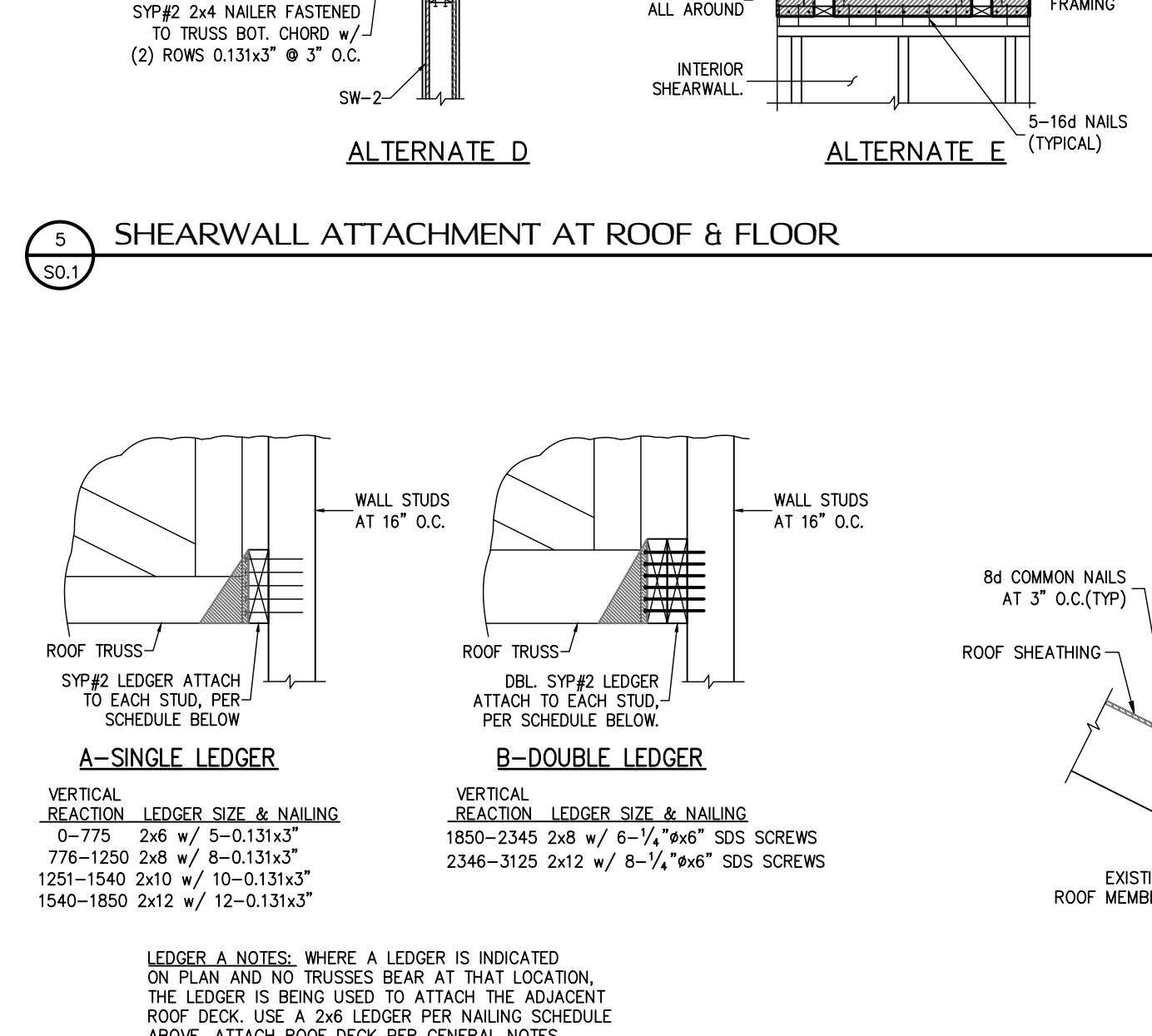

8 LEDGER CONNECTION
 SO.1 TRUSS TO LEDGER CONNECTION BY TRUSS ENGINEER NOT SHOWN FOR CLARITY

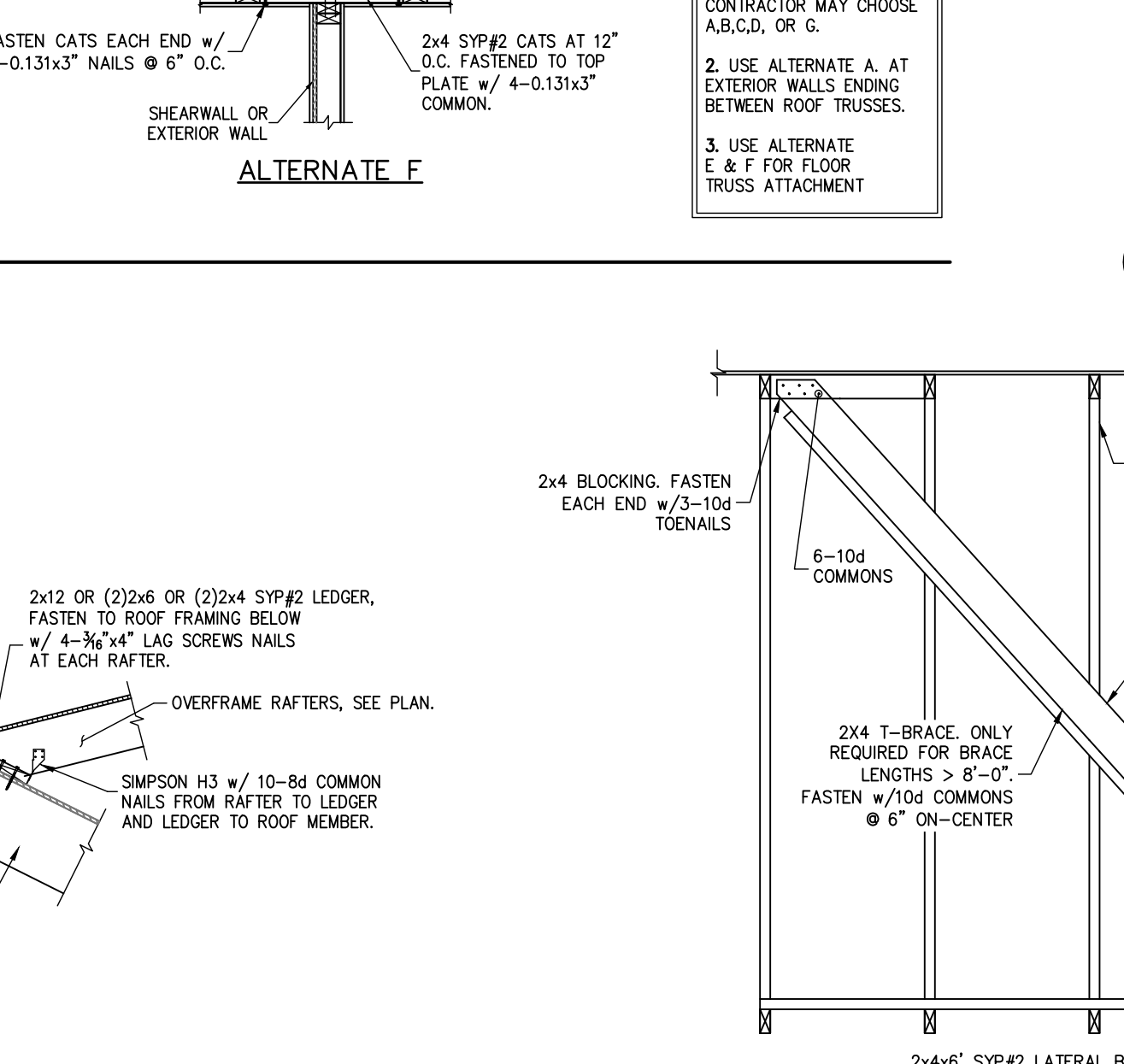

9 DECK LEDGER AT OVERFRAME RAFTERS
 SO.1 USE THIS DETAIL TO FASTEN OVERFRAMED ROOFS, VALLEYS, ETC.

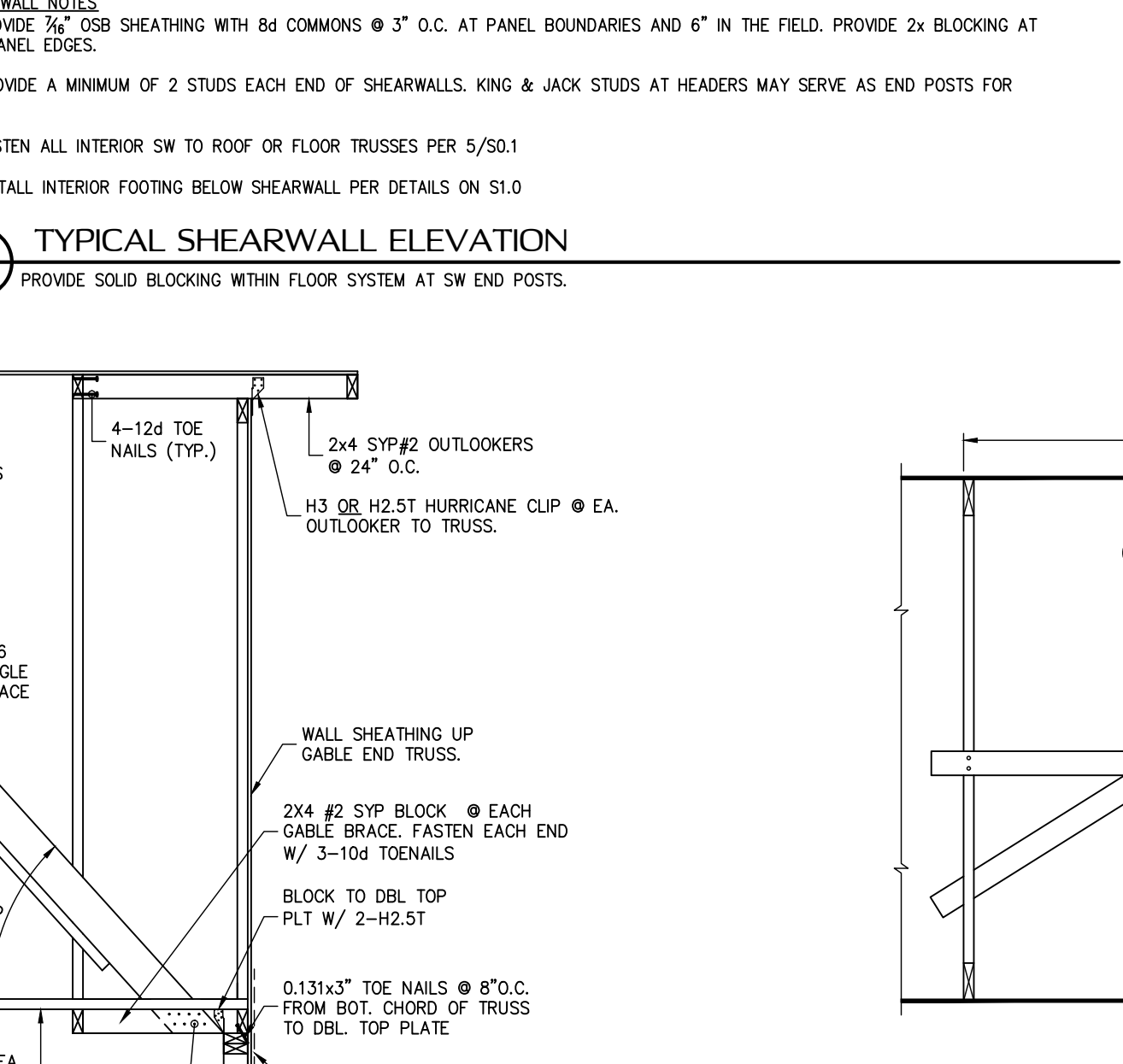

10 GABLE END BRACING
 SO.1 NOTES: 1. SPACE GABLE END BRACING @ 4'-6" MAX. 2. ALL MATERIAL TO BE SYP#2

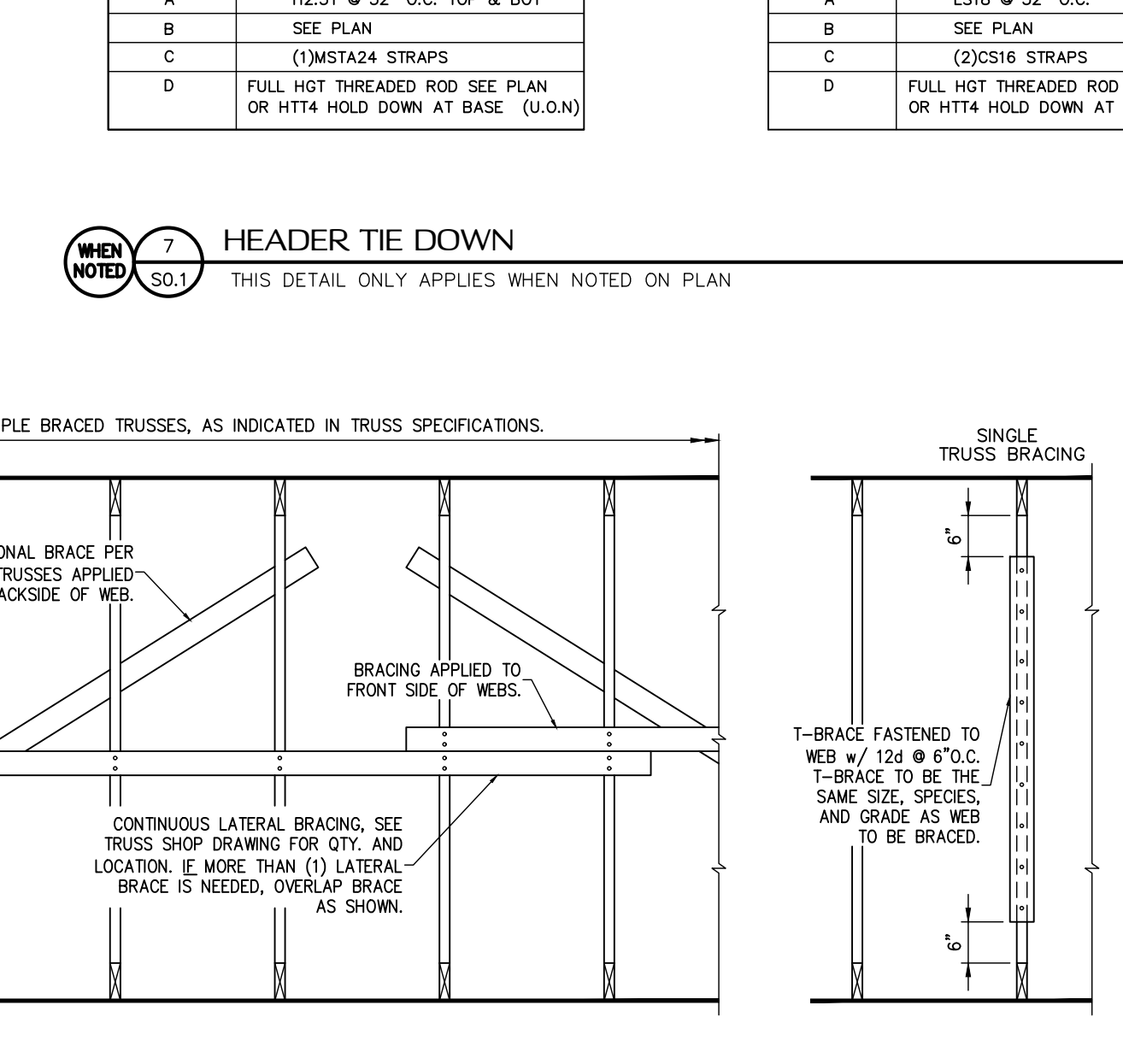

11 PERMANENT TRUSS BRACING
 SO.1 SCALE: 3/4" = 1'-0"

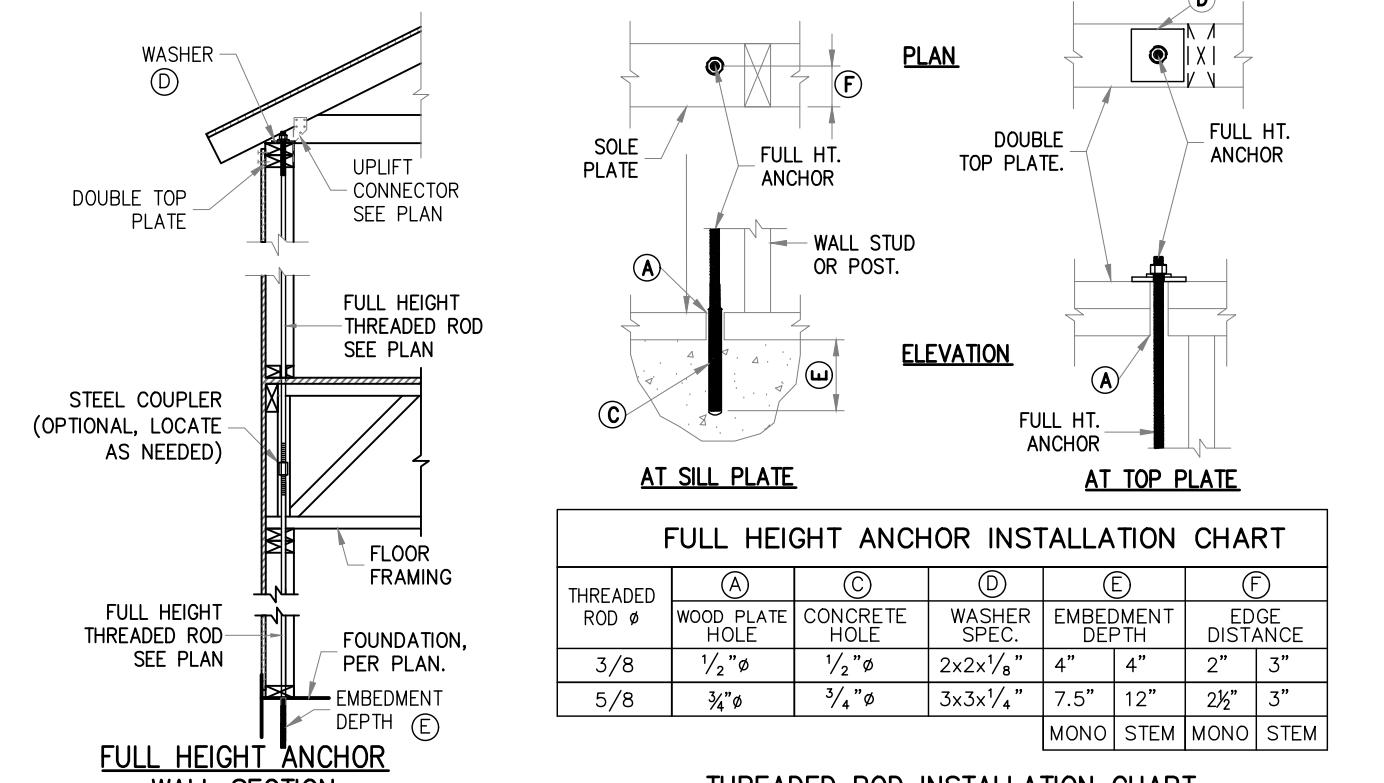

12 FULL HEIGHT WOOD FRAME WALL ANCHORING SYSTEM
 SO.1 THIS DETAIL ONLY APPLIES WHEN NOTED ON PLAN

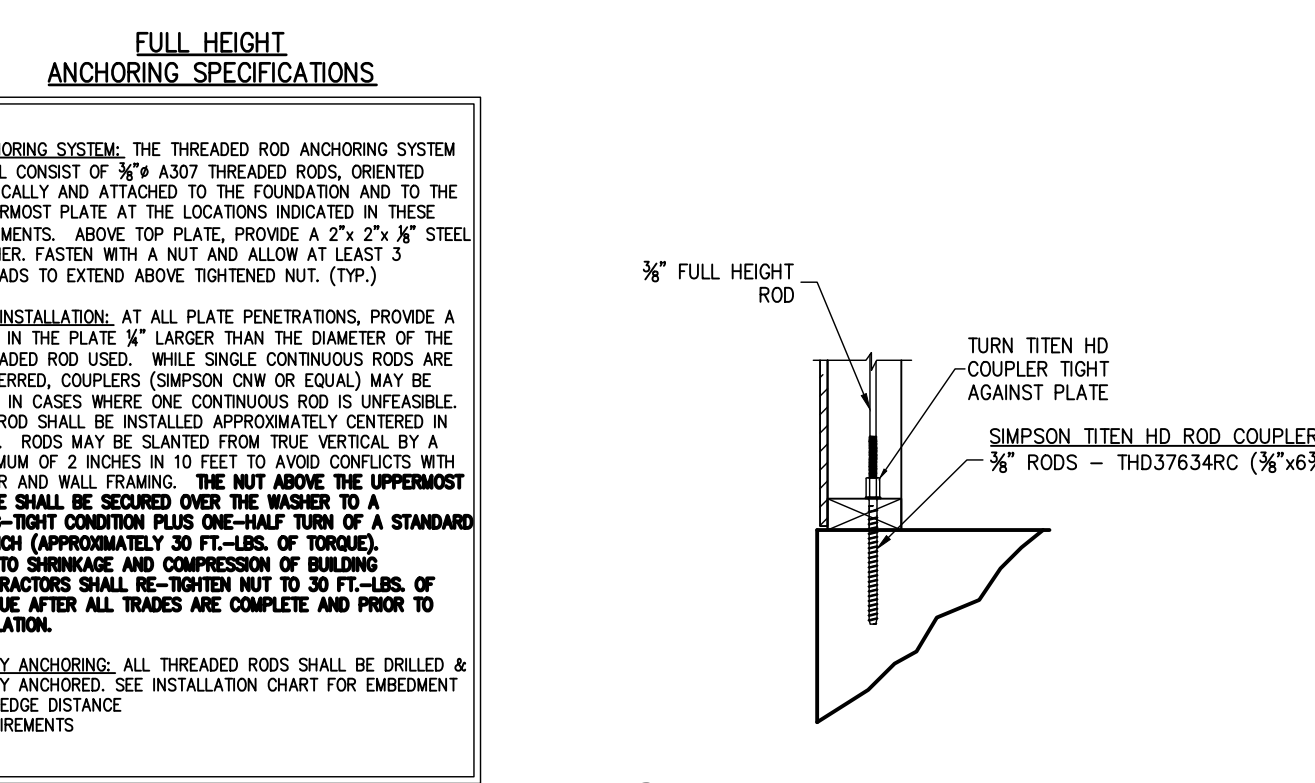

13 3/8" FULL HEIGHT ROD ALTERNATE ATTACHMENT
 SO.1

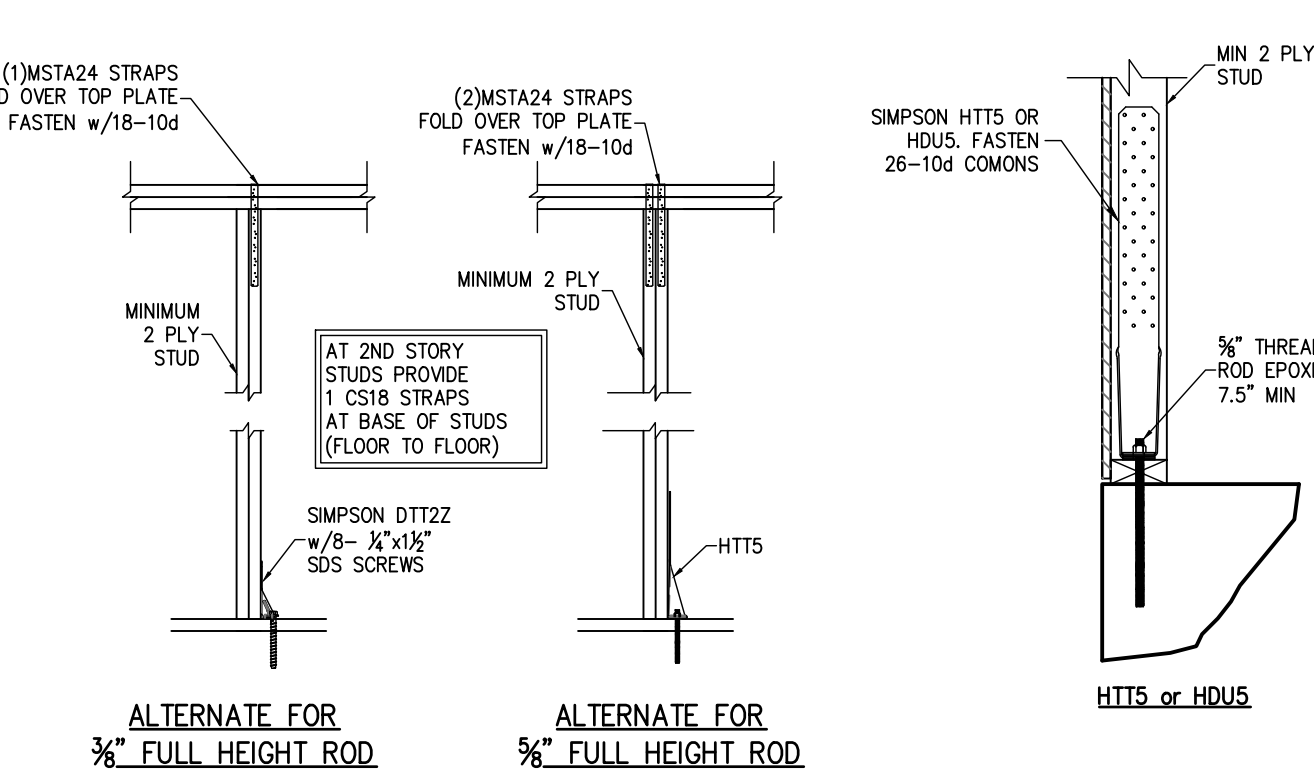

14 FULL HEIGHT THREADED ROD ALTERNATE
 SO.1

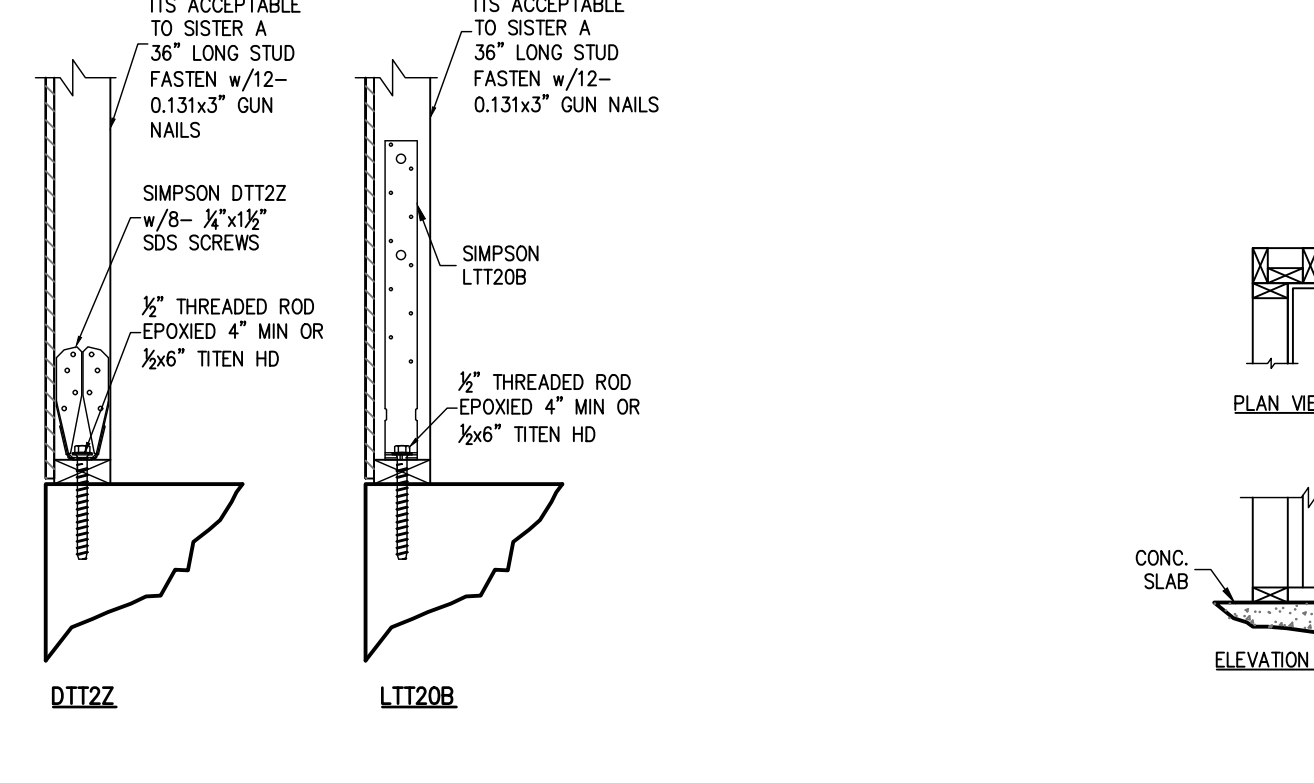

15 HOLD DOWN ATTACHMENT DETAIL
 SO.1

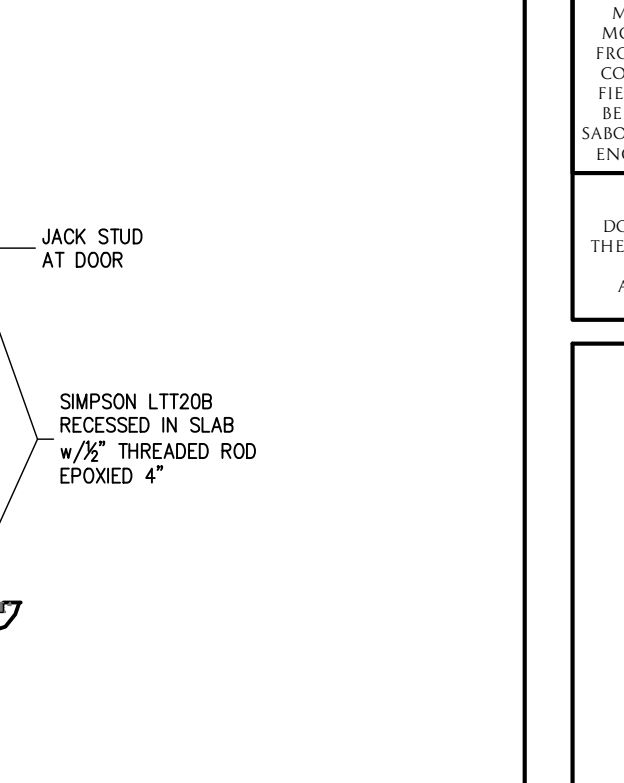

16 DOOR JAMB FASTENING
 SO.1 THIS DETAIL ONLY APPLIES WHEN NOTED ON PLAN

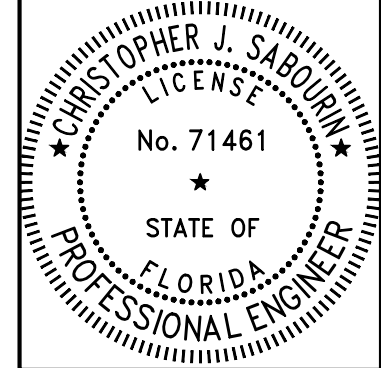

Christopher J. Sabourin
 FL PE #71461

SABO STRUCTURAL ENGINEERING
 CA#32529
 235 9TH AVE N
 JAX BEACH, FL 32250
 904-712-5750
 CHRIS@SABOENG.COM

PLAN NAME
 BZEC MCKINZEY
 SSE No.
 23-0385

ISSUE	DATE
PERMIT	08.01.23
REVISIONS	DATE

STRUCTURAL ENGINEERING FOR MCKINZEY RESIDENCE

FIELD ALTERATION
 CONTRACTOR SHALL CONTACT SABO STRUCTURAL ENGINEERING PRIOR TO MAKING ANY STRUCTURAL FIELD MODIFICATIONS WHICH MAY VARY FROM THE INTENT OF THE ORIGINAL CONSTRUCTION DOCUMENTS. ANY FIELD ALTERATIONS MADE PRIOR TO BEING APPROVED BY CHRISTOPHER J. SABOURIN MAY RESULT IN ADDITIONAL ENGINEERING OR INSPECTION FEES.

SCALING
 DO NOT SCALE DIMENSIONS FROM THESE DRAWINGS. IF A DIMENSION IS UNCLEAR REFER TO THE ARCHITECTURAL DRAWINGS OR CONTACT THE E.O.R.

TYPICAL FRAMING DETAILS

CONTRACTOR TO
VERIFY DIMENSIONS

SYMBOLS LEGEND	
	DESIGNATES FOOTING LINE
	DESIGNATES SAWCUT LINE
	STEM WALL FOOTING
	DESIGNATES SLAB RECESS

CHRISTOPHER J. SABOURIN
LICENSE
No. 71461
STATE OF
FLORIDA
PROFESSIONAL ENGINEER

08.01.23
Christopher J Sabourin
FL PE#71461

SABO
STRUCTURAL
ENGINEERING
CA#32529
235 9TH AVE N
JAX BEACH, FL 32250
904-712-5750
CHRIS@SABOENG.COM

PLAN NAME
BZEC MCKINZEY

SSE No.
23-0385

ISSUE	DATE
PERMIT	08.01.23
REVISIONS	DATE

STRUCTURAL ENGINEERING FOR
MCKINZEY RESIDENCE

FIELD ALTERATION
CONTRACTOR SHALL CONTACT SABO
STRUCTURAL ENGINEERING PRIOR TO
MAKING ANY STRUCTURAL FIELD
MODIFICATIONS WHICH MAY VARY
FROM THE INTENT OF THE ORIGINAL
CONSTRUCTION DOCUMENTS. ANY
FIELD ALTERATIONS MADE PRIOR TO
BEING APPROVED BY CHRISTOPHER
SABOURIN MAY RESULT IN ADDITIONAL
ENGINEERING OR INSPECTION FEES.

SCALING
DO NOT SCALE DIMENSIONS FROM
THESE DRAWINGS. IF A DIMENSION IS
UNCLEAR REFER TO THE
ARCHITECTURAL DRAWINGS OR
CONTACT THE E.O.R.

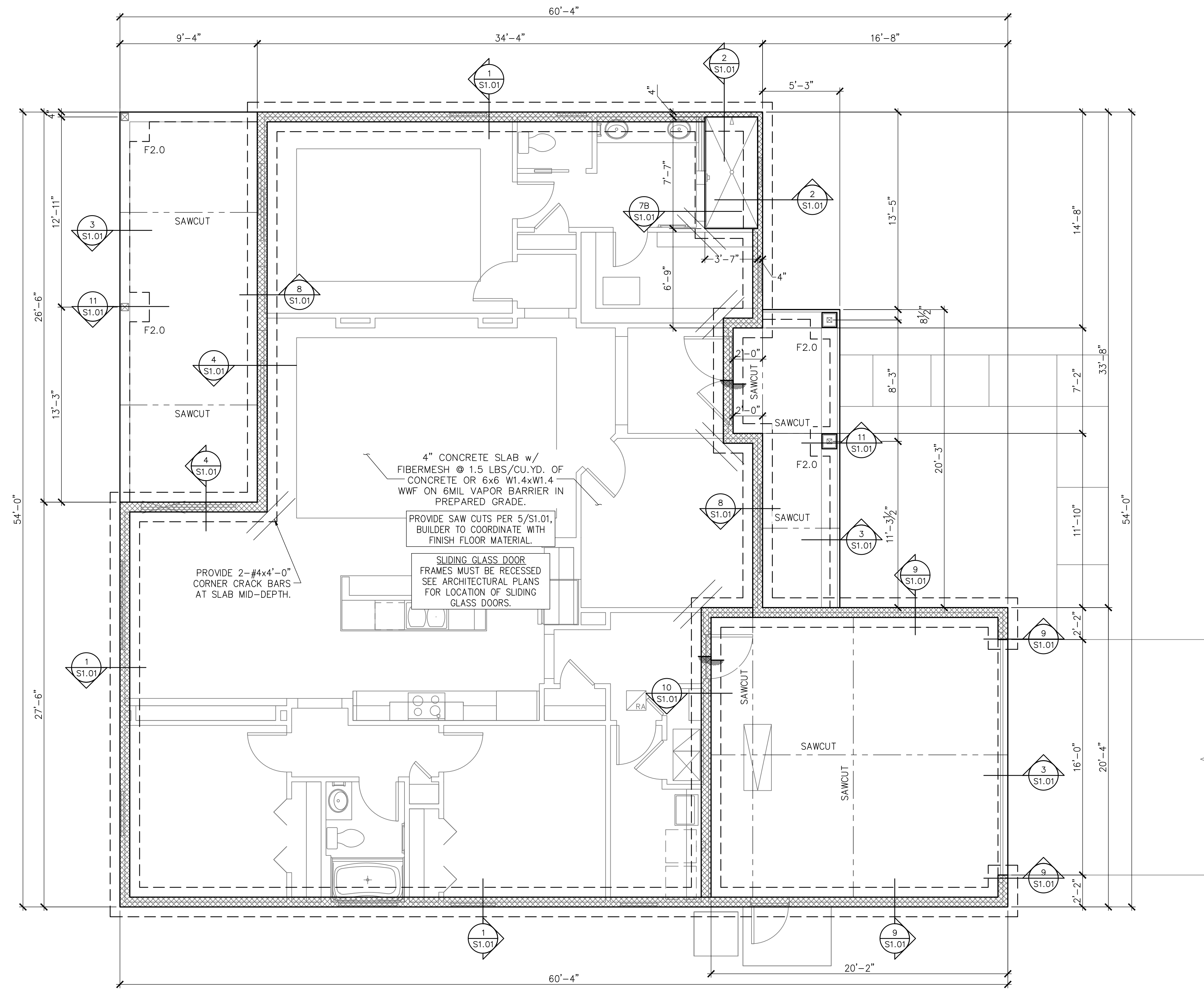

FOOTING SCHEDULE AND NOTES				
TYPE	LENGTH	WIDTH	DEPTH	BOTTOM BARS
F2.0	2'-0"	2'-0"	1'-0"	3-#5 EA. WAY BOT.
F2.5	2'-6"	2'-6"	1'-0"	3-#5 EA. WAY BOT.
F3.0	3'-0"	3'-0"	1'-0"	3-#5 EA. WAY BOT.
F3.5	3'-6"	3'-6"	1'-0"	4-#5 EA. WAY BOT.
F4.0	4'-0"	4'-0"	1'-0"	4-#5 EA. WAY BOT.
F4.5	4'-6"	4'-6"	1'-0"	4-#5 EA. WAY BOT.

- THIS FOUNDATION PLAN ONLY CONVEYS STRUCTURAL INFO. RELATED TO THE FOUNDATION. FOR GENERAL FEATURES, DIMENSIONS, CONDUITS, ELECTRICAL EMBEDS, STEP HEIGHTS, ECT., SEE ARCH. PLAN. ARCHITECTURAL PLAN SHOWN HERE IN FOR REFERENCE ONLY.
- FTGS. & FND. SHALL BE IN ACCORDANCE w/ LOCAL BUILDING CODES.
- SOIL COMPACTION AND FILL SHALL BE COMPACTED TO A MIN. OF 95% MODIFIED PROCTOR IN ACCORDANCE WITH ASTM D 1557.

FOUNDATION PLAN
SCALE: 1/4" = 1'-0"

FOUNDATION
PLAN

SHEET
S1.0
SHEET 3 OF 7

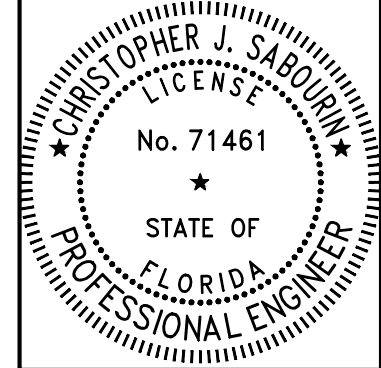

Christopher J. Sabourin
FL PE #71461

SABO
STRUCTURAL
ENGINEERING
CA#32529
235 9TH AVE N
JAX BEACH, FL 32250
904-712-5750
CHRIS@SABOENG.COM

PLAN NAME
BZEC MCKINZEY
SSE No.
23-0385

ISSUE	DATE
PERMIT	08.01.23
REVISIONS	DATE

STRUCTURAL ENGINEERING FOR
MCKINZEY RESIDENCE

FIELD ALTERATION
CONTRACTOR SHALL CONTACT SABO STRUCTURAL ENGINEERING PRIOR TO MAKING ANY STRUCTURAL FIELD MODIFICATIONS WHICH MAY VARY FROM THE INTENT OF THE ORIGINAL CONSTRUCTION DOCUMENTS. ANY FIELD ALTERATIONS MADE PRIOR TO BEING APPROVED BY CHRISTOPHER J. SABOURIN MAY RESULT IN ADDITIONAL ENGINEERING OR INSPECTION FEES.

SCALING
DO NOT SCALE DIMENSIONS FROM THESE DRAWINGS. IF A DIMENSION IS UNCLEAR REFER TO THE ARCHITECTURAL DRAWINGS OR CONTACT THE E.O.R.

FOUNDATION DETAILS

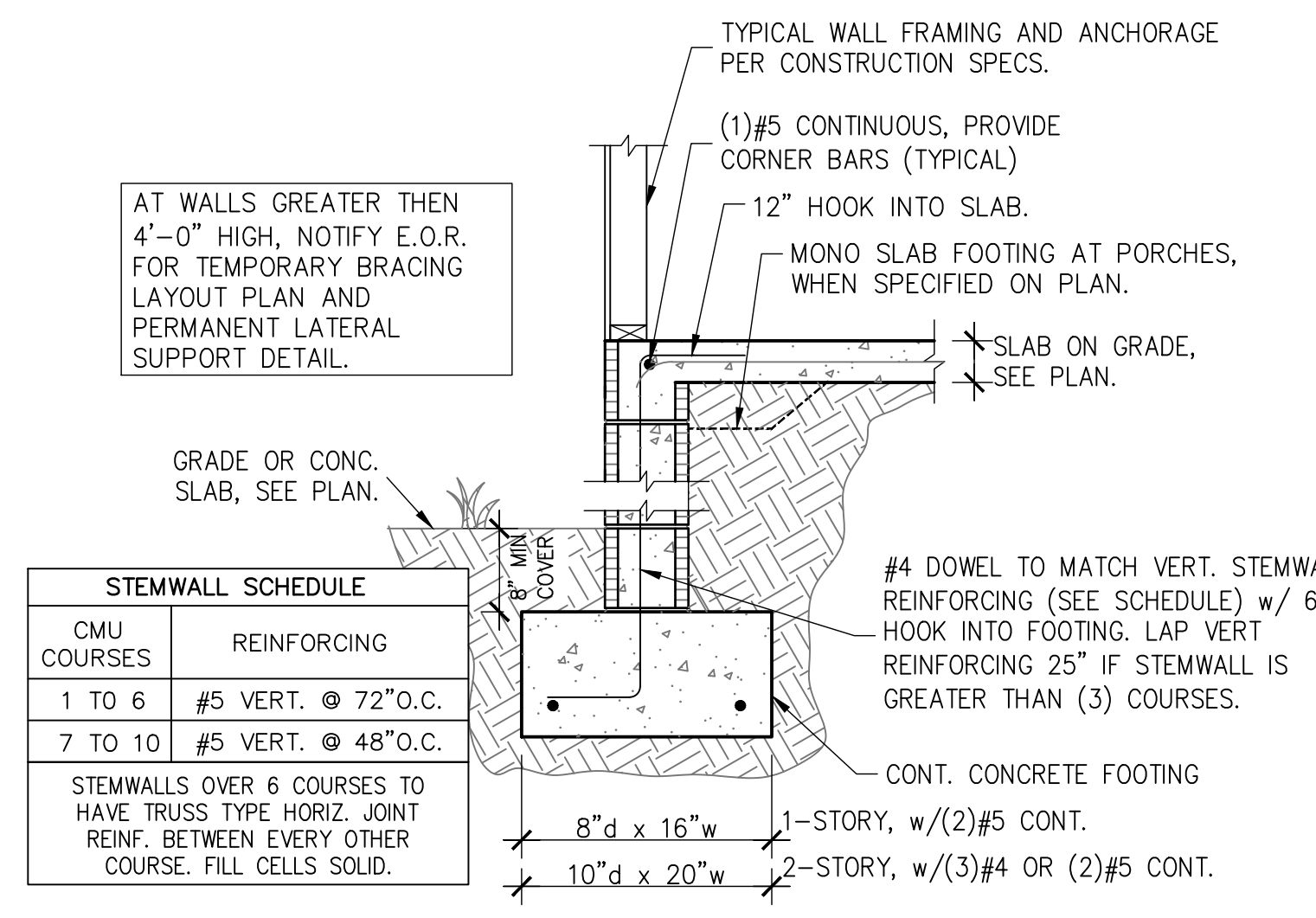

1 STEMWALL FOOTING
S1.01 SCALE: 3/4" = 1'-0"

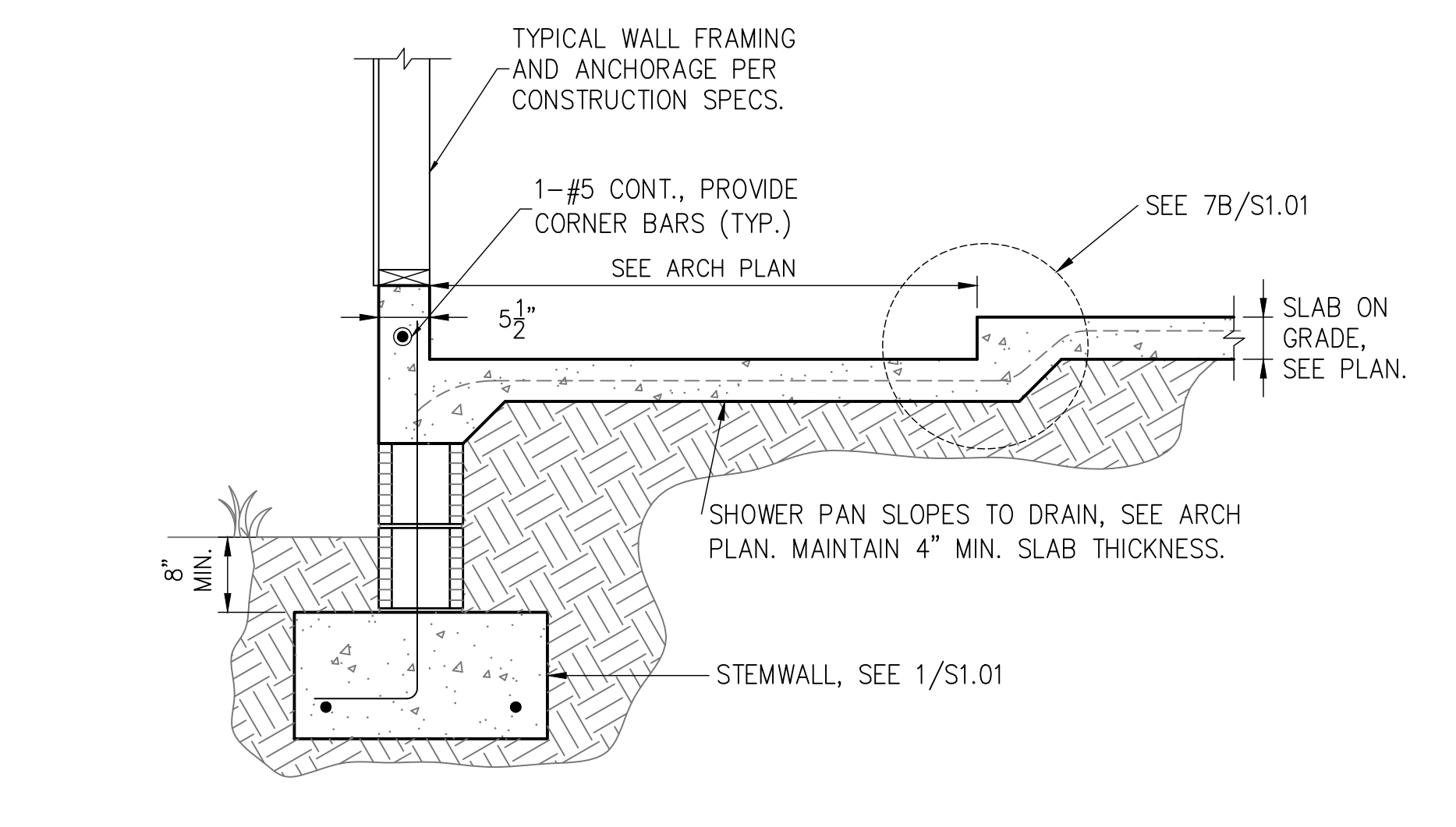

2 FOOTING W/ SHOWER RECESS
S1.01 SCALE: 3/4" = 1'-0"

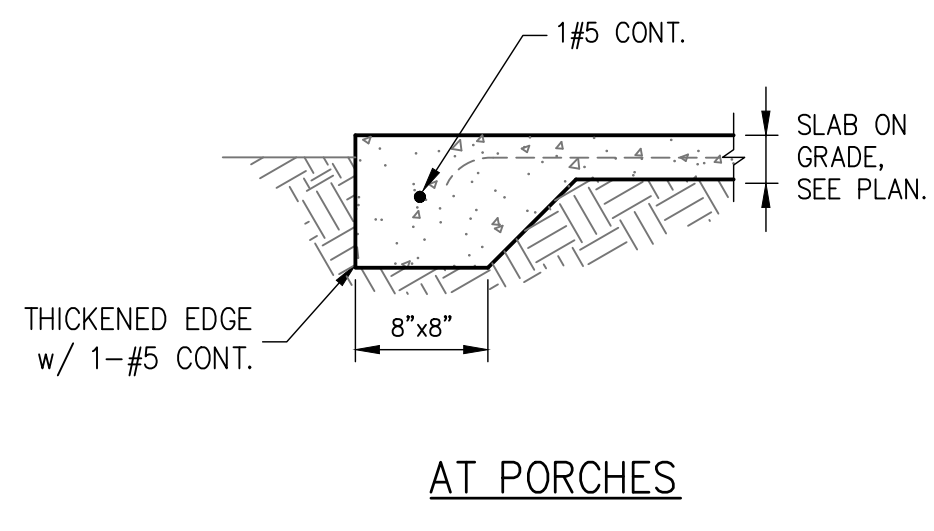
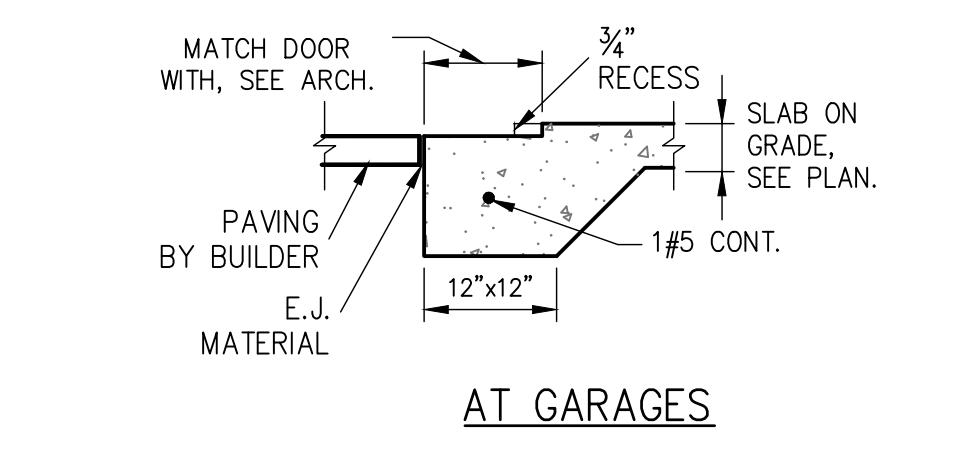

3 THICKENED SLAB
S1.01 SCALE: 3/4" = 1'-0"

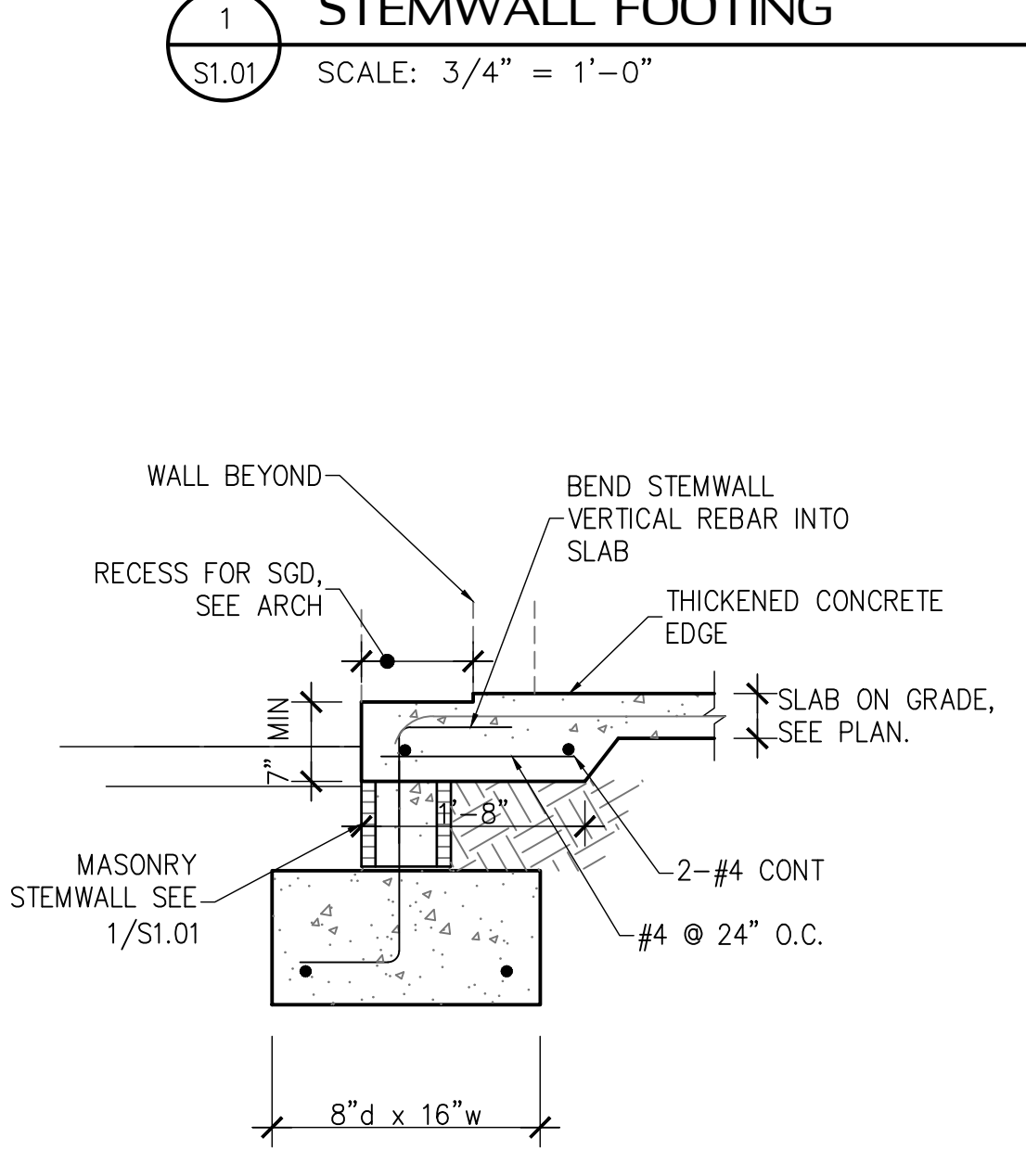

4 STEMWALL FOOTING AT SLIDER
S1.01 SCALE: 3/4" = 1'-0"

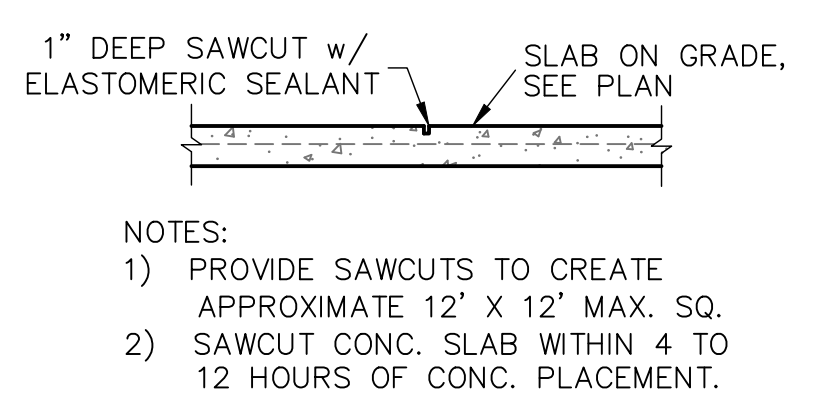

5 SAW CUT DETAIL
S1.01 SCALE: 3/4" = 1'-0"

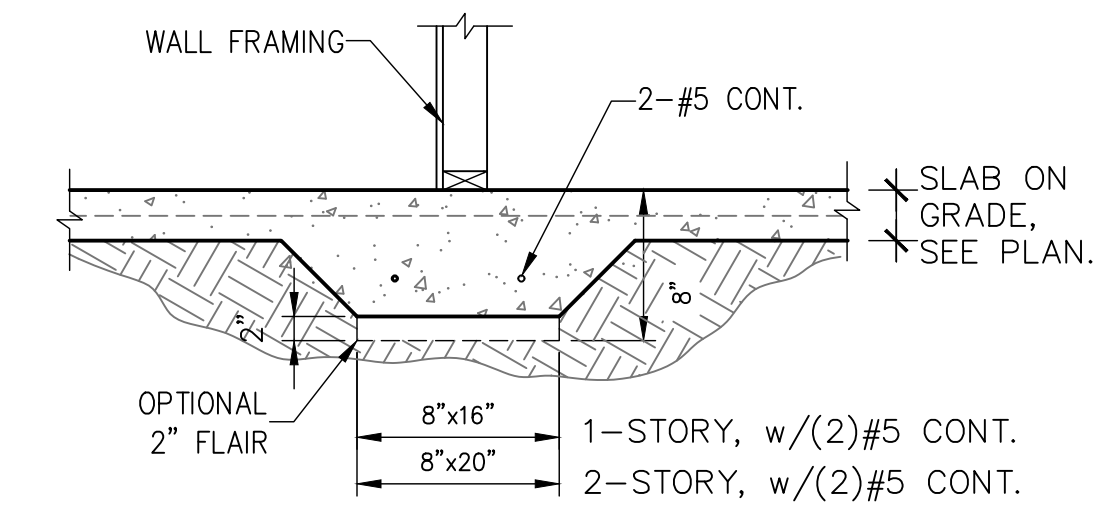

6 BEARING AT INTERIOR
S1.01 SCALE: 3/4" = 1'-0"

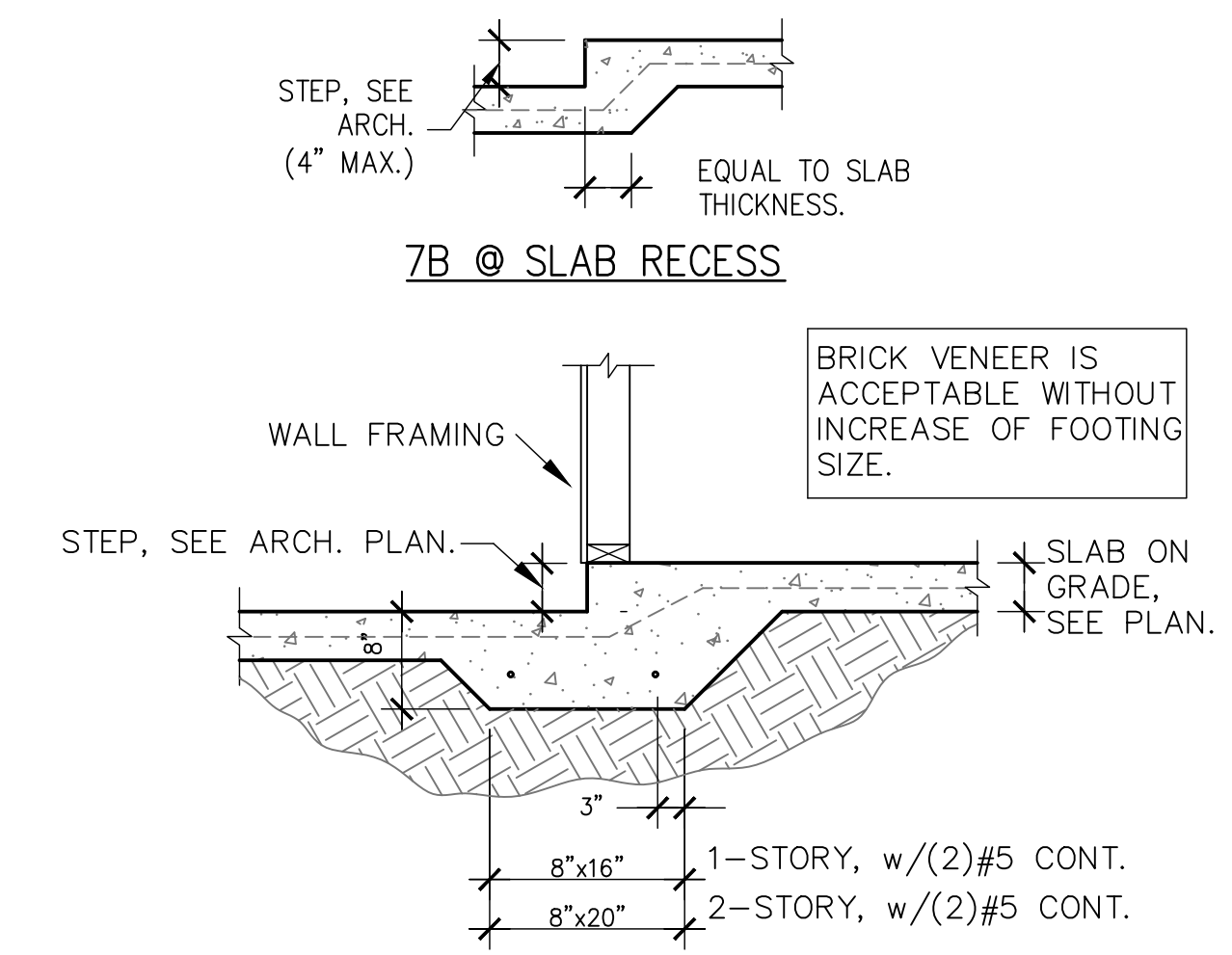

7 MONO. FOOTING AT STEP-DOWN
S1.01 SCALE: 3/4" = 1'-0"

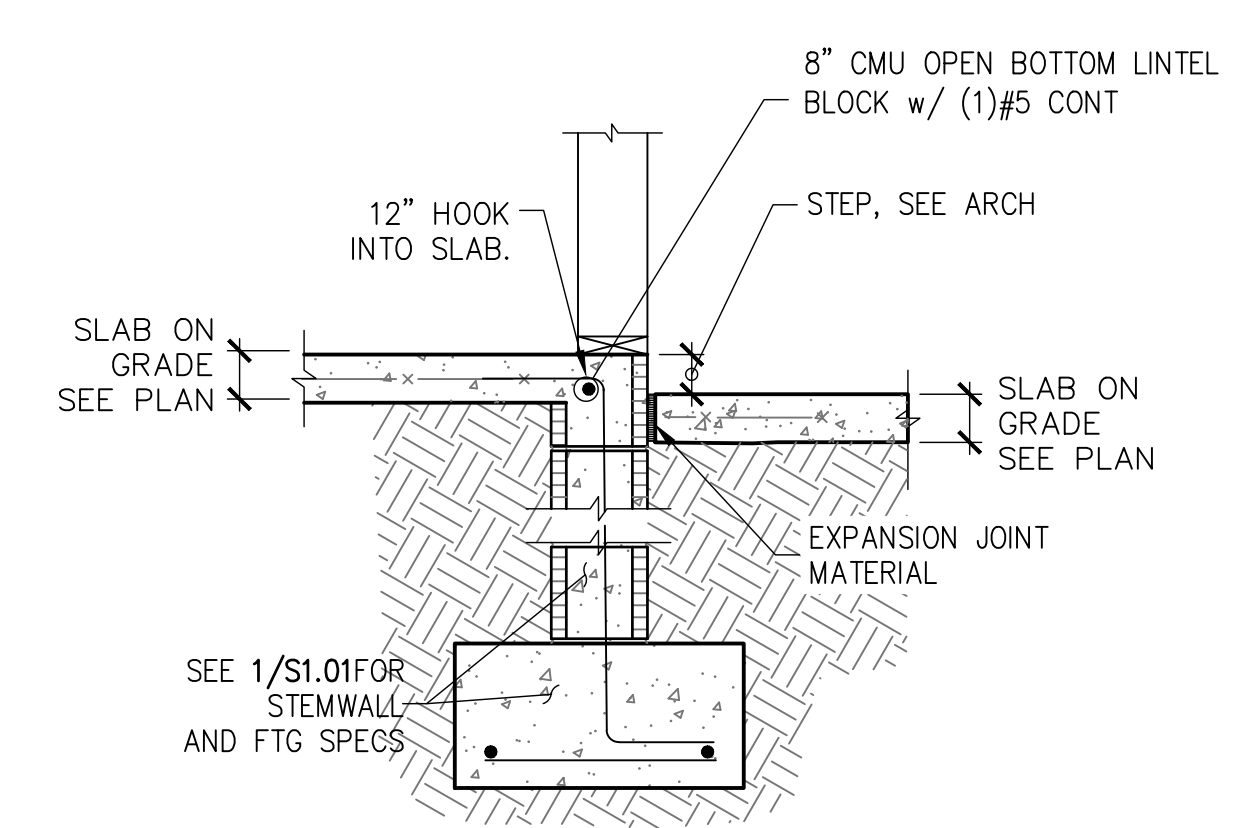

8 STEP AT STEMWALL
S1.01 SCALE: 3/4" = 1'-0"

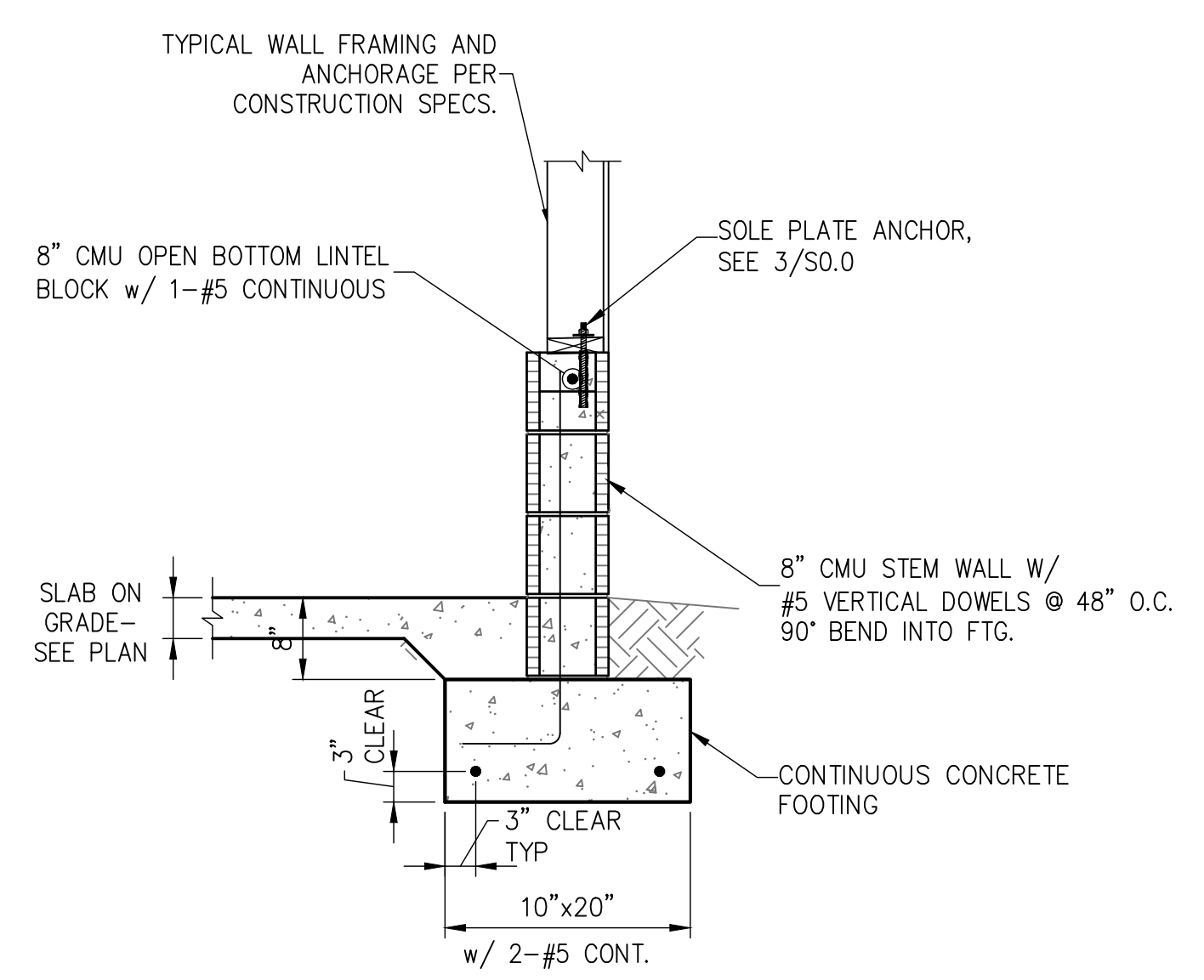

9 GARAGE STEM WALL
S1.01 SCALE: 3/4" = 1'-0"

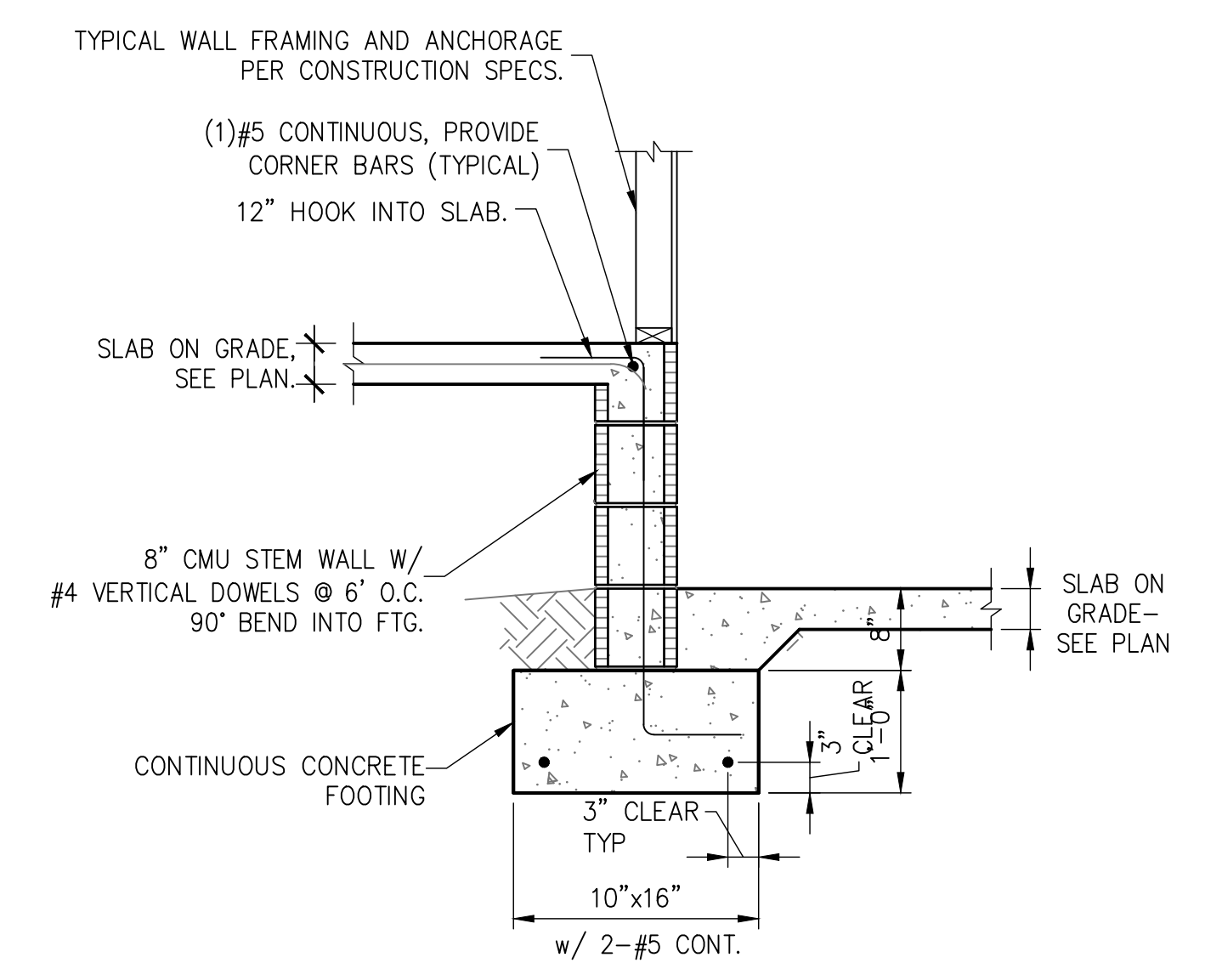

10 STEMWALL AT GARAGE
S1.01 SCALE: 3/4" = 1'-0"

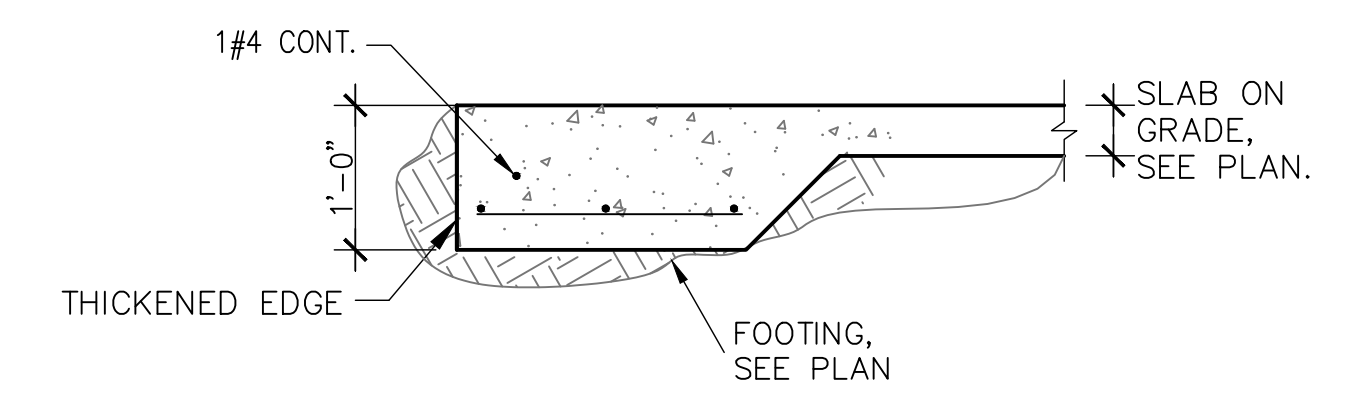

11 PEDESTAL AT PORCH SLAB
S1.01

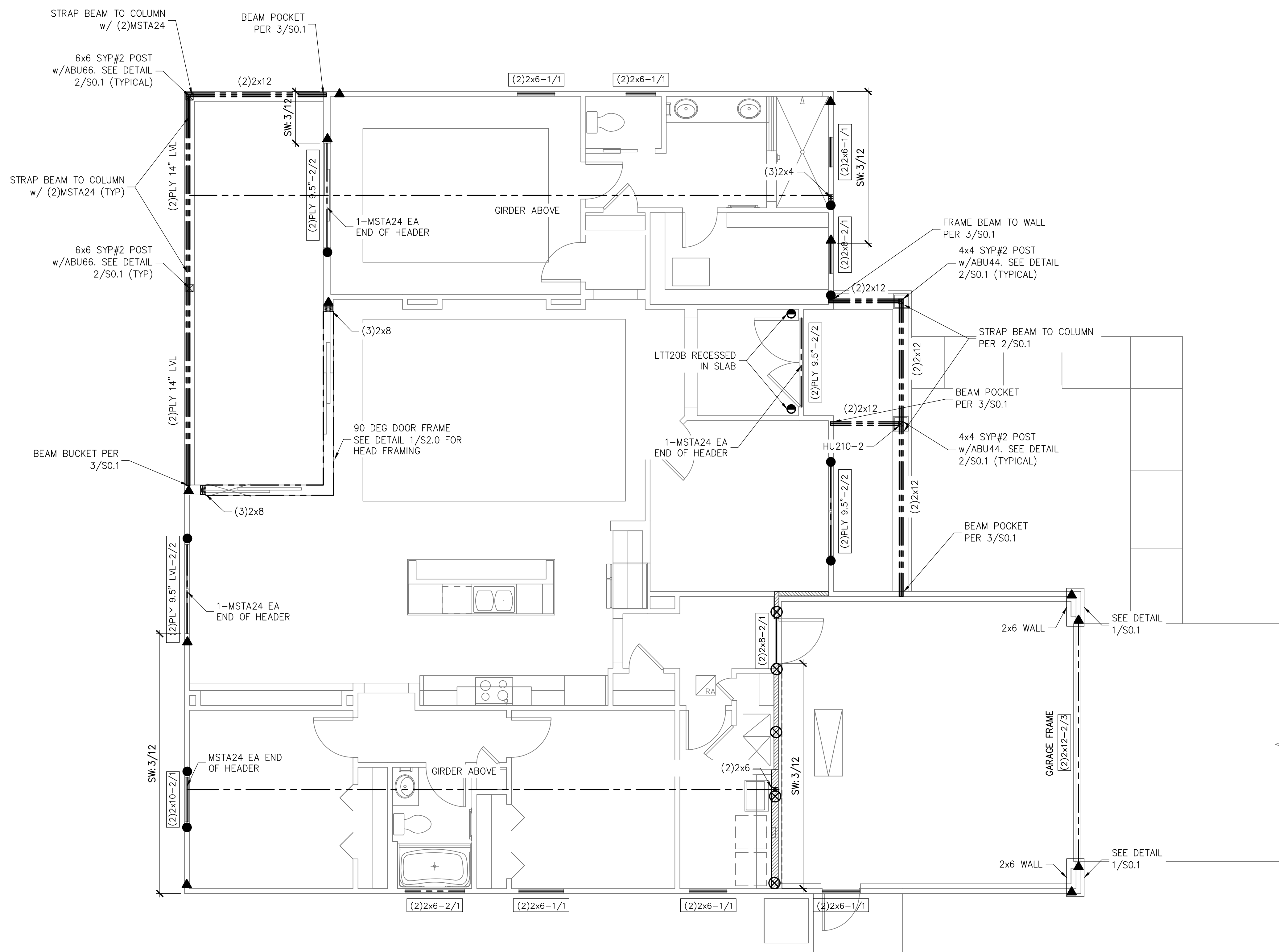

SYMBOLS LEGEND

	DESIGNATES OSB SHEARWALL. THE HIDDEN LINE DESIGNATES SIDE OF WALL. THE SHEARWALL SHEATHING TO BE APPLIED. 8d @ 6\"/>
	DESIGNATES THE HEADER SIZE, NUMBER OF PLYS & JACKING STUDS NEEDED FOR SUPPORT HEADER.
	BEAM OR TRUSS, SEE PLAN

ANCHOR LEGEND

	SIMPSON HTTS SEE DETAIL 15/SO.1
	SIMPSON DTT22 SEE DETAIL 15/SO.1
	SIMPSON LTT20B SEE DETAIL 15/SO.1

WALL STUD SCHEDULE

LOCATION	PLATE HEIGHT	STUD SIZE & SPACING
EXTERIOR	9'-1\"/>	
EXTERIOR	10'-1\"/>	
EXTERIOR	10'-1\"/>	
INTERIOR	10'-0\"/>	
INTERIOR	12'-0\"/>	

- STUD NOTES:**
- 1.) WALL STUDS SPECIFIED ON PLAN SUPERSEDE THIS TABLE
 - 2.) MINIMUM STUD SIZE AND SPACING ARE SHOWN. CONTRACTOR MAY INCREASE STUD SIZE TO MEET ARCHITECTURAL REQUIREMENTS.
 - 3.) SPF DENOTES SPRUCE PINE FIR. SYP DENOTES SOUTHERN YELLOW PINE.
 - 4.) USE SYP#2 FOR ALL TOP PLATES AND SOLE PLATES.
 - 5.) FASTEN BOTTOM PLATE OF INTERIOR LOAD BEARING WALLS TO CONCRETE SLAB w/16d MASONRY CUT NAILS @ 16\"/>

GENERAL NOTES

1. SEE DETAIL 2/SO.0 FOR WALL FRAMING DETAIL. SEE WALL STUD SCHEDULE. THIS SHEET FOR STUD SIZES AND SPACING. AT GIRDERS AND BEAMS, PROVIDE STUDS BELOW TO MATCH BEAM/GRIER PLYS.
2. SEE SHEET S.O.0 FOR ROOF AND FLOOR SHEATHING SPECIFICATIONS.
3. WHERE FRAMING MEMBERS CONSIST OF MULTIPLE PLYS (BEAMS, HEADER, AND STUDS) FASTEN PLYS TOGETHER PER DETAIL 6/SO.0
4. INSTALL SOLE PLATE ANCHORS PER DETAIL 3/SO.0
5. AT SHEARWALLS, PROVIDE DIAPHRAGM ATTACHMENT PER DETAIL 5/SO.1
6. FOR ATTACHMENT OF EXTERIOR WALLS THAT TERMINATE BETWEEN TRUSSES, SEE 5A/SO.1
7. AT PORCHES, SEE DETAIL 2/SO.1 FOR FRAMING AND HOLD DOWNS

SOLE PLATE ANCHOR SPACING SCHD

ALL EXTERIOR WALL UNLESS OTHER NOTED	42\"/>
SHEARWALLS (SW 8d@3\"/>	
SOLE PLT. #	WHEN NOTED ON PLAN SEE NOTE 2

1. INSTALL SOLE PLATE ANCHORS PER DETAIL 3/SO.0
2. ANCHOR SPACING SHALL BE AS NOTED. FOR EXAMPLE - SOLE PLT @ 36\"/>

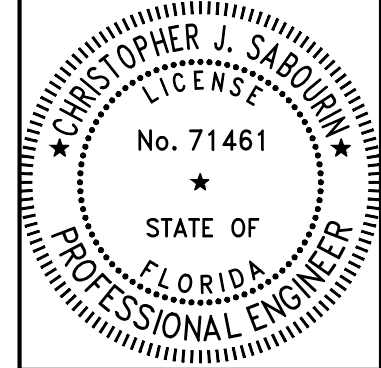

Christopher J Sabourin
FL PE#71461

SABO STRUCTURAL ENGINEERING
CA#32529
235 9TH AVE N
JAX BEACH, FL 32250
904-712-5750
CHRIS@SABOENG.COM

PLAN NAME
BZEC MCKINZEY

SSE No.
23-0385

ISSUE	DATE
PERMIT	08.01.23
REVISIONS	DATE

STRUCTURAL ENGINEERING FOR MCKINZEY RESIDENCE

FIELD ALTERATION
CONTRACTOR SHALL CONTACT SABO STRUCTURAL ENGINEERING PRIOR TO MAKING ANY STRUCTURAL FIELD MODIFICATIONS WHICH MAY VARY FROM THE INTENT OF THE ORIGINAL CONSTRUCTION DOCUMENTS. ANY FIELD ALTERATIONS MADE PRIOR TO BEING APPROVED BY CHRISTOPHER SABOURIN MAY RESULT IN ADDITIONAL ENGINEERING OR INSPECTION FEES.

SCALING
DO NOT SCALE DIMENSIONS FROM THESE DRAWINGS. IF A DIMENSION IS UNCLEAR REFER TO THE ARCHITECTURAL DRAWINGS OR CONTACT THE E.O.R.

FIRST LEVEL WALL FRAMING PLAN

SHEET
S1.1
SHEET 5 OF 7

FIRST LEVEL WALL FRAMING PLAN
SCALE: 1/4" = 1'-0"

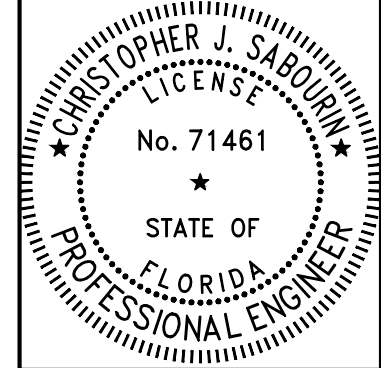

08.01.23
Christopher J. Sabourin
FL PE#71461

SABO
STRUCTURAL
ENGINEERING
CA#32529
235 9TH AVE N
JAX BEACH, FL 32250
904-712-5750
CHRIS@SABOENG.COM

PLAN NAME
BZEC MCKINZEY
SSE No.
23-0385

ISSUE	DATE
PERMIT	08.01.23
REVISIONS	DATE

STRUCTURAL ENGINEERING FOR
MCKINZEY RESIDENCE

FIELD ALTERATION
CONTRACTOR SHALL CONTACT SABO
STRUCTURAL ENGINEERING PRIOR TO
MAKING ANY STRUCTURAL FIELD
MODIFICATIONS WHICH MAY VARY
FROM THE INTENT OF THE ORIGINAL
CONSTRUCTION DOCUMENTS. ANY
FIELD ALTERATIONS MADE PRIOR TO
BEING APPROVED BY CHRISTOPHER
SABOURIN MAY RESULT IN ADDITIONAL
ENGINEERING OR INSPECTION FEES.

SCALING
DO NOT SCALE DIMENSIONS FROM
THESE DRAWINGS. IF A DIMENSION IS
UNCLEAR REFER TO THE
ARCHITECTURAL DRAWINGS OR
CONTACT THE E.O.R.

**ROOF TRUSS
PLACEMENT
PLAN**

SHEET
S1.2
SHEET 6 OF 7

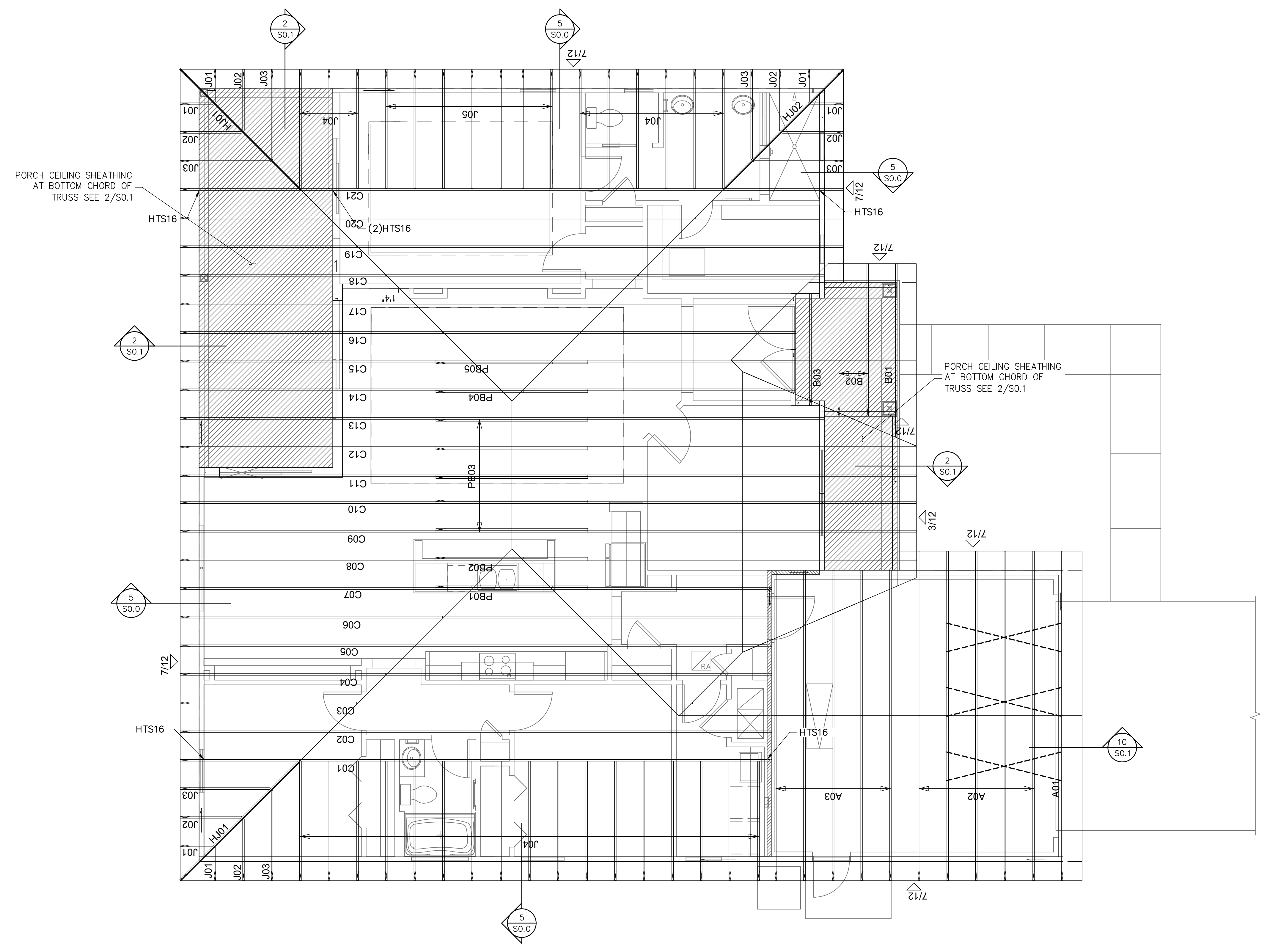

TRUSS / ROOF RAFTER NOTES: STRAPPING NOTES

- STRAP ROOF TRUSSES AND RAFTERS TO BEARING WITH 2-12D TOENAILS & H2.5 SCREW UNLESS OTHERWISE NOTED

ROOF TRUSS PLACEMENT PLAN
SCALE: 1/4" = 1'-0"

BUILDER TO VERIFY THAT TRUSSES HAVE BEEN DESIGNED FOR 100# POINT LOADS AT MITERED GLASS INTERSECTIONS.

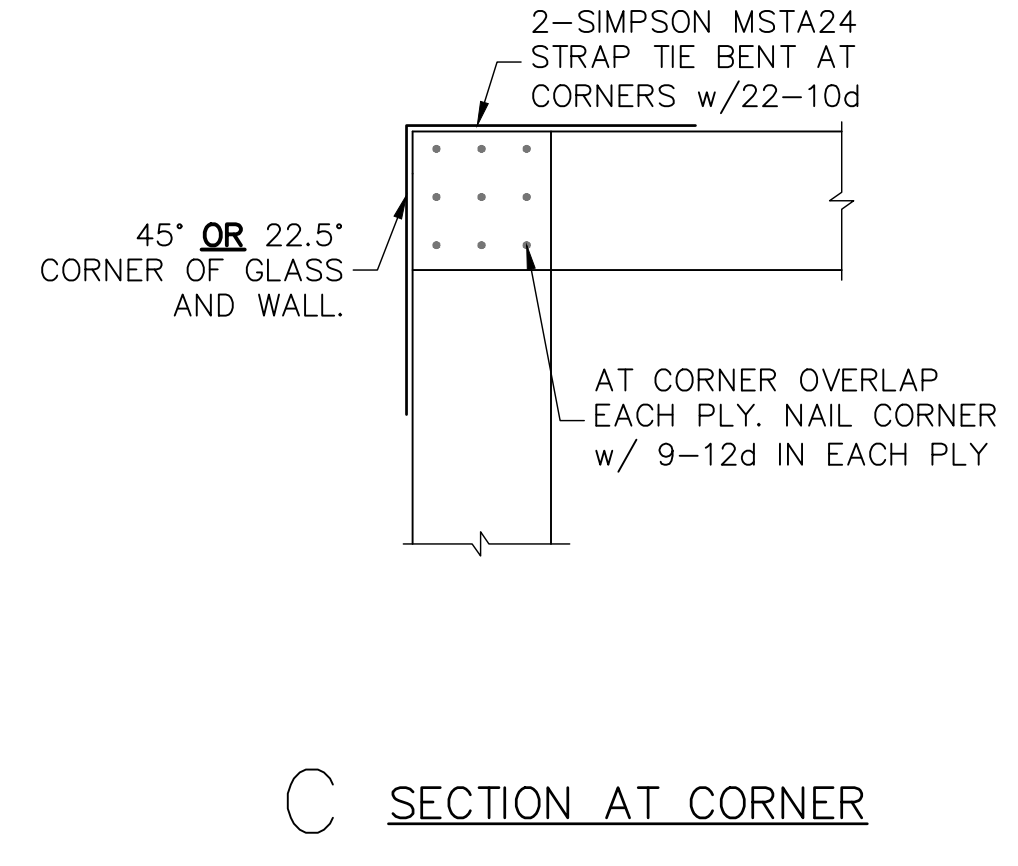
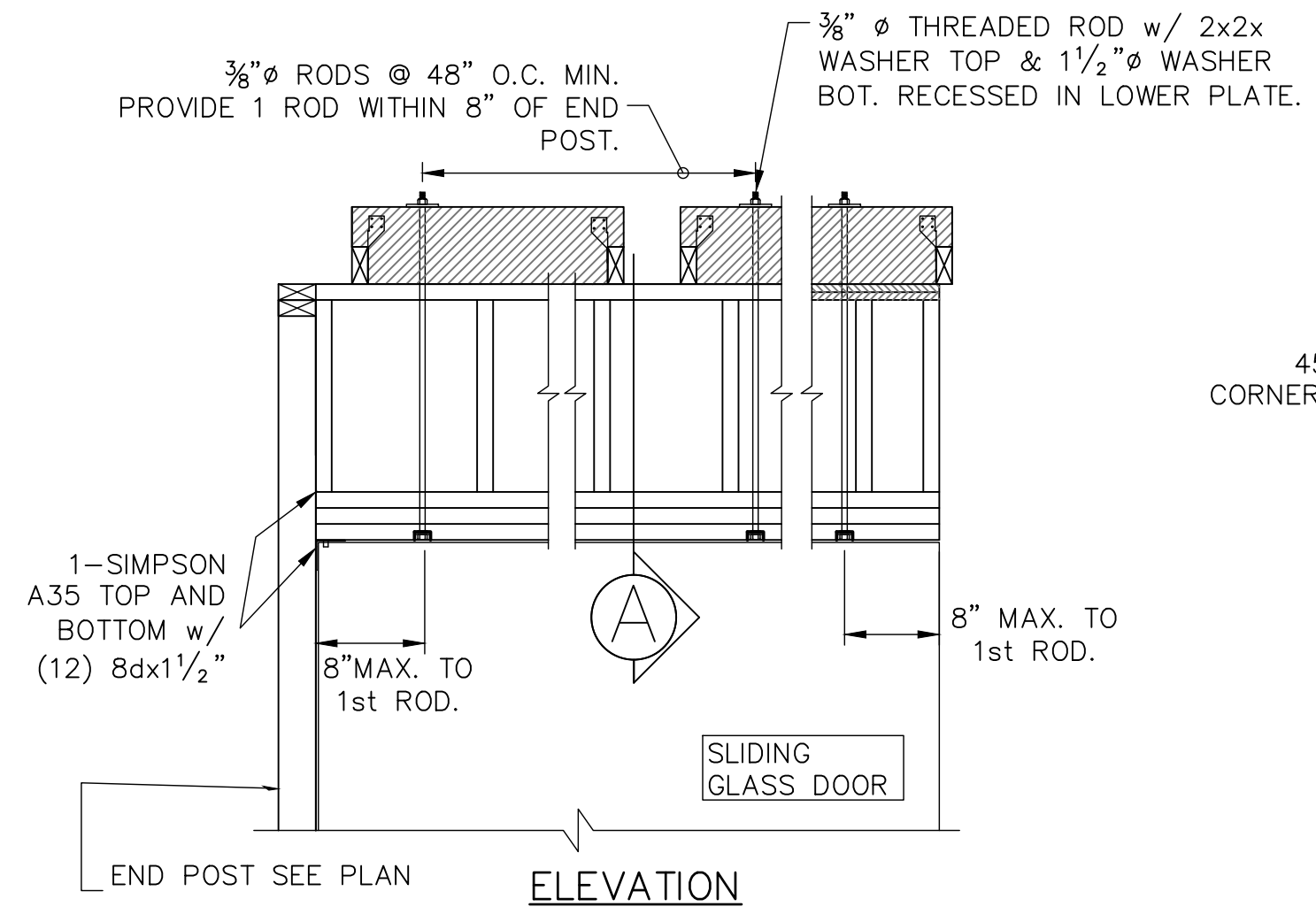
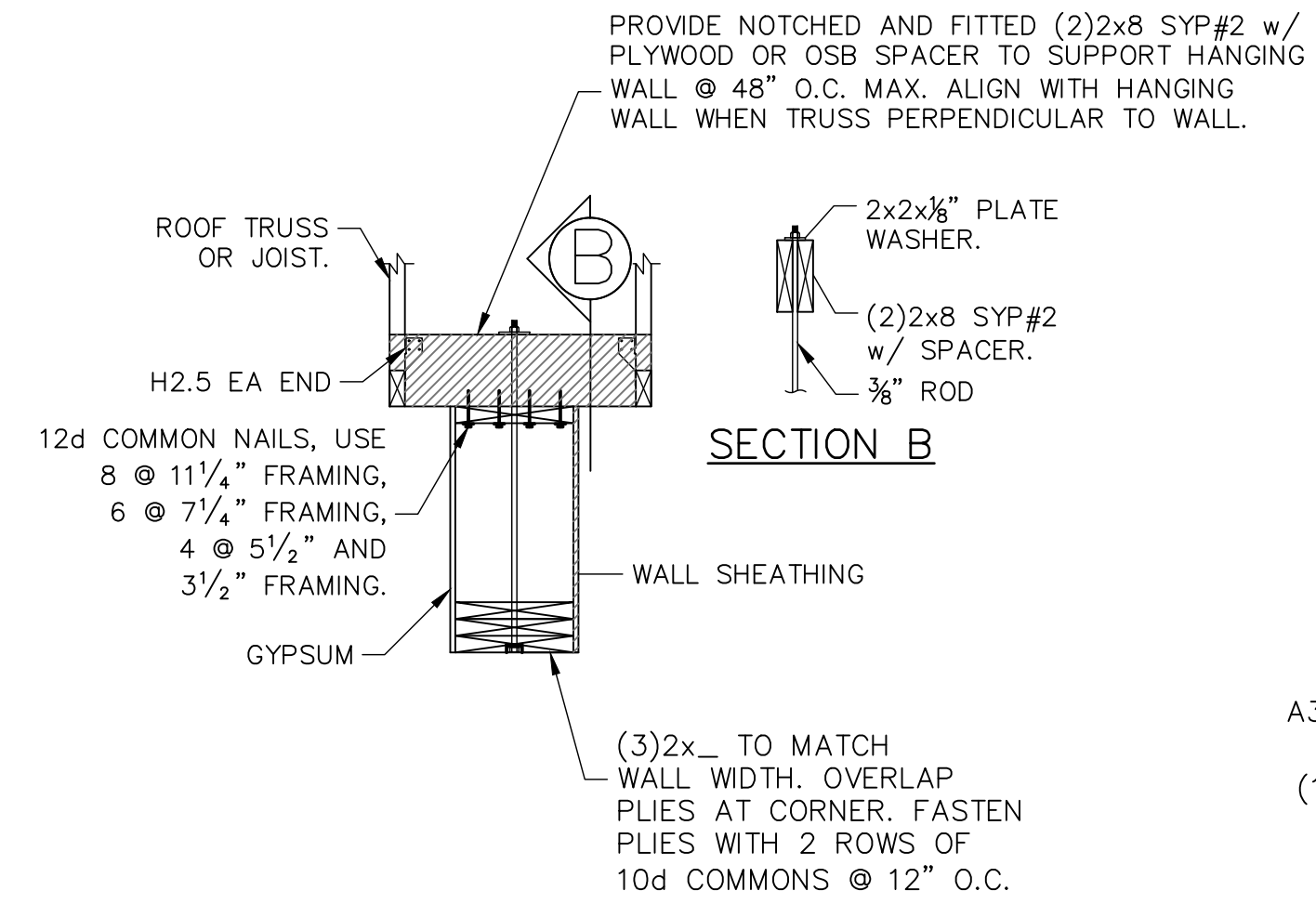
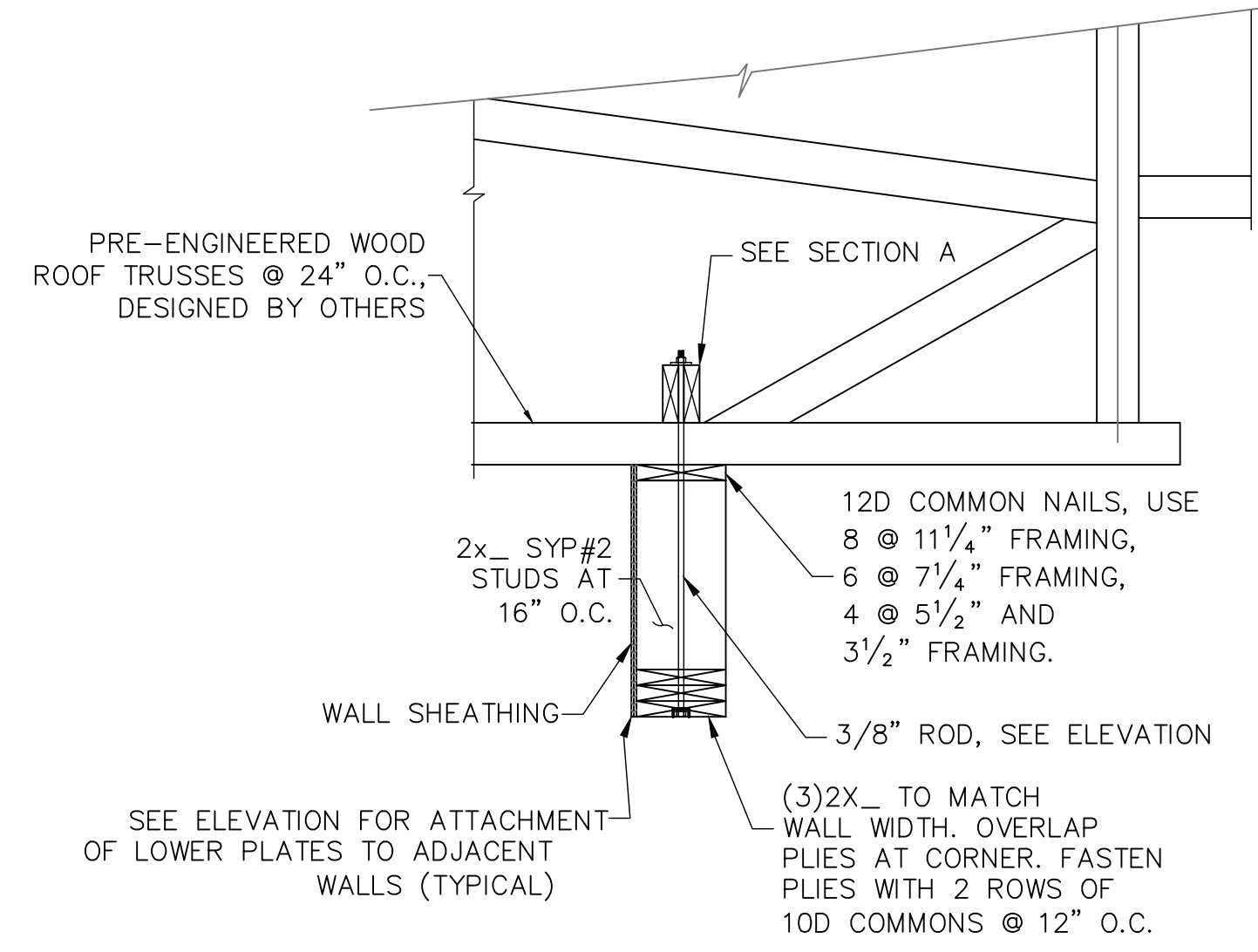

1 SLIDING GLASS DOOR HEADER FRAMING
S2.0 SCALE: N.T.S.

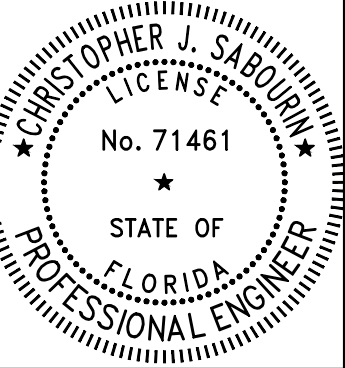

08.01.23
Christopher J Sabourin
FL PE#71461

SABO
STRUCTURAL
ENGINEERING
CA#32529
235 9TH AVE N
JAX BEACH, FL 32250
904-712-5750
CHRIS@SABOENG.COM

PLAN NAME
BZEC MCKINZEY
SSE No.
23-0385

ISSUE	DATE
PERMIT	08.01.23
REVISIONS	DATE

STRUCTURAL ENGINEERING FOR
MCKINZEY RESIDENCE

FIELD ALTERATION
CONTRACTOR SHALL CONTACT SABO STRUCTURAL ENGINEERING PRIOR TO MAKING ANY STRUCTURAL FIELD MODIFICATIONS WHICH MAY VARY FROM THE INTENT OF THE ORIGINAL CONSTRUCTION DOCUMENTS. ANY FIELD ALTERATIONS MADE PRIOR TO BEING APPROVED BY CHRISTOPHER SABOURIN MAY RESULT IN ADDITIONAL ENGINEERING OR INSPECTION FEES.

SCALING
DO NOT SCALE DIMENSIONS FROM THESE DRAWINGS. IF A DIMENSION IS UNCLEAR REFER TO THE ARCHITECTURAL DRAWINGS OR CONTACT THE E.O.R.

MISC
DETAILS

SHEET
S2.0
SHEET 7 OF 7