

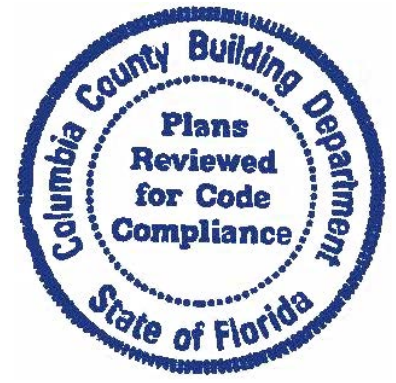

A Groundworks Company



Customer Name:

Judy Glenn

Customer Address:

367 Southwest Kayla Ct, Ft. White, FL 32038

Customer Number:

#186130

To Whom It May Concern:

As part of the permit application for structural repairs, **Alpha Foundations, a Groundworks Company**, is providing engineering commentary relative to the proposed installation of foundation piers for the above-referenced project. Alpha Foundations proposes installing 7 foundation piers at this property. Detailed information about the product and existing building structure are outlined in the attached report.

The purpose of foundation piers will be to stabilize the existing foundation system by providing support to areas that are experiencing distress, and prevent further foundation settlement. With the exception of localized excavation required for the installation of the foundation piers, excavation adjacent to the footing will not be performed.

A log of installed locations, depths, and readings of the piers will be recorded. After completion of the installation of the foundation support system, if requested by the building official, we will evaluate and prepare a letter of completion for permit closeout.

The commentary provided herein is intended to provide guidance during the planning and installation phases of the project. The design follows ordinary engineering practice in the locality of the project and meets requirements of the current **Florida Building Code 2023 8th Edition**. Additional commentary is provided in the "General Commentary" section of this report.

Please feel free to contact us if you have any questions or if we can be of any further assistance.

Respectfully,



This item has been digitally signed and sealed by Timothy D. Triplett, P.E. on the date adjacent to the seal. Printed copies of this document are not considered signed and sealed and the signature must be verified on any electronic copies.
2024.05.08 21:06:45 -04'00'

5/8/2024

TIMOTHY D. TRIPLETT, P.E.
SENIOR ENGINEER
TIM.TRIPLETT@GROUNDWORKS.COM
GROUNDWORKS COMPANIES, LLC

ATTACHMENTS:

**ENGINEERING REPORT
DESIGN CALCULATIONS
GENERAL COMMENTARY
LOCATION/SITE PLAN**

ENGINEERING REPORT FOR FOUNDATION STABILIZATION

BUILDING DEPT.:

REFERENCE CODE:

DATE:

PROJECT:
ADDRESS:
CUSTOMER #:

INSPECTOR:
INSPECTION DATE:



OVERVIEW:

As requested by the owner/representative of the above referenced project (client), the field inspector visited the project and performed a visual inspection of readily accessible foundation areas (walls and piers) and associated structural framing elements. Unless noted below, destructive testing and evaluation was not performed. Based on this inspection, the field inspector and the client agreed to the following "Scope-Of-Work".

SCOPE-OF-WORK: [SEE PRODUCT DETAILS - ATTACHED]

SCOPE-OF-WORK: [SEE PRODUCT DETAILS - ATTACHED]

PUSH PIER QUANTITY: **PUSH PIER SPACING (Typ.):** [±12" ALLOWABLE]

HELICAL PIER QUANTITY: **HELICAL PIER SPACING (Typ.):** [±12" ALLOWABLE]

GENERAL ISSUE:

PROP. SOLUTION:

EXISTING STRUCTURE DETAILS:

- **Classification:**
- **Stories:**
- **Construction Type:**
- **Exterior:**
- **Foundation Type:**
- **Wall Design Loads (Push):** Uniform Wall Load: plf [Based on Typical FBC Load Tables]
- **Wall Design Loads (Helical):** Uniform Wall Load: plf [Based on Typical FBC Load Tables]

SOIL CONDITIONS:

- **Assumed Allowable Bearing Capacity:** psf Per Referenced Code Above



This item has been digitally signed and sealed by Timothy D. Triplett, P.E. on the date adjacent to the seal. Printed copies of this document are not considered signed and sealed and the signature must be verified on any electronic copies.
 2024.05.08 21:06:55 -04'00'

DESIGN CALCULATIONS AND SUMMARY



BUILDING DEPT:	Columbia County Building Department
PROJECT:	Judy Glenn
ADDRESS:	367 Southwest Kayla Ct, Ft. White, FL 32038
DATE:	May 8, 2024

DESIGN CALCULATIONS:

- Based on **load criteria** and building characteristics outlined in the front page of this report, assume a **support** load of: 1,500 plf
- Helical Piers Design Spacing: 7 feet Calculation for additional 12" to allow for field adjustments; See plan for proposed pier spacing.
- Using the **support** load and design pier spacing indicated above, the load on each pier will be:
PIER LOAD = Support Load x Spacing = 10,500 lbs **DESIGN ACCEPTABLE** [SEE NOTE 1 BELOW]
PIER LOAD LESS THAN ALLOWABLE LOAD OF 21,100 LBS
- Minimum Installation Torque: 2,334 ft-lbs [SEE NOTE 2 BELOW]
- Minimum Installation Hydraulic Pressure: 900 psi [Based on Digga MM-10, use attached tables for additional drive heads]

DESIGN COMMENTS:

NOTE 1: The pier load is less than the "Average" allowable load per pier; Factor of Safety (FS) exceeds 2. Refer to the Product Evaluation Report for additional information on the allowable system capacity ratings.

NOTE 2: Contractor shall not exceed maximum recommended installation torque outlined in the Product Evaluation Report. See attached "Groundworks Helical Pier Drive Head Pressure vs Torque Tables" for PSI to Torque conversion based on

Helical Pier/Bracket Detail (Typ.)

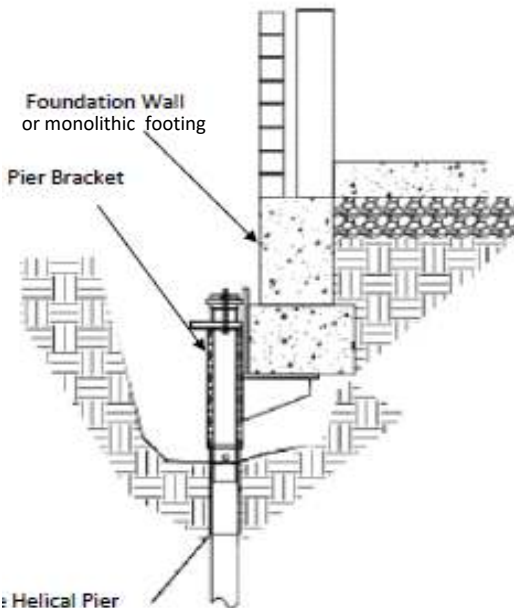

This item has been digitally signed and sealed by Timothy D. Triplett, P.E. on the date adjacent to the seal. Printed copies of this document are not considered signed and sealed and the signature must be verified on any electronic copies.
2024.05.08 21:07:04 -04'00'

*see attached Product Evaluation Report for additional details and specifications

COMMENTARY & LIMITATIONS



BUILDING DEPT:	Columbia County Building Department
PROJECT:	Judy Glenn
ADDRESS:	367 Southwest Kayla Ct, Ft. White, FL 32038
DATE:	May 8, 2024

GENERAL COMMENTARY

The recommendations provided herein are based on our understanding of the project and subsurface characteristics at the time of this report. If differing project conditions are encountered, field personnel shall notify Engineering Department immediately for resolution. Final pier type and location may be altered at engineers discretion based on field conditions.

Unless determined by a site-specific soil boring and laboratory soils analysis, the bearing capacity (net allowable soil pressure) referenced in the first page of this report is based on our experience with soils in the project area as well as the "Presumptive Load-Bearing Values" as outlined in the referenced version of the FBC/IRC. Existing residential structures may be covered under the latest FBC Residential R301.3 and/or IRC Any perimeter pier may be installed on the interior or exterior of the structure at the discretion of the Contractor. It should be noted that subsurface conditions can vary across the site due to natural occurrence or because of previous construction, clearing, or cut/fill grading operations.

LIMITATIONS

The information presented in this report is provided as support to proposed pier installation as outlined in the previous pages. This report does not represent commentary on causation of foundation or structural damage (flood, wind, ground subsidence or heave, etc.). Any additional work shall be considered beyond the scope of these analyses.

FOUNDATION PIER PRODUCT REFERENCES:

- SettleStop Helical Pier Groundworks Product Evaluation Report #2001

Additional Documents:



This item has been digitally signed and sealed by Timothy D. Triplett, P.E. on the date adjacent to the seal. Printed copies of this document are not considered signed and sealed and the signature must be verified on any electronic copies.
2024.05.08 21:07:11 -04'00'

5/8/2024

LOCATION / LAYOUT PLAN / NOTES

BUILDING DEPT.:
PROJECT:
ADDRESS:
DATE:

Columbia County Building Department
 Judy Glenn
 367 Southwest Kayla Ct, Ft. White, FL 32038
 May 8, 2024

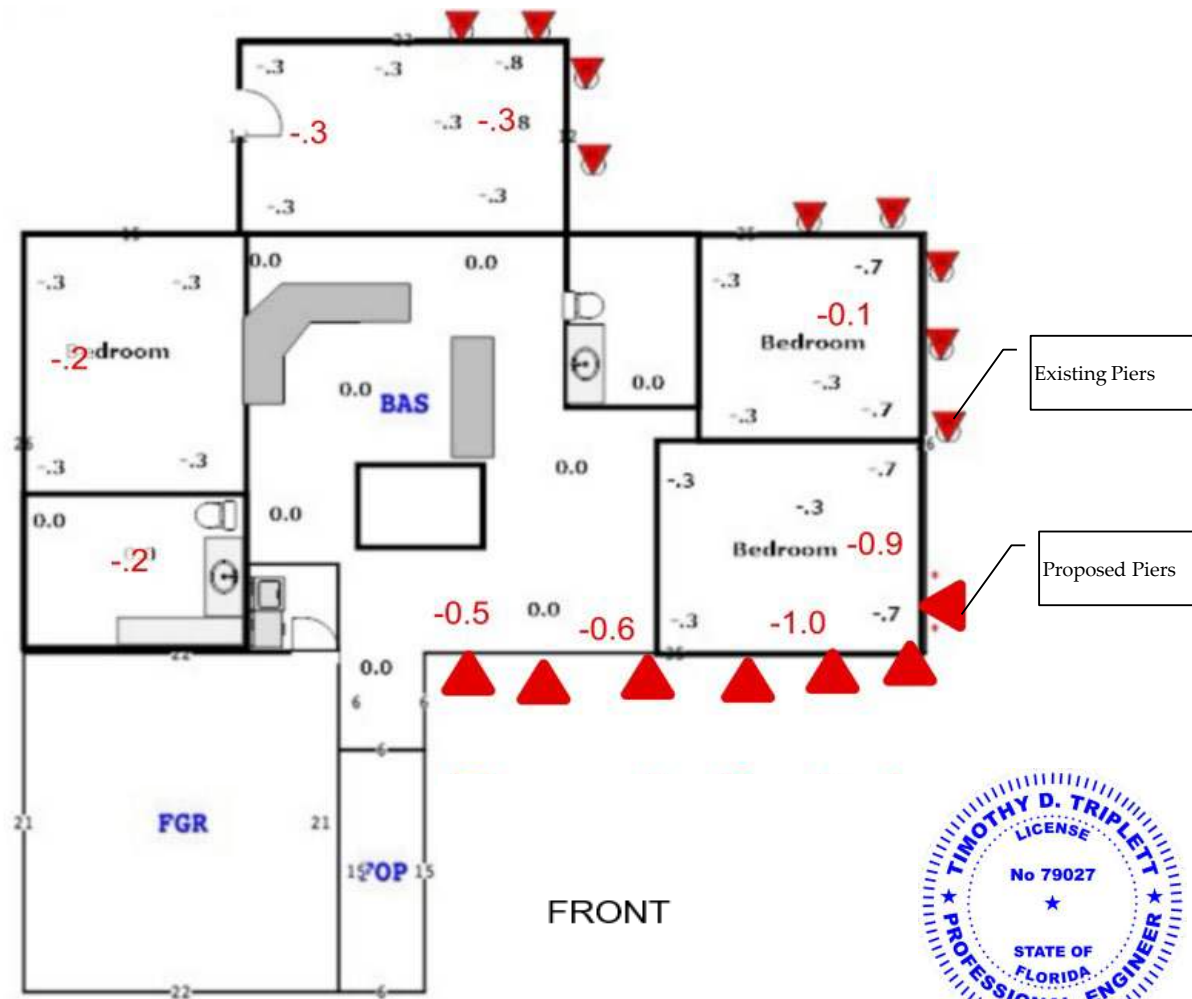

 Helical Pier
 Maximum Spacing 6' +/- 1'



This item has been digitally signed and sealed by Timothy D. Triplett, P.E. on the date adjacent to the seal. Printed copies of this document are not considered signed and sealed and the signature must be verified on any electronic copies.
 2024.05.08 21:07:20 -04'00'

SettleStop Helical Pier System**1. General Information**

The SettleStop Helical Pier System is a steel foundation support system consisting of a steel shaft (helical screw) and bracket. The bracket is used to transfer compression loads from existing foundations/structures to the shaft. The shaft and helical plates in turn transfer the loads to suitable soil bearing strata below. The intended use of this product is for residential structures governed by the International Residential Code (IRC).

2. Product Description

The SettleStop Helical Pier System consists of steel shafts connected to brackets that support existing foundations/structures. The steel shaft assemblies consist of a lead section, fitted with helical plates, and one or more extension sections. The lead section is screwed into the ground by application of torsion using a pressure-driven drive head. Extensions are connected (bolted) to the lead section and to each other and the assembly continues to be screwed into the soil until reaching the required load capacity. Capacities are determined by correlation to the torque required to continue screwing the assembly. The bracket is then connected to the top of the shaft assembly and fitted below the structure's foundation to provide support. Threaded rods are used to bring the bracket into contact with the bottom of the footing to ensure load transfer from the structure onto the bracket and shaft assembly.

3. Component Description

- 3.1. Lead Section and Helical Plates:** The lead shaft has a 2-7/8" outside diameter (73.0 mm) and has a nominal thickness of 0.217" (5.5 mm). The tubing conforms to ASTM A500 Steel, Grade C with a minimum yield strength of 46 ksi (315 MPa) and a minimum tensile strength of 62 ksi (425 MPa). The leading end of the lead section is fitted with either one or two helical-shaped plates which are welded to the shaft and advance the assembly into the soil as it is rotated. The plates are either 12" (304.8 mm) or 10" (254 mm) in diameter and have a nominal thickness of 3/8" (9.53 mm). The plates conform to ASTM A36 Steel, with a minimum yield strength of 36 ksi (248 MPa) and a minimum tensile strength of 58 ksi (400 MPa). The top end of the shaft has two 7/8" (22.23 mm) diameter holes which are used for connecting the lead sections to the first extension. The lead shaft and helical plates are hot dip galvanized in accordance with ASTM A153 / ASTM A123. See Figures A-1 and A-2.
- 3.2. Extension and Coupler:** The extensions are made of the same tubing as the lead section. The top end of the extension has two 7/8" (22.23 mm) diameter holes which are used for connecting it to any subsequent extensions. The bottom end of the extension is fitted with a coupler sleeve, which is fillet and plug welded to the shaft. The coupler has a 3-1/2" outside diameter (89.0 mm) and has a nominal thickness of 0.254" (6.45 mm). The coupler material conforms to ASTM A500 Steel, Grade C with a minimum yield strength of 46 ksi (315 MPa) and a minimum tensile strength of 62 ksi (425 MPa). The extension shaft and couplers are hot dip galvanized in accordance with ASTM A153 / ASTM A123. See Figures A-3 and A-4 for details.
- 3.3. Bracket and Cap Plate:** The bracket is constructed from round structural steel tubing and plates, which are welded together to form the bracket geometry. The L-shaped seat of the bracket consists of bent 3/8" (9.53mm) plate. The plate is 10-1/2" (266.7 mm) and bent into an 8" (203.2 mm) horizontal leg and a 6" (152.4 mm) vertical leg. The vertical leg of the seat is welded to a 3-1/2" outside diameter (89.0 mm) pipe sleeve with nominal 7/32" (5.56 mm) thickness. A 3/4" (19.05 mm) bracket plate is welded near the top of the pipe sleeve and to the seat plate. Two angled gusset plates fabricated using 3/8" (9.53 mm) plate are welded to the underside of the horizontal leg of the seat and to the side of the pipe sleeve. An 8-3/4" (222.25 mm) by 4" (101.6 mm) plate with nominal thickness of 1" (25.4 mm) is provided to complete the bracket assembly. The plate is fitted with a 1/2" (12.7 mm) ring of 3-1/2" outside diameter tubing (89.0 mm) to help align and center the plate at the top of the shaft assembly. The cap plate has two 7/8" (22.23 mm) diameter holes, which match holes in the bracket plate. The holes are used to install two 3/4" (19.05 mm) all-thread rods and matching nuts. The rods make the load transfer from the bracket seat plate, through the top plate, and onto the shaft assembly. Plate components for the bracket assembly conform to ASTM A36 Steel, with a minimum yield strength of 36 ksi (248 MPa) and a minimum tensile strength of 58 ksi (400 MPa). The pipe sleeve material conforms to ASTM A500 Steel, Grade C with a minimum yield strength of 46 ksi (315 MPa) and a minimum tensile strength of 62 ksi (425 MPa). The bracket assembly is hot dip galvanized in accordance with ASTM A153 / ASTM A123. See Figures A-5, A-6, and A-7 for details.
- 3.4. Lifting Rods, Bolts, and Nuts:** The heavy hex bolts used for making coupler connections between lead section and extension sections or between extension sections are 4-1/2" long, 3/4" diameter bolts with matching nuts. The bolts shall be SAE J429, Grade 8, ASTM A490, or ASTM A325. The bolts and nuts must be galvanized or zinc coated. The lifting rods shall be 3/4" all-thread rods meeting ASTM A193, Grade B7, or 3/4" 4.5 coil rods meeting ASTM A108, Grade 1045. The lifting rods and matching nuts must be zinc coated or hot dip galvanized.

SettleStop Helical Pier System

4. Code Compliance

The strength design of the SettleStop Helical Pier System complies with Section 301.1.3 of the 2015, 2018, and 2021 IRC by designing the components in accordance with accepted engineering practice and the applicable material codes (ANSI/AISC 360 – Specification for Structural Steel Buildings).

5. Design Basis and Capacity

The capacities of the various components of the helical pier system are determined by a combination of analysis, computer modeling, and full-scale testing. Design methodologies were selected in accordance with ICC AC358, 2020 Edition, “Acceptance Criteria for Helical Pile Systems and Devices”. Based on the guidance provided in ICC AC358, the capacities of the four primary structural elements of the helical pile system. The four primary structural elements are the Bracket Capacity (P1), Shaft Capacity (P2), Helix Capacity (P3), and Soil Capacity (P4).

The Bracket Capacity (P1) was analyzed using finite element modeling to determine the ultimate and allowable compressive load. The model results were compared to full-scale bracket load testing previously performed (by others) to validate the results.

The Shaft Capacity (P2) was calculated for various unbraced length conditions. Calculations were performed in accordance with ANSI/AISC 360-22, “Specifications for Structural Steel Buildings”.

The Helix Capacity (P3) was determined by performing full-scale testing. Compressive and torsional loads were imposed to determine the corresponding capacities for the helixes and their welds to the shaft.

The Soil Capacity (P4) was determined by correlation of the maximum allowable torque (determined in P3 testing described above). ICC AC358 Section 3.13.1.1 and Table 3 provide torque correlation values for various geometries of helical pile systems, including the one covered in this report.

Details of the calculations, analysis, and testing performed are documented in the Groundworks report titled “NSI Helical Piers Testing and Analysis Report”.

5.1. Design Capacities

5.1.1. Bracket Capacity

Table 1 provides the allowable compressive capacity for the bracket assembly. It should be noted that the bracket is not intended to resist tension or lateral loading (shear).

TABLE 1 – Allowable Capacities for Bracket

Bracket Use	Allowable Capacities
	Compression, (kips)
Repair Bracket	23.65

5.1.2. Shaft Assembly Capacity

Table 2 provides the allowable capacities for the shaft assembly. The allowable compressive capacity shall be taken as the minimum of the allowable shaft capacity (considering the applicable unbraced length and coupling configuration) and the compressive capacity achieved at the maximum allowable installation torque. It should be noted that the shaft assembly has not been analyzed to resist tension or lateral loading (shear).

TABLE 2 – Allowable Capacities and Recommended Maximum Installation Torque for Shaft and Helix

Helical Pile Shaft OD-thickness, inch	Allowable Axial Capacity						Recommended Capacity-Torque Ratio, $K_t(ft^{-1})$	Recommended Max-Installation Torque, $T(ft-lbs.)$	Ultimate Load at Max Torque Capacity, $O_u=TK_t$ (kips)	Allowable Load at Max Torque Capacity, (kips) $Q_u/2=Q_a$	
	Compression, (kips)				Tension, (kips)	Shear, (kips)					Bending, (ft-k)
	Unbraced Length, L_u (ft)	$kL_u=0$	$kL_u=5$	$kL_u=10$							
2.875-0.217	0 Couplings-no eccentricity	39.4	31.75	16.5	-	-	-	9	4,693	42.2	21.1
	1 Coupling	39.4	24.9	12.0							
	2 Couplings	39.4	20.5	9.4							

5.2. Items Requiring Verification

The following items are related to the use and determination of code compliance for the SettleStop Helical Pier system, but are not within the scope of this evaluation report:

- 5.2.1. Determination of foundation loads imposed on the helical pier assembly.
- 5.2.2. Determination of the ability for the foundation wall/footing to adequately span distance between helical piers.

6. Installation and Use

Where required by the code official, engineering calculations and construction documents consistent with this report must be submitted to the code official for approval. The documents must address the items in Section 5.2, consistent with the requirements of this report. The documents must be prepared by a registered design professional where required by the statutes of the jurisdiction in which the project is to be constructed. Installation of the SettleStop Helical Pier System must comply with this report, any published installation instructions, and the approved plans. Some general installation details are shown in Appendix B.

- 6.1. The retrofit bracket and helical pier lead/extension components shall be verified to be those described in Sections 3.1, 3.2, and 3.3. The lifting rods, coupler bolts, and nuts intended to be used for installation shall be verified to meet the requirements described in Section 3.4.
- 6.2. The retrofit bracket must be installed flush to the side and bottom of foundation wall to ensure full bearing of the foundation wall on the base plate.
- 6.3. The lead section and extension(s) shall be installed as close to vertical as practical.
- 6.4. The helical piers shall be driven to the minimum specified torque value provided in the project-specific engineering plans.
- 6.5. Drive-head specific torque correlation charts should be used to determine proper driving pressure required to achieve specified torque and corresponding helical pier capacity.
- 6.6. The crew shall furnish field logs indicating the drive head(s) used, driving pressures, and number of extensions/total length for each helical pier.

APPENDIX A

Component Details

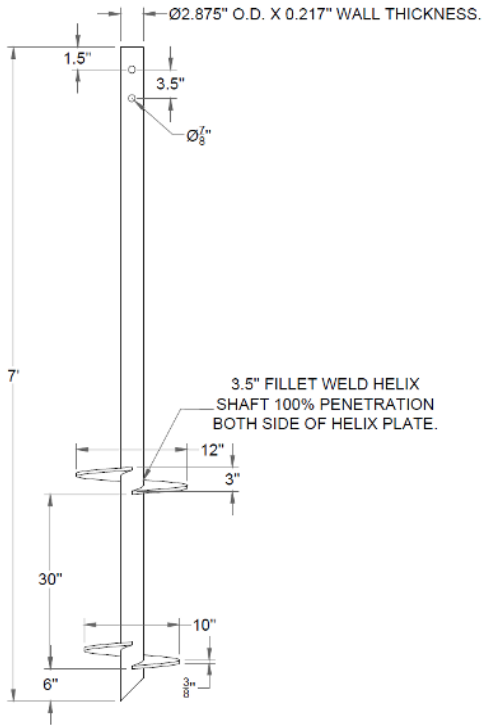

**FIGURE A-1 – LEAD SECTION
(12" AND 10" DIAMETER HELIX PLATES)**

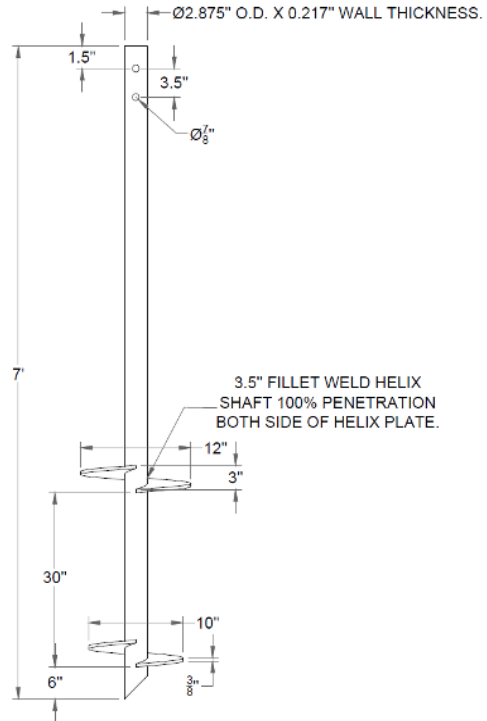

**FIGURE A-2 – LEAD SECTION
(12" DIAMETER HELIX PLATE)**

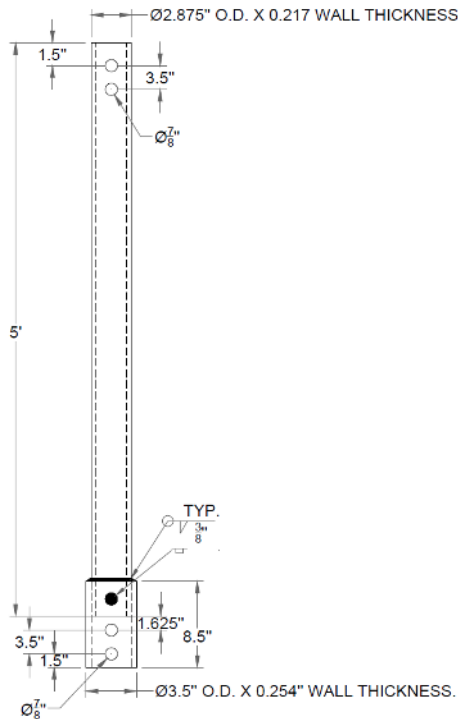

**FIGURE A-3 – EXTENSION AND
COUPLER (5' LENGTH)**

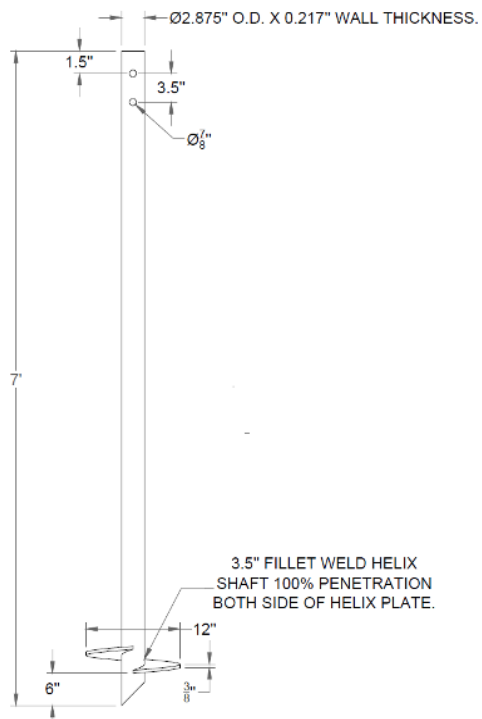

**FIGURE A-4 – EXTENSION AND
COUPLER (7' LENGTH)**

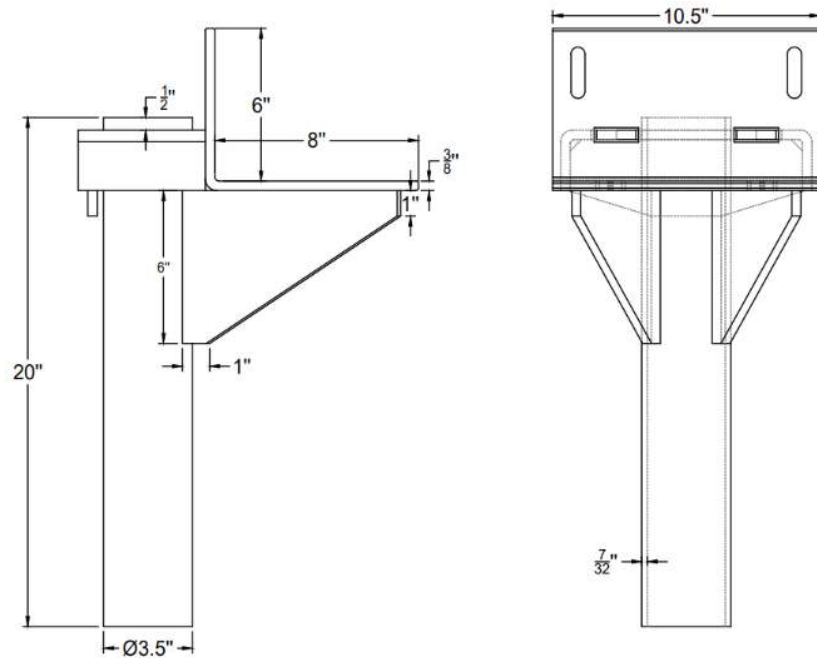

FIGURE A-5 – BRACKET (FRONT AND SIDE VIEW)

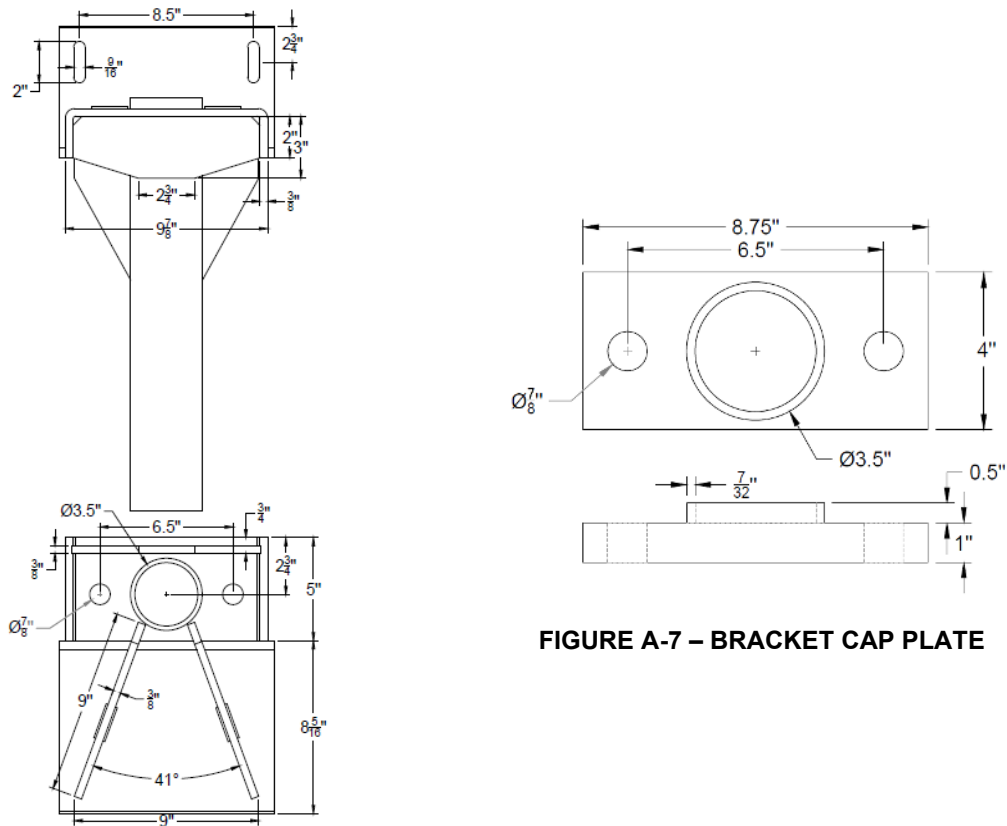
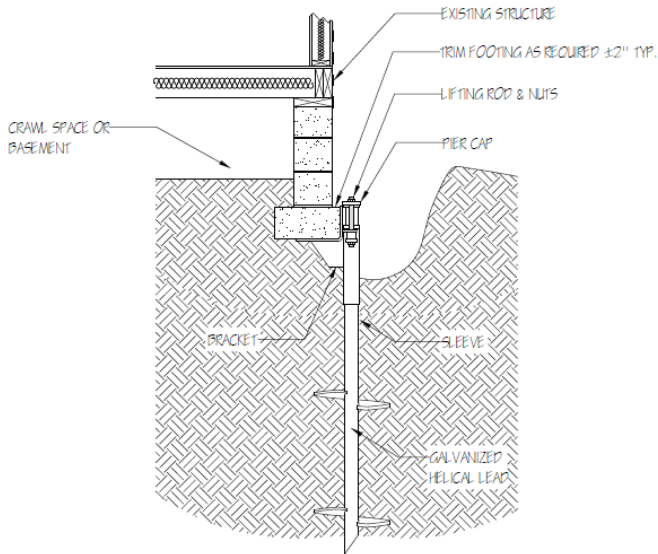

FIGURE A-6 – BRACKET
(BACK AND TOP VIEW)

FIGURE A-7 – BRACKET CAP PLATE

APPENDIX B
Installation Details



A
5001 HELICAL DETAIL
1/2" = 1' - 0"

**FIGURE B-1 – HELICAL PIER INSTALLATION
(BASEMENT OR CRAWLSPACE RESIDENCE)**

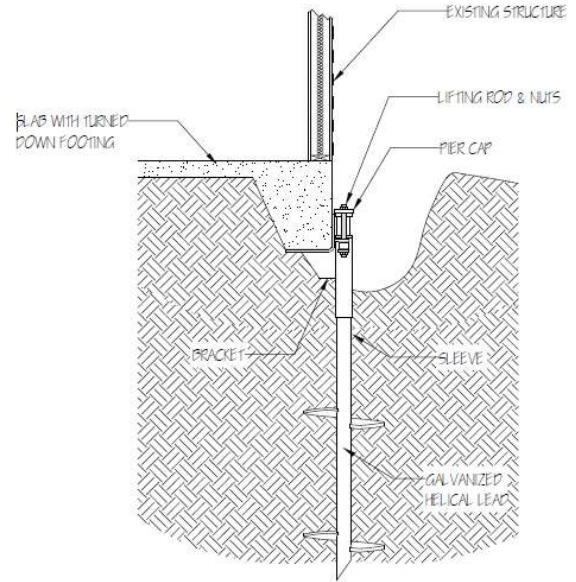

B
5001 HELICAL DETAIL
1/2" = 1' - 0"

**FIGURE B-2 – HELICAL PIER INSTALLATION
(SLAB-ON-GRADE RESIDENCE)**



Helical Pier Drive Head Pressure vs Torque Tables

Differential Pressure (psi)	Pro-Dig					Digga		Pengo		Eskridge				
	L6K5 with bail	L6K5 no bail	X7K5	X8K5C	X9K5	7ALS - Low Pressure	MM-10	RS-6	RS-7	5016 (5k)	7848 (12k)		7551 (20k)	
											Low Torque	High Torque	Low Torque	High Torque
500	1,267	1,267	1,274	1,414	1,611	1,194	1,746	1,349	1,502	1,522	686	2,508	1,432	3,493
600	1,520	1,520	1,529	1,696	1,933	1,433	2,095	1,619	1,802	1,826	826	3,020	1,734	4,228
700	1,774	1,774	1,784	1,979	2,255	1,672	2,444	1,889	2,103	2,131	967	3,531	2,036	4,963
800	2,027	2,027	2,038	2,262	2,577	1,911	2,793	2,159	2,403	2,435	1,107	4,043	2,337	5,699
900	2,281	2,281	2,293	2,544	2,899	2,150	3,142	2,429	2,704	2,740	1,247	4,555	2,639	6,434
1000	2,534	2,534	2,548	2,827	3,221	2,389	3,493	2,699	3,004	3,044	1,387	5,067	2,940	7,169
1100	2,787	2,787	2,803	3,110	3,543	2,628	3,842	2,969	3,305	3,348	1,527	5,579	3,242	7,905
1200	3,041	3,041	3,058	3,392	3,865	2,866	4,191	3,240	3,606	3,653	1,667	6,090	3,543	8,640
1300	3,294	3,294	3,312	3,675	4,187	3,105	4,540	3,510	3,906	3,957	1,807	6,602	3,845	9,375
1400	3,548	3,548	3,567	3,958	4,509	3,344	4,889	3,780	4,207	4,262	1,947	7,114	4,147	10,111
1500	3,801	3,801	3,822	4,241	4,832	3,583	5,239	4,050	4,507	4,566	2,087	7,626	4,448	10,846
1600	4,054	4,054	4,077	4,523	5,154	3,822	5,588	4,320	4,808	4,870	2,227	8,137	4,750	11,581
1700	4,308	4,308	4,332	4,806	5,476	4,061	5,937	4,590	5,108	5,175	2,367	8,649	5,051	12,317
1800	4,561	4,561	4,586	5,089	5,798	4,299	6,286	4,860	5,409		2,507	9,161	5,353	13,052
1900	4,815	4,815	4,841	5,371	6,120	4,538	6,636	5,130	5,709		2,647	9,673	5,654	13,787
2000	5,068	5,068	5,096	5,654	6,442	4,777	6,985	5,400	6,010		2,787	10,185	5,956	14,523
2100	5,321	5,321	5,351	5,937	6,764	5,016	7,334	5,670	6,310		2,928	10,696	6,257	15,258
2200	5,575	5,575	5,606	6,219	7,086	5,255	7,684	5,940	6,611		3,068	11,208	6,559	15,993
2300	5,828	5,828	5,860	6,502	7,408	5,494	8,033	6,210	6,911		3,208	11,720	6,861	16,729
2400	6,082	6,082	6,115	6,785	7,730	5,732	8,383	6,480	7,212		3,348	12,232	7,162	17,464
2500	6,335	6,335	6,370	7,068	8,053	5,971	8,732	6,750	7,512				7,464	18,199
2600			6,625	7,350	8,375	6,210	9,081						7,765	18,935
2700			6,880	7,633	8,697	6,449	9,430						8,067	19,670
2800			7,134	7,916	9,019	6,688	9,779						8,218	20,038
2900			7,389	8,198	9,341	6,927	10,129							
3000			7,644	8,481	9,663	7,166	10,478							
Hex size	2"	2"	2.5"		2.5"	2.5"	2.5"	2"	2"	2"	2.5"		3"	
Max PSI	2500psi	2500psi	3000psi	3000psi	3000psi	3000psi	3000psi	2500psi	2500psi	2400psi	2400psi		2750psi	
GPM	5-16 gpm	5-16 gpm	10-35 gpm	4-25 gpm	10-35 gpm		7-12 gpm	10-25 gpm	10-25 gpm	25 gpm	40 gpm		40 gpm	

Notes:

- 1 Values in this table are expressed in foot-pounds
- 2 = Max torque for SettleStop 2.875 helical pier
- 3 = Max torque for Grip-Tite 2.875 helical pier
- 4 Helical pier wall thickness = 0.203"



This item has been digitally signed and sealed by Timothy D. Triplett, P.E. on the date adjacent to the seal. Printed copies of this document are not considered signed and sealed and the signature must be verified on any electronic copies.
2024.05.08 21:07:30 -04'00'