

COLUMBIA COUNTY Property Appraiser

Parcel 17-3S-16-02168-110

Owners

AROCHO WILFREDO
AROCHO YOLANDA
861 NW BLACKBERRY CIR
LAKE CITY, FL 32055

GIS

Pictometry



Parcel Summary

Location	861 NW BLACKBERRY CIR
Use Code	0100: SINGLE FAMILY
Tax District	3: COUNTY
Acreage	4.470
Township	3S
Range	16
Subdivision	DIST 3
Exemptions	01: HOMESTEAD (196.031a&b) (100%)

3157
Rd
Assessor

Legal Description

LOT 10 BLACKBERRY FARMS S/D.

WD 1036-1438, WD 1141-2036 &
WD 1200-2469 & WD 1237-2305

Working Values

	2026
Total Building	\$550,793
Total Extra Features	\$29,732
Total Market Land	\$67,050
Total Ag Land	\$0

	2026
Total Market	\$647,575
Total Assessed	\$432,701
Total Exempt	\$51,411
Total Taxable	\$381,290
SOH Diff	\$214,874

Value History

	2025	2024	2023	2022	2021	2020
Total Building	\$557,429	\$528,821	\$489,148	\$447,282	\$419,736	\$352,742
Total Extra Features	\$30,497	\$31,516	\$32,280	\$30,460	\$21,958	\$22,512
Total Market Land	\$61,462	\$55,875	\$55,875	\$55,875	\$44,700	\$44,314
Total Ag Land	\$0	\$0	\$0	\$0	\$0	\$0
Total Market	\$649,388	\$616,212	\$577,303	\$533,617	\$486,394	\$419,568
Total Assessed	\$421,325	\$409,451	\$397,525	\$385,947	\$374,706	\$369,533
Total Exempt	\$50,722	\$50,000	\$50,000	\$50,000	\$50,000	\$50,000
Total Taxable	\$370,603	\$359,451	\$347,525	\$335,947	\$324,706	\$319,533
SOH Diff	\$228,063	\$206,761	\$179,778	\$147,670	\$111,688	\$50,035

Document/Transfer/Sales History

Instrument / Official Record	Date	Q/U	Reason	Type	V/I	Sale Price	Ownership
WD 1237/2305	2012-06-22	U	37	WARRANTY DEED	Improved	\$325,000	Grantor: CHARLES & LANE BRISCOE Grantee: WILFREDO & YOLANDA AROCHO
WD 1200/2469	2010-08-31	Q	01	WARRANTY DEED	Improved	\$406,000	Grantor: JOHN A & KAREN L DEARDORFF Grantee: CHARLES & LANE BRISCOE
WD 1141/2036	2008-01-28	Q		WARRANTY DEED	Vacant	\$95,000	Grantor: JAMES A & JUANA JO LYTTE Grantee: JOHN A & KAREN L DEARDORFF
WD 1036/1438	2005-01-25	Q		WARRANTY DEED	Vacant	\$119,900	Grantor: DANIEL CRAPPS Grantee: JAMES A & JUANA JO LYTTE

Buildings

Building # 1, Section # 1, 348779, SFR

Type	Style	Heated Sq Ft	Repl Cost New	YrBlt	Year Eff	Gross Area	Other % Dpr	Normal % Dpr	% Cond	Value
0100	01	4009	\$663,606	2008	2008	5,640	0.00%	17.00%	83.00%	\$550,793

Structural Elements

Type	Description	Code	Details
EW	Exterior Wall	32	HARDIE BRD
RS	Roof Structure	03	GABLE/HIP
RC	Roof Cover	03	COMP SHNGL
IW	Interior Wall	05	DRYWALL
IF	Interior Flooring	14	CARPET
IF	Interior Flooring	12	HARDWOOD
AC	Air Conditioning	03	CENTRAL
HT	Heating Type	04	AIR DUCTED
BDR	Bedrooms	5.00	
BTH	Bathrooms	4.00	
FR	Frame	02	WOOD FRAME
STR	Stories	2.	2.
AR	Architectural Type	05	CONV

Sub Areas

Type	Gross Area	Percent of Base	Adjusted Area
BAS	2,041	100%	2,041
FGR	942	55%	518
FOP	28	30%	8
FSP	661	40%	264
FUS	1,968	100%	1,968

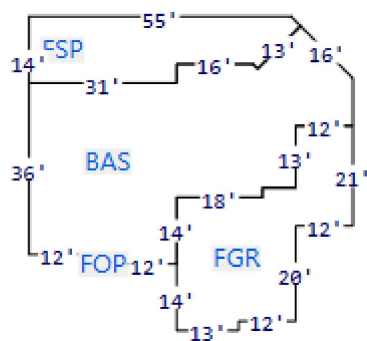
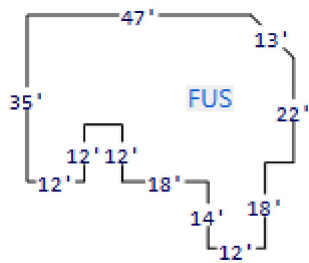

Extra Features

Code	Description	Length	Width	Units	Unit Price	AYB	% Good Condition	Final Value
0180	FPLC 1STRY			1.00	\$2,000.00	2008	100%	\$2,000
0280	POOL R/CON	13	28	364.00	\$70.00	2008	58%	\$14,778
0282	POOL ENCL	28	44	1232.00	\$15.00	2008	40%	\$7,392
0166	CONC,PAVMT			2781.00	\$2.00	2008	100%	\$5,562

Land Lines

Code	Description	Zone	Front	Depth	Units	Rate/Unit	Acreage	Total Adj	Value
0100	SFR	A-1	.00	.00	4.47	\$12,000.00/AC	4.47	1.25	\$67,050

Personal Property

None

Permits

Date	Permit	Type	Status	Description
Oct 24, 2008	27415	POOL ENCL	COMPLETED	POOL ENCL
Sep 23, 2008	27321	POOL	COMPLETED	POOL
Feb 18, 2008	26746	SFR	COMPLETED	SFR

TRIM Notices

2025
2024
2023

Disclaimer

All parcel data on this page is for use by the Columbia County Assessor for assessment purposes only. The summary data on this page may not be a complete representation of the parcel or of the improvements thereon. Building information, including unit counts and number of permitted units, should be verified with the appropriate building and planning agencies. Zoning information should be verified with the appropriate planning agency. All parcels are reappraised each year. This is a true and accurate copy of the records of the Columbia County Assessor's Office as of June 18, 2026.