

Digitally signed by MICHAEL THOMPSON
Reason: This item has been signed & sealed by Michael A. Thompson on the date adjacent to the seal. Printed copies of this document are not considered signed and sealed and the signature must be verified on any electronic copies.
Date: 2024.12.31 09:21:39 -05'00'

***Plan Types:**

- Screen Room Sun Room Fill In
- Pool Screen/Cage (Non-Removable Screen – Designed to withstand actual Wind Speed)
- Expansion View (Non Standard)
- Car Port Patio Cover
- Pergola
- Swimming Pool (Non Standard)
- Summer Kitchen (Non Standard)
- Other _____



* Standard Non Standard Revision Commercial \$75.00 Rush Fee

* Project Address: 314 SW Arrowbend DR

* City: Lake City FL Date: _____

* Contractor/Company Name: Restoration Specialists
 * Address: 244 NW 9th St
 * City: Ocala
 * Zip Code: 34475
 * Phone/Fax: 352 553 6771
 * Email: jessical532@gmail.com

* Choose One: Mail Pick Up E-File Fed Ex/UPS* _____ # of Copies

Single PDF
 Each Page Separate

*(For FedEx option go to www.aluminumscreendesign.com and provide FedEx/UPS account #)

* Payment: Check Credit Card*

*(For Credit Card option go to www.aluminumscreendesign.com to pay by credit card)

Engineering prepared by:



Engineer: Michael Thompson, MSc, P.E. (P.E. # 47509)
 4401 Vineland Road- Suite A6 Orlando, FL 32811
 Office: 888-607-0747 or 407-734-1470 Cell: 407-721-2292
 Project Manager Paul Thomas 386-479-9504 Fax: 888-923-8181
 Email: aluminumscreendesign@yahoo.com
 Website: www.aluminumscreendesign.com CA#30930

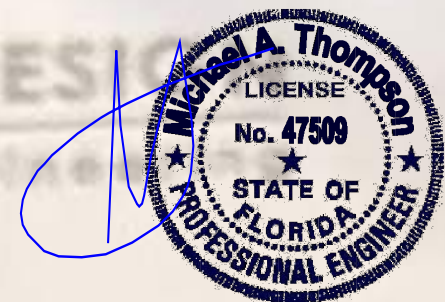

Digitally signed by MICHAEL THOMPSON
 Reason: This item has been signed & sealed by Michael A. Thompson on the date adjacent to the seal. Printed copies of this document are not considered signed and sealed and the signature must be verified on any electronic copies.
 Date: 2024.12.31 09:21:50 -05'00'

* Ultimate Wind Speed (mph): 130 Exposed Category: 6 Risk Category: 1

Screen Room Fill In Sun Room (Window Type Vinyl or Glass)
 Roof Type: Insulated Pan Roof
 Roof Connecting to: Gutter Fascia Block Wall Conventional Wall 4th Wall Riser
 Front Wall: Uprights X Top Plate X Bottom Plate X Chair Rail X
 Side Wall: Uprights X Top Plate X Bottom Plate X Chair Rail X
 Roof Ridge Beam (gable style): Beams X Kick Plate

Pool Screen/Cage :

Roof Type: Dome Gable Mansard/Hip Flat/Slope
 Roof Connecting to: Gutter Fascia Block Wall Conventional Wall Riser
 Roof: Beams 2 X 7 Front Wall: Uprights 2 X 4 Purlin 2 X 2 Chair Rail 2 X 2
 Side Wall: Uprights 2 X 4 Chair Rail 2 X 2
 Expansion View: Beams X Post X Kick Plate

Car Port Patio Cover or Pergola (pergola material Aluminum Wood)
 Roof Type: Insulated Pan Roof None (Pergola Only)
 Roof Connecting to: Gutter Fascia Block Wall Conventional Wall 4th Wall
 Beams X Post X Pergola Purlins X
 Roof Ridge Beam (gable style): Beams X

Swimming Pool Gunite Fiberglass Overall Deck SQ FT

Summer Kitchen

Concrete:

Existing New 4" w/6" Thickened Edge Pier X X
 Ribbon Footer X With # Rebar
 Pavers with Footer X With # Rebar

Other:

Note: In the event that there is a conflict with the design plans and general notes and design standard, the contractor shall utilize the more stringent dimensions and member sizes prior to ordering materials, fabrication and/or construction between the plans and the general notes and design standard.



General Notes & Design Standards (Non-Removable Pool Screen)

The following are general design standards. More stringent design standards may be noted on the plans. In the event of a conflict in plans and/or design standard dimensions and/or member sizes, the contractor must utilize the more stringent dimensions and/or member sizes prior to ordering materials, fabrication and/or construction.

Design Codes:

Florida Building Code 2023 (8th Edition)
Aluminum Design Manual 2020
ASCE 7-22

Design Loads:

Pursuant to FBC Chapters 16 & 20
Ultimate Wind: **-130 MPH** (FBC Table 2002.4)
Risk Category: -See attach site specific plan sheet (FBC Table 1604.5)
Exposure Category: -See attach site specific plan sheet (FBC 1609.4.3)

Additional Load requirements:

Structural members supporting screened enclosures are designed for wind in both of two orthogonal directions using the pressures given in Table 2002.4. Each primary member is also designed for a 300 pound load applied vertically downward along any 1 foot of any member, not occurring simultaneously with wind load. In addition to wind pressures, purlins is also be designed for a 200 pound load applied vertically downward along any 1 foot of any member, not occurring simultaneously with wind load.

Design Basis:

Allowable Stress Design (ASD) = Allowable Strength Design (ASD) divide by safety factor

General Requirements:

Reproductions of contract drawings by contractor in lieu of preparation of shop drawings signifies acceptance of information shown as correct and obligates himself to any expense, real or implied, arising from their use.

A change to the structural drawings due to the acceptance of alternates and/or substitutes is the responsibility of the contractor and must be submitted to the engineer for approval.

The general contractor and each subcontractor shall review the approve construction plans in its entirety and verify all existing conditions prior to the start of any work. All inconsistencies shall be reported to the designer and/or structural engineer, if needed. Should contractor construct the premises in a fashion not consistent with the plans prepared by the designer and/or structural engineer, or in any fashion, change the plans and drawing without the review and approval from the designer and/or structural engineer. Then designer and/or structural engineer shall bear no responsibility or liability for the construction of premises and accuracy of the drawings.

Foundation and Earthwork:

Applicable only when unsuitable soils are encountered.
When unsuitable soils are encountered as specified bearing strata, notify owner's representative/engineer.
Soil bearing capacity – 2,000 psf Minimum

Provide neat excavation for footing and place concrete immediately after excavation and inspection.

Pump water from footing excavation if greater than one inch.
Compact all fill to 95% ASTM D698 density.

Unit soil weight = 105 pcf
Internal angle of friction = 30 degrees

Coeff. Of friction between footing and soil = 0.5

Structural Aluminum:

Conform to latest edition of Florida Building Code and Aluminum Design Manual standard practice for aluminum design.

All aluminum shall be 6005-T5 (E= 10,000 ksi; Fy = 35 ksi) with a minimum wall thickness of 0.046"

Splicing prohibited without prior approval as to location and type.

Burning of holes in aluminum members is prohibited. Any member with burned holes must be replaced.

Aluminum Protection:

Shall be pursuant FBC 2003.8.4. Aluminum surfaces in contact with dissimilar materials, lime-mortar, concrete, or other masonry materials, shall be protected with powder coated or ESP paint or alkali-resistant coatings, such as heavy-bodied bituminous paint or water-white methacrylate lacquer.

Screws:

Aluminum self-tapping screws shall conform to ASME B18.6.4 specification.

Self-tapping screws shall meet the requirements of ADM J.5

Maximum fastener spacing shall not exceed (3+20t) where "t" is the member thickness in inches.

For roofing and siding connection, use minimum #12 screws for end and side laps spaced at 12" max for side lap and end lap fasteners shall be no more than 2" from the end of overlapping sheets.

For bottom plate and column base, secure with 1/4" tapcons a minimum embedment of 1 1/8" and 2 1/4" respectively into concrete footer.

Bolts:

Bolts and other fasteners shall be aluminum, stainless steel, hot-dip or electro-galvanized steel. Double cadmium plated steel bolts may also be used. Bolt holes diameter shall not exceed 1/16" larger than the bolt diameter and shall be spaced at a minimum of 2.5 times the bolt diameter with minimum edge distance of 1.5 times the bolt diameter.

Bolts shall meet the requirements of ADM J.3

Chair Rails, Purlins & Wind Brace:

Chair rails, purlins and wind brace shall conform with the below maximum span length. If the event contractor's specific site plan conflict with the below recommended length, the contractor shall utilize the more stringent dimensions and member sizes prior to ordering materials, fabrication and/or construction. Screen mesh cover areas shall be continuously secure to each top rail, bottom rail, chair rail, upright, beam and purlin.

Wind Speed = 130 MPH

2 x 2 Chair Rail = 7'-0" 2 x 2 Purlins = 7'-0" 2 x 2 Wind Brace = 4'-3" 2 x 3 (0.125) Wind Brace = 9'-0"
2 x 3 Chair Rail = 8'-0" 2 x 3 Purlins = 8'-0" 2 x 3 Wind Brace = 8'-0" 2 x 4 Wind Brace = 9'-0"

Concrete:

Conform to ACI 318, latest edition and ACI 301

Compressive Ultimate Strength (Minimum at 28 days) shall be 3000 psi

Exposed chamfer edges shall be 3/4"

Reinforcing Steel:

Conform to ACI 318 and 315, Latest edition

All reinforcement steel shall be ASTM A615 Grade 60.

Smooth dowels & ties shall be ASTM A185

Welded Wire Fabric shall be ASTM A185 or A82 (Flat sheet).

Deformed bar anchors shall be ASTM A496, Grade 70

Cover: Footing 3"

Washer:

Washers shall be used under bolt heads and under nuts.

Hole Alignment:

Poor matching holes must be rejected. Contractor shall prevent holes from drifting and distort the metal. All chips and foreign matter between contacting surfaces shall be removed before assembly.

Cables:

Contractor shall provide a minimum 1/8” diameter stainless steel cable tie down at side and rear walls of pool screen enclosure. Contractor shall secure cable to top of column located at each corner and where there is a difference in column height locations. In addition, cables shall be spaced to provide wall support not exceeding 227.5 ft² with bottom each end of cables secure to concrete slab with a minimum 3”ASTM A-36 steel clip with 2-1 1/2” x 1/4” tapcons or equal.

Beams & Uprights:

In the event of a conflict with the values in this table and the site specific plan, the contractor must utilize the more stringent dimensions and/or member sizes between the site specific plan and the below applicable span limitations prior to ordering materials, fabrication and/or construction.

130 MPH			
PRIMARY ROOF MEMBERS-POOL CAGE ENCLOSURES			
SIZE	Roof Span *Maximum Beam Spacing = 6'-0"	Roof Span *Maximum Beam Spacing = 6'-8"	Roof Span *Maximum Beam Spacing = 7'-2"
2 X 4	17'-9"	16'-9"	15'-6"
2 X 5	23'-3"	22'-0"	19'-0"
2 X 6	26'-0"	25'-0"	22'-9"
2 X 7	28'-0"	27'-0"	26'-6"
2 X 8	34'-0"	33'-0"	32'-6"
2 X 9	36'-0"	35'-0"	34'-6"
2 X 10	40'-0"	39'-0"	38'-6"

Upright -Pool Cage Enclosures				
Upright SIZE	130 MPH Height			
2 X 4	11'-6"			
2 X 5	13'-6"			
2 X 6	15'-0"			
2 X 7	16'-9"			
2 X 8	17'-9"			
2 X 9	18'-9"			
2 X 10	22'-0"			

Knee Bracing:

Contractor shall provide knee bracing on 45 degree angle pursuant the attach detail sheet that specified size and length requirements. Knee bracing on upright above super gutter intersection shall be connected to upright no more than 6” above the super gutter. Knee brace size shall be a minimum of 2 x 2 for beam span of 15’ max; 2 x 3 for 30’ max; 2 x4 for beam span greater than 30’.

Purlin:

Contractor is required to install purlins spaced to align with column spacing; however, spacing between purlins shall not exceed 7’-2”.

Header Beam:

Contractor is required to install a minimum 2 x 7 header beam supported with 3 x 3 column space at 10 feet (max) with a 2’ x 2’ x 1’-6” concrete footer with 3#5 each way when screen enclosed is required to be attached super gutter at the interface of the insulated roof panel. Contractor is required to install insulated roof covering pursuant to the Florida product approval specification (35 psf).

Intermediate Girts:

Contractor is required to install intermediate chair rails/girts spaced at mid-span between the chair rails and top rail or 6'-0" max on center when column height exceeds 11 feet. Contractor is also required to install one additional intermediate chair rail/girt to be located 3 feet below the top rail when column height exceeds 14 feet.

Edge Distance:

Contractor is required to install uprights to provide a 2” minimum clearance from edge of slab and/or footer.

In the event of a conflict in member sizes shown on the plans and the general notes, the contractor must utilize the more stringent member size requirements.
 Engineer: Michael Thompson, P.E. 47509/CA30930

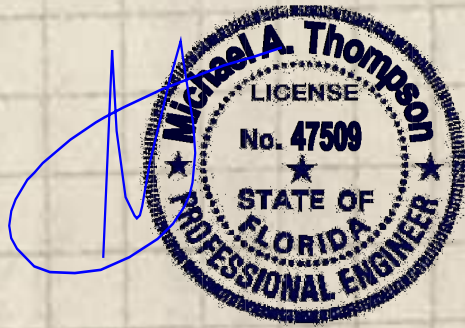

Digitally signed by MICHAEL THOMPSON
 Reason: This item has been signed & sealed by Michael A. Thompson on the date adjacent to the seal. Printed copies of this document are not considered signed and sealed and the signature must be verified on any electronic copies.
 Date: 2024.12.31 09:22:30 -05'00'

HOUSE

HOUSE

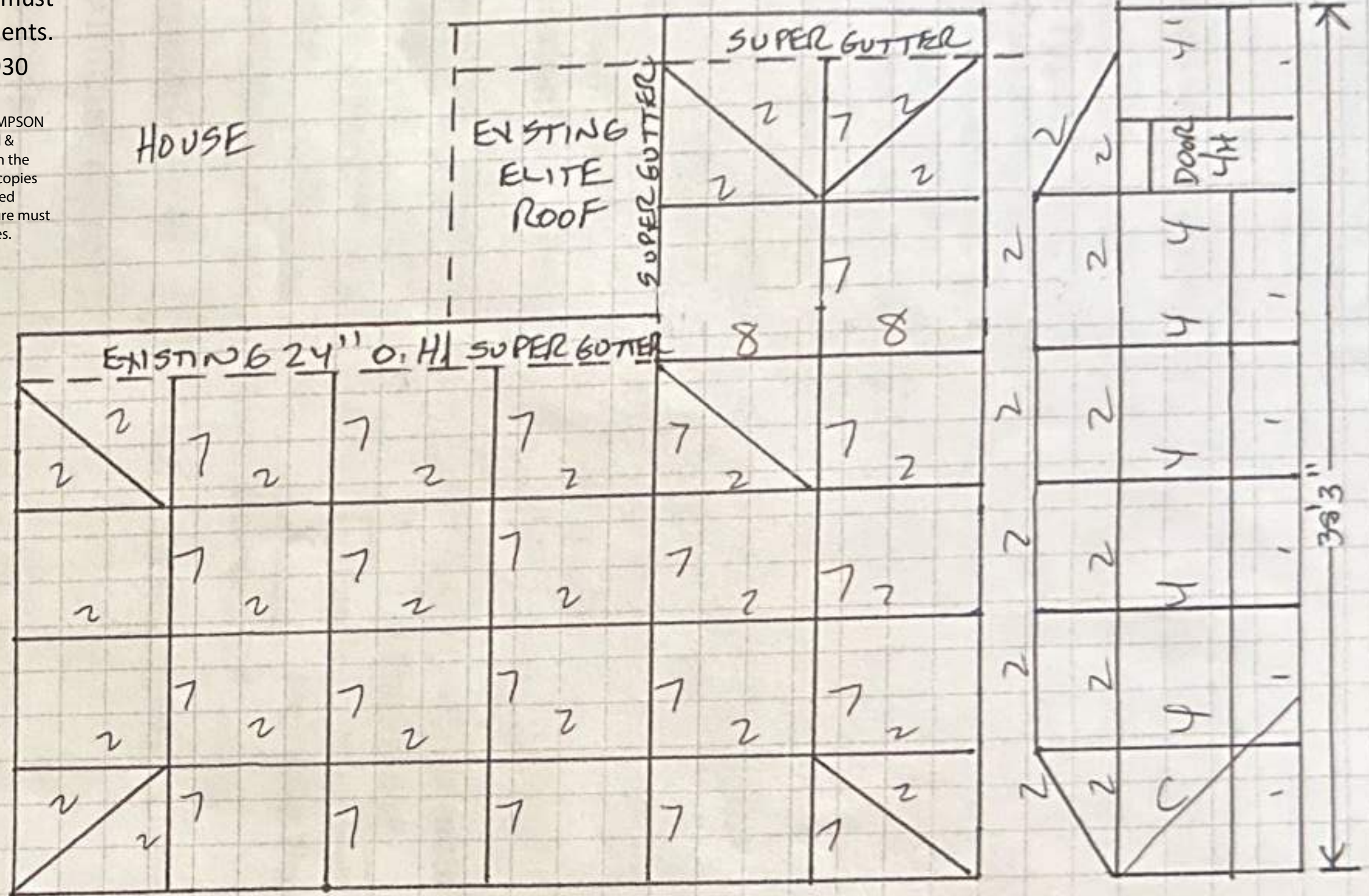
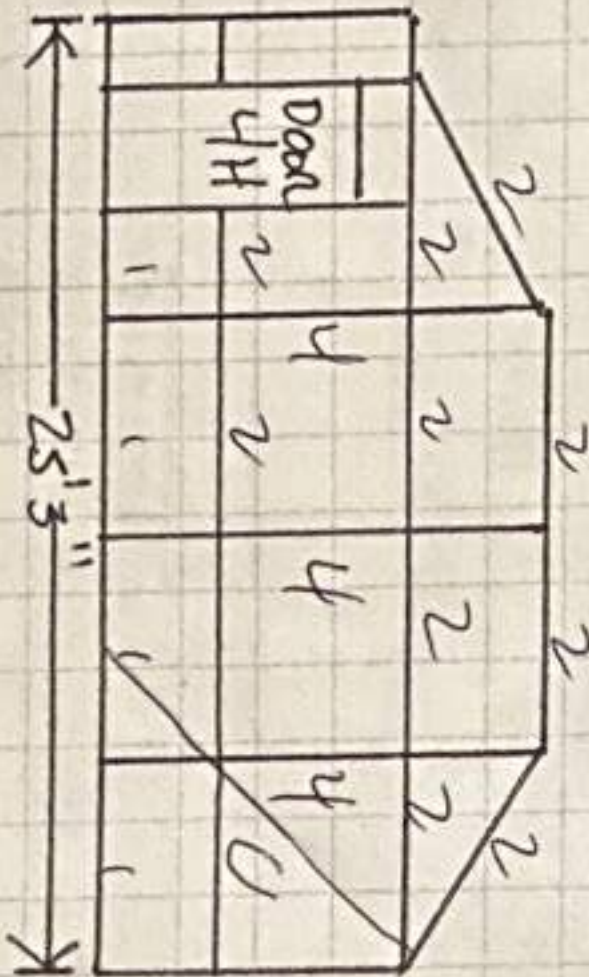

EMILY BURNETTE
 314 SW ARROWBEND DR,
 LAKE CITY, FL,
 RESTORATION SPECIALISTS
 Ocala, FL,

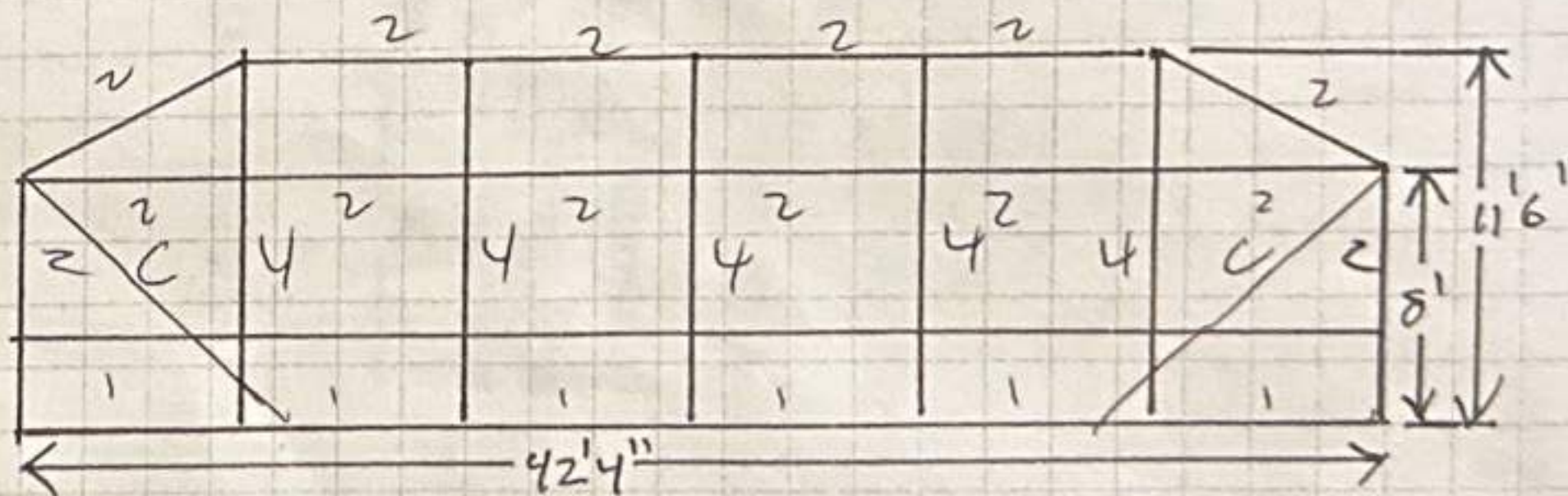

8 = 2x8 Smb
 7 = 2x7 Smb
 4 = 2x4 Smb
 2 = 2x2x.044
 1 = 1x2x.044
 Pool enclosure
 C=cables

ALUMINUM SCREEN DESIGN

SEE GENERAL NOTES & DESIGN STANDARD FOR ADDITIONAL INFORMATION (TYP.)

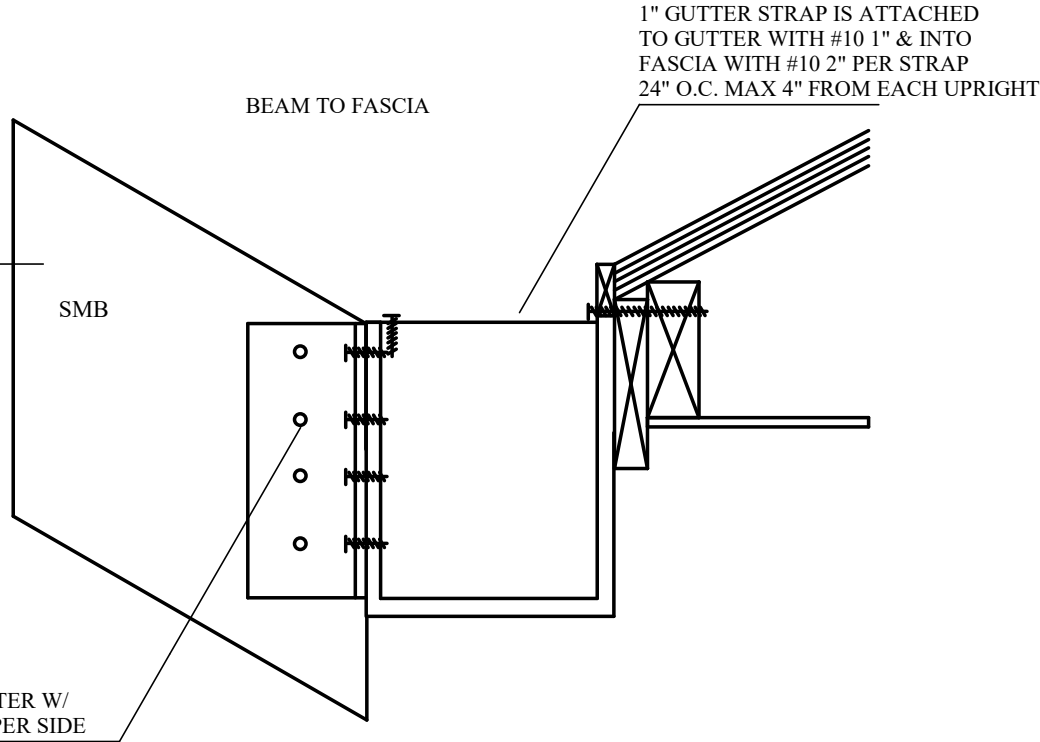

BEAM IS ATTACHED TO GUTTER W/ 2X2X1/8" ANGLE & (4) #10 1" PER SIDE

BEAM TO WALL

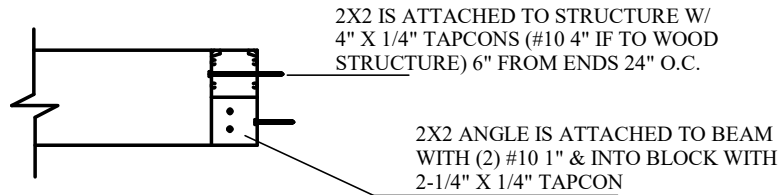

ALUMINUMSCREENDSIGN.COM
 ALUMINUMSCREENDSIGN
 @YAHOO.COM
 PHONE: 407-734-1470
 FAX: 407-734-1790

PURLINS ATTACHED TO BEAM W/ (3) #10 2" SMS, PLACE WASHER UNDER SCREW IN GUSSET CORNER

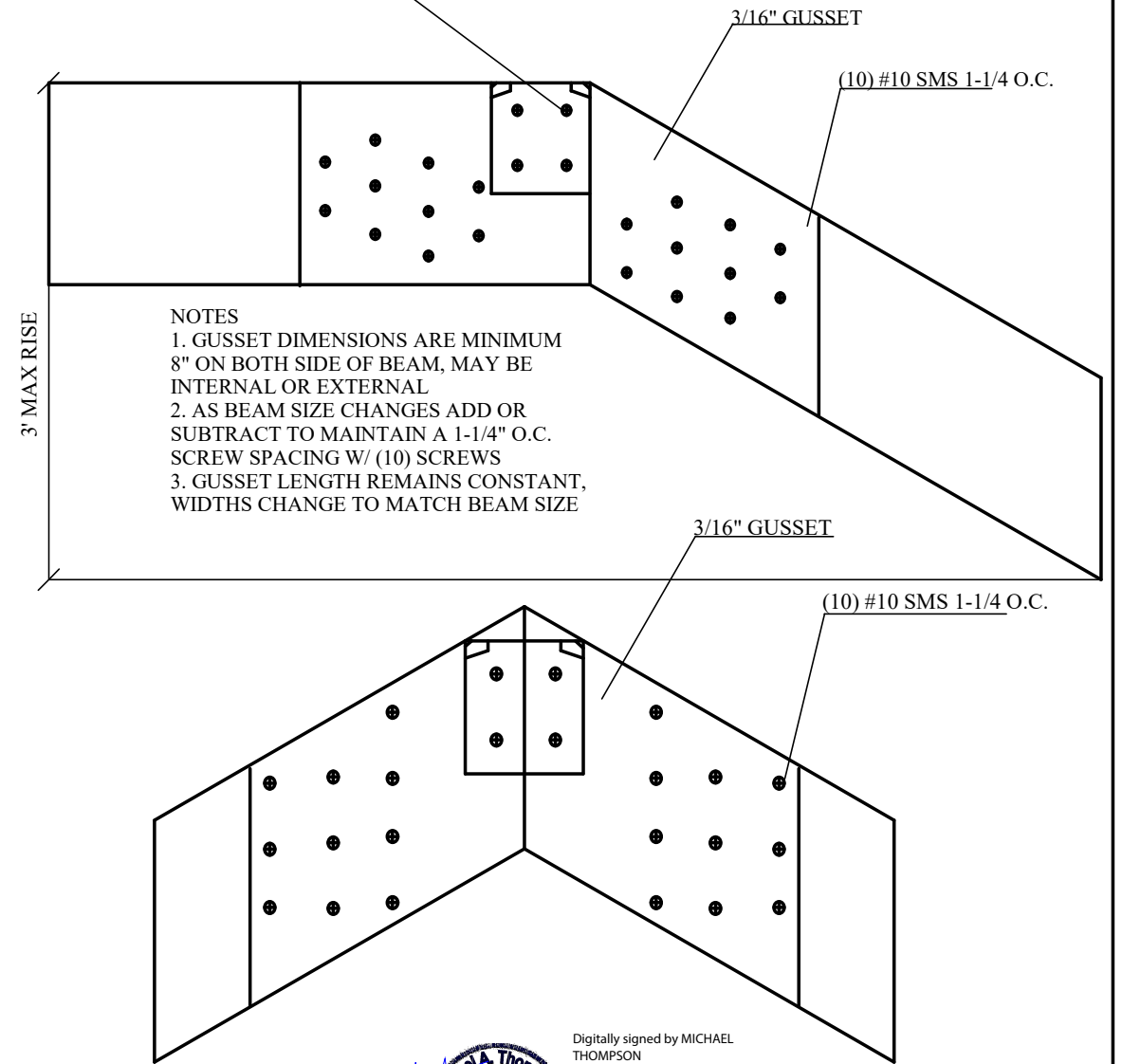

DESIGN STATEMENT

METAL IS .046 THICKNESS OR GREATER, ALLOY IS 6005-T5
 ALL TAPCONS SHALL PROVIDE MINIMUM OF 1 1/8" CONCRETE EMBEDMENT DEPTH

THIS STRUCTURE HAS BEEN DESIGNED IN ACCORDANCE TO MEET THE REQUIREMENTS OF THE 2023 (8TH EDITION) FLORIDA BUILDING CODE FOR OPEN AND SEMI-OPEN STRUCTURES AND SHALL WITH STAND ULTIMATE WIND SPEEDS OF 130 MPH (FOR 3 SECOND GUSTS) NOMINAL SPEED 101.4 MPH UP TO A 15FT ROOF HEIGHT, FACTOR OF 1.0, AND EXPOSURE B, RISK CATEGORY 1. CONTRACTOR SHALL FIELD VERIFY ALL PLANS DIMENSIONS PRIOR TO MATERIAL PURCHASE, FABRICATION AND CONSTRUCTION CONTRACTOR SHALL NOTIFY THE ENGINEER IMMEDIATELY SHOULD SITE CONDITIONS DIFFER FROM CONSTRUCTION PLANS

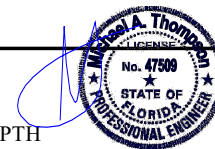

Digitally signed by MICHAEL THOMPSON
 Reason: This item has been signed & sealed by Michael A. Thompson on the date adjacent to the seal. Printed copies of this document are not considered signed and sealed and the signature must be verified on any electronic copies.
 Date: 2024.12.31 09:23:03 -05'00'

MICHAEL THOMPSON
 4401 VINELAND ROAD
 SUITE A6
 ORLANDO, FL 32811
 P.E. # 47509
 CA#30930

ALUMINUM SCREEN DESIGN

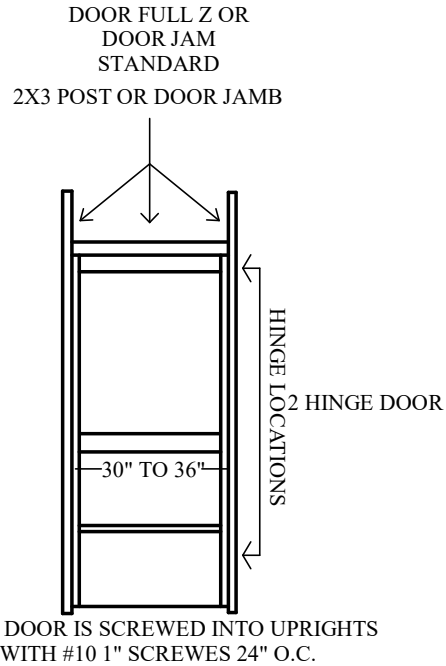

SIDE WALL CONNECTION DETAILS WHEN PURLIN DOESNT HIT POST

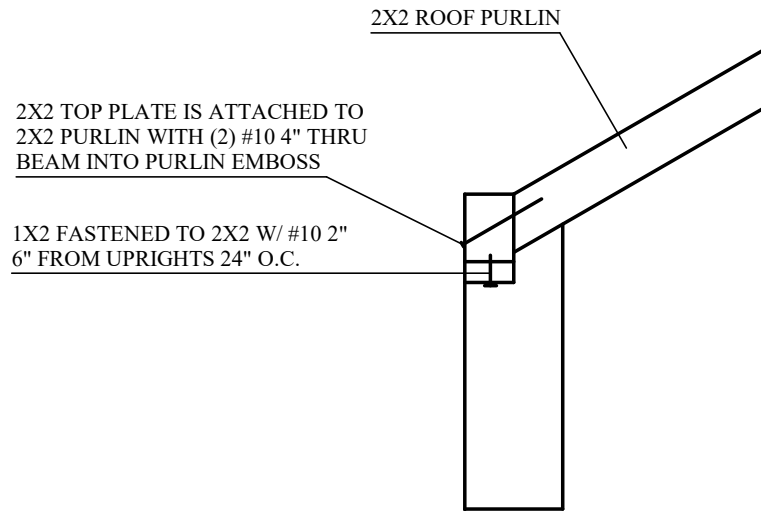

SIDE WALL CONNECTION DETAILS WHEN PURLIN DOESNT HIT POST

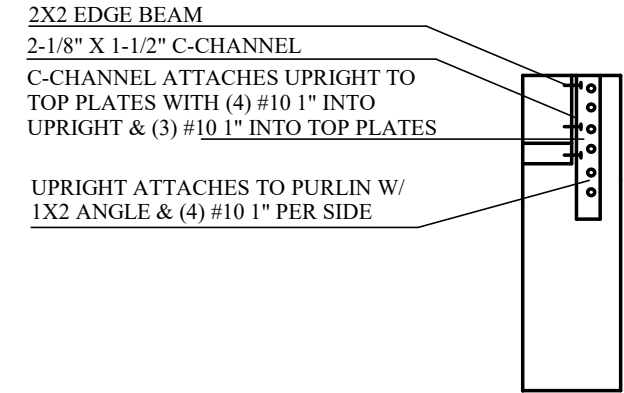

SLOPED PURLIN CONNECTION DETAIL

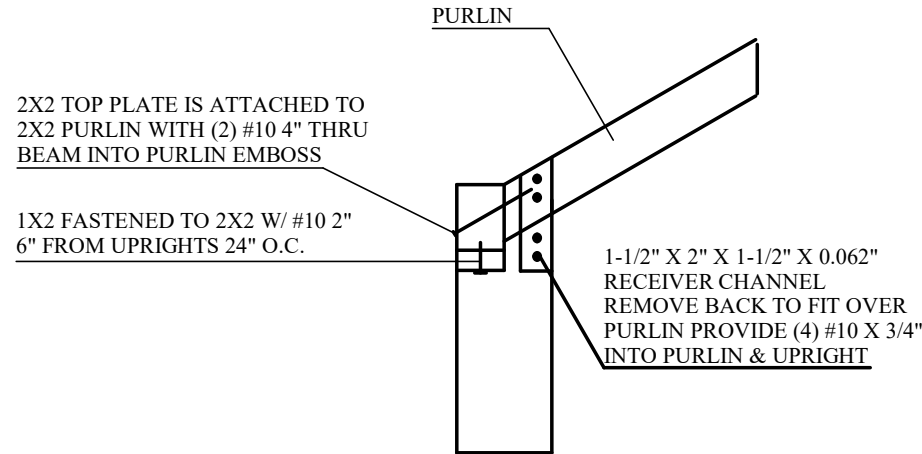

FRONT WALL TO BEAM

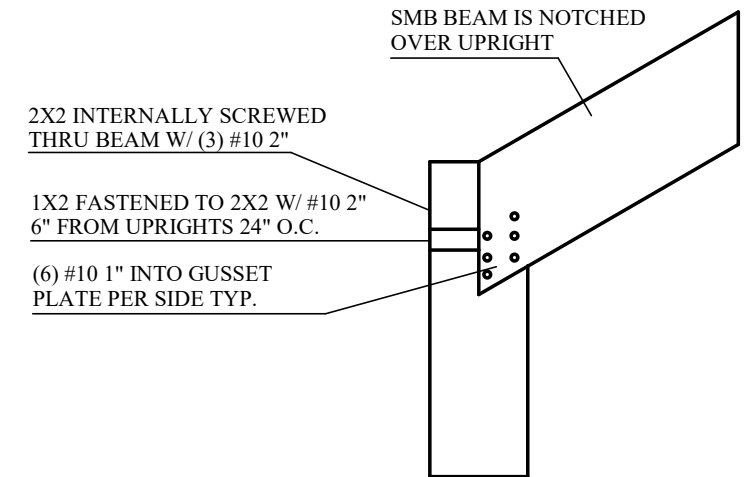

ALUMINUMSCREENDESIGN.COM
ALUMINUMSCREENDESIGN
@YAHOO.COM
PHONE: 407-734-1470
FAX: 407-734-1790

DESIGN STATEMENT

METAL IS .046 THICKNESS OR GREATER, ALLOY IS 6005-T5
ALL TAPCONS SHALL PROVIDE MINIMUM OF 1 1/8" CONCRETE EMBEDMENT DEPTH

THIS STRUCTURE HAS BEEN DESIGNED IN ACCORDANCE TO MEET THE REQUIREMENTS OF THE 2023 (8TH EDITION) FLORIDA BUILDING CODE FOR OPEN AND SEMI-OPEN STRUCTURES AND SHALL WITH STAND ULTIMATE WIND SPEEDS OF 130 MPH (FOR 3 SECOND GUSTS) NOMINAL SPEED 101.4 MPH UP TO A 15FT ROOF HEIGHT, FACTOR OF 1.0, AND EXPOSURE B, RISK CATEGORY 1. CONTRACTOR SHALL FIELD VERIFY ALL PLANS DIMENSIONS PRIOR TO MATERIAL PURCHASE, FABRICATION AND CONSTRUCTION CONTRACTOR SHALL NOTIFY THE ENGINEER IMMEDIATELY SHOULD SITE CONDITIONS DIFFER FROM CONSTRUCTION PLANS

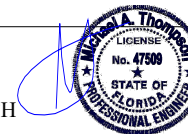

Digitally signed by MICHAEL THOMPSON
Reason: This item has been signed & sealed by Michael A. Thompson on the date adjacent to the seal. Printed copies of this document are not considered signed and sealed and the signature must be verified on any electronic copies.
Date: 2024.12.31 09:23:13 -05'00'

MICHAEL THOMPSON
1401 VINELAND ROAD
SUITE A6
ORLANDO, FL 32811
P.E. # 47509
CA#30930

ALUMINUM SCREEN DESIGN

CABLE DETAIL

K BRACING DETAIL

CABLE DETAIL

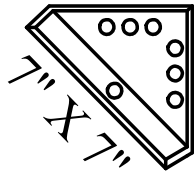

1/8" THICK ANGLE BRACKET ATTACHED TO UPRITE AND GIRT WITH (6) #10 1"

5/16" EYE BOLT WELDED CLOSED WITH DOUBLE NUTS COMPRESSION SLEEVE

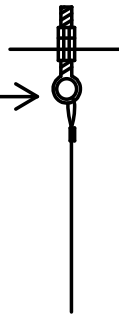

SIDE VIEW
COMPRESSION SLEEVE
3" A.S.T.M. A-36 STEEL CLIP WITH (2) 2-1/4" X 1/4" TAPCONS

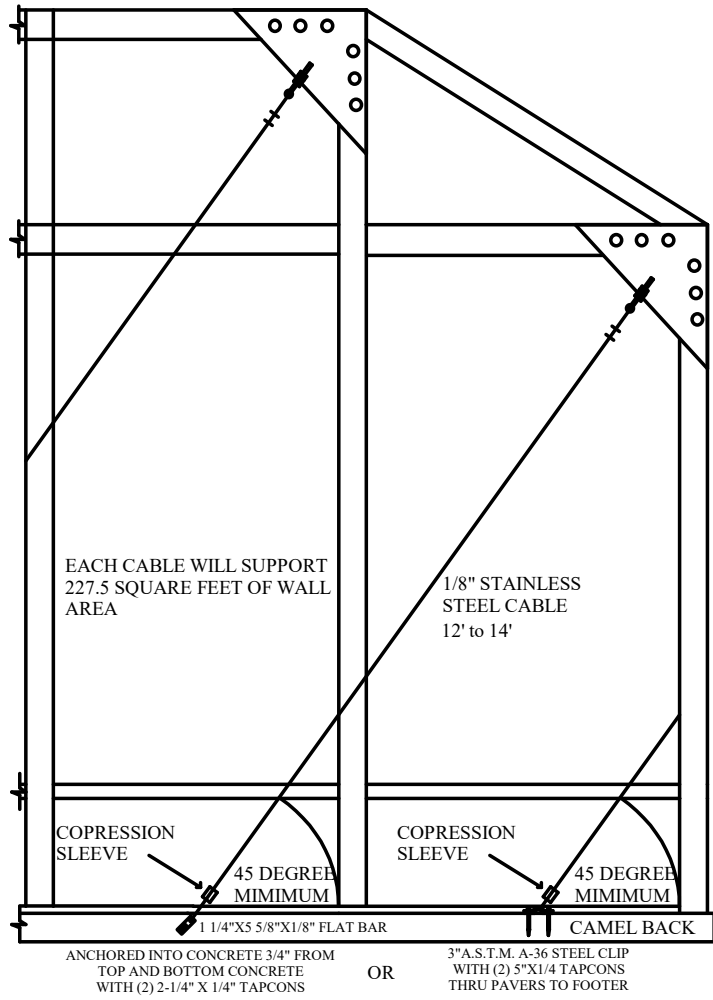
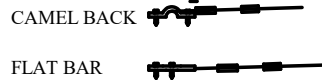

OR

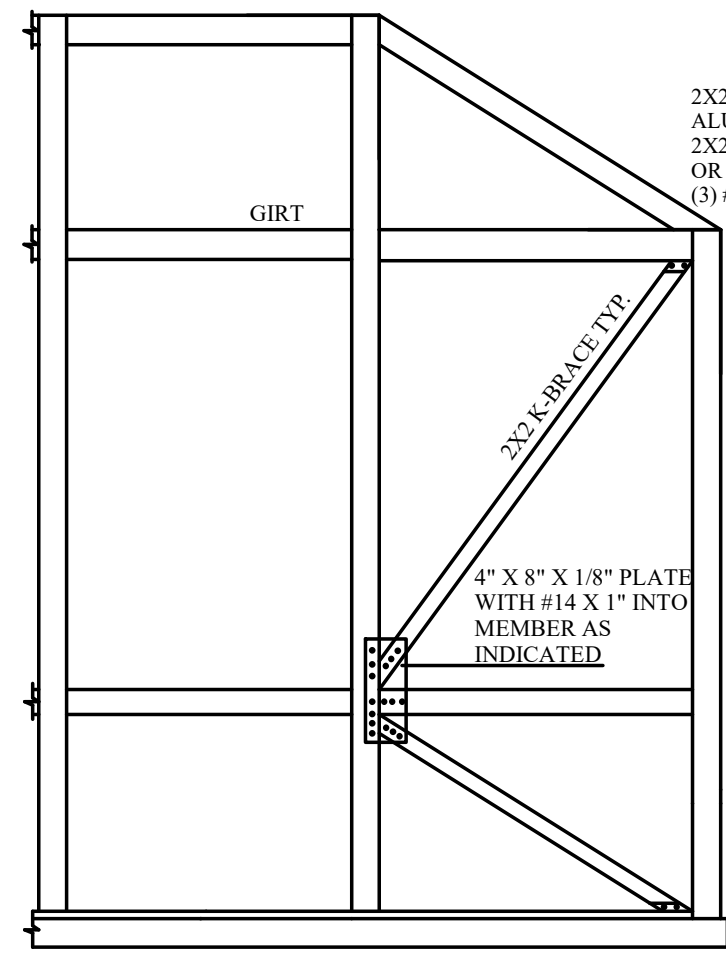

2X2 K BRACE IS ATTACHED TO ALUMINUM STRUCTURE WITH 2X2" C CHANNEL & (6) #10 1" OR BLIND SCREWED WITH (3) #10 2" PER END

IT SHALL BE THE RESPONSIBILITY OF THE CONTRACTOR TO INFORM THE HOMEOWNER THAT THE CABLES AND CABLE ATTACHMENT MUST BE INSPECTED BY THE HOMEOWNER AT LEAST TWICE A YEAR TO ELIMINATE ANY DEFICIENCIES ASSOCIATED WITH TENSION SLACK AND/OR CORROSION AND IF NECESSARY TO MAKE CORRECTIVE REPAIRS TO MAINTAIN THE CABLE FULL TENSION (NO SLACK) DESIGNED FOR STRUCTURAL LATERAL STABILITY

Digitally signed by MICHAEL THOMPSON
Reason: This item has been signed & sealed by Michael A. Thompson on the date adjacent to the seal. Printed copies of this document are not considered signed and sealed and the signature must be verified on any electronic copies.
Date: 2024.12.31 09:23:26 -05'00'



ALUMINUMSCREENDSIGN.COM
ALUMINUMSCREENDSIGN@YAHOO.COM
PHONE: 407-734-1470
FAX: 407-734-1790

DESIGN STATEMENT

METAL IS .046 THICKNESS OR GREATER, ALLOY IS 6005-T5
ALL TAPCONS SHALL PROVIDE MINIMUM OF 1 1/8" CONCRETE EMBEDMENT DEPTH

THIS STRUCTURE HAS BEEN DESIGNED IN ACCORDANCE TO MEET THE REQUIREMENTS OF THE 2023 (8TH EDITION) FLORIDA BUILDING CODE FOR OPEN AND SEMI-OPEN STRUCTURES AND SHALL WITH STAND ULTIMATE WIND SPEEDS OF 130 MPH (FOR 3 SECOND GUSTS) NOMINAL SPEED 101.4 MPH UP TO A 15FT ROOF HEIGHT, FACTOR OF 1.0, AND EXPOSURE B, RISK CATEGORY 1. CONTRACTOR SHALL FIELD VERIFY ALL PLANS DIMENSIONS PRIOR TO MATERIAL PURCHASE, FABRICATION AND CONSTRUCTION CONTRACTOR SHALL NOTIFY THE ENGINEER IMMEDIATELY SHOULD SITE CONDITIONS DIFFER FROM CONSTRUCTION PLANS

MICHAEL THOMPSON
4401 VINELAND ROAD
SUITE A6
ORLANDO, FL 32811
P.E. # 47509
CA#30930

ALUMINUM SCREEN DESIGN

SIDE WALL DETAIL

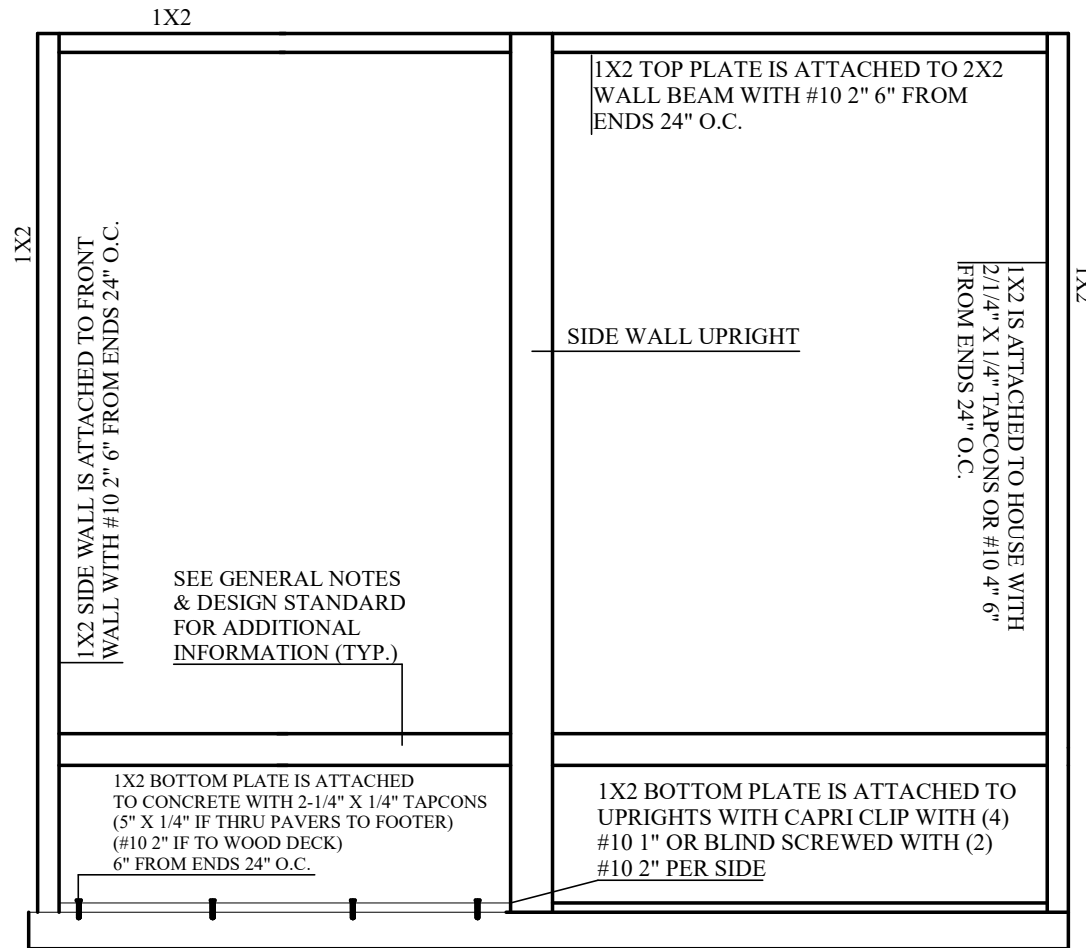

CHAIR RAIL & KICK PLATE DETAIL

CHAIR RAILS & GIRTS ARE ATTACHED W/ INTERNAL CLIPS W/ (4) #10 1", CAPRI CLIPPED, W/ RECIEVING CHANNEL & (6) #10 1" W/ (8) #10 1", OR BLIND SCREWED W/ (3) #10 2"

KICK PLATE IS ATTACHED TO STRUCTURE WITH #10 1" 6" FROM ENDS 18" O.C. (OPTIONAL)

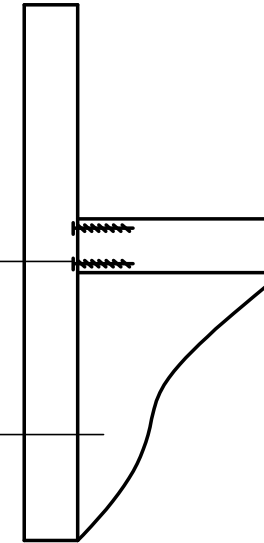

BLIND CLIP & CAPRI CLIP DETAILS

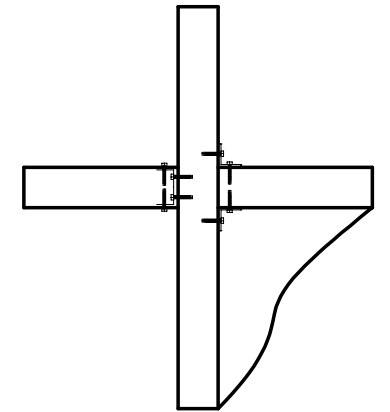

RECIEVING CHANNEL CLIP DETAILS

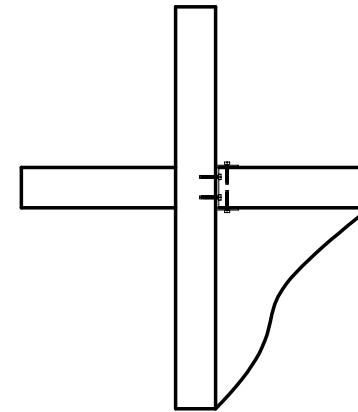

SELF MATING UPRIGHT DETAILS

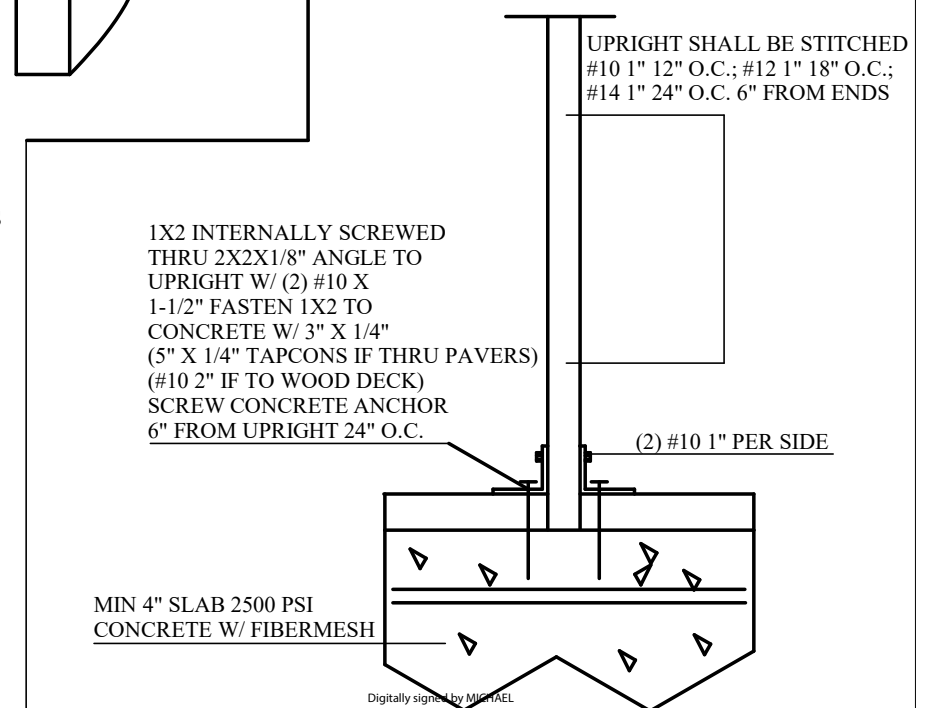

ALUMINUMSCREENDESIGN.COM
ALUMINUMSCREENDESIGN
@YAHOO.COM
PHONE: 407-734-1470
FAX: 407-734-1790

DESIGN STATEMENT

METAL IS .046 THICKNESS OR GREATER, ALLOY IS 6005-T5
ALL TAPCONS SHALL PROVIDE MINIMUM OF 1 1/8" CONCRETE EMBEDMENT DEPTH

THIS STRUCTURE HAS BEEN DESIGNED IN ACCORDANCE TO MEET THE REQUIREMENTS OF THE 2023 (8TH EDITION) FLORIDA BUILDING CODE FOR OPEN AND SEMI-OPEN STRUCTURES AND SHALL WITH STAND ULTIMATE WIND SPEEDS OF 130 MPH (FOR 3 SECOND GUSTS) NOMINAL SPEED 101.4 MPH UP TO A 15FT ROOF HEIGHT, FACTOR OF 1.0, AND EXPOSURE B, RISK CATEGORY 1. CONTRACTOR SHALL FIELD VERIFY ALL PLANS DIMENSIONS PRIOR TO MATERIAL PURCHASE, FABRICATION AND CONSTRUCTION CONTRACTOR SHALL NOTIFY THE ENGINEER IMMEDIATELY SHOULD SITE CONDITIONS DIFFER FROM CONSTRUCTION PLANS



Digitally signed by MICHAEL THOMPSON

Reason: This item has been signed & sealed by Michael A. Thompson on the date adjacent to the seal. Printed copies of this document are not considered signed and sealed and the signature must be verified on any electronic copies.
Date: 2024.12.31 09:23:37 -05'00'

MICHAEL THOMPSON
4401 VINELAND ROAD
SUITE A6
ORLANDO, FL 32811
P.E. # 47509
CA#30930