



Town of Fort White  
P.O. Box 129 Fort White, FL 32038  
386-497-2321 Fax: 386-4974946

APPLICATION FOR BUILDING PERMIT/COMPLIANCE

\$50.00 FEE paid 12-19-24 cr # 1004

FILE No. \_\_\_\_\_ RECPT No. \_\_\_\_\_

Applicant's Name: Beryl Sanders Phone: \_\_\_\_\_

Address: 321 SW Greenwood Dr

Owner's Name: Beryl SAME Phone: 916-633-9956

Address: SAME

Contractor's Name: OWNER builder

Address: \_\_\_\_\_

\*\*\*\*Location of property: Lot 8 Thornwood S/D

\*\*\*\*Type of development: 44 x 52 metal storage building with electric.

Land use & zoning: Ag / Ag.

Minimum set-back: Street-front/side 30' rear 25' side 25' max height 35'

Legal Description (acres): \_\_\_\_\_  
04056-108

I certify that all work will be performed to meet the standards of all laws regulating construction in this jurisdiction and that all the foregoing information is accurate and all work will be done in compliance with all laws regulating construction and zoning.

Beryl Sanders Contractor's  
License Number Applicant/Owner/Contractor

Connie Brecken 12-19-24 Date Approved  
by Reviewing Clerk

\*\*\*\*\*IF PROPERTY IS NOT OWNED BY APPLICANT, A STATEMENT FROM THE OWNER AUTHORIZING USE OF PROPERTY FOR THE TYPE OF DEVELOPMENT STATED ON THIS APPLICATION WILL BE REQUIRED.

File No. \_\_\_\_\_

Town of Fort White  
Building Compliance Check List

Name of Applicant Beryl Sanders

Address 321 SW Greenwood Terr. F.W. 32038

Phone 916-633-9956

Physical location of site and current zoning A9/A9

Type of Construction  New ( ) remodel/renovation/fire damage

Describe Construction metal storage building with electric - 44x52

- Authorized owner or builder signs compliance application.
- Zoning is appropriate for type of construction.
- ( ) Property will ( ) will not require application to SRWMD for water use/runoff permit.
- ( ) Property will require curb cut or access/culvert over road right of way from:  
 DOT  Columbia County  Town of Fort White

- ( ) Property will  will not require Health Dept. Sanitary WasteWater Permit.
- ( ) Property will  will not require potable fresh water supply from:  
 private well  Town of Fort White municipal water works.

- Property will require slab to be at least 1 foot above elevation (crown) of roadway.
- ( ) Property will  will not require approval of solid waste removal facilities.
- ( ) Property will  will not require permit for infill or land removal.

Applicant understands that a copy of the Town of Fort White Land Use Certification must be taken to Columbia County Building Department for application and issuance of building permit. Certification of land use or zoning by the Town of Fort White is NOT a building permit.

Other steps required for Building Compliance: Property Owner will be responsible for submitting a copy of the Columbia County Building Permit to the Town of Fort White.

The applicant and Town of Fort White Clerk's Office have reviewed the foregoing information and the information is true and correct.

Beryl Sanders  
Signature of Applicant

Ann Breechen  
Signature of Reviewing Clerk

12-19-24  
Date

Compliance given to applicant on  
Date 12-19-24

Benny + Carol Sanders  
321 NW Greenwood Ter  
Ft White, FL 32038

Proposed Metal Building and Driveway

366.25 ADU

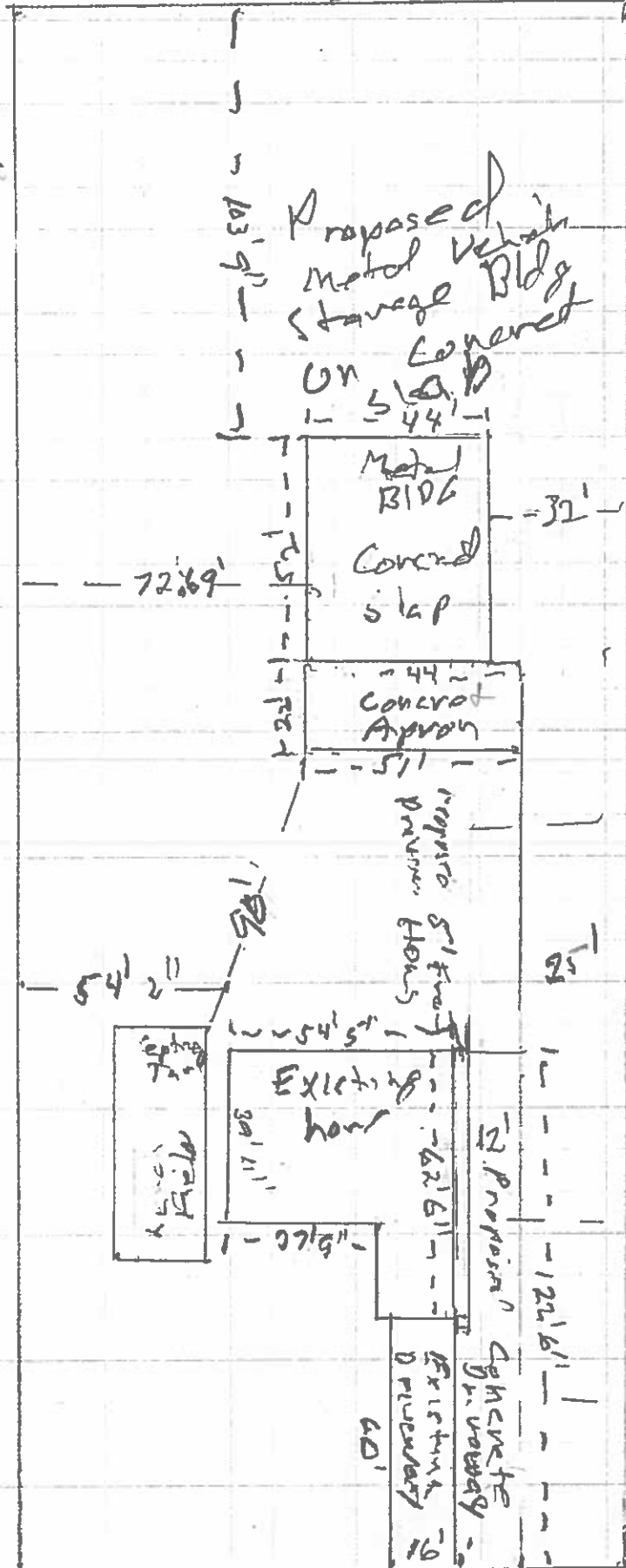

Driveway from house to concrete apron NOT concrete

12' x 62'  
Proposed concrete driveway by house

Front Proposed Driveway 20' x 60'





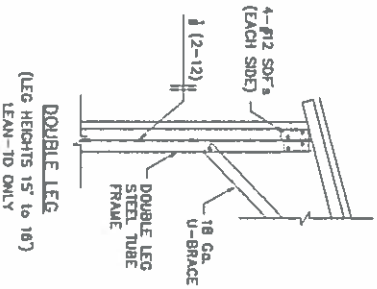
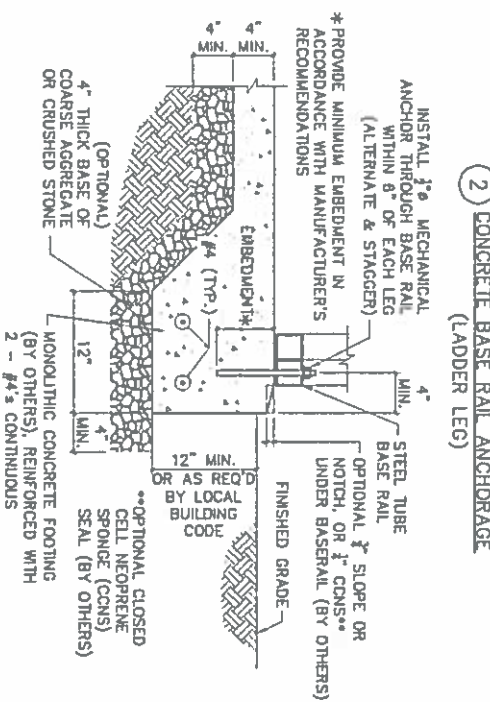
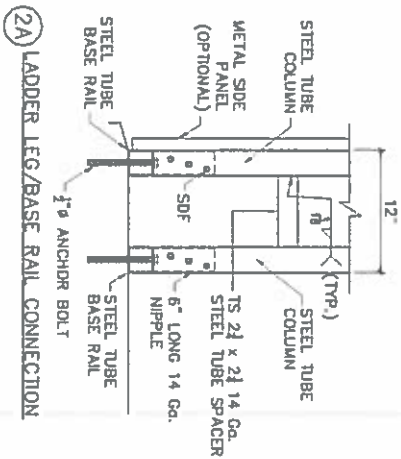
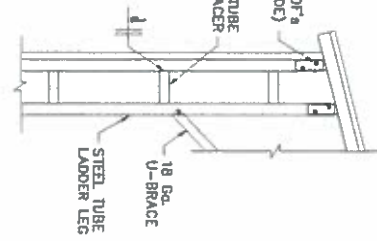
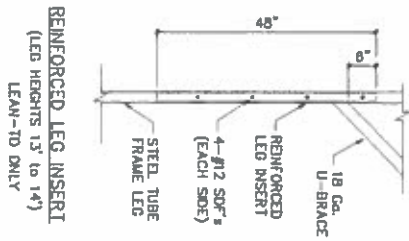
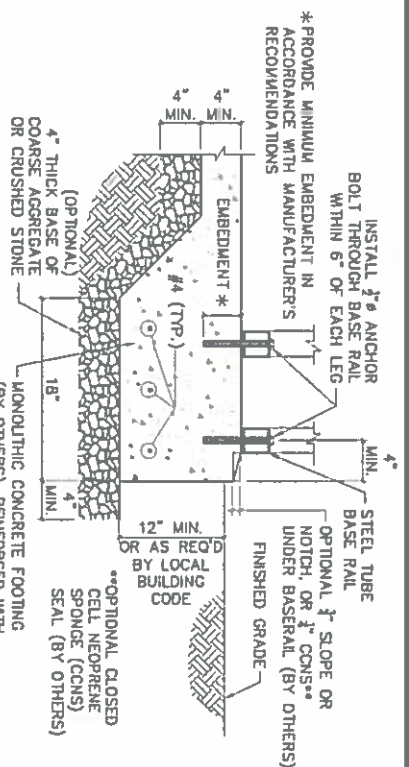
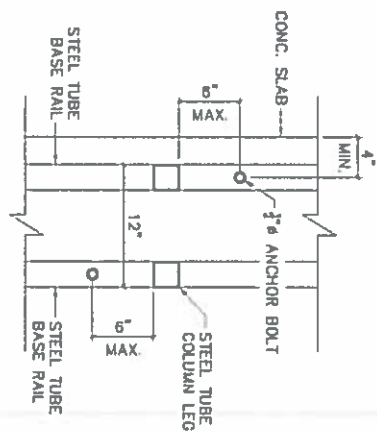
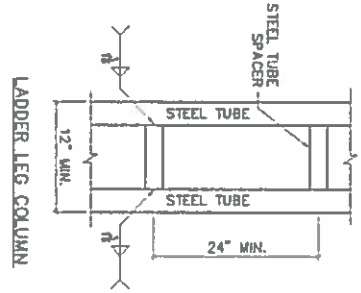
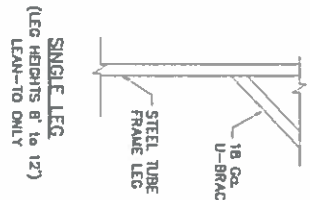

**CRAWL SPACE DOOR SYSTEMS, INC.**  
 5741 Boysside Road, #105  
 Virginia Beach, VA 23455  
 Engineered Flood Vent  
 Model CSBA816

OR Approved Equal  
**FLOOD VENTS**

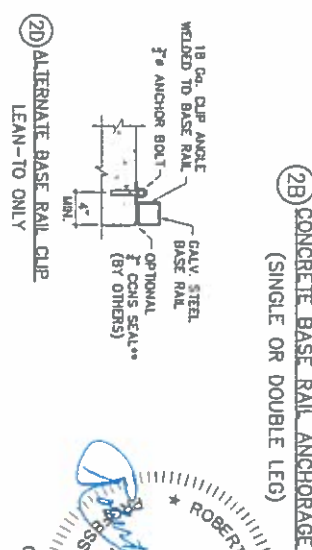
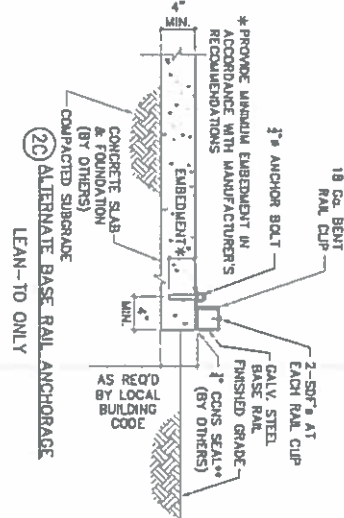

**ROBERT L. LUEBBERS**  
 LICENSE No. 01216  
 PROFESSIONAL ENGINEER  
 STATE OF FLORIDA  
 01/04/2024  
 SHEET 3 OF 4

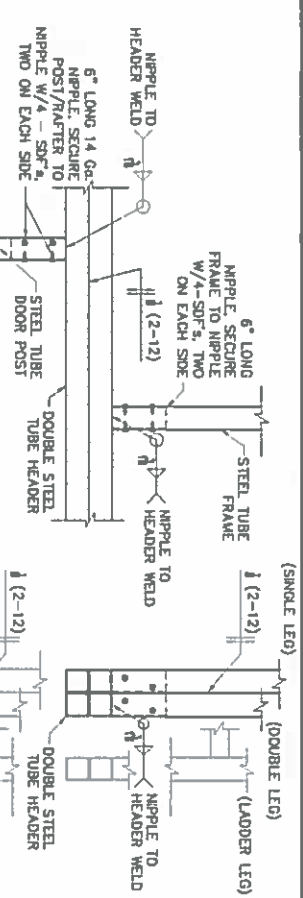

**1** SIDE HEADER DETAIL  
(DOUBLE HEADER FOR 8 TO 12' OPENING,  
ONE HEADER FOR SINGLE LEG,  
AND LADDER LEG)

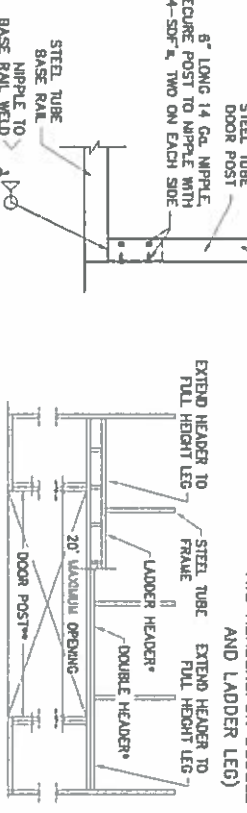

**2** LEAN-TO SIDE BASE RAIL  
CONNECTION DETAIL

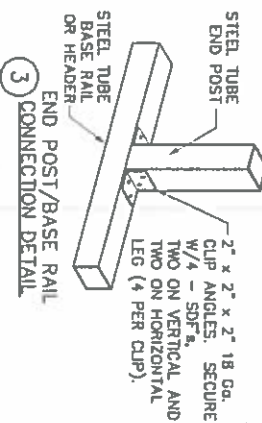

**3** END POST/BASE RAIL  
CONNECTION DETAIL

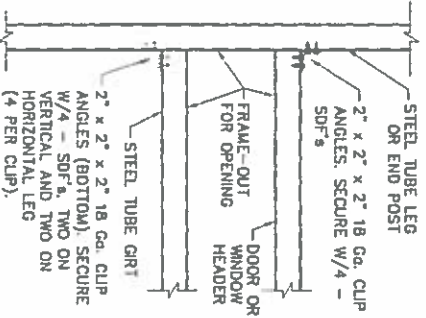

**4** END WALL TO HEADER AND  
GIRT TO POST CONNECTION

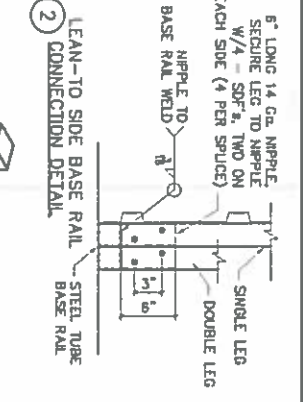

**5** POST/BASE RAIL DETAIL

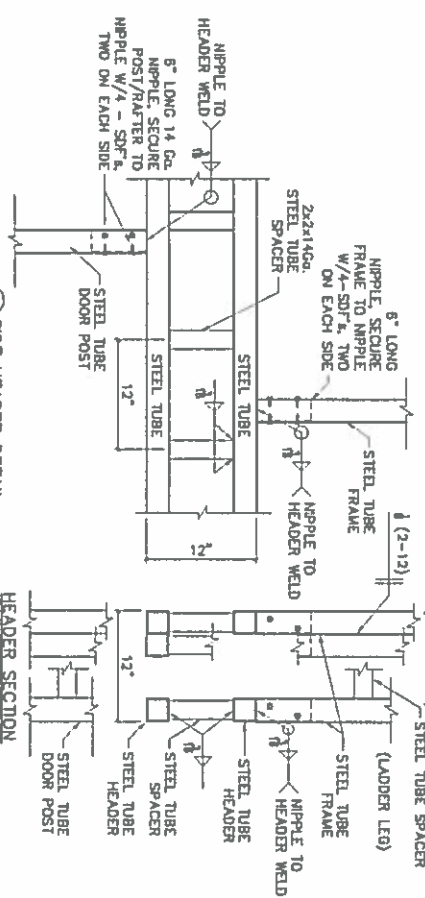

**6** SIDE HEADER DETAIL  
(LADDER STYLE FOR  
13' TO 20' OPENING)

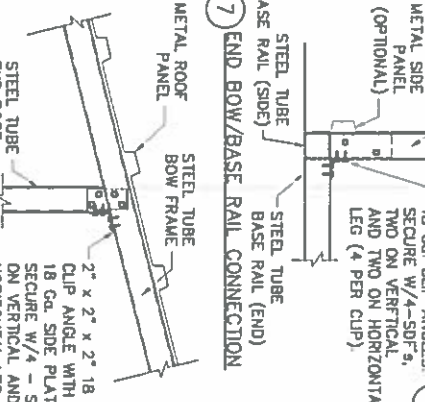

**7** END BOW/BASE RAIL CONNECTION

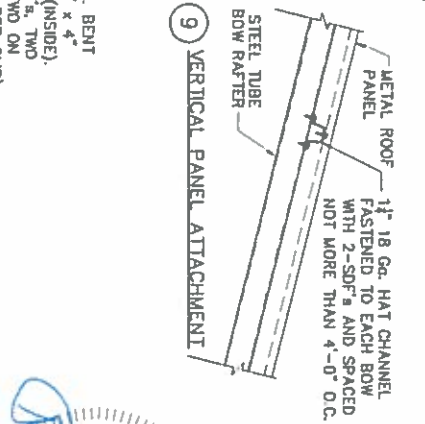

**8** END POST TO BOW FRAME CONNECTION

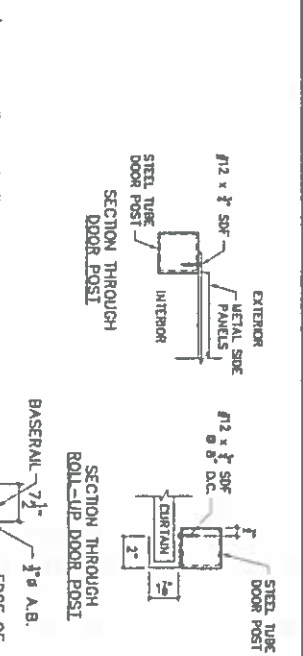

**9** SECTION THROUGH  
ROLL-UP DOOR POST

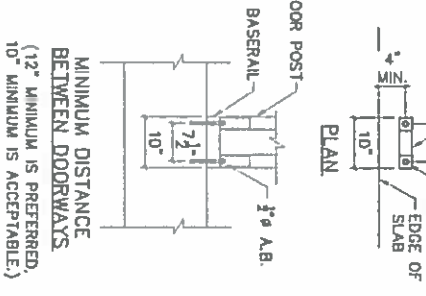

MINIMUM DISTANCE  
BETWEEN DOORWAYS  
(12\"/>

