

**PARAGON POOLS**

Do not duplicate - This drawing is the property of Paragon Pools and may be purchased separately. No duplication allowed

<b>Adams Construction -Duarte Job</b> 673 SW Bellflower Dr Lake City, FL 32024	
<b>Paragon Pools</b> (386) 755-7300	
License CPC1456799	DESIGNER: Brent Handy Brent@ParagonPoolsOnline.com
SCALE 1/8" = 1'	REV SHEET 1 OF 1

Approx 1,150' to Rear prop line

Approx 325' to Side prop line

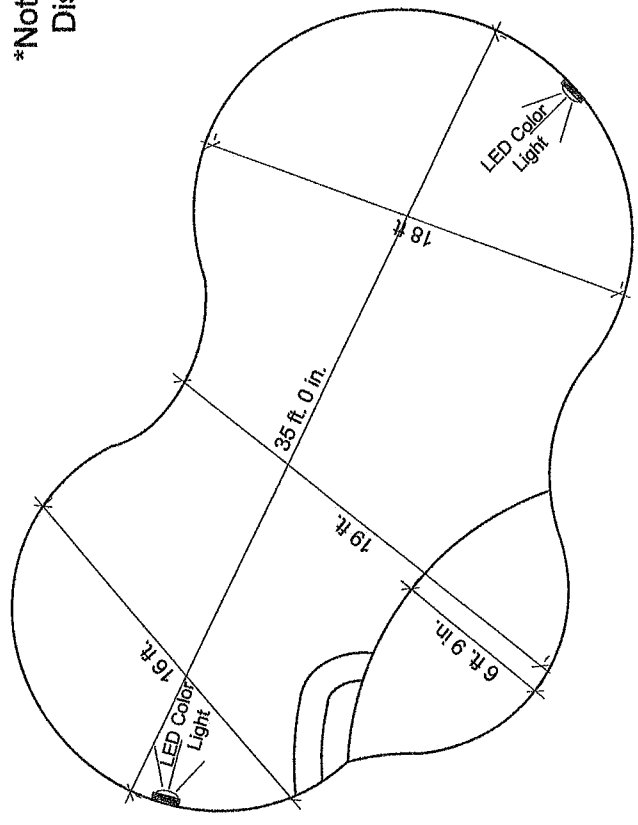

Approx 750' to Side prop line

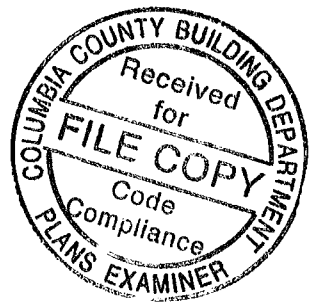

Approx 1,365' to Front prop line

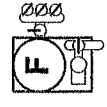
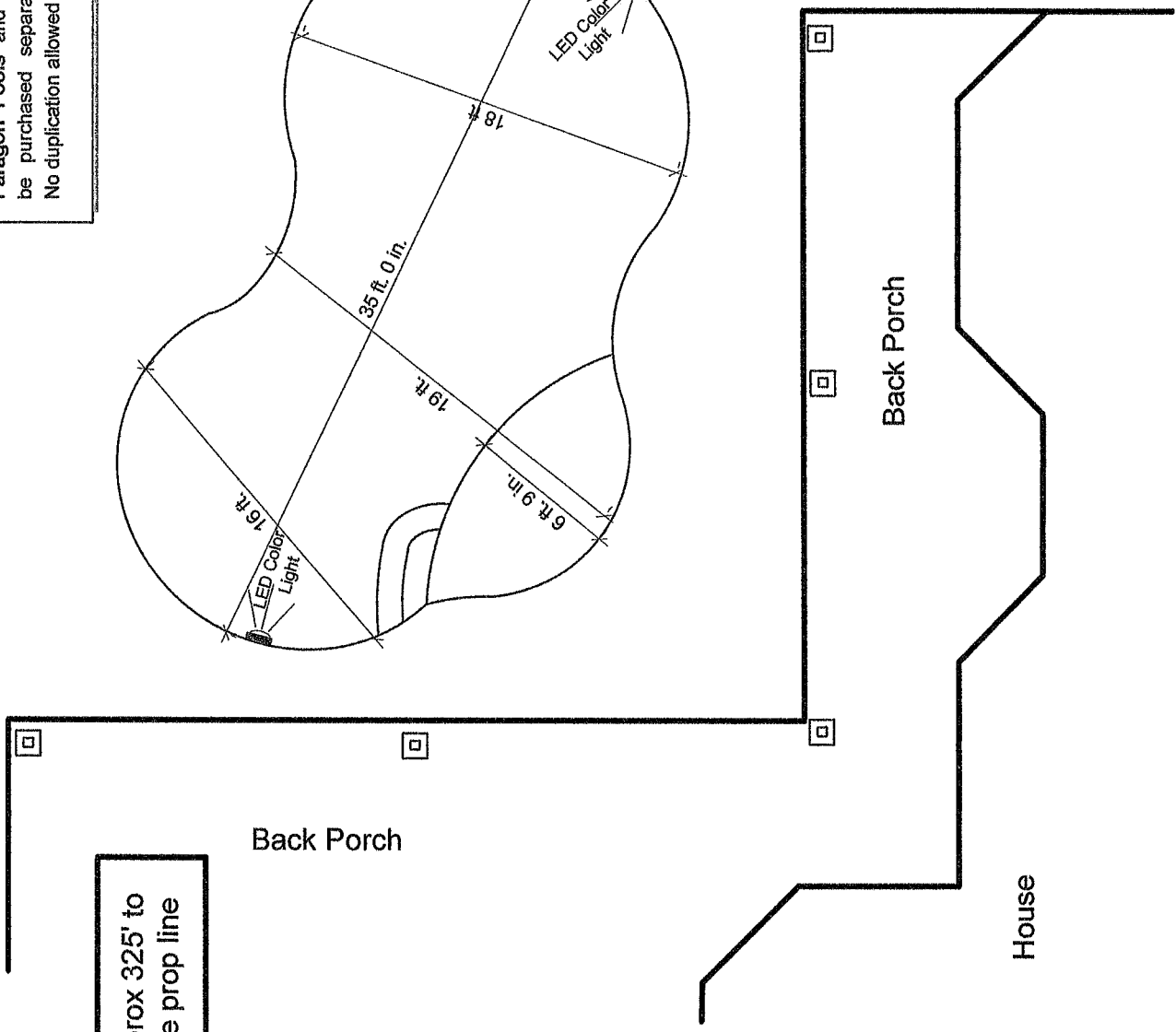

\*Note: House and pool are located on 80 acres. Distance to property lines are approximate.

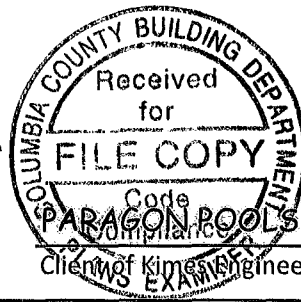

**Worksheet showing data for compliance with 2010 FBC, ANSI/APSP- 15**

Owner: DIOGENES & THERESA DUARTE Address: 673 SW BELL FLOWER DR Lot: M&B

**ANSI 15 Filtration Flow** Area: LAKE CITY

Volume of Pool Area 573 x Avg Depth 4 = Vol in CF 2292

Vol in CF x 7.48 gal/CF = 17144 GALLONS

Calculate Maximum Filtration Flow Rate: Pool Volume/ 360 = 48 GPM [if <13,000 MAY use 36 gpm]

**ANSI 15 Auxiliary Flow** MAY USE LESS THAN THIS MAXIMUM IF AT LEAST ANSI 5 12 HR TURNOVER

Calculate Maximum Auxiliary Load Design Flow Rate:  
Number Spa Jets X 7 to 15 GPM = X GPM

Or Water Feature Flow: X GPM X

**ANSI 15 Flow** ACTUAL TURNOVER AT ANSI 15 FLOW = 6.0 HR IF LESS THAN 12 HR MEETS ANSI 5

**ANSI 15 Flow :** 48 GPM [greater of **ANSI 15 Auxiliary Flows** and **ANSI 15 Filtration Flow** ]

**PUMP FROM APSP LISTING**

Select a pump with Curve A (pools <17,000 gal) or Curve C (pools >17,000 gal) flow equal to or less than **ANSI 15 Filtration Flow**. May select a multi speed pump with flows acceptable for the **ANSI 15 Auxiliary Flow**, with acceptable Curve A or C listed flows. Curve A or C flows listed have no relationship or requirement related to **ANSI 15 Auxiliary Flow**.

**Pump Make & Model:** PENTAIR INTELLIFLO

**Pump Flow Rate(s) from Listing:** @ Low/Single speed 15 GPM, & @ High Speed 101 GPM

**Pump Control:** Filtration Pump has no auxiliary load: X, time clock to be installed.

Filtration Pump with auxiliary load: Control for low speed default w/in 24 hrs: EASYTOUCH  
Make/model

**Size filter on "FILTRATION Flow"**

Filter Rates: Cartridge= 0.375 gpm/sf; Sand= 15 gpm/sf; DE= 2 gpm/sf

Filter size: **ANSI 15 Flow** 48 GPM / 0.375 gpm/sf = 127.0 SF Min Filter Size

[see pool plan for filter model or show here: PENTAIR CCRP200, 200 SF ]

**ANSI 7 Flow** see Site Specific Information Sheet

**ANSI 5 Flow:** Depending on the pipe, use any of the ANSI 15 Filtration, or ANSI 15 flows or the flow at 60 ft TDH on the selected pump curve for the **ANSI 5 Flow**.

See flow vs velocity vs pipe size on Standard Engineering.  
See summary of pipe sizes on ANSI 7 Site Specific Information Sheet

**HEATER MODEL:**

X  
GAS HEATER EFFICIENCY RATING: X with no pilot light [min 8%]  
X  
HEAT PUMP EFFICIENCY C.O.P.: X [min 4.0]





**PARAGON POOLS OF LAKE CITY**

Client of Kimes Engineering:

Owner: **DIOGENES & THERESA DUARTE**

Address: **673 SW BELL FLOWER DR**

**SITE SPECIFIC INFORMATION FOR COMPLIANCE WITH 2010 FBC ANSI/APSP-7**

**METHOD OF DETERMINING ANSI 7 PUMP FLOW**

Max Flow from Pump Curve Pump Curve Attached	<input type="checkbox"/>	Simplified TDH Curve & Calc	<input type="checkbox"/>	Detailed TDH Curve & Calc	<input checked="" type="checkbox"/>
---	--------------------------	--------------------------------	--------------------------	------------------------------	-------------------------------------

SUCTION OUTLET FOR: **FILTRATION PUMP**

Manufacturer & Model: **PENTAIR INTELLIFLO**

Pump Flow from Pump Curve with method indicated: **112 GPM**

Maximum Pump Flow for sizing Branch Pipe & Suction based on number of Suction Outlets used: **GPM**

Minimum Branch Pipe Size given flow at 6 FPS: **3 INCH**

LISTED SUCTION OUTLET COVER/GRATE- POOL OUTLET

Number of Suction Outlets: **TWO** Manufacturer & Model: **SDX**

APPROVED Maximum Outlet Flow (GPM) Floor flow: **200** Wall flow: **192**

TRUNK/SUCTION PIPE SIZING- ANSI 7 FLOW

Minimum Trunk Pipe Size given flow @ 8 FPS **2.5** Inch Pipe

SUCTION OUTLET FOR: **SPA**

Manufacturer & Model: **X**

Pump Flow from Pump Curve with method indicated: **GPM**

Maximum Pump Flow for sizing Branch Pipe & Suction based on number of Suction Outlets used: **X GPM**

Minimum Branch Pipe Size given flow at 6 FPS: **INCH**

LISTED SUCTION OUTLET COVER/GRATE- SPA OUTLETS

Number of Suction Outlets: **X** Manufacturer & Model: **X**

APPROVED Maximum Outlet Flow (GPM) Floor flow: **GPM** Wall flow: **GPM**

TRUNK/SUCTION PIPE SIZING- ANSI 7 FLOW

Minimum Trunk Pipe Size given flow @ 8 FPS **Inch Pipe**

ANSI 15 FLOW= **48 GPM**

**OTHER PIPE SIZE SUMMARY**

	SKIMMER SUCTION- ANSI 15 FLOW @ 6 FPS :	<b>2</b>	PIPE SIZE INCH
X GPM	FILTRATION RETURN SIDE-ANSI 15 FLOW @ 8 FPS:	<b>MIN 1 1/2</b>	FULL FLOW
X GPM	AUXILIARY RETURN SIDE- ANSI 5 FLOW @ 10 FPS:	<b>MIN</b>	ANSI SPLIT FLOW
	2 <sup>ND</sup> AUXILIARY RETURN SIDE- ANSI 5 FLOW @ 10 FPS:	<b>MIN</b>	
	OPTIONAL VACUUM OR SWEEP LINE- ANSI 5 FLOW @ 8 FPS:	<b>TYP 1-1/2</b>	

**NOTES:**

**SUMMARY: USE DUAL SDX DRAINS FOR POOL, WITH 3" BRANCH PIPE  
USE 2.5" SUCTION LINES TO PUMP**

- For Client Use Only -

© 2012 Kimes Engineering and Management Services, Inc.

3990 SR 64 E | Bradenton, Florida 34208 | ph: (941)749-0311

kent@kimesengineering.com | P.E. 33678, C.A. 27189



PROJECT CLIENT **PARAGON POOLS OF LAKE CITY**  
 PROJECT NAME **DIOGENES & THERESA DUARTE**  
 PROJECT ADDRESS **673 SW BELL FLOWER DR**

Pool ONLY	suction	pressure	equipment
Pipe Size	2.5	2	2
Pipe Length 100% flow	41	21	15
#El fittings	5	4	4
#T Run fittings	0	0	0
#T Branch fittings	1	0	1
Gate Valves	0	0	1
# 3 Way valves	0	0	2

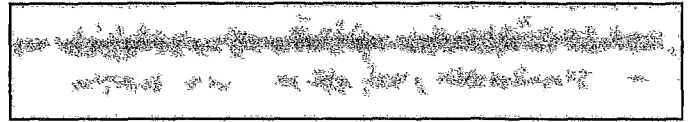

This calculation assumes worst case with 100% suction from drain and none from skimmer.  
 This calculation is conservative in that it omits the velocity head on the pressure side beyond the first split of return lines.

Filter: **PENTAIR CCRP200, 200 SF**

Head loss based on Hazen-Williams equation

Heater: **X**

Head Loss per 100 ft =  $0.2083 (100/c)^{1.852} * q^{1.852} / d_h^{4.8655}$

Return Fittings **3**

Using c= 140

SUM PIPE FRICTION HEAD	1.7	7.5	15.9	27.0	40.8	57.3
FILTER HEAD	0.0	0.4	1.7	3.7	6.5	9.3
RETURN FITTING FLOW	0.8	1.5	3.3	5.0	7.4	10.0
SALT CELL	0.0	7.0	1.4	2.3	3.3	4.3
HEATER	0.0	0.0	0.0	0.0	0.0	0.0
SUM TDH	3	16	22	38	58	81
FLOW	20	40	60	80	100	120

DETAILED TDH POOL MODE

Pump Curve **PENTAIR INTELLIFLO VS**

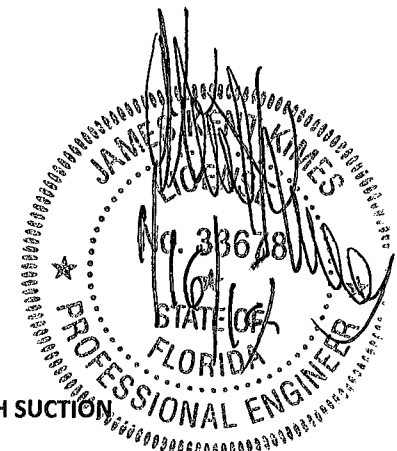
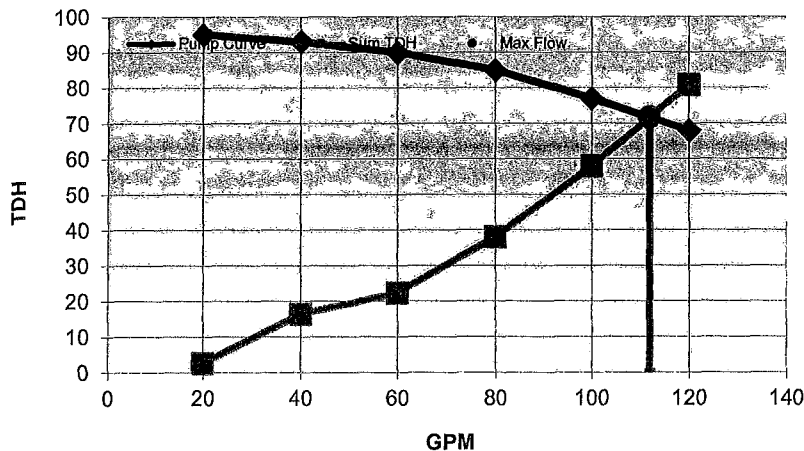

USE MINIMUM **2.5" BRANCH SUCTION**

MAXIMUM FLOW **112 GPM**  
 ANSI 7 SUCTION BRANCH: **3" MIN IF MULTIPLE OUTLETS- OMIT FOR UNBLOCKABLE OUTLETS**  
 ANSI 7 SUCTION TO EQUIP: **2.5" TRUNK SUCTION TO EQUIPMENT**

- For Client Use Only -

© 2012 **Kimes Engineering and Management Services, Inc.**

3990 SR 64 E | Bradenton, Florida 34208 | ph: (941)749-0311

kent@kimesengineering.com | P.E. 33678, C.A. 27189

## IntelliFlo® Variable Speed High Performance Pump (Cont'd)

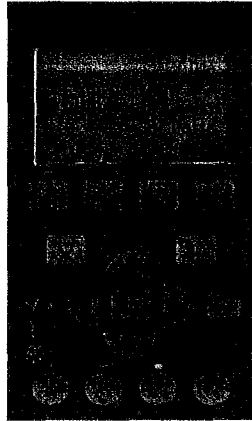

Keypad for IntelliFlo Variable Speed

### Dimensions and Performance\*

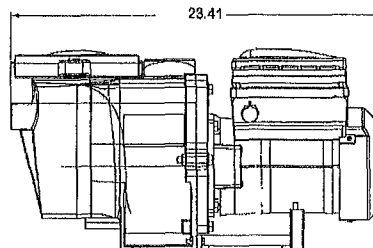
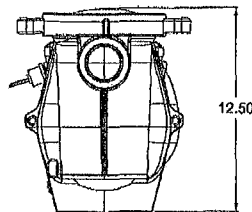
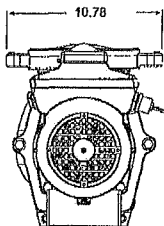
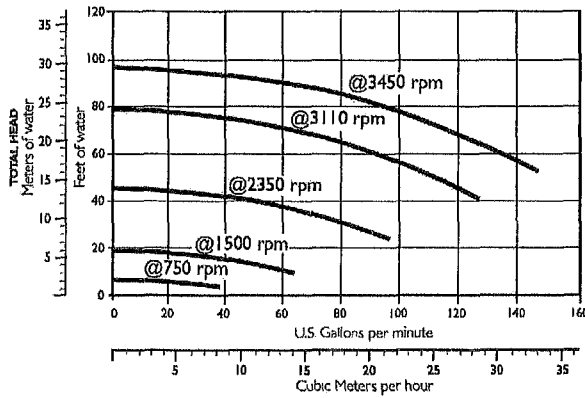

Refer to catalog page 35 for a selection of 1-and-2-Pole GFCI breakers which offer 6 millamp personnel protection while meeting NEC 2008 Standards for Pool Pumps.

\* See page 477 for replacement parts

# DIOGENES & THERESA DUARTE

With a flow rating of 200 gpm on the floor and 192 gpm on the wall SDX is compatible with pumps up to 3 hp. In most cases this eliminates the need to calculate the system total dynamic head.

DESCRIPTION	MAX FLOW FLOOR	MAX FLOW WALL
One SDX Drain	200 gpm (756 lpm)	192 gpm (726 lpm)
Two SDX Drains	200 gpm (756 lpm)	192 gpm (726 lpm)
Three SDX Drains	300 gpm (1136 lpm)	288 gpm (1090 lpm)
Four SDX Drains	400 gpm (1514 lpm)	384 gpm (1456 lpm)

- Order **SDX** for new pool construction or when installing a new plaster ring (such as when a new interior finish is being applied)
- **SDX** is available for concrete, vinyl and fiberglass pools
- Order **SDX Retro** when replacing an existing suction outlet cover up to 10" in diameter
- **SDX Retro** is available for concrete and vinyl pools
- **SDX Equalizer** for skimmer equalizer lines or suction pipes extending through the wall of concrete pools without sumps. Spacer ring provides adequate clearance to eliminate chipping of interior surface to create a sump. Includes concrete anchors.

Available in eight colors to complement any interior surface



WARNING: SDX and SDX Retro must be installed in accordance with Paramount's written instruction manual and in conformity with applicable Federal, State, Local and Swimming Pool Industry building and safety codes.

  
**Paramount**  
 Pool Life. Simplified.

World's #1 In-Floor Systems Company

295 East Corporate Place, Suite 100  
 Chandler, Arizona 85225

480.893.7607 | 1.800.621.5886 | www.1Paramount.com  
 Paramount@1Paramount.com

SDX & SDX Retro are Protected by U.S. Patent Numbers  
 7,176,179 D,532,684 D,531,668

SDX0614 004-022-5830-00 REV060711



VGB HIGH FLOW SAFETY DRAIN

**THE ONLY PATENTED  
 "NO SUMP NEEDED"  
 10" SAFETY DRAIN**

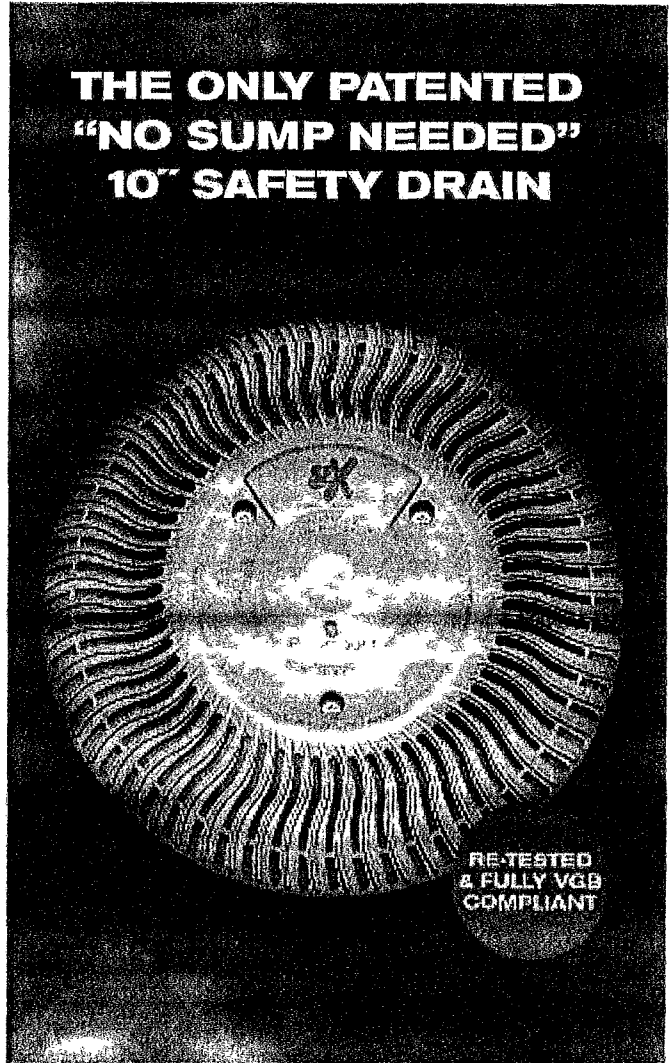

Powered by  
**Paramount**  
 Pool Life. Simplified.

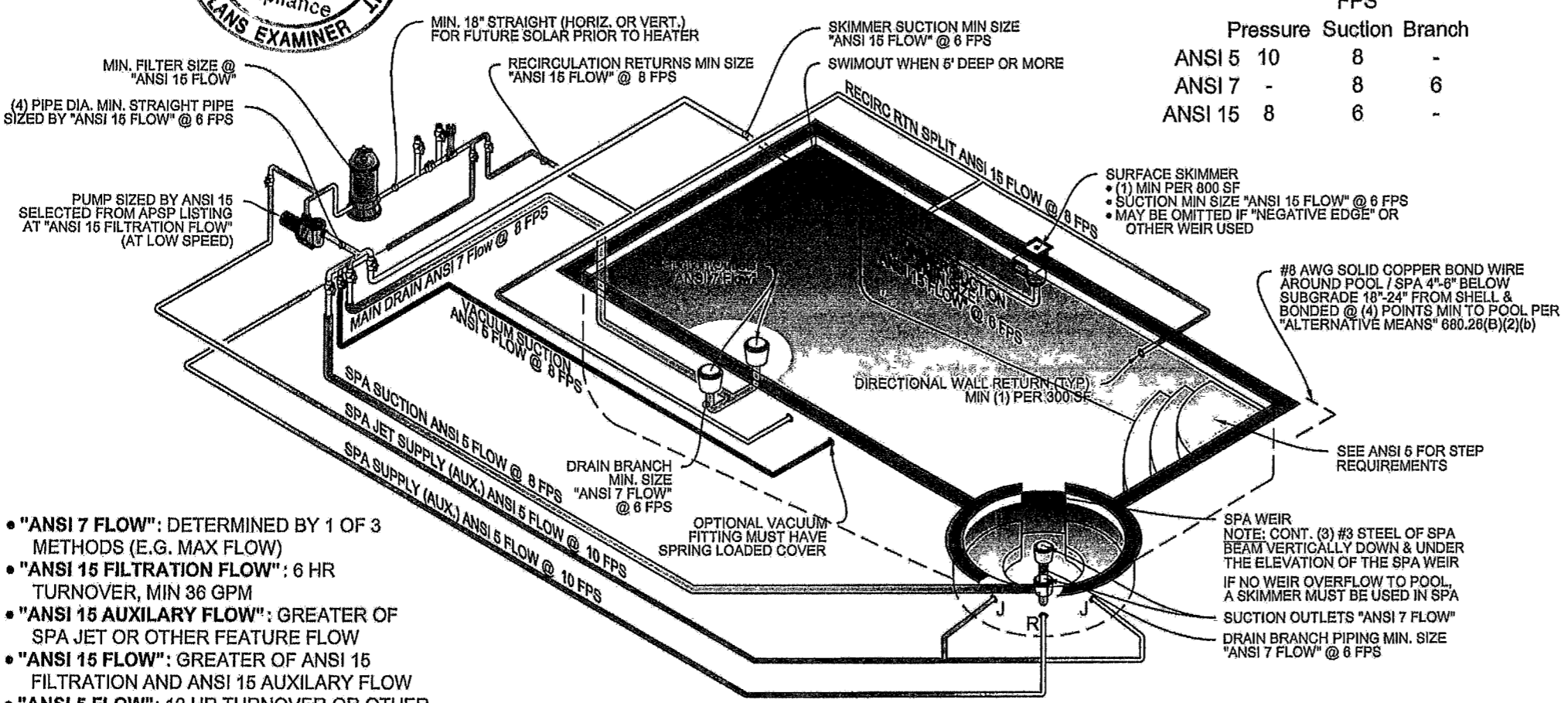
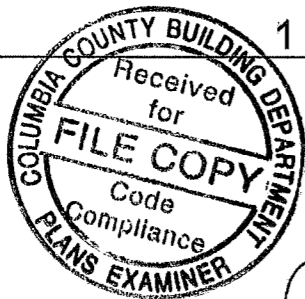

	FPS	Pressure	Suction	Branch
ANSI 5	10	8	-	
ANSI 7	-	8	6	
ANSI 15	8	6	-	

- "ANSI 7 FLOW": DETERMINED BY 1 OF 3 METHODS (E.G. MAX FLOW)
- "ANSI 15 FILTRATION FLOW": 6 HR TURNOVER, MIN 36 GPM
- "ANSI 15 AUXILARY FLOW": GREATER OF SPA JET OR OTHER FEATURE FLOW
- "ANSI 15 FLOW": GREATER OF ANSI 15 FILTRATION AND ANSI 15 AUXILARY FLOW
- "ANSI 5 FLOW": 12 HR TURNOVER OR OTHER "ESTIMATED/ DESIGN" FLOW

**NOTES:**

- This plan is schematic & piping shall be connected to provide a functioning system.
- Pool piping shall hold a static water or air pressure not less than 35 psi for 15 minutes, per R4101.12.1
- Pools shall have pumps selected to provide minimum 12 hr. turnover & maximum 6 hour turnover.
- Determine pipe sizing from attached work sheets.
- Spa piping determined from attached work sheets.
- The dual main drains shall have a minimum separation of 3 ft, unless one is located on the vertical wall or a single unblockable drain is used.
- All suction covers shall meet ANSI/ASME A112.19.8-2007
- All piping shall be NSF-PW approved & meet the requirements of Florida Building Code.
- Electrical equipment, wiring, & installation shall conform to the National Electrical Code 2008 Edition
- Bonding of pool steel & light to footing steel shall be continued to & include all pumps & heaters.
- Temporary fencing shall be installed & maintained until permanent child safety features are installed.
- There shall be a passing electrical & child safety final inspection prior to filling the pool or spa with water.
- Pool shall meet the applicable criteria in ANSI/APSP 3,4,5,6, 7 & 15 standards.
- Regardless of the criteria here, the project shall comply with all sections of the FBC - Residential, Building, Mechanical, Plumbing & Gas Codes, as applicable respectively & amended.

SEE INFORMATION ATTACHED TO THIS PERMIT PACKAGE FOR SITE SPECIFIC DETAILS SHOWING ANSI 7 & 15 AND FBC COMPLIANCE

INFORMATION ON THIS SHEET COMPLIES WITH 2010 FBC INCLUDING 2010 FBC ENERGY CONSERVATION CODE

673 SW BELLFLOWER DR

**KIMES ENGINEERING**  
 AND MANAGEMENT SERVICES, INC  
 13410 2nd Ave. NE, Bradenton, FL 34212  
 Office: 941-749-0311, Fax: 941-746-7391  
 kent@kimesengineering.com  
 P.E. 33678, C.A. 27189

This drawing is the property of Kimes Engineering & Management Services, Inc. & is not to be reproduced or copied in whole or in part. It is only for the project & site specifically identified herein & is not to be used on any other project. It is to be returned upon request.

DATE:	REVISIONS:
DWG. BY: MCM	PRINTED: 13-Apr-12
CHKD. BY: JKK	SCALE: AS NOTED
DATE: 13-Apr-12	

TYPICAL PLAN & SECTIONS FOR RESIDENTIAL POOL/SPA

POOL ONLY

SPA ONLY

**S1**

SHEET OF

PIPE FLOW AT GIVEN VELOCITY (GPM)

PIPE	6 FPS	8 FPS	10 FPS
1"	16	22	26
1-1/2"	38	51	62
2"	63	84	102
2-1/2"	90	119	146
3"	138	184	226
4"	238	317	391
6"	540	720	890

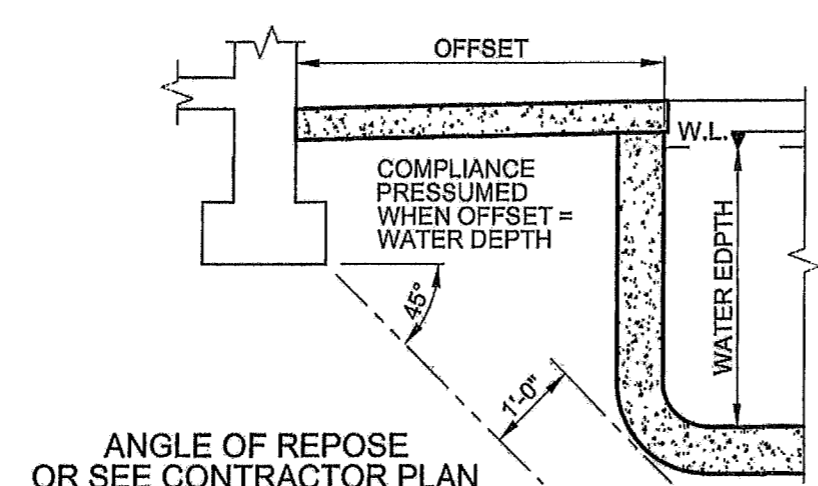

**EXAMPLE RESIDENTIAL POOL / SPA SCHEMATIC PLAN & NOTES**

SCALE: N.T.S.

\\BSDDC\Company Shared Docs\File Cabinet-Kent\Pool Changes 2011 & 2012\11-2010 KE Std Eng r 4-13-12.dwg

\\SBSDC\Company Shared Docs\Kent\1 Pool Changes 2011 & 2012\1-2010 KE Std Eng r 4-13-12.dwg

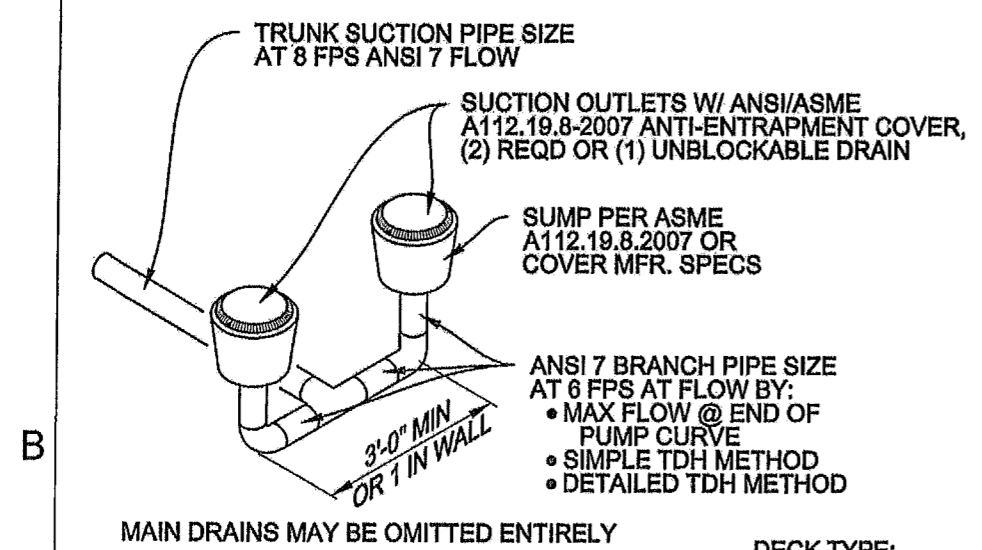

MAIN DRAINS MAY BE OMITTED ENTIRELY

**DECK TYPE:**  
 CONCRETE  
 6x6 W.W.M.  
 FIBERMESH  
 PAVERS  
 4" DECK W/ NON-SLIP FINISH SLOPED AWAY FROM POOL 2%-4% (TYP)  
 (3) #3 REBAR BUNDLED AT RIM OF POOL & SPA. CONT. #3 STL. OF SPA BEAM VERT. DOWN & UNDER ELEV. OF SPA WEIR. [OPTION:] CONTRACTORS MAY CHOOSE TO USE (3) #3 BARS WITHIN TOP OF BEAM SPACED 1" APART + OR -

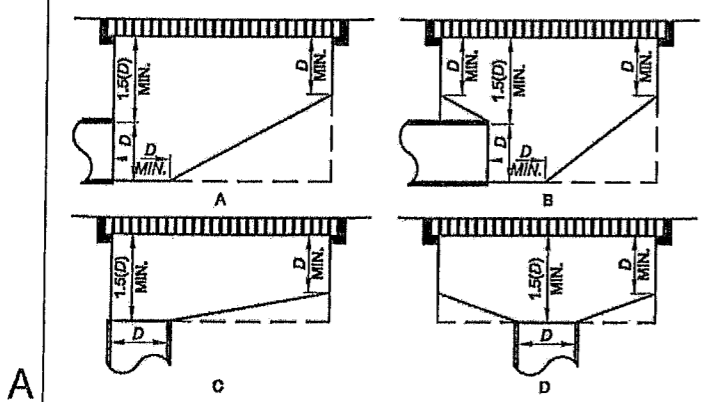

**GENERAL NOTES:**  
 a. D = INSIDE DIA. OF PIPE  
 b. ALL DIMENSIONS SHOWN ARE MINIMUMS.  
 c. ALL HIDDEN LINES INDICATE SUGGESTED SUMP CONFIGURATIONS.  
**NOTES:**  
 • FIELD BUILD SUMPS MEETING THESE CRITERIA REQD WHEN MFR POTS NOT USED  
 • MAY OMIT IF LISTED COVER DOCUMENTATION STATES OTHER CLEARANCE TO SUCTION PIPE REQD

**SUMP SECTIONS PER ASME A112.19.8-2007**  
 SCALE: N.T.S.

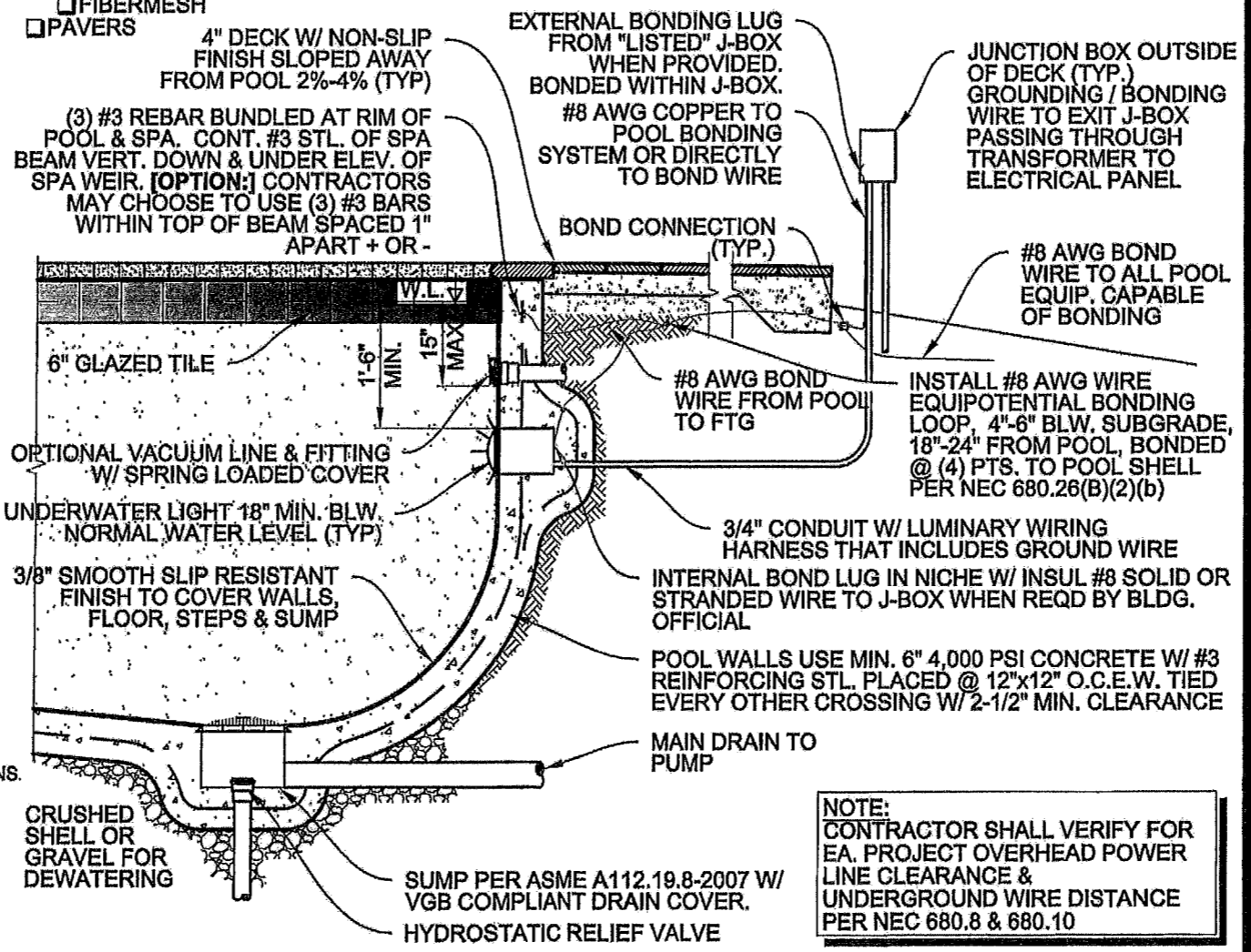

**POOL DEEP END SECTION**  
 SCALE: N.T.S.

**NOTE:**  
 CONTRACTOR SHALL VERIFY FOR EA. PROJECT OVERHEAD POWER LINE CLEARANCE & UNDERGROUND WIRE DISTANCE PER NEC 680.8 & 680.10

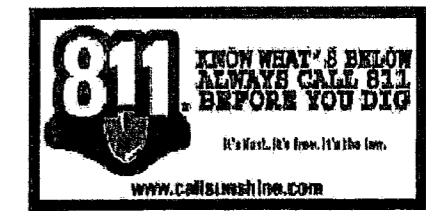

**NOTE**

1. APPROVED PRODUCT SPECIFICATION MAY DIFFER FROM FIELD BUILT SUMPS SHOWN ON THIS PAGE

**ADDITIONAL STRUCTURAL NOTES**

- Use minimum ASTM A815 Grade 40 Steel
- Lap #3 bars minimum 15"
- Lap #5 bars minimum 25"
- 6" Shell thickness and 2-1/2" concrete coverage are minimums
- Use 4,000 psi concrete
- Contractor / Owner required to:
  - Contact Engineer if pool not placed on undisturbed and de-watered earth that can meet 2,000 psf bearing capacity.
  - When buried debris is encountered or questionable conditions are indicated at the work site prior / during construction, a subsurface consultant shall conduct boring(s) in the area of the pool to confirm soil bearing capacity, clear of buried debris, & verifying ground water level
  - All modified soils & earth fill under perspective pool area shall meet a soil density and compaction minimum of 95% modified proctor without settlement.

INFORMATION ON THIS SHEET COMPLIES WITH 2010 FBC INCLUDING 2010 FBC ENERGY CONSERVATION CODE

673 SW BELLFLOWER DR

**KIMES ENGINEERING**  
 LAND MANAGEMENT SERVICES, INC  
 13410 2nd Ave. NE, Bradenton, FL 34212  
 Office: 941-749-0311, Fax: 941-746-7391  
 kent@kimesengineering.com  
 P.E. 33678, C.A. 27189

©2010 Kimes Engineering & Management Services, Inc. This drawing is the property of Kimes Engineering & Management Services, Inc. and is not to be reproduced or copied in whole or in part. It is only for the project & site specifically identified hereon, and is not to be used on any other project. It is to be returned upon request.

DATE:	REVISIONS:
DWG. BY: MCM	PRINTED: 13-Apr-12
CHKD. BY: JKK	SCALE: AS NOTED
DATE: 13-Apr-12	

**TYPICAL PLAN & SECTIONS FOR RESIDENTIAL POOL/SPA**

**S2**

SHEET OF