

COLUMBIA COUNTY Property Appraiser

Parcel 26-5S-16-03717-134

Owners

REGISTER MIRANDA
259 SW DEWEY CT
FORT WHITE, FL 32038

GSA GIS

Pictometry

Parcel Summary

Location	259 SW DEWEY CT
Use Code	0200: MOBILE HOME
Tax District	3: COUNTY
Township	5S
Section	26
Range	16
Acreage	5.0100
Subdivision	BIG OAKS

Legal Description

N 1/2 OF LOT 7 BIG OAKS S/D UNREC: COMM NE COR,
RUN W 784.29 FT, S 1153.19 FT, W 760.58 FT FOR
POB, RUN S 573.34 FT, W 380.29 FT, N 573.34 FT,
E 380.29 FT TO POB.

789-1356, 798-2659, 955-1668, QC 1057-1230,
PB 1507-1839,1852, PB 1521-2244, WD 1529-1605,

Working Values

	2025
Total Building	\$10,466
Total Extra Features	\$8,900
Total Market Land	\$50,100
Total Ag Land	\$0

	2025
Total Market	\$69,466
Total Assessed	\$69,466
Total Exempt	\$0
Total Taxable	\$69,466
SOH Diff	\$0

Value History

	2024	2023	2022	2021	2020	2019
Total Building	\$30,525	\$27,748	\$21,643	\$18,315	\$15,221	\$14,508
Total Extra Features	\$8,900	\$8,900	\$5,150	\$1,900	\$1,900	\$1,900
Total Market Land	\$50,100	\$42,585	\$37,575	\$33,310	\$33,003	\$33,003
Total Ag Land	\$0	\$0	\$0	\$0	\$0	\$0
Total Market	\$89,525	\$79,233	\$64,368	\$53,525	\$50,124	\$49,411
Total Assessed	\$89,525	\$49,323	\$47,886	\$46,491	\$45,849	\$44,818
Total Exempt	\$0	\$25,000	\$25,000	\$25,000	\$25,000	\$25,000
Total Taxable	\$89,525	\$24,323	\$22,886	\$21,491	\$20,849	\$19,818
SOH Diff	\$0	\$29,910	\$16,482	\$7,034	\$4,275	\$4,593

Document/Transfer/Sales History

Instrument / Official Record	Date	QU	Reason	Type	V/I	Sale Price	Ownership
<u>WD</u> 1529/1605	2024-12-10	<u>Q</u>	<u>01</u>	WARRANTY DEED	Improved	\$95,000	Grantor: SADLER MICHAEL BRENT Grantee: REGISTER MIRANDA
<u>PB</u> 1507/1839	2024-02-05	<u>U</u>	<u>18</u>	PROBATE	Improved	\$0	Grantor: CLERK OF COURT (COOK MARTHA J ESTATE) Grantee: SADLER MICHAEL BRENT AKA BRENT SADLER
<u>WD</u> 1057/1230	2005-09-07	<u>Q</u>	<u>06</u>	WARRANTY DEED	Improved	\$100	Grantor: E F WOODY COOK Grantee: MARTHA J COOK
<u>WD</u> 0955/1668	2002-05-24	<u>Q</u>	<u>01</u>	WARRANTY DEED	Vacant	\$100	Grantor: CHARLES & SHARON SADLER Grantee: E F WOODY & MARTHA J COOK

Buildings

Building # 1, Section # 1, 15221, MOBILE HOME

Type	Model	Heated Sq Ft	Repl Cost New	YrBlt	WAY	Other % Dpr	Normal % Dpr	% Cond	Value
0800	02	1352	\$52,329	1990	1990	20.00%	80.00%	20.00%	\$10,466

Structural Elements

Type	Description	Code	Details
EW	Exterior Wall	08	WD OR PLY
RS	Roof Structure	03	GABLE/HIP
RC	Roof Cover	03	COMP SHNGL
IW	Interior Wall	05	DRYWALL
IF	Interior Flooring	14	CARPET
IF	Interior Flooring	08	SHT VINYL
AC	Air Conditioning	03	CENTRAL
HT	Heating Type	04	AIR DUCTED
BDR	Bedrooms	3.00	
BTH	Bathrooms	2.00	
STR	Stories	1.	1.
AR	Architectual Type	01	CONV
UT	Units	0.00	
COND	Condition Adjustment	01	01
KTCH	Kitchen Adjustment	01	01

Subareas

Type	Gross Area	Percent of Base	Adjusted Area
BAS	1,352	100%	1,352
FOP	40	35%	14
FSP	150	40%	60
UOP	120	25%	30

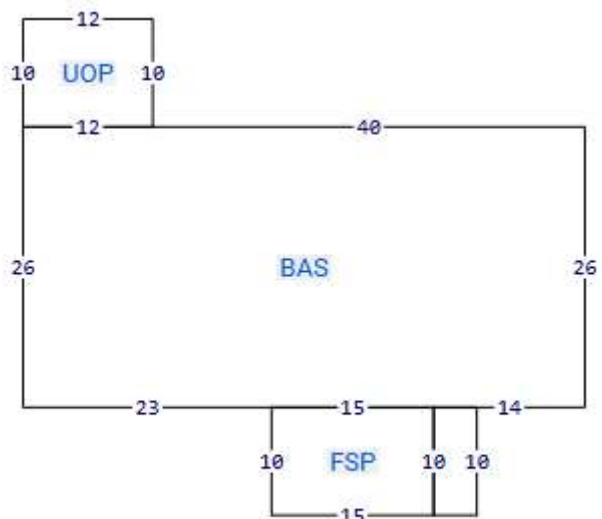

Extra Features

Code	Description	Length	Width	Units	Unit Price	AYB	% Good Condition	Final Value
0190	FPLC PF			1.00	\$1,200	2002	100%	\$1,200
0296	SHED METAL			1.00	\$0	2009	100%	\$700
9945	Well/Sept			1.00	\$7,000		100%	\$7,000

Land Lines

Code	Description	Zone	Front	Depth	Units	Rate/Unit	Acreage	Total Adj	Value
0200	MBL HM	A-1	.00	.00	5.01	\$10,000.00/AC	5.01	1.00	\$50,100

Personal Property

None

Permits

None

TRIM Notices

2022
2023
2024

Disclaimer

All parcel data on this page is for use by the Columbia County Assessor for assessment purposes only. The summary data on this page may not be a complete representation of the parcel or of the improvements thereon. Building information, including unit counts and number of permitted units, should be verified with the appropriate building and planning agencies. Zoning information should be verified with the appropriate planning agency. All parcels are reappraised each year. This is a true and accurate copy of the records of the Columbia County Assessor's Office as of January 08, 2025.