

⊗ Dia= 5/8"
 ⊕ Dia= 3/4"

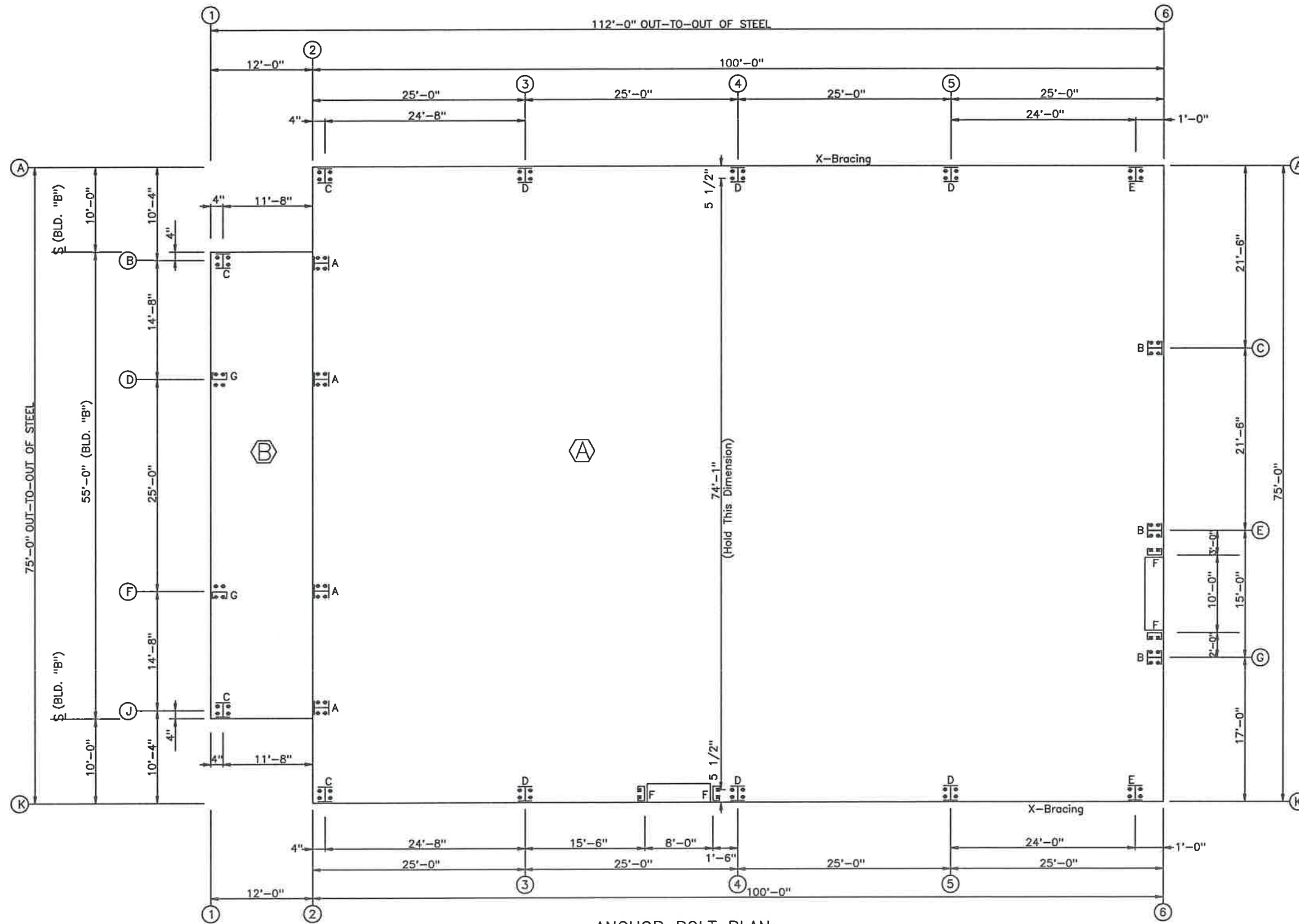

ANCHOR BOLT PLAN
 NOTE: All Base Plates @ 100'-0" (Unless Noted)

NOTE: ALL FIELD LOCATED FRAMED OPENING LOCATIONS SHALL BE AT THE DISCRETION OF THE ERECTOR/CUSTOMER. IT IS RECOMMENDED THAT THESE ANCHORS BE LOCATED AT TIME OF ERECTION.

FIELD LOCATE:
 (5) 3070 WALKDOORS
 (7) 3'-0" x 5'-0" FRAMED OPENING

ISSUE	DET	CHK	DATE
UNION LaSTEEL			
CUSTOMER: TRAFICANTE			
JOB NO: 8728	DATE: 8/14/24		
LOCATION: LAKE CITY, FL 32025			
DRAWING NAME: ANCHOR BOLT LAYOUT			
DRAWING NO: PAGE 1	DRAWN BY: PS	CHECKED BY: SPW	SCALE: NONE

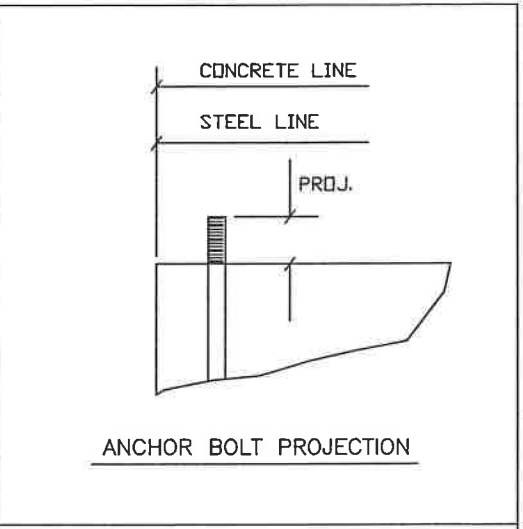
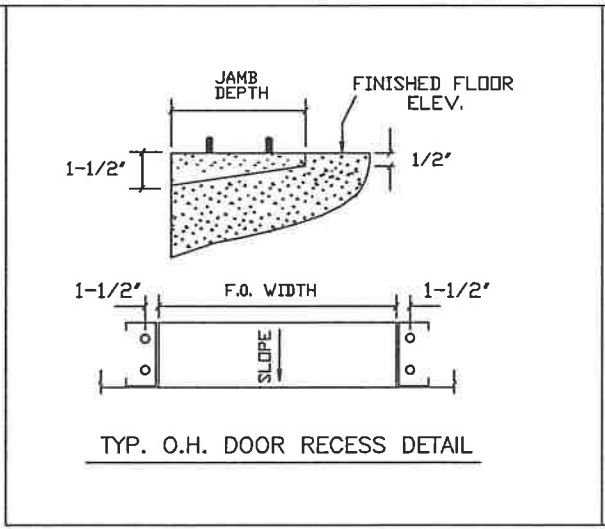
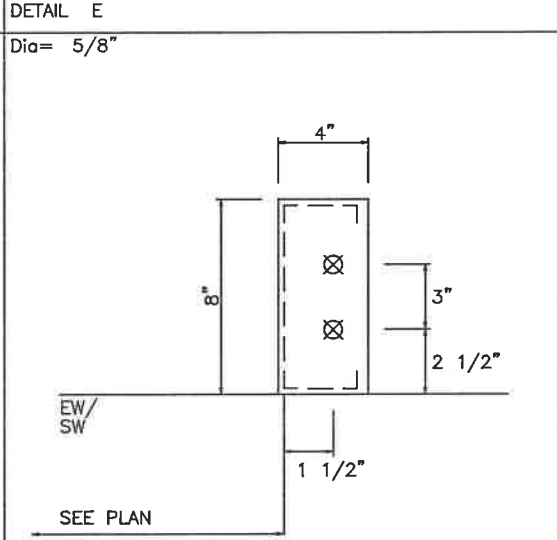
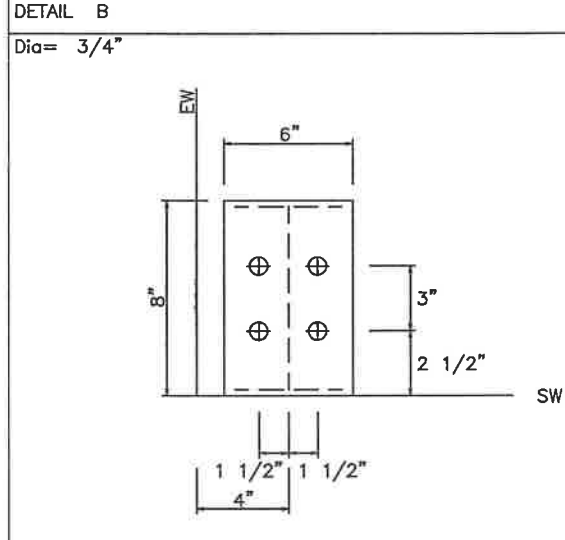
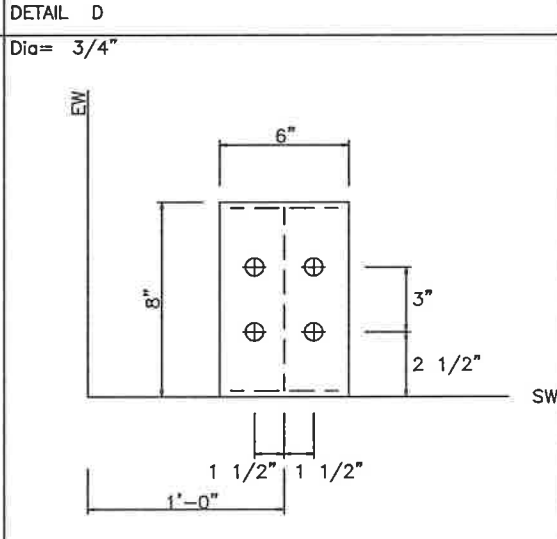
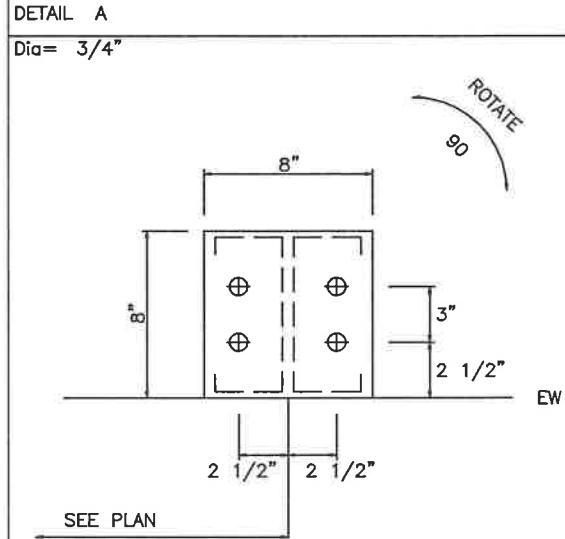
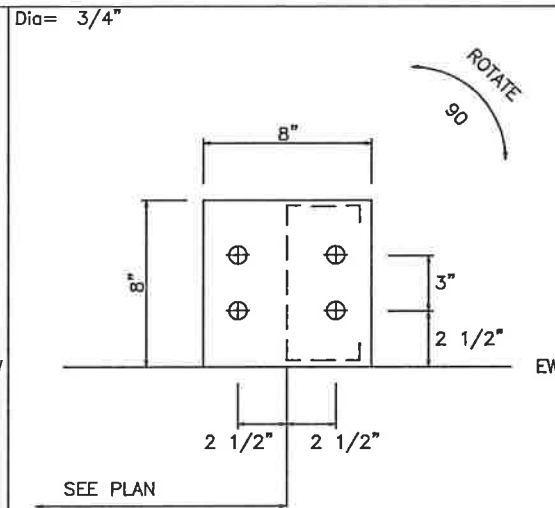
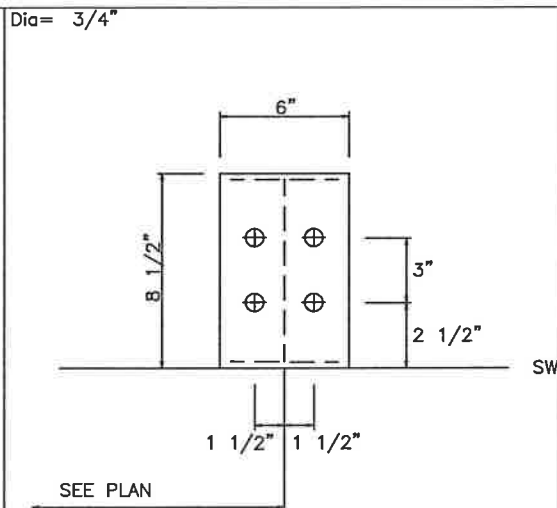
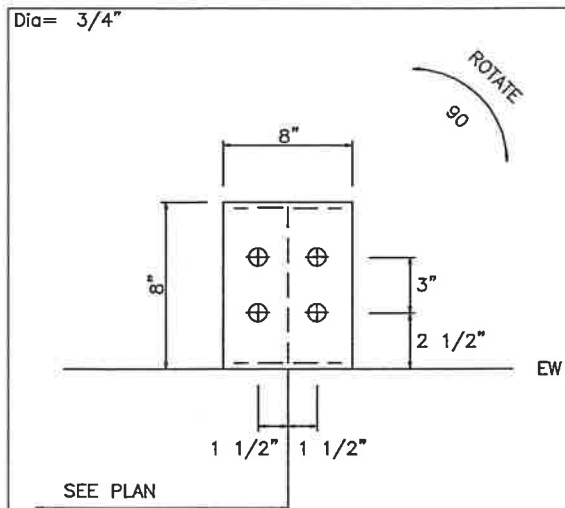

ISSUE	DET	CHK	DATE
UNION LoSTEEL			
CUSTOMER: TRAFICANTE			
JOB NO: 8728	DATE: 8/14/24		
LOCATION: LAKE CITY, FL 32025			
DRAWING NAME: ANCHOR BOLT DETAILS			
DRAWING NO: PAGE 1.1	DRAWN BY: PS	CHECKED BY: SPW	SCALE: NONE

FRAME LINES: 2 3 4 5 6

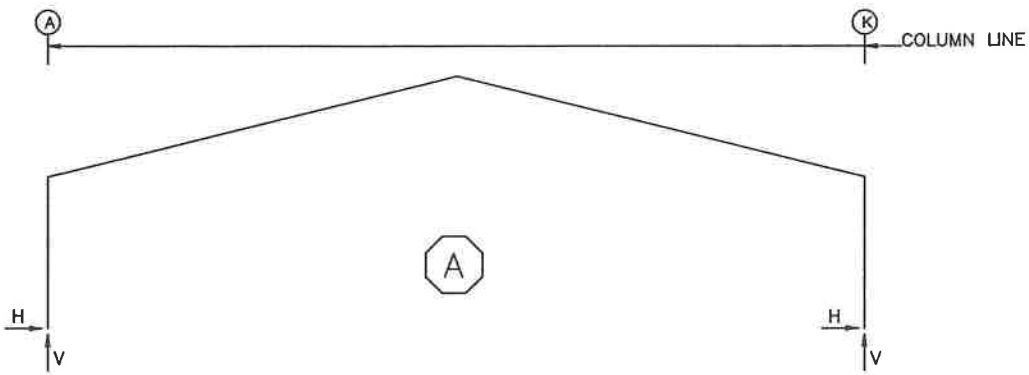

RIGID FRAME: ANCHOR BOLTS & BASE PLATES

Frm Line	Col Line	Anc. Bolt Qty	Anc. Bolt Dia	Base Plate (in)			Grout (in)
				Width	Length	Thick	
2	A	4	0.750	6.000	8.000	0.500	0.0
2	K	4	0.750	6.000	8.000	0.500	0.0

RIGID FRAME: ANCHOR BOLTS & BASE PLATES

Frm Line	Col Line	Anc. Bolt Qty	Anc. Bolt Dia	Base Plate (in)			Grout (in)
				Width	Length	Thick	
3*	A	4	0.750	6.000	8.500	0.500	0.0
3*	K	4	0.750	6.000	8.500	0.500	0.0

3* Frame lines: 3 4 5

RIGID FRAME: ANCHOR BOLTS & BASE PLATES

Frm Line	Col Line	Anc. Bolt Qty	Anc. Bolt Dia	Base Plate (in)			Grout (in)
				Width	Length	Thick	
6	A	4	0.750	6.000	8.000	0.375	0.0
6	K	4	0.750	6.000	8.000	0.375	0.0

ENDWALL COLUMN: BASIC COLUMN REACTIONS (k)

Frm Line	Col Line	Dead Vert	Collat Vert	---Live---		Snow Vert	Snow Drift Vert	Wind_Left1		Wind_Right1		Wind Left2 Vert	Wind Right2 Vert
				Horz	Vert			Horz	Vert	Horz	Vert		
2	B	0.2	0.0	0.0	0.6	0.1	0.1	0.0	-0.3	0.0	-0.2	0.1	0.1
2	D	0.6	0.1	-0.1	2.8	0.4	0.6	0.1	-1.7	0.1	-1.5	-0.9	-0.8
2	F	0.6	0.1	-0.1	2.8	0.4	0.6	0.1	-1.5	0.1	-1.7	-0.8	-0.9
2	J	0.2	0.0	0.0	0.6	0.1	0.1	0.0	-0.2	0.0	-0.3	0.1	0.1
6	G	0.1	0.0	0.0	0.0	0.0	0.0	0.0	0.0	0.0	0.0	0.0	0.0
6	E	0.2	0.0	0.0	0.0	0.0	0.0	0.0	0.0	0.0	0.0	0.0	0.0
6	C	0.1	0.0	0.0	0.0	0.0	0.0	0.0	0.0	0.0	0.0	0.0	0.0

Frm Line	Col Line	Wind Press Horz	Wind Suct Horz	Wind_Long1		Wind Long2 Vert	Seis Left Vert	Seis Right Vert	Seis Long Vert
				Horz	Vert				
2	B	-0.7	0.8	0.0	-0.8	-0.1	0.0	0.0	0.0
2	D	-0.1	0.1	0.1	-2.7	0.1	0.0	0.0	0.0
2	F	-0.1	0.1	0.1	-2.7	0.1	0.0	0.0	0.0
2	J	-0.7	0.8	0.0	-0.8	-0.1	0.0	0.0	0.0
6	G	-2.5	2.7	0.0	0.0	0.0	0.0	0.0	0.0
6	E	-3.4	3.8	0.0	0.0	0.0	0.0	0.0	0.0
6	C	-3.5	3.9	0.0	0.0	0.0	0.0	0.0	0.0

BUILDING BRACING REACTIONS

Wall Loc	Col Line	± Reactions(k)				Panel Shear (lb/ft)		Note
		Wind Horz	Wind Vert	Seismic Horz	Seismic Vert	Wind	Seis	
L_EW	2							(h)
F_SW	K	5,6	6.1	3.1	0.8	0.4		(h)
R_EW	6							
B_SW	A	5,4	5.7	2.8	0.7	0.4		

(h) Rigid frame at endwall

Reactions for seismic represent shear force, Eh
Reaction values shown are unfactored

RIGID FRAME: BASIC COLUMN REACTIONS (k)

Frame Line	Column Line	---Dead---		---Collateral---		---Live---		---Snow---		---Wind_Left1---		---Wind_Right1---	
		Horz	Vert	Horz	Vert	Horz	Vert	Horz	Vert	Horz	Vert	Horz	Vert
2	A	1.7	2.3	0.3	0.4	6.9	8.5	1.8	2.2	-14.2	-16.9	-8.4	-13.1
2	K	-1.7	2.5	-0.3	0.4	-6.9	10.1	-1.8	2.5	8.2	-13.9	13.6	-19.3
Frame Line	Column Line	---Wind_Left2---		---Wind_Right2---		---Wind_Long1---		---Wind_Long2---		---Seismic_Left---		---Seismic_Right---	
		Horz	Vert	Horz	Vert	Horz	Vert	Horz	Vert	Horz	Vert	Horz	Vert
2	A	-11.2	-11.3	-5.4	-7.5	-5.8	-12.0	-7.0	-10.1	-0.2	-0.1	0.2	0.1
2	K	5.1	-8.3	10.6	-13.8	7.0	-10.1	5.8	-12.0	-0.2	0.1	0.2	-0.1
Frame Line	Column Line	---MIN_SNOW---		F1UNB_SL_L---		F1UNB_SL_R---							
		Horz	Vert	Horz	Vert	Horz	Vert	Horz	Vert	Horz	Vert	Horz	Vert
2	A	2.3	2.9	1.4	2.0	1.4	1.2						
2	K	-2.3	3.2	-1.4	1.3	-1.4	2.3						
Frame Line	Column Line	---Dead---		---Collateral---		---Live---		---Snow---		---Wind_Left1---		---Wind_Right1---	
		Horz	Vert	Horz	Vert	Horz	Vert	Horz	Vert	Horz	Vert	Horz	Vert
3*	A	2.1	2.8	0.4	0.5	9.1	11.2	2.4	2.9	-14.7	-16.8	-7.1	-13.2
3*	K	-2.1	3.0	-0.4	0.5	-9.1	13.3	-2.4	3.3	6.9	-14.0	14.1	-19.4
Frame Line	Column Line	---Wind_Left2---		---Wind_Right2---		---Wind_Long1---		---Wind_Long2---		---Seismic_Left---		---Seismic_Right---	
		Horz	Vert	Horz	Vert	Horz	Vert	Horz	Vert	Horz	Vert	Horz	Vert
3*	A	-11.2	-9.5	-3.7	-5.8	-7.6	-15.8	-9.2	-13.3	-0.2	-0.1	0.2	0.1
3*	K	3.4	-6.6	10.6	-12.0	9.2	-13.3	7.6	-15.8	-0.2	0.1	0.2	-0.1
Frame Line	Column Line	---MIN_SNOW---		F2UNB_SL_L---		F2UNB_SL_R---							
		Horz	Vert	Horz	Vert	Horz	Vert	Horz	Vert	Horz	Vert	Horz	Vert
3*	A	3.0	3.7	1.9	2.7	1.9	1.6						
3*	K	-3.0	4.2	-1.9	1.8	-1.9	3.0						
Frame Line	Column Line	---Dead---		---Collateral---		---Live---		---Snow---		---Wind_Left1---		---Wind_Right1---	
		Horz	Vert	Horz	Vert	Horz	Vert	Horz	Vert	Horz	Vert	Horz	Vert
6	A	1.2	1.8	0.2	0.3	4.5	5.8	1.2	1.5	-9.4	-11.6	-5.4	-9.0
6	K	-1.2	1.9	-0.2	0.3	-4.5	6.9	-1.2	1.7	5.2	-9.5	9.0	-13.2
Frame Line	Column Line	---Wind_Left2---		---Wind_Right2---		---Wind_Long1---		---Wind_Long2---		---Seismic_Left---		---Seismic_Right---	
		Horz	Vert	Horz	Vert	Horz	Vert	Horz	Vert	Horz	Vert	Horz	Vert
6	A	-7.4	-7.8	-3.4	-5.1	-3.7	-8.2	-4.6	-6.9	-0.1	0.0	0.1	0.0
6	K	3.2	-5.7	7.0	-9.4	4.6	-6.9	3.7	-8.2	-0.1	0.0	0.1	0.0
Frame Line	Column Line	---MIN_SNOW---		F3UNB_SL_L---		F3UNB_SL_R---							
		Horz	Vert	Horz	Vert	Horz	Vert	Horz	Vert	Horz	Vert	Horz	Vert
6	A	1.5	1.9	0.9	1.4	0.9	0.8						
6	K	-1.5	2.2	-0.9	0.9	-0.9	1.5						

ENDWALL COLUMN: ANCHOR BOLTS & BASE PLATES

Frm Line	Col Line	Anc. Bolt Qty	Anc. Bolt Dia	Base Plate (in)			Grout (in)
				Width	Length	Thick	
2	B	4	0.750	8.000	8.000	0.250	0.0
2	D	4	0.750	8.000	8.000	0.250	0.0
2	F	4	0.750	8.000	8.000	0.250	0.0
2	J	4	0.750	8.000	8.000	0.250	0.0
6	G	4	0.750	8.000	8.000	0.250	0.0
6	E	4	0.750	8.000	8.000	0.250	0.0
6	C	4	0.750	8.000	8.000	0.250	0.0

ANCHOR BOLT SUMMARY

Qty	Locate	Dia (in)	Type	Projection (in)
8	Jamb	5/8"	A307	1.50
28	Endwall	3/4"	GR36	1.50
40	Frame	3/4"	GR36	2.50

GENERAL NOTES

- FOUNDATION DESIGN AND CONSTRUCTION ARE NOT THE RESPONSIBILITY OF METAL BUILDING MANUFACTURER.
- ALL REACTIONS ARE UNFACTORED.
- ULTIMATE WIND LOADS ARE USED TO DERIVE THE WIND REACTION.
- ANCHOR BOLTS SHALL BE ACCURATELY SET TO A TOLERANCE OF +/- 1/8" IN BOTH ELEVATION AND LOCATION.
- COLUMN BASE PLATES ARE DESIGNED NOT TO EXCEED A BEARING PRESSURE OF 1050 POUNDS PER SQUARE INCH.

NOTE: THE FRAMING AT BOTH ENDWALLS IS NOT DESIGNED TO ACCOMMODATE FUTURE ADDITIONS. REACTIONS CORRESPONDING TO THESE FRAME LINES REFLECT LOADINGS FOR ACTUAL TRIBUTARY AREA AND ARE NOT INTENDED TO INCLUDE ANY FUTURE MODIFICATIONS UNLESS NOTED OTHERWISE.

NOTES FOR REACTIONS

Building reactions are based on the following building data:

- Width (ft) = 75.0
- Length (ft) = 100.0
- Eave Height (ft) = 14.0 / 14.0
- Roof Slope (rise/run) = 3.00 / 3.00
- Roof Dead Load (psf) = 2.0
- Wall Dead Load (psf) = 2.0
- Left Endwall (psf) = 2.0
- Right Endwall (psf) = 2.0
- Front Sidewall (psf) = 2.0
- Back Sidewall (psf) = 2.0
- Roof Live Load (psf) = 20.0
- Frame Live Load (psf) = 12.0
- Collateral Load (psf) = 0.5
- Snow Load (psf) = 3.1
- Minimum Snow (psf) = 4.0
- Wind Speed (mph) = 120.0
- Wind Code = FBC 23 (8TH EDITION)
- Exposure = B
- Closure = Enclosed
- Internal Wind Coeff = -0.18, +0.18
- Risk Category = II - Normal
- Importance - Wind = 1.00
- Importance - Seismic = 1.00
- Seismic Design Category = B
- Seismic Coeff (Sms) = 0.17

ISSUE	DET	CHK	DATE
UNION LoSTEEL			
CUSTOMER: TRAFICANTE			
JOB NO: 8728	DATE: 8/14/24		
LOCATION: LAKE CITY, FL 32025			
DRAWING NAME: ANCHOR BOLT REACTIONS			
DRAWING NO: PAGE 1.2 A	DRAWN BY: PS	CHECKED BY: SPW	SCALE: NONE

FRAME LINES: 1

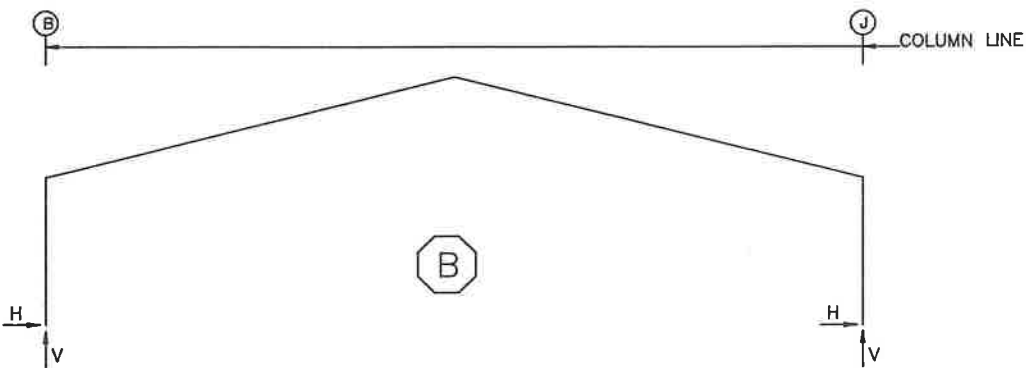

RIGID FRAME: BASIC COLUMN REACTIONS (k)

Frame Line	Column Line	Dead Horz	Dead Vert	Collateral Horz	Collateral Vert	Live Horz	Live Vert	Snow Horz	Snow Vert	Snow_Drift Horz	Snow_Drift Vert	Wind_Left1 Horz	Wind_Left1 Vert
1	B	0.5	0.8	0.1	0.1	2.1	3.0	0.4	0.5	0.1	0.1	-2.2	-2.4
1	J	-0.5	0.8	-0.1	0.1	-2.1	3.0	-0.4	0.5	-0.1	0.1	0.9	-2.1
Frame Line	Column Line	Wind_Right1 Horz	Wind_Right1 Vert	Wind_Left2 Horz	Wind_Left2 Vert	Wind_Right2 Horz	Wind_Right2 Vert	Wind_Long1 Horz	Wind_Long1 Vert	Wind_Long2 Horz	Wind_Long2 Vert	Seismic_Left Horz	Seismic_Left Vert
1	B	-0.9	-2.1	-1.7	-1.1	-0.4	-0.7	-2.4	-4.3	0.4	0.1	0.0	0.0
1	J	2.2	-2.4	0.4	-0.7	1.7	-1.1	2.4	-4.3	-0.4	0.1	-0.1	0.0
Frame Line	Column Line	Seismic_Right Horz	Seismic_Right Vert	Wind_Left3 Horz	Wind_Left3 Vert	Wind_Right3 Horz	Wind_Right3 Vert	Wind_Left4 Horz	Wind_Left4 Vert	Wind_Right4 Horz	Wind_Right4 Vert	MIN_SNOW Horz	MIN_SNOW Vert
1	B	0.0	0.0	-1.7	-1.3	-0.3	-1.6	-1.1	0.1	0.3	-0.3	0.5	0.7
1	J	0.1	0.0	0.3	-1.6	1.7	-1.3	-0.3	-0.3	1.1	0.1	-0.5	0.7
Frame Line	Column Line	F1UNB_SL_L Horz	F1UNB_SL_L Vert	F1UNB_SL_R Horz	F1UNB_SL_R Vert								
1	B	0.3	0.5	0.3	0.3								
1	J	-0.3	0.3	-0.3	0.5								

RIGID FRAME: ANCHOR BOLTS & BASE PLATES

Frm Line	Col Line	Anc_Bolt Qty	Anc_Dia	Base_Plate Width	Base_Plate Length	Base_Plate Thick	Grout (in)
1	B	4	0.750	6.000	8.000	0.375	0.0
1	J	4	0.750	6.000	8.000	0.375	0.0

ENDWALL COLUMN: ANCHOR BOLTS & BASE PLATES

Frm Line	Col Line	Anc_Bolt Qty	Anc_Dia	Base_Plate Width	Base_Plate Length	Base_Plate Thick	Grout (in)
1	D	4	0.750	8.000	8.000	0.250	0.0
1	F	4	0.750	8.000	8.000	0.250	0.0

ANCHOR BOLT SUMMARY

Qty	Locate	Dia (in)	Type	Projection (in)
⊕ 8	Endwall	3/4"	GR36	1.50
⊕ 8	Frame	3/4"	GR36	2.50

GENERAL NOTES

- FOUNDATION DESIGN AND CONSTRUCTION ARE NOT THE RESPONSIBILITY OF METAL BUILDING MANUFACTURER.
- ALL REACTIONS ARE UNFACTORED.
- ULTIMATE WIND LOADS ARE USED TO DERIVE THE WIND REACTION.
- ANCHOR BOLTS SHALL BE ACCURATELY SET TO A TOLLERANCE OF +/- 1/8" IN BOTH ELEVATION AND LOCATION.
- COLUMN BASE PLATES ARE DESIGNED NOT TO EXCEED A BEARING PRESSURE OF 1050 POUNDS PER SQUARE INCH.

BUILDING BRACING REACTIONS

Wall Loc	Col Line	± Reactions(k)	Panel_Shear (lb/ft)	Note		
Line	Line	Wind Horz	Seismic Vert	Wind	Seis	
L_EW	1			440	10	(h)
F_SW	J			0	0	
R_EW	2	Bracing Not Used		0	0	
B_SW	B			440	10	

(h) Rigid frame at endwall

Reactions for seismic represent shear force, Eh
Reaction values shown are unfactored

ENDWALL COLUMN: BASIC COLUMN REACTIONS (k)

Frm Line	Col Line	Dead Vert	Wind Press Horz	Wind Suct Horz	Seis Long Vert
1	D	0.0	-2.0	2.1	0.0
1	F	0.0	-2.0	2.1	0.0

NOTES FOR REACTIONS

Building reactions are based on the following building data:

- Width (ft) = 55.0
- Length (ft) = 12.0
- Eave Height (ft) = 10.0 / 10.0
- Roof Slope (rise/12) = 3.00 / 3.00
- Roof Dead Load (psf) = 2.0
- Wall Dead Load (psf) = 2.0
- Left Endwall (psf) = 2.0
- Right Endwall (psf) = 2.0
- Front Sidewall (psf) = 2.0
- Back Sidewall (psf) = 2.0
- Roof Live Load (psf) = 20.0
- Frame Live Load (psf) = 17.4
- Collateral Load (psf) = 0.5
- Snow Load (psf) = 3.1
- Minimum Snow (psf) = 4.0
- Wind Speed (mph) = 120.0
- Wind Code = FBC 23 (8TH EDITION)
- Exposure = B
- Closure = Enclosed
- Internal Wind Coeff = -0.18, +0.18
- Risk Category = II - Normal
- Importance - Wind = 1.00
- Importance - Seismic = 1.00
- Seismic Design Category = B
- Seismic Coeff (Sms) = 0.17

NOTE: THE FRAMING AT BOTH ENDWALLS IS NOT DESIGNED TO ACCOMMODATE FUTURE ADDITIONS. REACTIONS CORRESPONDING TO THESE FRAME LINES REFLECT LOADINGS FOR ACTUAL TRIBUTARY AREA AND ARE NOT INTENDED TO INCLUDE ANY FUTURE MODIFICATIONS UNLESS NOTED OTHERWISE.

ISSUE	DET	CHK	DATE
UNION LoSTEEL			
CUSTOMER: TRAFICANTE			
JOB NO: 8728	DATE: 8/14/24		
LOCATION: LAKE CITY, FL 32025			
DRAWING NAME: ANCHOR BOLT REACTIONS			
DRAWING NO: PAGE 1.2 B	DRAWN BY: PS	CHECKED BY: SPW	SCALE: NONE

EXTENSION/CANOPY BOLTS				
ROOF PLAN				
MARK	QUAN	TYPE	DIA	LENGTH
EB-2	4	A325	5/8"	2"
EB-3	4	A325	5/8"	2"
EB-4	4	A325	5/8"	2"

MEMBER TABLE		
ROOF PLAN		
MARK	PART	LENGTH
8728-A		
EB-1	10X2CH16	9'-3 15/16"
EB-2	W10X12	5'-7 1/2"
EB-3	W10X12	5'-7 1/2"
EB-4	W10X12	5'-4 9/16"
P-1	10x25Z14	27'-11 1/2"
P-2	10x25Z16	28'-11 1/2"
P-3	10x25Z16	27'-11 1/2"
P-4	10x25Z16	23'-11 1/2"
P-5	10x25Z16	24'-3 1/2"
P-6	10x25Z16	23'-3 1/2"
P-7	10x25Z16	7 1/2"
E-1	10LE14@3	23'-11 1/2"
E-2	10LE14@3	24'-3 1/2"
E-3	10LE14@3	23'-3 1/2"
E-4	10LE14@3	24'-11 1/2"
E-5	10x35C14	24'-11 1/2"
E-6	10LE14@3	7 1/2"
CB-3	1/4 CBL	33'-1"
CB-4	1/4 CBL	30'-1"
CB-5	1/4 CBL	32'-9"
CB-6	1/4 CBL	30'-4"
8728-B		
P-100	8x25Z16	11'-11 1/2"
E-100	8LE14@3	11'-11 1/2"
CB-100	1/4 CBL	18'-6"
CB-101	1/4 CBL	17'-1"

CONNECTION PLATES	
ROOF PLAN	
MARK/PART	TYPE
1	FBX1

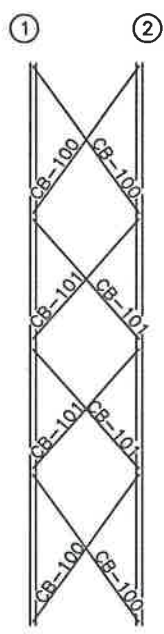
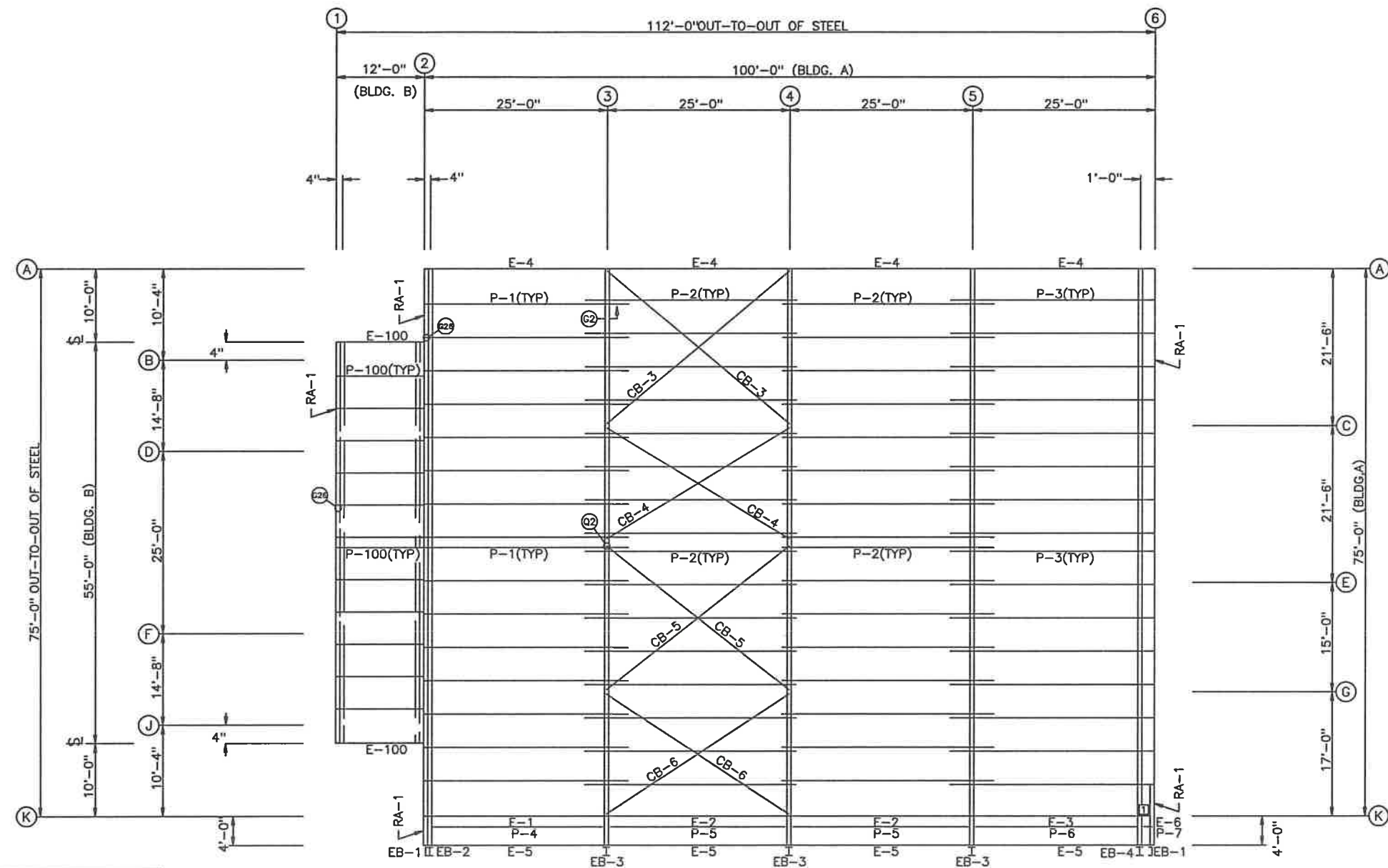

NOTE: CABLES SEPARATED FOR CLARITY!

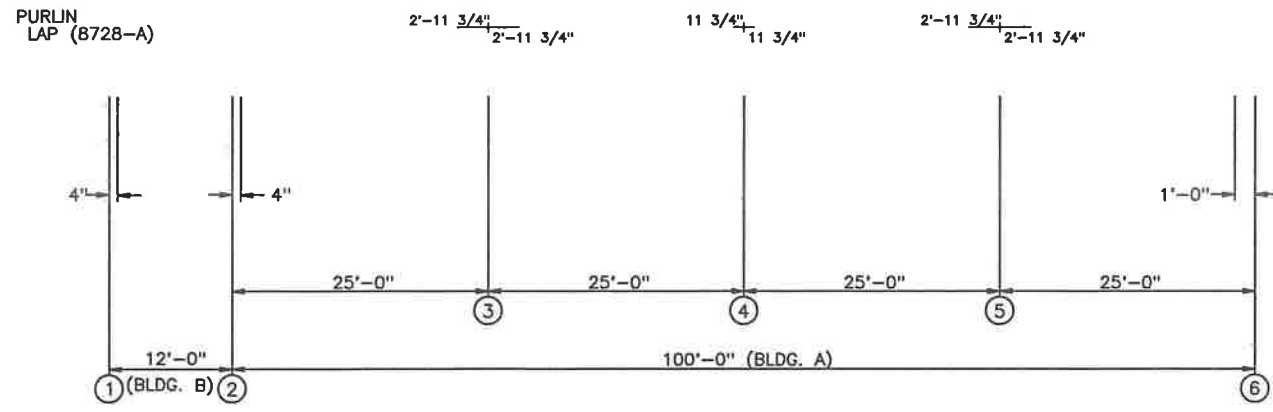

ROOF FRAMING PLAN

ISSUE	DET	CHK	DATE
UNION LaSTEEL			
CUSTOMER: TRAFICANTE			
JOB NO: 8728	DATE: 8/14/24		
LOCATION: LAKE CITY, FL 32025			
DRAWING NAME: ROOF FRAMING LAYOUT			
DRAWING NO: PAGE 2	DRAWN BY: PS	CHECKED BY: SPW	SCALE: NONE

SPLICE BOLT TABLE						
MARK	Qty	Top	Bot	Int	TYPE	DIA Length
SP-1	4	4	0		A325	5/8" 2"

BASE PLATE TABLE			
COL MARK	PLATE SIZE	Width	THICK Length
BP-1	6" x 3/8" x 8"		

MEMBER TABLE							
MARK	Weight	Web Depth Start/End	Web THICK	PLATE Length	Outside Flange W x Thk x Length	Inside Flange W x Thk x Length	
RF1-100	137	7.5/ 7.5	0.135	8'-4 13/16"	5 x 1/4" x 9'-3 1/8"	5 x 1/4" x 8'-4 13/16"	
RF1-101	369	7.5/ 7.5	0.250	1'-0 1/4"	5 x 1/4" x 7 15/16"	5 x 1/4" x 20'-0"	
RF1-102	137	7.5/ 7.5	0.135	12'-9 5/8"	5 x 1/4" x 7'-6 11/16"	5 x 1/4" x 7'-6 11/16"	
		7.5/ 7.5	0.250	1'-0 1/4"	5 x 1/4" x 7 15/16"	5 x 1/4" x 8'-4 13/16"	
		7.5/ 7.5	0.135	8'-4 13/16"	5 x 1/4" x 9'-3 1/8"		

▽ FLANGE BRACES: (1) One Side; (2) Two Sides
 FBxxA(1): xx=length(in)
 A - L2x2x14

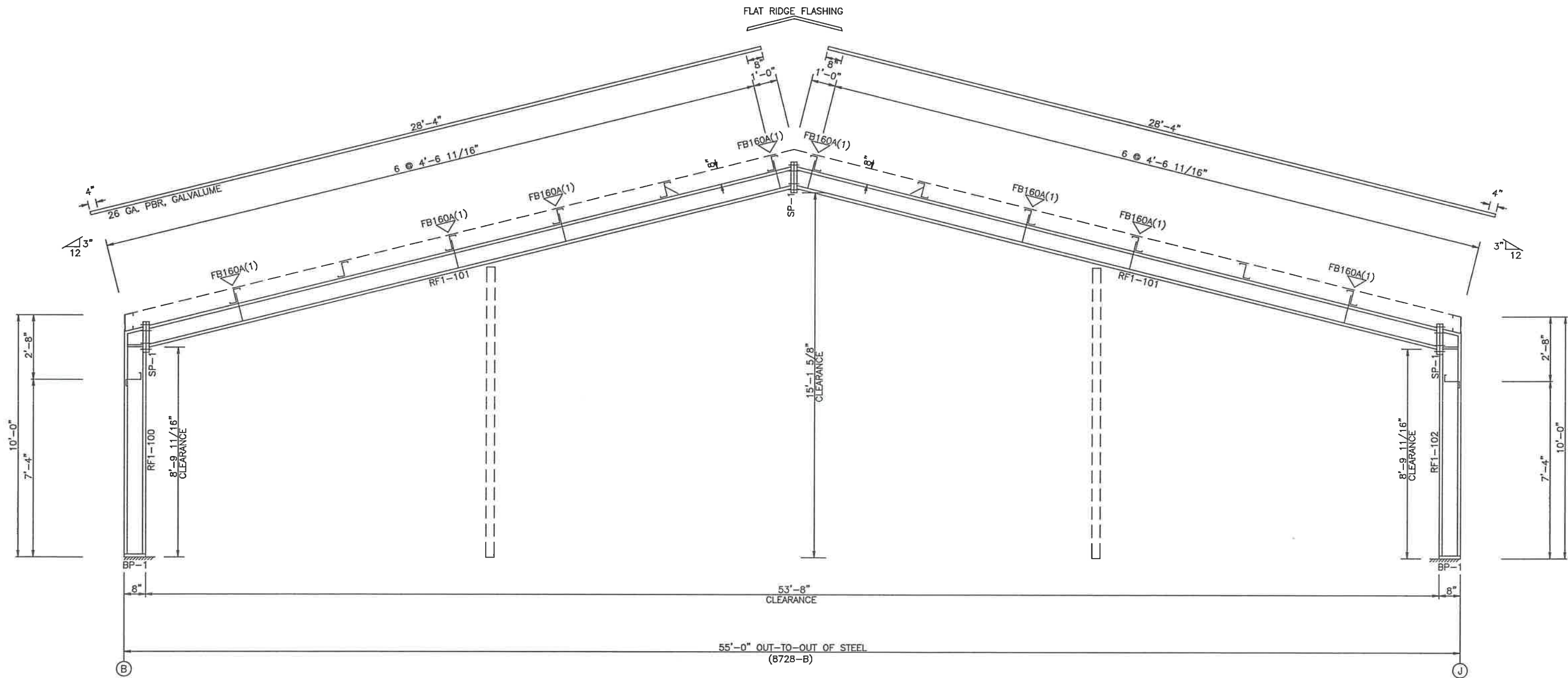

RIGID FRAME ELEVATION: FRAME LINE 1

NOTE: THE FRAMING AS DEPICTED ABOVE IS NOT DESIGNED TO ACCOMMODATE ANY FUTURE EXPANSION.

ISSUE	DET	CHK	DATE
UNION LoSTEEL			
CUSTOMER: TRAFICANTE			
JOB NO: 8728	DATE: 8/14/24		
LOCATION: LAKE CITY, FL 32025			
DRAWING NAME: RIGID FRAME CROSS SECTION			
DRAWING NO: PAGE 2.1	DRAWN BY: PS	CHECKED BY: SPW	SCALE: NONE

SPlice BOLT TABLE							
MARK	Qty	Top	Bot	Int	TYPE	DIA	Length
SP-1	4	4	0		A325	5/8"	2"

BASE PLATE TABLE			
COL MARK	PLATE SIZE	Width	THICK Length
BP-1	6"	1/2"	8"

FLANGE BRACES: (1) One Side; (2) Two Sides
 FBxxA(1): xx=length(in)
 A - L2x2x14

MEMBER TABLE						
MARK	Weight	Web Depth Start/End	Web THICK	PLATE Length	Flange	
					Outside W x Thk x Length	Inside W x Thk x Length
RF1-1	285	7.5/24.0	0.135	13'-7"	6 x 1/4" x 13'-0 15/16"	6 x 1/4" x 11'-2 11/16"
RF1-2	659	24.0/12.3 12.3/ 9.5 9.5/ 9.5 9.5/ 9.5	0.135 0.135 0.135 0.135	14'-11" 3'-7 9/16" 14'-11" 3'-5 7/8"	6 x 1/4" x 2'-0 15/16" 6 x 1/4" x 20'-0" 6 x 1/4" x 16'-5 3/8"	6 x 1/4" x 18'-7" 6 x 1/4" x 18'-2 7/16"
RF1-3	285	24.0/ 7.5	0.135	13'-7"	6 x 1/4" x 2'-0 15/16"	6 x 1/4" x 11'-2 11/16"
EB-2	69	W10X12			6 x 1/4" x 13'-0 15/16"	

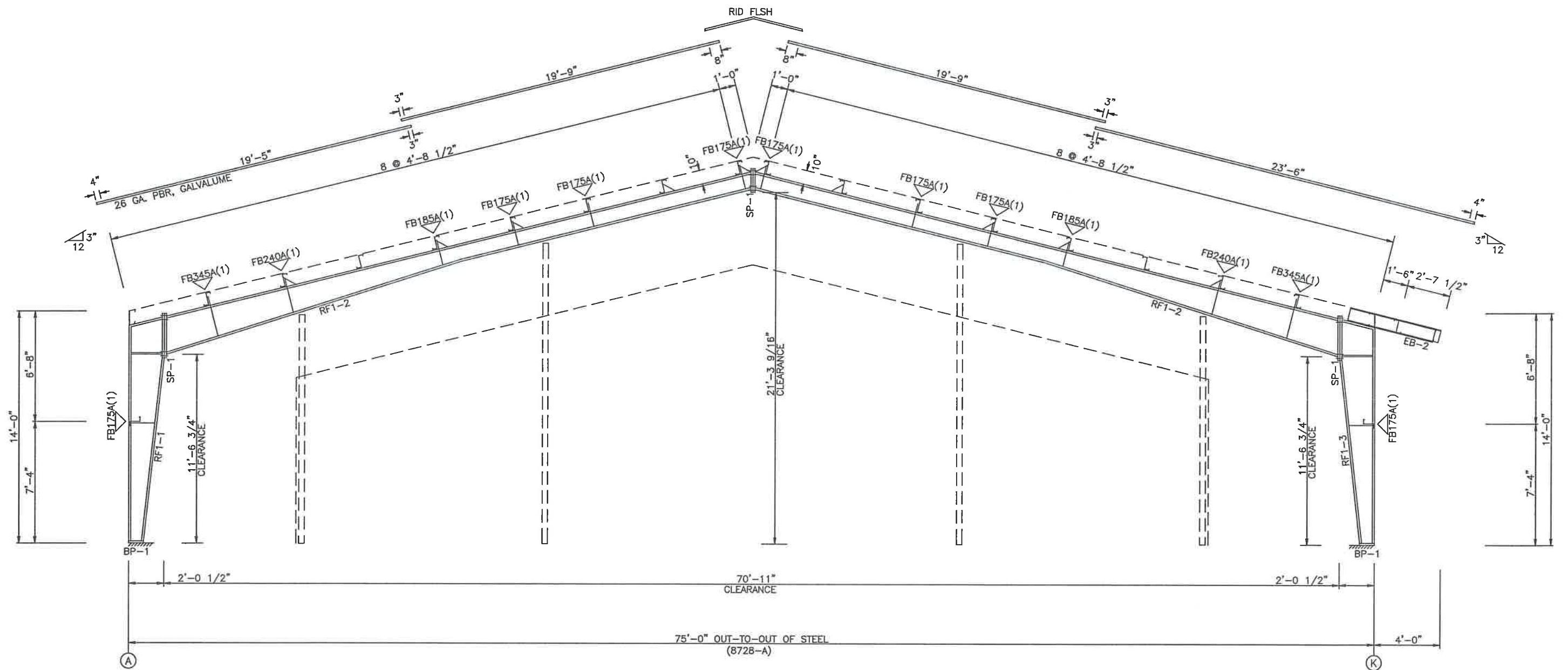

RIGID FRAME ELEVATION: FRAME LINE 2

ISSUE	DET	CHK	DATE
UNION LaSTEEL			
CUSTOMER: TRAFICANTE			
JOB NO: 8728	DATE: 8/14/24		
LOCATION: LAKE CITY, FL 32025			
DRAWING NAME: RIGID FRAME CROSS SECTION			
DRAWING NO: PAGE 2.2	DRAWN BY: PS	CHECKED BY: SPW	SCALE: NONE

SPLICE BOLT TABLE						
MARK	Qty		TYPE	DIA	Length	
	Top	Bot			Int	
SP-1	4	4	0	A325	3/4"	2 1/2"
SP-2	4	4	0	A325	5/8"	2"

BASE PLATE TABLE			
COL MARK	PLATE SIZE		
	Width	THICK	Length
BP-1	6"	1/2"	8 1/2"

FLANGE BRACES: (1) One Side; (2) Two Sides
 FBxxA(1): xx=length(in)
 A - L2x2x14

MEMBER TABLE									
MARK	Weight	Web		Web PLATE		Outside Flange		Inside Flange	
		Start/End	THICK	Length	Length	W x Thk x Length	W x Thk x Length	W x Thk x Length	
RF2-1	320	7.5/24.0	0.135	11'-1 3/4"		6 x 1/4" x 13'-0 15/16"	6 x 5/16" x 11'-2 3/4"		
RF2-2	686	24.0/24.0	0.188	2'-5 1/4"		6 x 1/4" x 2'-0 15/16"			
		24.0/12.3	0.135	14'-11"		6 x 1/4" x 20'-0"			
		12.3/9.5	0.135	3'-7 1/4"		6 x 1/4" x 16'-5 1/8"	6 x 5/16" x 18'-6 3/4"	6 x 1/4" x 18'-2 7/16"	
RF2-3	686	9.5/9.5	0.135	14'-11"					
		9.5/9.5	0.135	3'-5 7/8"		6 x 1/4" x 16'-5 1/8"	6 x 1/4" x 18'-2 7/16"		
		9.5/9.5	0.135	3'-5 7/8"		6 x 1/4" x 20'-0"	6 x 5/16" x 18'-6 3/4"		
		9.5/12.3	0.135	3'-7 1/4"					
RF2-4	323	24.0/24.0	0.188	2'-5 1/4"		6 x 1/4" x 2'-0 15/16"			
		24.0/7.5	0.135	11'-1 3/4"		6 x 1/4" x 13'-0 15/16"	6 x 5/16" x 11'-2 3/4"		
		W10X12							
EB-3	74								

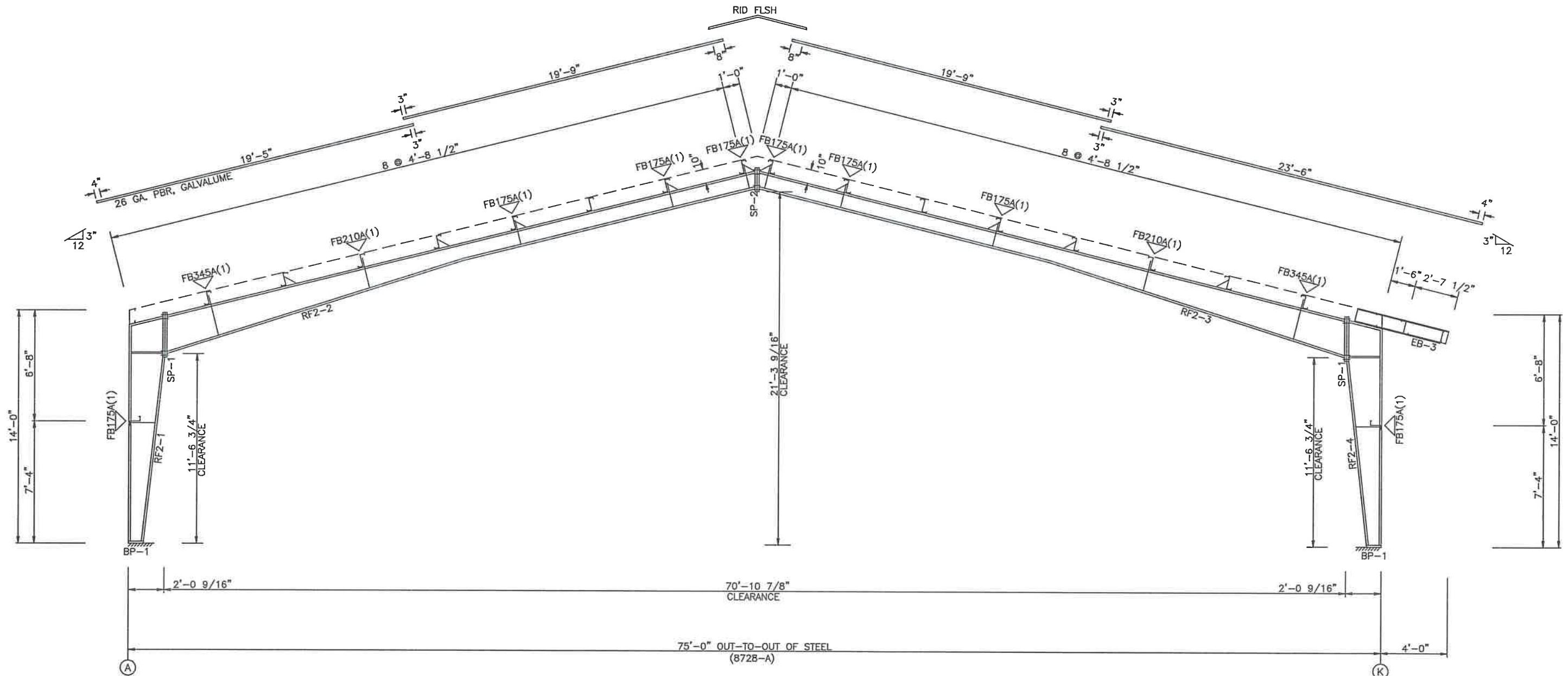

RIGID FRAME ELEVATION: FRAME LINE 3 4 5

ISSUE	DET	CHK	DATE
UNION LaSTEEL			
CUSTOMER: TRAFICANTE			
JOB NO: 8728	DATE: 8/14/24		
LOCATION: LAKE CITY, FL 32025			
DRAWING NAME: RIGID FRAME CROSS SECTION			
DRAWING NO: PAGE 2.3	DRAWN BY: PS	CHECKED BY: SPW	SCALE: NONE

SPLICE BOLT TABLE							
MARK	Qty	Top	Bot	Int	TYPE	DIA	Length
SP-1	4	4	0		A325	5/8"	2"

BASE PLATE TABLE				
COL MARK	PLATE SIZE	Width	THICK	Length
BP-1	6" x 3/8" x 8"			

FLANGE BRACES: (1) One Side; (2) Two Sides
 FBxxA(1): xx=length(in)
 A - L2x2x14

MEMBER TABLE							
MARK	Weight	Web		Web PLATE THICK	Web Length	Outside Flange W x Thk x Length	Inside Flange W x Thk x Length
		Start	End				
RF3-1	273	7.5	20.0	0.135	13'-6 1/8"	6 x 1/4" x 13'-1 1/16"	6 x 1/4" x 11'-5 1/2"
RF3-2	669	20.0	12.1	0.135	14'-11"	6 x 1/4" x 1'-8 13/16"	6 x 1/4" x 18'-9 7/8"
		12.1	10.0	0.135	3'-10 11/16"	6 x 1/4" x 20'-0"	6 x 1/4" x 18'-1 3/8"
		10.0	13.3	0.135	14'-11"		
		13.3	14.0	0.135	3'-5 7/8"	6 x 1/4" x 16'-9 1/2"	6 x 1/4" x 18'-1 3/8"
RF3-3	671	14.0	13.3	0.135	3'-5 7/8"	6 x 1/4" x 16'-9 1/2"	6 x 1/4" x 18'-1 3/8"
		13.3	10.0	0.135	14'-11"	6 x 1/4" x 20'-0"	6 x 1/4" x 18'-9 7/8"
		10.0	12.1	0.135	3'-10 11/16"		
		12.1	20.0	0.135	14'-11"		
RF3-4	273	20.0	7.5	0.135	13'-6 1/8"	6 x 1/4" x 1'-8 13/16"	6 x 1/4" x 11'-5 1/2"
EB-4	69	W10X12					

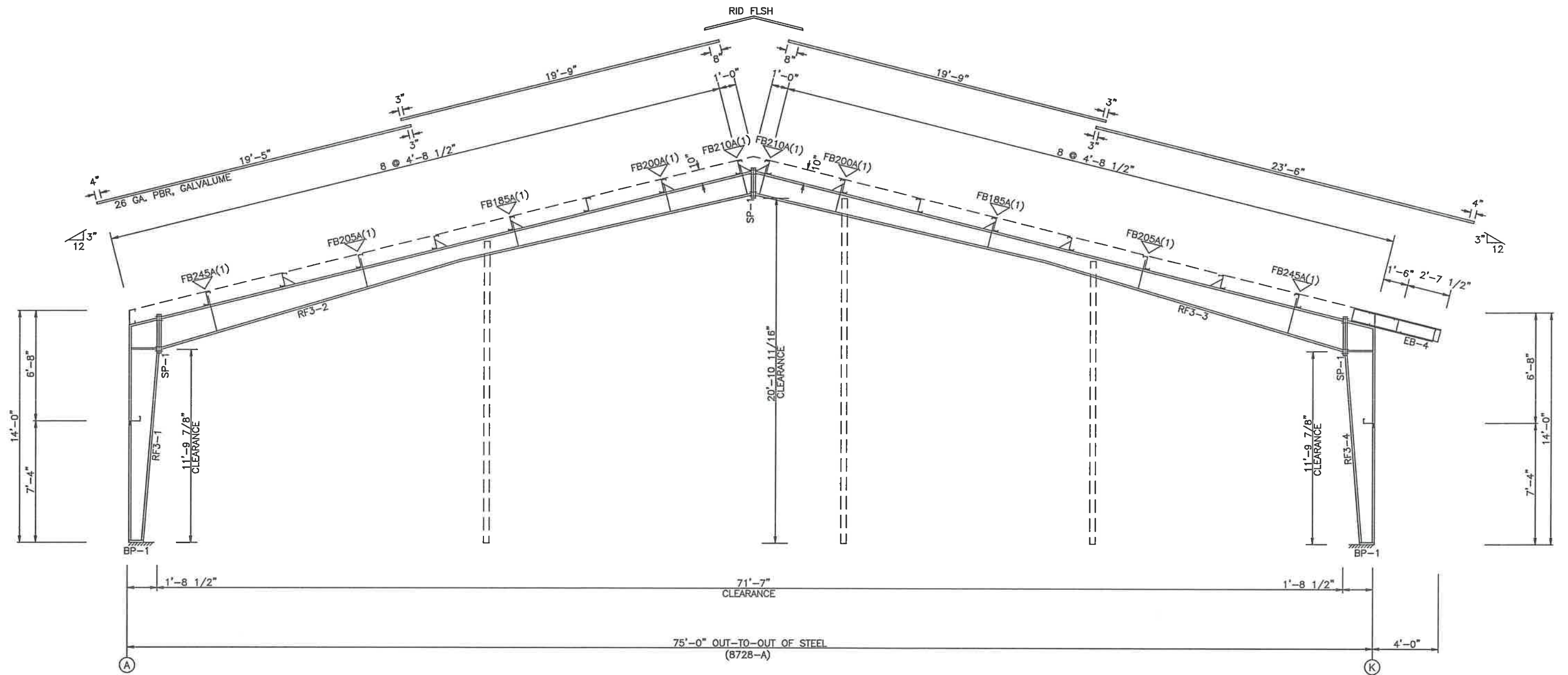

RIGID FRAME ELEVATION: FRAME LINE 6

NOTE: THE FRAMING AS DEPICTED ABOVE IS NOT DESIGNED TO ACCOMMODATE ANY FUTURE EXPANSION.

ISSUE	DET	CHK	DATE
UNION LaSTEEL			
CUSTOMER: TRAFICANTE			
JOB NO: 8728	DATE: 8/14/24		
LOCATION: LAKE CITY, FL 32025			
DRAWING NAME: RIGID FRAME CROSS SECTION			
DRAWING NO: PAGE 2.4	DRAWN BY: PS	CHECKED BY: SPW	SCALE: NONE

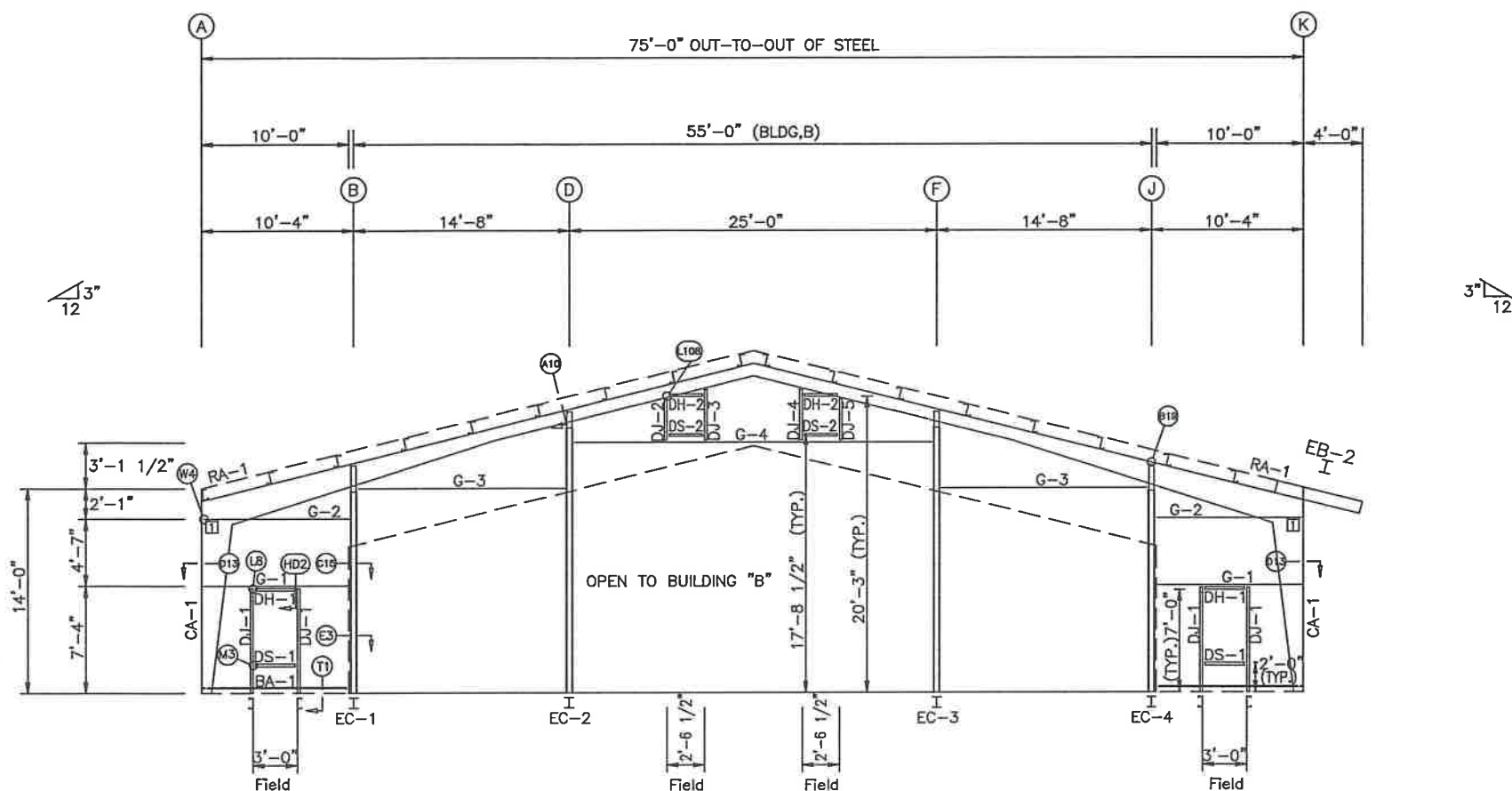

ENDWALL FRAMING: FRAME LINE 2

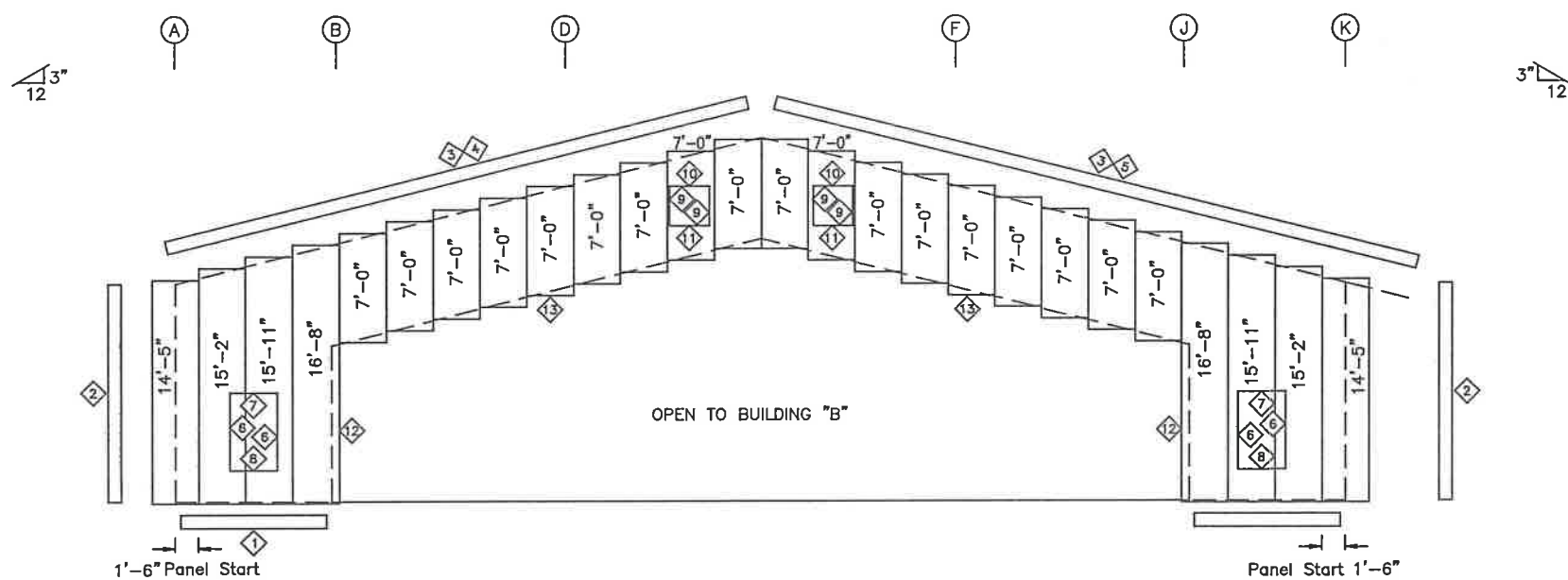

ENDWALL SHEETING & TRIM: FRAME LINE 2
PANELS: 26 Ga. R - NEED COLOR

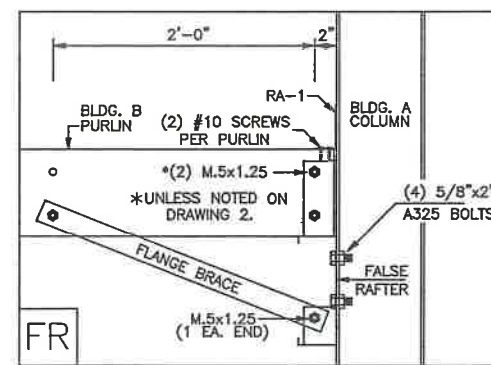
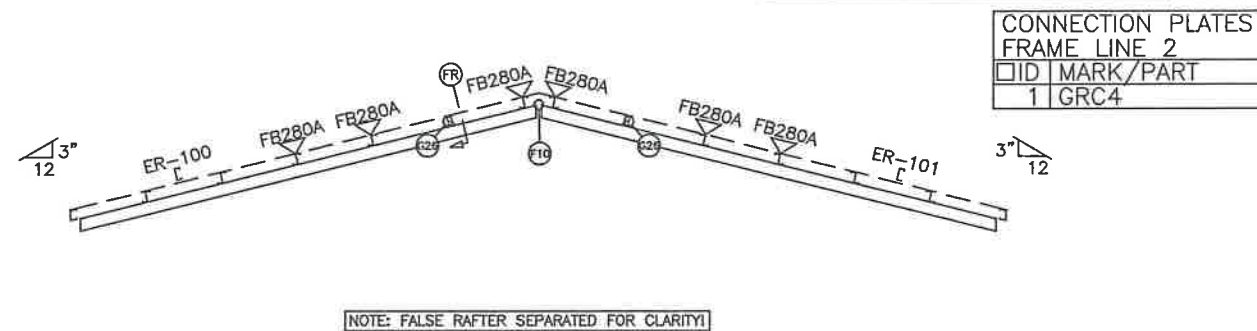
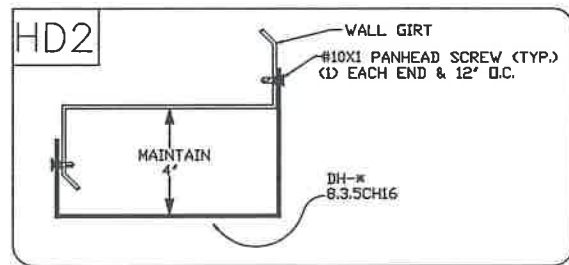

BOLT TABLE				
FRAME LINE 2				
LOCATION	QUAN	TYPE	DIA	LENGTH
Columns/Raf	2	A325	5/8"	2"
Jamb/Raf	2	A325	5/8"	2"
ER-*/EC-*	4	A325	5/8"	2"
ER-100/ER101	8	A325	5/8"	2"

TRIM TABLE			
FRAME LINE 2			
ID	PART	LENGTH	DETAIL
1	BASE TRM	10'-3"	TRIM_16
2	O/S CORN	14'-2"	TRIM_5
3	RAKE TRM	20'-3"	
4	RAKE TRM	18'-8"	
5	RAKE TRM	2'-10"	
6	R JAMB	5'-3"	TRIM_8
7	R HEAD	3'-3"	TRIM_61
8	R HEAD	3'-3"	TRIM_7
9	R JAMB	2'-10"	TRIM_8
10	R HEAD	2'-10"	TRIM_61
11	R HEAD	2'-10"	TRIM_7
12	4.5X4.5 1/S	10'-3"	X2
13	RTRANS	14'-9"	X1

MEMBER TABLE		
FRAME LINE 2		
MARK	PART	LENGTH
EC-1	B08541	14'-0 3/8"
EC-2	B08541	18'-4 3/8"
EC-3	B08541	18'-4 3/8"
EC-4	B08541	14'-0 3/8"
DJ-1	8X25C16	7'-4"
DJ-2	8X25C16	2'-10 3/4"
DJ-3	8X25C16	3'-6 3/8"
DJ-4	8X25C16	3'-6 7/16"
DJ-5	8X25C16	2'-10 13/16"
DH-1	8.3.5CH6	3'-0"
DH-2	8X25C16	2'-6 1/2"
DS-1	8X25C16	3'-0"
DS-2	8X25C16	2'-6 1/2"
ER-100	8X35C14	28'-3 7/8"
ER-101	8X35C14	28'-3 7/8"
G-1	8x25Z16	8'-4 11/16"
G-2	8x25Z16	6'-5"
G-3	8x25Z16	13'-11 1/2"
G-4	8x25Z16	24'-3 1/2"

CONNECTION PLATES	
FRAME LINE 2	
ID	MARK/PART
1	GRC4

ISSUE	DET	CHK	DATE
UNION LoSTEEL			
CUSTOMER: TRAFICANTE			
JOB NO: 8728	DATE: 8/14/24		
LOCATION: LAKE CITY, FL 32025			
DRAWING NAME: FRAMING & SHEETING LAYOUT			
DRAWING NO: PAGE 3	DRAWN BY: PS	CHECKED BY: SPW	SCALE: NONE

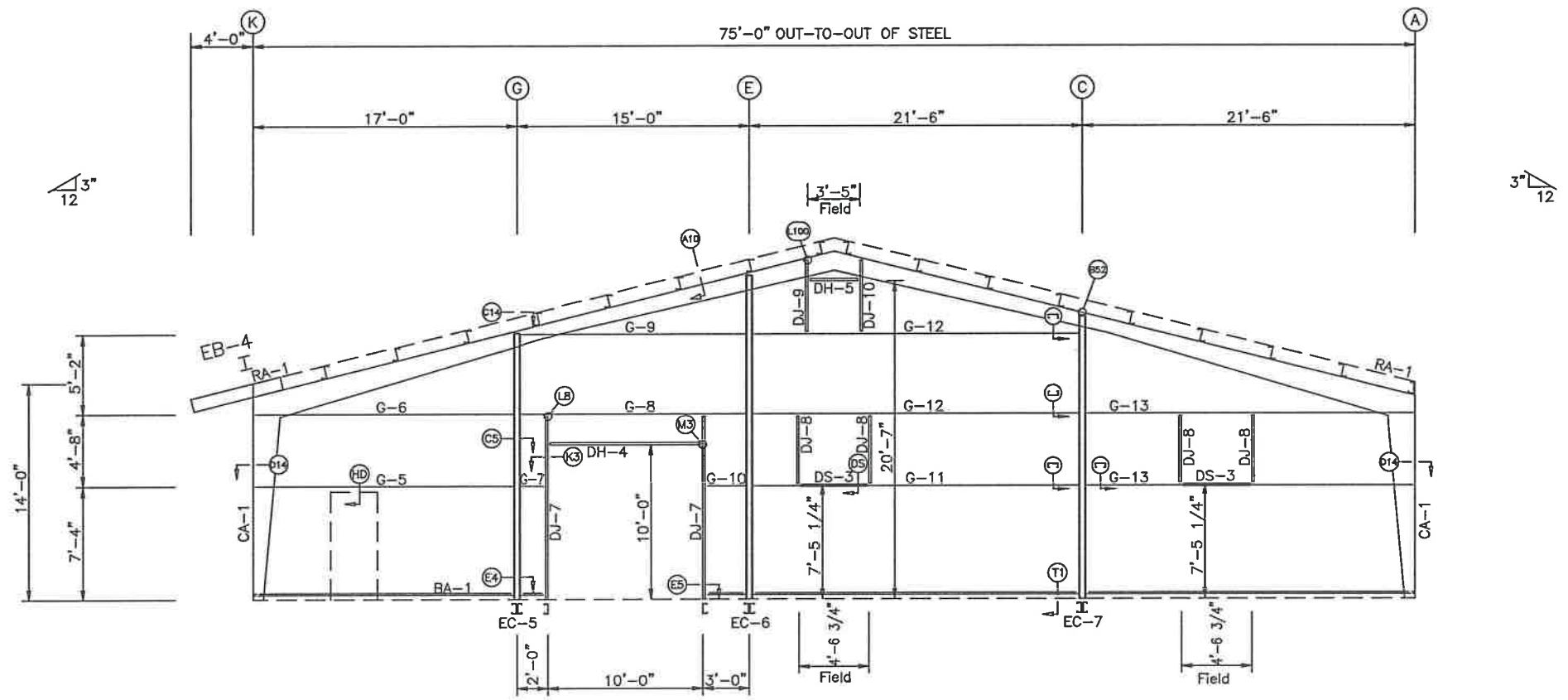

ENDWALL FRAMING: FRAME LINE 6

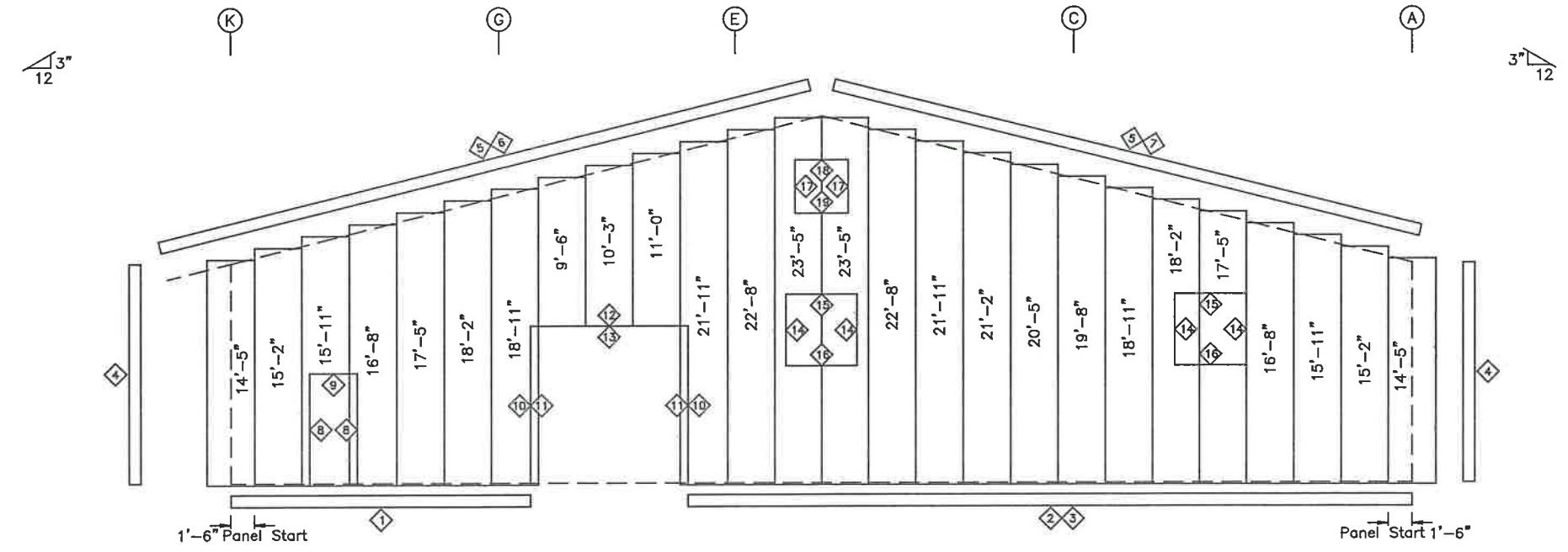

ENDWALL SHEETING & TRIM: FRAME LINE 6
PANELS: 26 Ga. R - NEED COLOR

NOTE: THE FRAMING AS DEPICTED ABOVE IS NOT DESIGNED TO ACCOMMODATE ANY FUTURE EXPANSION.

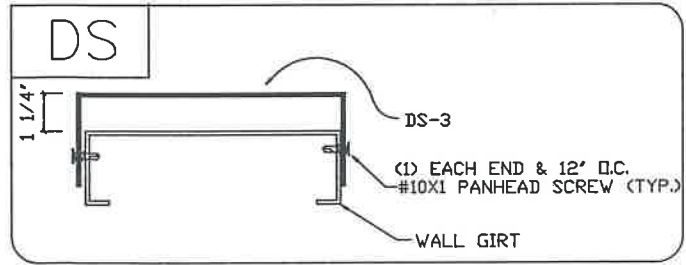

BOLT TABLE FRAME LINE 6				
LOCATION	QUAN	TYPE	DIA	LENGTH
Columns/Raf	2	A325	5/8"	2"
Jamb	2	A325	5/8"	2"

TRIM TABLE FRAME LINE 6				
ID	PART	LENGTH	DETAIL	
1	BASE TRM	19'-3"	TRIM_16	
2	BASE TRM	20'-3"	TRIM_16	
3	BASE TRM	6'-3"	TRIM_16	
4	O/S CORN	14'-2"	TRIM_5	
5	RAKE TRM	20'-3"		
6	RAKE TRM	2'-10"		
7	RAKE TRM	18'-8"		
8	R JAMB	7'-3"	TRIM_8	
9	R HEAD	3'-3"	TRIM_61	
10	CT8	10'-1"	TRIM_11	
11	R JAMB	10'-3"	TRIM_8	
12	CT8	10'-0"	TRIM_10	
13	R HEAD	10'-3"	TRIM_61	
14	R JAMB	4'-10"	TRIM_8	
15	R HEAD	4'-10"	TRIM_61	
16	R HEAD	4'-10"	TRIM_7	
17	R JAMB	3'-8"	TRIM_8	
18	R HEAD	3'-8"	TRIM_61	
19	R HEAD	3'-8"	TRIM_7	

MEMBER TABLE FRAME LINE 6		
MARK	PART	LENGTH
EC-5	8X7DC16	17'-3 1/8"
EC-6	8X7DC12	21'-0 1/8"
EC-7	8X8DC14	18'-4 5/8"
DJ-7	8X35C12	12'-0"
DJ-8	8X25C16	4'-8"
DJ-9	8X25C16	4'-9 1/2"
DJ-10	8X25C16	4'-9 1/2"
DH-4	8X35C12	10'-0"
DH-5	8X25C16	3'-5"
DS-3	8X2CH16	4'-6 3/4"
G-5	8x25Z16	16'-7 1/2"
G-6	8x25C16	16'-7 1/2"
G-7	8x25Z16	1'-3 1/2"
G-8	8x25C16	14'-3 1/2"
G-9	8x25Z16	14'-3 1/2"
G-10	8x25Z16	2'-3 1/2"
G-11	8x35C14	20'-9 1/2"
G-12	8x25C14	20'-9 1/2"
G-13	8x40C14	21'-1 1/2"

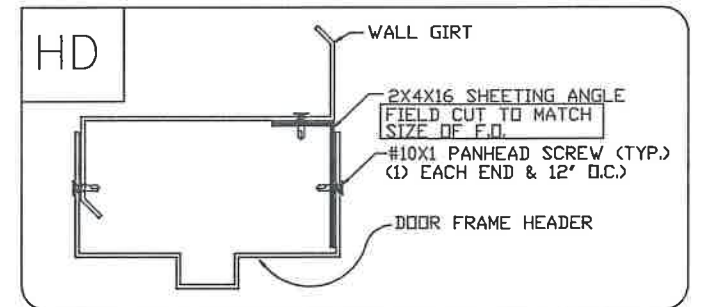

ISSUE	DET	CHK	DATE

UNION LaSTEEL

CUSTOMER: TRAFICANTE

JOB NO: 8728 DATE: 8/14/24

LOCATION: LAKE CITY, FL 32025

DRAWING NAME: FRAMING & SHEETING LAYOUT

DRAWING NO: PAGE 3.1 DRAWN BY: PS CHECKED BY: SPW SCALE: NONE

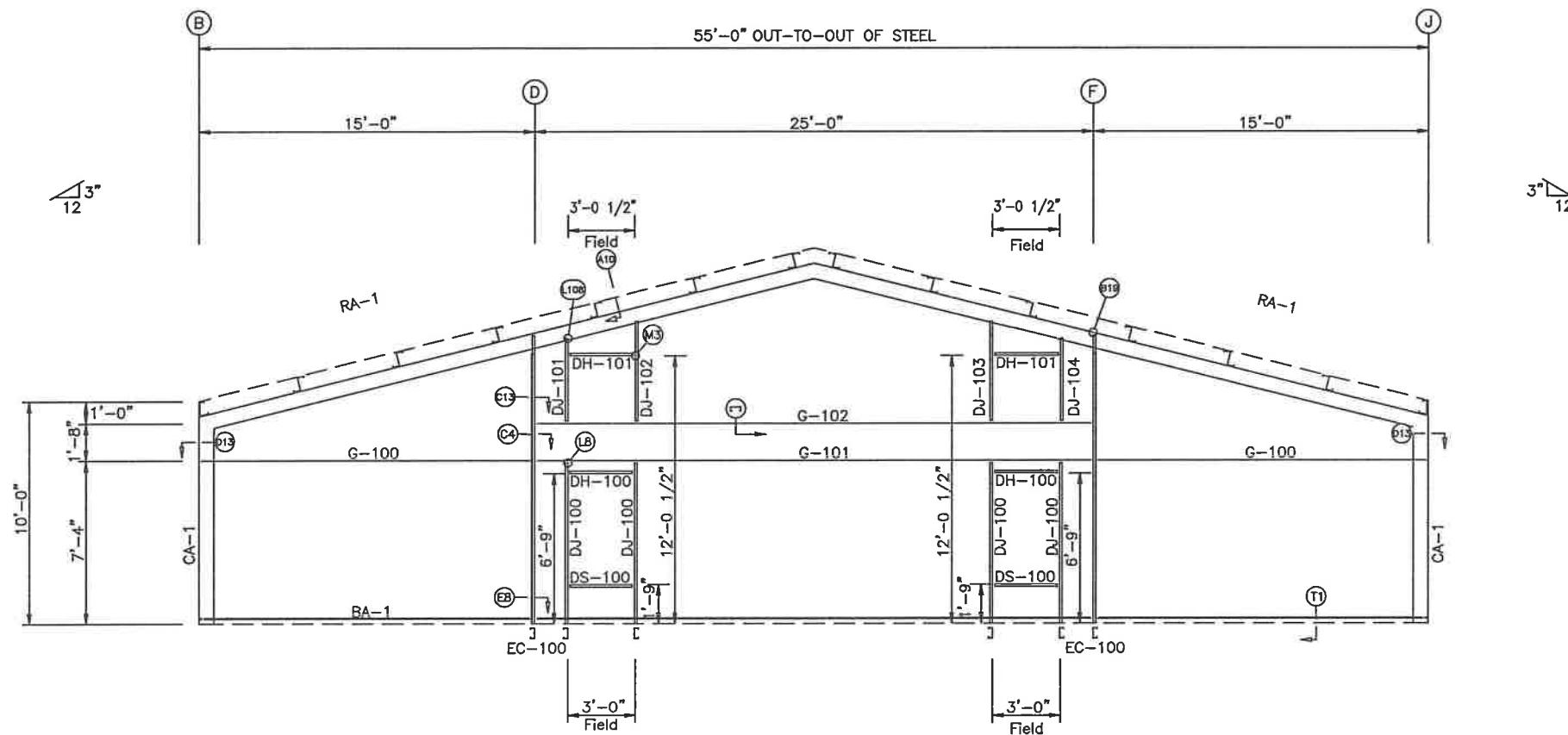

ENDWALL FRAMING: FRAME LINE 1

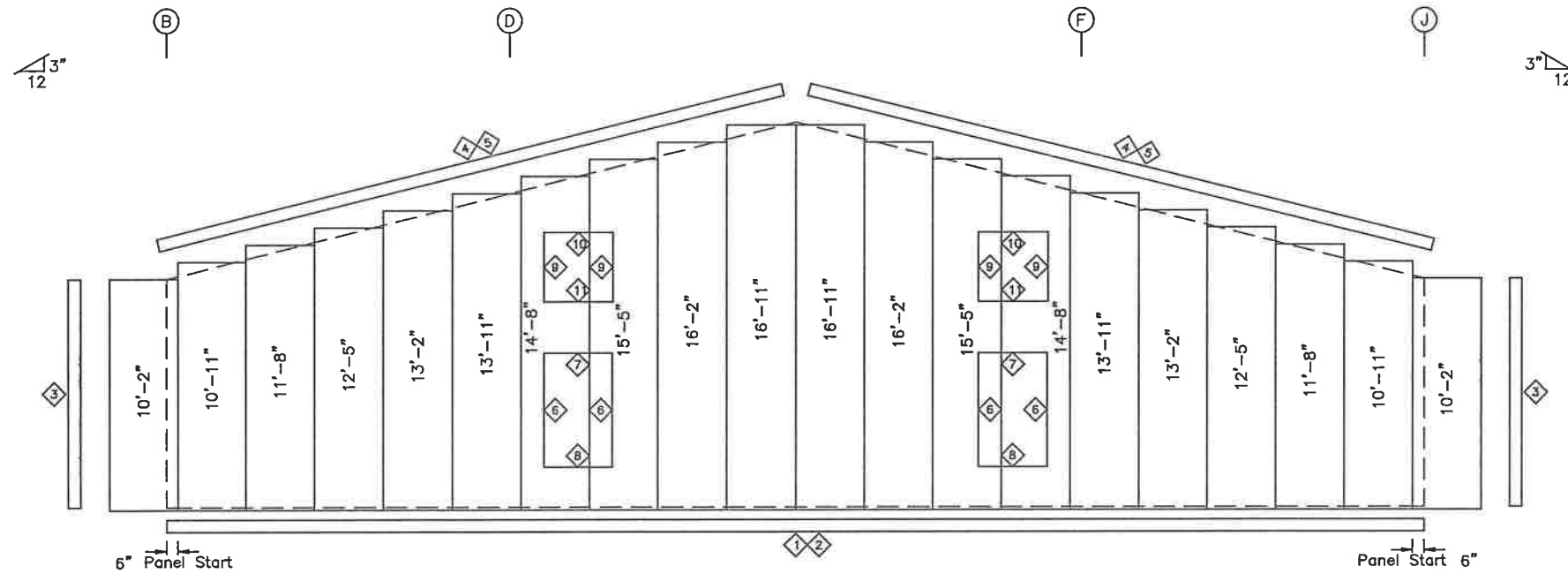

ENDWALL SHEETING & TRIM: FRAME LINE 1
PANELS: 26 Ga. R - NEED COLOR

NOTE: THE FRAMING AS DEPICTED ABOVE IS NOT DESIGNED TO ACCOMMODATE ANY FUTURE EXPANSION.

BOLT TABLE				
FRAME LINE 1				
LOCATION	QUAN	TYPE	DIA	LENGTH
Columns/Raf	2	A325	5/8"	2"
Jamb	2	A325	5/8"	2"

TRIM TABLE			
FRAME LINE 1			
ID	PART	LENGTH	DETAIL
1	BASE TRM	20'-3"	TRIM_16
2	BASE TRM	15'-3"	TRIM_16
3	O/S CORN	10'-2"	TRIM_5
4	RAKE TRM	20'-3"	
5	RAKE TRM	8'-5"	
6	R JAMB	5'-3"	TRIM_8
7	R HEAD	3'-3"	TRIM_61
8	R HEAD	3'-3"	TRIM_7
9	R JAMB	3'-4"	TRIM_8
10	R HEAD	3'-4"	TRIM_61
11	R HEAD	3'-4"	TRIM_7

MEMBER TABLE		
FRAME LINE 1		
MARK	PART	LENGTH
EC-100	8X35C16	12'-2 1/2"
DJ-100	8X25C16	7'-4"
DJ-101	8X25C16	3'-7"
DJ-102	8X25C16	4'-4 1/8"
DJ-103	8X25C16	4'-4"
DJ-104	8X25C16	3'-6 7/8"
DH-100	8.3.5CH6	3'-0"
DH-101	8.3.5CH6	3'-0 1/2"
DS-100	8.3.5CH6	3'-0"
G-100	8x25Z16	13'-11 1/2"
G-101	8x25Z14	24'-11 1/2"
G-102	8x25C14	24'-11 1/2"

ISSUE	DET	CHK	DATE
UNION LoSTEEL			
CUSTOMER: TRAFICANTE			
JOB NO: 8728	DATE: 8/14/24		
LOCATION: LAKE CITY, FL 32025			
DRAWING NAME: FRAMING & SHEETING LAYOUT			
DRAWING NO: PAGE 3.2	DRAWN BY: PS	CHECKED BY: SPW	SCALE: NONE

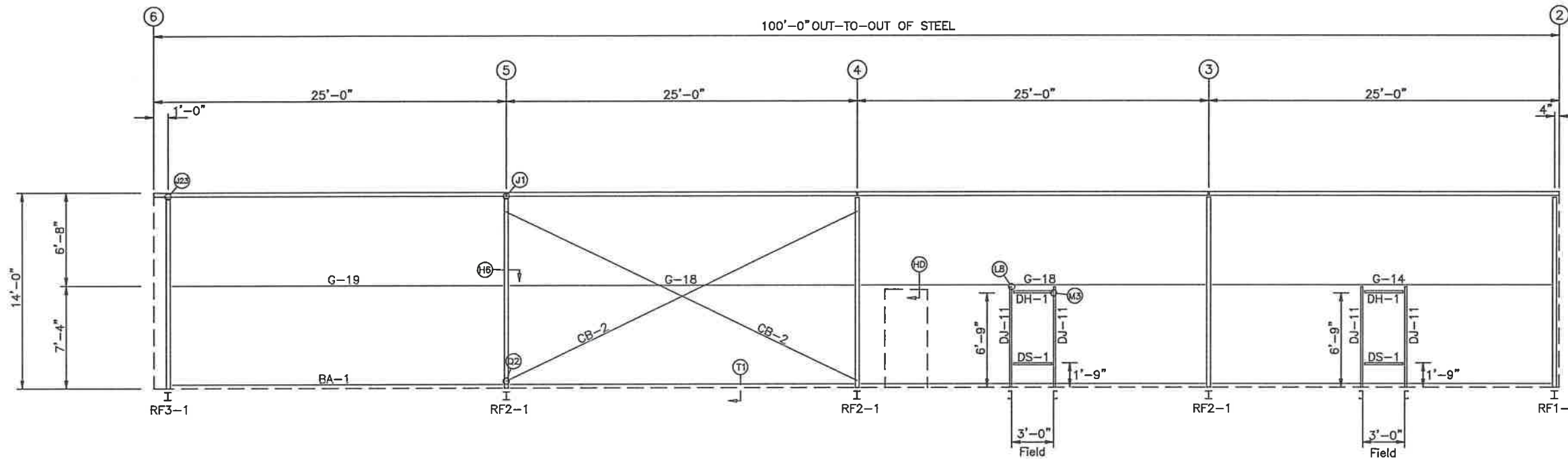

SIDEWALL FRAMING: FRAME LINE A

TRIM TABLE FRAME LINE A			
ID	PART	LENGTH	DETAIL
1	BASE TRM	20'-3"	TRIM_16
2	O/S CORN	14'-2"	TRIM_5
3	GUTTER	20'-3"	TRIM_1
4	GUTEND L	1"	TRIM_2
5	GUTEND R	1"	TRIM_2
6	R JAMB	5'-3"	TRIM_8
7	R HEAD	3'-3"	TRIM_61
8	R HEAD	3'-3"	TRIM_7
9	R JAMB	7'-3"	TRIM_8

MEMBER TABLE FRAME LINE A		
MARK	PART	LENGTH
DJ-11	8X25C16	7'-4"
DH-1	8X25C16	3'-0"
DS-1	8X25C16	3'-0"
G-14	8x25Z12	23'-11 1/2"
G-18	8x25Z12	24'-3 1/2"
G-19	8x25Z12	23'-3 1/2"
CB-2	5/16 CBL	28'-6"

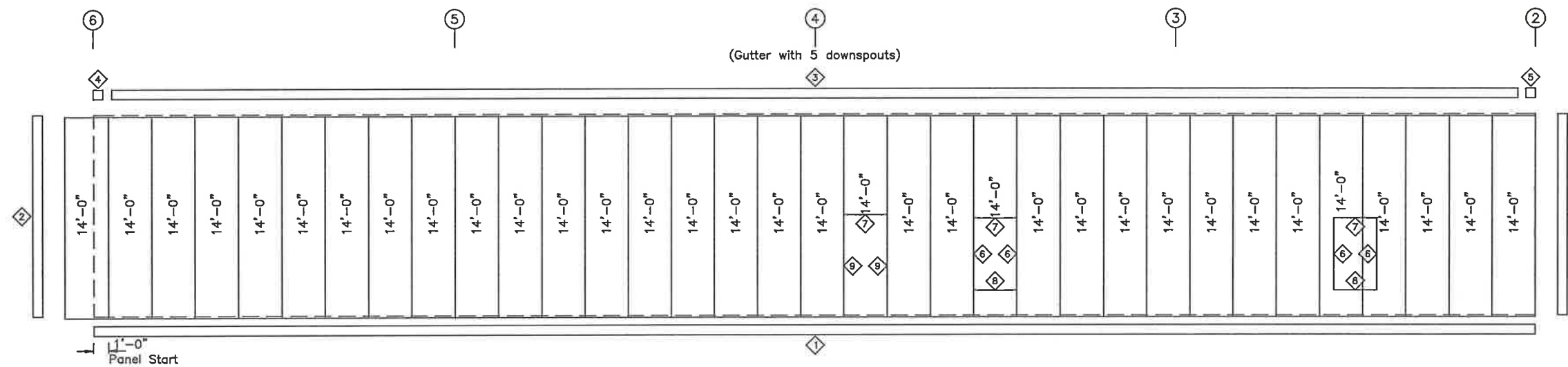

SIDEWALL SHEETING & TRIM: FRAME LINE A
PANELS: 26 Ga. R - NEED COLOR

ISSUE	DET	CHK	DATE
UNION LaSTEEL			
CUSTOMER: TRAFICANTE			
JOB NO: 8728	DATE: 8/14/24		
LOCATION: LAKE CITY, FL 32025			
DRAWING NAME: FRAMING & SHEETING LAYOUT			
DRAWING NO: PAGE 4.1	DRAWN BY: PS	CHECKED BY: SPW	SCALE: NONE

TRIM TABLE FRAME LINE J			
ID	PART	LENGTH	DETAIL
1	BASE TRM	12'-3"	TRIM_16
2	O/S CORN	10'-2"	TRIM_5
3	GUTTER	12'-0"	TRIM_1
4	GUTEND L	1"	TRIM_2
5	GUTEND R	1"	TRIM_2
6	R JAMB	5'-3"	TRIM_8
7	R HEAD	3'-3"	TRIM_61
8	R HEAD	3'-3"	TRIM_7

MEMBER TABLE FRAME LINE J		
MARK	PART	LENGTH
DJ-100	8X25C16	7'-4"
DH-100	8X25C16	3'-0"
DS-100	8X25C16	3'-0"
G-103	8x25Z16	11'-3 1/2"

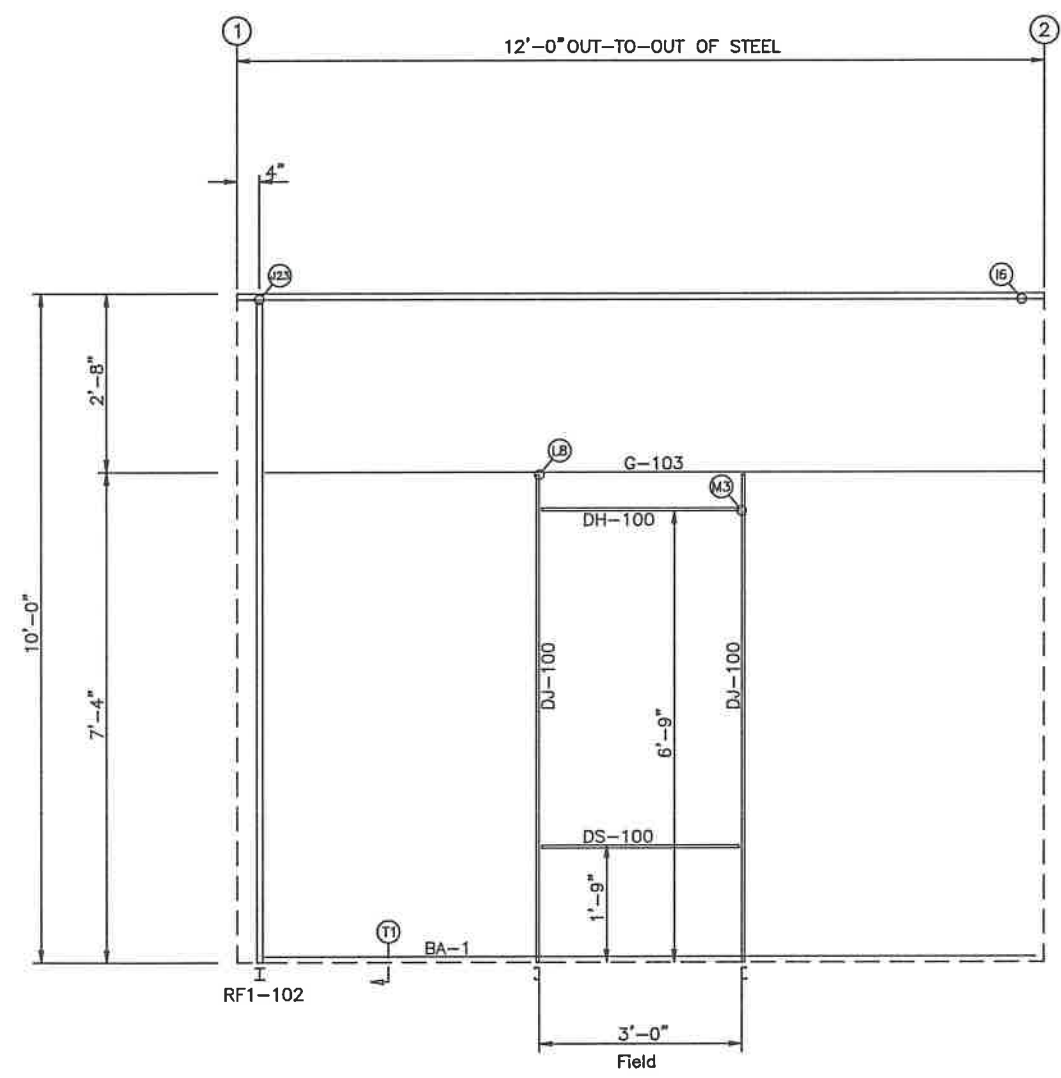

SIDEWALL FRAMING: FRAME LINE J

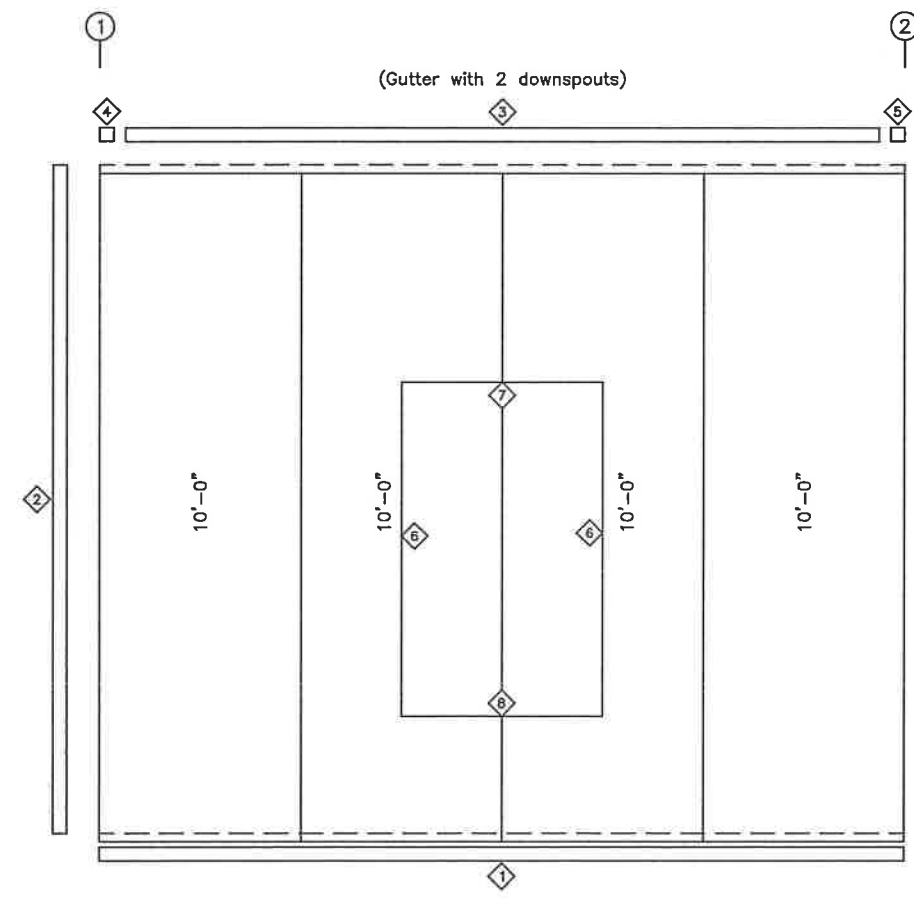

SIDEWALL SHEETING & TRIM: FRAME LINE J
PANELS: 26 Ga. R - NEED COLOR

ISSUE	DET	CHK	DATE
UNION LaSTEEL			
CUSTOMER: TRAFICANTE			
JOB NO: 8728		DATE: 8/14/24	
LOCATION: LAKE CITY, FL 32025			
DRAWING NAME: FRAMING & SHEETING LAYOUT			
DRAWING NO: PAGE 4.2	DRAWN BY: PS	CHECKED BY: SPW	SCALE: NONE

TRIM TABLE FRAME LINE B			
ID	PART	LENGTH	DETAIL
1	BASE TRM	12'-3"	TRIM_16
2	O/S CORN	10'-2"	TRIM_5
3	GUTTER	12'-0"	TRIM_1
4	GUTEND L	1"	TRIM_2
5	GUTEND R	1"	TRIM_2
6	R JAMB	7'-3"	TRIM_8
7	R HEAD	3'-3"	TRIM_61

MEMBER TABLE FRAME LINE B		
MARK	PART	LENGTH
G-103	8x25Z16	11'-3 1/2"

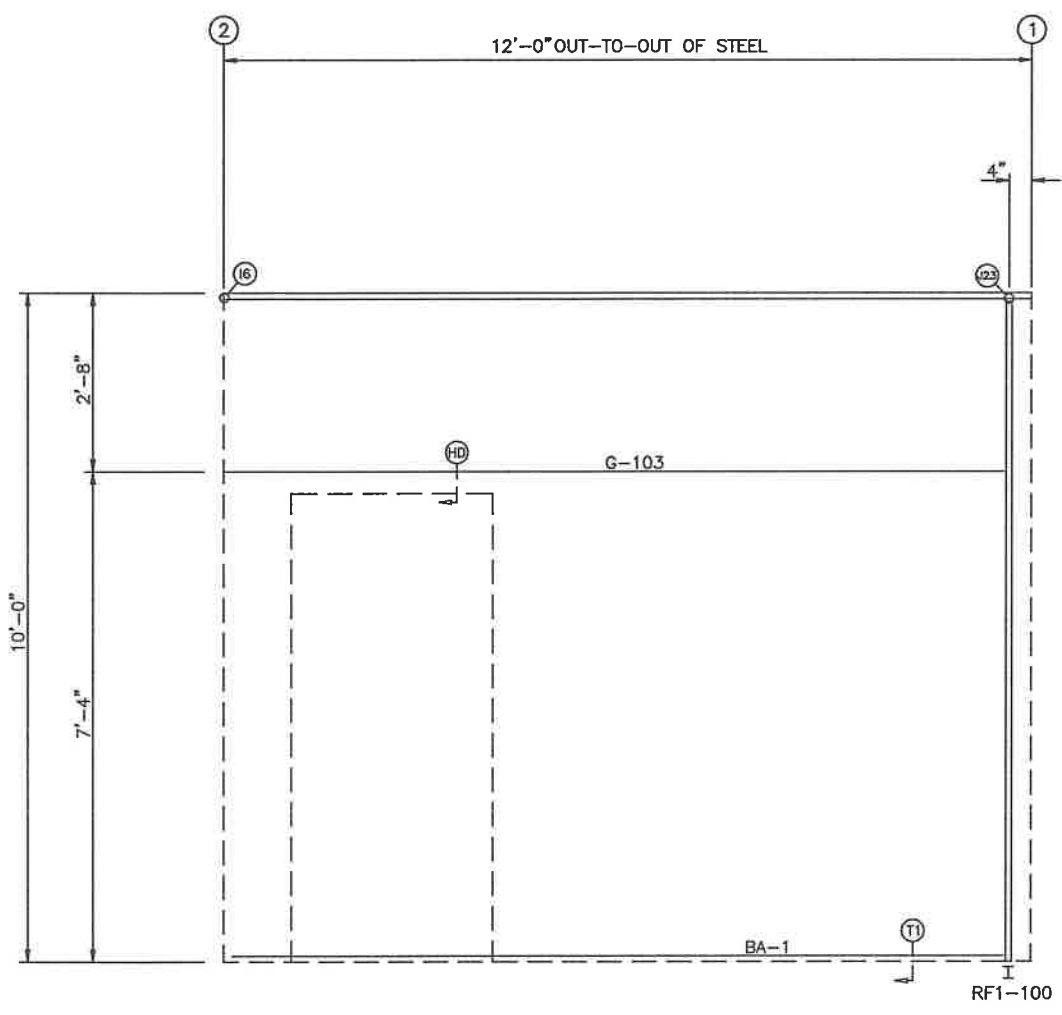

SIDEWALL FRAMING: FRAME LINE B

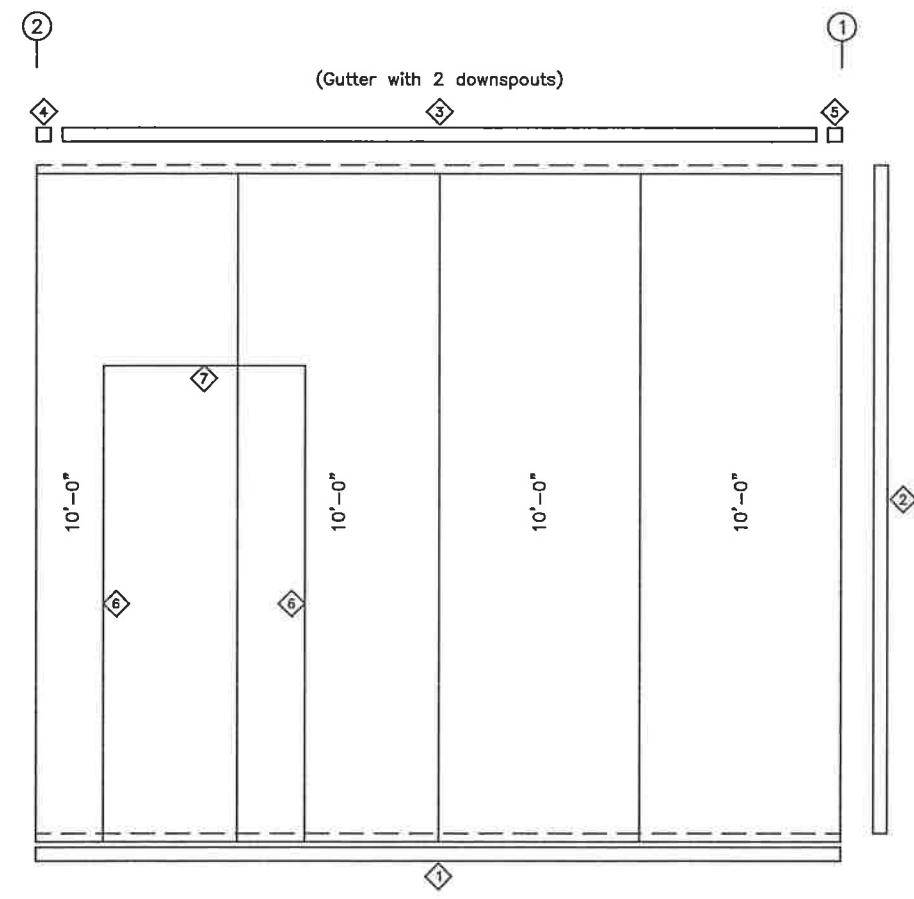

SIDEWALL SHEETING & TRIM: FRAME LINE B
PANELS: 26 Ga. R - NEED COLOR

ISSUE	DET	CHK	DATE
UNION LaSTEEL			
CUSTOMER: TRAFICANTE			
JOB NO: 8728	DATE: 8/14/24		
LOCATION: LAKE CITY, FL 32025			
DRAWING NAME: FRAMING & SHEETING LAYOUT			
DRAWING NO: PAGE 4.3	DRAWN BY: PS	CHECKED BY: SPW	SCALE: NONE

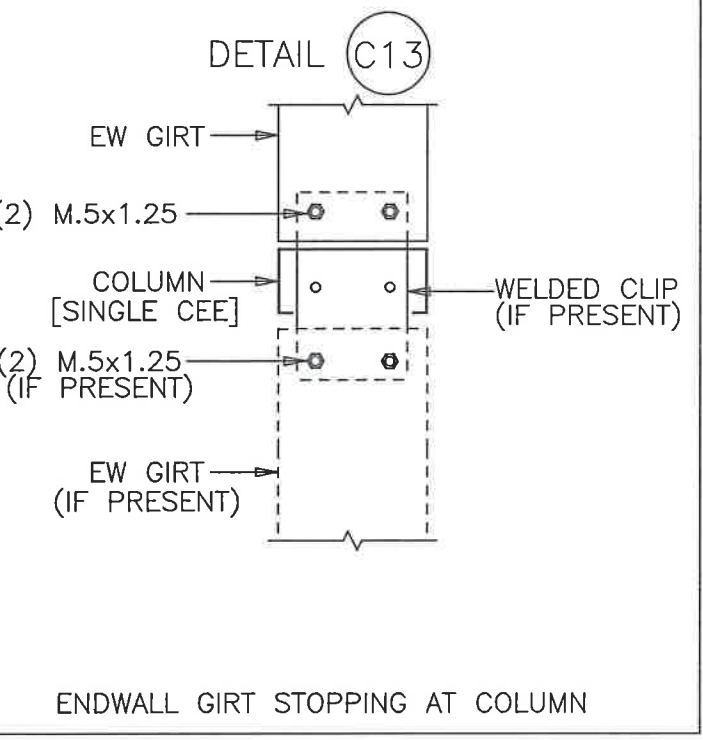
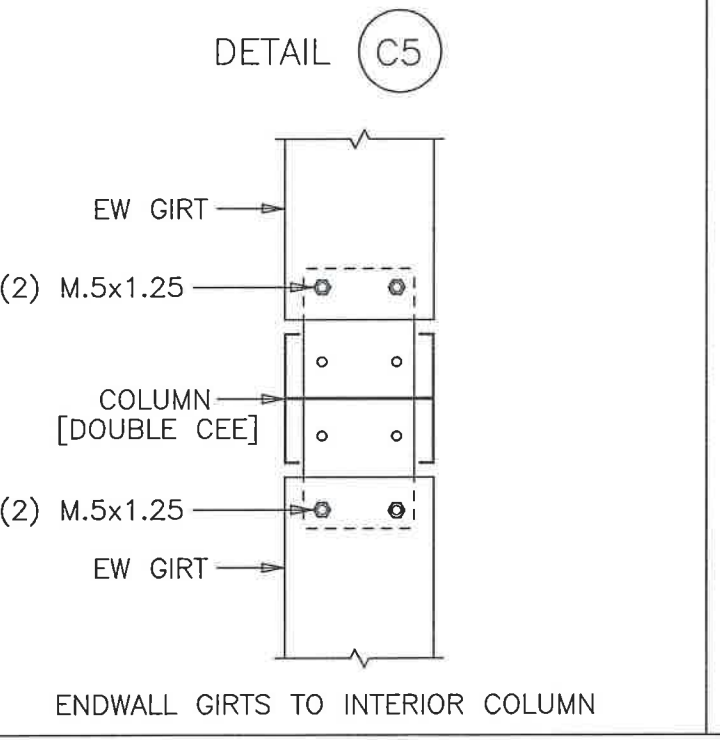
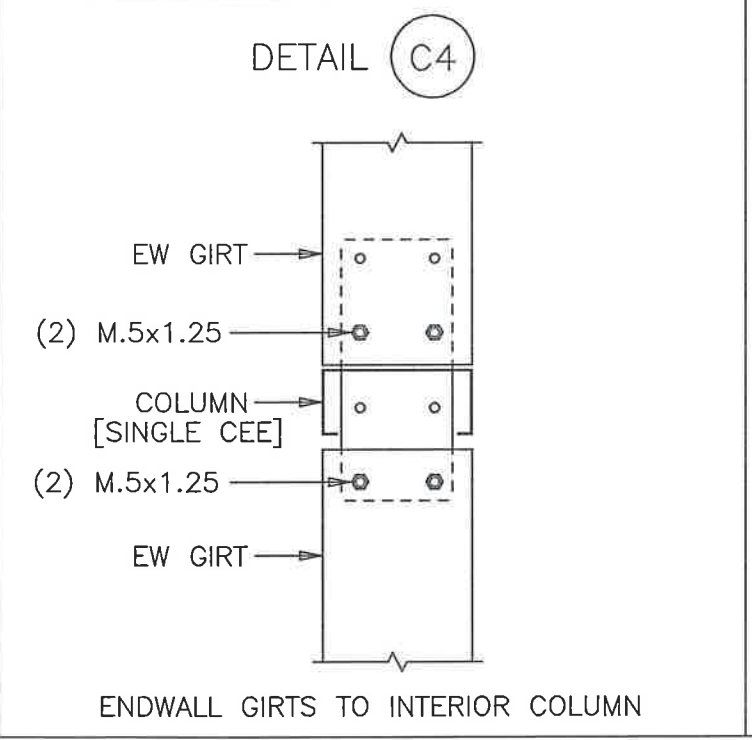
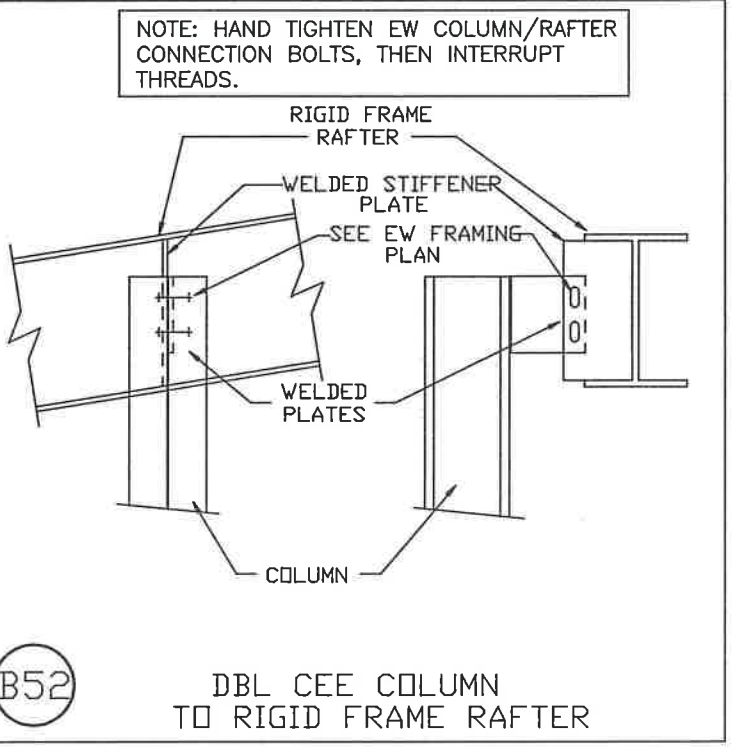
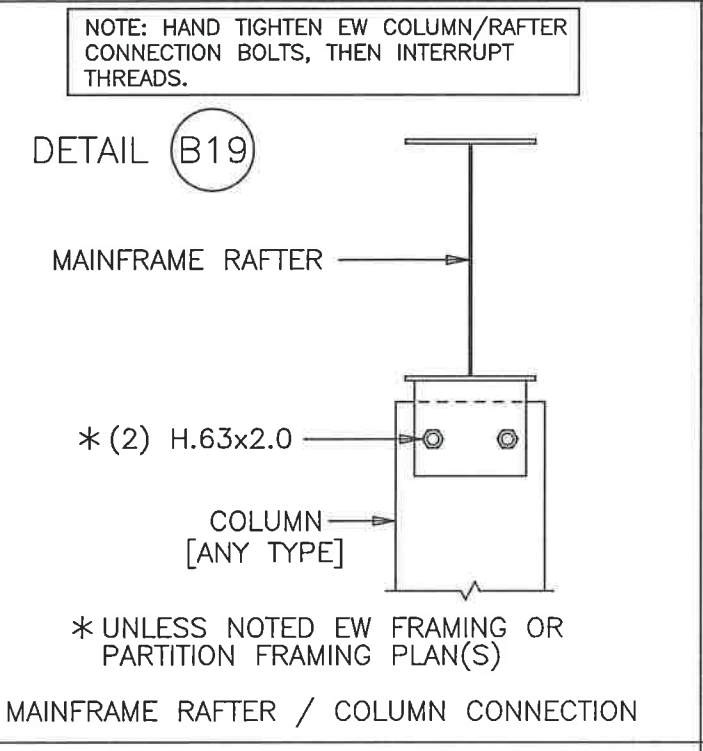
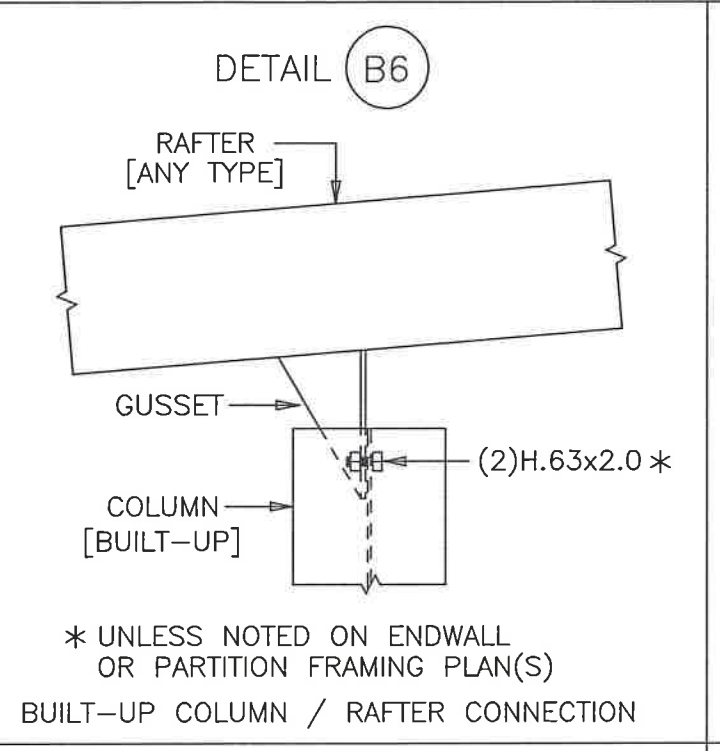
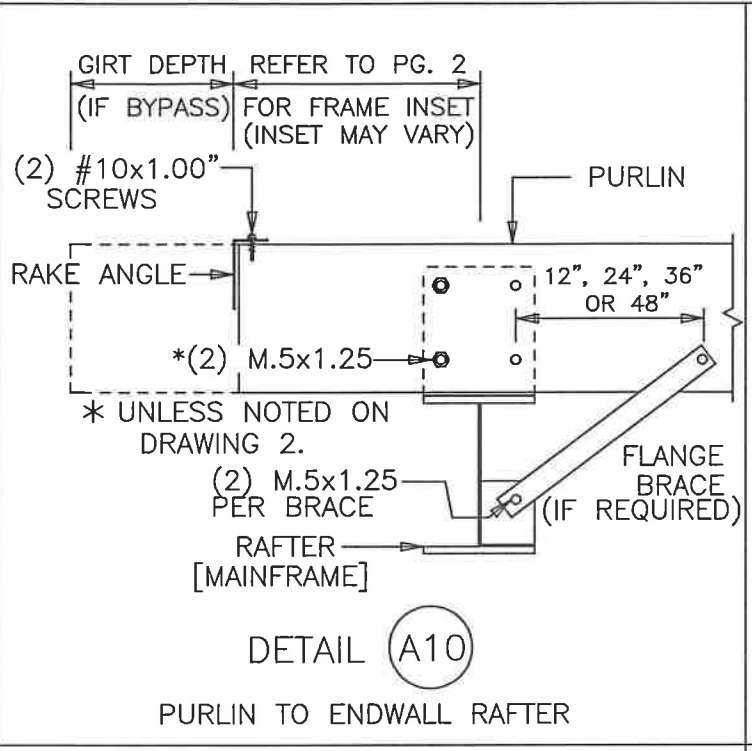

ISSUE	DET	CHK	DATE
UNION LaSTEEL			
CUSTOMER: TRAFICANTE			
JOB NO: 8728	DATE: 8/14/24		
LOCATION: LAKE CITY, FL 32025			
DRAWING NAME: FRAMING DETAILS			
DRAWING NO: PAGE 5	DRAWN BY: PS	CHECKED BY: SPW	SCALE: NONE

DETAIL C14

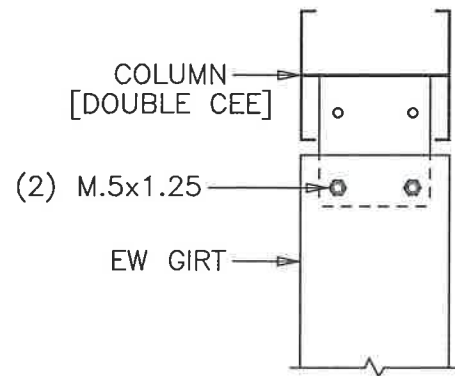

ENDWALL GIRT STOPPING AT COLUMN

DETAIL C15

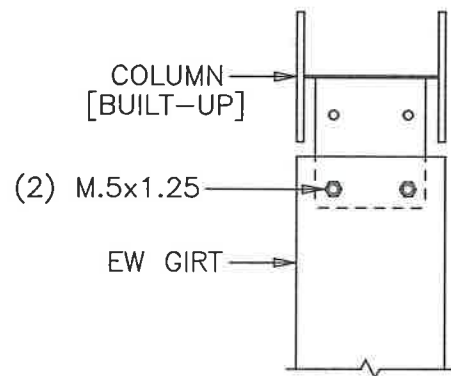

ENDWALL GIRT STOPPING AT COLUMN

DETAIL D13

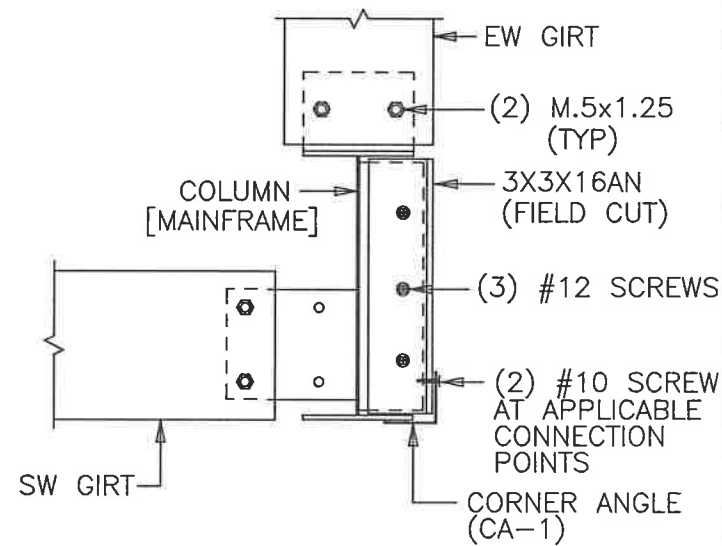

GIRT CONNECTIONS AT EXPANDABLE ENDWALL

DETAIL D14

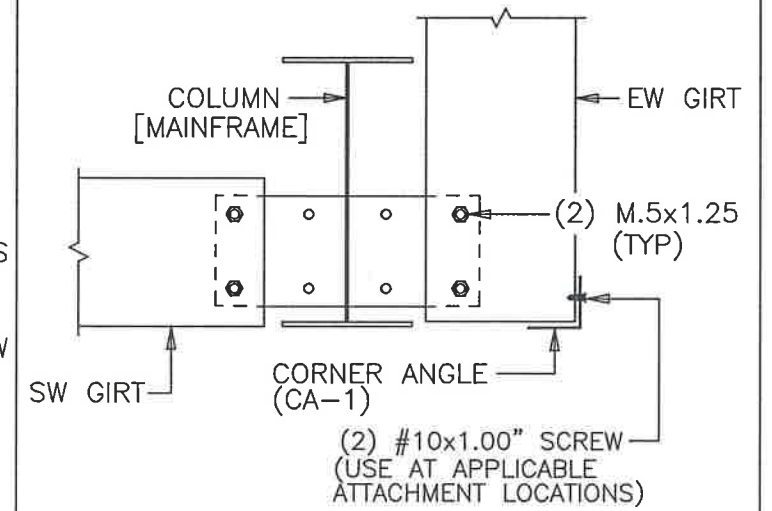

GIRT CONNECTIONS AT EXPANDABLE ENDWALL

DETAIL E3

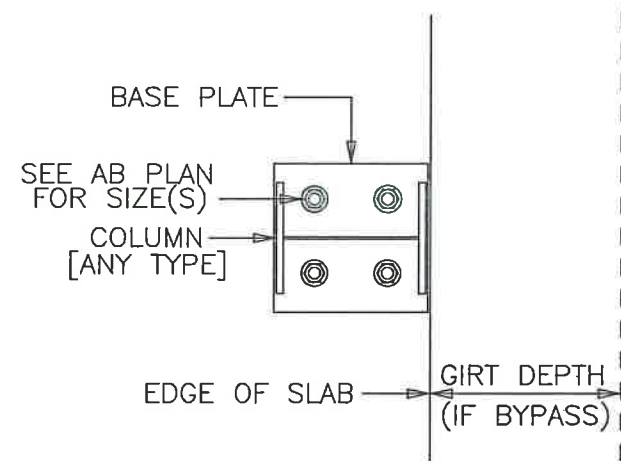

ENDWALL COLUMN BASE DETAIL

DETAIL E4

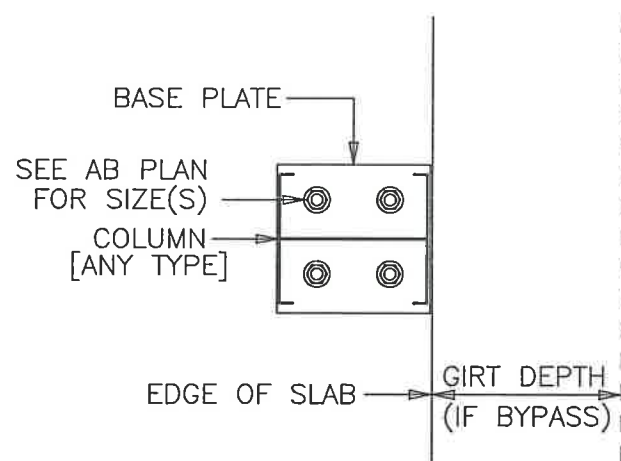

ENDWALL COLUMN BASE DETAIL

DETAIL E5

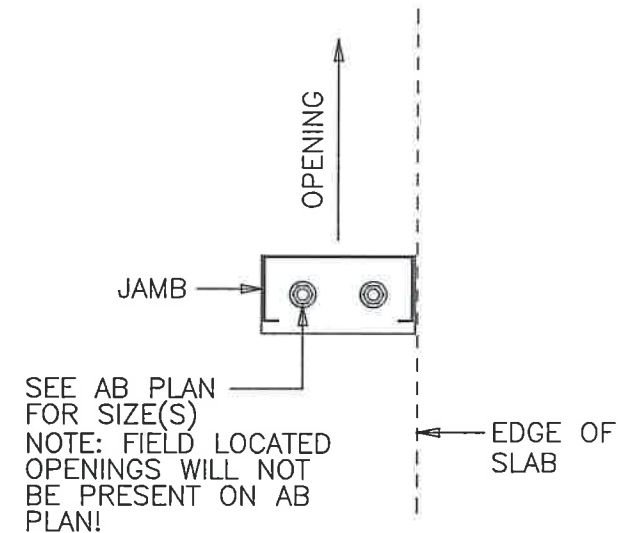

FRAMED OPENING JAMB BASE DETAIL

DETAIL E8

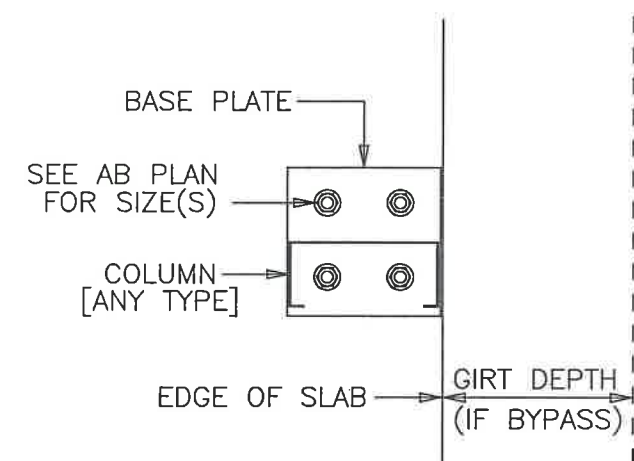

ENDWALL COLUMN BASE DETAIL

ISSUE	DET	CHK	DATE
UNION LaSTEEL			
CUSTOMER: TRAFICANTE			
JOB NO: 8728	DATE: 8/14/24		
LOCATION: LAKE CITY, FL 32025			
DRAWING NAME: FRAMING DETAILS			
DRAWING NO: PAGE 5.1	DRAWN BY: PS	CHECKED BY: SPW	SCALE: NONE

DETAIL (F10)

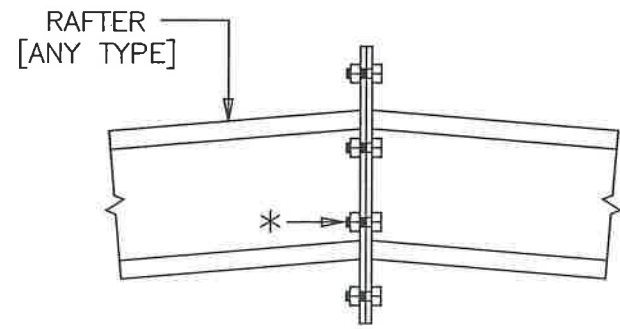

* SEE EW FRAMING PLAN FOR SIZE AND QUANTITY OF BOLTS.

RAFTER DETAIL AT RIDGE

DETAIL (G2)

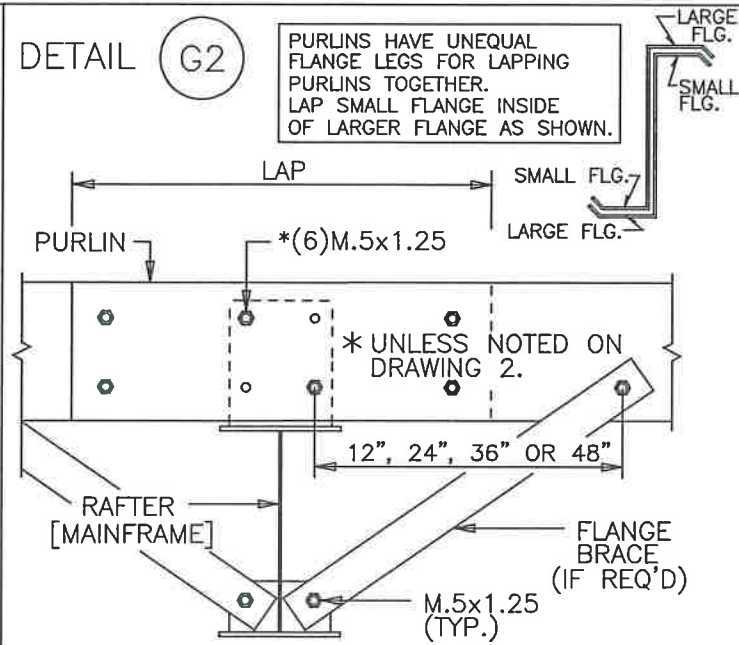

PURLIN TO MAINFRAME RAFTER

(G26) WELDED ANTI-ROLL CLIP

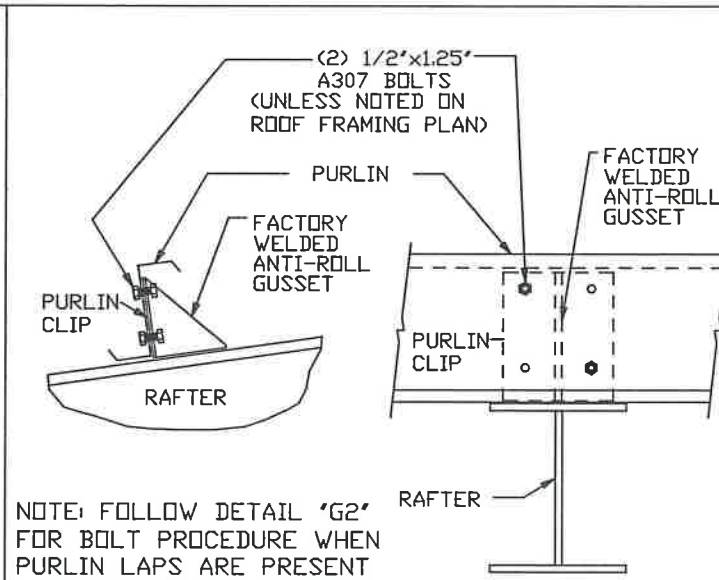

DETAIL (H6)

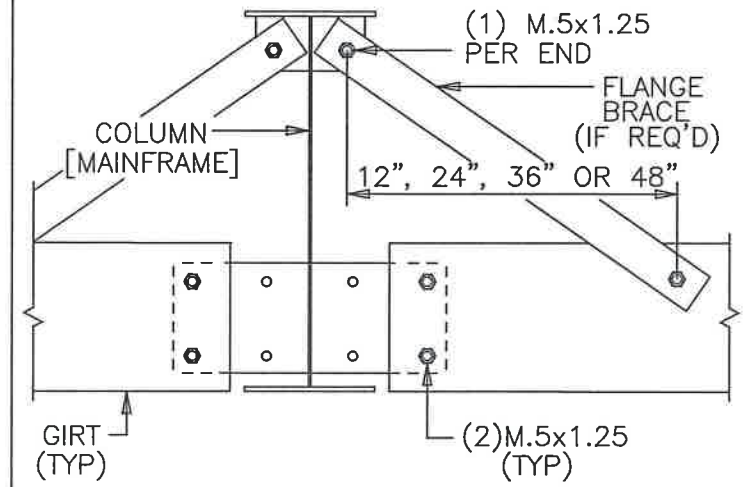

GIRT TO MAINFRAME COLUMN

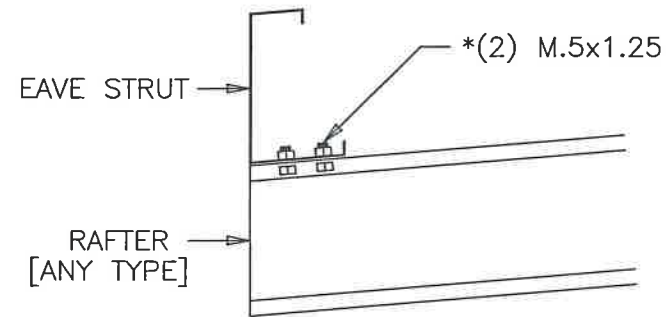

*UNLESS NOTED ON DRAWING 2.

(I6) EAVE STRUT CONNECTION AT ENDWALL

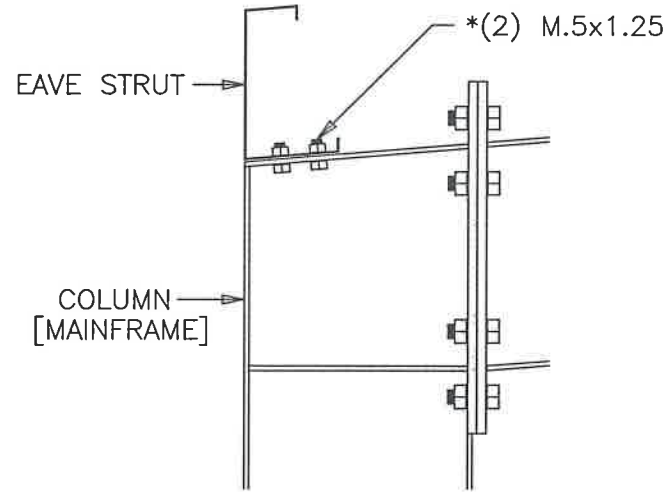

(J1) EAVE STRUT CONNECTION AT MAINFRAME

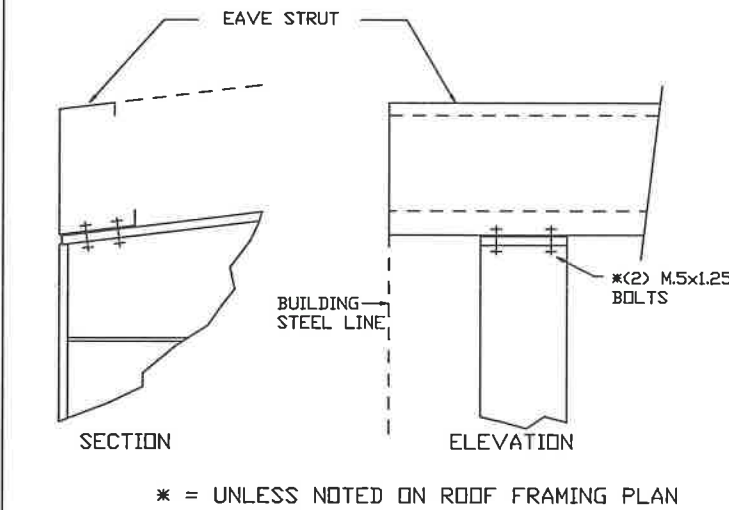

(J23) EAVE STRUT TO RIGID FRAME

DETAIL (K3)

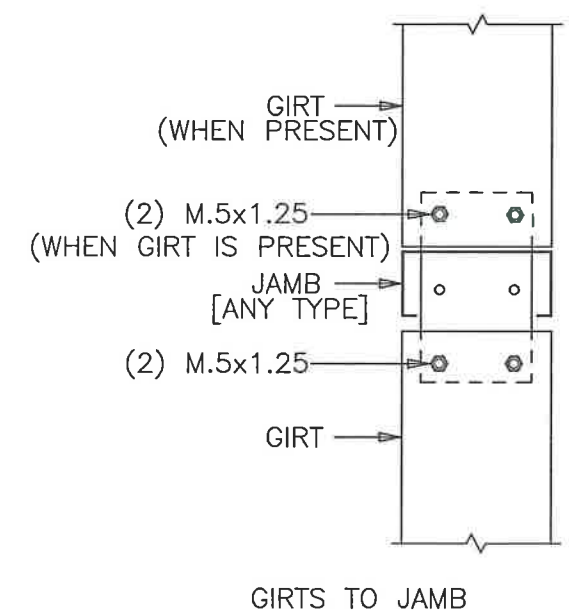

GIRTS TO JAMB

ISSUE	DET	CHK	DATE
UNION LaSTEEL			
CUSTOMER: TRAFICANTE			
JOB NO: 8728	DATE: 8/14/24		
LOCATION: LAKE CITY, FL 32025			
DRAWING NAME: FRAMING DETAILS			
DRAWING NO: PAGE 5.2	DRAWN BY: PS	CHECKED BY: SPW	SCALE: NONE

DETAIL (L8)

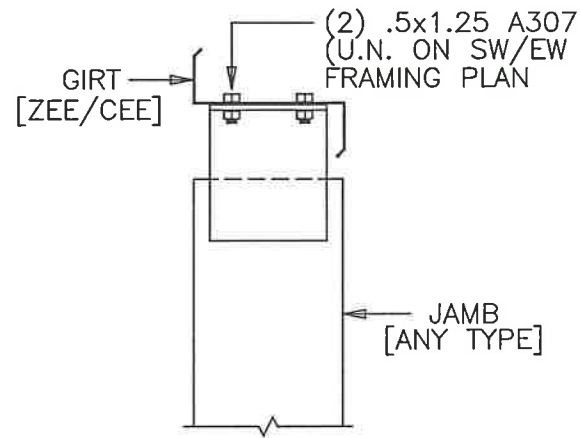

FRAMED OPENING JAMB TO GIRT

DETAIL (L100)

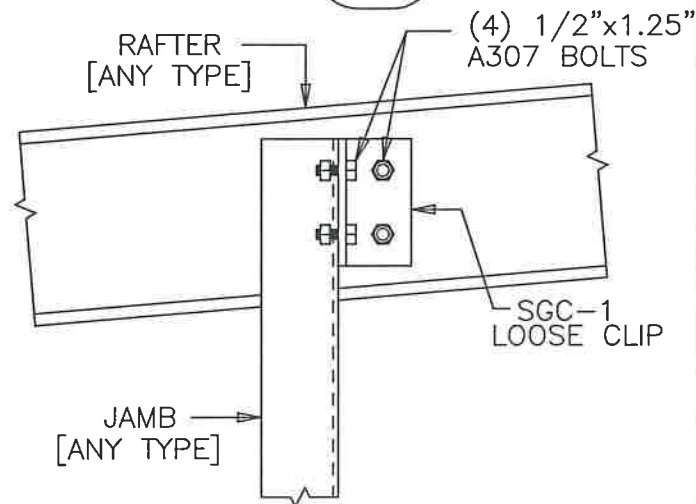

* UNLESS NOTED ON EW FRAMING PLAN

JAMB/COLUMN TO BYPASS EW RAFTER

NOTE: HAND TIGHTEN JAMB/RAFTER CONNECTION BOLTS, THEN INTERRUPT THREADS.

DETAIL (L103)

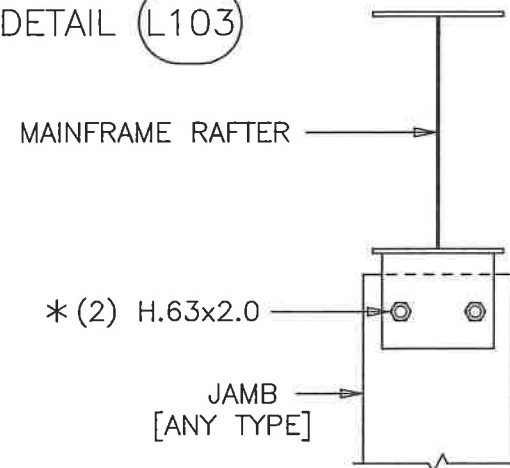

* UNLESS NOTED EW FRAMING OR PARTITION FRAMING PLAN(S)

MAINFRAME RAFTER / DOOR JAMB CONN.

DETAIL (L108)

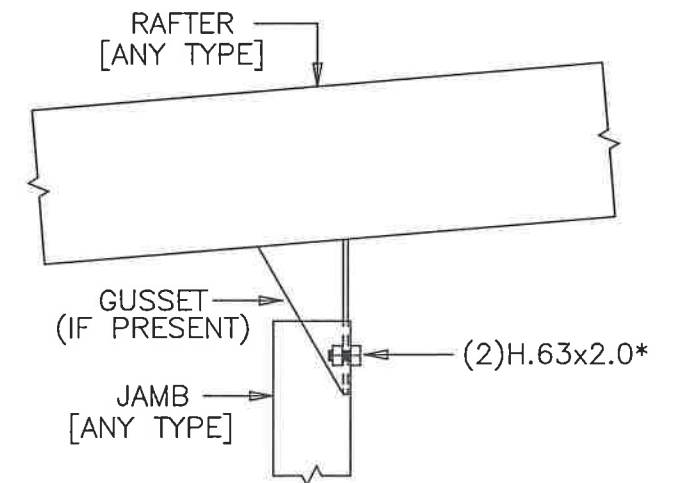

* UNLESS NOTED ON EW FRAMING PLAN

JAMB / RAFTER CONNECTION

DETAIL (M3)

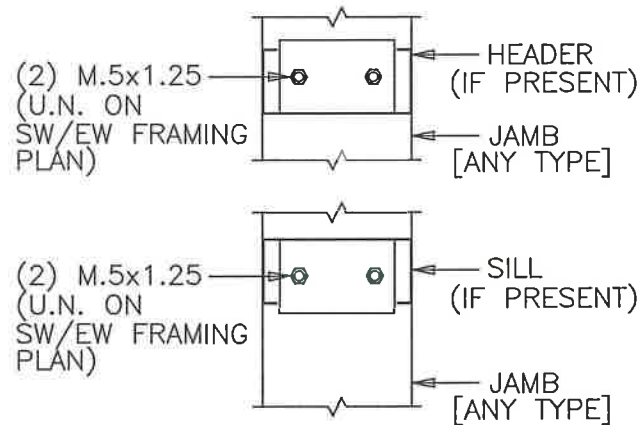

FRAMED OPENING HEADER/SILL TO JAMB

(Q2) CABLE INSTALLATION DETAIL

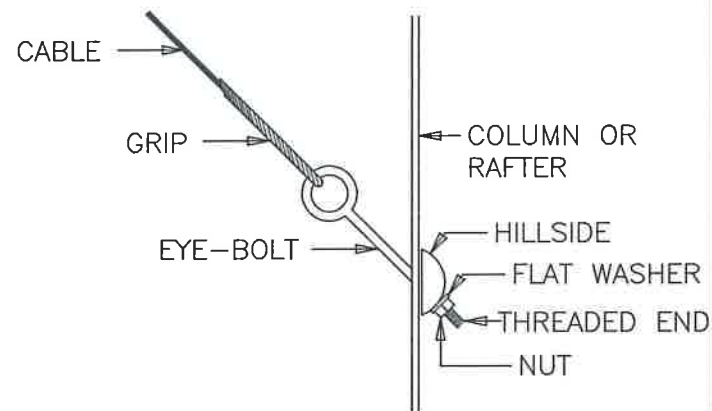

NOTE: WHEN FLUSH GIRTS/PURLINS ARE USED, FIELD SLOT GIRT OR PURLIN AS REQ'D FOR CABLE/ROD PASSAGE THROUGH PURLIN/GIRT.

ISSUE	DET	CHK	DATE
UNION LoSTEEL			
CUSTOMER: TRAFICANTE			
JOB NO: 8728	DATE: 8/14/24		
LOCATION: LAKE CITY, FL 32025			
DRAWING NAME: FRAMING DETAILS			
DRAWING NO: PAGE 5.3	DRAWN BY: PS	CHECKED BY: SPW	SCALE: NONE

DETAIL T1

1/4" x 1 1/4" ZINC HAMMER DRIVES
ZAMAK ALLOY (ASTM B633, SC1, TYPE III)
(24" ON CENTER)

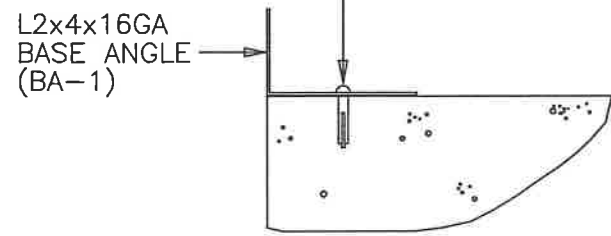

BASE ANGLE DETAIL

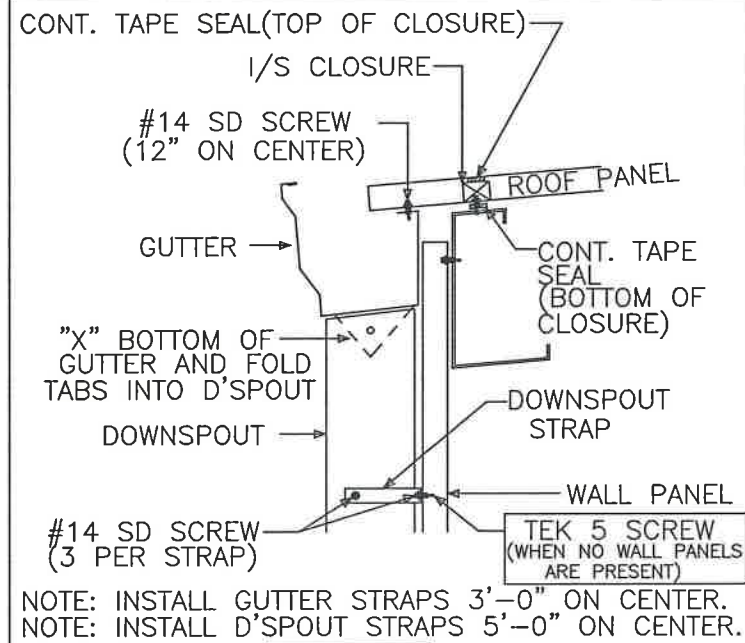

NOTE: INSTALL GUTTER STRAPS 3'-0" ON CENTER.
NOTE: INSTALL D'SPOUT STRAPS 5'-0" ON CENTER.

TRIM_1
GUTTER DETAIL

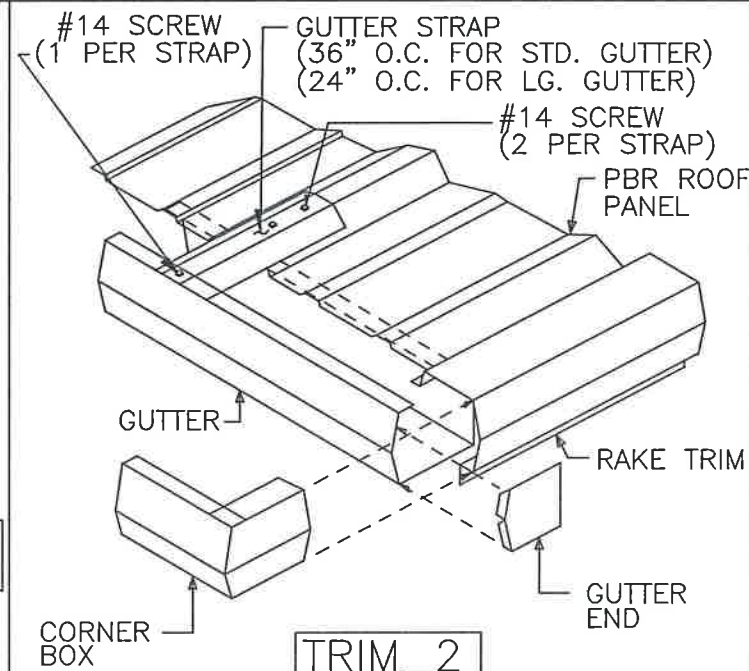

TRIM_2
GUTTER END DETAIL

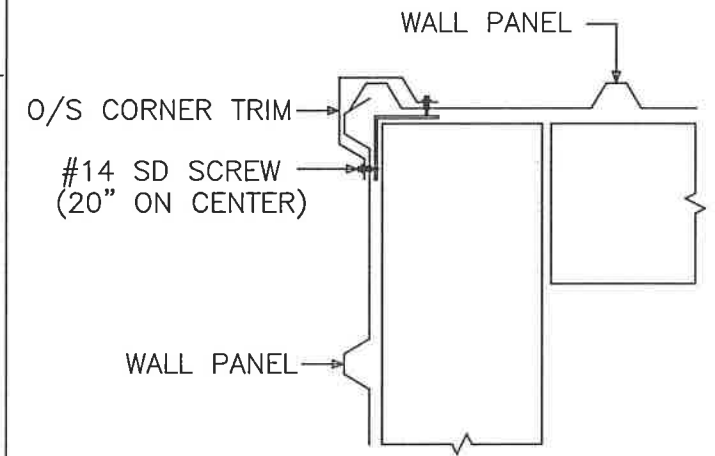

TRIM_5
O/S CORNER DETAIL

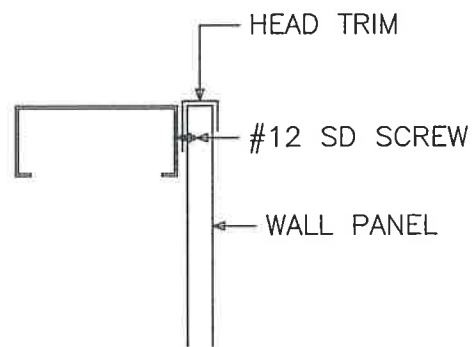

TRIM_7
HEAD TRIM DETAIL AT SILL

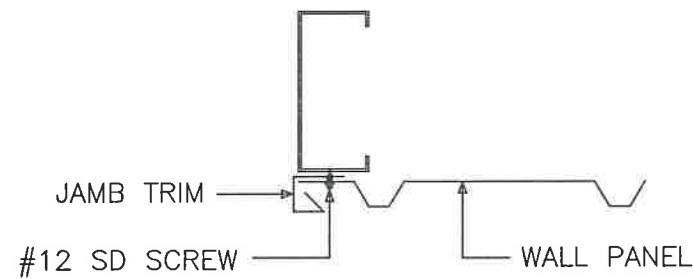

TRIM_8
JAMB TRIM DETAIL AT JAMB

ISSUE	DET	CHK	DATE
UNION LaSTEEL			
CUSTOMER: TRAFICANTE			
JOB NO: 8728	DATE: 8/14/24		
LOCATION: LAKE CITY, FL 32025			
DRAWING NAME: FRAMING DETAILS			
DRAWING NO: PAGE 5.4	DRAWN BY: PS	CHECKED BY: SPW	SCALE: NONE

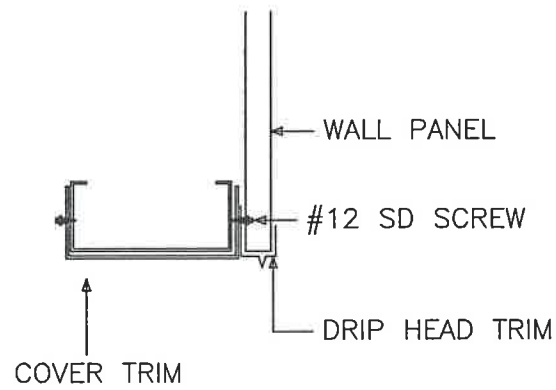

TRIM_10

COVER TRIM DETAIL AT HEADER

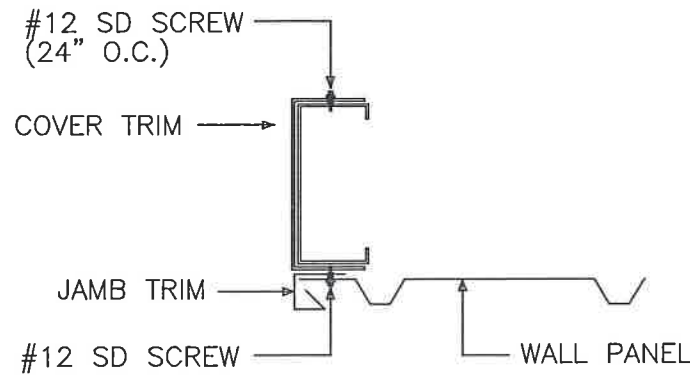

TRIM_11

COVER TRIM DETAIL AT JAMB

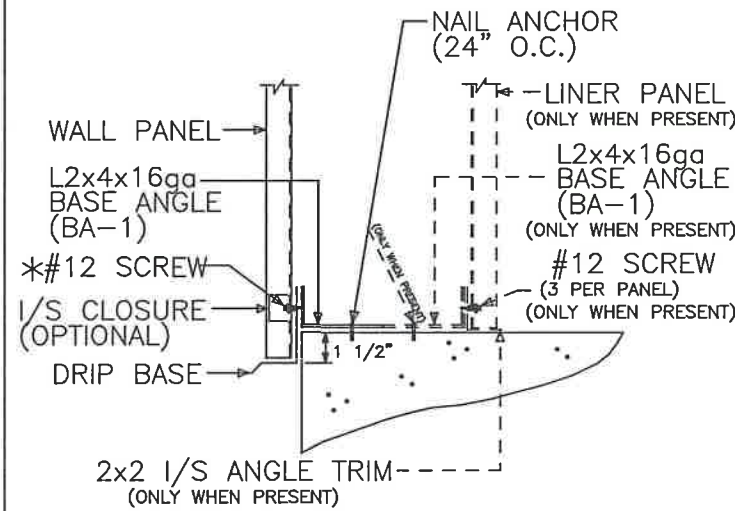

* = 6 PER PANEL FOR STANDARD PBR
3 PER PANEL FOR REV. ROLLED PBR

TRIM_16 BASE TRIM DETAIL

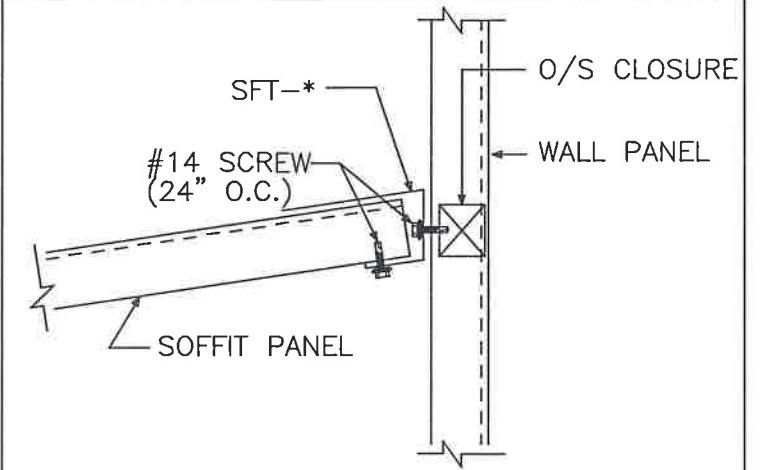

* = 3 FOR PBR SOFFIT
4 FOR PBU SOFFIT

TRIM_23

SOFFIT TRIM DETAIL AT WALL PANEL

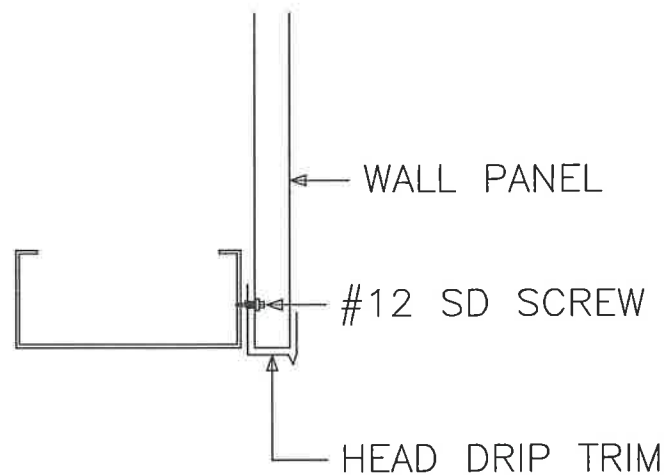

TRIM_61

HEAD TRIM DETAIL AT HEADER

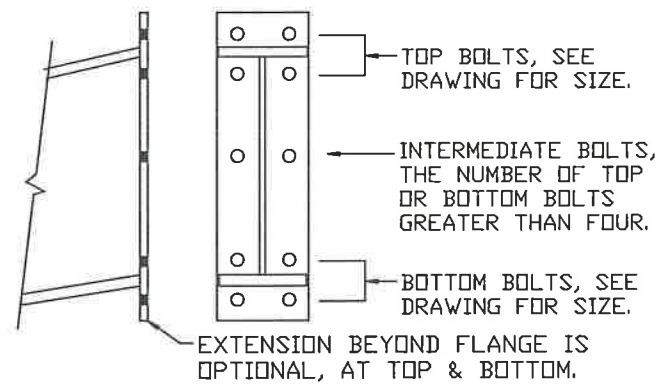

BOLTED END PLATE CONNECTION

STRUCTURAL BOLTED CONNECTIONS

REFER TO COVER PAGE "GENERAL NOTES" PARAGRAPH "C", SECTION "9" FOR INSTRUCTIONS ON TIGHTENING ALL A325 AND A490 CONNECTION BOLTS.

TRIM NOTES:

- [1] SEAL TRIM SPLICES WITH TUBE CAULK.
- [2] SECURE GUTTER SPLICES AND END PLUGS WITH RIVETS.
- [3] SECURE ALL OTHER ROOF TRIM SPLICES WITH TRIM SCREWS UNLESS NOTED OTHERWISE.
- [4] TRIM SCREWS ARE LOCATED 24" ON CENTER UNLESS NOTED OTHERWISE.
- [5] STD. TRIM SPLICES ARE 3" TOTAL UNLESS NOTED OTHERWISE.

MORTISE PREPPED PERSONNEL DOORS

ALL MORTISE PREPPED PERSONNEL DOORS COME AS RIGHTHAND REVERSED SWING.

(i.e. STANDING ON THE OUTSIDE OF THE BUILDING FACING THE DOOR, THE LOCK WILL BE ON THE LEFTHAND SIDE OF THE DOOR AND THE DOOR WILL SWING OUTWARD FROM THE BUILDING.)

ANY FIELD MODIFICATIONS ARE THE RESPONSIBILITY OF THE ERECTOR AND MBM IS NOT LIABLE FOR LABOR CHARGES NOR DAMAGES DUE TO ERROR.

ISSUE	DET	CHK	DATE
UNION LaSTEEL			
CUSTOMER: TRAFICANTE			
JOB NO: 8728	DATE: 8/14/24		
LOCATION: LAKE CITY, FL 32025			
DRAWING NAME: FRAMING DETAILS			
DRAWING NO: PAGE 5.5	DRAWN BY: PS	CHECKED BY: SPW	SCALE: NONE

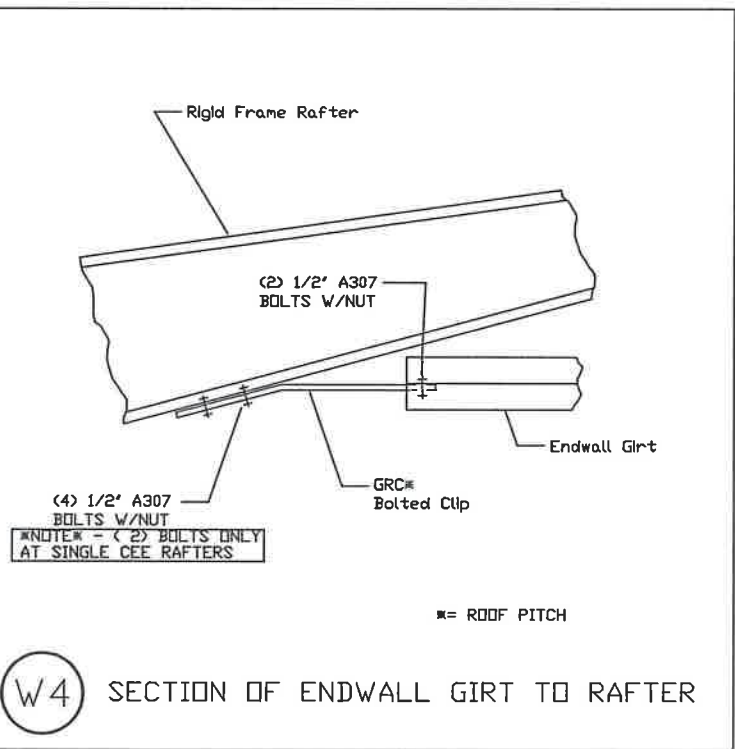
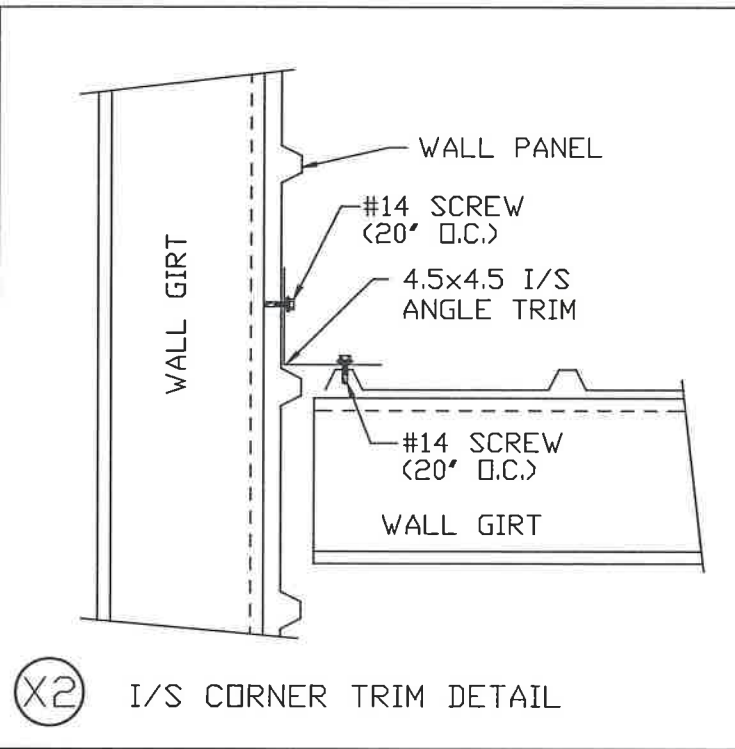
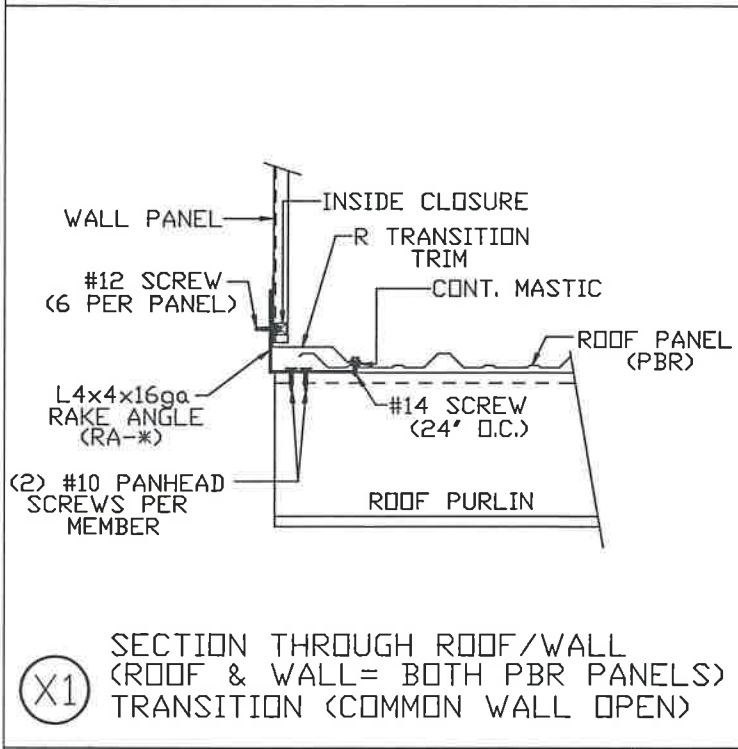

- GENERAL SKYLIGHT NOTES**
- 1) LTP'S (LIGHT TRANSMITTING PANELS) SHALL NOT BE LOCATED END-TO-END AND SHALL NOT BE LOCATED SIDE-TO-SIDE. IT IS RECOMMENDED THAT A MINIMUM OF (3) METAL ROOF PANELS BE INSTALLED BETWEEN EACH LTP SIDELAP.
 - 2) METAL ROOF PANELS ARE NOT TO BE INSTALLED USING A SIMPLE-SPAN CONDITION. IT IS RECOMMENDED THAT A MIN. OF (3) ROOF FRAMING MEMBERS, PREFERABLY (4), SUPPORT ALL METAL ROOF PANELS WHERE ROOF PANELS HAVE BEEN CUT (FACTORY OR FIELD) TO ALLOW FOR LTP INSTALLATION.
 - 3) LTP'S SHALL NOT BE INSTALLED EAVE-TO-PEAK OR EAVE-TO-EAVE (ONE LTP PER SINGLE "RUN" OF SHEETING).
 - 4) BUILDINGS WITH LESS THAN ~60'-0" OF ROOF PANELS IN A SINGLE "RUN" TYPICALLY ARE ONLY ALLOWED (1) LTP PER "RUN".
 - 5) ANY INSTALLATIONS FOR LTP'S OUTSIDE OF THESE GUIDLINES AND THE DETAILS PROVIDED BY THE M.B.M. REMOVE SAID M.B.M. FROM ANY LIABILITIES OR FAULTS DESPITE CLAIMS AGAINST M.B.M.
 - 6) FOR ALL LTP'S PROVIDED BY M.B.M., LIGHT STONE FASTENERS WILL BE PROVIDED FOR A CLOSE MATCH TO LTP COLOR. THIS INCLUDES WALL & ROOF LTP'S.
 - 7) DO NOT STEP ON LTP'S ONCE THEY HAVE BEEN INSTALLED! STEPPING ON LPT'S AFTER INSTALLATION MAY RESULT IN INJURY OR DEATH!

BUILT-UP MEMBER LEGEND

BEAM TYPE	BEAM DEPTH	FLANGE WIDTH	FLANGE THK.	WEB THK.
B	08	5	4	1
B= BUILT-UP	08 = 8" 10 = 10" 12 = 12" 14 = 14" ETC.	5, 6, 8, 10 OR 12 (INCHES) MEASURED IN 16ths. (4 = 1/4", 5 = 5/16" ETC.)		1 = 10ga 3 = 3/16" ETC.

ISSUE	DET	CHK	DATE
UNION LaSTEEL			
CUSTOMER: TRAFICANTE			
JOB NO: 8728	DATE: 8/14/24		
LOCATION: LAKE CITY, FL 32025			
DRAWING NAME: FRAMING DETAILS			
DRAWING NO: PAGE 5.6	DRAWN BY: PS	CHECKED BY: SPW	SCALE: NONE

TRIM TABLE			
ROOF PLAN			
ID	PART	LENGTH	DETAIL
1	RID FLSH	10'-3"	
2	GUTEND L	1"	TRIM_2
3	GUTTER	20'-3"	TRIM_1
4	GUTEND R	1"	TRIM_2
5	RID FLSH	2'-0"	
6	RST10	4'-5"	TRIM_24

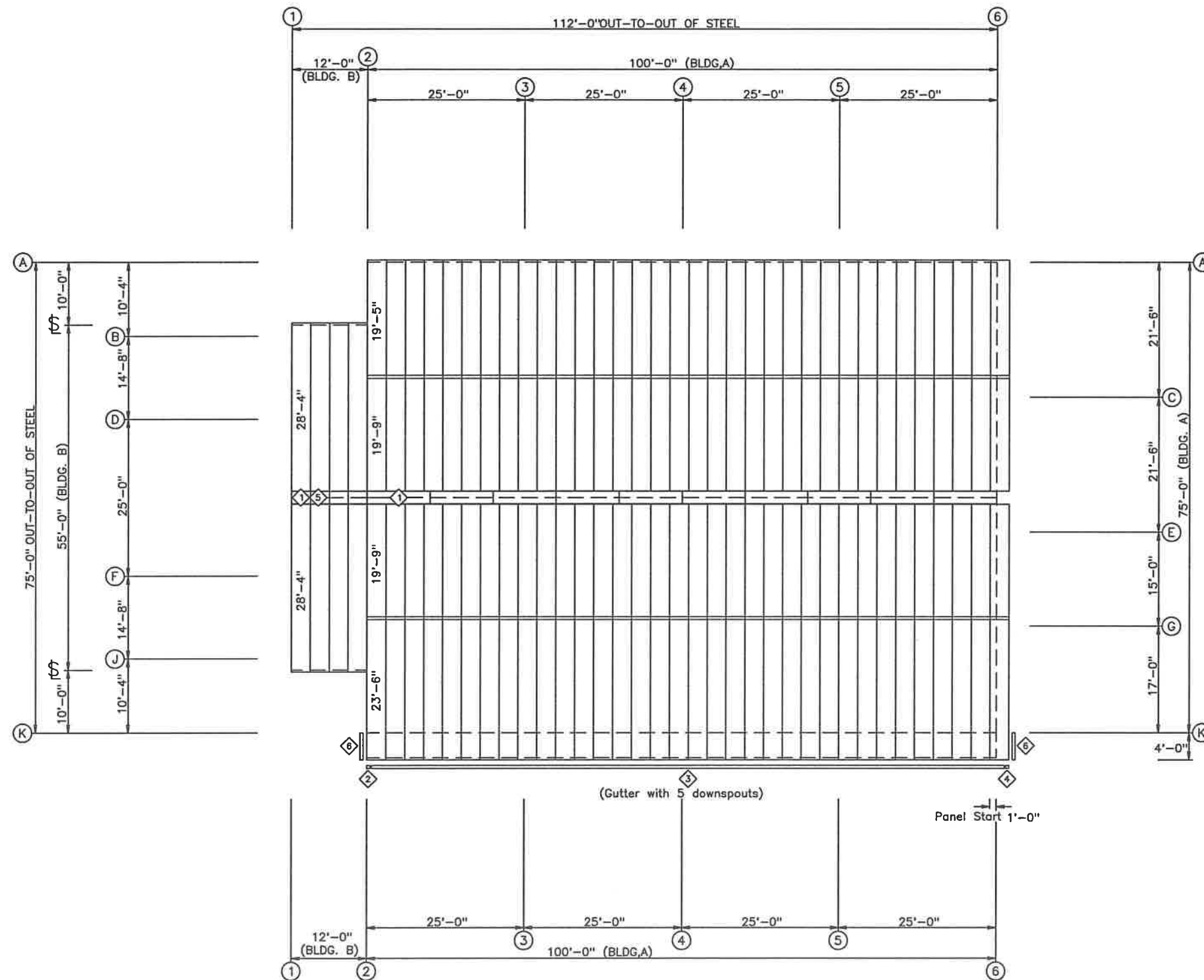

ROOF SHEETING PLAN
 PANELS: 26 GA. PBR - GALVALUME

ISSUE	DET	CHK	DATE
UNION LaSTEEL			
CUSTOMER: TRAFICANTE			
JOB NO: 8728	DATE: 8/14/24		
LOCATION: LAKE CITY, FL 32025			
DRAWING NAME: ROOF PANELS & TRIM			
DRAWING NO: PAGE 6	DRAWN BY: PS	CHECKED BY: SPW	SCALE: NONE

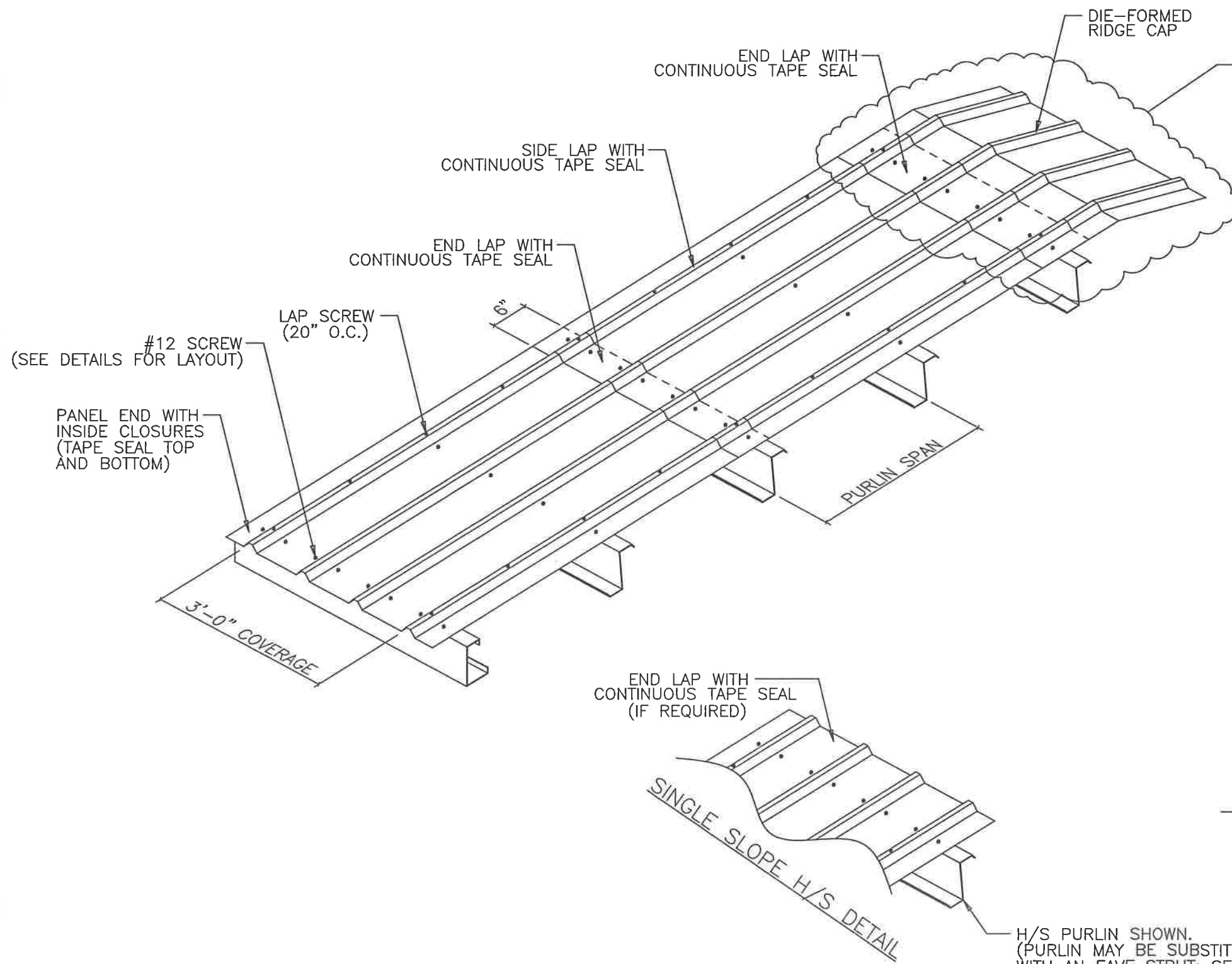

D/F RIDGE SHOWN (GABLED).
SEE BELOW FOR ALTERNATE
DETAIL TO BE VIEWED WHEN
BUILDING IS SINGLE SLOPED.

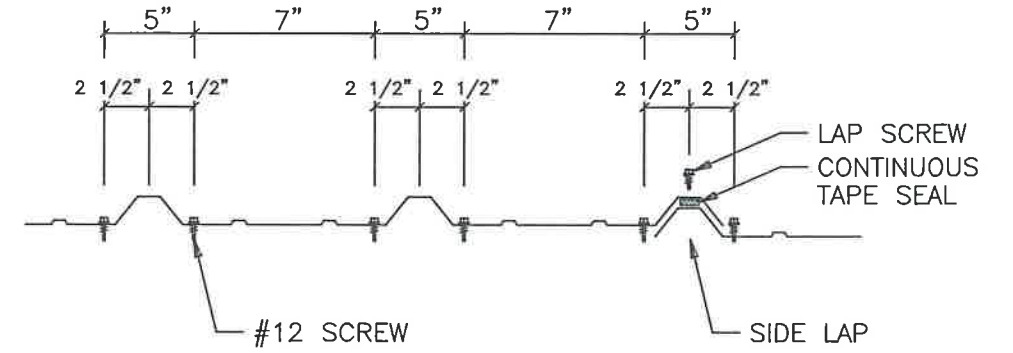

PANEL ATTACHMENT AT PANEL END
(PEAK PURLIN, EAVE STRUT, AND PANEL END LAPS)

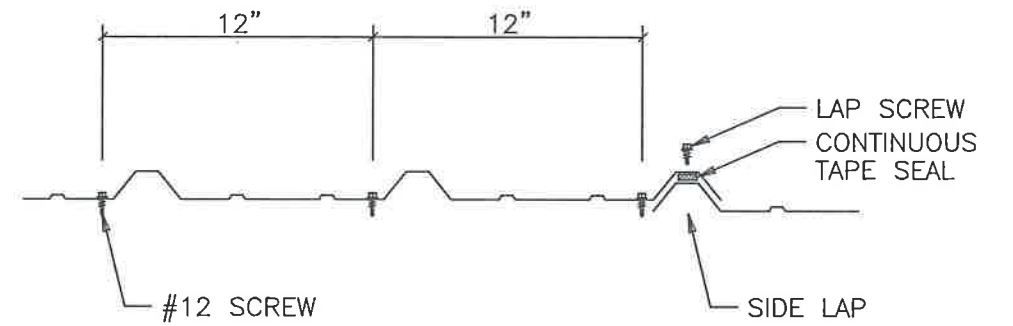

PANEL ATTACHMENT AT INTERMEDIATE MEMBERS

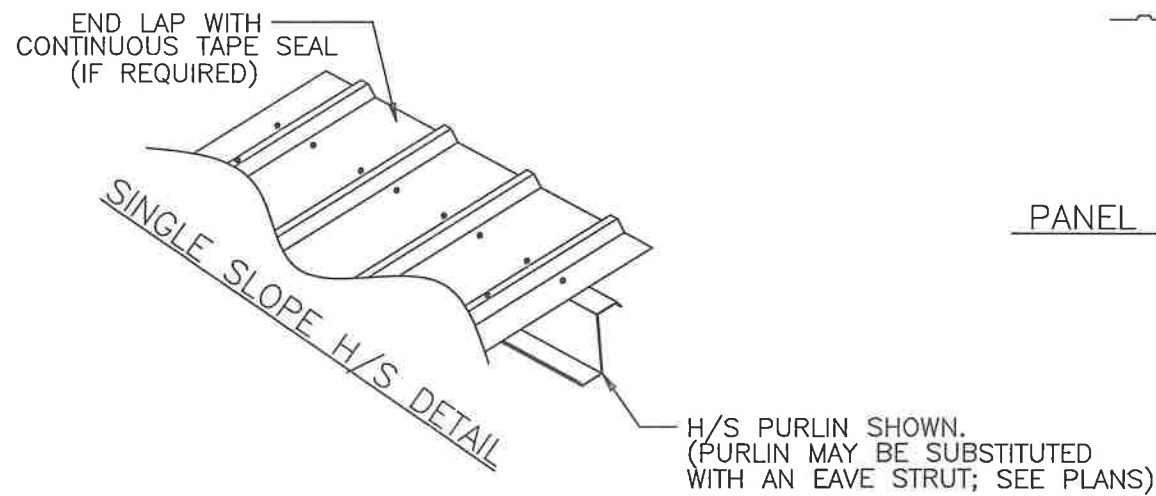

NOTES:

- [1] ALL END LAPS MUST BE A MINIMUM OF 6".
- [2] METAL SHAVINGS MUST BE SWEEPED FROM THE ROOF EACH DAY DURING ERECTION TO PREVENT SURFACE RUSTING.
- [3] TAPE SEAL MUST BE APPLIED WITH NO GAPS OR BREAKS.
- [4] #12 SCREWS ARE USED TO ATTACH THE PANEL TO THE PURLINS. #14 LAP SCREWS ARE USED AT THE PANEL-TO-PANEL ATTACHMENTS. ALL FASTENERS ARE SELF-DRILLING.

ISSUE	DET	CHK	DATE
UNION LaSTEEL			
CUSTOMER: TRAFICANTE			
JOB NO: 8728	DATE: 8/14/24		
LOCATION: LAKE CITY, FL 32025			
DRAWING NAME: ROOF PANEL DETAILS			
DRAWING NO: PAGE 6.1	DRAWN BY: RMC	CHECKED BY: SPW	SCALE: NONE

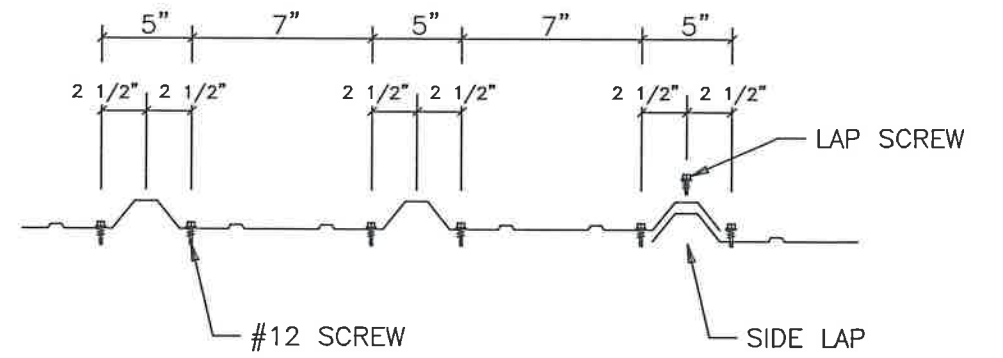
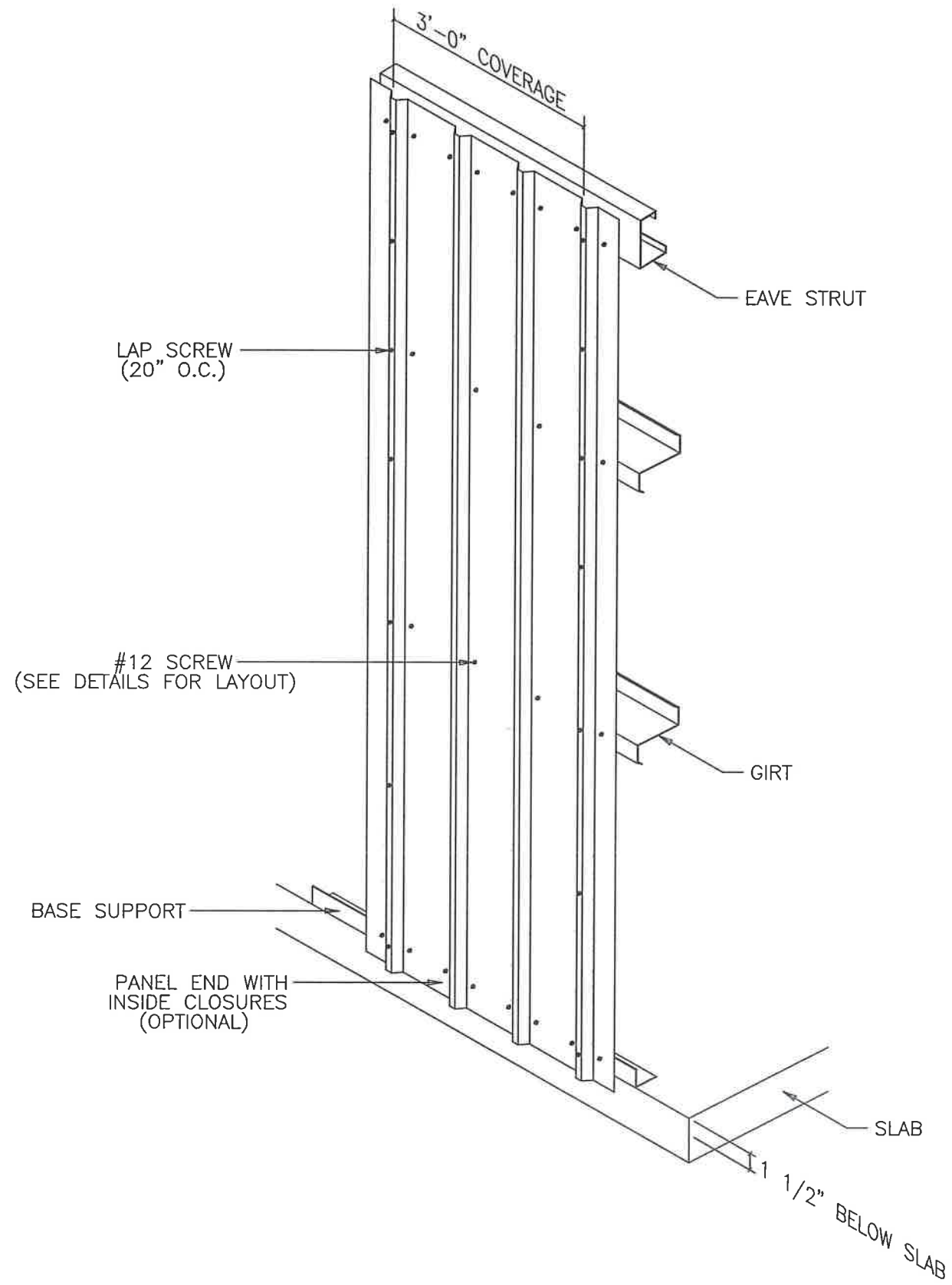

PANEL ATTACHMENT AT PANEL END
(BASE, EAVE STRUT, HEADER, SILL, AND PANEL END LAPS)

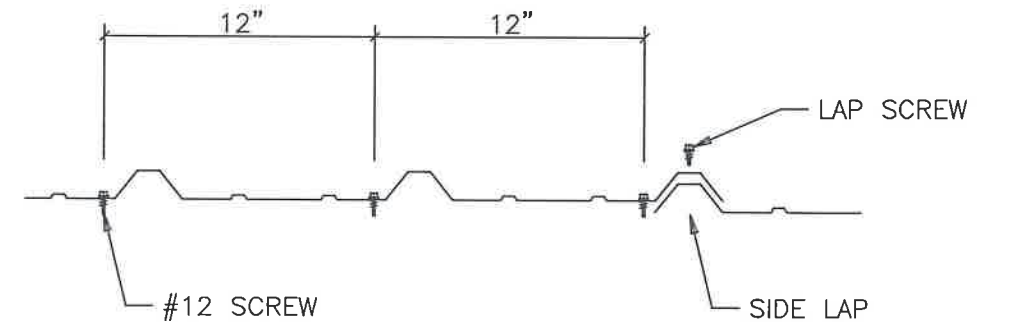

PANEL ATTACHMENT AT INTERMEDIATE MEMBERS

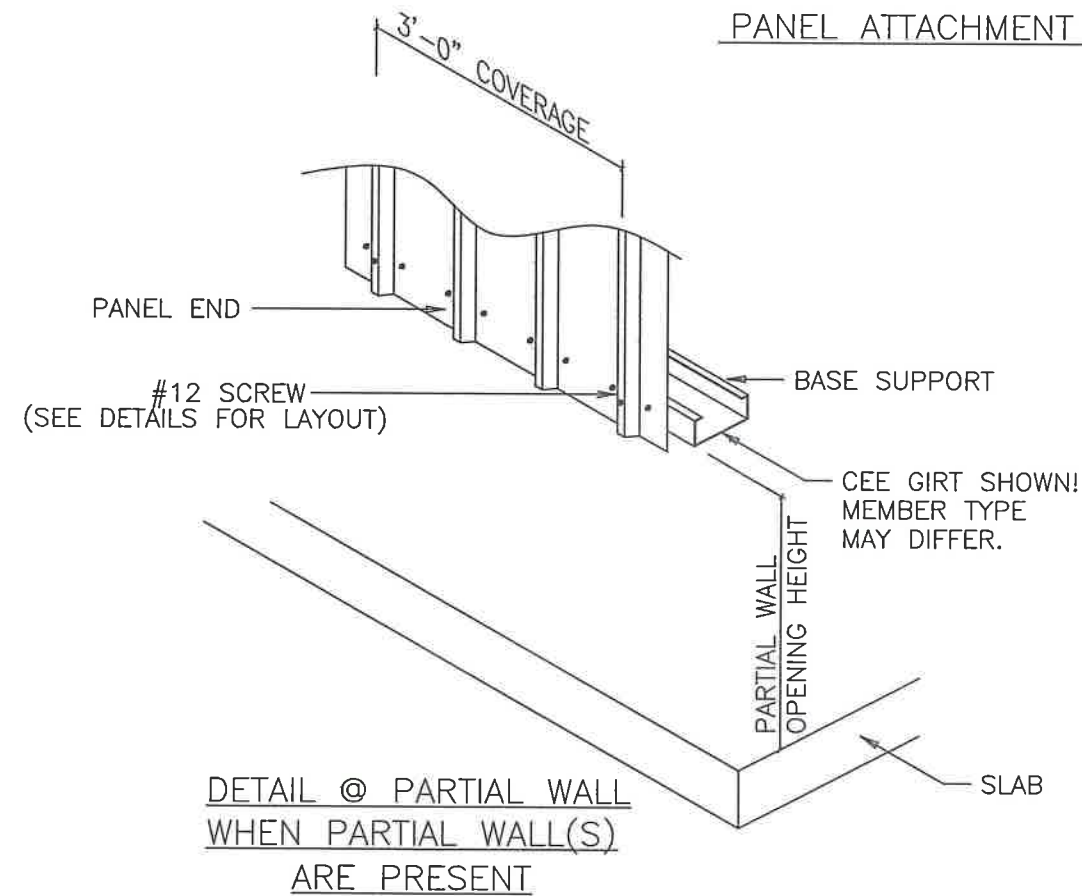

DETAIL @ PARTIAL WALL
WHEN PARTIAL WALL(S)
ARE PRESENT

NOTES:

- [1] METAL SHAVINGS MUST BE SWEEPED FROM THE WALL EACH DAY DURING ERECTION TO PREVENT SURFACE RUSTING.
- [2] #12 SCREWS ARE USED TO ATTACH THE PANEL TO THE GIRTS. #14 LAP SCREWS ARE USED AT THE PANEL-TO-PANEL ATTACHMENTS. ALL FASTENERS ARE SELF-DRILLING.

ISSUE	DET	CHK	DATE
UNION LaSTEEL			
CUSTOMER: TRAFICANTE			
JOB NO: 8728	DATE: 8/14/24		
LOCATION: LAKE CITY, FL 32025			
DRAWING NAME: SIDEWALL PANEL DETAILS			
DRAWING NO: PAGE 7	DRAWN BY: PS	CHECKED BY: SPW	SCALE: NONE

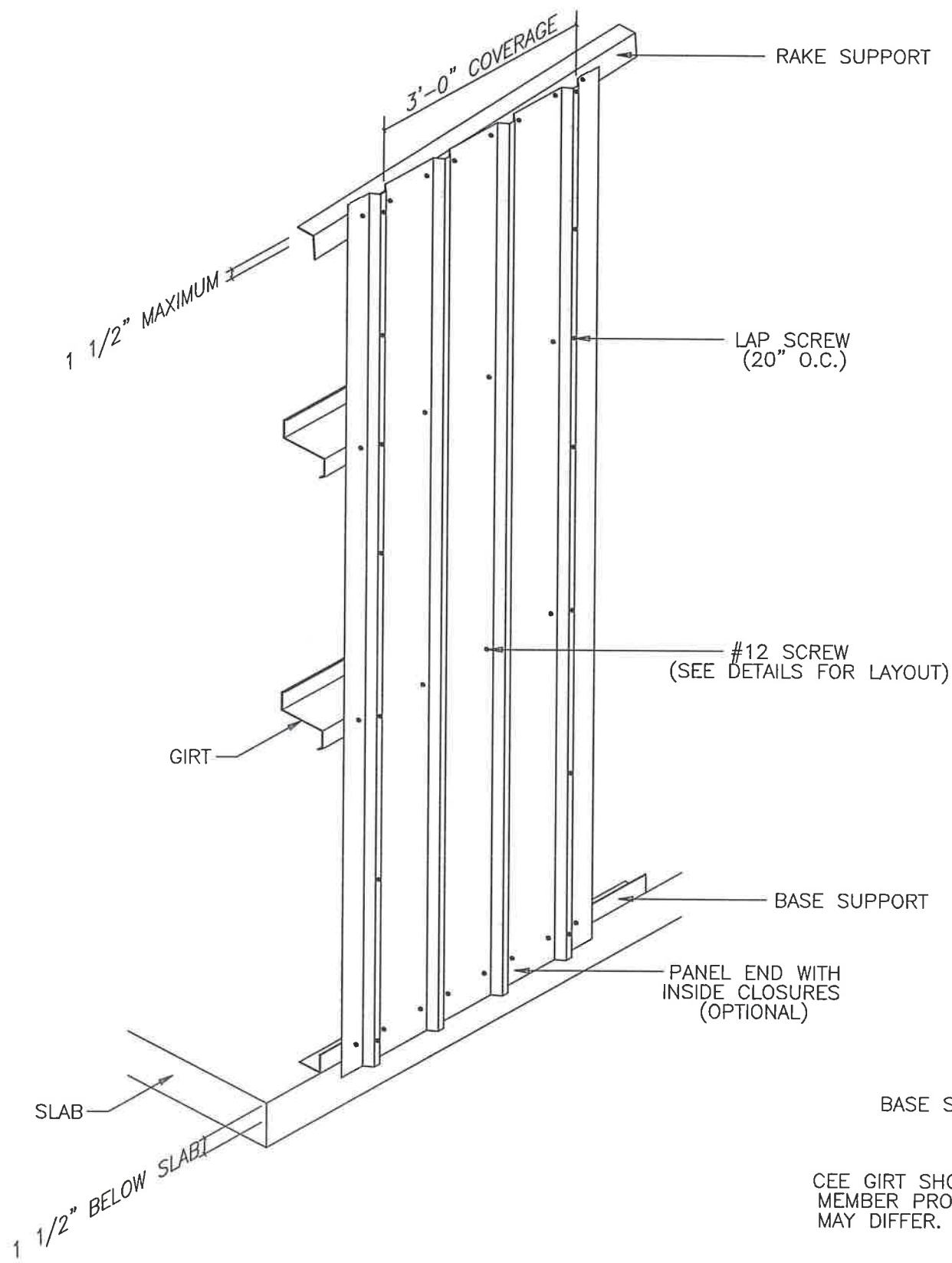

PANEL ATTACHMENT AT PANEL END
 (BASE, EAVE STRUT, HEADER, SILL, AND PANEL END LAPS)

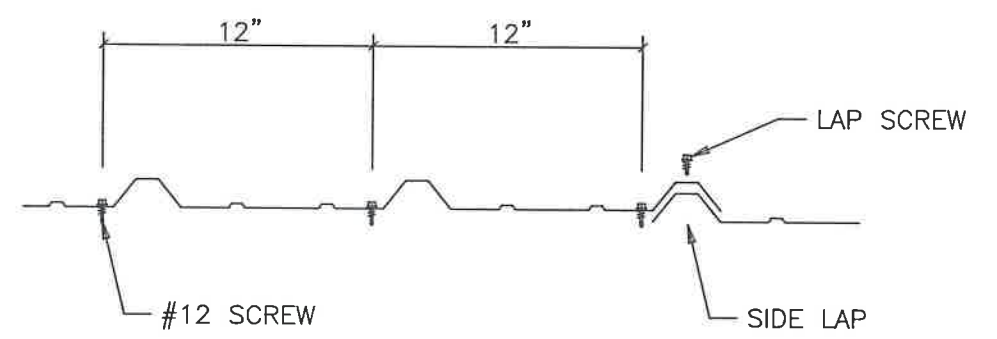
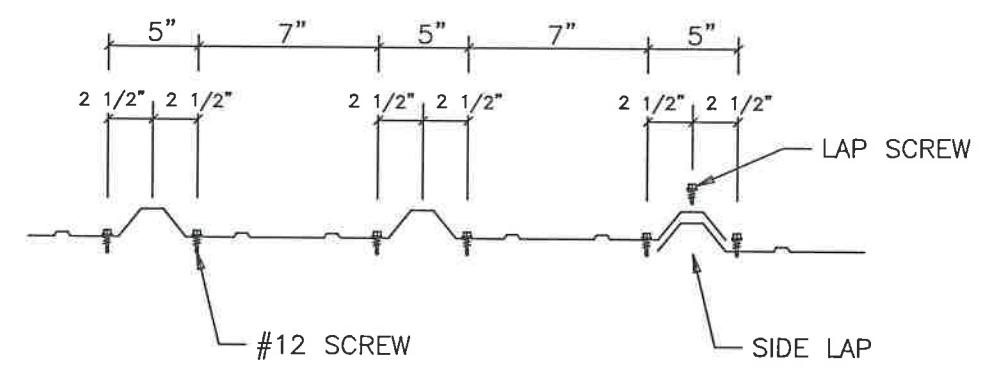

PANEL ATTACHMENT AT INTERMEDIATE MEMBERS

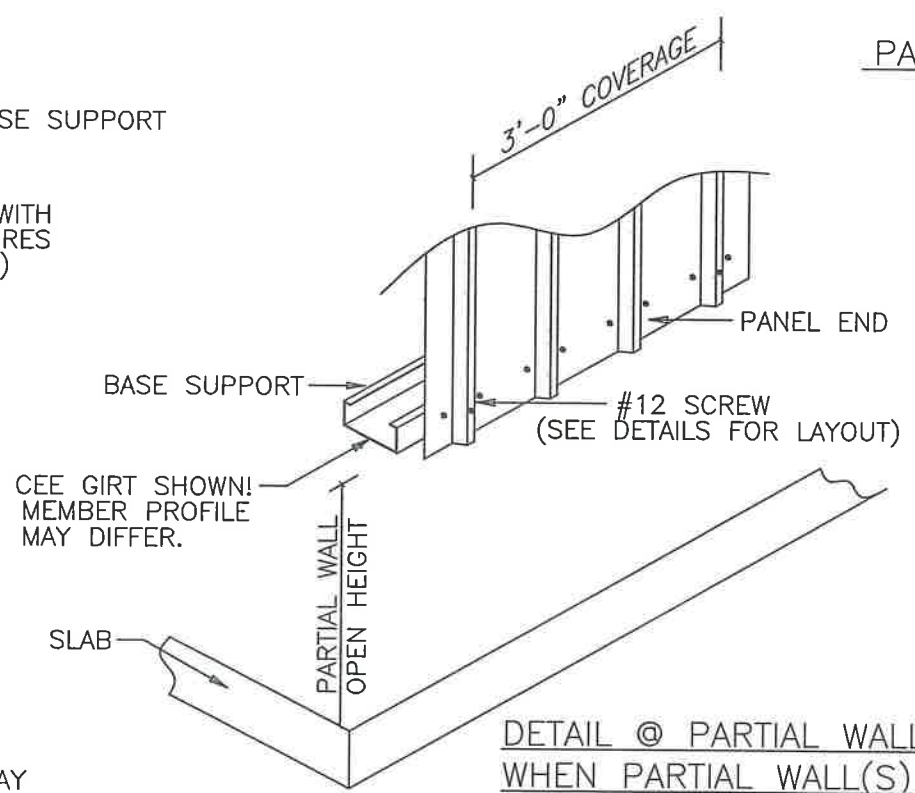

DETAIL @ PARTIAL WALL
WHEN PARTIAL WALL(S)
ARE PRESENT

- NOTES:
- [1] METAL SHAVINGS MUST BE SWEEPED FROM THE WALL EACH DAY DURING ERECTION TO PREVENT SURFACE RUSTING.
 - [2] #12 SCREWS ARE USED TO ATTACH THE PANEL TO THE GIRTS. #14 LAP SCREWS ARE USED AT THE PANEL-TO-PANEL ATTACHMENTS. ALL FASTENERS ARE SELF-DRILLING.

ISSUE	DET	CHK	DATE
UNION LaSTEEL			
CUSTOMER: TRAFICANTE			
JOB NO: 8728	DATE: 8/14/24		
LOCATION: LAKE CITY, FL 32025			
DRAWING NAME: ENDWALL PANEL DETAILS			
DRAWING NO: PAGE 8	DRAWN BY: PS	CHECKED BY: SPW	SCALE: NONE

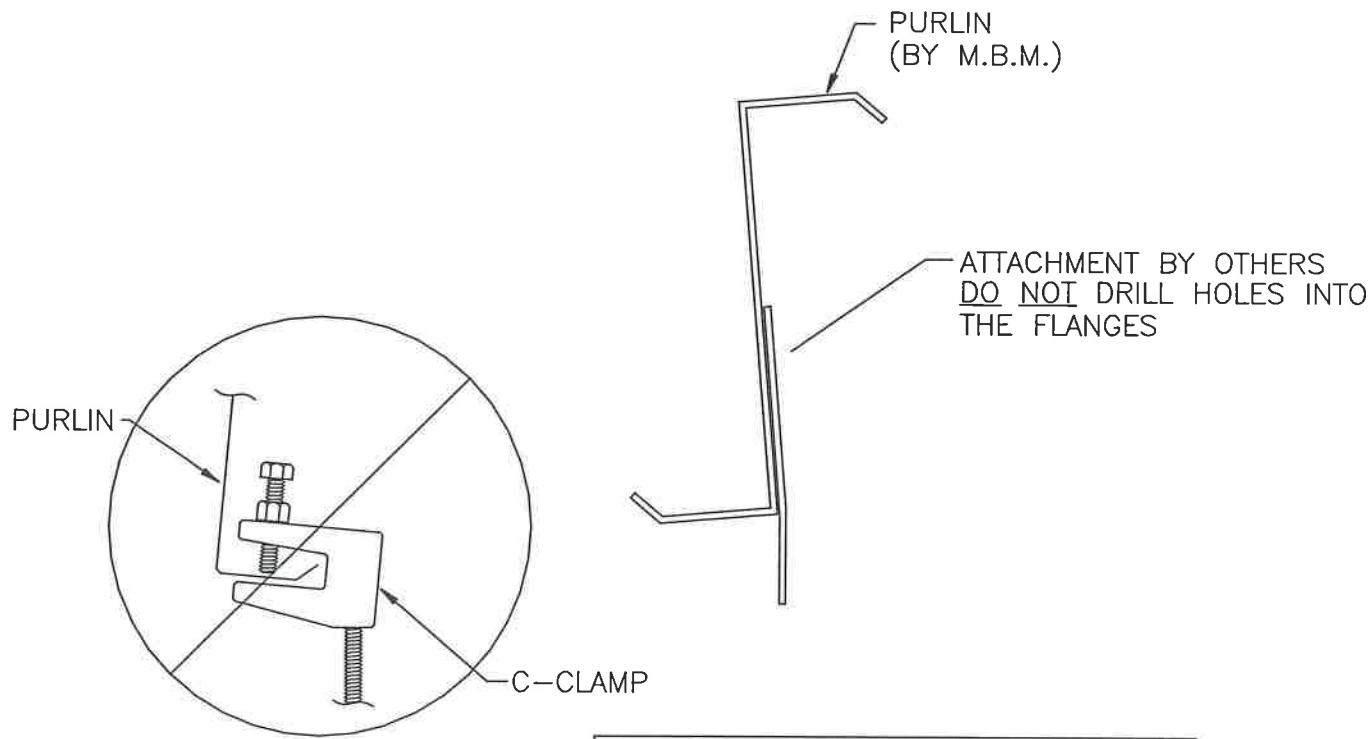

Flange C-Clamp is not an acceptable connection

NOTE: M.B.M. only provides the roof purlin. All other material and hardware is by others.

Recommended Connection Detail

NOTE

MANY FACTORS BEYOND THE CONTROL OF THE METAL BUILDING SUPPLIER AFFECT THE ABILITY OF A PURLIN TO SAFELY SUPPORT HANGING LOADS COMBINED WITH OTHER REQUIRED ROOF LOADS. DUE TO THE VARIABLES INVOLVED IN HANGING LOADS AND THEIR ATTACHMENTS TO THE PURLINS, THE METAL BUILDING SUPPLIER CANNOT ASSURE THAT THE PURLINS FOR A PARTICULAR BUILDING PROJECT CAN SAFELY SUPPORT THE MAXIMUM ALLOWABLE HANGING LOADS IN COMBINATION WITH OTHER ROOF LOADS.

IT IS THE RESPONSIBILITY OF THE HANGER SYSTEM INSTALLER TO COORDINATE WITH THE ENGINEER OF RECORD FOR THE OVERALL PROJECT TO ENSURE A SAFE HANGING LOAD INSTALLATION. THE METAL BUILDING ENGINEER IS NOT THE ENGINEER OF RECORD FOR THE OVERALL PROJECT. WITHOUT SPECIFIC CERTIFICATION FOR INDIVIDUAL HANGING LOADS, THE NET EFFECTS OF APPLIED HANGER LOADS INSTALLED ON A PARTICULAR PURLIN SHALL NOT EXCEED THE NET EFFECTS OF THE CERTIFIED UNIFORMLY APPLIED DESIGN COLLATERAL LOAD.

HANGING LOADS SHOULD NOT BE APPLIED TO THE PURLIN LIP. WHERE PERMISSIBLE, THE BEST PRACTICE FOR HANGING LOADS IS TO ATTACH TO THE PURLIN WEB USING A BOLT AND NUT, OR SELF-DRILLING SCREWS.

HANGING UNIFORM LOADS SUCH AS SPRINKLER MAINS OR HVAC EQUIPMENT SHOULD BE DISTRIBUTED OVER SEVERAL PURLINS, AND SHOULD NEVER EXCEED THE COLLATERAL LOAD ALLOWANCE FOR THE ROOF SYSTEM. FOR UNIFORM LOADS THAT RUN PARALLEL TO THE PURLINS, IT MAY BE NECESSARY TO USE TRANSVERSE SUPPORT CHANNELS(A.K.A. TRAPEZE BEAMS) ATTACHED TO THE WEBS OR FLANGES OF ADJACENT PURLINS TO SPREAD THE LOAD BETWEEN TWO OR MORE PURLINS. IN SUCH CASES, CONTACT THE BUILDING MANUFACTURER OR A LOCAL PROFESSIONAL ENGINEER PRIOR TO ATTEMPTING TO HANG LOADS FROM THE PURLINS

DO NOT INSTALL GUTTER WITH OUTSIDE FACE PERPENDICULAR TO THE GROUND.

INSTALL GUTTER WITH OUTSIDE FACE PERPENDICULAR TO THE ROOF.

GUTTER INSTALLATION DETAIL
(ONLY IF PROVIDED)

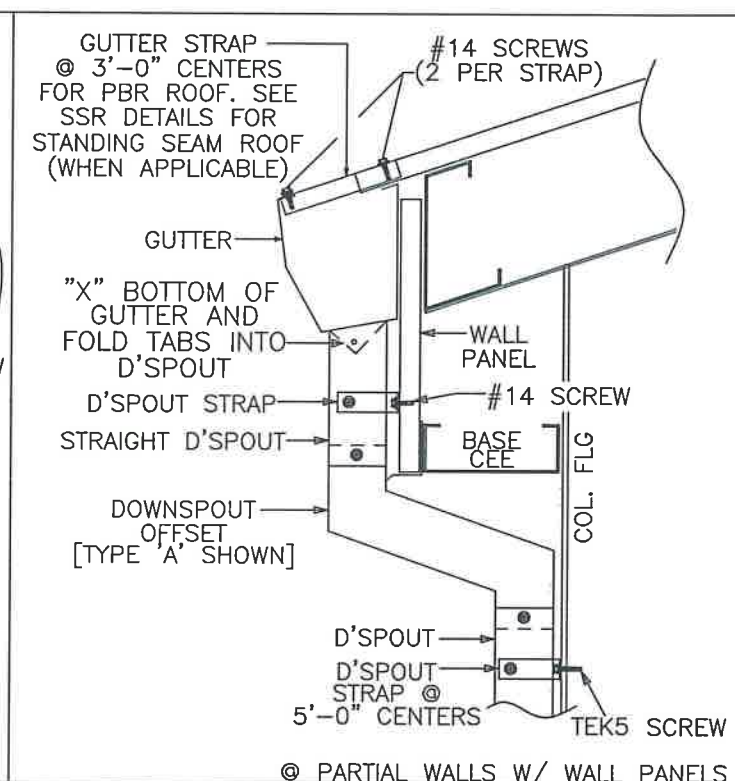
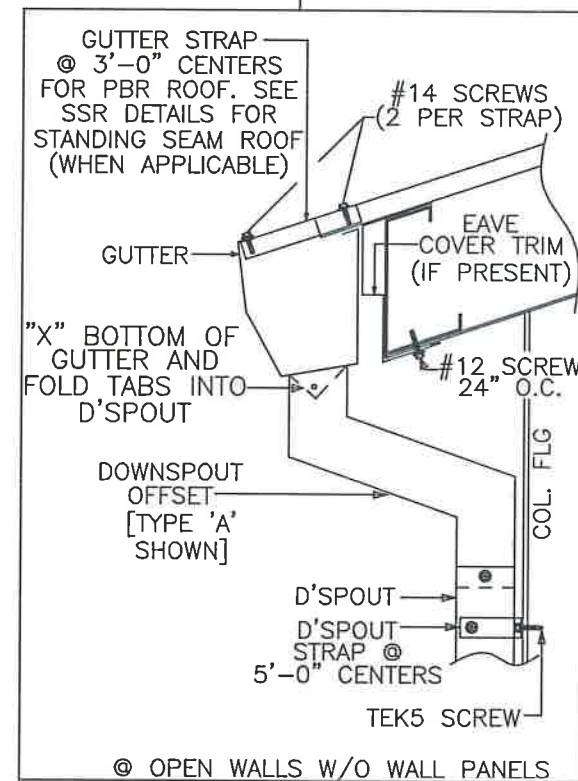

NOTE: REGARDLESS OF DOWNSPOUT OFFSET SCENARIO, TEK5 SCREWS MUST BE USED TO ATTACH DOWNSPOUT STRAPS TO PEMB FRAMING. WHEN WALL PANELS SPAN FROM GROUND TO EAVE (FULL SPAN), #14 SCREWS WILL BE USED TO ATTACH DOWNSPOUT STRAPS TO WALL PANELS.

ISSUE	DET	CHK	DATE
UNION LaSTEEL			
CUSTOMER: TRAFICANTE			
JOB NO: 8728	DATE: 8/14/24		
LOCATION: LAKE CITY, FL 32025			
DRAWING NAME: SPECIAL DETAILS			
DRAWING NO: PAGE 9	DRAWN BY: PS	CHECKED BY: SPW	SCALE: NONE