

# COLUMBIA COUNTY Property Appraiser

## Parcel 16-4S-17-08382-276

### Owners

RETROSSA GREGORY P  
RETROSSA VIVIAN M  
305 SE APACHE WAY  
LAKE CITY, FL 32025

### Parcel Summary

Location	305 SE APACHE WAY
Use Code	0100: SINGLE FAMILY
Tax District	2: COUNTY
Acreage	.4600
Section	16
Township	4S
Range	17
Subdivision	WOODLAND
Exemptions	01: HOMESTEAD (196.031a&b) (100%)

### Legal Description

LOT 6 WOODLAND CENTRAL.

ORB 457-354

### Working Values

	2026
Total Building	\$161,328
Total Extra Features	\$4,072
Total Market Land	\$18,500
Total Ag Land	\$0



//

	2026
Total Market	\$183,900
Total Assessed	\$110,273
Total Exempt	\$51,411
Total Taxable	\$58,862
SOH Diff	\$73,627

## Value History

	2025	2024	2023	2022	2021	2020
Total Building	\$161,328	\$151,239	\$138,285	\$119,551	\$100,830	\$92,186
Total Extra Features	\$4,072	\$4,072	\$4,072	\$4,072	\$4,072	\$4,072
Total Market Land	\$18,500	\$18,500	\$18,500	\$15,000	\$12,400	\$12,372
Total Ag Land	\$0	\$0	\$0	\$0	\$0	\$0
Total Market	\$183,900	\$173,811	\$160,857	\$138,623	\$117,302	\$108,630
Total Assessed	\$107,374	\$104,348	\$101,309	\$98,358	\$95,493	\$94,175
Total Exempt	\$50,722	\$50,000	\$50,000	\$50,000	\$50,000	\$50,000
Total Taxable	\$56,652	\$54,348	\$51,309	\$48,358	\$45,493	\$44,175
SOH Diff	\$76,526	\$69,463	\$59,548	\$40,265	\$21,809	\$14,455

## Document/Transfer/Sales History

Instrument / Official Record	Date	Q/U	Reason	Type	V/I	Sale Price	Ownership
<u>03</u> <u>0457/0352</u>	1980-10-01	<u>Q</u>			Vacant	\$4,150	

## Buildings

### Building # 1, Section # 1, 92186, SFR

Type	Models	Heated Sq Ft	Repl Cost New	YrBlt	Year Eff	Gross Area	Other % Dpr	Normal % Dpr	% Cond	Value
<u>0100</u>	<u>01</u>	1557	\$248,197	1980	1980	2,325	0.00%	35.00%	65.00%	\$161,328

## Structural Elements

Type	Description	Code	Details
EW	Exterior Wall	19	COMMON BRK
RS	Roof Structure	03	GABLE/HIP
RC	Roof Cover	03	COMP SHNGL
IW	Interior Wall	05	DRYWALL

## Sub Areas

Type	Gross Area	Percent of Base	Adjusted Area
<u>BAS</u>	1,557	100%	1,557
<u>FGR</u>	520	55%	286
<u>FOP</u>	88	30%	26
<u>FSP</u>	160	40%	64

Type	Description	Code	Details
IF	Interior Flooring	14	CARPET
IF	Interior Flooring	08	SHT VINYL
AC	Air Conditioning	03	CENTRAL
HT	Heating Type	04	AIR DUCTED
BDR	Bedrooms	3.00	
BTH	Bathrooms	2.00	
FR	Frame	01	NONE
STR	Stories	1.	1.
AR	Architectural Type	05	CONV
COND	Condition Adjustment	03	03
KTCH	Kitchen Adjustment	01	01

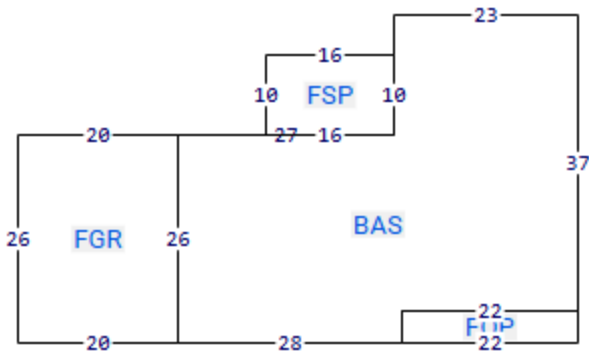

## Extra Features

Code	Description	Length	Width	Units	Unit Price	AYB	% Good Condition	Final Value
0166	CONC,PAVMT			1.00	\$0.00	0	100%	\$600
0190	FPLC PF			1.00	\$1,200.00	0	100%	\$1,200
0210	GARAGE U	16	26	416.00	\$4.50	1998	100%	\$1,872
0120	CLFENCE 4			1.00	\$0.00	2013	100%	\$400

## Land Lines

Code	Description	Zone	Front	Depth	Units	Rate/Unit	Acreage	Total Adj	Value
0100	SFR	A-1	.00	.00	1.00	\$18,500.00/LT	0.46	1.00	\$18,500

## Personal Property

None

## Permits

None

## TRIM Notices

2025

2024

2023

## Disclaimer

All parcel data on this page is for use by the Columbia County Assessor for assessment purposes only. The summary data on this page may not be a complete representation of the parcel or of the improvements thereon. Building information, including unit counts and number of permitted units, should be verified with the appropriate building and planning agencies. Zoning information should be verified with the appropriate planning agency. All parcels are reappraised each year. This is a true and accurate copy of the records of the Columbia County Assessor's Office as of March 23, 2026.