



FBC APPROVED PRODUCT LIST

CATEGORY	SUBCATEGORY	MANUFACTURER & PRODUCT	APPROVAL NUMBER	MAX ALLOWABLE WINDSPEED (MPH)
STRUCTURAL COMPONENT	ROOF DECK	CARPORTS ANYWHERE, HAMPTON RIB ROOF PANEL	27402.1-R1	180
STRUCTURAL COMPONENT	STRUCTURAL WALL	CARPORTS ANYWHERE, HAMPTON RIB WALL PANEL	27403.1	180
STRUCTURAL COMPONENT	STRUCTURAL WALL	CARPORTS ANYWHERE, RESI-LAP SIDING WALL PANEL	27403.2	180
PANEL WALLS	WALL LOUVER (FLOOD VENT)	FLOOD SOLUTIONS, LLC., FS & FS HEX	17588.1	N/A
EXTERIOR DOOR	SWINGING	ELIXER DOOR & METAL CO., SERIES 230 W9 STEEL O.S DOOR W/ COTTAGE WINDOW	17996.2	180
EXTERIOR DOOR	SWINGING	ELIXER DOOR & METAL CO., SERIES 407 VINYL STEEL OUT-SWINGING REGULAR DOOR - BLANK (NO WINDOW)	17996.5	180
EXTERIOR DOOR	SWINGING	THERMA-TRU CORPORATION, "CONSTRUCTION SERIES" AND "BENCHMARK BY THERMA-TRU"	15225.2	180
EXTERIOR DOOR	ROLL-UP	ASTA DOOR CORPORATION, 203 WINDLOCK	8888.1	150
EXTERIOR DOOR	ROLL-UP	JANUS INTERNATIONAL GROUP, LLC., SERIES 3100: +40/-40	21450.3	180
EXTERIOR DOOR	ROLL-UP	JANUS INTERNATIONAL GROUP, LLC., SERIES 3100: +42.5/-45	21450.4	180
EXTERIOR DOOR	ROLL-UP	JANUS INTERNATIONAL GROUP, LLC., SERIES 750: MAX 8'x12' +24.4/-27	21450.9	160
EXTERIOR DOOR	ROLL-UP	JANUS INTERNATIONAL GROUP, LLC., SERIES 750: MAX 10'x12' +19.4/-22.7	21450.10	140
WINDOW	SINGLE HUNG	POCAHONTAS ALUMINUM COMPANY, INC., 100 VS VERTICAL SLIDING WINDOW	12940.1	150
WINDOW	SINGLE HUNG	MI WINDOWS AND DOORS, 185 SH	17499.1-R5	180

POST/TRUSS MAXIMUM SPACINGS

ULTIMATE WINDSPEED (MPH)	STRUCTURE WIDTH (FT)	MAXIMUM POST/TRUSS SPACING (FT)
120-150	6-24	5.0
120-150	>24-30	4.0
>150	ALL	4.0

NOTES:
 1. NOT APPLICABLE FOR STRUCTURES WITH A MEAN ROOF HEIGHT OVER 20 FEET AND/OR ROOF PITCH STEEPER THAN 6:12
 2. APPLICABLE ONLY FOR ANY MATERIALS LISTED ON THE APPROVED PRODUCTS CHART AND FRAMING INDICATED IN THE GENERAL NOTES AND DETAILS
 3. 5" O.C. REQUIRES VERTICAL ROOF.

GROUND ANCHOR LENGTH

SOIL TYPE	WIND SPEED (MPH)			
	≤ 140	145-155	160-170	175-180
VERY DENSE AND/OR CEMENTED SAND, COARSE GRAVEL, COBBLES, PRELOADED SILTS, CLAYS AND CORAL	30"	30"	48"	48"
MEDIUM DENSE COARSE SANDS, SANDY GRAVEL, VERY STIFF SILTS AND CLAYS	30"	48"	48"	60"
LOOSE TO MEDIUM DENSE SANDS, FIRM TO STIFF CLAYS, SILTS AND ALLUVIAL FILL	48"	48"	60"	60"
LOOSE SANDS, FIRM CLAYS, SILTS AND ALLUVIAL FILL	48"	60"	60"	60"

NOTES:

SUB-GRADE SOILS:

-TO BE TERMITE TREATED AND COVERED WITH 6 MIL VAPOR RETARDANT PER SECTION R318 AND 1816 OF THE 2020 FLORIDA BUILDING CODE, 7TH EDITION

CONCRETE:

-MINIMUM 2,500 PSI COMPRESSIVE STRENGTH AT 28 DAYS

-ALL OPEN AREAS OF CONCRETE OUTSIDE OF THE PROPOSED STRUCTURE SHALL BE DESIGNED TO SLOPE AWAY FROM THE STRUCTURE

REINFORCING STEEL (REBAR) REQUIREMENTS:

-MINIMUM GRADE 40 STEEL

-REBAR MAY BE BENT IN SHOP OR FIELD PROVIDED:

-THE REBAR IS BENT COLD

-THE DIAMETER OF THE BEND MEASURED ON THE INSIDE DOES NOT EXCEED 6-BAR DIAMETERS: AND

-REINFORCEMENT PARTIALLY EMBEDDED IN CONCRETE SHALL NOT BE FIELD BENT EXCEPT IN CASES WHERE DOWELS NEED TO BE BENT TO ALIGN WITH A VERTICAL CELL. THESE REBAR MAY BE BENT NOT TO EXCEED TO SLOPE OF 1" HORIZONTALLY TO 6" VERTICALLY.

-COVER:

-3" COVER MINIMUM WHERE THE CONCRETE IS CAST AGAINST AND PERMANENTLY IN CONTACT WITH SOIL OR WEATHER, AND 1 1/2" ELSEWHERE. REBAR EMBEDDED IN GROUTED CELLS SHALL HAVE A MINIMUM CLEAR DISTANCE OF 1/4" FOR FINE GROUT, AND 1/2" FOR COARSE GROUT BETWEEN REBAR AND ANY FACE OF A CELL. REBAR USED IN MASONRY WALLS SHALL HAVE A MASONRY COVER (INCLUDING GROUT) OF NOT LESS THAN 2" FOR MASONRY UNITS WITH FACE EXPOSED TO EARTH OR WEATHER, AND 1 1/2" FOR MASONRY UNITS NOT EXPOSED TO EARTH OR WEATHER.

GALVANIZATION:

-METAL ACCESSORIES FOR USE IN EXTERIOR WALL CONSTRUCTION AND NOT DIRECTLY EXPOSED TO WEATHER SHALL BE GALVANIZED IN ACCORDANCE WITH ASTM A 153, CLASS B-2. METAL PLATE CONNECTORS, SCREWS, BOLTS, AND NAILS EXPOSED DIRECTLY TO WEATHER SHALL BE STAINLESS STEEL OR HOT DIPPED GALVANIZED.

THESE PLANS PERTAIN ONLY TO THE STRUCTURE, INCLUDING MAIN WIND FORCE RESISTING SYSTEM, COMPONENTS AND CLADDING, AND BASE RAIL ANCHORAGE. OTHER DESIGN ISSUES, INCLUDING BUT NOT LIMITED TO PLUMBING, ELECTRICAL, INGRESS/EGRESS, PROPERTY SET-BACKS, FINISH FLOOR ELEVATION AND SLOPE, OR OTHER LOCAL ZONING REQUIREMENTS ARE THE RESPONSIBILITY OF OTHERS.

THESE STRUCTURES ARE DESIGNED AS NON-HABITABLE UTILITY/STORAGE BUILDINGS (RISK CATEGORY I) CAPABLE OF SUPPORTING DEAD LOAD OF THE STRUCTURE AND APPLICABLE LIVE AND WIND LOADS. IMPROVEMENTS NOT SPECIFICALLY ADDRESSED HEREIN, INCLUDING DOORS, WINDOWS, OR OTHER COMPONENTS NOT LISTED IN THE FBC APPROVED PRODUCTS LIST (THIS SHEET), AND NOT PROVIDED AND INSTALLED BY CARPORTS ANYWHERE, INC., WHICH EXERT ADDITIONAL LOADS ON THE STRUCTURE SHALL BE AT THE OWNER'S RISK. CARPORTS ANYWHERE NOR THE ENGINEERING DESIGN SHALL NOT BE RESPONSIBLE FOR STRUCTURAL DAMAGE OR FAILURE DUE TO THE APPLICATION OF ADDITIONAL LOADS.

BASE RAIL GROUND ANCHOR REQUIREMENTS: ONE WITHIN 6" OF EVERY POST LOCATION, AND BOTH SIDES OF OPENINGS WHERE BASE RAIL IS ABSENT. GROUND ANCHORS ARE NOT REQUIRED FOR CONCRETE FOOTING AND/OR CONCRETE SLAB CONSTRUCTION. SEE GROUND ANCHOR SCHEDULE (THIS SHEET) FOR SPECIFIC TYPE GROUND ANCHOR REQUIREMENTS.



PRINTED COPIES OF THIS DOCUMENT ARE NOT CONSIDERED SIGNED AND SEALED AND THE SHA AUTHENTICATION CODE MUST BE VERIFIED ON ANY ELECTRONIC COPIES

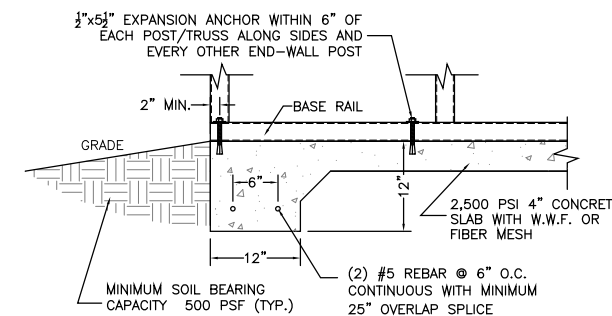

CONCRETE FOUNDATION/BASE RAIL ANCHOR DETAIL

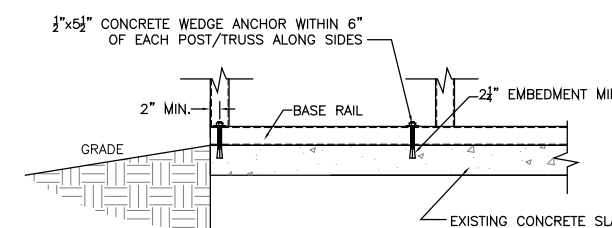

CONCRETE FOUNDATION/BASE RAIL ANCHOR DETAIL (OPEN ONLY)

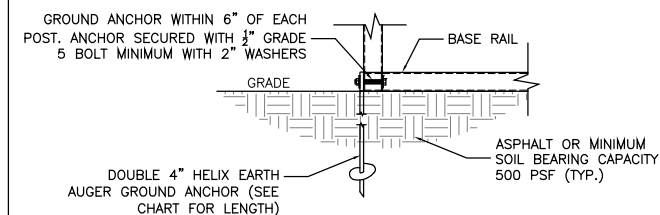

GROUND ANCHOR BASE RAIL DETAIL

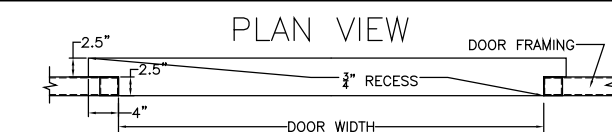

OPTIONAL ROLL-UP DOOR CONCRETE SPLASH-GUARD RECESS

CODE INFORMATION

CODE VERSION	FBC 2020 7th Edition, ASCE-7-16
MANUFACTURER	CARPORTS ANYWHERE
BUILDING TYPE	UTILITY STRUCTURE
CONSTRUCTION TYPE	II-B
RISK CATEGORY	1
FIRE PROTECTION	NONE
FIRE SUPPRESSION SYSTEM	NONE
OCCUPANCY	UTILITY U
BASIC WIND SPEED	Vac: 120-180mph
EXPOSURE	B/C
ENCLOSURE	ENCLOSED
INTERNAL PRESSURE COEFFICIENT	+/- 0.18
IMPORTANCE FACTOR	1.0
ROOF DEAD LOAD	10PSF
ROOF LIVE LOAD	20PSF OR 300lb POINT LOAD
FLOOR DEAD LOAD	10PSF
FLOOR LIVE LOAD	50PSF
"R" RATING OF WALLS, FLOOR, ROOF	N/A
MODULES PER BUILDING	1
HURRICANE PROTECTION USAGE	NO
HURRICANE SHELTER USAGE	NO
SQUARE FOOTAGE	

REVISIONS

REV	DESCRIPTION	DATE	BY

Drawn By:	MTB
Date:	5/27/20
Location:	FLORIDA
Model#:	ENCLOSED GENERIC ENGINEERING

GENERAL NOTES
 1. THIS BUILDING IS EXEMPT FROM THE FBC ENERGY CONSERVATION CODE PER SECTION C101.4.2.
 2. ALL STEEL TUBING SHALL BE 50 KSI STEEL.
 3. PLUMBING, ELECTRICAL, INGRESS/EGRESS, PROPERTY SET-BACKS, AND/OR OTHER LOCAL CODE REQUIREMENTS ARE THE RESPONSIBILITY OF THE OWNER.
 4. ROOF AND WALL SHEATHING SECURED WITH #12-14x1" SELF-DRILLING SCREWS WITH SEAL WASHERS @ 6" O.C. MAX.
 5. FIELD FRAMING CONNECTIONS SECURED WITH #12-14x3/4" SELF-DRILLING SCREWS.
 6. ALL SHOP FRAMING CONNECTIONS ARE TO BE WELDED. NO WELDING ONSITE. ALL WELDING DONE IN SHOP BY A CERTIFIED WELDER.
 7. CONCRETE EXPANSION ANCHORS ARE TO BE MINIMUM 1/2"x3", 2,500LB TENSILE STRENGTH.
 8. 12 OR 14GA. FRAMING IS 2.5"x2.5" TUBE STEEL. NIPPLES ARE 2.25"x2.25" TUBE STEEL.

TITLE: PRODUCTS, ANCHORING, SPACING & CONCRETE DETAILS

Matthew T. Baldwin P.E.
 Florida License #64608

Sheet: CA-1 OF 3

PRINTED COPIES OF THIS DOCUMENT ARE NOT CONSIDERED SIGNED AND SEALED AND THE SHA AUTHENTICATION CODE MUST BE VERIFIED ON ANY ELECTRONIC COPIES

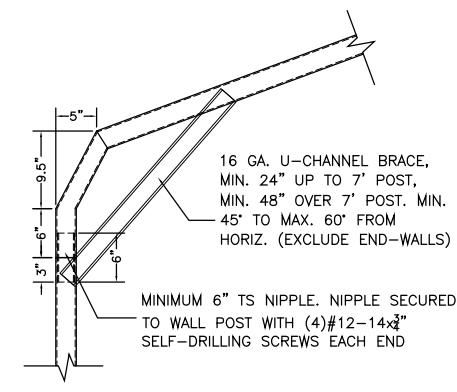

BOW RAFTER TO POST CONNECTION DETAIL

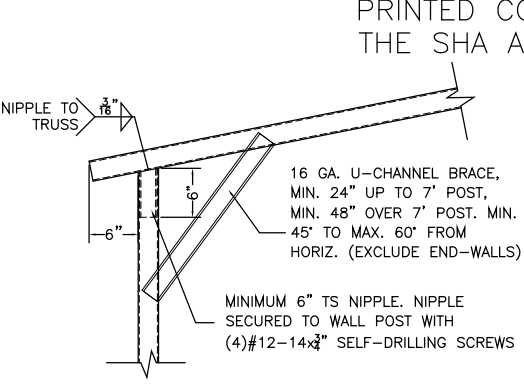

BOX EAVE RAFTER TO POST CONNECTION DETAIL

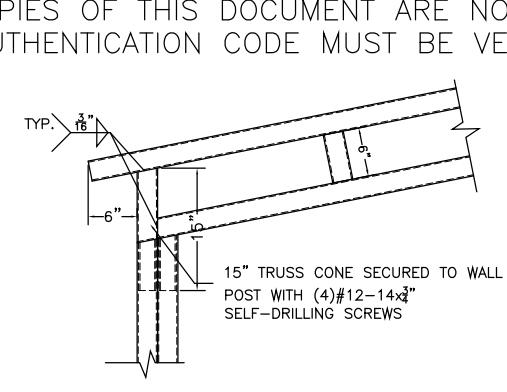

40' BOX EAVE RAFTER TO POST CONNECTION DETAIL

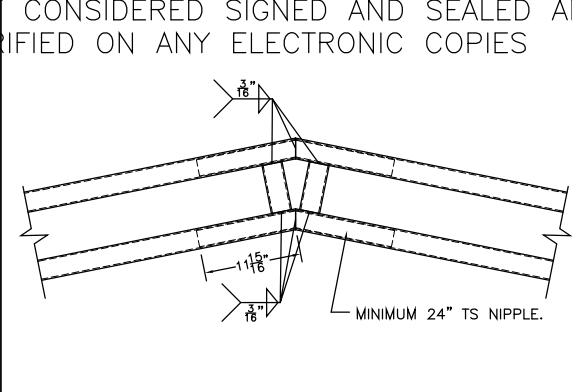

TRUSSED RAFTER CONNECTION DETAIL

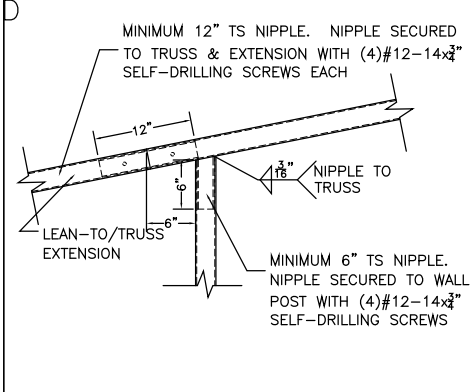

LEAN-TO TO TRUSS CONNECTION

CODE INFORMATION	
CODE VERSION	FBC 2020 7th Edition, ASCE-7-16
MANUFACTURER	CARPORTS ANYWHERE
BUILDING TYPE	UTILITY STRUCTURE
CONSTRUCTION TYPE	II-B
RISK CATEGORY	1
FIRE PROTECTION	NONE
FIRE SUPPRESSION SYSTEM	NONE
OCCUPANCY	UTILITY U
BASIC WIND SPEED	Var: 120-180mph
EXPOSURE	B/C
ENCLOSURE	ENCLOSED
INTERNAL PRESSURE COEFFICIENT	+/- 0.18
IMPORTANCE FACTOR	1.0
ROOF DEAD LOAD	10PSF
ROOF LIVE LOAD	20PSF OR 300lb POINT LOAD
FLOOR DEAD LOAD	10PSF
FLOOR LIVE LOAD	50PSF
"R" RATING OF WALLS, FLOOR, ROOF	N/A
MODULES PER BUILDING	1
HURRICANE PROTECTION USAGE	NO
HURRICANE SHELTER USAGE	NO
SQUARE FOOTAGE	

REVISIONS			
REV	DESCRIPTION	DATE	BY

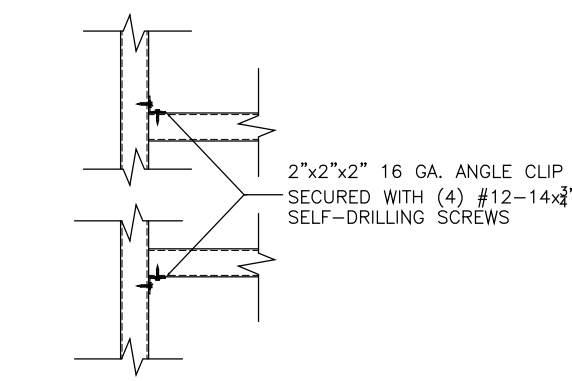

NON-STRUCTURAL HEADER OR WINDOW RAIL TO POST DETAIL

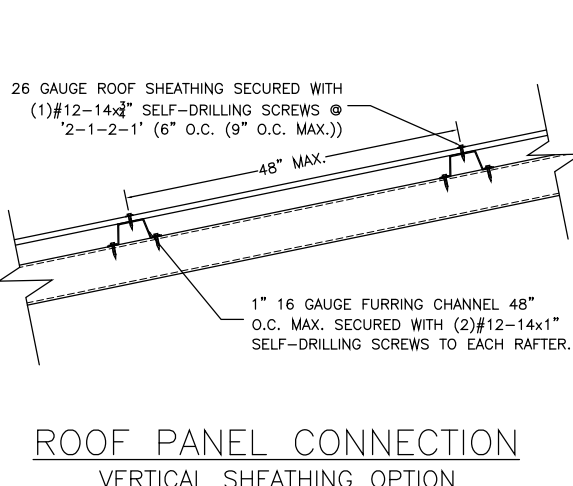
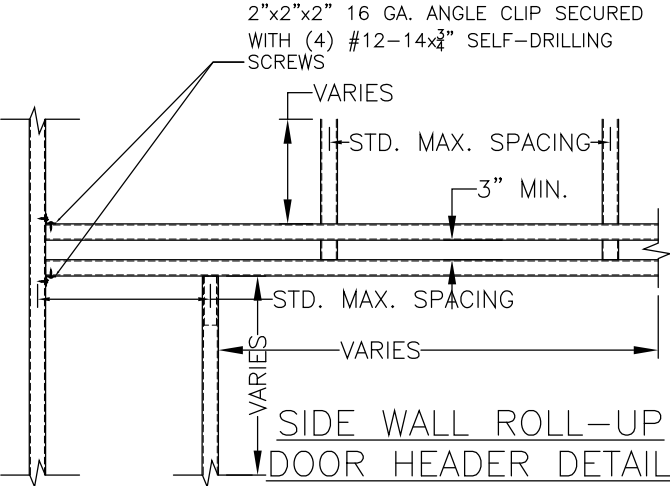

ROOF PANEL CONNECTION VERTICAL SHEATHING OPTION

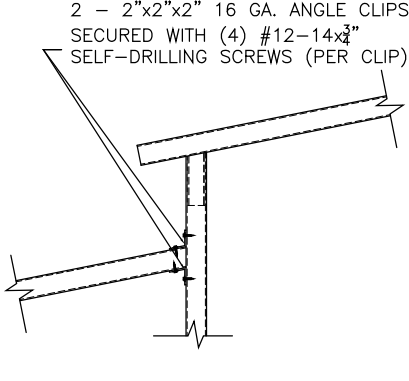

LEAN-TO TO TRUSS CONNECTION

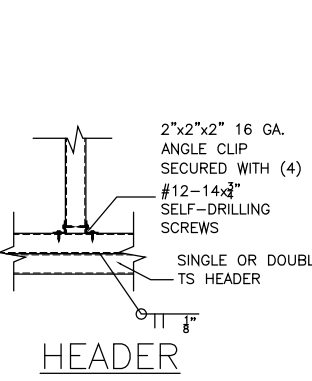

HEADER CONNECTION DETAIL OPTION 1

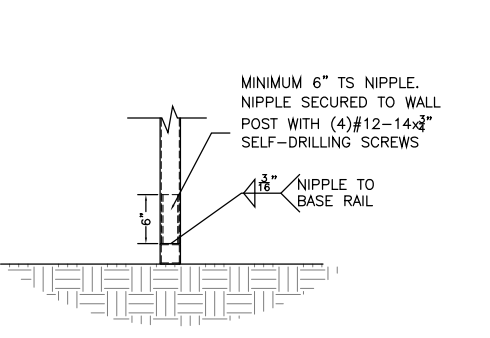

POST TO BASE RAIL CONNECTION

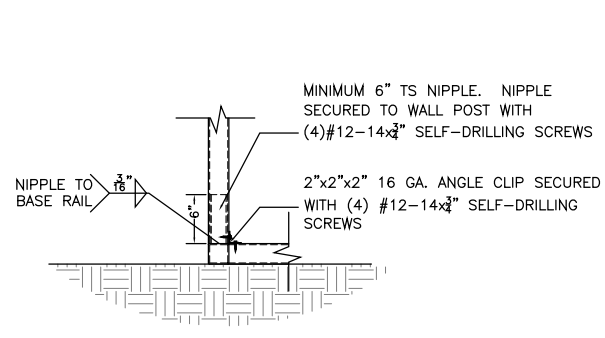

END POST TO BASE RAIL CONNECTION

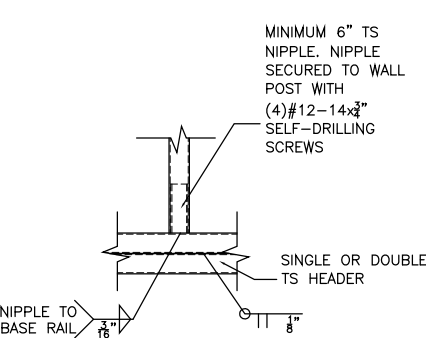

HEADER CONNECTION DETAIL OPTION 2

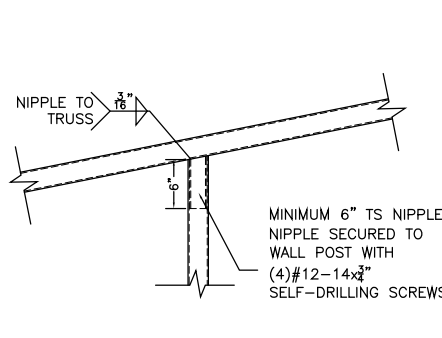

POST TO TRUSS CONNECTION

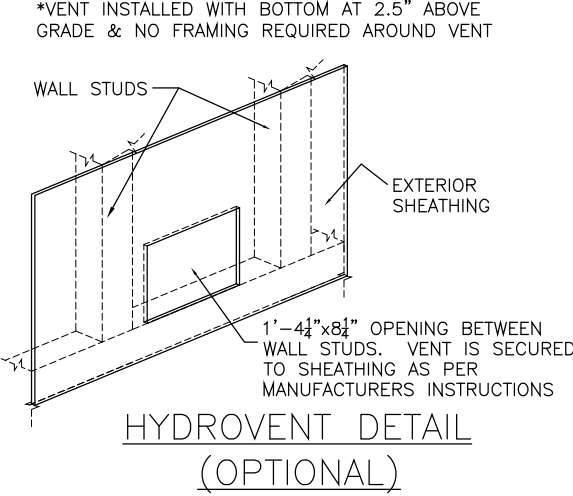

HYDROVENT DETAIL (OPTIONAL)

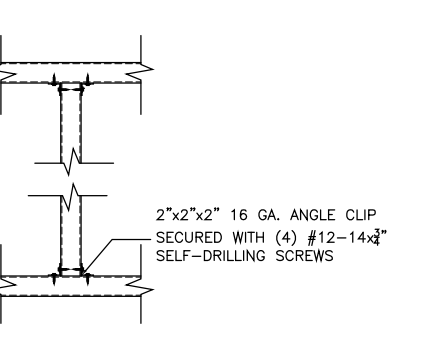

INTERMEDIATE POST TO HEADER/BASE RAIL/OR WINDOW RAIL DETAIL

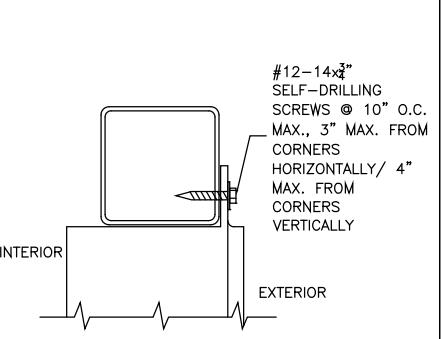

DOOR FRAME TO POST CONNECTION

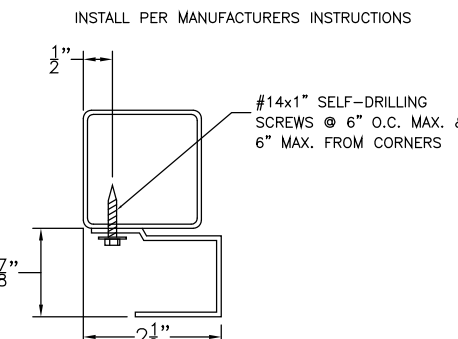

ROLL-UP DOOR TO POST CONNECTION

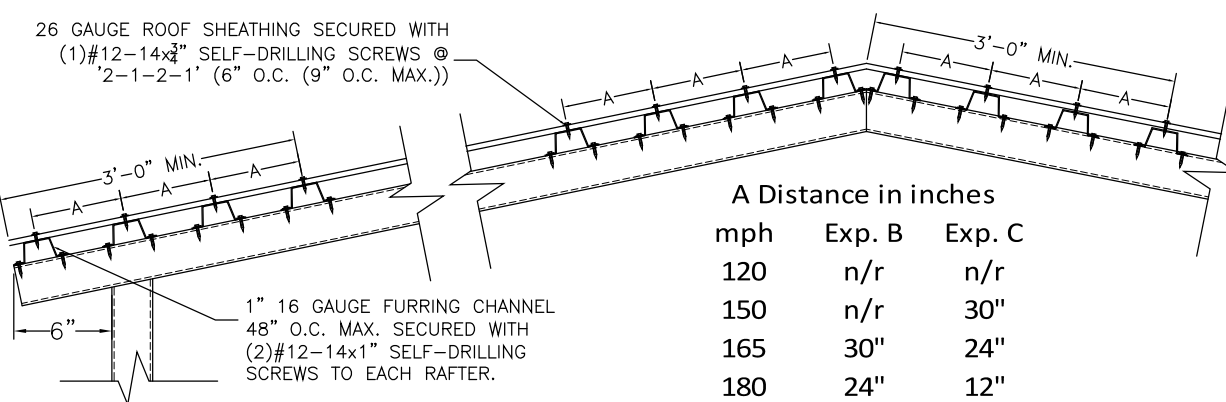

EAVE & RIDGE REINFORCED ROOF PANEL CONNECTION (RIDGE 3r AND EAVE 3e)

A Distance in inches	mph	Exp. B	Exp. C
	120	n/r	n/r
	150	n/r	30"
	165	30"	24"
	180	24"	12"

Drawn By: MTB
 Date: 5/27/20
 Location: FLORIDA
 Model#: ENCLOSED GENERIC ENGINEERING

GENERAL NOTES

- THIS BUILDING IS EXEMPT FROM THE FBC ENERGY CONSERVATION CODE PER SECTION C101.4.2.
- ALL STEEL TUBING SHALL BE 50 KSI STEEL.
- PLUMBING, ELECTRICAL, INGRESS/EGRESS, PROPERTY SET-BACKS, AND/OR OTHER LOCAL CODE REQUIREMENTS ARE THE RESPONSIBILITY OF THE OWNER.
- ROOF AND WALL SHEATHING SECURED WITH #12-14x1" SELF-DRILLING SCREWS WITH SEAL WASHERS @ 6" O.C. MAX.
- FIELD FRAMING CONNECTIONS SECURED WITH #12-14x3/4" SELF-DRILLING SCREWS.
- ALL SHOP FRAMING CONNECTIONS ARE TO BE WELDED. NO WELDING ON-SITE. ALL WELDING DONE IN SHOP BY A CERTIFIED WELDER.
- CONCRETE EXPANSIONS ANCHORS ARE TO BE MINIMUM 1/2"x3", 2,500LB TENSILE STRENGTH.
- 12 OR 14GA. FRAMING IS 2.5"x2.5" TUBE STEEL. NIPPLES ARE 2.25"x2.25" TUBE STEEL.

TITLE: DETAILS



CODE INFORMATION

CODE VERSION	FBC 2020 7th Edition, ASCE-7-16
MANUFACTURER	CARPORTS ANYWHERE
BUILDING TYPE	UTILITY STRUCTURE
CONSTRUCTION TYPE	II-B
RISK CATEGORY	1
FIRE PROTECTION	NONE
FIRE SUPPRESSION SYSTEM	NONE
OCCUPANCY	UTILITY U
BASIC WIND SPEED	Var: 120-180mph
EXPOSURE	B/C
ENCLOSURE	ENCLOSED
INTERNAL PRESSURE COEFFICIENT	+/- 0.18
IMPORTANCE FACTOR	1.0
ROOF DEAD LOAD	10PSF
ROOF LIVE LOAD	20PSF OR 300lb POINT LOAD
FLOOR DEAD LOAD	10PSF
FLOOR LIVE LOAD	50PSF
"R" RATING OF WALLS, FLOOR, ROOF	N/A
MODULES PER BUILDING	1
HURRICANE PROTECTION USAGE	NO
HURRICANE SHELTER USAGE	NO
SQUARE FOOTAGE	

REVISIONS

REV	DESCRIPTION	DATE	BY

Drawn By:	MTB
Date:	5/27/20
Location:	FLORIDA
Model#:	ENCLOSED GENERIC ENGINEERING

- GENERAL NOTES**
- THIS BUILDING IS EXEMPT FROM THE FBC ENERGY CONSERVATION CODE PER SECTION C101.4.2.
 - ALL STEEL TUBING SHALL BE 50 KSI STEEL.
 - PLUMBING, ELECTRICAL, INGRESS/EGRESS, PROPERTY SET-BACKS, AND/OR OTHER LOCAL CODE REQUIREMENTS ARE THE RESPONSIBILITY OF THE OWNER.
 - ROOF AND WALL SHEATHING SECURED WITH #12-14x1" SELF-DRILLING SCREWS WITH SEAL WASHERS @ 6" O.C. MAX.
 - FIELD FRAMING CONNECTIONS SECURED WITH #12-14x3/4" SELF-DRILLING SCREWS.
 - ALL SHOP FRAMING CONNECTIONS ARE TO BE WELDED. NO WELDING ONSITE. ALL WELDING DONE IN SHOP BY A CERTIFIED WELDER.
 - CONCRETE EXPANSIONS ANCHORS ARE TO BE MINIMUM 1/2"x3", 2,500LB TENSILE STRENGTH.
 - 12 OR 14GA. FRAMING IS 2.5"x2.5" TUBE STEEL. NIPPLES ARE 2.25"x2.25" TUBE STEEL.

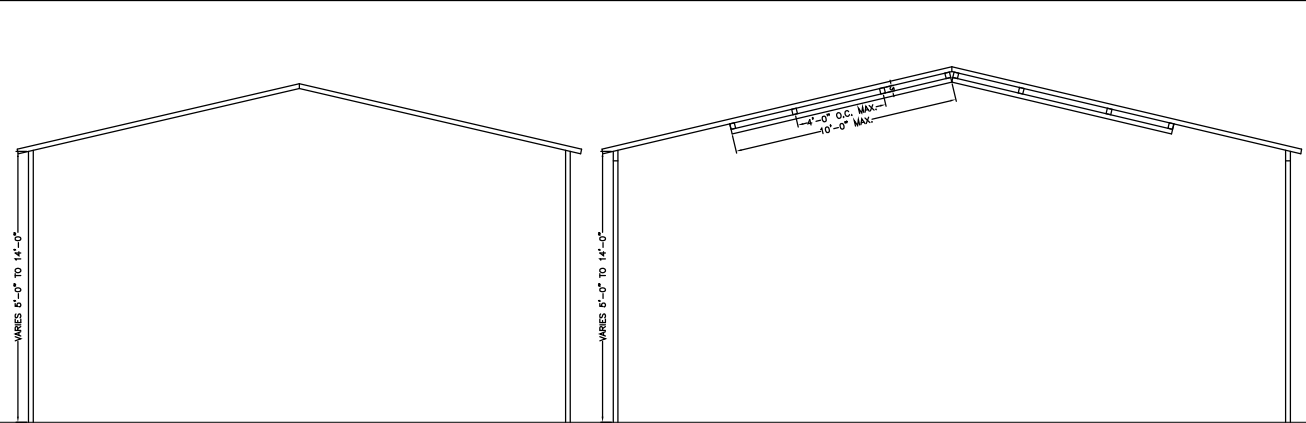

TYPICAL POST/TRUSS FRAMING SECTION - BOX EAVE, UP TO & INCLUDING 24' WIDE

TYPICAL POST/TRUSS FRAMING SECTION - BOX EAVE, 24'-1" TO 30' WIDE

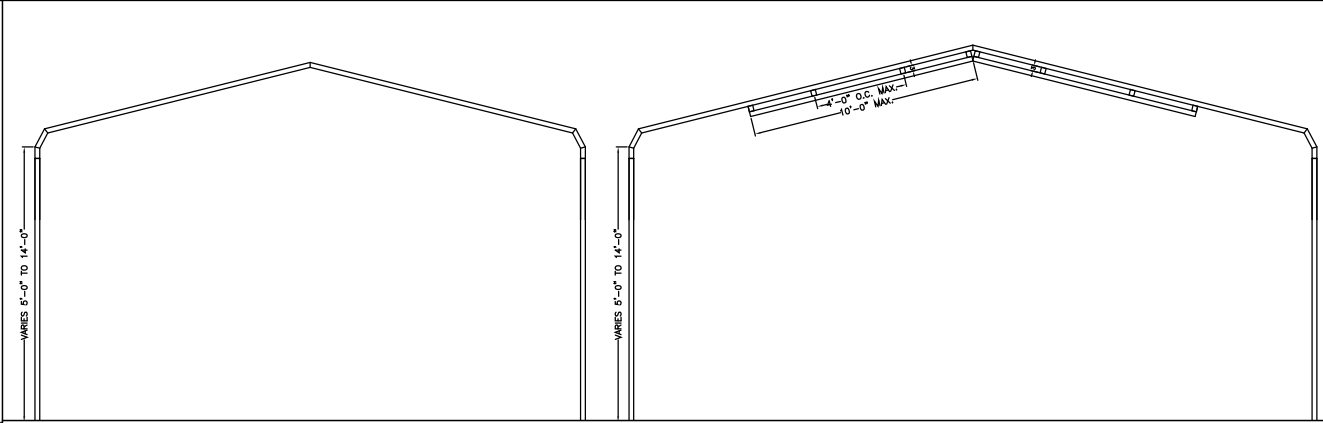

PRINTED COPIES OF THIS DOCUMENT ARE NOT CONSIDERED SIGNED AND SEALED AND THE SHA AUTHENTICATION CODE MUST BE VERIFIED ON ANY ELECTRONIC COPIES

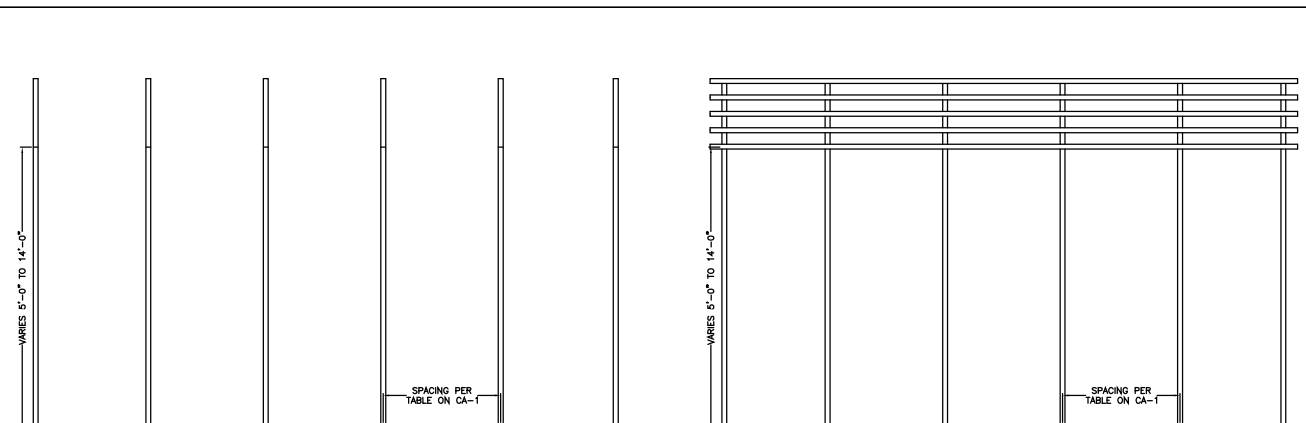

TYPICAL SIDE WALL FRAMING - BOX EAVE/BOW FRAME, HORIZONTAL ROOF

TYPICAL SIDE WALL FRAMING - BOX EAVE, VERTICAL ROOF

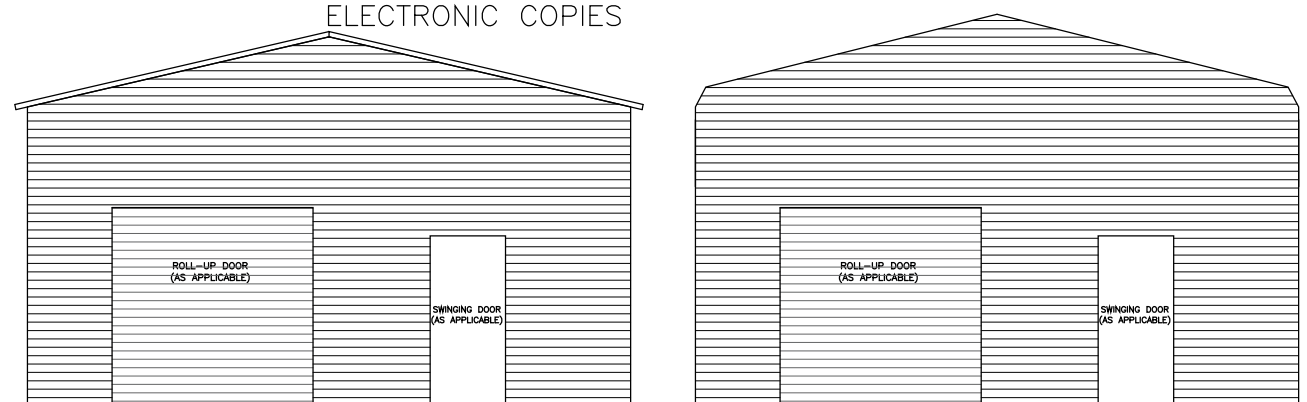

ROLL-UP DOOR (AS APPLICABLE)

SWINGING DOOR (AS APPLICABLE)

ROLL-UP DOOR (AS APPLICABLE)

SWINGING DOOR (AS APPLICABLE)

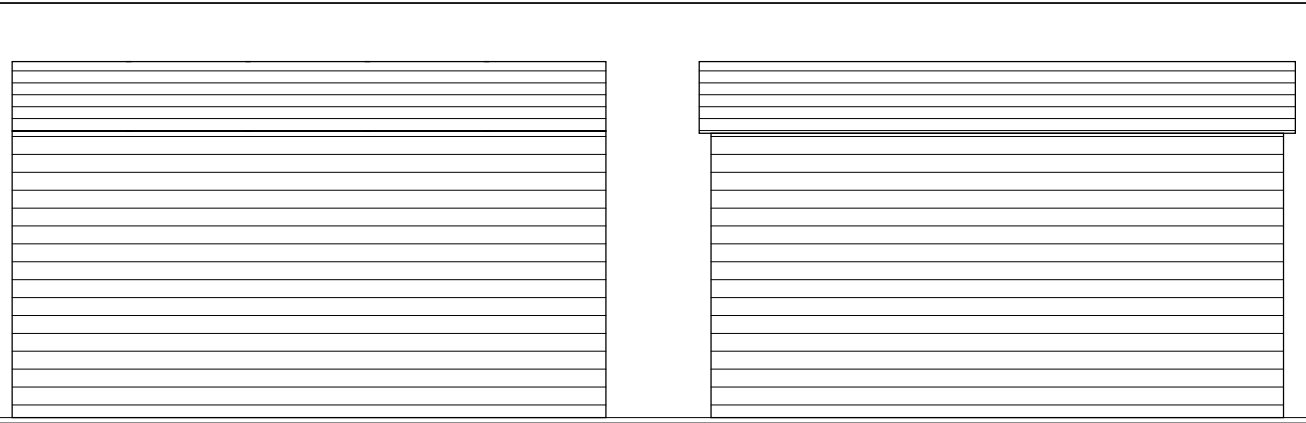

TYPICAL SIDE WALL ELEVATION - BOW FRAME, HORIZONTAL WALLS & ROOF

TYPICAL SIDE WALL ELEVATION - BOX EAVE, HORIZONTAL WALLS (OR LAP) & ROOF

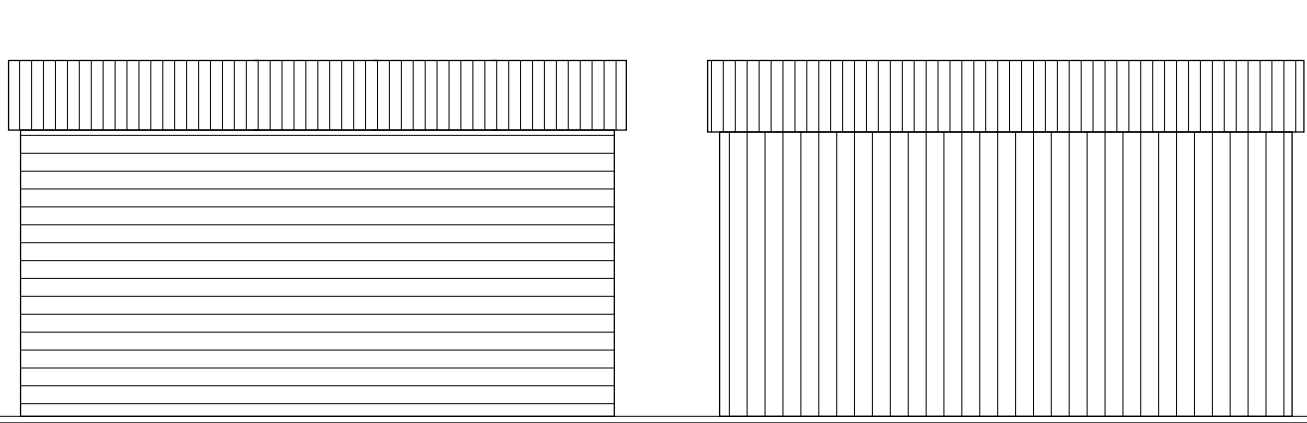

MAX. 16'-0" - STRUCTURAL HEADER

NON-STRUCTURAL HEADER

ROLL-UP DOOR (AS APPLICABLE)

SWINGING DOOR (AS APPLICABLE)

WINDOW (AS APPLICABLE)

12 GA. POST (EACH SIDE OF ALL ROLL-UP DOORS)

-4'-0" MAX.-

-4'-0" MAX.-

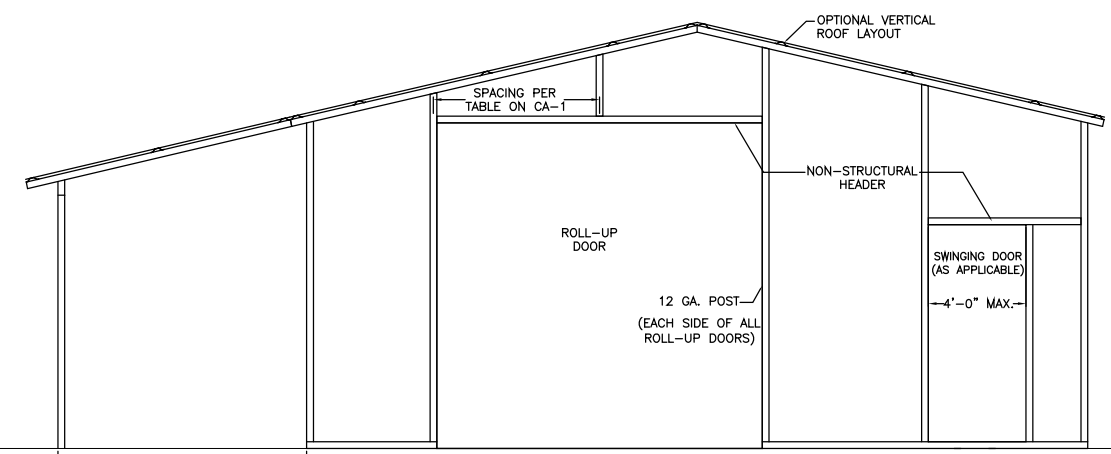

TYPICAL END ELEVATION

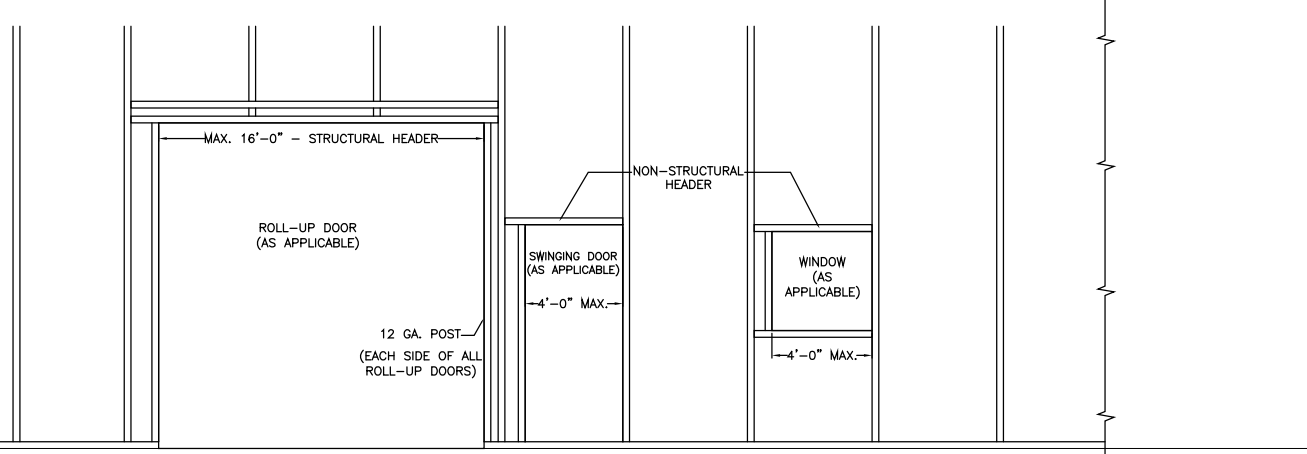

TYPICAL SIDE WALL ELEVATION

TITLE: LAYOUT VIEWS

Matthew T. Baldwin P.E.
Florida License #64608