



Lumber design values are in accordance with ANSI/TPI 1 section 6.3  
These truss designs rely on lumber values established by others.

RE: 5261258 -

MiTek, Inc.  
16023 Swingley Ridge Rd.  
Chesterfield, MO 63017  
314.434.1200

**Site Information:**

Customer Info: ROGERS Project Name: Rogers Res. Model: Custom  
Lot/Block: N/A Subdivision: N/A  
Address: 787 SW Heron Drive, N/A  
City: Fort White, State: FL

**Name Address and License # of Structural Engineer of Record, if there is one, for the building.**

Name: License #:  
Address:  
City: State:

**General Truss Engineering Criteria & Design Loads (Individual Truss Design Drawings Show Special Loading Conditions):**

Design Code: FBC2023/TPI2014 Design Program: MiTek 20/20 8.8  
Wind Code: ASCE 7-22 Wind Speed: 130 mph  
Roof Load: 40.0 psf Floor Load: N/A psf

This package includes 8 individual, Truss Design Drawings and 0 Additional Drawings.  
With my seal affixed to this sheet, I hereby certify that I am the Truss Design Engineer and this index sheet conforms to 61G15-31.003, section 5 of the Florida Board of Professional Engineers Rules.

No.	Seal#	Truss Name	Date
1	T40228939	CJ01	2/24/26
2	T40228940	CJ02	2/24/26
3	T40228941	CJ03	2/24/26
4	T40228942	EJ01	2/24/26
5	T40228943	HJ01	2/24/26
6	T40228944	T01	2/24/26
7	T40228945	T02	2/24/26
8	T40228946	T03	2/24/26

This item has been digitally signed and sealed by ORegan, Philip, PE on the date adjacent to the seal.  
Printed copies of this document are not considered signed and sealed and the signature must be verified on any electronic copies

The truss drawing(s) referenced above have been prepared by  
MiTek USA, Inc. under my direct supervision based on the parameters  
provided by Builders FirstSource-Lake City, FL.

Truss Design Engineer's Name: ORegan, Philip  
My license renewal date for the state of Florida is February 28, 2027.

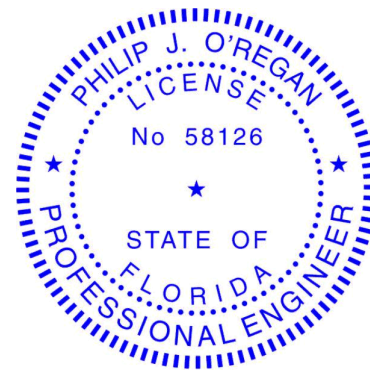

Philip J. O'Regan PE No.58126  
MiTek Inc. DBA MiTek USA FL Cert 6634  
16023 Swingley Ridge Rd. Chesterfield, MO 63017  
Date:

**IMPORTANT NOTE:** The seal on these truss component designs is a certification that the engineer named is licensed in the jurisdiction(s) identified and that the designs comply with ANSI/TPI 1. These designs are based upon parameters shown (e.g., loads, supports, dimensions, shapes and design codes), which were given to MiTek or TRENCO. Any project specific information included is for MiTek's or TRENCO's customers file reference purpose only, and was not taken into account in the preparation of these designs. MiTek or TRENCO has not independently verified the applicability of the design parameters or the designs for any particular building. Before use, the building designer should verify applicability of design parameters and properly incorporate these designs into the overall building design per ANSI/TPI 1, Chapter 2.

February 24, 2026

Job 5261258	Truss CJ01	Truss Type Jack-Open	Qty 8	Ply 1	Job Reference (optional) T40228939
----------------	---------------	-------------------------	----------	----------	---------------------------------------

Builders FirstSource (Lake City,FL), Lake City, FL - 32055,

Run: 8.83 S Jan 22 2026 Print: 8.830 S Jan 22 2026 MiTek Industries, Inc. Mon Feb 23 12:49:58  
ID:rZxR4slXmHq8GvDg2qtXdBzlcZr-RFC?PsB70Hq3NSgPqnL8w3ulTXbGKWrcDoi7J4zJC?#

Page: 1

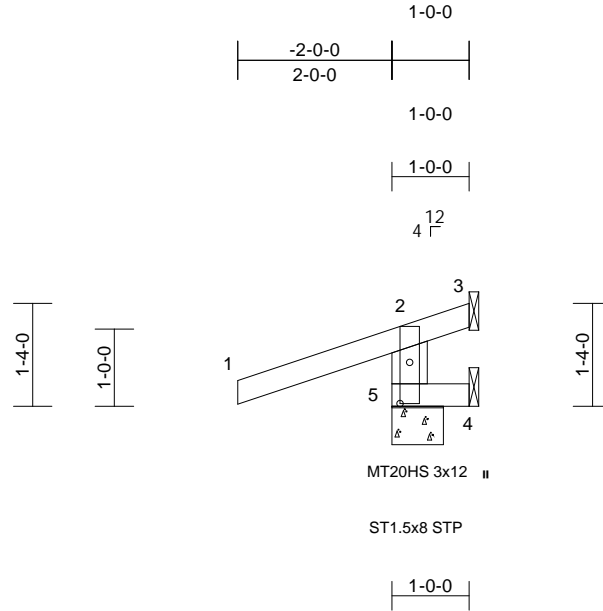

Scale = 1:29.9

Plate Offsets (X, Y): [5:0-6-6,0-1-8]

Loading	(psf)	Spacing	2-0-0	CSI	DEFL	in	(loc)	l/defl	L/d	PLATES	GRIP
TCLL (roof)	20.0	Plate Grip DOL	1.25	TC	0.60	Vert(LL)	0.00	4-5	>999	240	MT20HS 187/143
TCDL	10.0	Lumber DOL	1.25	BC	0.14	Vert(CT)	0.00	4-5	>999	180	MT20 244/190
BCLL	0.0*	Rep Stress Incr	YES	WB	0.00	Horz(CT)	0.00	3	n/a	n/a	
BCDL	10.0	Code	FBC2023/TPI2014	Matrix-MR							Weight: 8 lb FT = 20%

**LUMBER**

TOP CHORD 2x4 SP No.2  
BOT CHORD 2x4 SP No.2  
WEBS 2x6 SP No.2

**BRACING**

TOP CHORD Structural wood sheathing directly applied or 1-0-0 oc purlins, except end verticals.  
BOT CHORD Rigid ceiling directly applied or 10-0-0 oc bracing.

**REACTIONS**

(size) 3= Mechanical, 4= Mechanical, 5=0-8-0  
Max Horiz 5=48 (LC 9)  
Max Uplift 3=-100 (LC 1), 4=-66 (LC 1), 5=-292 (LC 8)  
Max Grav 3=87 (LC 8), 4=53 (LC 8), 5=361 (LC 1)

**FORCES**

(lb) - Maximum Compression/Maximum Tension

TOP CHORD 2-5=-279/570, 1-2=0/42, 2-3=-46/63  
BOT CHORD 4-5=0/0

**NOTES**

- Unbalanced roof live loads have been considered for this design.
- Wind: ASCE 7-22; Vult=130mph (3-second gust) Vasd=101mph; TCDL=4.2psf; BCDL=3.0psf; h=18ft; Cat. II; Exp C; Enclosed; MWFRS (envelope) exterior (2) zone and C-C Zone3 zone; end vertical left exposed;C-C for members and forces & MWFRS for reactions shown; Lumber DOL=1.60 plate grip DOL=1.60
- Building Designer / Project engineer responsible for verifying applied roof live load shown covers rain loading requirements specific to the use of this truss component.
- All plates are MT20 plates unless otherwise indicated.
- This truss has been designed for a 10.0 psf bottom chord live load nonconcurrent with any other live loads.

- \* This truss has been designed for a live load of 20.0psf on the bottom chord in all areas where a rectangle 3-06-00 tall by 2-00-00 wide will fit between the bottom chord and any other members.
- Refer to girder(s) for truss to truss connections.
- Provide mechanical connection (by others) of truss to bearing plate capable of withstanding 292 lb uplift at joint 5, 66 lb uplift at joint 4 and 100 lb uplift at joint 3.

**LOAD CASE(S)** Standard

This item has been digitally signed and sealed by ORegan, Philip, PE on the date indicated here. Printed copies of this document are not considered signed and sealed and the signature must be verified on any electronic copies.

Philip J. O'Regan PE No.58126  
MiTek Inc. DBA MiTek USA FL Cert 6634  
16023 Swingley Ridge Rd. Chesterfield, MO 63017  
Date:

February 24, 2026

**WARNING - Verify design parameters and READ NOTES ON THIS AND INCLUDED MITEK REFERENCE PAGE MII-7473 rev. 1/2/2023 BEFORE USE.**

Design valid for use only with MiTek® connectors. This design is based only upon parameters shown, and is for an individual building component, not a truss system. Before use, the building designer must verify the applicability of design parameters and properly incorporate this design into the overall building design. Bracing indicated is to prevent buckling of individual truss web and/or chord members only. Additional temporary and permanent bracing is always required for stability and to prevent collapse with possible personal injury and property damage. For general guidance regarding the fabrication, storage, delivery, erection and bracing of trusses and truss systems, see **ANSI/TPI1 Quality Criteria and DSB-22** available from Truss Plate Institute (www.tpinst.org) and **BCSI Building Component Safety Information** available from the Structural Building Component Association (www.sbcsccomponents.com)

**MiTek®**

16023 Swingley Ridge Rd.  
Chesterfield, MO 63017  
314.434.1200 / MiTek-US.com

Job 5261258	Truss CJ02	Truss Type Jack-Open	Qty 8	Ply 1	Job Reference (optional) T40228940
----------------	---------------	-------------------------	----------	----------	---------------------------------------

Builders FirstSource (Lake City,FL), Lake City, FL - 32055,

Run: 8.83 S Jan 22 2026 Print: 8.830 S Jan 22 2026 MiTek Industries, Inc. Mon Feb 23 12:49:59  
ID:hyd9fHGJoHLSAG1Lwem7TzlcWZ-RfC?PsB70Hq3NSgPqnL8w3uITXbGKWrCDoi7J4zJC?f

Page: 1

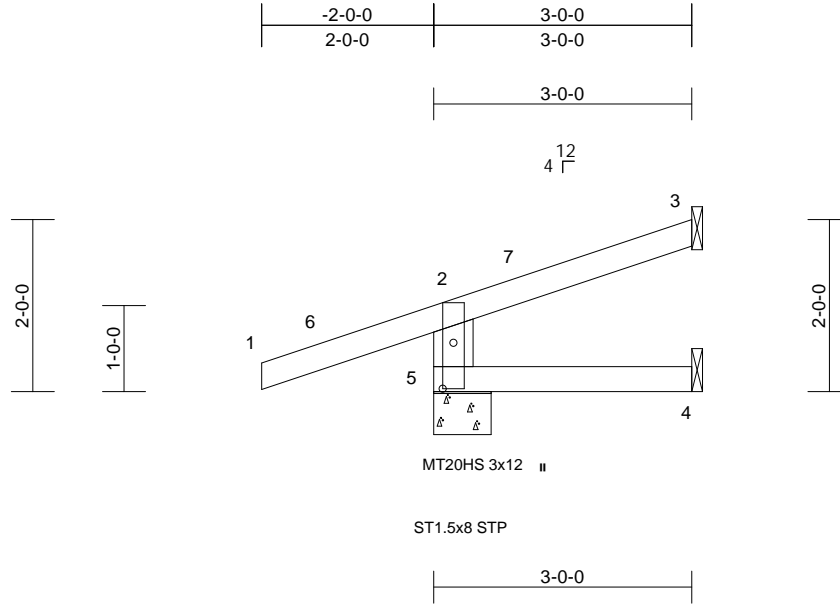

Scale = 1:26.8

Plate Offsets (X, Y): [5:0-6-6,0-1-8]

Loading	(psf)	Spacing	2-0-0	CSI	DEFL	in	(loc)	l/defl	L/d	PLATES	GRIP
TCLL (roof)	20.0	Plate Grip DOL	1.25	TC	0.60	Vert(LL)	-0.01	4-5	>999	240	MT20HS 187/143
TCDL	10.0	Lumber DOL	1.25	BC	0.11	Vert(CT)	-0.01	4-5	>999	180	MT20 244/190
BCLL	0.0*	Rep Stress Incr	YES	WB	0.00	Horz(CT)	0.01	3	n/a	n/a	
BCDL	10.0	Code	FBC2023/TPI2014	Matrix-MR							Weight: 14 lb FT = 20%

**LUMBER**

TOP CHORD 2x4 SP No.2  
BOT CHORD 2x4 SP No.2  
WEBS 2x6 SP No.2

**BRACING**

TOP CHORD Structural wood sheathing directly applied or 3-0-0 oc purlins, except end verticals.  
BOT CHORD Rigid ceiling directly applied or 10-0-0 oc bracing.

**REACTIONS**

(size) 3= Mechanical, 4= Mechanical, 5=0-8-0  
Max Horiz 5=77 (LC 8)  
Max Uplift 3=-45 (LC 12), 5=-199 (LC 8)  
Max Grav 3=45 (LC 1), 4=43 (LC 3), 5=297 (LC 1)

**FORCES**

(lb) - Maximum Compression/Maximum Tension

TOP CHORD 2-5=-251/459, 1-2=0/42, 2-3=-41/22  
BOT CHORD 4-5=0/0

**NOTES**

- 1) Unbalanced roof live loads have been considered for this design.
- 2) Wind: ASCE 7-22; Vult=130mph (3-second gust) Vasd=101mph; TCDL=4.2psf; BCDL=3.0psf; h=18ft; Cat. II; Exp C; Enclosed; MWFRS (envelope) exterior (2) zone and C-C Zone3 -2-0-0 to 1-0-0, Zone1 1-0-0 to 2-11-4 zone; end vertical left exposed;C-C for members and forces & MWFRS for reactions shown; Lumber DOL=1.60 plate grip DOL=1.60
- 3) Building Designer / Project engineer responsible for verifying applied roof live load shown covers rain loading requirements specific to the use of this truss component.
- 4) All plates are MT20 plates unless otherwise indicated.
- 5) This truss has been designed for a 10.0 psf bottom chord live load nonconcurrent with any other live loads.

- 6) \* This truss has been designed for a live load of 20.0psf on the bottom chord in all areas where a rectangle 3-06-00 tall by 2-00-00 wide will fit between the bottom chord and any other members.
- 7) Refer to girder(s) for truss to truss connections.
- 8) Provide mechanical connection (by others) of truss to bearing plate capable of withstanding 199 lb uplift at joint 5 and 45 lb uplift at joint 3.

**LOAD CASE(S)** Standard

This item has been digitally signed and sealed by ORegan, Philip, PE on the date indicated here. Printed copies of this document are not considered signed and sealed and the signature must be verified on any electronic copies.

Philip J. O'Regan PE No.58126  
MiTek Inc. DBA MiTek USA FL Cert 6634  
16023 Swingley Ridge Rd. Chesterfield, MO 63017  
Date:

February 24, 2026

**WARNING - Verify design parameters and READ NOTES ON THIS AND INCLUDED MITEK REFERENCE PAGE MII-7473 rev. 1/2/2023 BEFORE USE.**

Design valid for use only with MiTek® connectors. This design is based only upon parameters shown, and is for an individual building component, not a truss system. Before use, the building designer must verify the applicability of design parameters and properly incorporate this design into the overall building design. Bracing indicated is to prevent buckling of individual truss web and/or chord members only. Additional temporary and permanent bracing is always required for stability and to prevent collapse with possible personal injury and property damage. For general guidance regarding the fabrication, storage, delivery, erection and bracing of trusses and truss systems, see **ANSI/TPI1 Quality Criteria and DSB-22** available from Truss Plate Institute (www.tpinst.org) and **BCSI Building Component Safety Information** available from the Structural Building Component Association (www.sbcsccomponents.com)

**MiTek®**

16023 Swingley Ridge Rd.  
Chesterfield, MO 63017  
314.434.1200 / MiTek-US.com

Job 5261258	Truss CJ03	Truss Type Jack-Open	Qty 8	Ply 1	Job Reference (optional) T40228941
----------------	---------------	-------------------------	----------	----------	---------------------------------------

Builders FirstSource (Lake City,FL), Lake City, FL - 32055,

Run: 8.83 S Jan 22 2026 Print: 8.830 S Jan 22 2026 MiTek Industries, Inc. Mon Feb 23 12:49:59

Page: 1

ID:tXcFFxP9aMPJ20IQUf5WCZlcGw-RfC?PsB70Hq3NSgPqnL8w3ulTXbGKWrCDoi7J4zJC?f

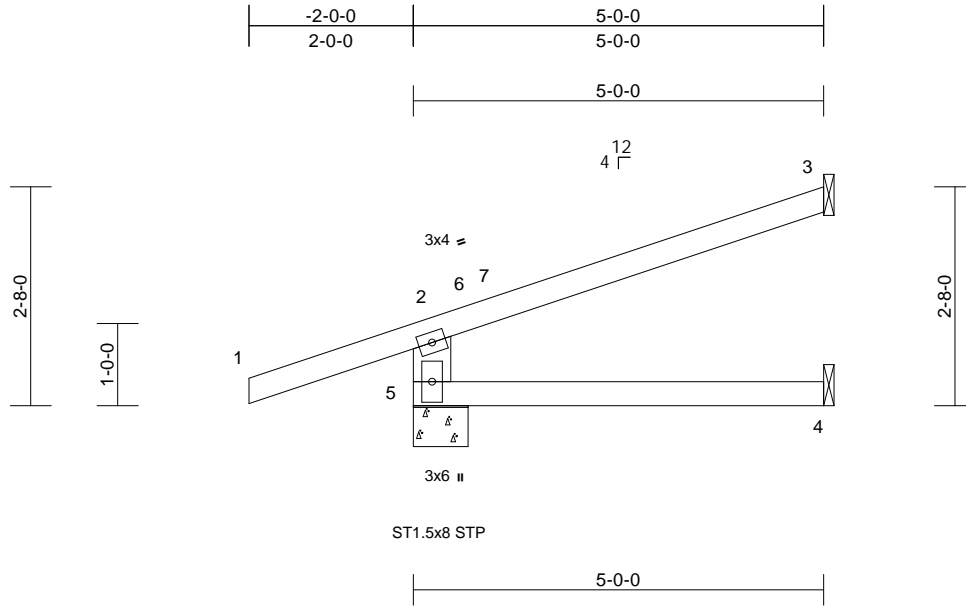

Loading	(psf)	Spacing	2-0-0	CSI	DEFL	in	(loc)	l/defl	L/d	PLATES	GRIP	
TCLL (roof)	20.0	Plate Grip DOL	1.25	TC	0.60	Vert(LL)	0.03	4-5	>999	240	MT20	244/190
TCDL	10.0	Lumber DOL	1.25	BC	0.29	Vert(CT)	-0.04	4-5	>999	180		
BCLL	0.0*	Rep Stress Incr	YES	WB	0.00	Horz(CT)	-0.03	3	n/a	n/a		
BCDL	10.0	Code	FBC2023/TPI2014	Matrix-MR							Weight: 20 lb	FT = 20%

**LUMBER**  
 TOP CHORD 2x4 SP No.2  
 BOT CHORD 2x4 SP No.2  
 WEBS 2x6 SP No.2

7) Provide mechanical connection (by others) of truss to bearing plate capable of withstanding 208 lb uplift at joint 5 and 91 lb uplift at joint 3.

**LOAD CASE(S)** Standard

**BRACING**  
 TOP CHORD Structural wood sheathing directly applied or 5-0-0 oc purlins, except end verticals.  
 BOT CHORD Rigid ceiling directly applied or 10-0-0 oc bracing.

**REACTIONS** (size) 3= Mechanical, 4= Mechanical, 5=0-8-0  
 Max Horiz 5=109 (LC 8)  
 Max Uplift 3=-91 (LC 12), 5=-208 (LC 8)  
 Max Grav 3=113 (LC 1), 4=84 (LC 3), 5=354 (LC 1)

**FORCES** (lb) - Maximum Compression/Maximum Tension  
 TOP CHORD 2-5=-303/505, 1-2=0/42, 2-3=-79/38  
 BOT CHORD 4-5=0/0

- NOTES**
- 1) Unbalanced roof live loads have been considered for this design.
  - 2) Wind: ASCE 7-22; Vult=130mph (3-second gust) Vasd=101mph; TCDL=4.2psf; BCDL=3.0psf; h=18ft; Cat. II; Exp C; Enclosed; MWFRS (envelope) exterior (2) zone and C-C Zone3 -2-0-0 to 1-0-0, Zone1 1-0-0 to 4-11-4 zone; end vertical left exposed;C-C for members and forces & MWFRS for reactions shown; Lumber DOL=1.60 plate grip DOL=1.60
  - 3) Building Designer / Project engineer responsible for verifying applied roof live load shown covers rain loading requirements specific to the use of this truss component.
  - 4) This truss has been designed for a 10.0 psf bottom chord live load nonconcurrent with any other live loads.
  - 5) \* This truss has been designed for a live load of 20.0psf on the bottom chord in all areas where a rectangle 3-06-00 tall by 2-00-00 wide will fit between the bottom chord and any other members.
  - 6) Refer to girder(s) for truss to truss connections.

This item has been digitally signed and sealed by ORegan, Philip, PE on the date indicated here. Printed copies of this document are not considered signed and sealed and the signature must be verified on any electronic copies.

Philip J. O'Regan PE No.58126  
 MiTek Inc. DBA MiTek USA FL Cert 6634  
 16023 Swingley Ridge Rd. Chesterfield, MO 63017  
 Date:

February 24, 2026

**WARNING - Verify design parameters and READ NOTES ON THIS AND INCLUDED MITEK REFERENCE PAGE MII-7473 rev. 1/2/2023 BEFORE USE.**

Design valid for use only with MiTek® connectors. This design is based only upon parameters shown, and is for an individual building component, not a truss system. Before use, the building designer must verify the applicability of design parameters and properly incorporate this design into the overall building design. Bracing indicated is to prevent buckling of individual truss web and/or chord members only. Additional temporary and permanent bracing is always required for stability and to prevent collapse with possible personal injury and property damage. For general guidance regarding the fabrication, storage, delivery, erection and bracing of trusses and truss systems, see **ANSI/TPI1 Quality Criteria and DSB-22** available from Truss Plate Institute (www.tpinst.org) and **BCSI Building Component Safety Information** available from the Structural Building Component Association (www.sbcsccomponents.com)

**MiTek®**

16023 Swingley Ridge Rd.  
 Chesterfield, MO 63017  
 314.434.1200 / MiTek-US.com

Job 5261258	Truss EJ01	Truss Type Jack-Partial	Qty 8	Ply 1	Job Reference (optional)	T40228942
----------------	---------------	----------------------------	----------	----------	--------------------------	-----------

Builders FirstSource (Lake City,FL), Lake City, FL - 32055,

Run: 8.83 S Jan 22 2026 Print: 8.830 S Jan 22 2026 MiTek Industries, Inc. Mon Feb 23 12:50:00  
ID:A93JH8hCwkQvwi71uhX8AdzlcGY-RfC?PsB70Hq3NSgPqnL8w3ulTXbGKWrCDoi7J4zJC?f

Page: 1

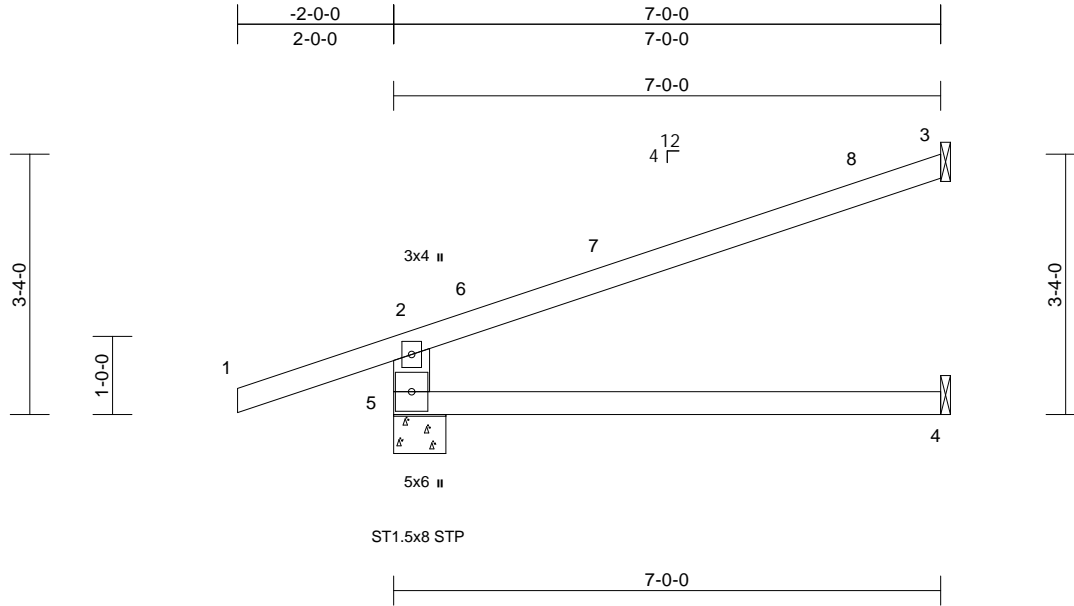

Scale = 1:29.5

Loading	(psf)	Spacing	2-0-0	CSI	DEFL	in	(loc)	l/defl	L/d	PLATES	GRIP	
TCLL (roof)	20.0	Plate Grip DOL	1.25	TC	0.85	Vert(LL)	0.13	4-5	>621	240	MT20	244/190
TCDL	10.0	Lumber DOL	1.25	BC	0.57	Vert(CT)	-0.20	4-5	>412	180		
BCLL	0.0*	Rep Stress Incr	YES	WB	0.00	Horz(CT)	-0.08	3	n/a	n/a		
BCDL	10.0	Code	FBC2023/TPI2014	Matrix-MR							Weight: 26 lb	FT = 20%

**LUMBER**

TOP CHORD 2x4 SP No.2  
BOT CHORD 2x4 SP No.2  
WEBS 2x6 SP No.2

- Refer to girder(s) for truss to truss connections.
- Provide mechanical connection (by others) of truss to bearing plate capable of withstanding 229 lb uplift at joint 5, 129 lb uplift at joint 3 and 2 lb uplift at joint 4.

**BRACING**

TOP CHORD Structural wood sheathing directly applied or 2-2-0 oc purlins, except end verticals.  
BOT CHORD Rigid ceiling directly applied or 10-0-0 oc bracing.

**LOAD CASE(S)** Standard

**REACTIONS**

(size) 3= Mechanical, 4= Mechanical, 5=0-8-0  
Max Horiz 5=142 (LC 8)  
Max Uplift 3=-129 (LC 8), 4=-2 (LC 12), 5=-229 (LC 8)  
Max Grav 3=173 (LC 1), 4=123 (LC 3), 5=424 (LC 1)

**FORCES**

(lb) - Maximum Compression/Maximum Tension

TOP CHORD 2-5=-363/522, 1-2=0/42, 2-3=-104/50  
BOT CHORD 4-5=0/0

**NOTES**

- Unbalanced roof live loads have been considered for this design.
- Wind: ASCE 7-22; Vult=130mph (3-second gust) Vasd=101mph; TCDL=4.2psf; BCDL=3.0psf; h=18ft; Cat. II; Exp C; Enclosed; MWFRS (envelope) exterior (2) zone and C-C Zone3 -2-0-0 to 1-0-0, Zone1 1-0-0 to 6-11-4 zone; end vertical left exposed; C-C for members and forces & MWFRS for reactions shown; Lumber DOL=1.60 plate grip DOL=1.60
- Building Designer / Project engineer responsible for verifying applied roof live load shown covers rain loading requirements specific to the use of this truss component.
- This truss has been designed for a 10.0 psf bottom chord live load nonconcurrent with any other live loads.
- \* This truss has been designed for a live load of 20.0psf on the bottom chord in all areas where a rectangle 3-06-00 tall by 2-00-00 wide will fit between the bottom chord and any other members.

This item has been digitally signed and sealed by ORegan, Philip, PE on the date indicated here. Printed copies of this document are not considered signed and sealed and the signature must be verified on any electronic copies.

Philip J. O'Regan PE No.58126  
MiTek Inc. DBA MiTek USA FL Cert 6634  
16023 Swingley Ridge Rd. Chesterfield, MO 63017  
Date:

February 24, 2026

**WARNING - Verify design parameters and READ NOTES ON THIS AND INCLUDED MITEK REFERENCE PAGE MII-7473 rev. 1/2/2023 BEFORE USE.**

Design valid for use only with MiTek® connectors. This design is based only upon parameters shown, and is for an individual building component, not a truss system. Before use, the building designer must verify the applicability of design parameters and properly incorporate this design into the overall building design. Bracing indicated is to prevent buckling of individual truss web and/or chord members only. Additional temporary and permanent bracing is always required for stability and to prevent collapse with possible personal injury and property damage. For general guidance regarding the fabrication, storage, delivery, erection and bracing of trusses and truss systems, see **ANSI/TPI1 Quality Criteria and DSB-22** available from Truss Plate Institute (www.tpinst.org) and **BCSI Building Component Safety Information** available from the Structural Building Component Association (www.sbcsccomponents.com)

**MiTek®**

16023 Swingley Ridge Rd.  
Chesterfield, MO 63017  
314.434.1200 / MiTek-US.com





Job 5261258	Truss T02	Truss Type Hip	Qty 2	Ply 1	Job Reference (optional)	T40228945
----------------	--------------	-------------------	----------	----------	--------------------------	-----------

Builders FirstSource (Lake City,FL), Lake City, FL - 32055,

Run: 8.83 S Jan 22 2026 Print: 8.830 S Jan 22 2026 MiTek Industries, Inc. Mon Feb 23 12:50:01  
ID:wYPL4aGxyZIUfqlw5lPP8zlc5T-RfC?PsB70Hq3NSgPqnL8w3uITXbGKWrCD0i7J4zJC?f

Page: 1

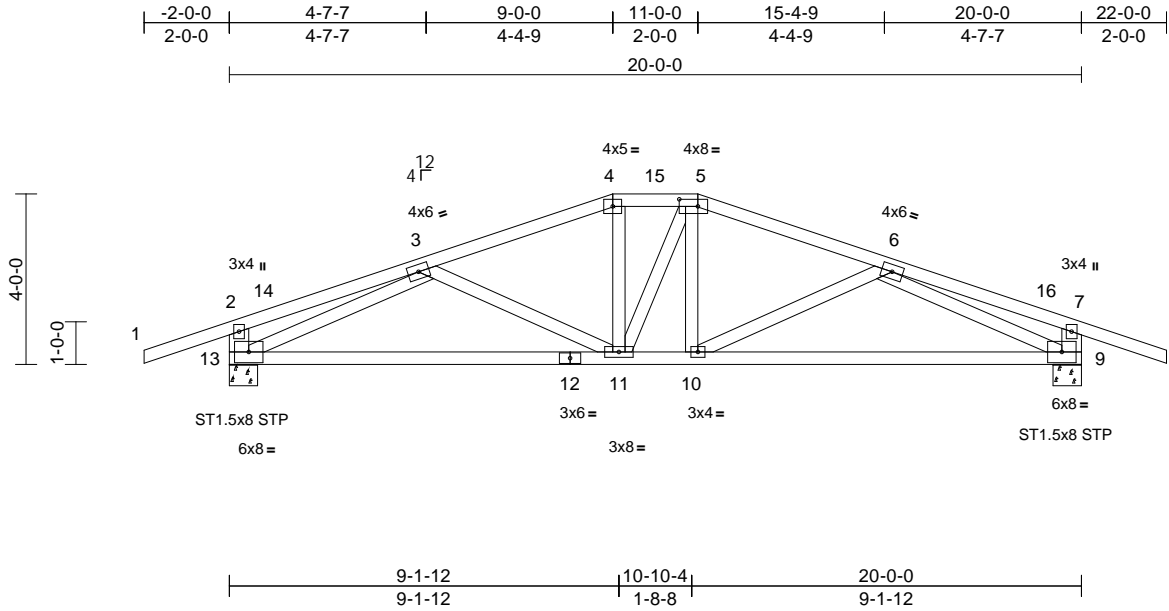

Scale = 1:54.1

Plate Offsets (X, Y): [5:0-5-4,0-2-0]

Loading	(psf)	Spacing	2-0-0	CSI	DEFL	in	(loc)	l/defl	L/d	PLATES	GRIP	
TCLL (roof)	20.0	Plate Grip DOL	1.25	TC	0.38	Vert(LL)	-0.16	9-10	>999	240	MT20	244/190
TCDL	10.0	Lumber DOL	1.25	BC	0.74	Vert(CT)	-0.33	9-10	>706	180		
BCLL	0.0*	Rep Stress Incr	YES	WB	0.53	Horz(CT)	0.04	9	n/a	n/a		
BCDL	10.0	Code	FBC2023/TPI2014	Matrix-MS							Weight: 114 lb	FT = 20%

**LUMBER**

- TOP CHORD 2x4 SP No.2
- BOT CHORD 2x4 SP No.2
- WEBS 2x4 SP No.3 \*Except\* 13-2,9-7:2x6 SP No.2

**BRACING**

- TOP CHORD Structural wood sheathing directly applied or 5-2-12 oc purlins, except end verticals.
- BOT CHORD Rigid ceiling directly applied or 7-10-9 oc bracing.

**REACTIONS**

- (size) 9=0-8-0, 13=0-8-0
- Max Horiz 13=46 (LC 17)
- Max Uplift 9=-431 (LC 9), 13=-431 (LC 8)
- Max Grav 9=915 (LC 1), 13=915 (LC 1)

**FORCES**

- (lb) - Maximum Compression/Maximum Tension
- TOP CHORD 1-2=0/42, 2-3=-256/54, 3-4=-1116/554, 4-5=-1021/564, 5-6=-1115/565, 6-7=-256/55, 7-8=0/42, 2-13=-311/263, 7-9=-311/263
- BOT CHORD 11-13=-553/1111, 10-11=-362/1021, 9-10=-516/1111
- WEBS 3-11=-142/185, 4-11=-52/209, 5-11=-93/96, 5-10=-45/208, 6-10=-142/185, 3-13=-1138/692, 6-9=-1137/683

**NOTES**

- Unbalanced roof live loads have been considered for this design.
- Wind: ASCE 7-22; Vult=130mph (3-second gust) Vasd=101mph; TCDL=4.2psf; BCDL=3.0psf; h=18ft; Cat. II; Exp C; Enclosed; MWFRS (envelope) exterior (2) zone and C-C Zone3 -2-0-0 to 1-0-0, Zone1 1-0-0 to 9-0-0, Zone3 9-0-0 to 11-0-0, Zone2 11-0-0 to 15-5-2, Zone1 15-5-2 to 22-0-0 zone; end vertical left and right exposed;C-C for members and forces & MWFRS for reactions shown; Lumber DOL=1.60 plate grip DOL=1.60
- Building Designer / Project engineer responsible for verifying applied roof live load shown covers rain loading requirements specific to the use of this truss component.

- Provide adequate drainage to prevent water ponding.
- This truss has been designed for a 10.0 psf bottom chord live load nonconcurrent with any other live loads.
- \* This truss has been designed for a live load of 20.0psf on the bottom chord in all areas where a rectangle 3-06-00 tall by 2-00-00 wide will fit between the bottom chord and any other members.
- Provide mechanical connection (by others) of truss to bearing plate capable of withstanding 431 lb uplift at joint 13 and 431 lb uplift at joint 9.

**LOAD CASE(S)** Standard

This item has been digitally signed and sealed by ORegan, Philip, PE on the date indicated here. Printed copies of this document are not considered signed and sealed and the signature must be verified on any electronic copies.

Philip J. O'Regan PE No.58126  
MiTek Inc. DBA MiTek USA FL Cert 6634  
16023 Swingley Ridge Rd. Chesterfield, MO 63017  
Date:

February 24,2026

**WARNING - Verify design parameters and READ NOTES ON THIS AND INCLUDED MITEK REFERENCE PAGE MII-7473 rev. 1/2/2023 BEFORE USE.**

Design valid for use only with MiTek® connectors. This design is based only upon parameters shown, and is for an individual building component, not a truss system. Before use, the building designer must verify the applicability of design parameters and properly incorporate this design into the overall building design. Bracing indicated is to prevent buckling of individual truss web and/or chord members only. Additional temporary and permanent bracing is always required for stability and to prevent collapse with possible personal injury and property damage. For general guidance regarding the fabrication, storage, delivery, erection and bracing of trusses and truss systems, see **ANSI/TPI1 Quality Criteria and DSB-22** available from Truss Plate Institute (www.tpinst.org) and **BCSI Building Component Safety Information** available from the Structural Building Component Association (www.sbcsccomponents.com)

**MiTek®**

16023 Swingley Ridge Rd.  
Chesterfield, MO 63017  
314.434.1200 / MiTek-US.com

Job 5261258	Truss T03	Truss Type Common	Qty 10	Ply 1	Job Reference (optional)	T40228946
----------------	--------------	----------------------	-----------	----------	--------------------------	-----------

Builders FirstSource (Lake City,FL), Lake City, FL - 32055,

Run: 8.83 S Jan 22 2026 Print: 8.830 S Jan 22 2026 MiTek Industries, Inc. Mon Feb 23 12:50:01  
ID:Zn0AKQbp8MiFm2YXeKkG8Kzlc6L-RfC?PsB70Hq3NSgPqnL8w3ulTXbGKWrCDoi7J4zJC?f

Page: 1

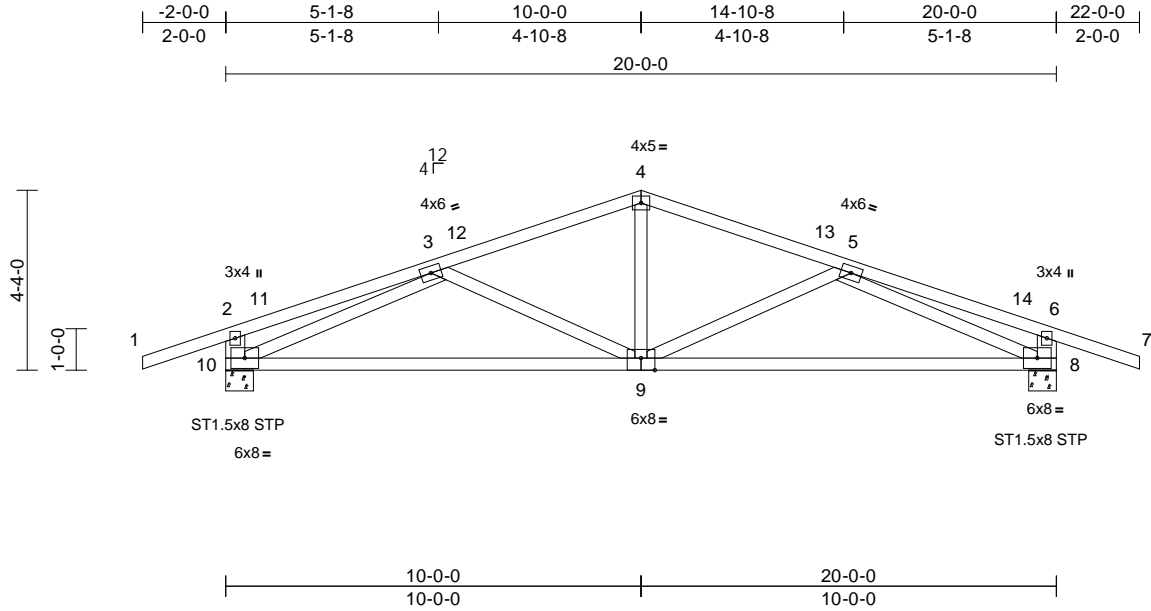

Scale = 1:55.5

Plate Offsets (X, Y): [9:0-4-0,Edge]

Loading	(psf)	Spacing	2-0-0	CSI	DEFL	in	(loc)	l/defl	L/d	PLATES	GRIP	
TCLL (roof)	20.0	Plate Grip DOL	1.25	TC	0.43	Vert(LL)	-0.18	8-9	>999	240	MT20	244/190
TCDL	10.0	Lumber DOL	1.25	BC	0.97	Vert(CT)	-0.37	8-9	>631	180		
BCLL	0.0*	Rep Stress Incr	YES	WB	0.63	Horz(CT)	0.04	8	n/a	n/a		
BCDL	10.0	Code	FBC2023/TPI2014	Matrix-MS							Weight: 107 lb	FT = 20%

**LUMBER**

TOP CHORD 2x4 SP No.2  
 BOT CHORD 2x4 SP No.2  
 WEBS 2x4 SP No.3 \*Except\* 8-6,10-2:2x6 SP No.2

**BRACING**

TOP CHORD Structural wood sheathing directly applied or 5-5-5 oc purlins, except end verticals.  
 BOT CHORD Rigid ceiling directly applied or 2-2-0 oc bracing.

**REACTIONS**

(size) 8=0-8-0, 10=0-8-0  
 Max Horiz 10=53 (LC 13)  
 Max Uplift 8=-422 (LC 9), 10=-422 (LC 8)  
 Max Grav 8=915 (LC 1), 10=915 (LC 1)

**FORCES**

(lb) - Maximum Compression/Maximum Tension

TOP CHORD 1-2=0/42, 2-3=-283/68, 3-4=-1075/486,  
 4-5=-1075/486, 5-6=-283/68, 6-7=0/42,  
 6-8=-333/300, 2-10=-333/300  
 BOT CHORD 8-10=-496/1128  
 WEBS 4-9=-86/435, 5-9=-224/234, 3-9=-224/233,  
 5-8=-1117/649, 3-10=-1117/649

**NOTES**

- Unbalanced roof live loads have been considered for this design.
- Wind: ASCE 7-22; Vult=130mph (3-second gust) Vasd=101mph; TCDL=4.2psf; BCDL=3.0psf; h=18ft; Cat. II; Exp C; Enclosed; MWFRS (envelope) exterior (2) zone and C-C Zone3 -2-0-0 to 1-0-0, Zone1 1-0-0 to 10-0-0, Zone2 10-0-0 to 14-2-15, Zone1 14-2-15 to 22-0-0 zone; end vertical left and right exposed; C-C for members and forces & MWFRS for reactions shown; Lumber DOL=1.60 plate grip DOL=1.60
- Building Designer / Project engineer responsible for verifying applied roof live load shown covers rain loading requirements specific to the use of this truss component.
- This truss has been designed for a 10.0 psf bottom chord live load nonconcurrent with any other live loads.

- \* This truss has been designed for a live load of 20.0psf on the bottom chord in all areas where a rectangle 3-06-00 tall by 2-00-00 wide will fit between the bottom chord and any other members.
- Provide mechanical connection (by others) of truss to bearing plate capable of withstanding 422 lb uplift at joint 8 and 422 lb uplift at joint 10.

**LOAD CASE(S)** Standard

This item has been digitally signed and sealed by ORegan, Philip, PE on the date indicated here. Printed copies of this document are not considered signed and sealed and the signature must be verified on any electronic copies.

Philip J. O'Regan PE No.58126  
 MiTek Inc. DBA MiTek USA FL Cert 6634  
 16023 Swingley Ridge Rd. Chesterfield, MO 63017  
 Date:

February 24, 2026

**WARNING - Verify design parameters and READ NOTES ON THIS AND INCLUDED MITEK REFERENCE PAGE MII-7473 rev. 1/2/2023 BEFORE USE.**

Design valid for use only with MiTek® connectors. This design is based only upon parameters shown, and is for an individual building component, not a truss system. Before use, the building designer must verify the applicability of design parameters and properly incorporate this design into the overall building design. Bracing indicated is to prevent buckling of individual truss web and/or chord members only. Additional temporary and permanent bracing is always required for stability and to prevent collapse with possible personal injury and property damage. For general guidance regarding the fabrication, storage, delivery, erection and bracing of trusses and truss systems, see **ANSI/TPI1 Quality Criteria and DSB-22** available from Truss Plate Institute (www.tpinst.org) and **BCSI Building Component Safety Information** available from the Structural Building Component Association (www.sbcsccomponents.com)

**MiTek®**

16023 Swingley Ridge Rd.  
 Chesterfield, MO 63017  
 314.434.1200 / MiTek-US.com

# Symbols

## PLATE LOCATION AND ORIENTATION

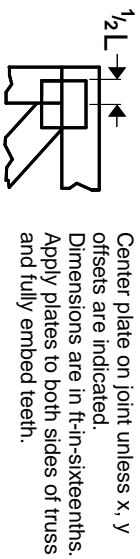

Center plate on joint unless x, y offsets are indicated. Dimensions are in ft-in-sixteenths. Apply plates to both sides of truss and fully embed teeth.

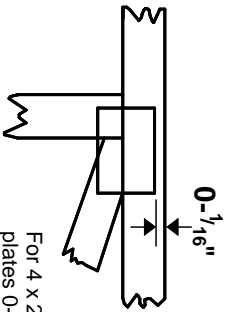

For 4 x 2 orientation, locate plates 0- 1/16\" from outside edge of truss.



This symbol indicates the required direction of slots in connector plates.

\* Plate location details available in MITtek software or upon request.

## PLATE SIZE

4 X 4

The first dimension is the plate width measured perpendicular to slots. Second dimension is the length parallel to slots.

## LATERAL BRACING LOCATION



Indicated by symbol shown and/or by text in the bracing section of the output. Use T or I bracing if indicated.

## BEARING

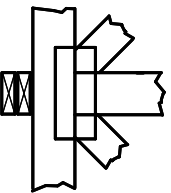

Indicates location where bearings (supports) occur. Icons vary but reaction section indicates joint number/letter where bearings occur. Min size shown is for crushing only.

## Industry Standards:

ANSI/TP1: National Design Specification for Metal Plate Connected Wood Truss Construction.  
DSB-22: Design Standard for Bracing.  
BCSI: Building Component Safety Information, Guide to Good Practice for Handling, Installing, Restraining & Bracing of Metal Plate Connected Wood Trusses.

# Numbering System

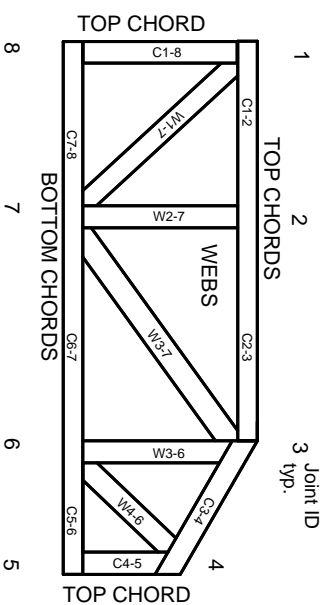

JOINTS ARE GENERALLY NUMBERED/LETTERED CLOCKWISE AROUND THE TRUSS STARTING AT THE JOINT FARTHEST TO THE LEFT.

CHORDS AND WEBS ARE IDENTIFIED BY END JOINT NUMBERS/LETTERS.

## Product Code Approvals

ICC-ES Reports:

ESR-1-1988, ESR-2-362, ESR-2-685, ESR-3-282  
ESR-4-722, ESL-1-388

## Design General Notes

Trusses are designed for wind loads in the plane of the truss unless otherwise shown.

Lumber design values are in accordance with ANSI/TP1 section 6.3. These truss designs rely on Lumber values established by others.

© 2023 MITtek® All Rights Reserved

# General Safety Notes

## Failure to Follow Could Cause Property Damage or Personal Injury

1. Additional stability/bracing for truss system, e.g. diagonal or X-bracing, is always required. See BCSI.
2. Truss bracing must be designed by an engineer. For wide truss spacing, individual lateral braces themselves may require bracing, or alternative Tor I bracing should be considered.
3. Never exceed the design loading shown and never stack materials on inadequately braced trusses.
4. Provide copies of this truss design to the building designer, erection supervisor, property owner and all other interested parties.
5. Cut members to bear tightly against each other.
6. Place plates on each face of truss at each joint and embed fully. Knots and wane at joint locations are regulated by ANSI/TP1 1.
7. Design assumes trusses will be suitably protected from the environment in accord with ANSI/TP1 1.
8. Unless otherwise noted, moisture content of lumber shall not exceed 19% at time of fabrication.
9. Unless expressly noted, this design is not applicable for use with fire retardant, preservative treated, or green lumber.
10. Camber is a non-structural consideration and is the responsibility of truss fabricator. General practice is to camber for dead load deflection.
11. Plate type, size, orientation and location dimensions indicated are minimum plating requirements.
12. Lumber used shall be of the species and size, and in all respects, equal to or better than that specified.
13. Top chords must be sheathed or purlins provided at spacing indicated on design.
14. Bottom chords require lateral bracing at 10 ft. spacing, or less, if no ceiling is installed, unless otherwise noted.
15. Connections not shown are the responsibility of others.
16. Do not cut or alter truss member or plate without prior approval of an engineer.
17. Install and load vertically unless indicated otherwise.
18. Use of green or treated lumber may pose unacceptable environmental, health or performance risks. Consult with project engineer before use.
19. Review all portions of this design (front, back, words and pictures) before use. Reviewing pictures alone is not sufficient.
20. Design assumes manufacture in accordance with ANSI/TP1 1 Quality Criteria.
21. The design does not take into account any dynamic or other loads other than those expressly stated.

# MITek®

MITtek Engineering Reference Sheet: Mill-7473 rev. 1/2/2023