

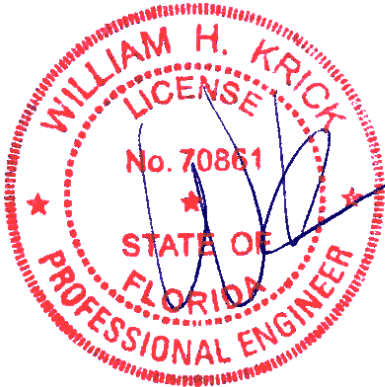

Alpine, an ITW Company
 155 Harlem Ave
 North Building, 4th Floor
 Glenview, IL 60025
 Phone: (800)755-6001
 www.alpineitw.com



This item has been digitally signed by William H. Krick on the date adjacent to the seal.

Printed copies of this document are not considered signed and sealed and the signature must be verified on any electronic copies.

COA #0 278

Florida Certificate of Product Approval #FL 1999

02/02/2026



Site Information:	Page 1:
Customer: W. B. Howland Company, Inc.	Job Number: 26-3432
Job Description: MOORE	
Address:	

Job Engineering Criteria:	
Design Code: FBC 8th Ed. 2023 Res.	IntelliVIEW Version: 24.02.00D JRef #: 1YH82150009
Wind Standard: ASCE 7-22 Wind Speed (mph): 130	Design Loading (psf): 40
Building Type: Enclosed	

This package contains general notes pages, 36 truss drawing(s) and 4 detail(s).

Item	Drawing Number	Truss
1	030.26.1736.43760	A01
3	030.26.1736.59640	A03
5	030.26.1737.23343	A05
7	030.26.1737.33290	A07
9	030.26.1737.52613	A09
11	030.26.1738.09940	B02
13	030.26.1738.21383	HJ02
15	030.26.1738.26640	J02
17	030.26.1738.33367	J04
19	030.26.1738.37280	J06
21	030.26.1738.41493	J08
23	030.26.1739.16043	PB02
25	030.26.1739.22593	PB04
27	030.26.1739.28887	PB06
29	030.26.1739.33150	PB08
31	030.26.1739.37113	V02
33	030.26.1739.40620	V04
35	030.26.1739.43850	V06
37	BRCLBSUB0119	
39	VAL180220723	

Item	Drawing Number	Truss
2	030.26.1736.55843	A02
4	030.26.1737.20477	A04
6	030.26.1737.28677	A06
8	030.26.1737.36053	A08
10	030.26.1738.07050	B01
12	030.26.1738.15607	HJ01
14	030.26.1738.23883	J01
16	030.26.1738.30370	J03
18	030.26.1738.35000	J05
20	030.26.1738.38883	J07
22	030.26.1739.11337	PB01
24	030.26.1739.20870	PB03
26	030.26.1739.25767	PB05
28	030.26.1739.31380	PB07
30	030.26.1739.35460	V01
32	030.26.1739.38800	V03
34	030.26.1739.42140	V05
36	030.26.1739.47233	V07
38	PB160220723	
40	VALTN220723	

General Notes

Truss Design Engineer Scope of Work, Design Assumptions and Design Responsibilities:

The design responsibilities assumed in the preparation of these design drawings are those specified in ANSI/TPI 1, Chapter 2; and the National Design Standard for Metal Plate Connected Wood Truss Construction, by the Truss Plate Institute. The truss component designs conform to the applicable provisions of ANSI/TPI 1 and NDS, the National Design Specification for Wood Construction by AWC. The truss component designs are based on the specified loading and dimension information furnished by others to the Truss Design Engineer. The Truss Design Engineer has no duty to independently verify the accuracy or completeness of the information provided by others and may rely on that information without liability. The responsibility for verification of that information remains with others neither employed nor controlled by the Truss Design Engineer. The Truss Design Engineer's seal and signature on the attached drawings, or cover page listing these drawings, indicates acceptance of professional engineering responsibility solely for the truss component designs and not for the technical information furnished by others which technical information and consequences thereof remain their sole responsibility.

The suitability and use of these drawings for any particular structure is the responsibility of the Building Designer in accordance with ANSI/TPI 1 Chapter 2. The Building Designer is responsible for determining that the dimensions and loads for each truss component match those required by the plans and by the actual use of the individual component, and for ascertaining that the loads shown on the drawings meet or exceed applicable building code requirements and any additional factors required in the particular application. Truss components using metal connector plates with integral teeth shall not be placed in environments that will cause the moisture content of the wood in which plates are embedded to exceed 19% and/or cause corrosion of connector plates and other metal fasteners.

The Truss Design Engineer shall not be responsible for items beyond the specific scope of the agreed contracted work set forth herein, including but not limited to: verifying the dimensions of the truss component, calculation of any of the truss component design loads, inspection of the truss components before or after installation, the design of temporary or permanent bracing and their attachment required in the roof and/or floor systems, the design of diaphragms or shear walls, the design of load transfer connections to and from diaphragms and shear walls, the design of load transfer to the foundation, the design of connections for truss components to their bearing supports, the design of the bearing supports, installation of the truss components, observation of the truss component installation process, review of truss assembly procedures, sequencing of the truss component installation, construction means and methods, site and/or worker safety in the installation of the truss components and/or its connections.

This document may be a high-quality facsimile of the original engineering document which is a digitally signed electronic file with third party authentication. A wet or embossed seal copy of this engineering document is available upon request.

Temporary Lateral Restraint and Bracing:

Temporary lateral restraint and diagonal bracing shall be installed according to the provisions of BCSI chapters B1, B2, B7 and/or B10 (Building Component Safety Information, by TPI and SBCA), or as specified by the Building Designer or other Registered Design Professional. The required locations for lateral restraint and/or bracing depicted on these drawings are only for the permanent lateral support of the truss members to reduce buckling lengths, and do not apply to and may not be relied upon for the temporary stability of the truss components during their installation.

Permanent Lateral Restraint and Bracing:

The required locations for lateral restraint or bracing depicted on these drawings are for the permanent lateral support of the truss members to reduce buckling lengths. Permanent lateral support shall be installed according to the provisions of BCSI chapters B3, B7 and/or B10, or as specified by the Building Designer or other Registered Design Professional. These drawings do not depict or specify installation/erection bracing, wind bracing, portal bracing or similar building stability bracing which are parts of the overall building design to be specified, designed, and detailed by the Building Designer.

Connector Plate Information:

Alpine connector plates are made of ASTM A653 or ASTM A1063 galvanized steel with the following designations, gauges and grades: W=Wave, 20ga, grade 40; H=High Strength, 20ga, grade 60; S=Super Strength, 18ga, grade 60. Information on model code compliance is contained in the ICC Evaluation Service report ESR-1118, available on-line at www.icc-es.org.

Bearing Information:

The bearing area factor, C_b , is considered for the allowable capacity of solid sawn wood bearings supporting trusses that are located a minimum of 3" from the end of the lumber piece.

General Notes (continued)

Coated Lumber:

Coated lumber must be properly re-dried and maintained below 19% or less moisture level through all stages of construction and usage. Coated lumber has no adjustments to lumber properties. Coated lumber may be more brittle than uncoated lumber. Special handling care must be taken to prevent breakage during all handling activities. Refer to manufacturer literature, specifications, and code evaluation reports for restrictions, details, and requirements.

Fire Retardant Treated Lumber:

Fire retardant treated lumber must be properly re-dried and maintained below 19% or less moisture level through all stages of construction and usage. Fire retardant treated lumber may be more brittle than untreated lumber. Special handling care must be taken to prevent breakage during all handling activities.

Key to Terms:

Information provided on drawings reflects a summary of the pertinent information required for the truss design. Detailed information on load cases, reactions, member lengths, forces and members requiring permanent lateral support may be found in calculation sheets available upon written request.

BCDL = Bottom Chord standard design Dead Load in pounds per square foot.

BCLL = Bottom Chord standard design Live Load in pounds per square foot.

C = Coated lumber.

C-AT = AtTEK coated lumber.

C-FX = FX Lumber Guard coated lumber.

C -TE = TechWood 4400 coated lumber.

CL = Certified lumber.

Des Ld = total of TCLL, TCDL, BCLL and BCDL Design Load in pounds per square foot.

FRT = Fire Retardant Treated lumber.

FRT-BF = Boraflame Fire Retardant Treated lumber

FRT-DB = D-Blaze Fire Retardant Treated lumber.

FRT-DC = Dricon Fire Retardant Treated lumber.

FRT-FP = FirePRO Fire Retardant Treated lumber.

FRT-FL = FlamePRO Fire Retardant Treated lumber.

FRT-FT = FlameTech Fire Retardant Treated lumber.

FRT-ON = OnWood Fire Retardant Treated lumber.

FRT-PG = PYRO-GUARD Fire Retardant Treated lumber.

FRT-PR = ProWood Fire Retardant Treated lumber.

g = green lumber.

HORZ(LL) = maximum Horizontal panel point deflection due to Live Load, in inches.

HORZ(TL) = maximum Horizontal panel point long term deflection in inches, due to Total Load, including creep adjustment.

HPL = additional Horizontal Load added to a truss Piece in pounds per linear foot or pounds.

Ic = Incised lumber.

FJ = Finger Jointed lumber.

L/# = user specified divisor for limiting span/deflection ratio for evaluation of actual L/defl value.

L/defl = ratio of Length between bearings, in inches, divided by the vertical Deflection due to creep, in inches, at the referenced panel point. Reported as 999 if greater than or equal to 999.

Loc = Location, starting location of left end of bearing or panel point (joint) location of deflection.

Max BC CSI = Maximum bending and axial Combined Stress Index for Bottom Chords for all load cases.

Max TC CSI = Maximum bending and axial Combined Stress Index for Top Chords for all load cases.

Max Web CSI = Maximum bending and axial Combined Stress Index for Webs for all load cases.

NCBCLL = Non-Concurrent Bottom Chord design Live Load in pounds per square foot.

PL = additional Load applied at a user specified angle on a truss Piece in pounds per linear foot or pounds.

PLB = additional vertical load added to a Bottom chord Piece of a truss in pounds per linear foot or pounds

PLT = additional vertical load added to a Top chord Piece of a truss in pounds per linear foot or pounds.

PP = Panel Point.

R = maximum downward design Reaction, in pounds, from all specified gravity load cases, at the indicated location (Loc).

-R = maximum upward design Reaction, in pounds, from all specified gravity load cases, at the identified location (Loc).

Rh = maximum horizontal design Reaction in either direction, in pounds, from all specified gravity load cases, at the indicated location (Loc).

RL = maximum horizontal design Reaction in either direction, in pounds, from all specified non-gravity (wind or seismic) load cases, at the indicated location (Loc).

General Notes (continued)

Key to Terms (continued):

Rw = maximum downward design Reaction, in pounds, from all specified non-gravity (wind or seismic) load cases, at the identified location (Loc).

TCDL = Top Chord standard design Dead Load in pounds per square foot.

TCLL = Top Chord standard design Live Load in pounds per square foot.

U = maximum Upward design reaction, in pounds, from all specified non-gravity (wind or seismic) load cases, at the indicated location (Loc).

VERT(CL) = maximum Vertical panel point deflection in inches due to Live Load and Creep Component of Dead Load in inches.

VERT(CTL) = maximum Vertical panel point deflection ratios due to Live Load and Creep Component of Dead Load, and maximum long term Vertical panel point deflection in inches due to Total load, including creep adjustment.

VERT(LL) = maximum Vertical panel point deflection in inches due to Live Load.

VERT(TL) = maximum Vertical panel point long term deflection in inches due to Total load, including creep adjustment.

W = Width of non-hanger bearing, in inches.

Refer to ASCE-7 for Wind and Seismic abbreviations.

Uppercase Acronyms not explained above are as defined in TPI 1.

References:

1. AWC: American Wood Council; 222 Catoclin Circle SE, Suite 201; Leesburg, VA 20175; www.awc.org.
2. ICC: International Code Council; www.iccsafe.org.
3. Alpine, a division of ITW Building Components Group Inc.: 155 Harlem Ave, North Building, 4th Floor, Glenview, IL 60025; www.alpineitw.com.
4. TPI: Truss Plate Institute, 2670 Crain Highway, Suite 203, Waldorf, MD 20601; www.tpinst.org.
5. SBCA: Wood Truss Council of America, 6300 Enterprise Lane, Madison, WI 53719; www.sbcacomponents.com

SEQN: 430614 FROM: RFG	GABL Ply: 1 Qty: 1	Job Number: 26-3432 MOORE Truss Label: A01	Cust: R215 JRef: 1YH82150009 T29 DrwNo: 030.26.1736.43760 GA / WHK 01/30/2026
---------------------------	--------------------------	--	---

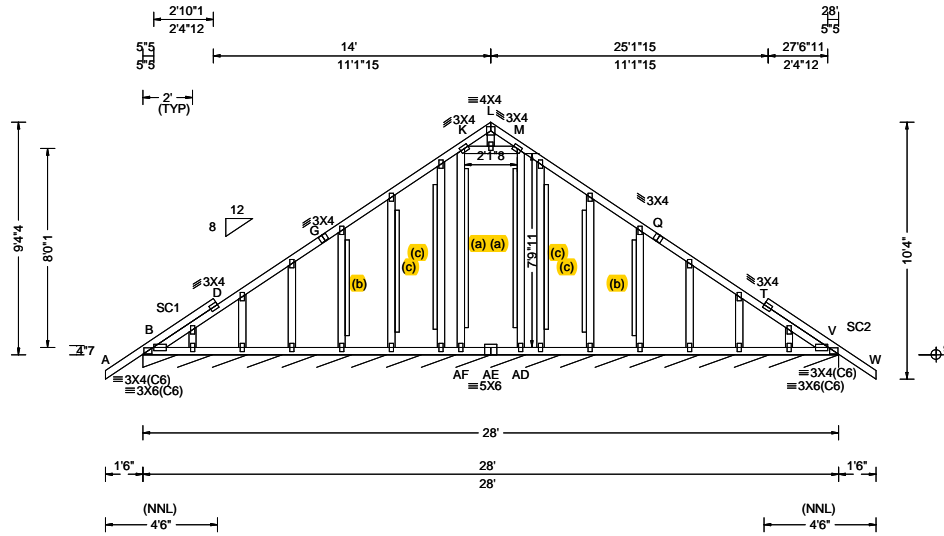

Loading Criteria (psf) TCCL: 20.00 TCCL: 10.00 BCLL: 0.00 BCDL: 10.00 Des Ld: 40.00 NCBCLL: 10.00 Soffit: 2.00 Load Duration: 1.25 Spacing: 24.0 "	Wind Criteria Wind Std: ASCE 7-22 Speed: 130 mph Enclosure: Enclosed Risk Category: II EXP: C Kzt: NA Mean Height: 15.00 ft TCCL: 5.0 psf BCDL: 5.0 psf MWFRS Parallel Dist: 0 to h/2 C&C Dist a: 3.00 ft Loc. from endwall: Any GCpi: 0.18 Wind Duration: 1.60	Snow Criteria (Pg,Pf in PSF) Pg: NA Ct: NA CAT: NA Pf: NA Ce: NA Lu: NA Cs: NA Snow Duration: NA Building Code: FBC 8th Ed. 2023 Res. TPI Std: 2014 Rep Fac: Yes FT/RT:20(0)/10(0) Plate Type(s): WAVE	Defl/CSI Criteria PP Deflection in loc L/defl L/# VERT(LL): 0.002 T 999 240 VERT(CL): 0.003 T 999 180 HORZ(LL): -0.001 T - - HORZ(TL): 0.006 I - - Creep Factor: 2.0 Max TC CSI: 0.216 Max BC CSI: 0.075 Max Web CSI: 0.963 VIEW Ver: 24.02.00D.0611.08	▲ Maximum Reactions (lbs), or *=PLF <table border="1"> <thead> <tr> <th colspan="2">Gravity</th> <th colspan="5">Non-Gravity</th> </tr> <tr> <th>Loc</th> <th>R+</th> <th>/R-</th> <th>/Rh</th> <th>/Rw</th> <th>/U</th> <th>/RL</th> </tr> </thead> <tbody> <tr> <td>V*</td> <td>91</td> <td>/-</td> <td>/-</td> <td>/47</td> <td>/15</td> <td>/9</td> </tr> </tbody> </table> Wind reactions based on MWFRS V Brg Wid = 336 Min Req = - Bearing B is a rigid surface. Members not listed have forces less than 375#	Gravity		Non-Gravity					Loc	R+	/R-	/Rh	/Rw	/U	/RL	V*	91	/-	/-	/47	/15	/9
Gravity		Non-Gravity																							
Loc	R+	/R-	/Rh	/Rw	/U	/RL																			
V*	91	/-	/-	/47	/15	/9																			

Lumber
 Top chord: 2x4 SP #2;
 Bot chord: 2x4 SP #2;
 Webs: 2x4 SP #3;
 Stack Chord: SC1 2x4 SP #2;
 Stack Chord: SC2 2x4 SP #2;

Plating Notes
 All plates are 2X4 except as noted.

Purlins
 In lieu of structural panels use purlins to brace TC @ 24" oc.

Wind
 Wind loads based on MWFRS with additional C&C member design.
 Wind loading based on both gable and hip roof types.
 Gable meets L/120 deflection criteria for wind load applied to face. Calculated deflection ratio is L/406.

Additional Notes
 Exposed portion of gable face shall be reinforced with sheathing and the wind pressures shall be transferred into lateral diaphragms. Connections and designs for diaphragms is the responsibility of the Building Designer in accordance with ANSI/TPI 1.
 Stacked top chord must NOT be notched or cut in area (NNL). Dropped top chord braced at 24" oc intervals. Attach stacked top chord (SC) to dropped top chord in notchable area using 3x4 tie-plates 24" oc. Center plate on stacked/dropped chord interface, plate length perpendicular to chord length. Splice top chord in notchable area using 3x6.
 The overall height of this truss excluding overhang is 9-4-4.

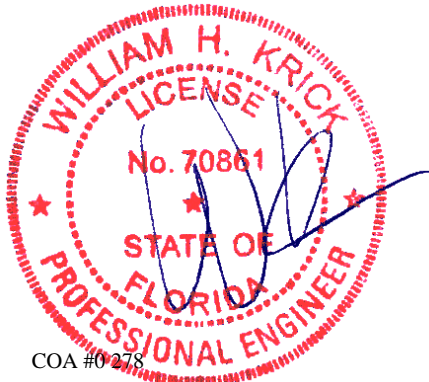

COA #0218
 02/02/2026
 Florida Certificate of Product Approval #FL 1999

****WARNING** READ AND FOLLOW ALL NOTES ON THIS DRAWING!**
****IMPORTANT** FURNISH THIS DRAWING TO ALL CONTRACTORS INCLUDING THE INSTALLERS**
 Trusses require extreme care in fabricating, handling, shipping, installing and bracing. Refer to and follow the latest edition of BCSI (Building Component Safety Information, by TPI and SBCA) for safety practices prior to performing these functions. Installers shall provide temporary bracing per BCSI. Unless noted otherwise, top chord shall have properly attached structural sheathing and bottom chord shall have a properly attached rigid ceiling. Locations shown on the CLR per BCSI sections B3, B7, or B10, as applicable. Apply plates to each face of truss and position as shown above and on the Joint Details, unless noted otherwise. Refer to drawings 160A-Z for standard plate positions. Refer to job's General Notes page for additional information.
 Alpine, a division of ITW Building Components Group Inc. shall not be responsible for any deviation from this drawing, any failure to build the truss in conformance with ANSI/TPI 1, or for handling, shipping, installation and bracing of trusses. A seal on this drawing or cover page listing this drawing, indicates acceptance of professional engineering responsibility solely for the design shown. The suitability and use of this drawing for any structure is the responsibility of the Building Designer per ANSI/TPI 1 Sec.2.
 For more information see these web sites: Alpine: alpineitw.com; TPI: tpinst.org; SBCA: sbccomponents.com; ICC: iccsafe.org; AWC: awc.org



SEQN: 430588 FROM: RFG	ATIC Ply: 1 Qty: 1	Job Number: 26-3432 MOORE Truss Label: A02	Cust: R 215 JRRef: 1YH82150009 T1 DrwNo: 030.26.1736.55843 GA / WHK 01/30/2026
---------------------------	--------------------------	--	--

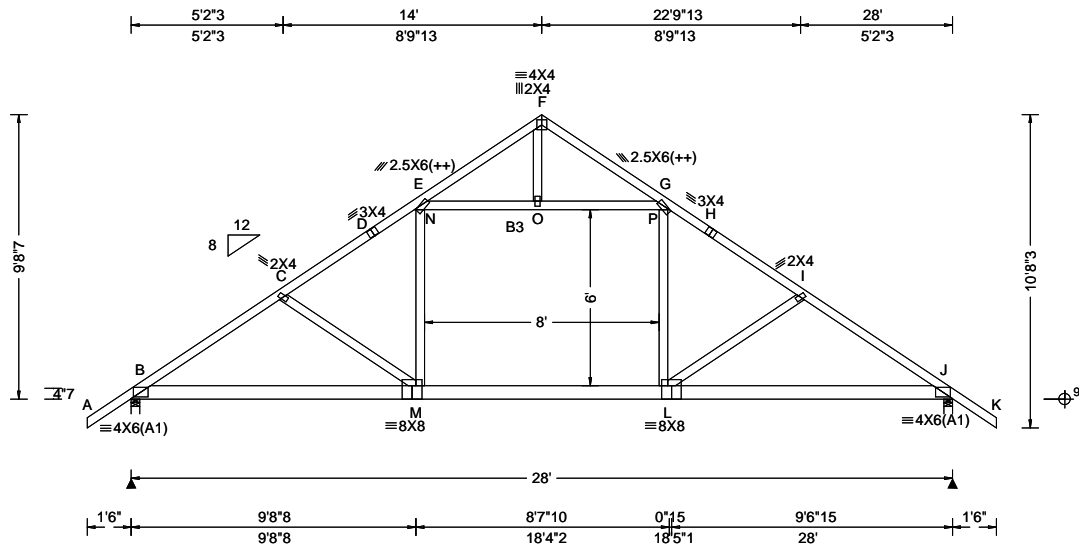

Loading Criteria (psf) TCCL: 20.00 TCCL: 10.00 BCLL: 0.00 BCDL: 10.00 Des Ld: 40.00 NCBCLL: 10.00 Soffit: 2.00 Load Duration: 1.25 Spacing: 24.0 "	Wind Criteria Wind Std: ASCE 7-22 Speed: 130 mph Enclosure: Enclosed Risk Category: II EXP: C Kzt: NA Mean Height: 15.00 ft TCCL: 5.0 psf BCDL: 5.0 psf MWFRS Parallel Dist: 0 to h/2 C&C Dist a: 3.00 ft Loc. from endwall: not in 4.50 ft GCp: 0.18 Wind Duration: 1.60	Snow Criteria (Pg,Pf in PSF) Pg: NA Ct: NA CAT: NA Pf: NA Ce: NA Lu: NA Cs: NA Snow Duration: NA Building Code: FBC 8th Ed. 2023 Res. TPI Std: 2014 Rep Fac: Yes FT/RT:20(0)/10(0) Plate Type(s): WAVE	Defl/CSI Criteria PP Deflection in loc L/defl L/# VERT(LL): 0.148 M 999 240 VERT(CL): 0.366 L 908 180 HORZ(LL): 0.075 E - - HORZ(TL): 0.185 E - - Creep Factor: 2.0 Max TC CSI: 0.463 Max BC CSI: 0.519 Max Web CSI: 0.383 VIEW Ver: 24.02.00D.0611.08	▲ Maximum Reactions (lbs) <table border="1"> <thead> <tr> <th rowspan="2">Loc</th> <th colspan="3">Gravity</th> <th colspan="3">Non-Gravity</th> </tr> <tr> <th>R+</th> <th>/R-</th> <th>/Rh</th> <th>/Rw</th> <th>/U</th> <th>/RL</th> </tr> </thead> <tbody> <tr> <td>B</td> <td>1890</td> <td>-</td> <td>-</td> <td>/703</td> <td>/212</td> <td>/278</td> </tr> <tr> <td>J</td> <td>1777</td> <td>-</td> <td>-</td> <td>/692</td> <td>/185</td> <td>-</td> </tr> </tbody> </table>						Loc	Gravity			Non-Gravity			R+	/R-	/Rh	/Rw	/U	/RL	B	1890	-	-	/703	/212	/278	J	1777	-	-	/692	/185	-
				Loc	Gravity			Non-Gravity																												
R+	/R-	/Rh	/Rw		/U	/RL																														
B	1890	-	-	/703	/212	/278																														
J	1777	-	-	/692	/185	-																														
Maximum Top Chord Forces Per Ply (lbs) <table border="1"> <thead> <tr> <th>Chords</th> <th>Tens.Comp.</th> <th>Chords</th> <th>Tens. Comp.</th> </tr> </thead> <tbody> <tr> <td>B - C</td> <td>351</td> <td>F - G</td> <td>133</td> </tr> <tr> <td>C - D</td> <td>313</td> <td>G - H</td> <td>330</td> </tr> <tr> <td>D - E</td> <td>324</td> <td>H - I</td> <td>319</td> </tr> <tr> <td>E - F</td> <td>135</td> <td>I - J</td> <td>359</td> </tr> </tbody> </table>				Chords	Tens.Comp.	Chords	Tens. Comp.	B - C	351	F - G	133	C - D	313	G - H	330	D - E	324	H - I	319	E - F	135	I - J	359													
Chords	Tens.Comp.	Chords	Tens. Comp.																																	
B - C	351	F - G	133																																	
C - D	313	G - H	330																																	
D - E	324	H - I	319																																	
E - F	135	I - J	359																																	

Lumber
 Top chord: 2x4 SP #2;
 Bot chord: 2x6 SP 2400f-2.0E; B3 2x4 SP #2;
 Webs: 2x4 SP #3;

Plating Notes
 (++) - This plate works for both joints covered.

Loading
 Attic room loading from 10-0-0 to 18-0-0: Live Load: 40 PSF. Dead Load: 10 PSF Ceiling: 10 PSF, Kneewalls: 10 PSF

Purlins
 Collar-tie braced with continuous lateral bracing at 24" oc. or rigid ceiling.

Wind
 Wind loads based on MWFRS with additional C&C member design.
 Wind loading based on both gable and hip roof types.

Additional Notes
 The overall height of this truss excluding overhang is 9-8-7.



COA #0 278

02/02/2026 Florida Certificate of Product Approval #FL 1999

****WARNING** READ AND FOLLOW ALL NOTES ON THIS DRAWING!**
****IMPORTANT** FURNISH THIS DRAWING TO ALL CONTRACTORS INCLUDING THE INSTALLERS**
 Trusses require extreme care in fabricating, handling, shipping, installing and bracing. Refer to and follow the latest edition of BCSI (Building Component Safety Information, by TPI and SBCA) for safety practices prior to performing these functions. Installers shall provide temporary bracing per BCSI. Unless noted otherwise, top chord shall have properly attached structural sheathing and bottom chord shall have a properly attached rigid ceiling. Locations shown for permanent lateral restraint of webs shall have continuous lateral restraint (CLR), installed with diagonal bracing installed on the CLR per BCSI sections B3, B7, or B10, as applicable. Apply plates to each face of truss and position as shown above and on the Joint Details, unless noted otherwise. Refer to drawings 160A-Z for standard plate positions. Refer to job's General Notes page for additional information.
 Alpine, a division of ITW Building Components Group Inc. shall not be responsible for any deviation from this drawing, any failure to build the truss in conformance with ANSI/TPI 1, or for handling, shipping, installation and bracing of trusses. A seal on this drawing or cover page listing this drawing, indicates acceptance of professional engineering responsibility solely for the design shown. The suitability and use of this drawing for any structure is the responsibility of the Building Designer per ANSI/TPI 1 Sec.2.
 For more information see these web sites: Alpine: alpineitw.com; TPI: tpinst.org; SBCA: sbcacomponents.com; ICC: iccsafe.org; AWC: awc.org



SEQN: 430590 FROM: RFG	ATIC Ply: 1 Qty: 4	Job Number: 26-3432 MOORE Truss Label: A03	Cust: R215 JRef: 1YH82150009 T30 DrwNo: 030.26.1736.59640 GA / WHK 01/30/2026
---------------------------	--------------------------	--	---

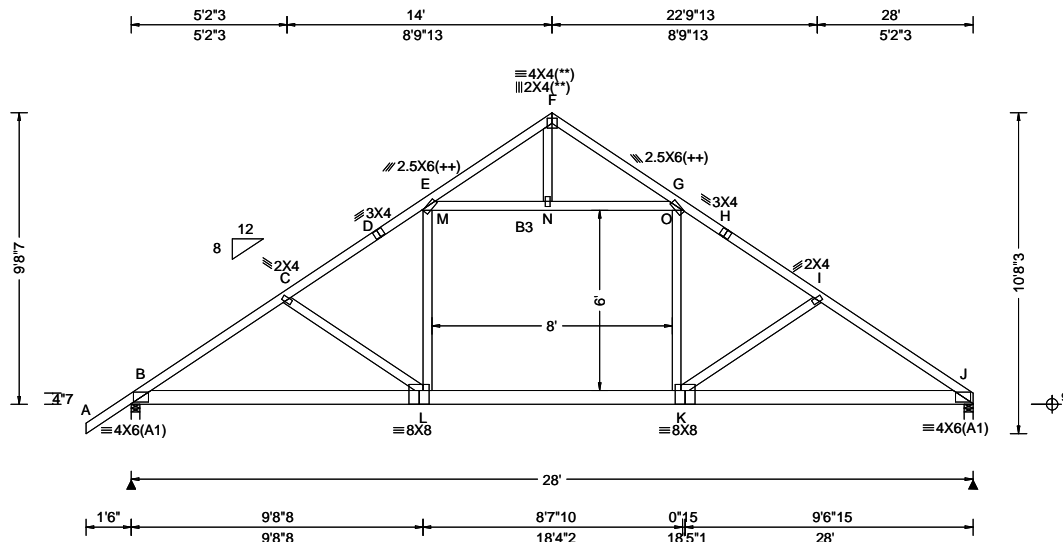

Loading Criteria (psf) TCLL: 20.00 TC DL: 10.00 BCLL: 0.00 BCDL: 10.00 Des Ld: 40.00 NCBCLL: 10.00 Soffit: 2.00 Load Duration: 1.25 Spacing: 24.0 "	Wind Criteria Wind Std: ASCE 7-22 Speed: 130 mph Enclosure: Enclosed Risk Category: II EXP: C Kzt: NA Mean Height: 15.00 ft TC DL: 5.0 psf BCDL: 5.0 psf MWFRS Parallel Dist: 0 to h/2 C&C Dist a: 3.00 ft Loc. from endwall: not in 4.50 ft GCp: 0.18 Wind Duration: 1.60	Snow Criteria (Pg,Pf in PSF) Pg: NA Ct: NA CAT: NA Pf: NA Ce: NA Lu: NA Cs: NA Snow Duration: NA Building Code: FBC 8th Ed. 2023 Res. TPI Std: 2014 Rep Fac: Yes FT/RT:20(0)/10(0) Plate Type(s): WAVE	Defl/CSI Criteria PP Deflection in loc L/defl L/# VERT(LL): 0.148 L 999 240 VERT(CL): 0.366 K 908 180 HORZ(LL): 0.075 E - - HORZ(TL): 0.185 E - - Creep Factor: 2.0 Max TC CSI: 0.463 Max BC CSI: 0.519 Max Web CSI: 0.383 VIEW Ver: 24.02.00D.0611.08	▲ Maximum Reactions (lbs) <table border="1"> <thead> <tr> <th rowspan="2">Loc</th> <th colspan="3">Gravity</th> <th colspan="3">Non-Gravity</th> </tr> <tr> <th>R+</th> <th>/R-</th> <th>/Rh</th> <th>/Rw</th> <th>/U</th> <th>/RL</th> </tr> </thead> <tbody> <tr> <td>B</td> <td>1890</td> <td>-</td> <td>-</td> <td>/703</td> <td>/212</td> <td>/278</td> </tr> <tr> <td>J</td> <td>1777</td> <td>-</td> <td>-</td> <td>/692</td> <td>/185</td> <td>-</td> </tr> </tbody> </table>						Loc	Gravity			Non-Gravity			R+	/R-	/Rh	/Rw	/U	/RL	B	1890	-	-	/703	/212	/278	J	1777	-	-	/692	/185	-																									
				Loc	Gravity			Non-Gravity																																																					
R+	/R-	/Rh	/Rw		/U	/RL																																																							
B	1890	-	-	/703	/212	/278																																																							
J	1777	-	-	/692	/185	-																																																							
Maximum Top Chord Forces Per Ply (lbs) <table border="1"> <thead> <tr> <th rowspan="2">Chords</th> <th colspan="2">Tens.Comp.</th> <th rowspan="2">Chords</th> <th colspan="2">Tens. Comp.</th> </tr> <tr> <th></th> <th></th> <th></th> <th></th> </tr> </thead> <tbody> <tr> <td>B - C</td> <td>351</td> <td>-2864</td> <td>F - G</td> <td>133</td> <td>-574</td> </tr> <tr> <td>C - D</td> <td>313</td> <td>-2616</td> <td>G - H</td> <td>330</td> <td>-2507</td> </tr> <tr> <td>D - E</td> <td>324</td> <td>-2505</td> <td>H - I</td> <td>319</td> <td>-2618</td> </tr> <tr> <td>E - F</td> <td>135</td> <td>-595</td> <td>I - J</td> <td>359</td> <td>-2869</td> </tr> </tbody> </table>				Chords	Tens.Comp.		Chords	Tens. Comp.						B - C	351	-2864	F - G	133	-574	C - D	313	-2616	G - H	330	-2507	D - E	324	-2505	H - I	319	-2618	E - F	135	-595	I - J	359	-2869	Maximum Bot Chord Forces Per Ply (lbs) <table border="1"> <thead> <tr> <th rowspan="2">Chords</th> <th colspan="2">Tens.Comp.</th> <th rowspan="2">Chords</th> <th colspan="2">Tens. Comp.</th> </tr> <tr> <th></th> <th></th> <th></th> <th></th> </tr> </thead> <tbody> <tr> <td>B - L</td> <td>2312</td> <td>-212</td> <td>K - J</td> <td>2321</td> <td>-217</td> </tr> <tr> <td>L - K</td> <td>2088</td> <td>-76</td> <td></td> <td></td> <td></td> </tr> </tbody> </table>		Chords	Tens.Comp.		Chords	Tens. Comp.						B - L	2312	-212	K - J	2321	-217	L - K	2088	-76			
Chords	Tens.Comp.		Chords		Tens. Comp.																																																								
B - C	351	-2864	F - G	133	-574																																																								
C - D	313	-2616	G - H	330	-2507																																																								
D - E	324	-2505	H - I	319	-2618																																																								
E - F	135	-595	I - J	359	-2869																																																								
Chords	Tens.Comp.		Chords	Tens. Comp.																																																									
B - L	2312	-212	K - J	2321	-217																																																								
L - K	2088	-76																																																											

Lumber
 Top chord: 2x4 SP #2;
 Bot chord: 2x6 SP 2400f-2.0E; B3 2x4 SP #2;
 Webs: 2x4 SP #3;

Plating Notes
 (++) - This plate works for both joints covered.
 (**) 2 plate(s) require special positioning. Refer to scaled plate plot details for special positioning requirements.

Loading
 Attic room loading from 10-0-0 to 18-0-0: Live Load: 40 PSF. Dead Load: 10 PSF Ceiling: 10 PSF, Kneewalls: 10 PSF

Purlins
 Collar-tie braced with continuous lateral bracing at 24" oc. or rigid ceiling.

Wind
 Wind loads based on MWFRS with additional C&C member design.
 Wind loading based on both gable and hip roof types.

Additional Notes
 The overall height of this truss excluding overhang is 9-8-7.



COA #0278
 02/02/2026
 Florida Certificate of Product Approval #FL 1999

****WARNING** READ AND FOLLOW ALL NOTES ON THIS DRAWING!**
****IMPORTANT** FURNISH THIS DRAWING TO ALL CONTRACTORS INCLUDING THE INSTALLERS**
 Trusses require extreme care in fabricating, handling, shipping, installing and bracing. Refer to and follow the latest edition of BCSI (Building Component Safety Information, by TPI and SBCA) for safety practices prior to performing these functions. Installers shall provide temporary bracing per BCSI. Unless noted otherwise, top chord shall have properly attached structural sheathing and bottom chord shall have a properly attached rigid ceiling. Locations shown for permanent lateral restraint of webs shall have continuous lateral restraint (CLR), installed with diagonal bracing installed on the CLR per BCSI sections B3, B7, or B10, as applicable. Apply plates to each face of truss and position as shown above and on the Joint Details, unless noted otherwise. Refer to drawings 160A-Z for standard plate positions. Refer to job's General Notes page for additional information.
 Alpine, a division of ITW Building Components Group Inc. shall not be responsible for any deviation from this drawing, any failure to build the truss in conformance with ANSI/TPI 1, or for handling, shipping, installation and bracing of trusses. A seal on this drawing or cover page listing this drawing, indicates acceptance of professional engineering responsibility solely for the design shown. The suitability and use of this drawing for any structure is the responsibility of the Building Designer per ANSI/TPI 1 Sec.2.
 For more information see these web sites: Alpine: alpineitw.com; TPI: tpinst.org; SBCA: sbccomponents.com; ICC: iccsafe.org; AWC: awc.org



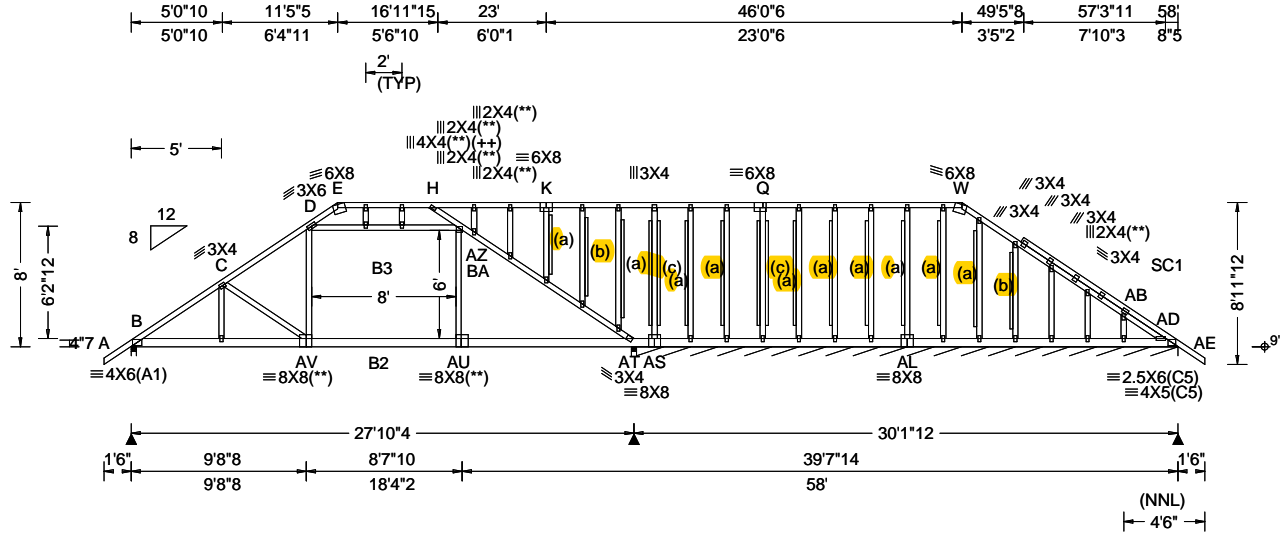

Loading Criteria (psf) TCLL: 20.00 TCDL: 10.00 BCLL: 0.00 BCDL: 10.00 Des Ld: 40.00 NCBCLL: 10.00 Soffit: 2.00 Load Duration: 1.25 Spacing: 24.0 "	Wind Criteria Wind Std: ASCE 7-22 Speed: 130 mph Enclosure: Enclosed Risk Category: II EXP: C Kzt: NA Mean Height: 18.54 ft TCDL: 5.0 psf BCDL: 5.0 psf MWFRS Parallel Dist: 0 to h/2 C&C Dist a: 5.80 ft Loc. from endwall: not in 6.50 ft GCp: 0.18 Wind Duration: 1.60	Snow Criteria (Pg,Pf in PSF) Pg: NA Ct: NA CAT: NA Pf: NA Ce: NA Lu: NA Cs: NA Snow Duration: NA Building Code: FBC 8th Ed. 2023 Res. TPI Std: 2014 Rep Fac: Varies by Ld Case FT/RT:20(0)/10(0) Plate Type(s): WAVE	Defl/CSI Criteria PP Deflection in loc L/defl L/# VERT(LL): 0.166 K 999 240 VERT(CL): 0.337 K 987 180 HORZ(LL): -0.067 BD - - HORZ(TL): 0.136 BD - - Creep Factor: 2.0 Max TC CSI: 0.846 Max BC CSI: 0.833 Max Web CSI: 0.990 VIEW Ver: 24.02.00D.0611.08	▲ Maximum Reactions (lbs), or *=PLF Gravity Non-Gravity Loc R+ / R- / Rh / Rw / U / RL B 1846 - / - / - / - /238 -/ AT 2514 - / 0 / - / - /306 /0 AD*224 - / - / - / - /56 -/ AS - /-380 Wind reactions based on MWFRS B Brg Wid = 3.5 Min Req = 2.2 (Truss) AT Brg Wid = 3.5 Min Req = 2.6 (Truss) AD Brg Wid = 359 Min Req = - Bearings B, AT, & AT are a rigid surface. Members not listed have forces less than 375# Maximum Top Chord Forces Per Ply (lbs) Chords Tens.Comp. Chords Tens. Comp. B - C 309 -2724 D - E 87 - 615 C - D 258 -2545 E - H 50 - 508 Maximum Bot Chord Forces Per Ply (lbs) Chords Tens.Comp. Chords Tens. Comp. B -AV 2205 -233 AU-AT 2012 - 188 AV-AU 2012 -188 Maximum Web Forces Per Ply (lbs) Webs Tens.Comp. Webs Tens. Comp. AV - D 904 0 AZ-AU 750 0 D -AZ 139 -1511 BA-AT 349 -2787 H -BA 153 -821
--	---	--	--	--

Lumber
Top chord: 2x4 SP #2;
Bot chord: 2x6 SP #2; B2 2x6 SP 2400f-2.0E;
B3 2x4 SP #2;
Webs: 2x4 SP #3;
Stack Chord: SC1 2x4 SP #2;

Blocking
Blocking reinforcement required to prevent buckling of members over the bearings:
Bearing 2 located at 27.7' (blocking >= 39.36" if used)

Plating Notes
All plates are 2X4 except as noted.
(++) - This plate works for both joints covered.
(**) 8 plate(s) require special positioning. Refer to scaled plate plot details for special positioning requirements.

Loading
Gable end supports 8" max rake overhang. Top chord must not be cut or notched.
Attic room loading from 10-0-0 to 18-0-0: Live Load: 40 PSF. Dead Load: 10 PSF Ceiling: 10 PSF, Kneewalls: 10 PSF

Purlins
In lieu of structural panels use purlins to brace all flat TC @ 24" oc.
Collar-tie braced with continuous lateral bracing at 24" oc. or rigid ceiling.

Wind
Wind loads and reactions based on MWFRS.
Wind loading based on both gable and hip roof types.
Gable meets L/120 deflection criteria for wind load applied to face. Calculated deflection ratio is L/208.



COA #0278
02/02/2026
Florida Certificate of Product Approval #FL 1999

****WARNING** READ AND FOLLOW ALL NOTES ON THIS DRAWING!**
****IMPORTANT** FURNISH THIS DRAWING TO ALL CONTRACTORS INCLUDING THE INSTALLERS**
Trusses require extreme care in fabricating, handling, shipping, installing and bracing. Refer to and follow the latest edition of BCSI (Building Component Safety Information, by TPI and SBCA) for safety practices prior to performing these functions. Installers shall provide temporary bracing per BCSI. Unless noted otherwise, top chord shall have properly attached structural sheathing and bottom chord shall have a properly attached rigid ceiling. Locations shown for permanent lateral restraint of webs shall have continuous lateral restraint (CLR), installed with diagonal bracing installed on the CLR per BCSI sections B3, B7, or B10, as applicable. Apply plates to each face of truss and position as shown above and on the Joint Details, unless noted otherwise. Refer to drawings 160A-Z for standard plate positions. Refer to job's General Notes page for additional information.
Alpine, a division of ITW Building Components Group Inc. shall not be responsible for any deviation from this drawing, any failure to build the truss in conformance with ANSI/TPI 1, or for handling, shipping, installation and bracing of trusses. A seal on this drawing or cover page listing this drawing, indicates acceptance of professional engineering responsibility solely for the design shown. The suitability and use of this drawing for any structure is the responsibility of the Building Designer per ANSI/TPI 1 Sec.2.
For more information see these web sites: Alpine: alpineitw.com; TPI: tpinst.org; SBCA: sbcacomponents.com; ICC: iccsafe.org; AWC: awc.org



SEQN: 430641	GABL	Ply: 1	Job Number: 26-3432	Cust: R215 JRef: 1YH82150009 T31
FROM: RFG		Qty: 1	MOORE	DrwNo: 030.26.1737.20477
Page 2 of 2			Truss Label: A04	GA / WHK 01/30/2026

Gable Reinforcement

- (a) 2x6 "L" reinforcement. Any species and grade. 80% length of web member. Attach with 10d (0.131"x3",min.) nails @ 2" oc at each end for the first 18" and then 4" oc for the remainder.
- (b) 2x4 "L" reinforcement. Any species and grade. 80% length of web member. Attach with 10d (0.131"x3",min.) nails @ 2" oc at each end for the first 18" and then 4" oc for the remainder.
- (c) Two 2x6 "L" reinforcements. Any species and grade. 80% length of web member. Attach one to each narrow face of web with 10d (0.131"x3",min.) nails @ 2" oc at each end for the first 18" and then 6" oc for the remainder.

Additional Notes

Exposed portion of gable face shall be reinforced with sheathing and the wind pressures shall be transferred into lateral diaphragms. Connections and designs for diaphragms is the responsibility of the Building Designer in accordance with ANSI/TPI 1.

Stacked top chord must NOT be notched or cut in area (NNL). Dropped top chord braced at 24" oc intervals. Attach stacked top chord (SC) to dropped top chord in notchable area using 3x4 tie-plates 24" oc. Center plate on stacked/dropped chord interface, plate length perpendicular to chord length. Splice top chord in notchable area using 3x6.

WARNING: Furnish a copy of this DWG to the installation contractor. Special care must be taken during handling, shipping and installation of trusses. See "WARNING" note below.

The overall height of this truss excluding overhang is 8-0-0.

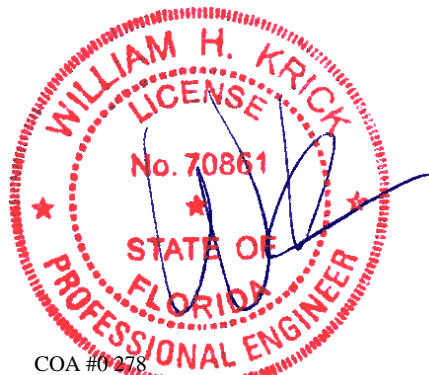

COA #0278

02/02/2026 Florida Certificate of Product Approval #FL 1999

****WARNING** READ AND FOLLOW ALL NOTES ON THIS DRAWING!**
****IMPORTANT** FURNISH THIS DRAWING TO ALL CONTRACTORS INCLUDING THE INSTALLERS**
 Trusses require extreme care in fabricating, handling, shipping, installing and bracing. Refer to and follow the latest edition of BCSI (Building Component Safety Information, by TPI and SBCA) for safety practices prior to performing these functions. Installers shall provide temporary bracing per BCSI. Unless noted otherwise, top chord shall have properly attached structural sheathing and bottom chord shall have a properly attached rigid ceiling. Locations shown for permanent lateral restraint of webs shall have continuous lateral restraint (CLR), installed with diagonal bracing installed on the CLR per BCSI sections B3, B7, or B10, as applicable. Apply plates to each face of truss and position as shown above and on the Joint Details, unless noted otherwise. Refer to drawings 160A-Z for standard plate positions. Refer to job's General Notes page for additional information.
 Alpine, a division of ITW Building Components Group Inc. shall not be responsible for any deviation from this drawing, any failure to build the truss in conformance with ANSI/TPI 1, or for handling, shipping, installation and bracing of trusses. A seal on this drawing or cover page listing this drawing, indicates acceptance of professional engineering responsibility solely for the design shown. The suitability and use of this drawing for any structure is the responsibility of the Building Designer per ANSI/TPI 1 Sec.2.
 For more information see these web sites: Alpine: alpineitw.com; TPI: tpinst.org; SBCA: sbcacomponents.com; ICC: iccsafe.org; AWC: awc.org



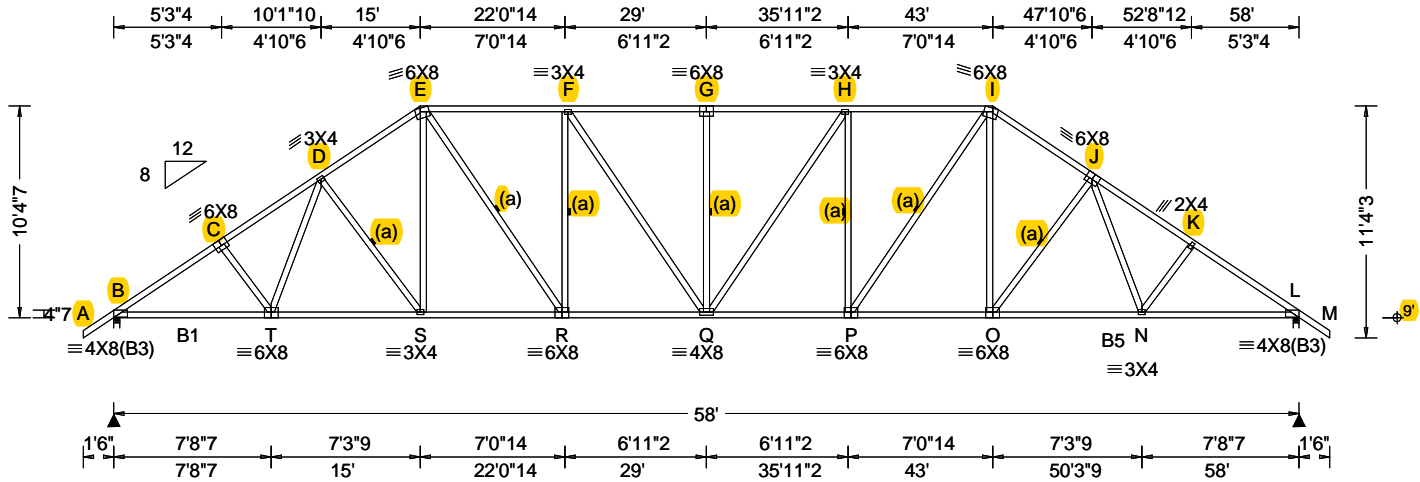

Loading Criteria (psf) TCLL: 20.00 TCDL: 10.00 BCLL: 0.00 BCDL: 10.00 Des Ld: 40.00 NCBCLL: 10.00 Soffit: 2.00 Load Duration: 1.25 Spacing: 24.0 "	Wind Criteria Wind Std: ASCE 7-22 Speed: 130 mph Enclosure: Enclosed Risk Category: II EXP: C Kzt: NA Mean Height: 15.00 ft TCDL: 5.0 psf BCDL: 5.0 psf MWFRS Parallel Dist: h to 2h C&C Dist a: 5.80 ft Loc. from endwall: not in 13.00 ft GCp: 0.18 Wind Duration: 1.60	Snow Criteria (Pg,Pf in PSF) Pg: NA Ct: NA CAT: NA Pf: NA Ce: NA Lu: NA Cs: NA Snow Duration: NA Building Code: FBC 8th Ed. 2023 Res. TPI Std: 2014 Rep Fac: Yes FT/RT:20(0)/10(0) Plate Type(s): WAVE	Defl/CSI Criteria PP Deflection in loc L/defl L/# VERT(LL): 0.320 G 999 240 VERT(CL): 0.665 G 999 180 HORZ(LL): 0.126 L - - HORZ(TL): 0.262 L - - Creep Factor: 2.0 Max TC CSI: 0.912 Max BC CSI: 0.845 Max Web CSI: 0.519 VIEW Ver: 24.02.00D.0611.08	▲ Maximum Reactions (lbs) Gravity Non-Gravity Loc R+ / R- / Rh / Rw / U / RL B 2540 /- /- /1442 /125 /314 L 2540 /- /- /1442 /125 /- Wind reactions based on MWFRS B Brg Wid = 3.5 Min Req = 2.1 (Truss) L Brg Wid = 3.5 Min Req = 2.1 (Truss) Bearings B & L are a rigid surface. Members not listed have forces less than 375# Maximum Top Chord Forces Per Ply (lbs) Chords Tens.Comp. Chords Tens. Comp. B - C 1107 -3911 G - H 1229 -3490 C - D 1134 -3731 H - I 1196 -3282 D - E 1126 -3302 I - J 1126 -3301 E - F 1195 -3282 J - K 1133 -3730 F - G 1229 -3490 K - L 1106 -3910
--	---	--	---	--

Lumber
Top chord: 2x4 SP #2;
Bot chord: 2x4 SP #2; B1,B5 2x4 SP M-31;
Webs: 2x4 SP #3;

Bracing
(a) Continuous lateral restraint equally spaced on member.

Purlins
In lieu of structural panels use purlins to brace all flat TC @ 24" oc.

Wind
Wind loads based on MWFRS with additional C&C member design.
Wind loading based on both gable and hip roof types.

Additional Notes
WARNING: Furnish a copy of this DWG to the installation contractor. Special care must be taken during handling, shipping and installation of trusses. See "WARNING" note below.
The overall height of this truss excluding overhang is 10-4-7.

Maximum Bot Chord Forces Per Ply (lbs)			
Chords	Tens.Comp.	Chords	Tens. Comp.
B - T	3161 -786	Q - P	3303 -776
T - S	2941 -689	P - O	2676 -564
S - R	2677 -583	O - N	2939 -669
R - Q	3303 -795	N - L	3161 -766
Maximum Web Forces Per Ply (lbs)			
Webs	Tens.Comp.	Webs	Tens. Comp.
D - S	204 -447	H - P	372 -744
E - S	550 -98	P - I	1068 -366
E - R	1067 -367	I - O	548 -98
R - F	372 -744	O - J	202 -445
G - Q	215 -412		



COA #0278

02/02/2026 Florida Certificate of Product Approval #FL 1999

****WARNING** READ AND FOLLOW ALL NOTES ON THIS DRAWING!**
****IMPORTANT** FURNISH THIS DRAWING TO ALL CONTRACTORS INCLUDING THE INSTALLERS**
Trusses require extreme care in fabricating, handling, shipping, installing and bracing. Refer to and follow the latest edition of BCSI (Building Component Safety Information, by TPI and SBCA) for safety practices prior to performing these functions. Installers shall provide temporary bracing per BCSI. Unless noted otherwise, top chord shall have properly attached structural sheathing and bottom chord shall have a properly attached rigid ceiling. Locations shown for permanent lateral restraint of webs shall have continuous lateral restraint (CLR), installed with diagonal bracing installed on the CLR per BCSI sections B3, B7, or B10, as applicable. Apply plates to each face of truss and position as shown above and on the Joint Details, unless noted otherwise. Refer to drawings 160A-Z for standard plate positions. Refer to job's General Notes page for additional information.
Alpine, a division of ITW Building Components Group Inc. shall not be responsible for any deviation from this drawing, any failure to build the truss in conformance with ANSI/TPI 1, or for handling, shipping, installation and bracing of trusses. A seal on this drawing or cover page listing this drawing, indicates acceptance of professional engineering responsibility solely for the design shown. The suitability and use of this drawing for any structure is the responsibility of the Building Designer per ANSI/TPI 1 Sec.2.
For more information see these web sites: Alpine: alpineitw.com; TPI: tpinst.org; SBCA: sbccomponents.com; ICC: iccsafe.org; AWC: awc.org



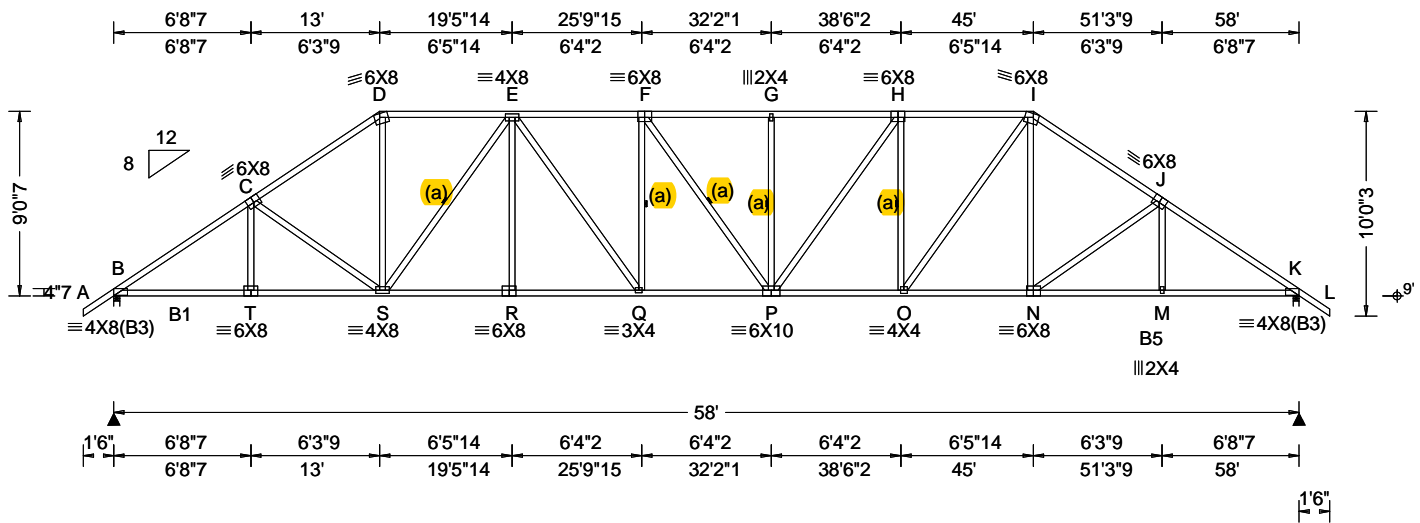

Loading Criteria (psf) TCLL: 20.00 TCDL: 10.00 BCLL: 0.00 BCDL: 10.00 Des Ld: 40.00 NCBCLL: 10.00 Soffit: 2.00 Load Duration: 1.25 Spacing: 24.0 "	Wind Criteria Wind Std: ASCE 7-22 Speed: 130 mph Enclosure: Enclosed Risk Category: II EXP: C Kzt: NA Mean Height: 15.00 ft TCDL: 5.0 psf BCDL: 5.0 psf MWFRS Parallel Dist: h to 2h C&C Dist a: 5.80 ft Loc. from endwall: not in 13.00 ft GCp: 0.18 Wind Duration: 1.60	Snow Criteria (Pg,Pf in PSF) Pg: NA Ct: NA CAT: NA Pf: NA Ce: NA Lu: NA Cs: NA Snow Duration: NA Building Code: FBC 8th Ed. 2023 Res. TPI Std: 2014 Rep Fac: Yes FT/RT:20(0)/10(0) Plate Type(s): WAVE	Defl/CSI Criteria PP Deflection in loc L/defl L/# VERT(LL): 0.371 G 999 240 VERT(CL): 0.772 G 896 180 HORZ(LL): 0.139 K - - HORZ(TL): 0.289 K - - Creep Factor: 2.0 Max TC CSI: 0.783 Max BC CSI: 0.946 Max Web CSI: 0.982 VIEW Ver: 24.02.00D.0611.08	▲ Maximum Reactions (lbs) Gravity Non-Gravity Loc R+ / R- / Rh / Rw / U / RL B 2540 /- /- /1420 /141 /272 K 2540 /- /- /1420 /141 /- Wind reactions based on MWFRS B Brg Wid = 3.5 Min Req = 2.1 (Truss) K Brg Wid = 3.5 Min Req = 2.1 (Truss) Bearings B & K are a rigid surface. Members not listed have forces less than 375# Maximum Top Chord Forces Per Ply (lbs) Chords Tens.Comp. Chords Tens. Comp. B - C 1131 -3890 G - H 1377 -3969 C - D 1157 -3466 H - I 1282 -3566 D - E 1025 -2816 I - J 1159 -3472 E - F 1373 -3960 J - K 1130 -3888 F - G 1377 -3969
--	---	--	---	---

Lumber
Top chord: 2x4 SP #2;
Bot chord: 2x4 SP #2; B1,B5 2x4 SP M-31;
Webs: 2x4 SP #3;

Bracing
(a) Continuous lateral restraint equally spaced on member.

Purlins
In lieu of structural panels use purlins to brace all flat TC @ 24" oc.

Wind
Wind loads based on MWFRS with additional C&C member design.
Wind loading based on both gable and hip roof types.

Additional Notes
WARNING: Furnish a copy of this DWG to the installation contractor. Special care must be taken during handling, shipping and installation of trusses. See "WARNING" note below.
The overall height of this truss excluding overhang is 9'-0".

Maximum Bot Chord Forces Per Ply (lbs)			
Chords	Tens.Comp.	Chords	Tens. Comp.
B - T	3132 -789	P - O	3597 -913
T - S	3131 -790	O - N	2796 -645
S - R	3585 -929	N - M	3130 -770
R - Q	3585 -929	M - K	3131 -769
Q - P	3973 -1015		
Maximum Web Forces Per Ply (lbs)			
Webs	Tens.Comp.	Webs	Tens. Comp.
C - S	180 -418	P - H	644 -232
D - S	1451 -403	H - O	425 -933
S - E	455 -1311	O - I	1309 -444
E - Q	648 -231	I - N	449 -47
Q - F	252 -399	N - J	178 -413
G - P	211 -392		

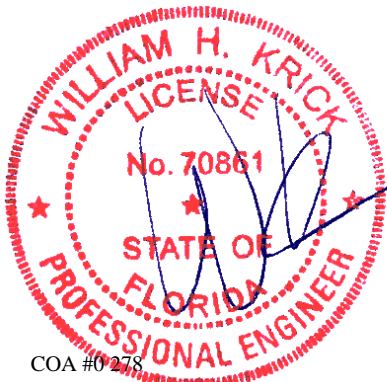

COA #0278
02/02/2026
Florida Certificate of Product Approval #FL 1999

****WARNING** READ AND FOLLOW ALL NOTES ON THIS DRAWING!**
****IMPORTANT** FURNISH THIS DRAWING TO ALL CONTRACTORS INCLUDING THE INSTALLERS**
Trusses require extreme care in fabricating, handling, shipping, installing and bracing. Refer to and follow the latest edition of BCSI (Building Component Safety Information, by TPI and SBCA) for safety practices prior to performing these functions. Installers shall provide temporary bracing per BCSI. Unless noted otherwise, top chord shall have properly attached structural sheathing and bottom chord shall have a properly attached rigid ceiling. Locations shown for permanent lateral restraint of webs shall have continuous lateral restraint (CLR), installed with diagonal bracing installed on the CLR per BCSI sections B3, B7, or B10, as applicable. Apply plates to each face of truss and position as shown above and on the Joint Details, unless noted otherwise. Refer to drawings 160A-Z for standard plate positions. Refer to job's General Notes page for additional information.
Alpine, a division of ITW Building Components Group Inc. shall not be responsible for any deviation from this drawing, any failure to build the truss in conformance with ANSI/TPI 1, or for handling, shipping, installation and bracing of trusses. A seal on this drawing or cover page listing this drawing, indicates acceptance of professional engineering responsibility solely for the design shown. The suitability and use of this drawing for any structure is the responsibility of the Building Designer per ANSI/TPI 1 Sec.2.
For more information see these web sites: Alpine: alpineitw.com; TPI: tpinst.org; SBCA: sbcacomponents.com; ICC: iccsafe.org; AWC: awc.org



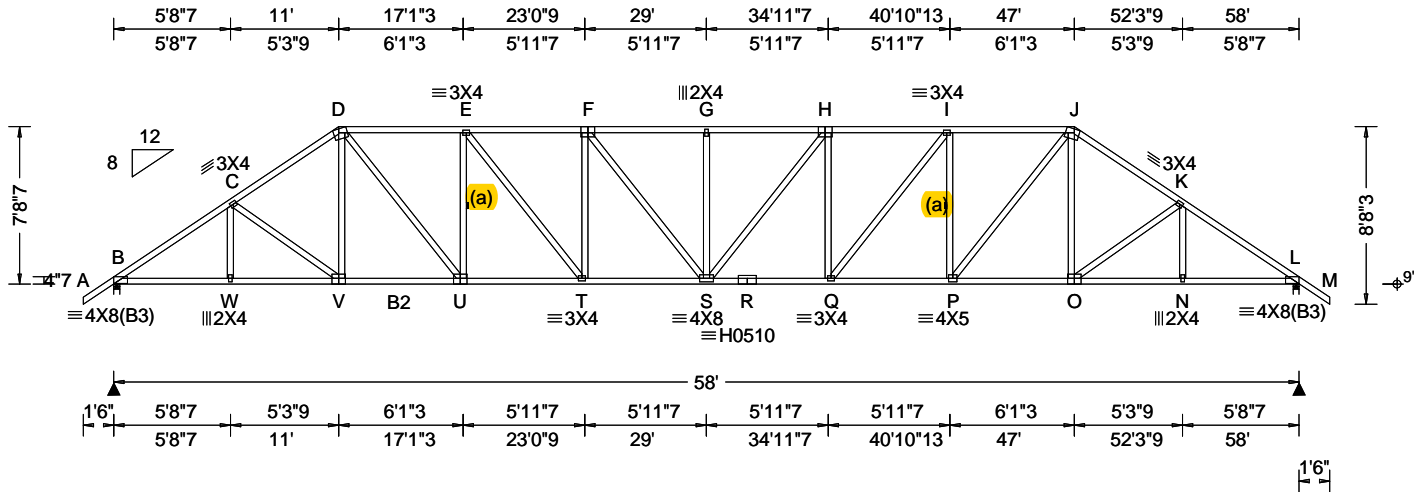

Loading Criteria (psf) TCLL: 20.00 TCDL: 10.00 BCLL: 0.00 BCDL: 10.00 Des Ld: 40.00 NCBCLL: 10.00 Soffit: 2.00 Load Duration: 1.25 Spacing: 24.0 "	Wind Criteria Wind Std: ASCE 7-22 Speed: 130 mph Enclosure: Enclosed Risk Category: II EXP: C Kzt: NA Mean Height: 15.00 ft TCDL: 5.0 psf BCDL: 5.0 psf MWFRS Parallel Dist: h to 2h C&C Dist a: 5.80 ft Loc. from endwall: not in 13.00 ft GCpi: 0.18 Wind Duration: 1.60	Snow Criteria (Pg,Pf in PSF) Pg: NA Ct: NA CAT: NA Pf: NA Ce: NA Lu: NA Cs: NA Snow Duration: NA Building Code: FBC 8th Ed. 2023 Res. TPI Std: 2014 Rep Fac: Yes FT/RT:20(0)/10(0) Plate Type(s): WAVE, HS	Defl/CSI Criteria PP Deflection in loc L/defl L/# VERT(LL): 0.434 G 999 240 VERT(CL): 0.904 G 765 180 HORZ(LL): 0.124 D - - HORZ(TL): 0.258 D - - Creep Factor: 2.0 Max TC CSI: 0.841 Max BC CSI: 0.732 Max Web CSI: 0.919 VIEW Ver: 24.02.00D.0611.08	▲ Maximum Reactions (lbs) Gravity Loc R+ / R- / Rh / Rw / U / RL Non-Gravity B 2540 - / - / 1395 / 154 / 231 L 2540 - / - / 1395 / 154 - Wind reactions based on MWFRS B Brg Wid = 3.5 Min Req = 2.1 (Truss) L Brg Wid = 3.5 Min Req = 2.1 (Truss) Bearings B & L are a rigid surface. Members not listed have forces less than 375# Maximum Top Chord Forces Per Ply (lbs) Chords Tens.Comp. Chords Tens. Comp. B - C 1168 -3895 G - H 1584 -4735 C - D 1204 -3584 H - I 1545 -4518 D - E 1389 -3910 I - J 1389 -3910 E - F 1544 -4518 J - K 1205 -3584 F - G 1584 -4735 K - L 1168 -3895
--	--	--	---	---

Lumber
Top chord: 2x4 SP #2;
Bot chord: 2x4 SP M-31; B2 2x4 SP #2;
Webs: 2x4 SP #3;

Bracing
(a) Continuous lateral restraint equally spaced on member.

Plating Notes
All plates are 6X8 except as noted.

Purlins
In lieu of structural panels use purlins to brace all flat TC @ 24" oc.

Wind
Wind loads based on MWFRS with additional C&C member design.
Wind loading based on both gable and hip roof types.

Additional Notes
WARNING: Furnish a copy of this DWG to the installation contractor. Special care must be taken during handling, shipping and installation of trusses. See "WARNING" note below.
The overall height of this truss excluding overhang is 7-8-7.

Maximum Bot Chord Forces Per Ply (lbs)

Chords	Tens.Comp.	Chords	Tens. Comp.
B - W	3145 -831	R - Q	4542 -1215
W - V	3145 -832	Q - P	3954 -1073
V - U	2908 -740	P - O	2908 -721
U - T	3954 -1092	O - N	3144 -810
T - S	4542 -1237	N - L	3145 -809
S - R	4542 -1215		

Maximum Web Forces Per Ply (lbs)

Webs	Tens.Comp.	Webs	Tens. Comp.
D - V	380 -36	H - Q	302 -617
D - U	1599 -540	Q - I	928 -306
U - E	483 -1132	I - P	483 -1131
E - T	928 -305	P - J	1598 -539
T - F	302 -617	J - O	379 -37



COA #0278
02/02/2026
Florida Certificate of Product Approval #FL 1999

****WARNING** READ AND FOLLOW ALL NOTES ON THIS DRAWING!**
****IMPORTANT** FURNISH THIS DRAWING TO ALL CONTRACTORS INCLUDING THE INSTALLERS**
Trusses require extreme care in fabricating, handling, shipping, installing and bracing. Refer to and follow the latest edition of BCSI (Building Component Safety Information, by TPI and SBCA) for safety practices prior to performing these functions. Installers shall provide temporary bracing per BCSI. Unless noted otherwise, top chord shall have properly attached structural sheathing and bottom chord shall have a properly attached rigid ceiling. Locations shown for permanent lateral restraint of webs shall have continuous lateral restraint (CLR), installed with diagonal bracing installed on the CLR per BCSI sections B3, B7, or B10, as applicable. Apply plates to each face of truss and position as shown above and on the Joint Details, unless noted otherwise. Refer to drawings 160A-Z for standard plate positions. Refer to job's General Notes page for additional information.
Alpine, a division of ITW Building Components Group Inc. shall not be responsible for any deviation from this drawing, any failure to build the truss in conformance with ANSI/TPI 1, or for handling, shipping, installation and bracing of trusses. A seal on this drawing or cover page listing this drawing, indicates acceptance of professional engineering responsibility solely for the design shown. The suitability and use of this drawing for any structure is the responsibility of the Building Designer per ANSI/TPI 1 Sec.2.
For more information see these web sites: Alpine: alpineitw.com; TPI: tpinst.org; SBCA: sbccomponents.com; ICC: iccsafe.org; AWC: awc.org



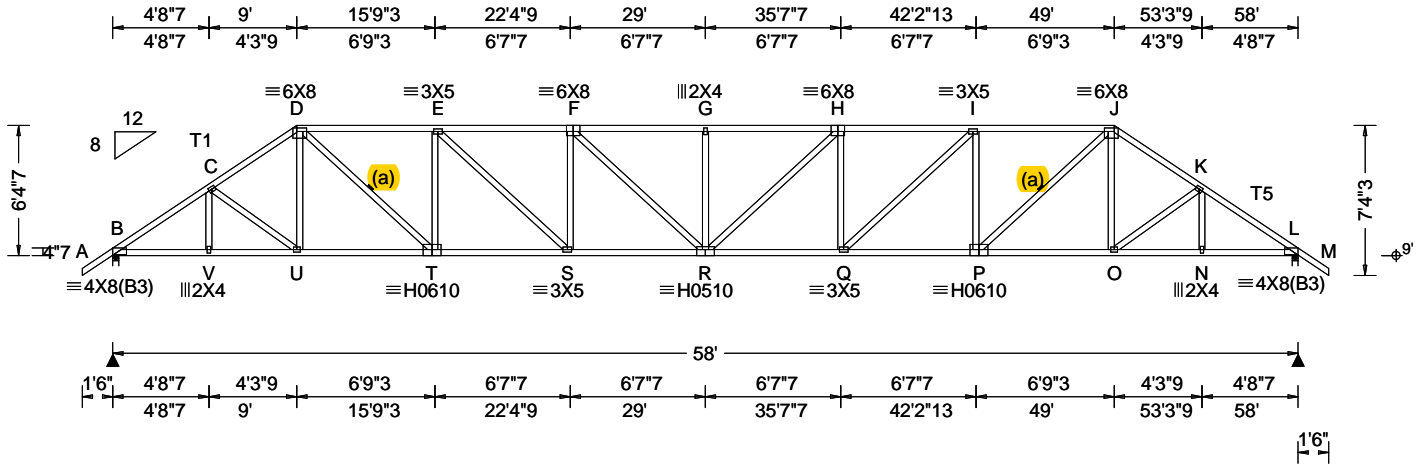

Loading Criteria (psf) TCLL: 20.00 TCDL: 10.00 BCLL: 0.00 BCDL: 10.00 Des Ld: 40.00 NCBCLL: 10.00 Soffit: 2.00 Load Duration: 1.25 Spacing: 24.0 "	Wind Criteria Wind Std: ASCE 7-22 Speed: 130 mph Enclosure: Enclosed Risk Category: II EXP: C Kzt: NA Mean Height: 15.00 ft TCDL: 5.0 psf BCDL: 5.0 psf MWFRS Parallel Dist: h to 2h C&C Dist a: 5.80 ft Loc. from endwall: not in 13.00 ft GCp: 0.18 Wind Duration: 1.60	Snow Criteria (Pg,Pf in PSF) Pg: NA Ct: NA CAT: NA Pf: NA Ce: NA Lu: NA Cs: NA Snow Duration: NA Building Code: FBC 8th Ed. 2023 Res. TPI Std: 2014 Rep Fac: Yes FT/RT:20(0)/10(0) Plate Type(s): WAVE, HS	Defl/CSI Criteria PP Deflection in loc L/defl L/# VERT(LL): 0.503 G 999 240 VERT(CL): 1.048 G 660 180 HORZ(LL): 0.133 L - - HORZ(TL): 0.276 L - - Creep Factor: 2.0 Max TC CSI: 0.619 Max BC CSI: 0.532 Max Web CSI: 0.961 VIEW Ver: 24.02.00D.0611.08	▲ Maximum Reactions (lbs) Gravity Non-Gravity Loc R+ /R- /Rh /Rw /U /RL B 2540 -/- /- /1367 /164 /190 L 2540 -/- /- /1367 /164 -/ Wind reactions based on MWFRS B Brg Wid = 3.5 Min Req = 2.1 (Truss) L Brg Wid = 3.5 Min Req = 2.1 (Truss) Bearings B & L are a rigid surface. Members not listed have forces less than 375# Maximum Top Chord Forces Per Ply (lbs) Chords Tens.Comp. Chords Tens. Comp. B - C 1199 -3882 G - H 1887 -5783 C - D 1246 -3693 H - I 1819 -5456 D - E 1586 -4542 I - J 1586 -4542 E - F 1819 -5456 J - K 1246 -3693 F - G 1887 -5783 K - L 1199 -3882
--	---	--	---	---

Lumber
Top chord: 2x4 SP M-31; T1,T5 2x4 SP #2;
Bot chord: 2x4 SP M-31;
Webs: 2x4 SP #3;

Bracing
(a) Continuous lateral restraint equally spaced on member.

Plating Notes
All plates are 3X4 except as noted.

Purlins
In lieu of structural panels use purlins to brace all flat TC @ 24" oc.

Wind
Wind loads based on MWFRS with additional C&C member design.
Wind loading based on both gable and hip roof types.

Additional Notes
WARNING: Furnish a copy of this DWG to the installation contractor. Special care must be taken during handling, shipping and installation of trusses. See "WARNING" note below.
The overall height of this truss excluding overhang is 6-4-7.



COA #0278
02/02/2026
Florida Certificate of Product Approval #FL 1999

****WARNING** READ AND FOLLOW ALL NOTES ON THIS DRAWING!**
****IMPORTANT** FURNISH THIS DRAWING TO ALL CONTRACTORS INCLUDING THE INSTALLERS**
Trusses require extreme care in fabricating, handling, shipping, installing and bracing. Refer to and follow the latest edition of BCSI (Building Component Safety Information, by TPI and SBCA) for safety practices prior to performing these functions. Installers shall provide temporary bracing per BCSI. Unless noted otherwise, top chord shall have properly attached structural sheathing and bottom chord shall have a properly attached rigid ceiling. Locations shown for permanent lateral restraint of webs shall have continuous lateral restraint (CLR), installed with diagonal bracing installed on the CLR per BCSI sections B3, B7, or B10, as applicable. Apply plates to each face of truss and position as shown above and on the Joint Details, unless noted otherwise. Refer to drawings 160A-Z for standard plate positions. Refer to job's General Notes page for additional information.
Alpine, a division of ITW Building Components Group Inc. shall not be responsible for any deviation from this drawing, any failure to build the truss in conformance with ANSI/TPI 1, or for handling, shipping, installation and bracing of trusses. A seal on this drawing or cover page listing this drawing, indicates acceptance of professional engineering responsibility solely for the design shown. The suitability and use of this drawing for any structure is the responsibility of the Building Designer per ANSI/TPI 1 Sec.2.
For more information see these web sites: Alpine: alpineitw.com; TPI: tpinst.org; SBCA: sbcacomponents.com; ICC: iccsafe.org; AWC: awc.org



2 Complete Trusses Required

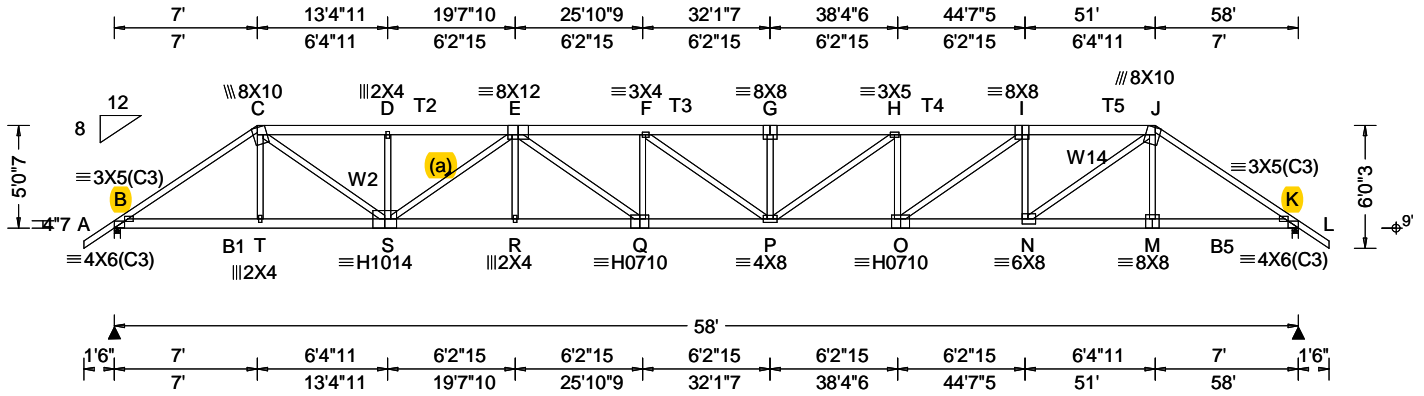

Loading Criteria (psf)	
TCLL:	20.00
TCDL:	10.00
BCLL:	0.00
BCDL:	10.00
Des Ld:	40.00
NCBCLL:	0.00
Soffit:	2.00
Load Duration:	1.25
Spacing:	24.0 "

Wind Criteria	
Wind Std:	ASCE 7-22
Speed:	130 mph
Enclosure:	Enclosed
Risk Category:	II
EXP:	C Kzt: NA
Mean Height:	15.00 ft
TCDL:	5.0 psf
BCDL:	5.0 psf
MWFRS Parallel Dist:	0 to h/2
C&C Dist a:	5.80 ft
Loc. from endwall:	not in 13.00 ft
GCp:	0.18
Wind Duration:	1.60

Snow Criteria (Pg,Pf in PSF)	
Pg: NA	Ct: NA CAT: NA
Pf: NA	Ce: NA
Lu: NA	Cs: NA
Snow Duration: NA	
Building Code:	
FBC 8th Ed. 2023 Res.	
TPI Std: 2014	
Rep Fac: Varies by Ld Case	
FT/RT:20(0)/10(0)	
Plate Type(s):	
WAVE, HS	

Defl/CSI Criteria	
PP Deflection in	loc L/defl L/#
VERT(LL):	1.346 F 514 240
VERT(CL):	1.425 F 486 180
HORZ(LL):	0.292 C - -
HORZ(TL):	0.309 C - -
Creep Factor: 2.0	
Max TC CSI: 0.733	
Max BC CSI: 0.822	
Max Web CSI: 0.808	
VIEW Ver: 24.02.00D.0611.08	

▲ Maximum Reactions (lbs)					
Gravity			Non-Gravity		
Loc	R+ / R-	/ Rh	/ Rw	/ U	/ RL
B	5854 /-	/-	/-	/1564	/-
K	5849 /-	/-	/-	/1560	/-
Wind reactions based on MWFRS					
B Brg Wid = 3.5 Min Req = 3.5 (Truss)					
K Brg Wid = 3.5 Min Req = 3.5 (Truss)					
Bearings B & K are a rigid surface.					
Members not listed have forces less than 375#					
Maximum Top Chord Forces Per Ply (lbs)					
Chords	Tens.Comp.		Chords	Tens. Comp.	
B - C	1338	-4930	G - H	2615	-9506
C - D	1881	-6852	H - I	2354	-8572
D - E	1880	-6851	I - J	1856	-6780
E - F	2611	-9491	J - K	1334	-4921
F - G	2615	-9506			

Lumber

Top chord: 2x4 SP #2; T2,T5 2x6 SP #2; T3, T4 2x6 SP 2400f-2.0E;
 Bot chord: 2x6 SP 2400f-2.0E; B1,B5 2x6 SP #2;
 Webs: 2x4 SP #3; W2,W14 2x4 SP #2;

Bracing

(a) Continuous lateral restraint equally spaced on member.

Nailnote

Nail Schedule: 0.131"x3", min. nails
 Top Chord: 1 Row @ 12.00" o.c.
 Bot Chord: 1 Row @ 12.00" o.c.
 Webs : 1 Row @ 4" o.c.
 Use equal spacing between rows and stagger nails in each row to avoid splitting.

Purlins

In lieu of structural panels use purlins to brace all flat TC @ 24" oc.

Wind

Wind loads and reactions based on MWFRS.
 Wind loading based on both gable and hip roof types.

Additional Notes

WARNING: Furnish a copy of this DWG to the installation contractor. Special care must be taken during handling, shipping and installation of trusses. See "WARNING" note below.
 The overall height of this truss excluding overhang is 5'-0-7".



COA #0278
 Florida Certificate of Product Approval #FL 1999

****WARNING** READ AND FOLLOW ALL NOTES ON THIS DRAWING!**
****IMPORTANT** FURNISH THIS DRAWING TO ALL CONTRACTORS INCLUDING THE INSTALLERS**
 Trusses require extreme care in fabricating, handling, shipping, installing and bracing. Refer to and follow the latest edition of BCSI (Building Component Safety Information, by TPI and SBCA) for safety practices prior to performing these functions. Installers shall provide temporary bracing per BCSI. Unless noted otherwise, top chord shall have properly attached structural sheathing and bottom chord shall have a properly attached rigid ceiling. Locations shown for permanent lateral restraint of webs shall have continuous lateral restraint (CLR), installed with diagonal bracing installed on the CLR per BCSI sections B3, B7, or B10, as applicable. Apply plates to each face of truss and position as shown above and on the Joint Details, unless noted otherwise. Refer to drawings 160A-Z for standard plate positions. Refer to job's General Notes page for additional information.
 Alpine, a division of ITW Building Components Group Inc. shall not be responsible for any deviation from this drawing, any failure to build the truss in conformance with ANSI/TPI 1, or for handling, shipping, installation and bracing of trusses. A seal on this drawing or cover page listing this drawing, indicates acceptance of professional engineering responsibility solely for the design shown. The suitability and use of this drawing for any structure is the responsibility of the Building Designer per ANSI/TPI 1 Sec.2.
 For more information see these web sites: Alpine: alpineitw.com; TPI: tpinst.org; SBCA: sbccomponents.com; ICC: iccsafe.org; AWC: awc.org



Special Loads

----- (Lumber Dur.Fac.=1.25 / Plate Dur.Fac.=1.25)
 TC: From 64 plf at -1.50 to 64 plf at 7.00
 TC: From 32 plf at 7.00 to 32 plf at 51.00
 TC: From 64 plf at 51.00 to 64 plf at 59.50
 BC: From 5 plf at -1.50 to 5 plf at 0.00
 BC: From 20 plf at 0.00 to 20 plf at 7.01
 BC: From 10 plf at 7.01 to 10 plf at 50.85
 BC: From 20 plf at 50.85 to 20 plf at 58.00
 BC: From 5 plf at 58.00 to 5 plf at 59.50
 TC: 276 lb Conc. Load at 7.01,50.99
 TC: 193 lb Conc. Load at 9.06,46.94,48.94
 TC: 200 lb Conc. Load at 11.06,13.06,15.06,17.06
 19.06,21.06,23.06,25.06,27.06,29.00,30.94,32.94
 34.94,36.94,38.94,40.94,42.94,44.94
 BC: 477 lb Conc. Load at 7.01,50.99
 BC: 131 lb Conc. Load at 9.06,46.94,48.94
 BC: 133 lb Conc. Load at 11.06,13.06,15.06,17.06
 19.06,21.06,23.06,25.06,27.06,29.00,30.94,32.94
 34.94,36.94,38.94,40.94,42.94,44.94



COA #0278

02/02/2026
 Florida Certificate of Product Approval #FL 1999

****WARNING** READ AND FOLLOW ALL NOTES ON THIS DRAWING!**
****IMPORTANT** FURNISH THIS DRAWING TO ALL CONTRACTORS INCLUDING THE INSTALLERS**
 Trusses require extreme care in fabricating, handling, shipping, installing and bracing. Refer to and follow the latest edition of BCSI (Building Component Safety Information, by TPI and SBCA) for safety practices prior to performing these functions. Installers shall provide temporary bracing per BCSI. Unless noted otherwise, top chord shall have properly attached structural sheathing and bottom chord shall have a properly attached rigid ceiling. Locations shown for permanent lateral restraint of webs shall have continuous lateral restraint (CLR), installed with diagonal bracing installed on the CLR per BCSI sections B3, B7, or B10, as applicable. Apply plates to each face of truss and position as shown above and on the Joint Details, unless noted otherwise. Refer to drawings 160A-Z for standard plate positions. Refer to job's General Notes page for additional information.
 Alpine, a division of ITW Building Components Group Inc. shall not be responsible for any deviation from this drawing, any failure to build the truss in conformance with ANSI/TPI 1, or for handling, shipping, installation and bracing of trusses. A seal on this drawing or cover page listing this drawing, indicates acceptance of professional engineering responsibility solely for the design shown. The suitability and use of this drawing for any structure is the responsibility of the Building Designer per ANSI/TPI 1 Sec.2.
 For more information see these web sites: Alpine: alpineitw.com; TPI: tpinst.org; SBCA: sbcacomponents.com; ICC: iccsafe.org; AWC: awc.org



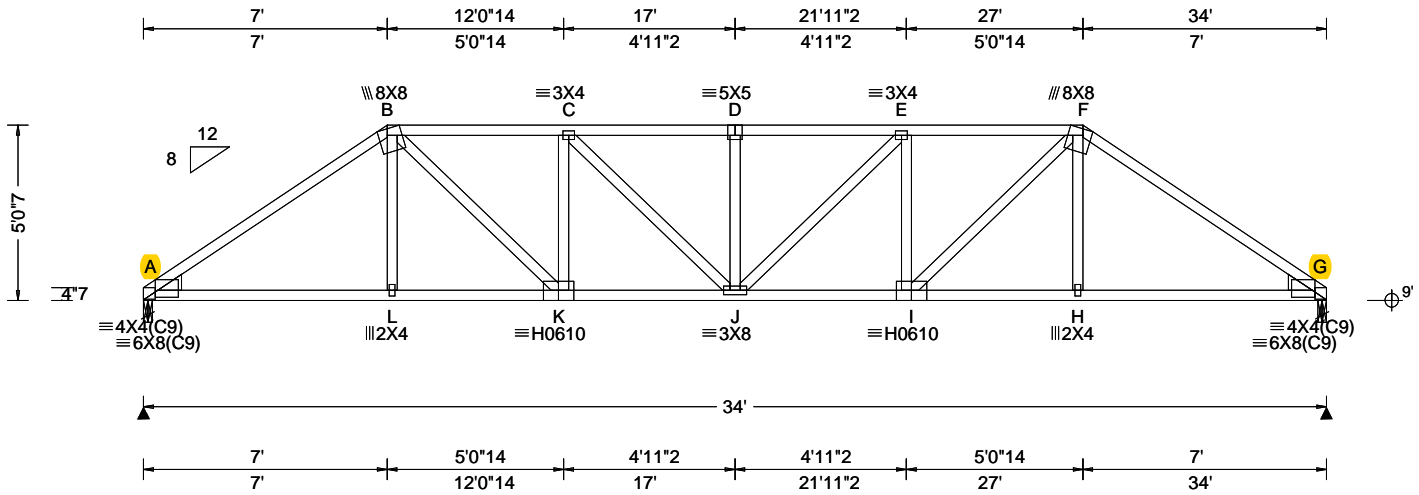

Loading Criteria (psf) TCLL: 20.00 TCDL: 10.00 BCLL: 0.00 BCDL: 10.00 Des Ld: 40.00 NCBCLL: 10.00 Soffit: 2.00 Load Duration: 1.25 Spacing: 24.0 "	Wind Criteria Wind Std: ASCE 7-22 Speed: 130 mph Enclosure: Enclosed Risk Category: II EXP: C Kzt: NA Mean Height: 15.00 ft TCDL: 5.0 psf BCDL: 5.0 psf MWFRS Parallel Dist: 0 to h/2 C&C Dist a: 3.40 ft Loc. from endwall: not in 4.50 ft GCp: 0.18 Wind Duration: 1.60	Snow Criteria (Pg,Pf in PSF) Pg: NA Ct: NA CAT: NA Pf: NA Ce: NA Lu: NA Cs: NA Snow Duration: NA Building Code: FBC 8th Ed. 2023 Res. TPI Std: 2014 Rep Fac: Varies by Ld Case FT/RT:20(0)/10(0) Plate Type(s): WAVE, HS	Defl/CSI Criteria PP Deflection in loc L/defl L/# VERT(LL): 0.281 D 999 240 VERT(CL): 0.571 D 709 180 HORZ(LL): 0.095 G - - HORZ(TL): 0.194 G - - Creep Factor: 2.0 Max TC CSI: 0.653 Max BC CSI: 0.696 Max Web CSI: 0.838 VIEW Ver: 24.02.00D.0611.08	▲ Maximum Reactions (lbs) Gravity Loc R+ / R- / Rh / Rw / U / RL Non-Gravity A 3216 - / - / - / 816 - / - G 3216 - / - / - / 816 - / - Wind reactions based on MWFRS A Brg Wid = 3.0 Min Req = 2.7 (Truss) G Brg Wid = 3.0 Min Req = 2.7 (Truss) Bearings A & G are a rigid surface. Members not listed have forces less than 375# Maximum Top Chord Forces Per Ply (lbs) Chords Tens.Comp. Chords Tens. Comp. A - B 1396 -5274 D - E 1717 -6446 B - C 1566 -5883 E - F 1566 -5883 C - D 1717 -6446 F - G 1396 -5274
--	---	--	---	---

Lumber
Top chord: 2x4 SP M-31;
Bot chord: 2x4 SP M-31;
Webs: 2x4 SP #3;
Lt Wedge: 2x6 SP #2; Rt Wedge: 2x6 SP #2;

Special Loads
-----(Lumber Dur.Fac.=1.25 / Plate Dur.Fac.=1.25)
TC: From 64 plf at 0.00 to 64 plf at 7.00
TC: From 32 plf at 7.00 to 32 plf at 27.00
TC: From 64 plf at 27.00 to 64 plf at 34.00
BC: From 20 plf at 0.00 to 20 plf at 7.01
BC: From 10 plf at 7.01 to 10 plf at 26.99
BC: From 20 plf at 26.99 to 20 plf at 34.00
TC: 276 lb Conc. Load at 7.01,26.99
TC: 193 lb Conc. Load at 9.06,11.06,13.06,15.06
17.00,18.94,20.94,22.94,24.94
BC: 477 lb Conc. Load at 7.01,26.99
BC: 131 lb Conc. Load at 9.06,11.06,13.06,15.06
17.00,18.94,20.94,22.94,24.94

Purlins
In lieu of structural panels use purlins to brace all flat TC @ 24" oc.

Wind
Wind loads and reactions based on MWFRS.
Wind loading based on both gable and hip roof types.

Additional Notes
The overall height of this truss excluding overhang is 5-0-7.

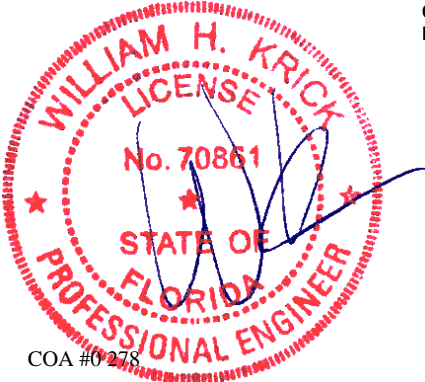

COA #0 278
02/02/2026
Florida Certificate of Product Approval #FL 1999

****WARNING** READ AND FOLLOW ALL NOTES ON THIS DRAWING!**
****IMPORTANT** FURNISH THIS DRAWING TO ALL CONTRACTORS INCLUDING THE INSTALLERS**
Trusses require extreme care in fabricating, handling, shipping, installing and bracing. Refer to and follow the latest edition of BCSI (Building Component Safety Information, by TPI and SBCA) for safety practices prior to performing these functions. Installers shall provide temporary bracing per BCSI. Unless noted otherwise, top chord shall have properly attached structural sheathing and bottom chord shall have a properly attached rigid ceiling. Locations shown for permanent lateral restraint of webs shall have continuous lateral restraint (CLR), installed with diagonal bracing installed on the CLR per BCSI sections B3, B7, or B10, as applicable. Apply plates to each face of truss and position as shown above and on the Joint Details, unless noted otherwise. Refer to drawings 160A-Z for standard plate positions. Refer to job's General Notes page for additional information.
Alpine, a division of ITW Building Components Group Inc. shall not be responsible for any deviation from this drawing, any failure to build the truss in conformance with ANSI/TPI 1, or for handling, shipping, installation and bracing of trusses. A seal on this drawing or cover page listing this drawing, indicates acceptance of professional engineering responsibility solely for the design shown. The suitability and use of this drawing for any structure is the responsibility of the Building Designer per ANSI/TPI 1 Sec.2.
For more information see these web sites: Alpine: alpineitw.com; TPI: tpinst.org; SBCA: sbccomponents.com; ICC: iccsafe.org; AWC: awc.org



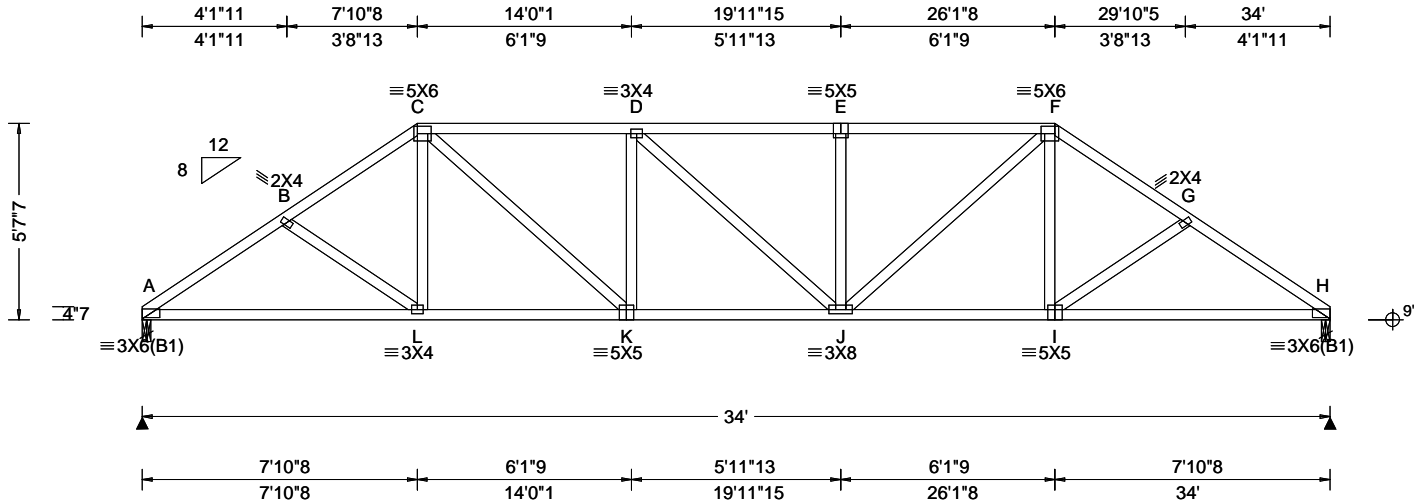

Loading Criteria (psf) TCLL: 20.00 TCDL: 10.00 BCLL: 0.00 BCDL: 10.00 Des Ld: 40.00 NCBCLL: 10.00 Soffit: 2.00 Load Duration: 1.25 Spacing: 24.0 "	Wind Criteria Wind Std: ASCE 7-22 Speed: 130 mph Enclosure: Enclosed Risk Category: II EXP: C Kzt: NA Mean Height: 15.00 ft TCDL: 5.0 psf BCDL: 5.0 psf MWFRS Parallel Dist: h/2 to h C&C Dist a: 3.40 ft Loc. from endwall: not in 9.00 ft GCpi: 0.18 Wind Duration: 1.60	Snow Criteria (Pg,Pf in PSF) Pg: NA Ct: NA CAT: NA Pf: NA Ce: NA Lu: NA Cs: NA Snow Duration: NA Building Code: FBC 8th Ed. 2023 Res. TPI Std: 2014 Rep Fac: Yes FT/RT:20(0)/10(0) Plate Type(s): WAVE	Defl/CSI Criteria PP Deflection in loc L/defl L/# VERT(LL): 0.119 E 999 240 VERT(CL): 0.250 E 999 180 HORZ(LL): 0.047 H - - HORZ(TL): 0.098 H - - Creep Factor: 2.0 Max TC CSI: 0.526 Max BC CSI: 0.638 Max Web CSI: 0.494 VIEW Ver: 24.02.00D.0611.08	▲ Maximum Reactions (lbs) Gravity Non-Gravity Loc R+ / R- / Rh / Rw / U / RL A 1429 - / - /811 /245 /149 H 1429 - / - /811 /245 - Wind reactions based on MWFRS A Brg Wid = 3.0 Min Req = 1.7 (Truss) H Brg Wid = 3.0 Min Req = 1.7 (Truss) Bearings A & H are a rigid surface. Members not listed have forces less than 375# Maximum Top Chord Forces Per Ply (lbs) Chords Tens.Comp. Chords Tens. Comp. A - B 888 -2213 E - F 1083 -2219 B - C 874 -2017 F - G 874 -2017 C - D 1074 -2204 G - H 889 -2213 D - E 1083 -2219 Maximum Bot Chord Forces Per Ply (lbs) Chords Tens.Comp. Chords Tens. Comp. A - L 1778 -665 J - I 1631 -576 L - K 1632 -573 I - H 1778 -663 K - J 2225 -894 Maximum Web Forces Per Ply (lbs) Webs Tens.Comp. Webs Tens. Comp. C - K 765 -405 E - J 325 -383 K - D 325 -391 J - F 777 -412
--	--	--	---	--

Lumber

Top chord: 2x4 SP #2;
Bot chord: 2x4 SP #2;
Webs: 2x4 SP #3;

Purlins

In lieu of structural panels use purlins to brace all flat TC @ 24" oc.

Wind

Wind loads based on MWFRS with additional C&C member design.
Wind loading based on both gable and hip roof types.

Additional Notes

The overall height of this truss excluding overhang is 5-7-7.



COA #0278

02/02/2026
Florida Certificate of Product Approval #FL 1999

****WARNING** READ AND FOLLOW ALL NOTES ON THIS DRAWING!**
****IMPORTANT** FURNISH THIS DRAWING TO ALL CONTRACTORS INCLUDING THE INSTALLERS**
Trusses require extreme care in fabricating, handling, shipping, installing and bracing. Refer to and follow the latest edition of BCSI (Building Component Safety Information, by TPI and SBCA) for safety practices prior to performing these functions. Installers shall provide temporary bracing per BCSI. Unless noted otherwise, top chord shall have properly attached structural sheathing and bottom chord shall have a properly attached rigid ceiling. Locations shown for permanent lateral restraint of webs shall have continuous lateral restraint (CLR), installed with diagonal bracing installed on the CLR per BCSI sections B3, B7, or B10, as applicable. Apply plates to each face of truss and position as shown above and on the Joint Details, unless noted otherwise. Refer to drawings 160A-Z for standard plate positions. Refer to job's General Notes page for additional information.
Alpine, a division of ITW Building Components Group Inc. shall not be responsible for any deviation from this drawing, any failure to build the truss in conformance with ANSI/TPI 1, or for handling, shipping, installation and bracing of trusses. A seal on this drawing or cover page listing this drawing, indicates acceptance of professional engineering responsibility solely for the design shown. The suitability and use of this drawing for any structure is the responsibility of the Building Designer per ANSI/TPI 1 Sec.2.
For more information see these web sites: Alpine: alpineitw.com; TPI: tpinst.org; SBCA: sbccomponents.com; ICC: iccsafe.org; AWC: awc.org



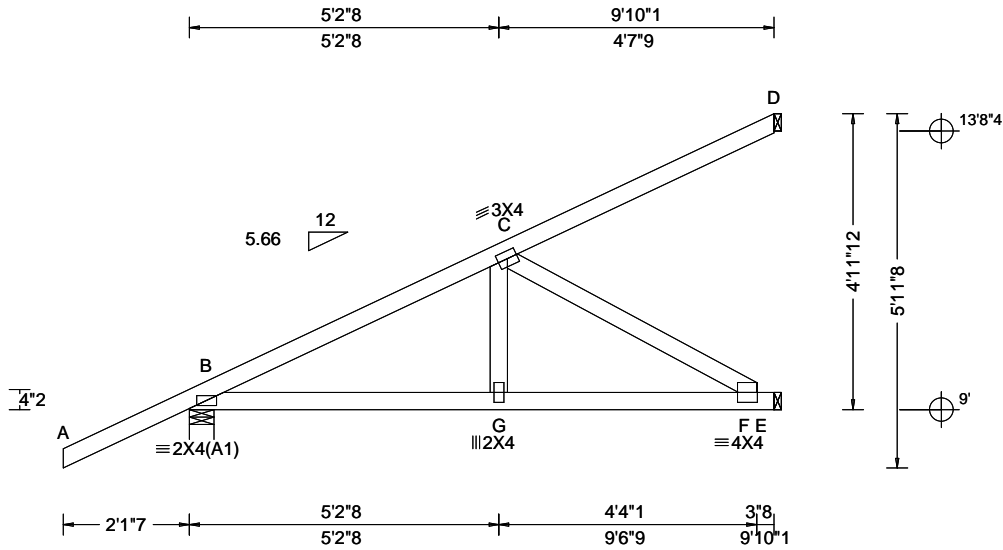

Loading Criteria (psf) TCLL: 20.00 TCDL: 10.00 BCLL: 0.00 BCDL: 10.00 Des Ld: 40.00 NCBCLL: 10.00 Soffit: 2.00 Load Duration: 1.25 Spacing: 24.0 "	Wind Criteria Wind Std: ASCE 7-22 Speed: 130 mph Enclosure: Enclosed Risk Category: II EXP: C Kzt: NA Mean Height: 15.00 ft TCDL: 5.0 psf BCDL: 5.0 psf MWFRS Parallel Dist: 0 to h/2 C&C Dist a: 3.00 ft Loc. from endwall: not in 4.50 ft GCp: 0.18 Wind Duration: 1.60	Snow Criteria (Pg,Pf in PSF) Pg: NA Ct: NA CAT: NA Pf: NA Ce: NA Lu: NA Cs: NA Snow Duration: NA Building Code: FBC 8th Ed. 2023 Res. TPI Std: 2014 Rep Fac: Varies by Ld Case FT/RT:20(0)/10(0) Plate Type(s): WAVE	Defl/CSI Criteria PP Deflection in loc L/defl L/# VERT(LL): 0.022 G 999 240 VERT(CL): 0.035 G 999 180 HORZ(LL): -0.005 B - - HORZ(TL): 0.009 C - - Creep Factor: 2.0 Max TC CSI: 0.604 Max BC CSI: 0.647 Max Web CSI: 0.307 VIEW Ver: 24.02.00D.0611.08	▲ Maximum Reactions (lbs) Gravity Non-Gravity Loc R+ /R- /Rh /Rw /U /RL B 373 -/- /- /108 -/ E 347 -/- /- /73 -/ D 83 -/- /- /42 -/ Wind reactions based on MWFRS B Brg Wid = 4.9 Min Req = 1.5 (Truss) E Brg Wid = 1.5 Min Req = - D Brg Wid = 1.5 Min Req = - Bearing B is a rigid surface. Members not listed have forces less than 375# Maximum Top Chord Forces Per Ply (lbs) Chords Tens.Comp. B - C 167 -583 Maximum Bot Chord Forces Per Ply (lbs) Chords Tens.Comp. Chords Tens. Comp. B - G 528 -144 G - F 520 -146 Maximum Web Forces Per Ply (lbs) Webs Tens.Comp. C - F 170 -604
--	---	--	--	---

Lumber

Top chord: 2x4 SP #2;
Bot chord: 2x4 SP #2;
Webs: 2x4 SP #3;

Special Loads

----(Lumber Dur.Fac.=1.25 / Plate Dur.Fac.=1.25)
TC: From 0 plf at -2.12 to 62 plf at 0.00
TC: From 2 plf at 0.00 to 2 plf at 9.84
BC: From 0 plf at -2.12 to 4 plf at 0.00
BC: From 2 plf at 0.00 to 2 plf at 9.84
TC: -19 lb Conc. Load at 1.48
TC: 128 lb Conc. Load at 4.31
TC: 263 lb Conc. Load at 7.13
BC: 10 lb Conc. Load at 1.48
BC: 100 lb Conc. Load at 4.31
BC: 182 lb Conc. Load at 7.13

Wind

Wind loads and reactions based on MWFRS.
Wind loading based on both gable and hip roof types.

Additional Notes

The overall height of this truss excluding overhang is 4-11-12.

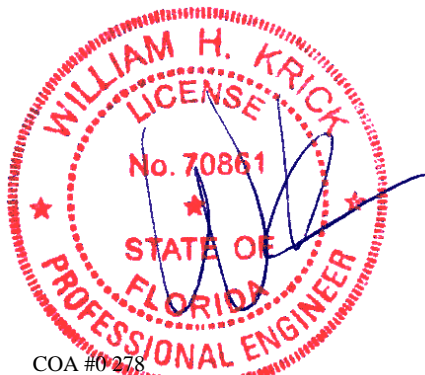

COA #0278

Florida Certificate of Product Approval #FL 1999

****WARNING** READ AND FOLLOW ALL NOTES ON THIS DRAWING!**
****IMPORTANT** FURNISH THIS DRAWING TO ALL CONTRACTORS INCLUDING THE INSTALLERS**
Trusses require extreme care in fabricating, handling, shipping, installing and bracing. Refer to and follow the latest edition of BCSI (Building Component Safety Information, by TPI and SBCA) for safety practices prior to performing these functions. Installers shall provide temporary bracing per BCSI. Unless noted otherwise, top chord shall have properly attached structural sheathing and bottom chord shall have a properly attached rigid ceiling. Locations shown for permanent lateral restraint of webs shall have continuous lateral restraint (CLR), installed with diagonal bracing installed on the CLR per BCSI sections B3, B7, or B10, as applicable. Apply plates to each face of truss and position as shown above and on the Joint Details, unless noted otherwise. Refer to drawings 160A-Z for standard plate positions. Refer to job's General Notes page for additional information.
Alpine, a division of ITW Building Components Group Inc. shall not be responsible for any deviation from this drawing, any failure to build the truss in conformance with ANSI/TPI 1, or for handling, shipping, installation and bracing of trusses. A seal on this drawing or cover page listing this drawing, indicates acceptance of professional engineering responsibility solely for the design shown. The suitability and use of this drawing for any structure is the responsibility of the Building Designer per ANSI/TPI 1 Sec.2.
For more information see these web sites: Alpine: alpineitw.com; TPI: tpinst.org; SBCA: sbccomponents.com; ICC: iccsafe.org; AWC: awc.org



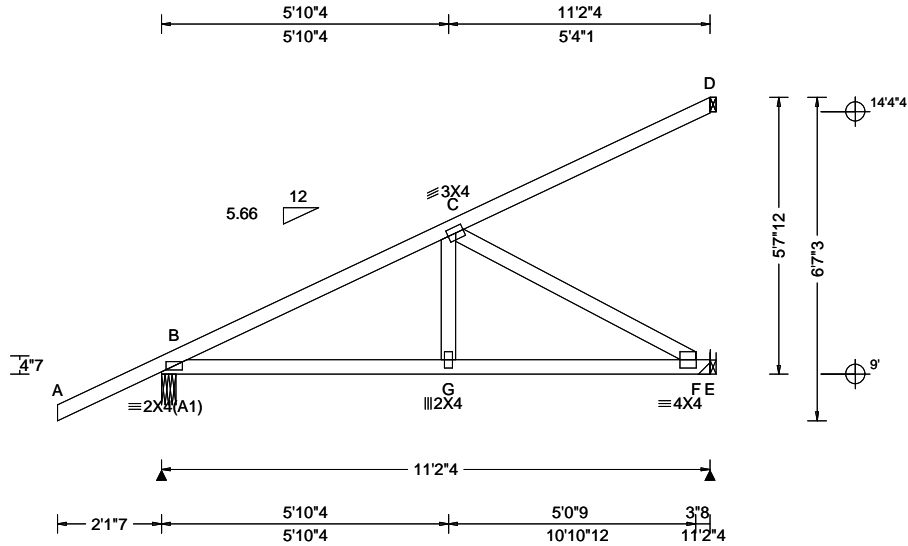

Loading Criteria (psf) TCLL: 20.00 TCDL: 10.00 BCLL: 0.00 BCDL: 10.00 Des Ld: 40.00 NCBCLL: 0.00 Soffit: 2.00 Load Duration: 1.25 Spacing: 24.0 "	Wind Criteria Wind Std: ASCE 7-22 Speed: 130 mph Enclosure: Enclosed Risk Category: II EXP: C Kzt: NA Mean Height: 15.00 ft TCDL: 5.0 psf BCDL: 5.0 psf MWFRS Parallel Dist: 0 to h/2 C&C Dist a: 3.00 ft Loc. from endwall: NA GCp: 0.18 Wind Duration: 1.60	Snow Criteria (Pg,Pf in PSF) Pg: NA Ct: NA CAT: NA Pf: NA Ce: NA Lu: NA Cs: NA Snow Duration: NA Building Code: FBC 8th Ed. 2023 Res. TPI Std: 2014 Rep Fac: No FT/RT:20(0)/10(0) Plate Type(s): WAVE	Defl/CSI Criteria PP Deflection in loc L/defl L/# VERT(LL): 0.022 G 999 240 VERT(CL): 0.045 G 999 180 HORZ(LL): 0.006 C - - HORZ(TL): 0.012 C - - Creep Factor: 2.0 Max TC CSI: 0.314 Max BC CSI: 0.350 Max Web CSI: 0.544 VIEW Ver: 24.02.00D.0611.08	▲ Maximum Reactions (lbs) Gravity Loc R+ / R- / Rh / Rw / U / RL Non-Gravity B 532 - / - / - / 97 - E 636 - / - / - / 63 - D 188 - / - / - / 68 - Wind reactions based on MWFRS B Brg Wid = 3.5 Min Req = 1.5 (Truss) E Brg Wid = - Min Req = - D Brg Wid = 1.5 Min Req = - Bearing B is a rigid surface. Members not listed have forces less than 375# Maximum Top Chord Forces Per Ply (lbs) Chords Tens.Comp. B - C 132 -823 Maximum Bot Chord Forces Per Ply (lbs) Chords Tens.Comp. Chords Tens. Comp. B - G 715 -111 G - F 708 -113 Maximum Web Forces Per Ply (lbs) Webs Tens.Comp. C - F 130 -818
---	---	---	---	--

Lumber

Top chord: 2x4 SP M-31;
Bot chord: 2x4 SP M-31;
Webs: 2x4 SP #3;

Loading

Hipjack supports 7-10-15 setback jacks. Jacks up to 7' have no webs. Longer jacks supported to BC.

Wind

Wind loads and reactions based on MWFRS.
Wind loading based on both gable and hip roof types.

Additional Notes

The overall height of this truss excluding overhang is 5-7-12.



COA #0278

Florida Certificate of Product Approval #FL 1999

****WARNING** READ AND FOLLOW ALL NOTES ON THIS DRAWING!**
****IMPORTANT** FURNISH THIS DRAWING TO ALL CONTRACTORS INCLUDING THE INSTALLERS**
Trusses require extreme care in fabricating, handling, shipping, installing and bracing. Refer to and follow the latest edition of BCSI (Building Component Safety Information, by TPI and SBCA) for safety practices prior to performing these functions. Installers shall provide temporary bracing per BCSI. Unless noted otherwise, top chord shall have properly attached structural sheathing and bottom chord shall have a properly attached rigid ceiling. Locations shown for permanent lateral restraint of webs shall have continuous lateral restraint (CLR), installed with diagonal bracing installed on the CLR per BCSI sections B3, B7, or B10, as applicable. Apply plates to each face of truss and position as shown above and on the Joint Details, unless noted otherwise. Refer to drawings 160A-Z for standard plate positions. Refer to job's General Notes page for additional information.
Alpine, a division of ITW Building Components Group Inc. shall not be responsible for any deviation from this drawing, any failure to build the truss in conformance with ANSI/TPI 1, or for handling, shipping, installation and bracing of trusses. A seal on this drawing or cover page listing this drawing, indicates acceptance of professional engineering responsibility solely for the design shown. The suitability and use of this drawing for any structure is the responsibility of the Building Designer per ANSI/TPI 1 Sec.2.
For more information see these web sites: Alpine: alpineitw.com; TPI: tpinst.org; SBCA: sbccomponents.com; ICC: iccsafe.org; AWC: awc.org



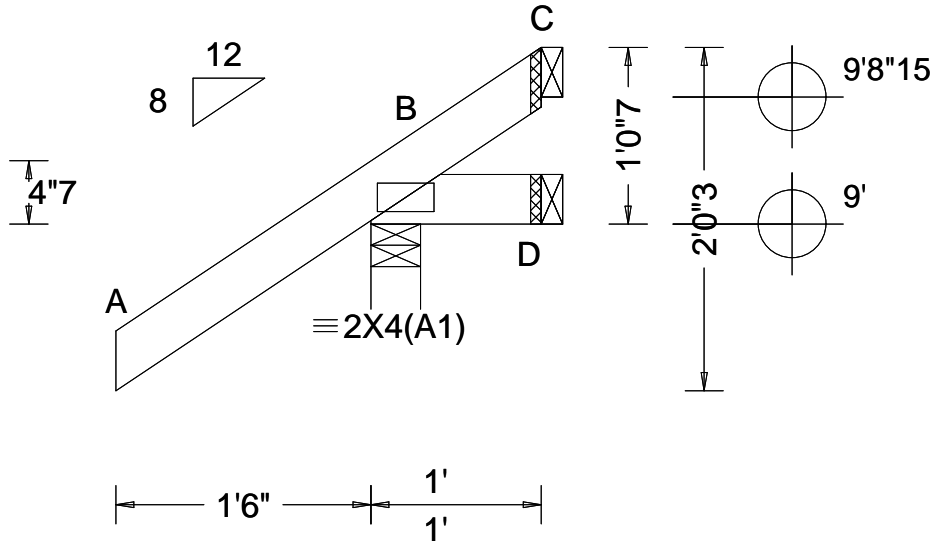

Loading Criteria (psf) TCLL: 20.00 TCDL: 10.00 BCLL: 0.00 BCDL: 10.00 Des Ld: 40.00 NCBCLL: 10.00 Soffit: 2.00 Load Duration: 1.25 Spacing: 24.0 "	Wind Criteria Wind Std: ASCE 7-22 Speed: 130 mph Enclosure: Enclosed Risk Category: II EXP: C Kzt: NA Mean Height: 15.00 ft TCDL: 5.0 psf BCDL: 5.0 psf MWFRS Parallel Dist: 0 to h/2 C&C Dist a: 3.00 ft Loc. from endwall: Any GCp: 0.18 Wind Duration: 1.60	Snow Criteria (Pg,Pf in PSF) Pg: NA Ct: NA CAT: NA Pf: NA Ce: NA Lu: NA Cs: NA Snow Duration: NA Building Code: FBC 8th Ed. 2023 Res. TPI Std: 2014 Rep Fac: Yes FT/RT:20(0)/10(0) Plate Type(s): WAVE	Defl/CSI Criteria PP Deflection in loc L/defl L/# VERT(LL): NA VERT(CL): NA HORZ(LL): -0.000 B - - HORZ(TL): 0.001 B - - Creep Factor: 2.0 Max TC CSI: 0.279 Max BC CSI: 0.044 Max Web CSI: 0.000 VIEW Ver: 24.02.00D.0611.08	▲ Maximum Reactions (lbs) <table border="1"> <thead> <tr> <th rowspan="2">Loc</th> <th colspan="3">Gravity</th> <th colspan="3">Non-Gravity</th> </tr> <tr> <th>R+</th> <th>/R-</th> <th>/Rh</th> <th>/Rw</th> <th>/U</th> <th>/RL</th> </tr> </thead> <tbody> <tr> <td>B</td> <td>261</td> <td>/-</td> <td>/-</td> <td>/80</td> <td>/63</td> <td>/50</td> </tr> <tr> <td>D</td> <td>5</td> <td>/-16</td> <td>/-</td> <td>/15</td> <td>/-</td> <td>/-</td> </tr> <tr> <td>C</td> <td>-</td> <td>/-57</td> <td>/-</td> <td>/38</td> <td>/10</td> <td>/-</td> </tr> </tbody> </table>	Loc	Gravity			Non-Gravity			R+	/R-	/Rh	/Rw	/U	/RL	B	261	/-	/-	/80	/63	/50	D	5	/-16	/-	/15	/-	/-	C	-	/-57	/-	/38	/10	/-
				Loc		Gravity			Non-Gravity																													
R+	/R-	/Rh	/Rw		/U	/RL																																
B	261	/-	/-	/80	/63	/50																																
D	5	/-16	/-	/15	/-	/-																																
C	-	/-57	/-	/38	/10	/-																																
Wind reactions based on MWFRS B Brg Wid = 3.5 Min Req = 1.5 (Truss) D Brg Wid = 1.5 Min Req = - C Brg Wid = 1.5 Min Req = - Bearing B is a rigid surface. Members not listed have forces less than 375#																																						

Lumber

Top chord: 2x4 SP #2;
 Bot chord: 2x4 SP #2;

Wind

Wind loads based on MWFRS with additional C&C member design.
 Wind loading based on both gable and hip roof types.

Additional Notes

The overall height of this truss excluding overhang is 1-0-7.

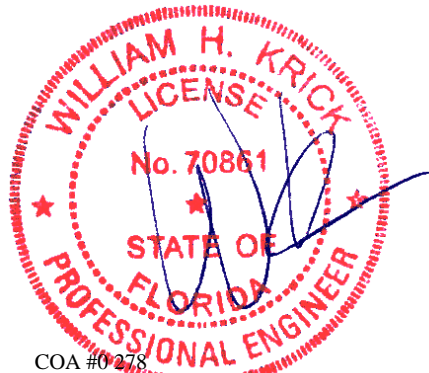

COA #0218

Florida Certificate of Product Approval #FL 1999

****WARNING** READ AND FOLLOW ALL NOTES ON THIS DRAWING!**
****IMPORTANT** FURNISH THIS DRAWING TO ALL CONTRACTORS INCLUDING THE INSTALLERS**
 Trusses require extreme care in fabricating, handling, shipping, installing and bracing. Refer to and follow the latest edition of BCSI (Building Component Safety Information, by TPI and SBCA) for safety practices prior to performing these functions. Installers shall provide temporary bracing per BCSI. Unless noted otherwise, top chord shall have properly attached structural sheathing and bottom chord shall have a properly attached rigid ceiling. Locations shown for permanent lateral restraint of webs shall have continuous lateral restraint (CLR), installed with diagonal bracing installed on the CLR per BCSI sections B3, B7, or B10, as applicable. Apply plates to each face of truss and position as shown above and on the Joint Details, unless noted otherwise. Refer to drawings 160A-Z for standard plate positions. Refer to job's General Notes page for additional information.
 Alpine, a division of ITW Building Components Group Inc. shall not be responsible for any deviation from this drawing, any failure to build the truss in conformance with ANSI/TPI 1, or for handling, shipping, installation and bracing of trusses. A seal on this drawing or cover page listing this drawing, indicates acceptance of professional engineering responsibility solely for the design shown. The suitability and use of this drawing for any structure is the responsibility of the Building Designer per ANSI/TPI 1 Sec.2.
 For more information see these web sites: Alpine: alpineitw.com; TPI: tpinst.org; SBCA: sbccomponents.com; ICC: iccsafe.org; AWC: awc.org



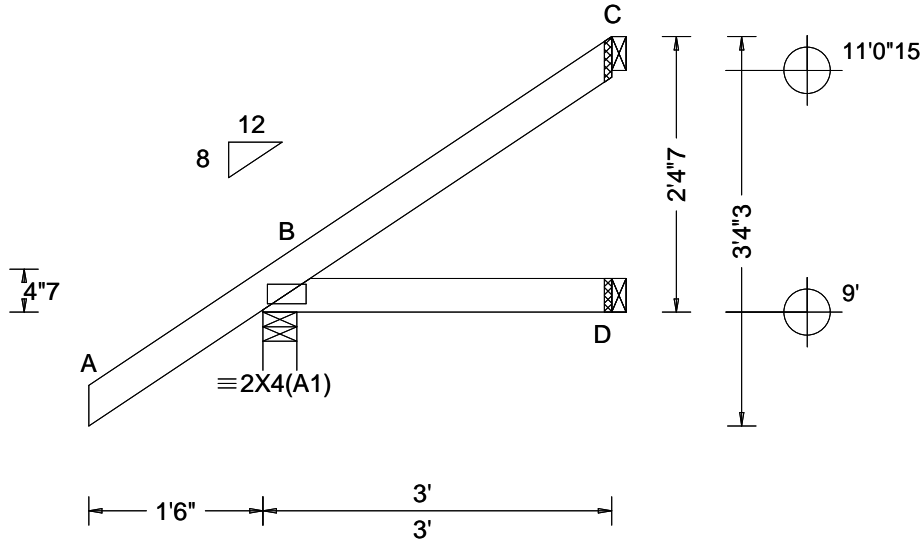

Loading Criteria (psf) TCCL: 20.00 TCDL: 10.00 BCLL: 0.00 BCDL: 10.00 Des Ld: 40.00 NCBCLL: 10.00 Soffit: 2.00 Load Duration: 1.25 Spacing: 24.0 "	Wind Criteria Wind Std: ASCE 7-22 Speed: 130 mph Enclosure: Enclosed Risk Category: II EXP: C Kzt: NA Mean Height: 15.00 ft TCDL: 5.0 psf BCDL: 5.0 psf MWFRS Parallel Dist: 0 to h/2 C&C Dist a: 3.00 ft Loc. from endwall: not in 4.50 ft GCp: 0.18 Wind Duration: 1.60	Snow Criteria (Pg,Pf in PSF) Pg: NA Ct: NA CAT: NA Pf: NA Ce: NA Lu: NA Cs: NA Snow Duration: NA Building Code: FBC 8th Ed. 2023 Res. TPI Std: 2014 Rep Fac: Yes FT/RT:20(0)/10(0) Plate Type(s): WAVE	Defl/CSI Criteria PP Deflection in loc L/defl L/# VERT(LL): NA VERT(CL): NA HORZ(LL): 0.000 B - - HORZ(TL): 0.001 B - - Creep Factor: 2.0 Max TC CSI: 0.249 Max BC CSI: 0.067 Max Web CSI: 0.000 VIEW Ver: 24.02.00D.0611.08	▲ Maximum Reactions (lbs) <table border="1"> <thead> <tr> <th rowspan="2">Loc</th> <th colspan="3">Gravity</th> <th colspan="3">Non-Gravity</th> </tr> <tr> <th>R+</th> <th>/R-</th> <th>/Rh</th> <th>/Rw</th> <th>/U</th> <th>/RL</th> </tr> </thead> <tbody> <tr> <td>B</td> <td>268</td> <td>/-</td> <td>/-</td> <td>/106</td> <td>/29</td> <td>/98</td> </tr> <tr> <td>D</td> <td>50</td> <td>/-</td> <td>/-</td> <td>/33</td> <td>/-</td> <td>/-</td> </tr> <tr> <td>C</td> <td>64</td> <td>/-</td> <td>/-</td> <td>/61</td> <td>/43</td> <td>/-</td> </tr> </tbody> </table>	Loc	Gravity			Non-Gravity			R+	/R-	/Rh	/Rw	/U	/RL	B	268	/-	/-	/106	/29	/98	D	50	/-	/-	/33	/-	/-	C	64	/-	/-	/61	/43	/-
				Loc		Gravity			Non-Gravity																													
R+	/R-	/Rh	/Rw		/U	/RL																																
B	268	/-	/-	/106	/29	/98																																
D	50	/-	/-	/33	/-	/-																																
C	64	/-	/-	/61	/43	/-																																
Wind reactions based on MWFRS B Brg Wid = 3.5 Min Req = 1.5 (Truss) D Brg Wid = 1.5 Min Req = - C Brg Wid = 1.5 Min Req = - Bearing B is a rigid surface. Members not listed have forces less than 375#																																						

Lumber

Top chord: 2x4 SP #2;
 Bot chord: 2x4 SP #2;

Wind

Wind loads based on MWFRS with additional C&C member design.
 Wind loading based on both gable and hip roof types.

Additional Notes

The overall height of this truss excluding overhang is 2-4-7.

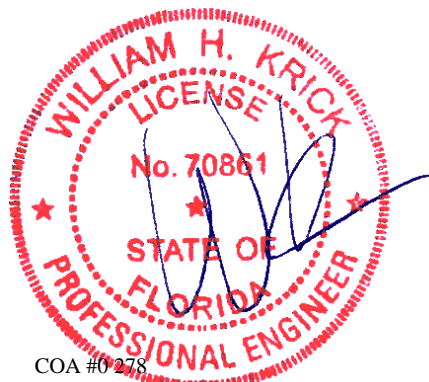

COA #0278

02/02/2026
 Florida Certificate of Product Approval #FL 1999

****WARNING** READ AND FOLLOW ALL NOTES ON THIS DRAWING!**
****IMPORTANT** FURNISH THIS DRAWING TO ALL CONTRACTORS INCLUDING THE INSTALLERS**
 Trusses require extreme care in fabricating, handling, shipping, installing and bracing. Refer to and follow the latest edition of BCSI (Building Component Safety Information, by TPI and SBCA) for safety practices prior to performing these functions. Installers shall provide temporary bracing per BCSI. Unless noted otherwise, top chord shall have properly attached structural sheathing and bottom chord shall have a properly attached rigid ceiling. Locations shown for permanent lateral restraint of webs shall have continuous lateral restraint (CLR), installed with diagonal bracing installed on the CLR per BCSI sections B3, B7, or B10, as applicable. Apply plates to each face of truss and position as shown above and on the Joint Details, unless noted otherwise. Refer to drawings 160A-Z for standard plate positions. Refer to job's General Notes page for additional information.
 Alpine, a division of ITW Building Components Group Inc. shall not be responsible for any deviation from this drawing, any failure to build the truss in conformance with ANSI/TPI 1, or for handling, shipping, installation and bracing of trusses. A seal on this drawing or cover page listing this drawing, indicates acceptance of professional engineering responsibility solely for the design shown. The suitability and use of this drawing for any structure is the responsibility of the Building Designer per ANSI/TPI 1 Sec.2.
 For more information see these web sites: Alpine: alpineitw.com; TPI: tpinst.org; SBCA: sbccomponents.com; ICC: iccsafe.org; AWC: awc.org

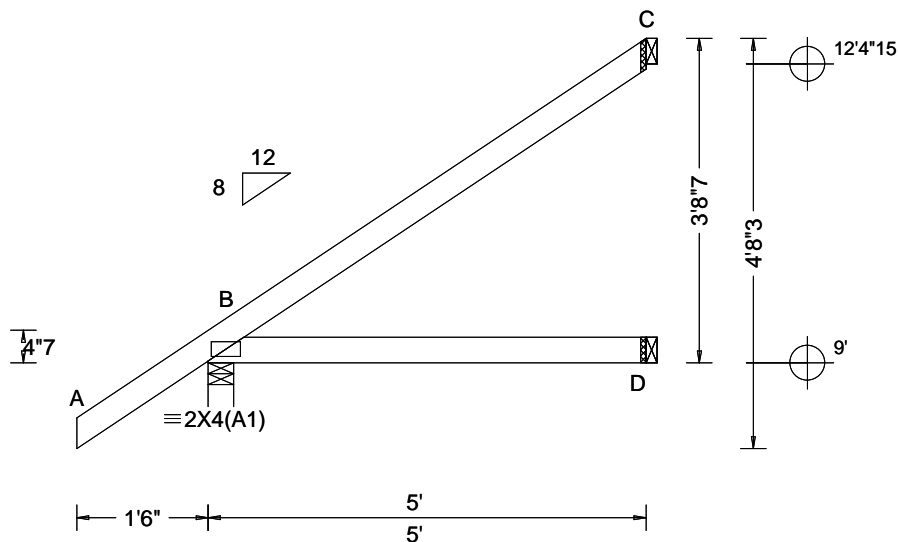

Loading Criteria (psf) TCCL: 20.00 TCDL: 10.00 BCLL: 0.00 BCDL: 10.00 Des Ld: 40.00 NCBCLL: 10.00 Soffit: 2.00 Load Duration: 1.25 Spacing: 24.0 "	Wind Criteria Wind Std: ASCE 7-22 Speed: 130 mph Enclosure: Enclosed Risk Category: II EXP: C Kzt: NA Mean Height: 15.00 ft TCDL: 5.0 psf BCDL: 5.0 psf MWFRS Parallel Dist: 0 to h/2 C&C Dist a: 3.00 ft Loc. from endwall: not in 4.50 ft GCp: 0.18 Wind Duration: 1.60	Snow Criteria (Pg,Pf in PSF) Pg: NA Ct: NA CAT: NA Pf: NA Ce: NA Lu: NA Cs: NA Snow Duration: NA Building Code: FBC 8th Ed. 2023 Res. TPI Std: 2014 Rep Fac: Yes FT/RT:20(0)/10(0) Plate Type(s): WAVE	Defl/CSI Criteria PP Deflection in loc L/defl L/# VERT(LL): NA VERT(CL): NA HORZ(LL): 0.004 B - - HORZ(TL): 0.008 B - - Creep Factor: 2.0 Max TC CSI: 0.380 Max BC CSI: 0.242 Max Web CSI: 0.000 VIEW Ver: 24.02.00D.0611.08	▲ Maximum Reactions (lbs) <table border="1"> <thead> <tr> <th rowspan="2">Loc</th> <th colspan="3">Gravity</th> <th colspan="3">Non-Gravity</th> </tr> <tr> <th>R+</th> <th>/R-</th> <th>/Rh</th> <th>/Rw</th> <th>/U</th> <th>/RL</th> </tr> </thead> <tbody> <tr> <td>B</td> <td>339</td> <td>-</td> <td>-</td> <td>/147</td> <td>/23</td> <td>/145</td> </tr> <tr> <td>D</td> <td>91</td> <td>-</td> <td>-</td> <td>/57</td> <td>-</td> <td>-</td> </tr> <tr> <td>C</td> <td>131</td> <td>-</td> <td>-</td> <td>/104</td> <td>/79</td> <td>-</td> </tr> </tbody> </table>	Loc	Gravity			Non-Gravity			R+	/R-	/Rh	/Rw	/U	/RL	B	339	-	-	/147	/23	/145	D	91	-	-	/57	-	-	C	131	-	-	/104	/79	-
				Loc		Gravity			Non-Gravity																													
R+	/R-	/Rh	/Rw		/U	/RL																																
B	339	-	-	/147	/23	/145																																
D	91	-	-	/57	-	-																																
C	131	-	-	/104	/79	-																																
Wind reactions based on MWFRS B Brg Wid = 3.5 Min Req = 1.5 (Truss) D Brg Wid = 1.5 Min Req = - C Brg Wid = 1.5 Min Req = - Bearing B is a rigid surface. Members not listed have forces less than 375#																																						

Lumber

Top chord: 2x4 SP #2;
 Bot chord: 2x4 SP #2;

Wind

Wind loads based on MWFRS with additional C&C member design.
 Wind loading based on both gable and hip roof types.

Additional Notes

The overall height of this truss excluding overhang is 3-8-7.



COA #0278

02/02/2026
 Florida Certificate of Product Approval #FL 1999

****WARNING** READ AND FOLLOW ALL NOTES ON THIS DRAWING!**
****IMPORTANT** FURNISH THIS DRAWING TO ALL CONTRACTORS INCLUDING THE INSTALLERS**
 Trusses require extreme care in fabricating, handling, shipping, installing and bracing. Refer to and follow the latest edition of BCSI (Building Component Safety Information, by TPI and SBCA) for safety practices prior to performing these functions. Installers shall provide temporary bracing per BCSI. Unless noted otherwise, top chord shall have properly attached structural sheathing and bottom chord shall have a properly attached rigid ceiling. Locations shown for permanent lateral restraint of webs shall have continuous lateral restraint (CLR), installed with diagonal bracing installed on the CLR per BCSI sections B3, B7, or B10, as applicable. Apply plates to each face of truss and position as shown above and on the Joint Details, unless noted otherwise. Refer to drawings 160A-Z for standard plate positions. Refer to job's General Notes page for additional information.
 Alpine, a division of ITW Building Components Group Inc. shall not be responsible for any deviation from this drawing, any failure to build the truss in conformance with ANSI/TPI 1, or for handling, shipping, installation and bracing of trusses. A seal on this drawing or cover page listing this drawing, indicates acceptance of professional engineering responsibility solely for the design shown. The suitability and use of this drawing for any structure is the responsibility of the Building Designer per ANSI/TPI 1 Sec.2.
 For more information see these web sites: Alpine: alpineitw.com; TPI: tpinst.org; SBCA: sbccomponents.com; ICC: iccsafe.org; AWC: awc.org



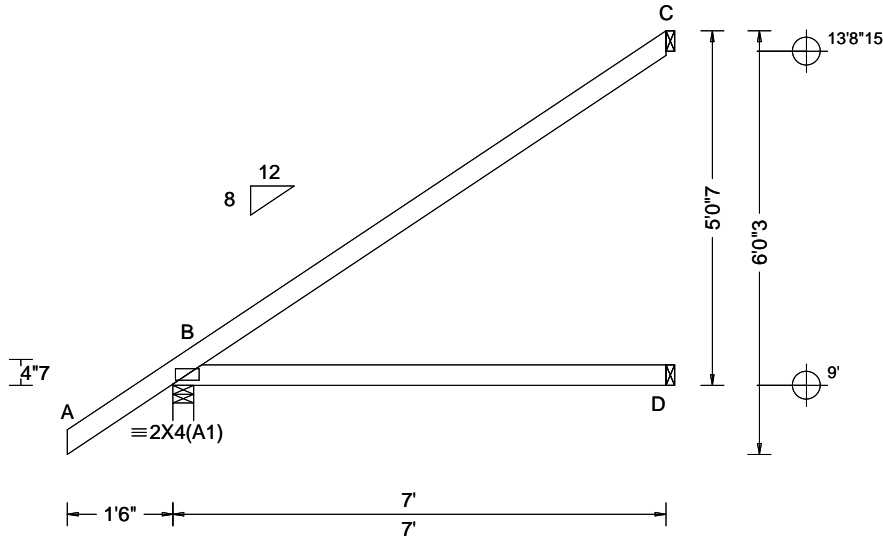

Loading Criteria (psf) TCCL: 20.00 TCCL: 10.00 BCLL: 0.00 BCDL: 10.00 Des Ld: 40.00 NCBCLL: 10.00 Soffit: 2.00 Load Duration: 1.25 Spacing: 24.0 "	Wind Criteria Wind Std: ASCE 7-22 Speed: 130 mph Enclosure: Enclosed Risk Category: II EXP: C Kzt: NA Mean Height: 15.00 ft TCCL: 5.0 psf BCDL: 5.0 psf MWFRS Parallel Dist: h/2 to h C&C Dist a: 3.00 ft Loc. from endwall: not in 4.50 ft GCp: 0.18 Wind Duration: 1.60	Snow Criteria (Pg,Pf in PSF) Pg: NA Ct: NA CAT: NA Pf: NA Ce: NA Lu: NA Cs: NA Snow Duration: NA Building Code: FBC 8th Ed. 2023 Res. TPI Std: 2014 Rep Fac: Yes FT/RT:20(0)/10(0) Plate Type(s): WAVE	Defl/CSI Criteria PP Deflection in loc L/defl L/# VERT(LL): NA VERT(CL): NA HORZ(LL): 0.013 B - - HORZ(TL): 0.027 B - - Creep Factor: 2.0 Max TC CSI: 0.747 Max BC CSI: 0.527 Max Web CSI: 0.000 VIEW Ver: 24.02.00D.0611.08	▲ Maximum Reactions (lbs) <table border="1"> <thead> <tr> <th rowspan="2">Loc</th> <th colspan="3">Gravity</th> <th colspan="3">Non-Gravity</th> </tr> <tr> <th>R+</th> <th>/R-</th> <th>/Rh</th> <th>/Rw</th> <th>/U</th> <th>/RL</th> </tr> </thead> <tbody> <tr> <td>B</td> <td>417</td> <td>/-</td> <td>/-</td> <td>/198</td> <td>/18</td> <td>/192</td> </tr> <tr> <td>D</td> <td>131</td> <td>/-</td> <td>/-</td> <td>/81</td> <td>/-</td> <td>/-</td> </tr> <tr> <td>C</td> <td>193</td> <td>/-</td> <td>/-</td> <td>/147</td> <td>/114</td> <td>/-</td> </tr> </tbody> </table>	Loc	Gravity			Non-Gravity			R+	/R-	/Rh	/Rw	/U	/RL	B	417	/-	/-	/198	/18	/192	D	131	/-	/-	/81	/-	/-	C	193	/-	/-	/147	/114	/-
				Loc		Gravity			Non-Gravity																													
R+	/R-	/Rh	/Rw		/U	/RL																																
B	417	/-	/-	/198	/18	/192																																
D	131	/-	/-	/81	/-	/-																																
C	193	/-	/-	/147	/114	/-																																
Wind reactions based on MWFRS B Brg Wid = 3.5 Min Req = 1.5 (Truss) D Brg Wid = 1.5 Min Req = - C Brg Wid = 1.5 Min Req = - Bearing B is a rigid surface. Members not listed have forces less than 375#																																						

Lumber

Top chord: 2x4 SP #2;
 Bot chord: 2x4 SP #2;

Wind

Wind loads based on MWFRS with additional C&C member design.
 Wind loading based on both gable and hip roof types.

Additional Notes

The overall height of this truss excluding overhang is 5-0-7.

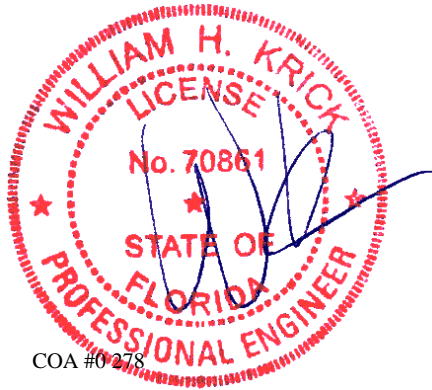

COA #0278

Florida Certificate of Product Approval #FL 1999

****WARNING** READ AND FOLLOW ALL NOTES ON THIS DRAWING!**
****IMPORTANT** FURNISH THIS DRAWING TO ALL CONTRACTORS INCLUDING THE INSTALLERS**
 Trusses require extreme care in fabricating, handling, shipping, installing and bracing. Refer to and follow the latest edition of BCSI (Building Component Safety Information, by TPI and SBCA) for safety practices prior to performing these functions. Installers shall provide temporary bracing per BCSI. Unless noted otherwise, top chord shall have properly attached structural sheathing and bottom chord shall have a properly attached rigid ceiling. Locations shown for permanent lateral restraint of webs shall have continuous lateral restraint (CLR), installed with diagonal bracing installed on the CLR per BCSI sections B3, B7, or B10, as applicable. Apply plates to each face of truss and position as shown above and on the Joint Details, unless noted otherwise. Refer to drawings 160A-Z for standard plate positions. Refer to job's General Notes page for additional information.
 Alpine, a division of ITW Building Components Group Inc. shall not be responsible for any deviation from this drawing, any failure to build the truss in conformance with ANSI/TPI 1, or for handling, shipping, installation and bracing of trusses. A seal on this drawing or cover page listing this drawing, indicates acceptance of professional engineering responsibility solely for the design shown. The suitability and use of this drawing for any structure is the responsibility of the Building Designer per ANSI/TPI 1 Sec.2.
 For more information see these web sites: Alpine: alpineitw.com; TPI: tpinst.org; SBCA: sbccomponents.com; ICC: iccsafe.org; AWC: awc.org



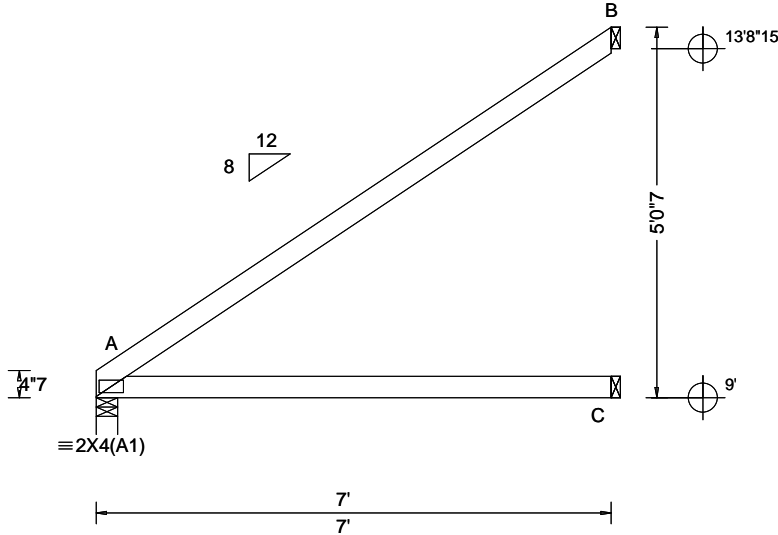

Loading Criteria (psf) TCCL: 20.00 TCDL: 10.00 BCLL: 0.00 BCDL: 10.00 Des Ld: 40.00 NCBCLL: 10.00 Soffit: 2.00 Load Duration: 1.25 Spacing: 24.0 "	Wind Criteria Wind Std: ASCE 7-22 Speed: 130 mph Enclosure: Enclosed Risk Category: II EXP: C Kzt: NA Mean Height: 15.00 ft TCDL: 5.0 psf BCDL: 5.0 psf MWFRS Parallel Dist: h/2 to h C&C Dist a: 3.00 ft Loc. from endwall: not in 9.00 ft GCp: 0.18 Wind Duration: 1.60	Snow Criteria (Pg,Pf in PSF) Pg: NA Ct: NA CAT: NA Pf: NA Ce: NA Lu: NA Cs: NA Snow Duration: NA Building Code: FBC 8th Ed. 2023 Res. TPI Std: 2014 Rep Fac: Yes FT/RT:20(0)/10(0) Plate Type(s): WAVE	Defl/CSI Criteria PP Deflection in loc L/defl L/# VERT(LL): NA VERT(CL): NA HORZ(LL): 0.016 A - - HORZ(TL): 0.033 A - - Creep Factor: 2.0 Max TC CSI: 0.804 Max BC CSI: 0.549 Max Web CSI: 0.000 VIEW Ver: 24.02.00D.0611.08	▲ Maximum Reactions (lbs) <table border="1"> <thead> <tr> <th rowspan="2">Loc</th> <th colspan="3">Gravity</th> <th colspan="3">Non-Gravity</th> </tr> <tr> <th>R+</th> <th>/R-</th> <th>/Rh</th> <th>/Rw</th> <th>/U</th> <th>/RL</th> </tr> </thead> <tbody> <tr> <td>A</td> <td>300</td> <td>-</td> <td>-</td> <td>/187</td> <td>-</td> <td>/164</td> </tr> <tr> <td>C</td> <td>133</td> <td>-</td> <td>-</td> <td>/81</td> <td>-</td> <td>-</td> </tr> <tr> <td>B</td> <td>200</td> <td>-</td> <td>-</td> <td>/147</td> <td>/116</td> <td>-</td> </tr> </tbody> </table>	Loc	Gravity			Non-Gravity			R+	/R-	/Rh	/Rw	/U	/RL	A	300	-	-	/187	-	/164	C	133	-	-	/81	-	-	B	200	-	-	/147	/116	-
				Loc		Gravity			Non-Gravity																													
R+	/R-	/Rh	/Rw		/U	/RL																																
A	300	-	-	/187	-	/164																																
C	133	-	-	/81	-	-																																
B	200	-	-	/147	/116	-																																
Wind reactions based on MWFRS A Brg Wid = 3.5 Min Req = 1.5 (Truss) C Brg Wid = 1.5 Min Req = - B Brg Wid = 1.5 Min Req = - Bearing A is a rigid surface. Members not listed have forces less than 375#																																						

Lumber

Top chord: 2x4 SP #2;
 Bot chord: 2x4 SP #2;

Wind

Wind loads based on MWFRS with additional C&C member design.
 Wind loading based on both gable and hip roof types.

Additional Notes

The overall height of this truss excluding overhang is 5-0-7.



COA #0278

Florida Certificate of Product Approval #FL 1999

****WARNING** READ AND FOLLOW ALL NOTES ON THIS DRAWING!**
****IMPORTANT** FURNISH THIS DRAWING TO ALL CONTRACTORS INCLUDING THE INSTALLERS**
 Trusses require extreme care in fabricating, handling, shipping, installing and bracing. Refer to and follow the latest edition of BCSI (Building Component Safety Information, by TPI and SBCA) for safety practices prior to performing these functions. Installers shall provide temporary bracing per BCSI. Unless noted otherwise, top chord shall have properly attached structural sheathing and bottom chord shall have a properly attached rigid ceiling. Locations shown for permanent lateral restraint of webs shall have continuous lateral restraint (CLR), installed with diagonal bracing installed on the CLR per BCSI sections B3, B7, or B10, as applicable. Apply plates to each face of truss and position as shown above and on the Joint Details, unless noted otherwise. Refer to drawings 160A-Z for standard plate positions. Refer to job's General Notes page for additional information.
 Alpine, a division of ITW Building Components Group Inc. shall not be responsible for any deviation from this drawing, any failure to build the truss in conformance with ANSI/TPI 1, or for handling, shipping, installation and bracing of trusses. A seal on this drawing or cover page listing this drawing, indicates acceptance of professional engineering responsibility solely for the design shown. The suitability and use of this drawing for any structure is the responsibility of the Building Designer per ANSI/TPI 1 Sec.2.
 For more information see these web sites: Alpine: alpineitw.com; TPI: tpinst.org; SBCA: sbccomponents.com; ICC: iccsafe.org; AWC: awc.org



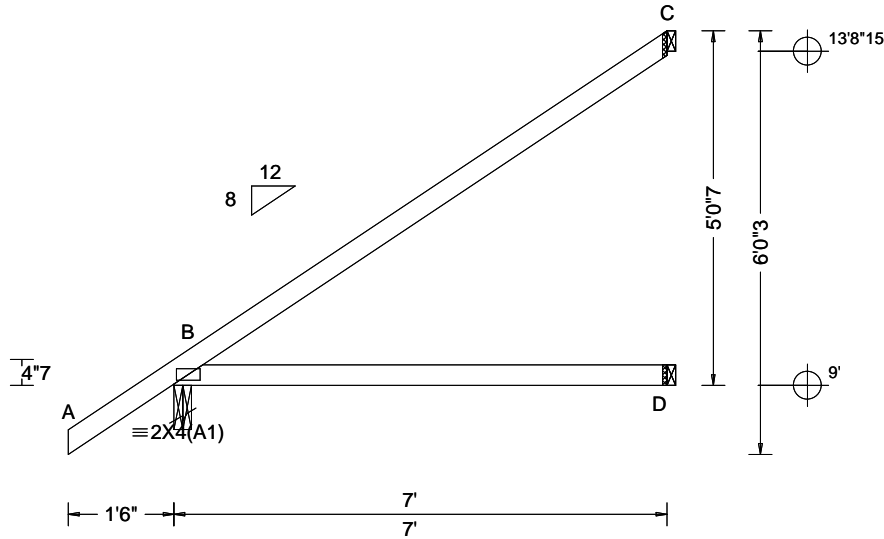

Loading Criteria (psf) TCLL: 20.00 TCCL: 10.00 BCLL: 0.00 BCDL: 10.00 Des Ld: 40.00 NCBCLL: 10.00 Soffit: 2.00 Load Duration: 1.25 Spacing: 24.0 "	Wind Criteria Wind Std: ASCE 7-22 Speed: 130 mph Enclosure: Enclosed Risk Category: II EXP: C Kzt: NA Mean Height: 15.00 ft TCCL: 5.0 psf BCDL: 5.0 psf MWFRS Parallel Dist: h/2 to h C&C Dist a: 3.00 ft Loc. from endwall: not in 4.50 ft GCp: 0.18 Wind Duration: 1.60	Snow Criteria (Pg,Pf in PSF) Pg: NA Ct: NA CAT: NA Pf: NA Ce: NA Lu: NA Cs: NA Snow Duration: NA Building Code: FBC 8th Ed. 2023 Res. TPI Std: 2014 Rep Fac: Yes FT/RT:20(0)/10(0) Plate Type(s): WAVE	Defl/CSI Criteria PP Deflection in loc L/defl L/# VERT(LL): NA VERT(CL): NA HORZ(LL): 0.014 B - - HORZ(TL): 0.028 B - - Creep Factor: 2.0 Max TC CSI: 0.751 Max BC CSI: 0.530 Max Web CSI: 0.000 VIEW Ver: 24.02.00D.0611.08	▲ Maximum Reactions (lbs) <table border="1"> <thead> <tr> <th rowspan="2">Loc</th> <th colspan="3">Gravity</th> <th colspan="3">Non-Gravity</th> </tr> <tr> <th>R+</th> <th>/R-</th> <th>/Rh</th> <th>/Rw</th> <th>/U</th> <th>/RL</th> </tr> </thead> <tbody> <tr> <td>B</td> <td>416</td> <td>-</td> <td>-</td> <td>/198</td> <td>/18</td> <td>/192</td> </tr> <tr> <td>D</td> <td>131</td> <td>-</td> <td>-</td> <td>/81</td> <td>-</td> <td>-</td> </tr> <tr> <td>C</td> <td>193</td> <td>-</td> <td>-</td> <td>/147</td> <td>/114</td> <td>-</td> </tr> </tbody> </table>	Loc	Gravity			Non-Gravity			R+	/R-	/Rh	/Rw	/U	/RL	B	416	-	-	/198	/18	/192	D	131	-	-	/81	-	-	C	193	-	-	/147	/114	-
				Loc		Gravity			Non-Gravity																													
R+	/R-	/Rh	/Rw		/U	/RL																																
B	416	-	-	/198	/18	/192																																
D	131	-	-	/81	-	-																																
C	193	-	-	/147	/114	-																																
Wind reactions based on MWFRS B Brg Wid = 3.0 Min Req = 1.5 (Truss) D Brg Wid = 1.5 Min Req = - C Brg Wid = 1.5 Min Req = - Bearing B is a rigid surface. Members not listed have forces less than 375#																																						

Lumber

Top chord: 2x4 SP #2;
 Bot chord: 2x4 SP #2;

Wind

Wind loads based on MWFRS with additional C&C member design.
 Wind loading based on both gable and hip roof types.

Additional Notes

The overall height of this truss excluding overhang is 5-0-7.

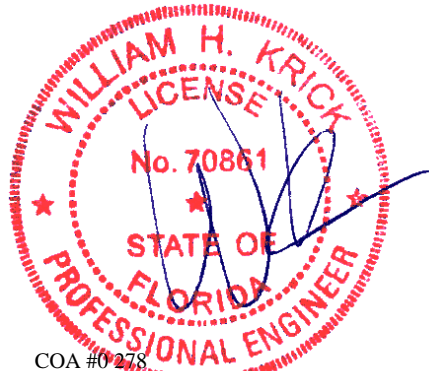

COA #0278

02/02/2026 Florida Certificate of Product Approval #FL 1999

****WARNING** READ AND FOLLOW ALL NOTES ON THIS DRAWING!**
****IMPORTANT** FURNISH THIS DRAWING TO ALL CONTRACTORS INCLUDING THE INSTALLERS**
 Trusses require extreme care in fabricating, handling, shipping, installing and bracing. Refer to and follow the latest edition of BCSI (Building Component Safety Information, by TPI and SBCA) for safety practices prior to performing these functions. Installers shall provide temporary bracing per BCSI. Unless noted otherwise, top chord shall have properly attached structural sheathing and bottom chord shall have a properly attached rigid ceiling. Locations shown for permanent lateral restraint of webs shall have continuous lateral restraint (CLR), installed with diagonal bracing installed on the CLR per BCSI sections B3, B7, or B10, as applicable. Apply plates to each face of truss and position as shown above and on the Joint Details, unless noted otherwise. Refer to drawings 160A-Z for standard plate positions. Refer to job's General Notes page for additional information.
 Alpine, a division of ITW Building Components Group Inc. shall not be responsible for any deviation from this drawing, any failure to build the truss in conformance with ANSI/TPI 1, or for handling, shipping, installation and bracing of trusses. A seal on this drawing or cover page listing this drawing, indicates acceptance of professional engineering responsibility solely for the design shown. The suitability and use of this drawing for any structure is the responsibility of the Building Designer per ANSI/TPI 1 Sec.2.
 For more information see these web sites: Alpine: alpineitw.com; TPI: tpinst.org; SBCA: sbccomponents.com; ICC: iccsafe.org; AWC: awc.org



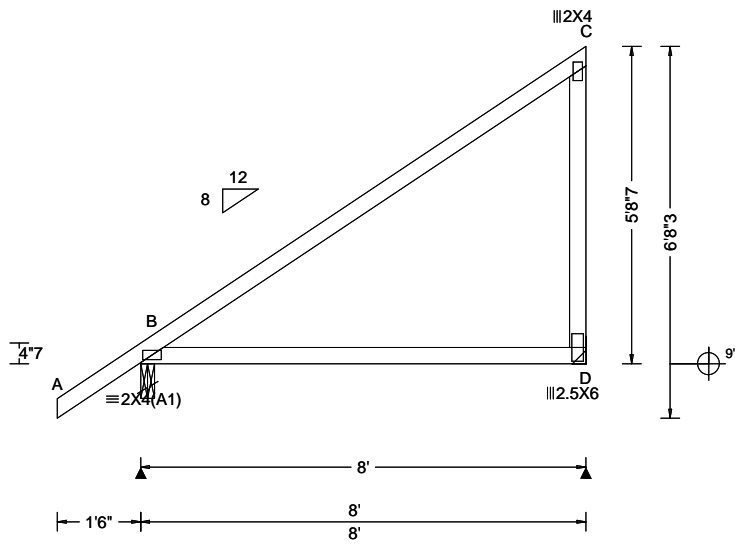

Loading Criteria (psf)	Wind Criteria	Snow Criteria (Pg,Pf in PSF)	Defl/CSI Criteria	▲ Maximum Reactions (lbs)
TCLL: 20.00 TCDL: 10.00 BCLL: 0.00 BCDL: 10.00 Des Ld: 40.00 NCBCLL: 10.00 Soffit: 2.00 Load Duration: 1.25 Spacing: 24.0 "	Wind Std: ASCE 7-22 Speed: 130 mph Enclosure: Enclosed Risk Category: II EXP: C Kzt: NA Mean Height: 15.00 ft TCDL: 5.0 psf BCDL: 5.0 psf MWFRS Parallel Dist: h/2 to h C&C Dist a: 3.00 ft Loc. from endwall: not in 9.00 ft GCpi: 0.18 Wind Duration: 1.60	Pg: NA Ct: NA CAT: NA Pf: NA Ce: NA Lu: NA Cs: NA Snow Duration: NA Building Code: FBC 8th Ed. 2023 Res. TPI Std: 2014 Rep Fac: Yes FT/RT:20(0)/10(0) Plate Type(s): WAVE	PP Deflection in loc L/defl L/# VERT(LL): NA VERT(CL): NA HORZ(LL): 0.022 B - - HORZ(TL): 0.041 B - - Creep Factor: 2.0 Max TC CSI: 0.425 Max BC CSI: 0.666 Max Web CSI: 0.131 VIEW Ver: 24.02.00D.0611.08	Gravity Loc R+ / R- / Rh / Rw / U / RL Non-Gravity B 470 /- /- /224 /17 /216 D 388 /- /- /262 /113 /- Wind reactions based on MWFRS B Brg Wid = 3.0 Min Req = 1.5 (Truss) D Brg Wid = - Min Req = - Bearing B is a rigid surface. Members not listed have forces less than 375#

Lumber
Top chord: 2x4 SP M-31;
Bot chord: 2x4 SP #2;
Webs: 2x4 SP #3;

Hangers / Ties
Simpson Construction Hardware is specified based on the most current information provided by Simpson Strong-Tie. Please refer to the most recent Simpson Strong-Tie catalog for additional information.
Recommended hanger connections are based on manufacturer tested capacities and calculations. Conditions may exist that require different connections than indicated. Refer to manufacturer publication for additional information.
Hanger specified assumes connection to supporting chord is located a minimum of five times the depth of the supporting chord from any unsupported end, unless unsupported chord end has 85% plating coverage.
Bearing at location x=7'9" uses the following support conditions: 7'9"
Bearing D (7'9", 9") LUS24
Supporting Member: (1)2x6 SP #2
(4) 0.148"x3" nails into supporting member,
(2) 0.148"x3" nails into supported member.

Loading
Truss passed check for 20 psf additional bottom chord live load in areas with 42"-high x 24"-wide clearance.

Wind
Wind loads based on MWFRS with additional C&C member design.
Right end vertical not exposed to wind pressure.
Wind loading based on both gable and hip roof types.

Additional Notes
The overall height of this truss excluding overhang is 5-8-7.



COA #0 278
02/02/2026
Florida Certificate of Product Approval #FL 1999

****WARNING** READ AND FOLLOW ALL NOTES ON THIS DRAWING!**
****IMPORTANT** FURNISH THIS DRAWING TO ALL CONTRACTORS INCLUDING THE INSTALLERS**
Trusses require extreme care in fabricating, handling, shipping, installing and bracing. Refer to and follow the latest edition of BCSI (Building Component Safety Information, by TPI and SBCA) for safety practices prior to performing these functions. Installers shall provide temporary bracing per BCSI. Unless noted otherwise, top chord shall have properly attached structural sheathing and bottom chord shall have a properly attached rigid ceiling. Locations shown for permanent lateral restraint of webs shall have continuous lateral restraint (CLR), installed with diagonal bracing installed on the CLR per BCSI sections B3, B7, or B10, as applicable. Apply plates to each face of truss and position as shown above and on the Joint Details, unless noted otherwise. Refer to drawings 160A-Z for standard plate positions. Refer to job's General Notes page for additional information.
Alpine, a division of ITW Building Components Group Inc. shall not be responsible for any deviation from this drawing, any failure to build the truss in conformance with ANSI/TPI 1, or for handling, shipping, installation and bracing of trusses. A seal on this drawing or cover page listing this drawing, indicates acceptance of professional engineering responsibility solely for the design shown. The suitability and use of this drawing for any structure is the responsibility of the Building Designer per ANSI/TPI 1 Sec.2.
For more information see these web sites: Alpine: alpineitw.com; TPI: tpinst.org; SBCA: sbccomponents.com; ICC: iccsafe.org; AWC: awc.org



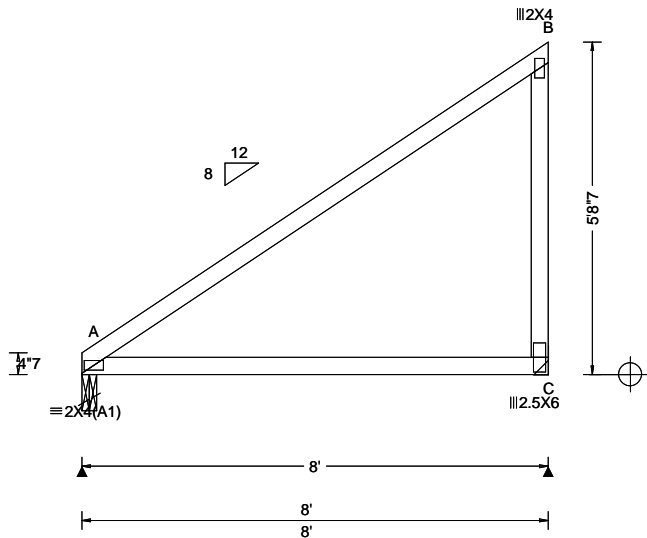

Loading Criteria (psf) TCLL: 20.00 TCDL: 10.00 BCLL: 0.00 BCDL: 10.00 Des Ld: 40.00 NCBCLL: 10.00 Soffit: 2.00 Load Duration: 1.25 Spacing: 24.0 "	Wind Criteria Wind Std: ASCE 7-22 Speed: 130 mph Enclosure: Enclosed Risk Category: II EXP: C Kzt: NA Mean Height: 15.00 ft TCDL: 5.0 psf BCDL: 5.0 psf MWFRS Parallel Dist: h/2 to h C&C Dist a: 3.00 ft Loc. from endwall: not in 9.00 ft GCpi: 0.18 Wind Duration: 1.60	Snow Criteria (Pg,Pf in PSF) Pg: NA Ct: NA CAT: NA Pf: NA Ce: NA Lu: NA Cs: NA Snow Duration: NA Building Code: FBC 8th Ed. 2023 Res. TPI Std: 2014 Rep Fac: Yes FT/RT:20(0)/10(0) Plate Type(s): WAVE	Defl/CSI Criteria PP Deflection in loc L/defl L/# VERT(LL): NA VERT(CL): NA HORZ(LL): 0.021 A - - HORZ(TL): 0.043 A - - Creep Factor: 2.0 Max TC CSI: 0.439 Max BC CSI: 0.684 Max Web CSI: 0.133 VIEW Ver: 24.02.00D.0611.08	▲ Maximum Reactions (lbs) Gravity Non-Gravity Loc R+ / R- / Rh / Rw / U / RL A 341 /- /- /213 /- /187 C 331 /- /- /262 /117 /- Wind reactions based on MWFRS A Brg Wid = 3.0 Min Req = 1.5 (Truss) C Brg Wid = - Min Req = - Bearing A is a rigid surface. Members not listed have forces less than 375#
--	--	--	---	--

Lumber
Top chord: 2x4 SP M-31;
Bot chord: 2x4 SP #2;
Webs: 2x4 SP #3;

Hangers / Ties
Simpson Construction Hardware is specified based on the most current information provided by Simpson Strong-Tie. Please refer to the most recent Simpson Strong-Tie catalog for additional information.
Recommended hanger connections are based on manufacturer tested capacities and calculations. Conditions may exist that require different connections than indicated. Refer to manufacturer publication for additional information.
Hanger specified assumes connection to supporting chord is located a minimum of five times the depth of the supporting chord from any unsupported end, unless unsupported chord end has 85% plating coverage.
Bearing at location x=7'9" uses the following support conditions: 7'9"
Bearing C (7'9", 9") LUS24
Supporting Member: (1)2x6 SP #2
(4) 0.148"x3" nails into supporting member,
(2) 0.148"x3" nails into supported member.

Additional Notes
The overall height of this truss excluding overhang is 5-8-7.

Wind
Wind loads based on MWFRS with additional C&C member design.
Right end vertical not exposed to wind pressure.
Wind loading based on both gable and hip roof types.



****WARNING** READ AND FOLLOW ALL NOTES ON THIS DRAWING!**
****IMPORTANT** FURNISH THIS DRAWING TO ALL CONTRACTORS INCLUDING THE INSTALLERS**
Trusses require extreme care in fabricating, handling, shipping, installing and bracing. Refer to and follow the latest edition of BCSI (Building Component Safety Information, by TPI and SBCA) for safety practices prior to performing these functions. Installers shall provide temporary bracing per BCSI. Unless noted otherwise, top chord shall have properly attached structural sheathing and bottom chord shall have a properly attached rigid ceiling. Locations shown for permanent lateral restraint of webs shall have continuous lateral restraint (CLR), installed with diagonal bracing installed on the CLR per BCSI sections B3, B7, or B10, as applicable. Apply plates to each face of truss and position as shown above and on the Joint Details, unless noted otherwise. Refer to drawings 160A-Z for standard plate positions. Refer to job's General Notes page for additional information.
Alpine, a division of ITW Building Components Group Inc. shall not be responsible for any deviation from this drawing, any failure to build the truss in conformance with ANSI/TPI 1, or for handling, shipping, installation and bracing of trusses. A seal on this drawing or cover page listing this drawing, indicates acceptance of professional engineering responsibility solely for the design shown. The suitability and use of this drawing for any structure is the responsibility of the Building Designer per ANSI/TPI 1 Sec.2.
For more information see these web sites: Alpine: alpineitw.com; TPI: tpinst.org; SBCA: sbccomponents.com; ICC: iccsafe.org; AWC: awc.org



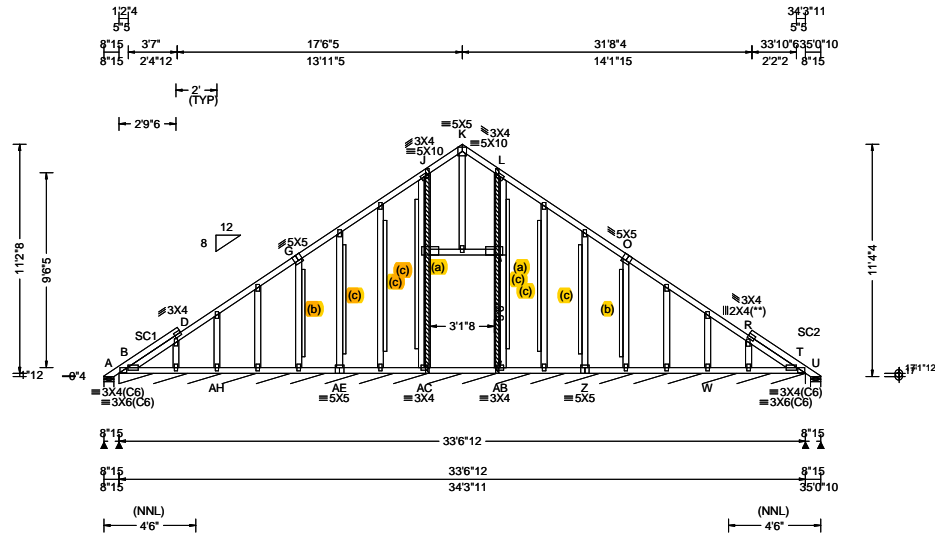

Loading Criteria (psf) TCCL: 20.00 TCCL: 10.00 BCLL: 0.00 BCLL: 10.00 Des Ld: 40.00 NCBCLL: 10.00 Soffit: 2.00 Load Duration: 1.25 Spacing: 24.0 "	Wind Criteria Wind Std: ASCE 7-22 Speed: 130 mph Enclosure: Enclosed Risk Category: II EXP: C Kzt: NA Mean Height: 22.69 ft TCCL: 5.0 psf BCLL: 5.0 psf MWFRS Parallel Dist: 0 to h/2 C&C Dist a: 4.58 ft Loc. from endwall: not in 9.00 ft GCpi: 0.18 Wind Duration: 1.60	Snow Criteria (Pg,Pf in PSF) Pg: NA Ct: NA CAT: NA Pf: NA Ce: NA Lu: NA Cs: NA Snow Duration: NA Building Code: FBC 8th Ed. 2023 Res. TPI Std: 2014 Rep Fac: Yes FT/RT:20(0)/10(0) Plate Type(s): WAVE	Defl/CSI Criteria PP Deflection in loc L/defl L/# VERT(LL): 0.003 K 999 240 VERT(CL): 0.013 K 999 180 HORZ(LL): 0.003 L - - HORZ(TL): 0.018 M - - Creep Factor: 2.0 Max TC CSI: 0.142 Max BC CSI: 0.088 Max Web CSI: 0.993 VIEW Ver: 24.02.00D.0611.08	▲ Maximum Reactions (lbs), or *=PLF <table border="1" style="width:100%; border-collapse: collapse;"> <thead> <tr> <th rowspan="2">Loc</th> <th colspan="3">Gravity</th> <th colspan="3">Non-Gravity</th> </tr> <tr> <th>R+</th> <th>/R-</th> <th>/Rh</th> <th>/Rw</th> <th>/U</th> <th>/RL</th> </tr> </thead> <tbody> <tr> <td>A</td> <td>-</td> <td>/-38</td> <td>/-</td> <td>/212</td> <td>/220</td> <td>/336</td> </tr> <tr> <td>B*</td> <td>88</td> <td>/-</td> <td>/-</td> <td>/52</td> <td>/17</td> <td>/-</td> </tr> <tr> <td>U</td> <td>-</td> <td>/-24</td> <td>/-</td> <td>/33</td> <td>/30</td> <td>/-</td> </tr> <tr> <td>AH</td> <td></td> <td>/-108</td> <td></td> <td></td> <td></td> <td></td> </tr> <tr> <td>W</td> <td></td> <td>/-104</td> <td></td> <td></td> <td></td> <td></td> </tr> </tbody> </table> <p>Wind reactions based on MWFRS A Brg Wid = 5.9 Min Req = 1.5 (Truss) B Brg Wid = 402 Min Req = - U Brg Wid = 5.9 Min Req = 1.5 (Truss) Bearings A, B, & U are a rigid surface. Members not listed have forces less than 375# Maximum Top Chord Forces Per Ply (lbs)</p> <table border="1" style="width:100%; border-collapse: collapse;"> <thead> <tr> <th>Chords</th> <th>Tens.</th> <th>Comp.</th> </tr> </thead> <tbody> <tr> <td>A - B</td> <td>409</td> <td>-398</td> </tr> </tbody> </table>	Loc	Gravity			Non-Gravity			R+	/R-	/Rh	/Rw	/U	/RL	A	-	/-38	/-	/212	/220	/336	B*	88	/-	/-	/52	/17	/-	U	-	/-24	/-	/33	/30	/-	AH		/-108					W		/-104					Chords	Tens.	Comp.	A - B	409	-398
Loc	Gravity			Non-Gravity																																																						
	R+	/R-	/Rh	/Rw	/U	/RL																																																				
A	-	/-38	/-	/212	/220	/336																																																				
B*	88	/-	/-	/52	/17	/-																																																				
U	-	/-24	/-	/33	/30	/-																																																				
AH		/-108																																																								
W		/-104																																																								
Chords	Tens.	Comp.																																																								
A - B	409	-398																																																								

Lumber
 Top chord: 2x4 SP #2;
 Bot chord: 2x4 SP #2;
 Webs: 2x4 SP #3;
 Stack Chord: SC1 2x4 SP #2;
 Stack Chord: SC2 2x4 SP #2;

Plating Notes
 All plates are 2X4 except as noted.
 (**) 1 plate(s) require special positioning. Refer to scaled plate plot details for special positioning requirements.

Loading
 Gable end supports 8" max rake overhang. Top chord must not be cut or notched.

Wind
 Wind loads based on MWFRS.
 Wind loading based on both gable and hip roof types.
 Gable meets L/120 deflection criteria for wind load applied to face. Calculated deflection ratio is L/203.
 Refer to DWG PB160220723 for piggyback details.

Gable Reinforcement
 (a) 2x4 "T" reinforcement. Any species and grade. Full truss height along web member. Attach to the wide face with 10d (0.131"x3",min.) nails @ 4" oc in the web plus (2)10d (0.131"x3",min.) nails in each chord.
 (b) 2x4 "L" reinforcement. Any species and grade. 80% length of web member. Attach with 10d (0.131"x3",min.) nails @ 2" oc at each end for the first 18" and then 4" oc for the remainder.
 (c) 2x6 "L" reinforcement. Any species and grade. 80% length of web member. Attach with 10d (0.131"x3",min.) nails @ 2" oc at each end for the first 18" and then 4" oc for the remainder.



COA #0278
 02/02/2026
 Florida Certificate of Product Approval #FL 1999

****WARNING** READ AND FOLLOW ALL NOTES ON THIS DRAWING!**
****IMPORTANT** FURNISH THIS DRAWING TO ALL CONTRACTORS INCLUDING THE INSTALLERS**
 Trusses require extreme care in fabricating, handling, shipping, installing and bracing. Refer to and follow the latest edition of BCSI (Building Component Safety Information, by TPI and SBCA) for safety practices prior to performing these functions. Installers shall provide temporary bracing per BCSI. Unless noted otherwise, top chord shall have properly attached structural sheathing and bottom chord shall have a properly attached rigid ceiling. Locations shown for permanent lateral restraint of webs shall have continuous lateral restraint (CLR), installed with diagonal bracing installed on the CLR per BCSI sections B3, B7, or B10, as applicable. Apply plates to each face of truss and position as shown above and on the Joint Details, unless noted otherwise. Refer to drawings 160A-Z for standard plate positions. Refer to job's General Notes page for additional information.
 Alpine, a division of ITW Building Components Group Inc. shall not be responsible for any deviation from this drawing, any failure to build the truss in conformance with ANSI/TPI 1, or for handling, shipping, installation and bracing of trusses. A seal on this drawing or cover page listing this drawing, indicates acceptance of professional engineering responsibility solely for the design shown. The suitability and use of this drawing for any structure is the responsibility of the Building Designer per ANSI/TPI 1 Sec.2.
 For more information see these web sites: Alpine: alpineitw.com; TPI: tpinst.org; SBCA: sbccomponents.com; ICC: iccsafe.org; AWC: awc.org



SEQN: 430635	GABL	Ply: 1	Job Number: 26-3432	Cust: R215 JRef: 1YH82150009 T12
FROM: CDM		Qty: 1	MOORE	DrwNo: 030.26.1739.11337
Page 2 of 2			Truss Label: PB01	GA / WHK 01/30/2026

Additional Notes

Exposed portion of gable face shall be reinforced with sheathing and the wind pressures shall be transferred into lateral diaphragms. Connections and designs for diaphragms is the responsibility of the Building Designer in accordance with ANSI/TPI 1.

Stacked top chord must NOT be notched or cut in area (NNL). Dropped top chord braced at 24" oc intervals. Attach stacked top chord (SC) to dropped top chord in notchable area using 3x4 tie-plates 24" oc. Center plate on stacked/dropped chord interface, plate length perpendicular to chord length. Splice top chord in notchable area using 3x6.

The overall height of this truss excluding overhang is 11-4-4.



COA #0278

02/02/2026
Florida Certificate of Product Approval #FL 1999

****WARNING** READ AND FOLLOW ALL NOTES ON THIS DRAWING!**
****IMPORTANT** FURNISH THIS DRAWING TO ALL CONTRACTORS INCLUDING THE INSTALLERS**
 Trusses require extreme care in fabricating, handling, shipping, installing and bracing. Refer to and follow the latest edition of BCSI (Building Component Safety Information, by TPI and SBCA) for safety practices prior to performing these functions. Installers shall provide temporary bracing per BCSI. Unless noted otherwise, top chord shall have properly attached structural sheathing and bottom chord shall have a properly attached rigid ceiling. Locations shown for permanent lateral restraint of webs shall have continuous lateral restraint (CLR), installed with diagonal bracing installed on the CLR per BCSI sections B3, B7, or B10, as applicable. Apply plates to each face of truss and position as shown above and on the Joint Details, unless noted otherwise. Refer to drawings 160A-Z for standard plate positions. Refer to job's General Notes page for additional information.
 Alpine, a division of ITW Building Components Group Inc. shall not be responsible for any deviation from this drawing, any failure to build the truss in conformance with ANSI/TPI 1, or for handling, shipping, installation and bracing of trusses. A seal on this drawing or cover page listing this drawing, indicates acceptance of professional engineering responsibility solely for the design shown. The suitability and use of this drawing for any structure is the responsibility of the Building Designer per ANSI/TPI 1 Sec.2.
 For more information see these web sites: Alpine: alpineitw.com; TPI: tpinst.org; SBCA: sbcacomponents.com; ICC: iccsafe.org; AWC: awc.org



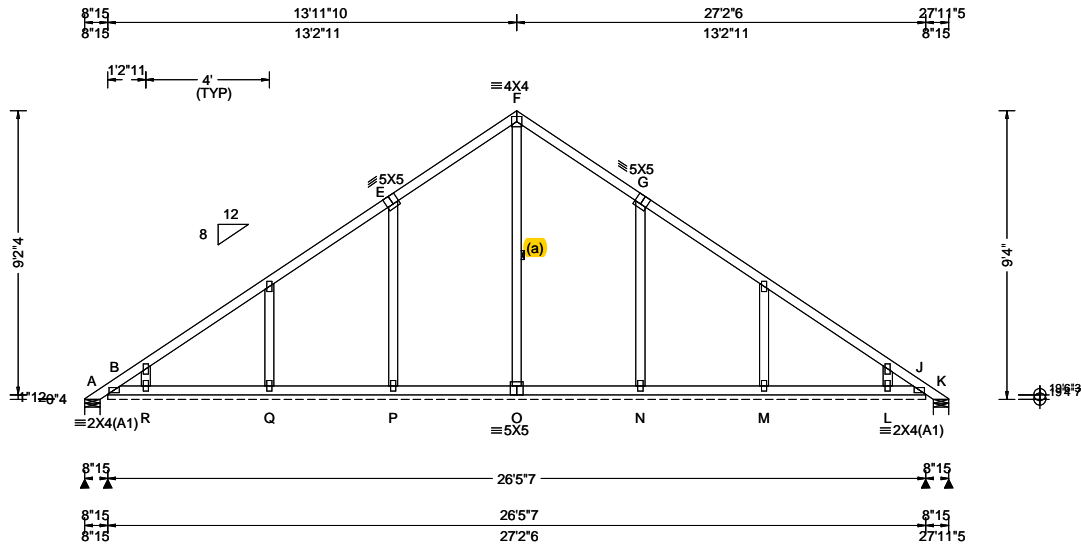

Loading Criteria (psf) TCLL: 20.00 TCDL: 10.00 BCLL: 0.00 BCDL: 10.00 Des Ld: 40.00 NCBCLL: 10.00 Soffit: 2.00 Load Duration: 1.25 Spacing: 24.0 "	Wind Criteria Wind Std: ASCE 7-22 Speed: 130 mph Enclosure: Enclosed Risk Category: II EXP: C Kzt: NA Mean Height: 18.54 ft TCDL: 5.0 psf BCDL: 5.0 psf MWFRS Parallel Dist: h/2 to h C&C Dist a: 4.22 ft Loc. from endwall: not in 13.00 ft GCp: 0.18 Wind Duration: 1.60	Snow Criteria (Pg,Pf in PSF) Pg: NA Ct: NA CAT: NA Pf: NA Ce: NA Lu: NA Cs: NA Snow Duration: NA Building Code: FBC 8th Ed. 2023 Res. TPI Std: 2014 Rep Fac: Yes FT/RT:20(0)/10(0) Plate Type(s): WAVE	Defl/CSI Criteria PP Deflection in loc L/defl L/# VERT(LL): 0.002 G 999 240 VERT(CL): 0.003 G 999 180 HORZ(LL): 0.001 J - - HORZ(TL): 0.009 G - - Creep Factor: 2.0 Max TC CSI: 0.209 Max BC CSI: 0.079 Max Web CSI: 0.219 VIEW Ver: 24.02.00D.0611.08	▲ Maximum Reactions (lbs), or *=PLF Gravity Loc R+ / R- / Rh / Rw / U / RL Non-Gravity A 25 /- /- /179 /160 /289 B* 69 /- /- /54 /22 /- K 25 /- /- /17 /4 /- R /-132 Q /-146 P /-168 N /-168 M /-146 L /-132 Wind reactions based on MWFRS A Brg Wid = 5.9 Min Req = 1.5 (Truss) B Brg Wid = 317 Min Req = - K Brg Wid = 5.9 Min Req = 1.5 (Truss) Bearings A, B, & K are a rigid surface. Members not listed have forces less than 375#
--	--	--	---	---

Lumber

Top chord: 2x4 SP #2;
Bot chord: 2x4 SP #2;
Webs: 2x4 SP #3;

Bracing

(a) Continuous lateral restraint equally spaced on member.

Plating Notes

All plates are 2X4 except as noted.

Wind

Wind loads based on MWFRS with additional C&C member design.
Wind loading based on both gable and hip roof types.

Additional Notes

Refer to DWG PB160220723 for piggyback details.
The overall height of this truss excluding overhang is 9-4-0.

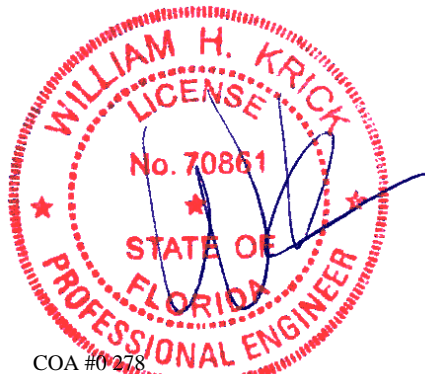

COA #0278

02/02/2026 Florida Certificate of Product Approval #FL 1999

****WARNING** READ AND FOLLOW ALL NOTES ON THIS DRAWING!**
****IMPORTANT** FURNISH THIS DRAWING TO ALL CONTRACTORS INCLUDING THE INSTALLERS**
Trusses require extreme care in fabricating, handling, shipping, installing and bracing. Refer to and follow the latest edition of BCSI (Building Component Safety Information, by TPI and SBCA) for safety practices prior to performing these functions. Installers shall provide temporary bracing per BCSI. Unless noted otherwise, top chord shall have properly attached structural sheathing and bottom chord shall have a properly attached rigid ceiling. Locations shown for permanent lateral restraint of webs shall have continuous lateral restraint (CLR), installed with diagonal bracing installed on the CLR per BCSI sections B3, B7, or B10, as applicable. Apply plates to each face of truss and position as shown above and on the Joint Details, unless noted otherwise. Refer to drawings 160A-Z for standard plate positions. Refer to job's General Notes page for additional information.
Alpine, a division of ITW Building Components Group Inc. shall not be responsible for any deviation from this drawing, any failure to build the truss in conformance with ANSI/TPI 1, or for handling, shipping, installation and bracing of trusses. A seal on this drawing or cover page listing this drawing, indicates acceptance of professional engineering responsibility solely for the design shown. The suitability and use of this drawing for any structure is the responsibility of the Building Designer per ANSI/TPI 1 Sec.2.
For more information see these web sites: Alpine: alpineitw.com; TPI: tpinst.org; SBCA: sbcacomponents.com; ICC: iccsafe.org; AWC: awc.org



SEQN: 430556 FROM: CDM	HIPS Ply: 1 Qty: 1	Job Number: 26-3432 MOORE Truss Label: PB03	Cust: R215 JRef: 1YH82150009 T11 DrwNo: 030.26.1739.20870 GA / WHK 01/30/2026
---------------------------	--------------------------	---	---

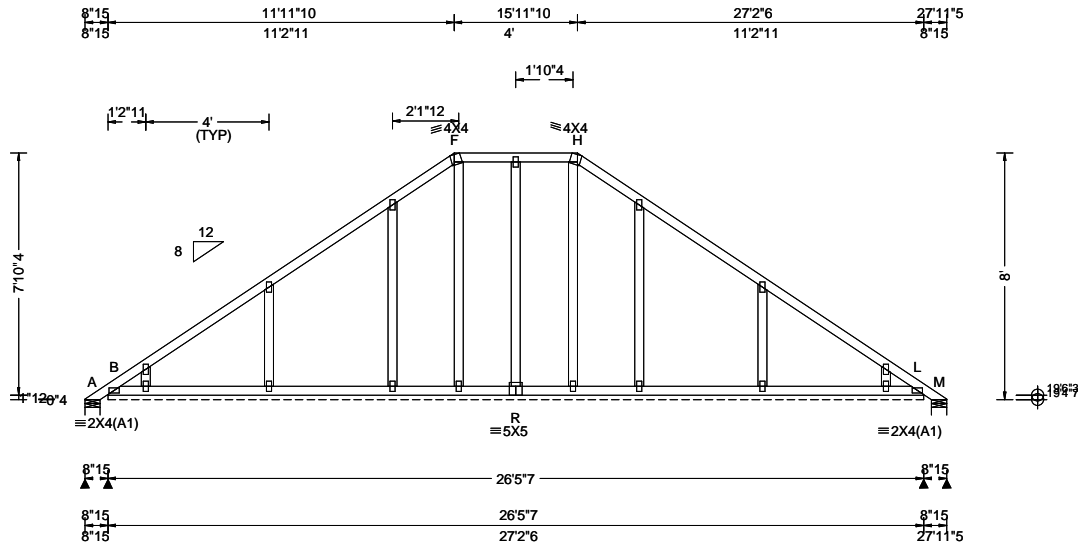

Loading Criteria (psf) TCLL: 20.00 TCCL: 10.00 BCLL: 0.00 BCDL: 10.00 Des Ld: 40.00 NCBCLL: 10.00 Soffit: 2.00 Load Duration: 1.25 Spacing: 24.0 "	Wind Criteria Wind Std: ASCE 7-22 Speed: 130 mph Enclosure: Enclosed Risk Category: II EXP: C Kzt: NA Mean Height: 17.87 ft TCCL: 5.0 psf BCDL: 5.0 psf MWFRS Parallel Dist: h to 2h C&C Dist a: 4.22 ft Loc. from endwall: not in 13.00 ft GCp: 0.18 Wind Duration: 1.60	Snow Criteria (Pg,Pf in PSF) Pg: NA Ct: NA CAT: NA Pf: NA Ce: NA Lu: NA Cs: NA Snow Duration: NA Building Code: FBC 8th Ed. 2023 Res. TPI Std: 2014 Rep Fac: Yes FT/RT:20(0)/10(0) Plate Type(s): WAVE	Defl/CSI Criteria PP Deflection in loc L/defl L/# VERT(LL): 0.001 I 999 240 VERT(CL): 0.002 I 999 180 HORZ(LL): 0.001 E - - HORZ(TL): 0.007 I - - Creep Factor: 2.0 Max TC CSI: 0.183 Max BC CSI: 0.081 Max Web CSI: 0.171 VIEW Ver: 24.02.00D.0611.08	▲ Maximum Reactions (lbs), or *=PLF <table border="1"> <thead> <tr> <th rowspan="2">Loc</th> <th colspan="3">Gravity</th> <th colspan="3">Non-Gravity</th> </tr> <tr> <th>R+</th> <th>/R-</th> <th>/Rh</th> <th>/Rw</th> <th>/U</th> <th>/RL</th> </tr> </thead> <tbody> <tr> <td>A</td> <td>24</td> <td>/-</td> <td>/-</td> <td>/154</td> <td>/136</td> <td>/246</td> </tr> <tr> <td>B*</td> <td>69</td> <td>/-</td> <td>/-</td> <td>/52</td> <td>/8</td> <td>/-</td> </tr> <tr> <td>M</td> <td>24</td> <td>/-</td> <td>/-</td> <td>/18</td> <td>/1</td> <td>/-</td> </tr> </tbody> </table>	Loc	Gravity			Non-Gravity			R+	/R-	/Rh	/Rw	/U	/RL	A	24	/-	/-	/154	/136	/246	B*	69	/-	/-	/52	/8	/-	M	24	/-	/-	/18	/1	/-
				Loc		Gravity			Non-Gravity																													
R+	/R-	/Rh	/Rw		/U	/RL																																
A	24	/-	/-	/154	/136	/246																																
B*	69	/-	/-	/52	/8	/-																																
M	24	/-	/-	/18	/1	/-																																
Wind reactions based on MWFRS A Brg Wid = 5.9 Min Req = 1.5 (Truss) B Brg Wid = 317 Min Req = - M Brg Wid = 5.9 Min Req = 1.5 (Truss) Bearings A, B, & M are a rigid surface. Members not listed have forces less than 375#																																						

Lumber

Top chord: 2x4 SP #2;
 Bot chord: 2x4 SP #2;
 Webs: 2x4 SP #3;

Plating Notes

All plates are 2X4 except as noted.

Purlins

In lieu of structural panels use purlins to brace all flat TC @ 24" oc.

Wind

Wind loads based on MWFRS with additional C&C member design.
 Wind loading based on both gable and hip roof types.

Additional Notes

Refer to DWG PB160220723 for piggyback details.
 The overall height of this truss excluding overhang is 8-0-0.



COA #0278

02/02/2026
 Florida Certificate of Product Approval #FL 1999

****WARNING** READ AND FOLLOW ALL NOTES ON THIS DRAWING!**
****IMPORTANT** FURNISH THIS DRAWING TO ALL CONTRACTORS INCLUDING THE INSTALLERS**
 Trusses require extreme care in fabricating, handling, shipping, installing and bracing. Refer to and follow the latest edition of BCSI (Building Component Safety Information, by TPI and SBCA) for safety practices prior to performing these functions. Installers shall provide temporary bracing per BCSI. Unless noted otherwise, top chord shall have properly attached structural sheathing and bottom chord shall have a properly attached rigid ceiling. Locations shown for permanent lateral restraint of webs shall have continuous lateral restraint (CLR), installed with diagonal bracing installed on the CLR per BCSI sections B3, B7, or B10, as applicable. Apply plates to each face of truss and position as shown above and on the Joint Details, unless noted otherwise. Refer to drawings 160A-Z for standard plate positions. Refer to job's General Notes page for additional information.
 Alpine, a division of ITW Building Components Group Inc. shall not be responsible for any deviation from this drawing, any failure to build the truss in conformance with ANSI/TPI 1, or for handling, shipping, installation and bracing of trusses. A seal on this drawing or cover page listing this drawing, indicates acceptance of professional engineering responsibility solely for the design shown. The suitability and use of this drawing for any structure is the responsibility of the Building Designer per ANSI/TPI 1 Sec.2.
 For more information see these web sites: Alpine: alpineitw.com; TPI: tpinst.org; SBCA: sbcacomponents.com; ICC: iccsafe.org; AWC: awc.org



SEQN: 430554 FROM: CDM	HIPS Ply: 1 Qty: 1	Job Number: 26-3432 MOORE Truss Label: PB04	Cust: R215 JRRef: 1YH82150009 T10 DrwNo: 030.26.1739.22593 GA / WHK 01/30/2026
---------------------------	--------------------------	---	--

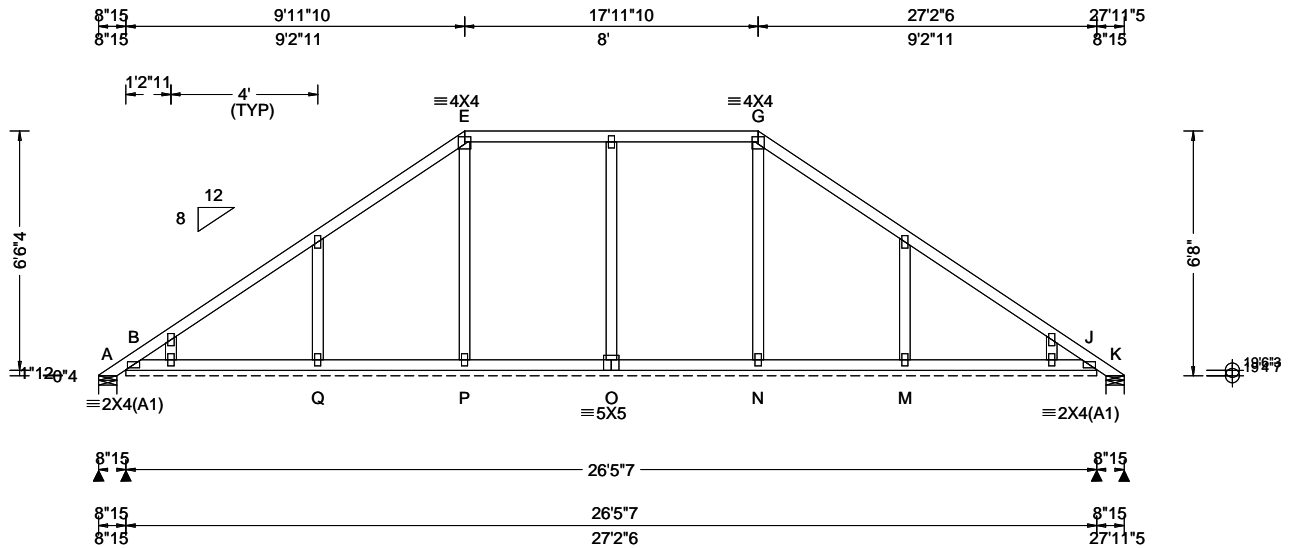

Loading Criteria (psf) TCLL: 20.00 TCCL: 10.00 BCLL: 0.00 BCDL: 10.00 Des Ld: 40.00 NCBCLL: 10.00 Soffit: 2.00 Load Duration: 1.25 Spacing: 24.0 "	Wind Criteria Wind Std: ASCE 7-22 Speed: 130 mph Enclosure: Enclosed Risk Category: II EXP: C Kzt: NA Mean Height: 17.20 ft TCCL: 5.0 psf BCDL: 5.0 psf MWFRS Parallel Dist: h to 2h C&C Dist a: 4.22 ft Loc. from endwall: not in 13.00 ft GCp: 0.18 Wind Duration: 1.60	Snow Criteria (Pg,Pf in PSF) Pg: NA Ct: NA CAT: NA Pf: NA Ce: NA Lu: NA Cs: NA Snow Duration: NA Building Code: FBC 8th Ed. 2023 Res. TPI Std: 2014 Rep Fac: Yes FT/RT:20(0)/10(0) Plate Type(s): WAVE	Defl/CSI Criteria PP Deflection in loc L/defl L/# VERT(LL): 0.003 F 999 240 VERT(CL): 0.003 F 999 180 HORZ(LL): 0.001 J - - HORZ(TL): 0.006 H - - Creep Factor: 2.0 Max TC CSI: 0.239 Max BC CSI: 0.078 Max Web CSI: 0.240 VIEW Ver: 24.02.00D.0611.08	▲ Maximum Reactions (lbs), or *=PLF Gravity Loc R+ / R- / Rh / Rw / U / RL Non-Gravity / Rw / U / RL
				A 24 /- /- /129 /111 /204 B* 69 /- /- /50 /8 /- K 24 /- /- /19 /2 /- Q /-105 M /-105 Wind reactions based on MWFRS A Brg Wid = 5.9 Min Req = 1.5 (Truss) B Brg Wid = 317 Min Req = - K Brg Wid = 5.9 Min Req = 1.5 (Truss) Bearings A, B, & K are a rigid surface. Members not listed have forces less than 375#

Lumber

Top chord: 2x4 SP #2;
 Bot chord: 2x4 SP #2;
 Webs: 2x4 SP #3;

Plating Notes

All plates are 2X4 except as noted.

Purlins

In lieu of structural panels use purlins to brace all flat TC @ 24" oc.

Wind

Wind loads based on MWFRS with additional C&C member design.
 Wind loading based on both gable and hip roof types.

Additional Notes

Refer to DWG PB160220723 for piggyback details.
 The overall height of this truss excluding overhang is 6-8-0.

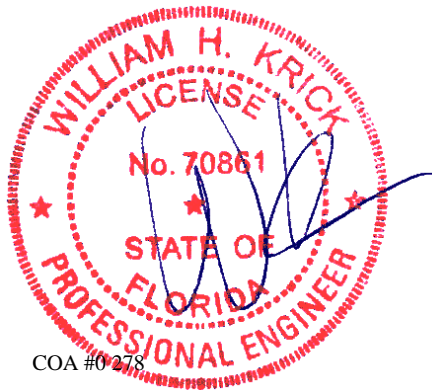

COA #0278

Florida Certificate of Product Approval #FL 1999

****WARNING** READ AND FOLLOW ALL NOTES ON THIS DRAWING!**
****IMPORTANT** FURNISH THIS DRAWING TO ALL CONTRACTORS INCLUDING THE INSTALLERS**
 Trusses require extreme care in fabricating, handling, shipping, installing and bracing. Refer to and follow the latest edition of BCSI (Building Component Safety Information, by TPI and SBCA) for safety practices prior to performing these functions. Installers shall provide temporary bracing per BCSI. Unless noted otherwise, top chord shall have properly attached structural sheathing and bottom chord shall have a properly attached rigid ceiling. Locations shown for permanent lateral restraint of webs shall have continuous lateral restraint (CLR), installed with diagonal bracing installed on the CLR per BCSI sections B3, B7, or B10, as applicable. Apply plates to each face of truss and position as shown above and on the Joint Details, unless noted otherwise. Refer to drawings 160A-Z for standard plate positions. Refer to job's General Notes page for additional information.
 Alpine, a division of ITW Building Components Group Inc. shall not be responsible for any deviation from this drawing, any failure to build the truss in conformance with ANSI/TPI 1, or for handling, shipping, installation and bracing of trusses. A seal on this drawing or cover page listing this drawing, indicates acceptance of professional engineering responsibility solely for the design shown. The suitability and use of this drawing for any structure is the responsibility of the Building Designer per ANSI/TPI 1 Sec.2.
 For more information see these web sites: Alpine: alpineitw.com; TPI: tpinst.org; SBCA: sbcacomponents.com; ICC: iccsafe.org; AWC: awc.org



SEQN: 430584 FROM: CDM	HIPS Ply: 1 Qty: 1	Job Number: 26-3432 MOORE Truss Label: PB05	Cust: R215 JRRef: 1YH82150009 T9 DrwNo: 030.26.1739.25767 GA / WHK 01/30/2026
---------------------------	--------------------------	---	---

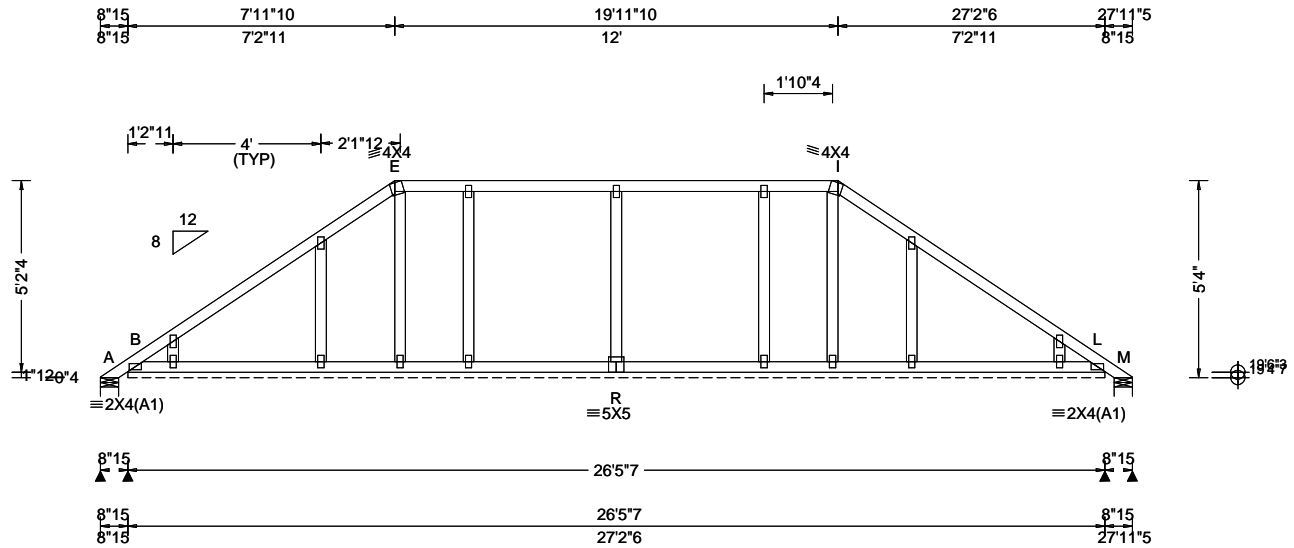

Loading Criteria (psf) TCLL: 20.00 TC DL: 10.00 BCLL: 0.00 BCDL: 10.00 Des Ld: 40.00 NCBCLL: 10.00 Soffit: 2.00 Load Duration: 1.25 Spacing: 24.0 "	Wind Criteria Wind Std: ASCE 7-22 Speed: 130 mph Enclosure: Enclosed Risk Category: II EXP: C Kzt: NA Mean Height: 16.54 ft TC DL: 5.0 psf BCDL: 5.0 psf MWFRS Parallel Dist: h to 2h C&C Dist a: 4.22 ft Loc. from endwall: not in 13.00 ft GCp: 0.18 Wind Duration: 1.60	Snow Criteria (Pg,Pf in PSF) Pg: NA Ct: NA CAT: NA Pf: NA Ce: NA Lu: NA Cs: NA Snow Duration: NA Building Code: FBC 8th Ed. 2023 Res. TPI Std: 2014 Rep Fac: Yes FT/RT:20(0)/10(0) Plate Type(s): WAVE	Defl/CSI Criteria PP Deflection in loc L/defl L/# VERT(LL): 0.001 G 999 240 VERT(CL): 0.002 G 999 180 HORZ(LL): 0.000 D - - HORZ(TL): 0.004 J - - Creep Factor: 2.0 Max TC CSI: 0.183 Max BC CSI: 0.075 Max Web CSI: 0.131 VIEW Ver: 24.02.00D.0611.08	▲ Maximum Reactions (lbs), or *=PLF Gravity Non-Gravity Loc R+ / R- / Rh / Rw / U / RL
				A 24 /- /- /104 /86 /161 B* 69 /- /- /48 /8 /- M 24 /- /- /21 /3 /- Wind reactions based on MWFRS A Brg Wid = 5.9 Min Req = 1.5 (Truss) B Brg Wid = 317 Min Req = - M Brg Wid = 5.9 Min Req = 1.5 (Truss) Bearings A, B, & M are a rigid surface. Members not listed have forces less than 375#

Lumber

Top chord: 2x4 SP #2;
 Bot chord: 2x4 SP #2;
 Webs: 2x4 SP #3;

Plating Notes

All plates are 2X4 except as noted.

Purlins

In lieu of structural panels use purlins to brace all flat TC @ 24" oc.

Wind

Wind loads based on MWFRS with additional C&C member design.
 Wind loading based on both gable and hip roof types.

Additional Notes

Refer to DWG PB160220723 for piggyback details.
 The overall height of this truss excluding overhang is 5-4-0.



COA #0278

Florida Certificate of Product Approval #FL 1999

****WARNING** READ AND FOLLOW ALL NOTES ON THIS DRAWING!**
****IMPORTANT** FURNISH THIS DRAWING TO ALL CONTRACTORS INCLUDING THE INSTALLERS**
 Trusses require extreme care in fabricating, handling, shipping, installing and bracing. Refer to and follow the latest edition of BCSI (Building Component Safety Information, by TPI and SBCA) for safety practices prior to performing these functions. Installers shall provide temporary bracing per BCSI. Unless noted otherwise, top chord shall have properly attached structural sheathing and bottom chord shall have a properly attached rigid ceiling. Locations shown for permanent lateral restraint of webs shall have continuous lateral restraint (CLR), installed with diagonal bracing installed on the CLR per BCSI sections B3, B7, or B10, as applicable. Apply plates to each face of truss and position as shown above and on the Joint Details, unless noted otherwise. Refer to drawings 160A-Z for standard plate positions. Refer to job's General Notes page for additional information.
 Alpine, a division of ITW Building Components Group Inc. shall not be responsible for any deviation from this drawing, any failure to build the truss in conformance with ANSI/TPI 1, or for handling, shipping, installation and bracing of trusses. A seal on this drawing or cover page listing this drawing, indicates acceptance of professional engineering responsibility solely for the design shown. The suitability and use of this drawing for any structure is the responsibility of the Building Designer per ANSI/TPI 1 Sec.2.
 For more information see these web sites: Alpine: alpineitw.com; TPI: tpinst.org; SBCA: sbcacomponents.com; ICC: iccsafe.org; AWC: awc.org



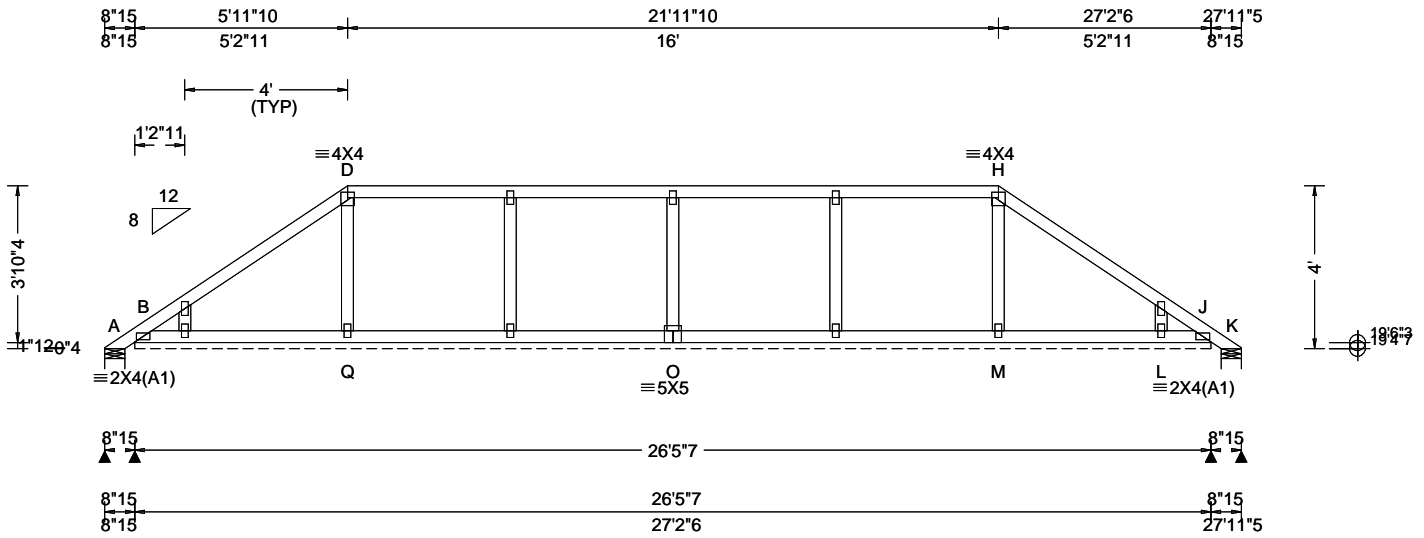

Loading Criteria (psf)	Wind Criteria	Snow Criteria (Pg, Pf in PSF)	Defl/CSI Criteria	▲ Maximum Reactions (lbs), or * = PLF						
				Gravity			Non-Gravity			
TCLL: 20.00	Wind Std: ASCE 7-22	Pg: NA Ct: NA CAT: NA	PP Deflection in loc L/defl L/#	Loc	R+	/R-	/Rh	/Rw	/U	/RL
TCDL: 10.00	Speed: 130 mph	Pf: NA Ce: NA	VERT(LL): 0.001 E 999 240	A	26	/-	/-	/80	/61	/119
BCLL: 0.00	Enclosure: Enclosed	Lu: NA Cs: NA	VERT(CL): 0.002 E 999 180	B*	69	/-	/-	/47	/8	/-
BCDL: 10.00	Risk Category: II	Snow Duration: NA	HORZ(LL): 0.001 J - -	K	26	/-	/-	/23	/5	/-
Des Ld: 40.00	EXP: C Kzt: NA	Building Code:	HORZ(TL): 0.002 I - -	L						
NCBCLL: 10.00	Mean Height: 15.87 ft	FBC 8th Ed. 2023 Res.	Creep Factor: 2.0							
Soffit: 2.00	TCDL: 5.0 psf	TPI Std: 2014	Max TC CSI: 0.209	Wind reactions based on MWFRS						
Load Duration: 1.25	BCDL: 5.0 psf	Rep Fac: Yes	Max BC CSI: 0.076	A Brg Wid = 5.9 Min Req = 1.5 (Truss)						
Spacing: 24.0 "	MWFRS Parallel Dist: h to 2h	FT/RT: 20(0)/10(0)	Max Web CSI: 0.084	B Brg Wid = 317 Min Req = -						
	C&C Dist a: 4.22 ft	Plate Type(s):	VIEW Ver: 24.02.00D.0611.08	K Brg Wid = 5.9 Min Req = 1.5 (Truss)						
	Loc. from endwall: not in 13.00 ft	WAVE		Bearings A, B, & K are a rigid surface.						
	GCpi: 0.18			Members not listed have forces less than 375#						
	Wind Duration: 1.60									

Lumber

Top chord: 2x4 SP #2;
Bot chord: 2x4 SP #2;
Webs: 2x4 SP #3;

Plating Notes

All plates are 2X4 except as noted.

Purlins

In lieu of structural panels use purlins to brace all flat TC @ 24" oc.

Wind

Wind loads based on MWFRS with additional C&C member design.
Wind loading based on both gable and hip roof types.

Additional Notes

Refer to DWG PB160220723 for piggyback details.
The overall height of this truss excluding overhang is 4-0-0.



COA #0278

Florida Certificate of Product Approval #FL 1999

****WARNING** READ AND FOLLOW ALL NOTES ON THIS DRAWING!**
****IMPORTANT** FURNISH THIS DRAWING TO ALL CONTRACTORS INCLUDING THE INSTALLERS**
Trusses require extreme care in fabricating, handling, shipping, installing and bracing. Refer to and follow the latest edition of BCSI (Building Component Safety Information, by TPI and SBCA) for safety practices prior to performing these functions. Installers shall provide temporary bracing per BCSI. Unless noted otherwise, top chord shall have properly attached structural sheathing and bottom chord shall have a properly attached rigid ceiling. Locations shown for permanent lateral restraint of webs shall have continuous lateral restraint (CLR), installed with diagonal bracing installed on the CLR per BCSI sections B3, B7, or B10, as applicable. Apply plates to each face of truss and position as shown above and on the Joint Details, unless noted otherwise. Refer to drawings 160A-Z for standard plate positions. Refer to job's General Notes page for additional information.
Alpine, a division of ITW Building Components Group Inc. shall not be responsible for any deviation from this drawing, any failure to build the truss in conformance with ANSI/TPI 1, or for handling, shipping, installation and bracing of trusses. A seal on this drawing or cover page listing this drawing, indicates acceptance of professional engineering responsibility solely for the design shown. The suitability and use of this drawing for any structure is the responsibility of the Building Designer per ANSI/TPI 1 Sec.2.
For more information see these web sites: Alpine: alpineitw.com; TPI: tpinst.org; SBCA: sbccomponents.com; ICC: iccsafe.org; AWC: awc.org



SEQN: 430580 FROM: CDM	HIPS Ply: 1 Qty: 1	Job Number: 26-3432 MOORE Truss Label: PB07	Cust: R215 JRRef: 1YH82150009 T7 DrwNo: 030.26.1739.31380 GA / WHK 01/30/2026
---------------------------	--------------------------	---	---

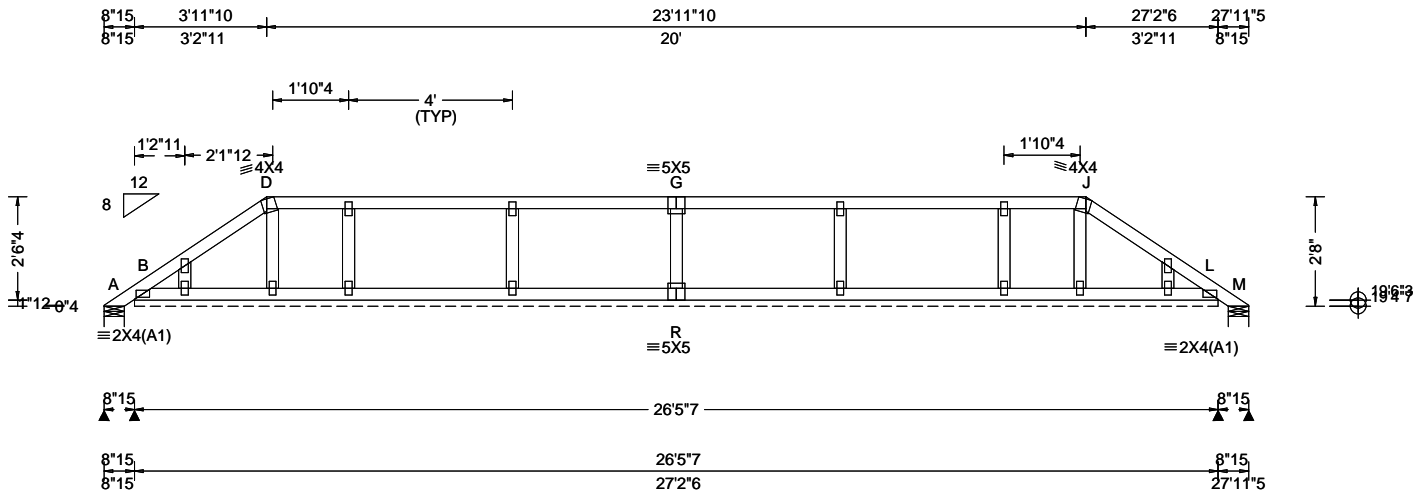

Loading Criteria (psf) TCCL: 20.00 TCCL: 10.00 BCLL: 0.00 BCDL: 10.00 Des Ld: 40.00 NCBCLL: 10.00 Soffit: 2.00 Load Duration: 1.25 Spacing: 24.0 "	Wind Criteria Wind Std: ASCE 7-22 Speed: 130 mph Enclosure: Enclosed Risk Category: II EXP: C Kzt: NA Mean Height: 15.20 ft TCCL: 5.0 psf BCDL: 5.0 psf MWFRS Parallel Dist: h to 2h C&C Dist a: 4.22 ft Loc. from endwall: not in 13.00 ft GCp: 0.18 Wind Duration: 1.60	Snow Criteria (Pg,Pf in PSF) Pg: NA Ct: NA CAT: NA Pf: NA Ce: NA Lu: NA Cs: NA Snow Duration: NA Building Code: FBC 8th Ed. 2023 Res. TPI Std: 2014 Rep Fac: Yes FT/RT:20(0)/10(0) Plate Type(s): WAVE	Defl/CSI Criteria PP Deflection in loc L/defl L/# VERT(LL): 0.001 F 999 240 VERT(CL): 0.001 F 999 180 HORZ(LL): 0.000 L - - HORZ(TL): 0.001 K - - Creep Factor: 2.0 Max TC CSI: 0.178 Max BC CSI: 0.077 Max Web CSI: 0.062 VIEW Ver: 24.02.00D.0611.08	▲ Maximum Reactions (lbs), or *=PLF <table border="1"> <thead> <tr> <th rowspan="2">Loc</th> <th colspan="3">Gravity</th> <th colspan="3">Non-Gravity</th> </tr> <tr> <th>R+</th> <th>/R-</th> <th>/Rh</th> <th>/Rw</th> <th>/U</th> <th>/RL</th> </tr> </thead> <tbody> <tr> <td>A</td> <td>20</td> <td>/-</td> <td>/-</td> <td>/54</td> <td>/39</td> <td>/77</td> </tr> <tr> <td>B*</td> <td>69</td> <td>/-</td> <td>/-</td> <td>/45</td> <td>/8</td> <td>/-</td> </tr> <tr> <td>M</td> <td>20</td> <td>/-</td> <td>/-</td> <td>/19</td> <td>/4</td> <td>/-</td> </tr> </tbody> </table> <p>Wind reactions based on MWFRS A Brg Wid = 5.9 Min Req = 1.5 (Truss) B Brg Wid = 317 Min Req = - M Brg Wid = 5.9 Min Req = 1.5 (Truss) Bearings A, B, & M are a rigid surface. Members not listed have forces less than 375#</p>	Loc	Gravity			Non-Gravity			R+	/R-	/Rh	/Rw	/U	/RL	A	20	/-	/-	/54	/39	/77	B*	69	/-	/-	/45	/8	/-	M	20	/-	/-	/19	/4	/-
Loc	Gravity			Non-Gravity																																		
	R+	/R-	/Rh	/Rw	/U	/RL																																
A	20	/-	/-	/54	/39	/77																																
B*	69	/-	/-	/45	/8	/-																																
M	20	/-	/-	/19	/4	/-																																

Lumber

Top chord: 2x4 SP #2;
 Bot chord: 2x4 SP #2;
 Webs: 2x4 SP #3;

Plating Notes

All plates are 2X4 except as noted.

Purlins

In lieu of structural panels use purlins to brace all flat TC @ 24" oc.

Wind

Wind loads based on MWFRS with additional C&C member design.
 Wind loading based on both gable and hip roof types.

Additional Notes

Refer to DWG PB160220723 for piggyback details.
 The overall height of this truss excluding overhang is 2-8-0.



COA #0278

02/02/2026
 Florida Certificate of Product Approval #FL 1999

****WARNING** READ AND FOLLOW ALL NOTES ON THIS DRAWING!**
****IMPORTANT** FURNISH THIS DRAWING TO ALL CONTRACTORS INCLUDING THE INSTALLERS**
 Trusses require extreme care in fabricating, handling, shipping, installing and bracing. Refer to and follow the latest edition of BCSI (Building Component Safety Information, by TPI and SBCA) for safety practices prior to performing these functions. Installers shall provide temporary bracing per BCSI. Unless noted otherwise, top chord shall have properly attached structural sheathing and bottom chord shall have a properly attached rigid ceiling. Locations shown for permanent lateral restraint of webs shall have continuous lateral restraint (CLR), installed with diagonal bracing installed on the CLR per BCSI sections B3, B7, or B10, as applicable. Apply plates to each face of truss and position as shown above and on the Joint Details, unless noted otherwise. Refer to drawings 160A-Z for standard plate positions. Refer to job's General Notes page for additional information.
 Alpine, a division of ITW Building Components Group Inc. shall not be responsible for any deviation from this drawing, any failure to build the truss in conformance with ANSI/TPI 1, or for handling, shipping, installation and bracing of trusses. A seal on this drawing or cover page listing this drawing, indicates acceptance of professional engineering responsibility solely for the design shown. The suitability and use of this drawing for any structure is the responsibility of the Building Designer per ANSI/TPI 1 Sec.2.
 For more information see these web sites: Alpine: alpineitw.com; TPI: tpinst.org; SBCA: sbccomponents.com; ICC: iccsafe.org; AWC: awc.org



SEQN: 430578 FROM: CDM	HIPS Ply: 1 Qty: 1	Job Number: 26-3432 MOORE Truss Label: PB08	Cust: R215 JRRef: 1YH82150009 T6 DrwNo: 030.26.1739.33150 GA / WHK 01/30/2026
---------------------------	--------------------------	---	---

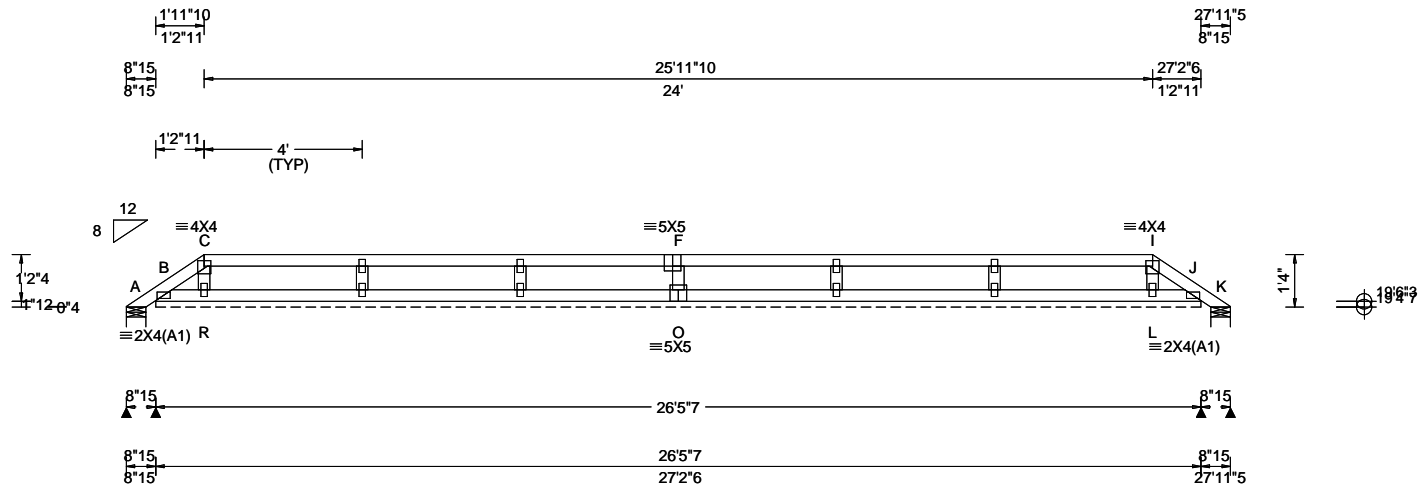

Loading Criteria (psf) TCCL: 20.00 TCDL: 10.00 BCLL: 0.00 BCDL: 10.00 Des Ld: 40.00 NCBCLL: 10.00 Soffit: 2.00 Load Duration: 1.25 Spacing: 24.0 "	Wind Criteria Wind Std: ASCE 7-22 Speed: 130 mph Enclosure: Enclosed Risk Category: II EXP: C Kzt: NA Mean Height: 15.00 ft TCDL: 5.0 psf BCDL: 5.0 psf MWFRS Parallel Dist: h to 2h C&C Dist a: 4.22 ft Loc. from endwall: not in 13.00 ft GCpi: 0.18 Wind Duration: 1.60	Snow Criteria (Pg,Pf in PSF) Pg: NA Ct: NA CAT: NA Pf: NA Ce: NA Lu: NA Cs: NA Snow Duration: NA Building Code: FBC 8th Ed. 2023 Res. TPI Std: 2014 Rep Fac: Yes FT/RT:20(0)/10(0) Plate Type(s): WAVE	Defl/CSI Criteria PP Deflection in loc L/defl L/# VERT(LL): 0.000 H 999 240 VERT(CL): 0.000 H 999 180 HORZ(LL): 0.000 J - - HORZ(TL): 0.001 J - - Creep Factor: 2.0 Max TC CSI: 0.205 Max BC CSI: 0.075 Max Web CSI: 0.052 VIEW Ver: 24.02.00D.0611.08	▲ Maximum Reactions (lbs), or *=PLF <table border="1"> <thead> <tr> <th rowspan="2">Loc</th> <th colspan="3">Gravity</th> <th colspan="3">Non-Gravity</th> </tr> <tr> <th>R+</th> <th>/R-</th> <th>/Rh</th> <th>/Rw</th> <th>/U</th> <th>/RL</th> </tr> </thead> <tbody> <tr> <td>A</td> <td>17</td> <td>/-</td> <td>/-</td> <td>/30</td> <td>/15</td> <td>/36</td> </tr> <tr> <td>B*</td> <td>69</td> <td>/-</td> <td>/-</td> <td>/43</td> <td>/9</td> <td>/-</td> </tr> <tr> <td>K</td> <td>17</td> <td>/-</td> <td>/-</td> <td>/18</td> <td>/3</td> <td>/-</td> </tr> </tbody> </table> Wind reactions based on MWFRS A Brg Wid = 5.9 Min Req = 1.5 (Truss) B Brg Wid = 317 Min Req = - K Brg Wid = 5.9 Min Req = 1.5 (Truss) Bearings A, B, & K are a rigid surface. Members not listed have forces less than 375#	Loc	Gravity			Non-Gravity			R+	/R-	/Rh	/Rw	/U	/RL	A	17	/-	/-	/30	/15	/36	B*	69	/-	/-	/43	/9	/-	K	17	/-	/-	/18	/3	/-
Loc	Gravity			Non-Gravity																																		
	R+	/R-	/Rh	/Rw	/U	/RL																																
A	17	/-	/-	/30	/15	/36																																
B*	69	/-	/-	/43	/9	/-																																
K	17	/-	/-	/18	/3	/-																																

Lumber

Top chord: 2x4 SP #2;
 Bot chord: 2x4 SP #2;
 Webs: 2x4 SP #3;

Plating Notes

All plates are 2X4 except as noted.

Purlins

In lieu of structural panels use purlins to brace all flat TC @ 24" oc.

Wind

Wind loads based on MWFRS with additional C&C member design.
 Wind loading based on both gable and hip roof types.

Additional Notes

Refer to DWG PB160220723 for piggyback details.
 The overall height of this truss excluding overhang is 1-4-0.

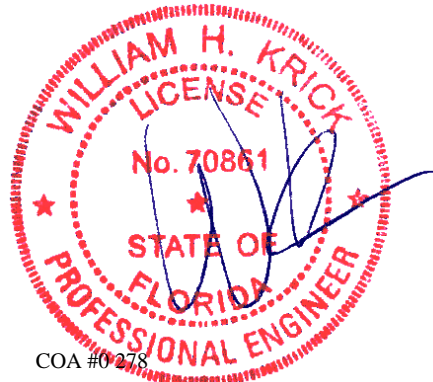

COA #0278

02/02/2026 Florida Certificate of Product Approval #FL 1999

****WARNING** READ AND FOLLOW ALL NOTES ON THIS DRAWING!**
****IMPORTANT** FURNISH THIS DRAWING TO ALL CONTRACTORS INCLUDING THE INSTALLERS**
 Trusses require extreme care in fabricating, handling, shipping, installing and bracing. Refer to and follow the latest edition of BCSI (Building Component Safety Information, by TPI and SBCA) for safety practices prior to performing these functions. Installers shall provide temporary bracing per BCSI. Unless noted otherwise, top chord shall have properly attached structural sheathing and bottom chord shall have a properly attached rigid ceiling. Locations shown for permanent lateral restraint of webs shall have continuous lateral restraint (CLR), installed with diagonal bracing installed on the CLR per BCSI sections B3, B7, or B10, as applicable. Apply plates to each face of truss and position as shown above and on the Joint Details, unless noted otherwise. Refer to drawings 160A-Z for standard plate positions. Refer to job's General Notes page for additional information.
 Alpine, a division of ITW Building Components Group Inc. shall not be responsible for any deviation from this drawing, any failure to build the truss in conformance with ANSI/TPI 1, or for handling, shipping, installation and bracing of trusses. A seal on this drawing or cover page listing this drawing, indicates acceptance of professional engineering responsibility solely for the design shown. The suitability and use of this drawing for any structure is the responsibility of the Building Designer per ANSI/TPI 1 Sec.2.
 For more information see these web sites: Alpine: alpineitw.com; TPI: tpinst.org; SBCA: sbccomponents.com; ICC: iccsafe.org; AWC: awc.org



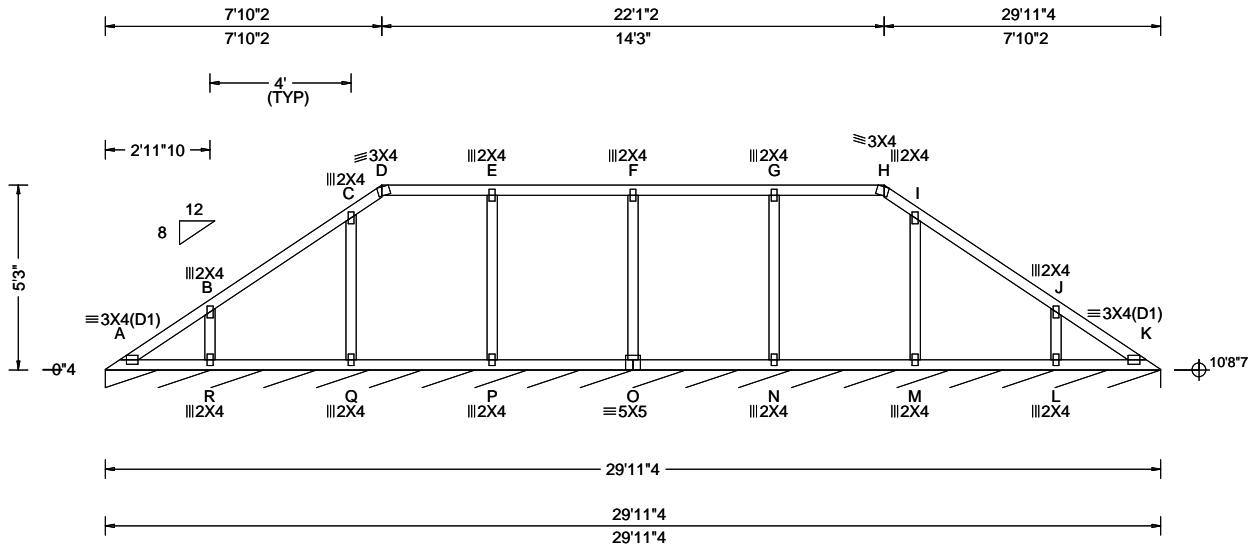

Loading Criteria (psf) TCCL: 20.00 TCDL: 10.00 BCLL: 0.00 BCDL: 10.00 Des Ld: 40.00 NCBCLL: 10.00 Soffit: 2.00 Load Duration: 1.25 Spacing: 24.0 "	Wind Criteria Wind Std: ASCE 7-22 Speed: 130 mph Enclosure: Enclosed Risk Category: II EXP: C Kzt: NA Mean Height: 15.00 ft TCDL: 5.0 psf BCDL: 5.0 psf MWFRS Parallel Dist: h/2 to h C&C Dist a: 3.00 ft Loc. from endwall: not in 9.00 ft GCpi: 0.18 Wind Duration: 1.60	Snow Criteria (Pg,Pf in PSF) Pg: NA Ct: NA CAT: NA Pf: NA Ce: NA Lu: NA Cs: NA Snow Duration: NA Building Code: FBC 8th Ed. 2023 Res. TPI Std: 2014 Rep Fac: Yes FT/RT:20(0)/10(0) Plate Type(s): WAVE	Defl/CSI Criteria PP Deflection in loc L/defl L/# VERT(LL): 0.003 D 999 240 VERT(CL): 0.006 D 999 180 HORZ(LL): -0.001 B - - HORZ(TL): 0.004 C - - Creep Factor: 2.0 Max TC CSI: 0.181 Max BC CSI: 0.113 Max Web CSI: 0.127 VIEW Ver: 24.02.00D.0611.08	▲ Maximum Reactions (lbs), or *=PLF <table border="1"> <thead> <tr> <th colspan="3">Gravity</th> <th colspan="3">Non-Gravity</th> </tr> <tr> <th>Loc</th> <th>R+</th> <th>/R-</th> <th>/Rh</th> <th>/Rw</th> <th>/U</th> <th>/RL</th> </tr> </thead> <tbody> <tr> <td>K*</td> <td>84</td> <td>/-</td> <td>/-</td> <td>/43</td> <td>/14</td> <td>/5</td> </tr> </tbody> </table> Wind reactions based on MWFRS K Brg Wid = 359 Min Req = - Bearing A is a rigid surface. Members not listed have forces less than 375#	Gravity			Non-Gravity			Loc	R+	/R-	/Rh	/Rw	/U	/RL	K*	84	/-	/-	/43	/14	/5
Gravity			Non-Gravity																					
Loc	R+	/R-	/Rh	/Rw	/U	/RL																		
K*	84	/-	/-	/43	/14	/5																		

Lumber

Top chord: 2x4 SP #2;
 Bot chord: 2x4 SP #2;
 Webs: 2x4 SP #3;

Purlins

In lieu of structural panels use purlins to brace all flat TC @ 24" oc.

Wind

Wind loads based on MWFRS with additional C&C member design.
 Wind loading based on both gable and hip roof types.

Additional Notes

See DWGS VALTN220723 and VAL180220723 for valley details.
 The overall height of this truss excluding overhang is 5-3-0.

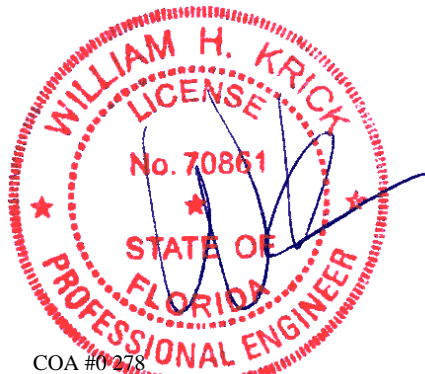

COA #0278

02/02/2026 Florida Certificate of Product Approval #FL 1999

****WARNING** READ AND FOLLOW ALL NOTES ON THIS DRAWING!**
****IMPORTANT** FURNISH THIS DRAWING TO ALL CONTRACTORS INCLUDING THE INSTALLERS**
 Trusses require extreme care in fabricating, handling, shipping, installing and bracing. Refer to and follow the latest edition of BCSI (Building Component Safety Information, by TPI and SBCA) for safety practices prior to performing these functions. Installers shall provide temporary bracing per BCSI. Unless noted otherwise, top chord shall have properly attached structural sheathing and bottom chord shall have a properly attached rigid ceiling. Locations shown for permanent lateral restraint of webs shall have continuous lateral restraint (CLR), installed with diagonal bracing installed on the CLR per BCSI sections B3, B7, or B10, as applicable. Apply plates to each face of truss and position as shown above and on the Joint Details, unless noted otherwise. Refer to drawings 160A-Z for standard plate positions. Refer to job's General Notes page for additional information.
 Alpine, a division of ITW Building Components Group Inc. shall not be responsible for any deviation from this drawing, any failure to build the truss in conformance with ANSI/TPI 1, or for handling, shipping, installation and bracing of trusses. A seal on this drawing or cover page listing this drawing, indicates acceptance of professional engineering responsibility solely for the design shown. The suitability and use of this drawing for any structure is the responsibility of the Building Designer per ANSI/TPI 1 Sec.2.
 For more information see these web sites: Alpine: alpineitw.com; TPI: tpinst.org; SBCA: sbccomponents.com; ICC: iccsafe.org; AWC: awc.org



SEQN: 430503 FROM: RFG	VAL Ply: 1 Qty: 1	Job Number: 26-3432 MOORE Truss Label: V02	Cust: R215 JRef: 1YH82150009 T25 DrwNo: 030.26.1739.37113 GA / WHK 01/30/2026
---------------------------	-------------------------	--	---

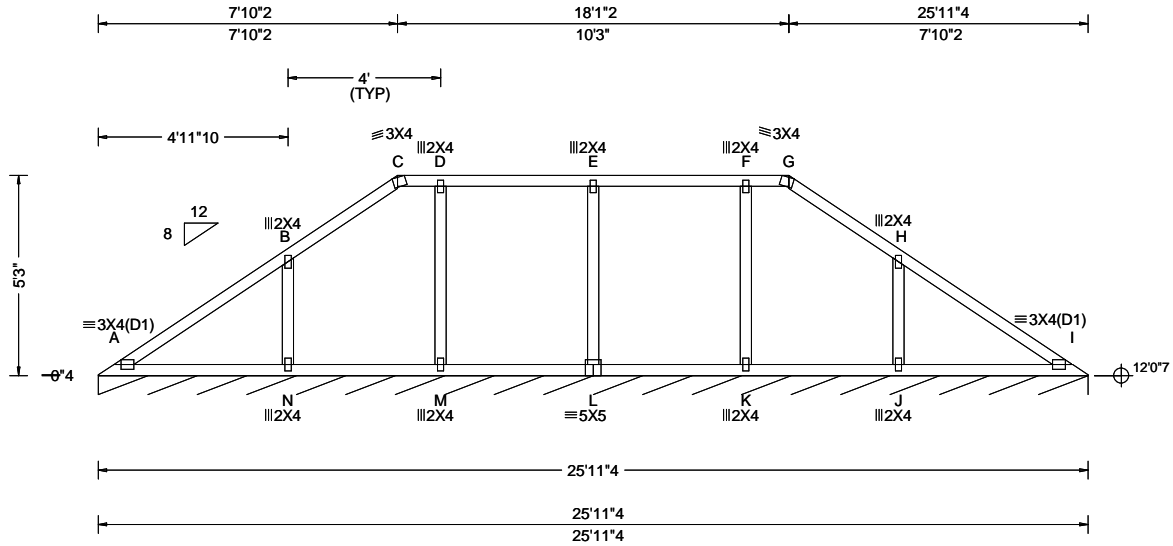

Loading Criteria (psf) TCLL: 20.00 TCDL: 10.00 BCLL: 0.00 BCDL: 10.00 Des Ld: 40.00 NCBCLL: 10.00 Soffit: 2.00 Load Duration: 1.25 Spacing: 24.0 "	Wind Criteria Wind Std: ASCE 7-22 Speed: 130 mph Enclosure: Enclosed Risk Category: II EXP: C Kzt: NA Mean Height: 15.00 ft TCDL: 5.0 psf BCDL: 5.0 psf MWFRS Parallel Dist: h/2 to h C&C Dist a: 3.00 ft Loc. from endwall: not in 9.00 ft GCpi: 0.18 Wind Duration: 1.60	Snow Criteria (Pg,Pf in PSF) Pg: NA Ct: NA CAT: NA Pf: NA Ce: NA Lu: NA Cs: NA Snow Duration: NA Building Code: FBC 8th Ed. 2023 Res. TPI Std: 2014 Rep Fac: Yes FT/RT:20(0)/10(0) Plate Type(s): WAVE	Defl/CSI Criteria PP Deflection in loc L/defl L/# VERT(LL): 0.011 A 999 240 VERT(CL): 0.024 A 999 180 HORZ(LL): 0.004 A - - HORZ(TL): 0.008 A - - Creep Factor: 2.0 Max TC CSI: 0.288 Max BC CSI: 0.205 Max Web CSI: 0.127 VIEW Ver: 24.02.00D.0611.08	▲ Maximum Reactions (lbs), or *=PLF Gravity Non-Gravity Loc R+ / R- / Rh / Rw / U / RL I* 84 /- /- /43 /13 /5 Wind reactions based on MWFRS I Brg Wid = 311 Min Req = - Bearing A is a rigid surface. Members not listed have forces less than 375#
--	--	--	---	---

Lumber

Top chord: 2x4 SP #2;
Bot chord: 2x4 SP #2;
Webs: 2x4 SP #3;

Purlins

In lieu of structural panels use purlins to brace all flat TC @ 24" oc.

Wind

Wind loads based on MWFRS with additional C&C member design.
Wind loading based on both gable and hip roof types.

Additional Notes

See DWGS VALTN220723 and VAL180220723 for valley details.
The overall height of this truss excluding overhang is 5-3-0.

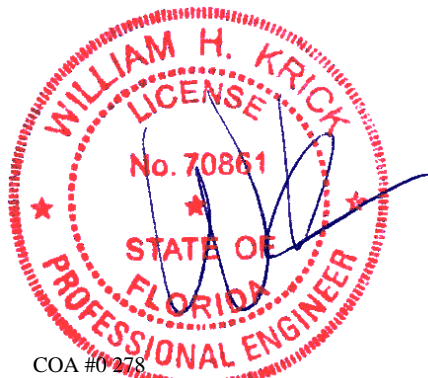

COA #0278

02/02/2026 Florida Certificate of Product Approval #FL 1999

****WARNING** READ AND FOLLOW ALL NOTES ON THIS DRAWING!**
****IMPORTANT** FURNISH THIS DRAWING TO ALL CONTRACTORS INCLUDING THE INSTALLERS**
Trusses require extreme care in fabricating, handling, shipping, installing and bracing. Refer to and follow the latest edition of BCSI (Building Component Safety Information, by TPI and SBCA) for safety practices prior to performing these functions. Installers shall provide temporary bracing per BCSI. Unless noted otherwise, top chord shall have properly attached structural sheathing and bottom chord shall have a properly attached rigid ceiling. Locations shown for permanent lateral restraint of webs shall have continuous lateral restraint (CLR), installed with diagonal bracing installed on the CLR per BCSI sections B3, B7, or B10, as applicable. Apply plates to each face of truss and position as shown above and on the Joint Details, unless noted otherwise. Refer to drawings 160A-Z for standard plate positions. Refer to job's General Notes page for additional information.
Alpine, a division of ITW Building Components Group Inc. shall not be responsible for any deviation from this drawing, any failure to build the truss in conformance with ANSI/TPI 1, or for handling, shipping, installation and bracing of trusses. A seal on this drawing or cover page listing this drawing, indicates acceptance of professional engineering responsibility solely for the design shown. The suitability and use of this drawing for any structure is the responsibility of the Building Designer per ANSI/TPI 1 Sec.2.
For more information see these web sites: Alpine: alpineitw.com; TPI: tpinst.org; SBCA: sbccomponents.com; ICC: iccsafe.org; AWC: awc.org



SEQN: 430485 FROM: RFG	VAL Ply: 1 Qty: 1	Job Number: 26-3432 MOORE Truss Label: V03	Cust: R215 JRef: 1YH82150009 T26 DrwNo: 030.26.1739.38800 GA / WHK 01/30/2026
---------------------------	-------------------------	--	---

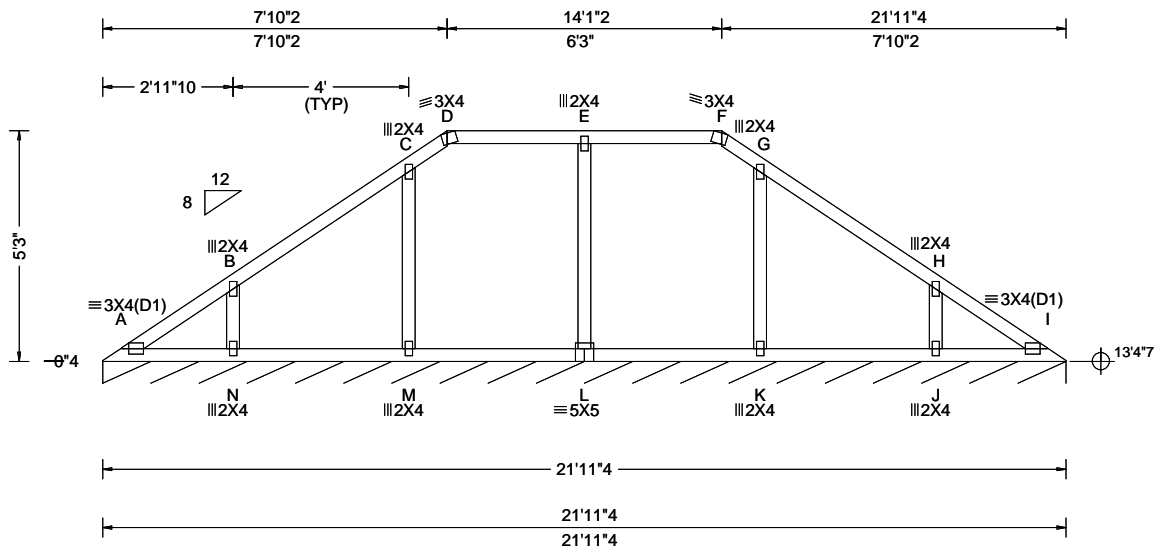

Loading Criteria (psf) TCLL: 20.00 TCDL: 10.00 BCLL: 0.00 BCDL: 10.00 Des Ld: 40.00 NCBCLL: 10.00 Soffit: 2.00 Load Duration: 1.25 Spacing: 24.0 "	Wind Criteria Wind Std: ASCE 7-22 Speed: 130 mph Enclosure: Enclosed Risk Category: II EXP: C Kzt: NA Mean Height: 16.15 ft TCDL: 5.0 psf BCDL: 5.0 psf MWFRS Parallel Dist: h/2 to h C&C Dist a: 3.00 ft Loc. from endwall: not in 9.00 ft GCpi: 0.18 Wind Duration: 1.60	Snow Criteria (Pg,Pf in PSF) Pg: NA Ct: NA CAT: NA Pf: NA Ce: NA Lu: NA Cs: NA Snow Duration: NA Building Code: FBC 8th Ed. 2023 Res. TPI Std: 2014 Rep Fac: Yes FT/RT:20(0)/10(0) Plate Type(s): WAVE	Defl/CSI Criteria PP Deflection in loc L/defl L/# VERT(LL): 0.003 F 999 240 VERT(CL): 0.006 F 999 180 HORZ(LL): -0.001 B - - HORZ(TL): 0.003 C - - Creep Factor: 2.0 Max TC CSI: 0.182 Max BC CSI: 0.113 Max Web CSI: 0.119 VIEW Ver: 24.02.00D.0611.08	▲ Maximum Reactions (lbs), or *=PLF Gravity Non-Gravity Loc R+ / R- / Rh / Rw / U / RL I* 84 /- /- /43 /13 /6 Wind reactions based on MWFRS I Brg Wid = 263 Min Req = - Bearing A is a rigid surface. Members not listed have forces less than 375#
--	--	--	--	---

Lumber

Top chord: 2x4 SP #2;
Bot chord: 2x4 SP #2;
Webs: 2x4 SP #3;

Purlins

In lieu of structural panels use purlins to brace all flat TC @ 24" oc.

Wind

Wind loads based on MWFRS with additional C&C member design.
Wind loading based on both gable and hip roof types.

Additional Notes

See DWGS VALTN220723 and VAL180220723 for valley details.
The overall height of this truss excluding overhang is 5-3-0.

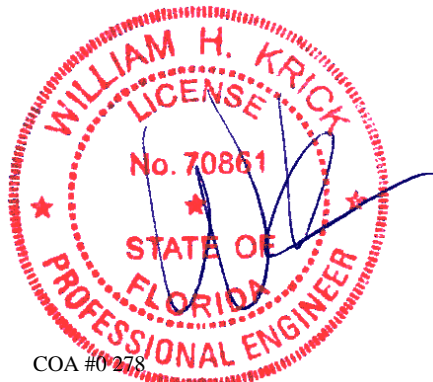

COA #0 278
02/02/2026
Florida Certificate of Product Approval #FL 1999

****WARNING** READ AND FOLLOW ALL NOTES ON THIS DRAWING!**
****IMPORTANT** FURNISH THIS DRAWING TO ALL CONTRACTORS INCLUDING THE INSTALLERS**
Trusses require extreme care in fabricating, handling, shipping, installing and bracing. Refer to and follow the latest edition of BCSI (Building Component Safety Information, by TPI and SBCA) for safety practices prior to performing these functions. Installers shall provide temporary bracing per BCSI. Unless noted otherwise, top chord shall have properly attached structural sheathing and bottom chord shall have a properly attached rigid ceiling. Locations shown for permanent lateral restraint of webs shall have continuous lateral restraint (CLR), installed with diagonal bracing installed on the CLR per BCSI sections B3, B7, or B10, as applicable. Apply plates to each face of truss and position as shown above and on the Joint Details, unless noted otherwise. Refer to drawings 160A-Z for standard plate positions. Refer to job's General Notes page for additional information.
Alpine, a division of ITW Building Components Group Inc. shall not be responsible for any deviation from this drawing, any failure to build the truss in conformance with ANSI/TPI 1, or for handling, shipping, installation and bracing of trusses. A seal on this drawing or cover page listing this drawing, indicates acceptance of professional engineering responsibility solely for the design shown. The suitability and use of this drawing for any structure is the responsibility of the Building Designer per ANSI/TPI 1 Sec.2.
For more information see these web sites: Alpine: alpineitw.com; TPI: tpinst.org; SBCA: sbccomponents.com; ICC: iccsafe.org; AWC: awc.org



SEQN: 430515 FROM: RFG	VAL Ply: 1 Qty: 1	Job Number: 26-3432 MOORE Truss Label: V04	Cust: R215 JRef: 1YH82150009 T27 DrwNo: 030.26.1739.40620 GA / WHK 01/30/2026
---------------------------	-------------------------	--	---

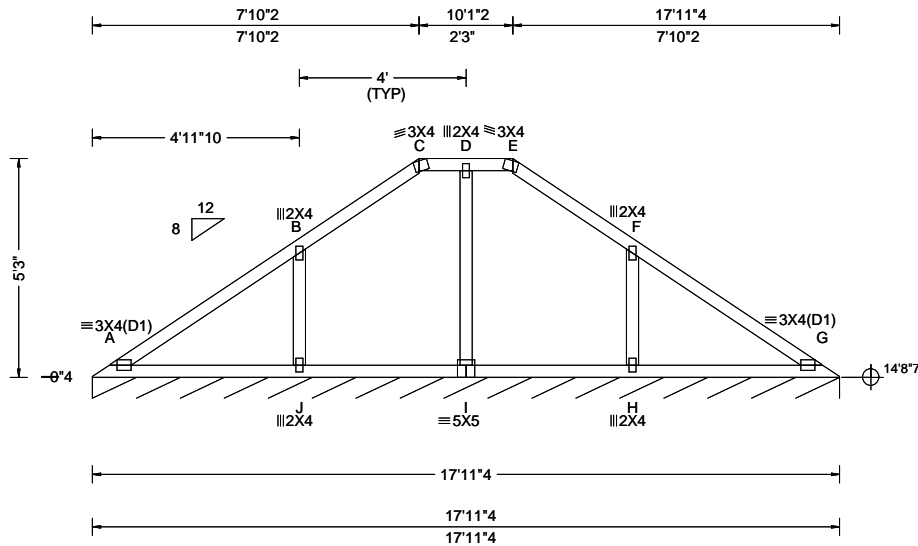

Loading Criteria (psf) TCLL: 20.00 TCDL: 10.00 BCLL: 0.00 BCDL: 10.00 Des Ld: 40.00 NCBCLL: 10.00 Soffit: 2.00 Load Duration: 1.25 Spacing: 24.0 "	Wind Criteria Wind Std: ASCE 7-22 Speed: 130 mph Enclosure: Enclosed Risk Category: II EXP: C Kzt: NA Mean Height: 17.48 ft TCDL: 5.0 psf BCDL: 5.0 psf MWFRS Parallel Dist: h/2 to h C&C Dist a: 3.00 ft Loc. from endwall: not in 9.00 ft GCp: 0.18 Wind Duration: 1.60	Snow Criteria (Pg,Pf in PSF) Pg: NA Ct: NA CAT: NA Pf: NA Ce: NA Lu: NA Cs: NA Snow Duration: NA Building Code: FBC 8th Ed. 2023 Res. TPI Std: 2014 Rep Fac: Yes FT/RT:20(0)/10(0) Plate Type(s): WAVE	Defl/CSI Criteria PP Deflection in loc L/defl L/# VERT(LL): 0.011 A 999 240 VERT(CL): 0.024 A 999 180 HORZ(LL): -0.004 G - - HORZ(TL): 0.008 G - - Creep Factor: 2.0 Max TC CSI: 0.288 Max BC CSI: 0.210 Max Web CSI: 0.111 VIEW Ver: 24.02.00D.0611.08	▲ Maximum Reactions (lbs), or *=PLF Gravity Non-Gravity Loc R+ /R- /Rh /Rw /U /RL G* 84 /- /- /44 /12 /8 Wind reactions based on MWFRS G Brg Wid = 215 Min Req = - Bearing A is a rigid surface. Members not listed have forces less than 375#
--	---	--	--	--

Lumber

Top chord: 2x4 SP #2;
Bot chord: 2x4 SP #2;
Webs: 2x4 SP #3;

Purlins

In lieu of structural panels use purlins to brace all flat TC @ 24" oc.

Wind

Wind loads based on MWFRS with additional C&C member design.
Wind loading based on both gable and hip roof types.

Additional Notes

See DWGS VALTN220723 and VAL180220723 for valley details.
The overall height of this truss excluding overhang is 5-3-0.

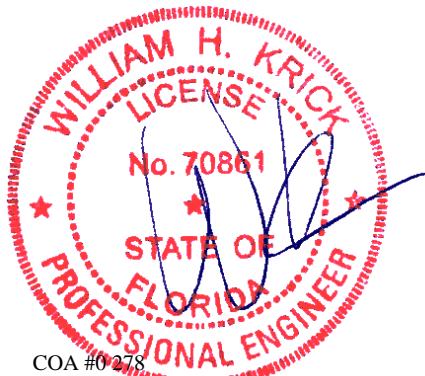

COA #0278

Florida Certificate of Product Approval #FL 1999

****WARNING** READ AND FOLLOW ALL NOTES ON THIS DRAWING!**
****IMPORTANT** FURNISH THIS DRAWING TO ALL CONTRACTORS INCLUDING THE INSTALLERS**
Trusses require extreme care in fabricating, handling, shipping, installing and bracing. Refer to and follow the latest edition of BCSI (Building Component Safety Information, by TPI and SBCA) for safety practices prior to performing these functions. Installers shall provide temporary bracing per BCSI. Unless noted otherwise, top chord shall have properly attached structural sheathing and bottom chord shall have a properly attached rigid ceiling. Locations shown for permanent lateral restraint of webs shall have continuous lateral restraint (CLR), installed with diagonal bracing installed on the CLR per BCSI sections B3, B7, or B10, as applicable. Apply plates to each face of truss and position as shown above and on the Joint Details, unless noted otherwise. Refer to drawings 160A-Z for standard plate positions. Refer to job's General Notes page for additional information.
Alpine, a division of ITW Building Components Group Inc. shall not be responsible for any deviation from this drawing, any failure to build the truss in conformance with ANSI/TPI 1, or for handling, shipping, installation and bracing of trusses. A seal on this drawing or cover page listing this drawing, indicates acceptance of professional engineering responsibility solely for the design shown. The suitability and use of this drawing for any structure is the responsibility of the Building Designer per ANSI/TPI 1 Sec.2.
For more information see these web sites: Alpine: alpineitw.com; TPI: tpinst.org; SBCA: sbccomponents.com; ICC: iccsafe.org; AWC: awc.org



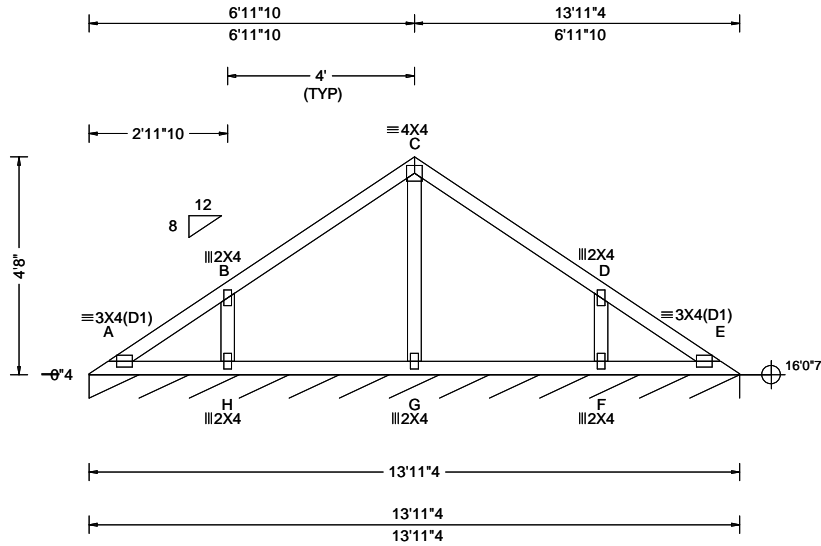

Loading Criteria (psf)	Wind Criteria	Snow Criteria (Pg,Pf in PSF)	Defl/CSI Criteria	▲ Maximum Reactions (lbs), or *=PLF
TCLL: 20.00 TCDL: 10.00 BCLL: 0.00 BCDL: 10.00 Des Ld: 40.00 NCBCLL: 10.00 Soffit: 2.00 Load Duration: 1.25 Spacing: 24.0 "	Wind Std: ASCE 7-22 Speed: 130 mph Enclosure: Enclosed Risk Category: II EXP: C Kzt: NA Mean Height: 18.53 ft TCDL: 5.0 psf BCDL: 5.0 psf MWFRS Parallel Dist: h to 2h C&C Dist a: 3.00 ft Loc. from endwall: not in 9.00 ft GCpi: 0.18 Wind Duration: 1.60	Pg: NA Ct: NA CAT: NA Pf: NA Ce: NA Lu: NA Cs: NA Snow Duration: NA Building Code: FBC 8th Ed. 2023 Res. TPI Std: 2014 Rep Fac: Yes FT/RT:20(0)/10(0) Plate Type(s): WAVE	PP Deflection in loc L/defl L/# VERT(LL): 0.001 A 999 240 VERT(CL): 0.002 A 999 180 HORZ(LL): -0.001 E - - HORZ(TL): 0.001 B - - Creep Factor: 2.0 Max TC CSI: 0.248 Max BC CSI: 0.110 Max Web CSI: 0.077 VIEW Ver: 24.02.00D.0611.08	Gravity Loc R+ / R- / Rh / Rw / U / RL E* 84 /- /- /44 /2 /9 Non-Gravity Wind reactions based on MWFRS E Brg Wid = 167 Min Req = - Bearing A is a rigid surface. Members not listed have forces less than 375#

Lumber

Top chord: 2x4 SP #2;
Bot chord: 2x4 SP #2;
Webs: 2x4 SP #3;

Wind

Wind loads based on MWFRS with additional C&C member design.
Wind loading based on both gable and hip roof types.

Additional Notes

See DWGS VALTN220723 and VAL180220723 for valley details.
The overall height of this truss excluding overhang is 4-8-0.

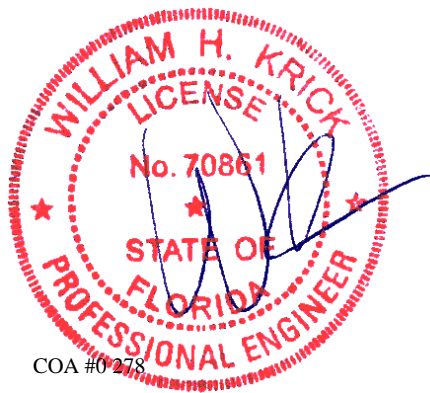

COA #0278

01/02/2026
Florida Certificate of Product Approval #FL 1999

****WARNING** READ AND FOLLOW ALL NOTES ON THIS DRAWING!**
****IMPORTANT** FURNISH THIS DRAWING TO ALL CONTRACTORS INCLUDING THE INSTALLERS**
Trusses require extreme care in fabricating, handling, shipping, installing and bracing. Refer to and follow the latest edition of BCSI (Building Component Safety Information, by TPI and SBCA) for safety practices prior to performing these functions. Installers shall provide temporary bracing per BCSI. Unless noted otherwise, top chord shall have properly attached structural sheathing and bottom chord shall have a properly attached rigid ceiling. Locations shown for permanent lateral restraint of webs shall have continuous lateral restraint (CLR), installed with diagonal bracing installed on the CLR per BCSI sections B3, B7, or B10, as applicable. Apply plates to each face of truss and position as shown above and on the Joint Details, unless noted otherwise. Refer to drawings 160A-Z for standard plate positions. Refer to job's General Notes page for additional information.
Alpine, a division of ITW Building Components Group Inc. shall not be responsible for any deviation from this drawing, any failure to build the truss in conformance with ANSI/TPI 1, or for handling, shipping, installation and bracing of trusses. A seal on this drawing or cover page listing this drawing, indicates acceptance of professional engineering responsibility solely for the design shown. The suitability and use of this drawing for any structure is the responsibility of the Building Designer per ANSI/TPI 1 Sec.2.
For more information see these web sites: Alpine: alpineitw.com; TPI: tpinst.org; SBCA: sbccomponents.com; ICC: iccsafe.org; AWC: awc.org



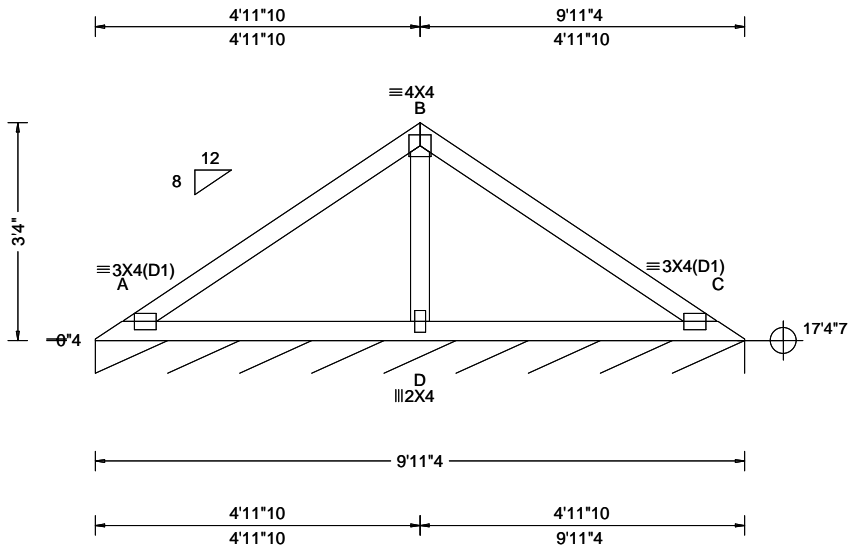

Loading Criteria (psf)	Wind Criteria	Snow Criteria (Pg,Pf in PSF)	Defl/CSI Criteria	▲ Maximum Reactions (lbs), or *=PLF
TCLL: 20.00 TCDL: 10.00 BCLL: 0.00 BCDL: 10.00 Des Ld: 40.00 NCBCLL: 10.00 Soffit: 2.00 Load Duration: 1.25 Spacing: 24.0 "	Wind Std: ASCE 7-22 Speed: 130 mph Enclosure: Enclosed Risk Category: II EXP: C Kzt: NA Mean Height: 19.19 ft TCDL: 5.0 psf BCDL: 5.0 psf MWFRS Parallel Dist: h to 2h C&C Dist a: 3.00 ft Loc. from endwall: not in 9.00 ft GCpi: 0.18 Wind Duration: 1.60	Pg: NA Ct: NA CAT: NA Pf: NA Ce: NA Lu: NA Cs: NA Snow Duration: NA Building Code: FBC 8th Ed. 2023 Res. TPI Std: 2014 Rep Fac: Yes FT/RT:20(0)/10(0) Plate Type(s): WAVE	PP Deflection in loc L/defl L/# VERT(LL): 0.012 A 999 240 VERT(CL): 0.025 A 999 180 HORZ(LL): -0.006 C - - HORZ(TL): 0.013 C - - Creep Factor: 2.0 Max TC CSI: 0.342 Max BC CSI: 0.287 Max Web CSI: 0.128 VIEW Ver: 24.02.00D.0611.08	Gravity Loc R+ / R- / Rh / Rw / U / RL C* 84 /- /- /43 /2 /9 Non-Gravity Wind reactions based on MWFRS C Brg Wid = 119 Min Req = - Bearing A is a rigid surface. Members not listed have forces less than 375# Maximum Web Forces Per Ply (lbs) Webs Tens.Comp. B - D 366 -541

Lumber

Top chord: 2x4 SP #2;
Bot chord: 2x4 SP #2;
Webs: 2x4 SP #3;

Wind

Wind loads based on MWFRS with additional C&C member design.
Wind loading based on both gable and hip roof types.

Additional Notes

See DWGS VALTN220723 and VAL180220723 for valley details.
The overall height of this truss excluding overhang is 3-4-0.



COA #0278

02/03/2026
Florida Certificate of Product Approval #FL 1999

****WARNING** READ AND FOLLOW ALL NOTES ON THIS DRAWING!**
****IMPORTANT** FURNISH THIS DRAWING TO ALL CONTRACTORS INCLUDING THE INSTALLERS**
Trusses require extreme care in fabricating, handling, shipping, installing and bracing. Refer to and follow the latest edition of BCSI (Building Component Safety Information, by TPI and SBCA) for safety practices prior to performing these functions. Installers shall provide temporary bracing per BCSI. Unless noted otherwise, top chord shall have properly attached structural sheathing and bottom chord shall have a properly attached rigid ceiling. Locations shown for permanent lateral restraint of webs shall have continuous lateral restraint (CLR), installed with diagonal bracing installed on the CLR per BCSI sections B3, B7, or B10, as applicable. Apply plates to each face of truss and position as shown above and on the Joint Details, unless noted otherwise. Refer to drawings 160A-Z for standard plate positions. Refer to job's General Notes page for additional information.
Alpine, a division of ITW Building Components Group Inc. shall not be responsible for any deviation from this drawing, any failure to build the truss in conformance with ANSI/TPI 1, or for handling, shipping, installation and bracing of trusses. A seal on this drawing or cover page listing this drawing, indicates acceptance of professional engineering responsibility solely for the design shown. The suitability and use of this drawing for any structure is the responsibility of the Building Designer per ANSI/TPI 1 Sec.2.
For more information see these web sites: Alpine: alpineitw.com; TPI: tpinst.org; SBCA: sbccomponents.com; ICC: iccsafe.org; AWC: awc.org



SEQN: 430510 FROM: RFG	VAL Ply: 1 Qty: 1	Job Number: 26-3432 MOORE Truss Label: V07	Cust: R215 JRef: 1YH82150009 T43 DrwNo: 030.26.1739.47233 GA / WHK 01/30/2026
---------------------------	-------------------------	--	---

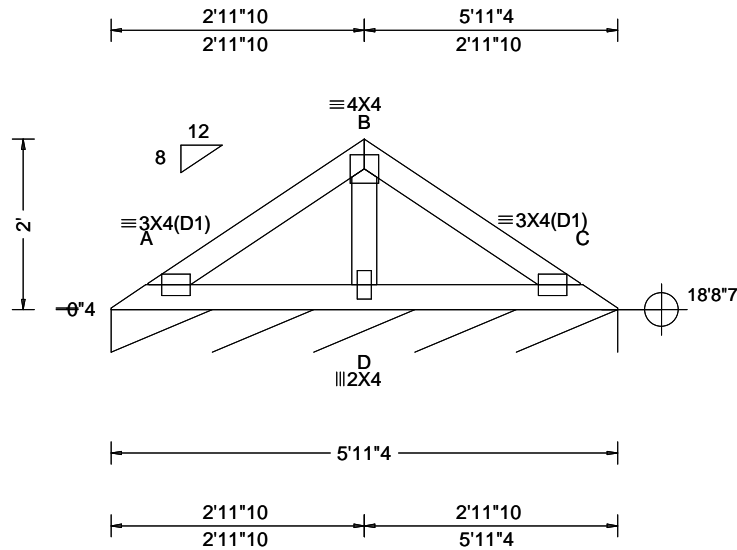

Loading Criteria (psf) TCLL: 20.00 TCDL: 10.00 BCLL: 0.00 BCDL: 10.00 Des Ld: 40.00 NCBCLL: 10.00 Soffit: 2.00 Load Duration: 1.25 Spacing: 24.0 "	Wind Criteria Wind Std: ASCE 7-22 Speed: 130 mph Enclosure: Enclosed Risk Category: II EXP: C Kzt: NA Mean Height: 19.86 ft TCDL: 5.0 psf BCDL: 5.0 psf MWFRS Parallel Dist: h to 2h C&C Dist a: 3.00 ft Loc. from endwall: not in 9.00 ft GCp: 0.18 Wind Duration: 1.60	Snow Criteria (Pg,Pf in PSF) Pg: NA Ct: NA CAT: NA Pf: NA Ce: NA Lu: NA Cs: NA Snow Duration: NA Building Code: FBC 8th Ed. 2023 Res. TPI Std: 2014 Rep Fac: Yes FT/RT:20(0)/10(0) Plate Type(s): WAVE	Defl/CSI Criteria PP Deflection in loc L/defl L/# VERT(LL): 0.002 A 999 240 VERT(CL): 0.005 A 999 180 HORZ(LL): -0.001 C - - HORZ(TL): 0.003 C - - Creep Factor: 2.0 Max TC CSI: 0.103 Max BC CSI: 0.087 Max Web CSI: 0.066 VIEW Ver: 24.02.00D.0611.08	▲ Maximum Reactions (lbs), or *=PLF Gravity Non-Gravity Loc R+ / R- / Rh / Rw / U / RL C* 83 /- /- /42 /1 /8 Wind reactions based on MWFRS C Brg Wid = 71.2 Min Req = - Bearing A is a rigid surface. Members not listed have forces less than 375#
--	--	--	--	---

Lumber

Top chord: 2x4 SP #2;
Bot chord: 2x4 SP #2;
Webs: 2x4 SP #3;

Wind

Wind loads based on MWFRS with additional C&C member design.
Wind loading based on both gable and hip roof types.

Additional Notes

See DWGS VALTN220723 and VAL180220723 for valley details.
The overall height of this truss excluding overhang is 2'-0-0.

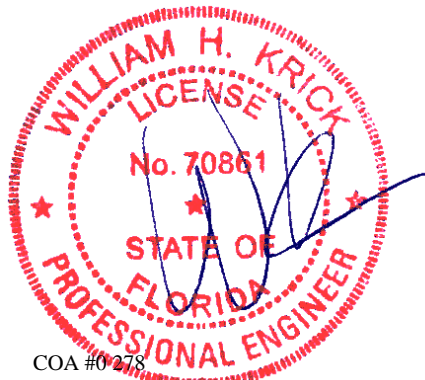

COA #0278

02/02/2026 Florida Certificate of Product Approval #FL 1999

****WARNING** READ AND FOLLOW ALL NOTES ON THIS DRAWING!**
****IMPORTANT** FURNISH THIS DRAWING TO ALL CONTRACTORS INCLUDING THE INSTALLERS**
Trusses require extreme care in fabricating, handling, shipping, installing and bracing. Refer to and follow the latest edition of BCSI (Building Component Safety Information, by TPI and SBCA) for safety practices prior to performing these functions. Installers shall provide temporary bracing per BCSI. Unless noted otherwise, top chord shall have properly attached structural sheathing and bottom chord shall have a properly attached rigid ceiling. Locations shown for permanent lateral restraint of webs shall have continuous lateral restraint (CLR), installed with diagonal bracing installed on the CLR per BCSI sections B3, B7, or B10, as applicable. Apply plates to each face of truss and position as shown above and on the Joint Details, unless noted otherwise. Refer to drawings 160A-Z for standard plate positions. Refer to job's General Notes page for additional information.
Alpine, a division of ITW Building Components Group Inc. shall not be responsible for any deviation from this drawing, any failure to build the truss in conformance with ANSI/TPI 1, or for handling, shipping, installation and bracing of trusses. A seal on this drawing or cover page listing this drawing, indicates acceptance of professional engineering responsibility solely for the design shown. The suitability and use of this drawing for any structure is the responsibility of the Building Designer per ANSI/TPI 1 Sec.2.
For more information see these web sites: Alpine: alpineitw.com; TPI: tpinst.org; SBCA: sbcacomponents.com; ICC: iccsafe.org; AWC: awc.org



Piggyback Detail - ASCE 7-22: 160 mph, 30' Mean Height, Enclosed, Exposure C, Kzt=1.00

160 mph Wind, 30.00 ft Mean Hgt, ASCE 7-22, Enclosed Bldg. located anywhere in roof, Exp C, Wind DL= 5.0 psf (min), Kzt=1.0.
 Or 140 mph wind, 30.00 ft Mean Hgt, ASCE 7-22, Enclosed Bldg. located anywhere in roof, Exp D, wind DL= 5.0 psf (min), Kzt=1.0.

Note: Top chords of trusses supporting piggyback cap trusses must be adequately braced by sheathing or purlins. The building designer shall provide diagonal bracing or any other suitable anchorage to permanently restrain purlins, and lateral bracing for out of plane loads over gable ends.

Maximum truss spacing is 24' o.c. Detail is not applicable if cap supports additional loads such as cupola, steeple, chimney or drag strut loads.

** Refer to Engineer's sealed truss design drawing for piggyback and base truss specifications.

Detail A : Purlin Spacing = 24" o.c. or less

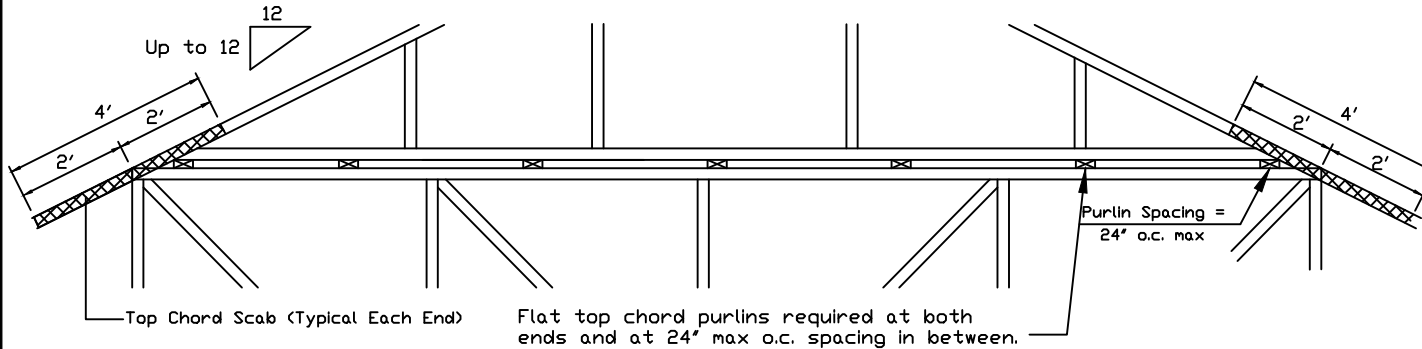

Piggyback cap truss slant nailed to all top chord purlin bracing with (2) 16d box nails (0.135"x3.5") and secure top chord with 2x4 #3 grade scab (1 side only at each end) attached with 2 rows of 10d box nails (0.128"x3") at 4' o.c.

Attach purlin bracing to the flat top chord using (2) 16d box nails (0.135"x3.5").

The top chord #3 grade 2x4 scab may be replaced with either of the following: (1) 3X8 Trulox plate attached with (8) 0.120"x1.375" nails, (4) into cap TC & (4) into base truss TC or (1) 28PB wave piggyback plate plated to the piggyback truss TC and attached to the base truss TC with (4) 0.120"x1.375" nails. Note: Nailing thru holes of wave plate is acceptable.

Detail B : Purlin Spacing > 24" o.c.

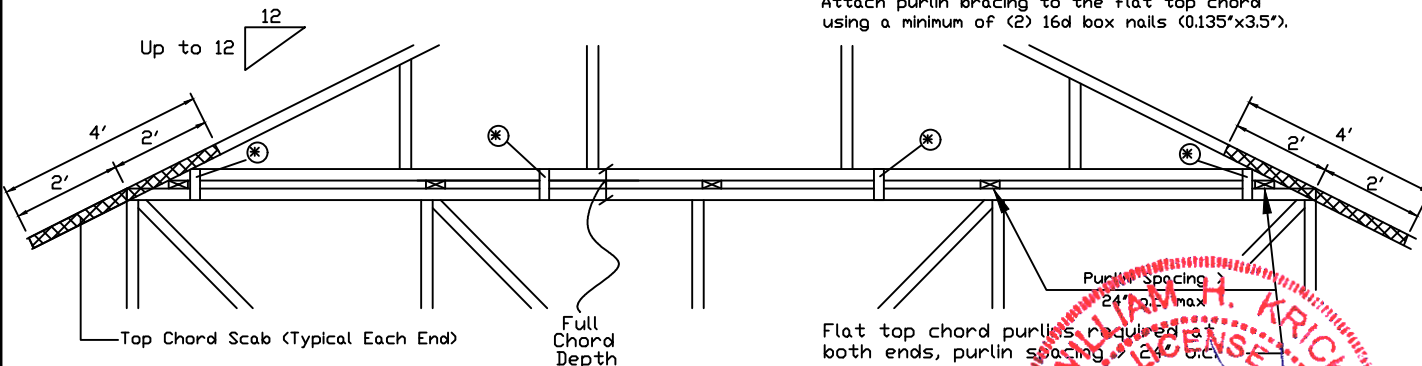

Piggyback cap truss slant nailed to all top chord purlin bracing with (2) 16d box nails (0.135"x3.5") and secure top chord with 2x4 #3 grade scab (1 side only at each end) attached with 2 rows of 10d box nails (0.128"x3") at 4' o.c.

Attach purlin bracing to the flat top chord using a minimum of (2) 16d box nails (0.135"x3.5").

* In addition, provide connection with one of the following methods:

- Trulox**
Use 3X8 Trulox plates for 2x4 chord member, and 3X10 Trulox plates for 2x6 and larger chord members. Attach to each face @ 8' o.c. with (4) 0.120"x1.375" nails into cap bottom chord and (4) in base truss top chord. Trulox plates may be staggered 4' o.c. front to back faces.
- APA Rated Gusset**
8"x8"x7/16" (min) APA rated sheathing gussets (each face). Attach @ 8' o.c. with (8) 6d common (0.113"x2") nails per gusset, (4) in cap bottom chord and (4) in base truss top chord. Gussets may be staggered 4' o.c. front to back faces.
- 2x4 Vertical Scabs**
2x4 SPF #2, full chord depth scabs (each face). Attach @ 8' o.c. with (6) 10d box nails (0.128"x3") per scab, (3) in cap bottom chord and (3) in base truss top chord. Scabs may be staggered 4' o.c. front to back faces.
- 28PB Wave Piggyback Plate**
One 28PB wave piggyback plate to each face @ 8' o.c. Attach teeth to piggyback at time of fabrication. Attach to supporting truss with (4) 0.120"x1.375" nails per face per ply. Piggyback plates may be staggered 4' o.c. front to back faces.

Note: If purlins or sheathing are not specified on the flat top of the base truss, purlins must be installed at 24' o.c. max. and use Detail A.

WARNING: READ AND FOLLOW ALL NOTES ON THIS DRAWING. IMPORTANT: FURNISH THIS DRAWING TO ALL CONTRACTORS INCLUDING THE INSTALLERS.

Trusses require extreme care in fabricating, handling, shipping, installing and bracing. Refer to and follow the latest edition of BCSI (Building Component Safety Information, by TPI and SBCA) for safety practices prior to performing these functions. Installers shall provide temporary bracing per BCSI. Unless noted otherwise, top chord shall have properly attached structural sheathing and bottom chord shall have a properly attached rigid ceiling. Locations shown for permanent lateral restraint of truss shall have bracing installed per BCSI sections B3, B7 or B10, as applicable. Apply plates to each face of truss and position as shown above and on the Joint Details, unless noted otherwise. Refer to drawings 160A-Z for standard plate positions.

Alpine, a division of ITW Building Components Group Inc. shall not be responsible for any deviation from this drawing, any failure to build the truss in conformance with ANSI/TPI 1, or for handling, shipping, installation & bracing of trusses.

A seal on this drawing or cover page listing this drawing, indicates acceptance of professional engineering responsibility solely for the design shown. The suitability and use of this drawing for any structure is the responsibility of the Building Designer per ANSI/TPI 1 Sec.2.

For more information see this Job's general notes page and these web sites:
 ALPINE: www.alpineitw.com; TPI: www.tpinst.org; SBCA: www.sbcacomponents.com; ICC: www.iccsafe.org



155 Harlem Ave
 North Building, 4th Floor
 Glenview, IL 60025

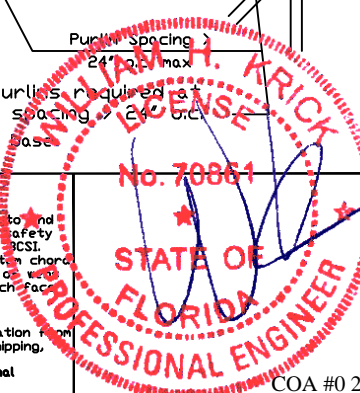

COA #0 278
 Florida Certificate of Product Approval #FL-1999

02/02/2026
 SPACING 24.0"

REF PIGGYBACK
 DATE 07/03/2023
 DRWG PB160220723

Valley Detail - ASCE 7-22: 180 mph, 30' Mean Height, Partially Enclosed, Exp. C, Kzt=1.00

Top Chord 2x4 SP #2N, SPF #1/#2, DF-L #2 or better.
 Bot Chord 2x4 SP #2N or SPF #1/#2 or better.
 Webs 2x4 SP #3, SPF #1/#2, DF-L #2 or better.

** Attach each valley to every supporting truss with:
 535# connection or with (1) Simpson H2.5A or equivalent connector for
 ASCE 7-22 180 mph. 30' Mean Height, Part. Enc. Building, Exp. C, Wind TC DL=5 psf, Kzt = 1.00
 Or
 ASCE 7-22 160 mph. 30' Mean Height, Part. Enc. Building, Exp. D, Wind TC DL=5 psf, Kzt = 1.00

Bottom chord may be square or pitched cut as shown.

Valleys short enough to be cut as solid triangular members from a single 2x6, or larger as required, shall be permitted in lieu of fabricating from separate 2x4 members.

All plates shown are Alpine Wave Plates.

Unless specified otherwise on engineer's sealed design, for vertical valley webs taller than 7-9" apply 2x4 "T" reinforcement, 80% length of web, same species and grade or better, attached with 10d box (0.128" x 3.0") nails at 6" o.c. In lieu of "T" reinforcement, 2x4 Continuous Lateral Restraint applied at mid-length of web is permitted with diagonal bracing as shown in DRWG BRCLBANC1014.

Top chord of truss beneath valley set must be braced with:
 properly attached, rated sheathing applied prior to valley truss installation.

Or
 Purlins at 24" o.c. or as otherwise specified on engineer's sealed design

Or
 By valley trusses used in lieu of purlin spacing as specified on Engineer's sealed design.

*** Note that the purlin spacing for bracing the top chord of the truss beneath the valley is measured along the slope of the top chord.

++ Larger spans may be built as long as the vertical height does not exceed 14'-0".

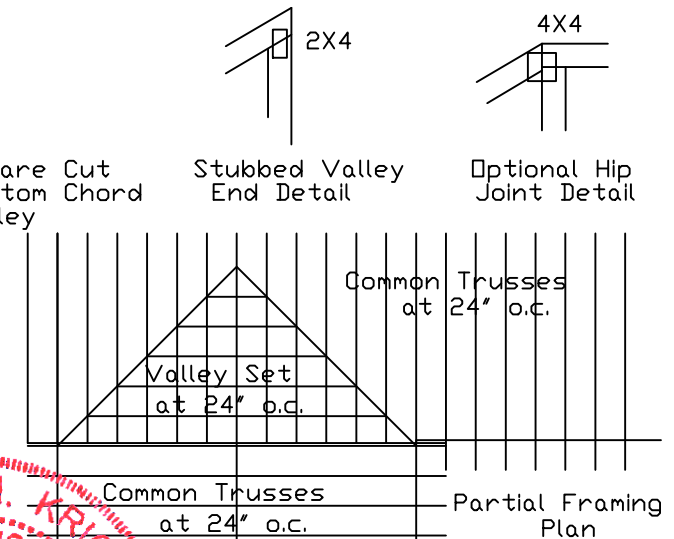
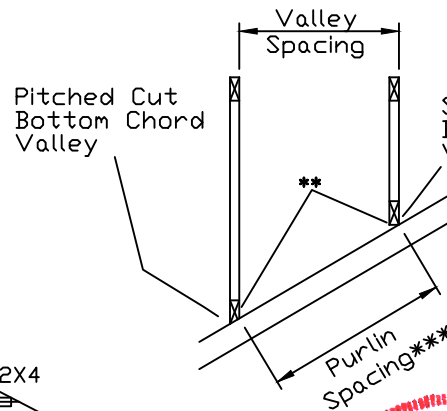
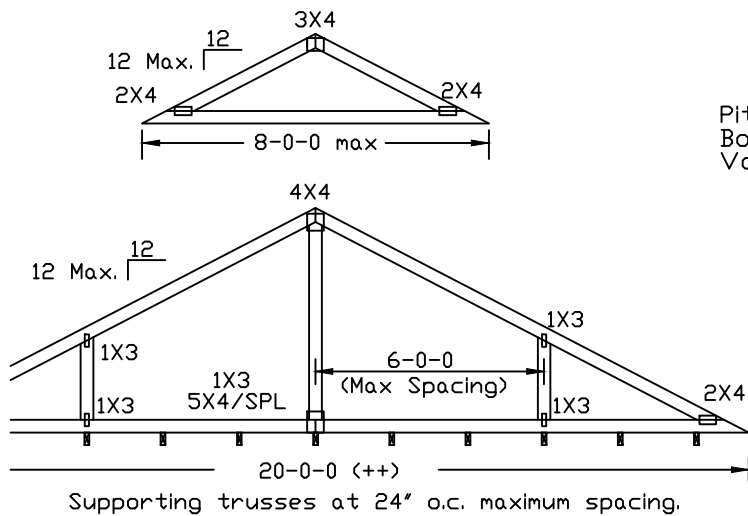

WARNING: READ AND FOLLOW ALL NOTES ON THIS DRAWING
IMPORTANT: FURNISH THIS DRAWING TO ALL CONTRACTORS INCLUDING THE INSTALLERS.
 Trusses require extreme care in fabricating, handling, shipping, installing and bracing. Refer to and follow the latest edition of BCSI (Building Component Safety Information, by TPI and SBCA) for safety practices prior to performing these functions. Installers shall provide temporary bracing per BCSI. Unless noted otherwise, top chord shall have properly attached structural sheathing and bottom chord shall have a properly attached rigid ceiling. Locations shown for permanent lateral restraint of webs shall have bracing installed per BCSI sections B3, B7 or B10, as applicable. Apply plates to each face of truss and position as shown above and on the Joint Details, unless noted otherwise. Refer to drawings 160A-Z for standard plate positions.
 Alpine, a division of ITW Building Components Group Inc. shall not be responsible for any deviation from this drawing, any failure to build the truss in conformance with ANSI/TPI 1, or for handling, shipping, installation & bracing of trusses.
 A seal on this drawing or cover page listing this drawing, indicates acceptance of professional engineering responsibility solely for the design shown. The suitability and use of this drawing for any structure is the responsibility of the Building Designer per ANSI/TPI 1 Sec.2.
 For more information see this Job's general notes page and these web sites:
 ALPINE: www.alpineitw.com; TPI: www.tpinet.org; SBCA: www.sbcacomponents.com; ICC: www.iccsafe.org

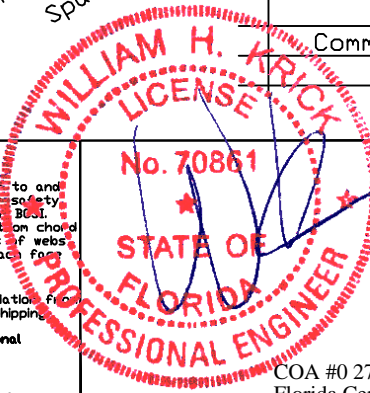

TC LL	30	30	40PSF	REF	VALLEY DETAIL
TC DL	20	15	7PSF	DATE	07/03/2023
BC DL	10	10	10 PSF	DRWG	VAL180220723
BC LL	0	0	0PSF		
TOT. LD.	60	55	57PSF		
DUR	50	1.25	1.33	1.15	1.15
SPACING	24.01				

COA #0 278
 Florida Certificate of Inspection Approval #FL 1999

Valley Detail - ASCE 7-22: 30' Mean Height, Enclosed, Exp. C, Kzt=1.00

Top Chord 2x4 SP #2N, SPF #1/#2, DF-L #2 or better.
 Bot Chord 2x4 SP #2N or SPF #1/#2 or better.
 Webs 2x4 SP #3, SPF #1/#2, DF-L #2 or better.

** Attach each valley to every supporting truss with:
 (2) 16d box (0.135" x 3.5") nails toe-nailed for
 ASCE 7-22, 30' Mean Height, Enclosed Building, Exp. C,
 Wind TC DL=5 psf, Kzt = 1.00, Max. Wind Speed based on
 supporting truss material at connection location:
 140 mph for SP (G = 0.55, min.),
 125 mph for DF-L (G = 0.50, min.), or
 105 mph for HF & SPF (G = 0.42, min.).

Maximum top chord pitch is 10/12 for supporting trusses
 below valley trusses.

Bottom chord of valley trusses may be square or
 pitched cut as shown.

Valleys short enough to be cut as solid triangular
 members from a single 2x6, or larger as required,
 shall be permitted in lieu of fabricating from
 separate 2x4 members.

All plates shown are Alpine Wave Plates.

Unless specified otherwise on engineer's sealed design, for vertical
 valley webs taller than 7'-9" apply 2x4 "T" reinforcement, 80% length of
 web, same species and grade or better, attached with 10d box
 (0.128" x 3.0") nails at 6" o.c. In lieu of "T" reinforcement, 2x4 Continuous
 Lateral Restraint applied at mid-length of web is permitted with diagonal
 bracing as shown in DRWG BRCLBANC1014.

Top chord of truss beneath valley set must be braced with:
 properly attached, rated sheathing applied prior to valley truss
 installation.

- Or
- Purlins at 24" o.c. or as otherwise specified on engineer's sealed design
- Or
- By valley trusses in lieu of purlin spacing as specified on
 Engineer's sealed design.

*** Note that the purlin spacing for bracing the top chord of the truss
 beneath the valley is measured along the slope of the top chord.

++ Larger spans may be built as long as the vertical height does
 not exceed 14'-0".

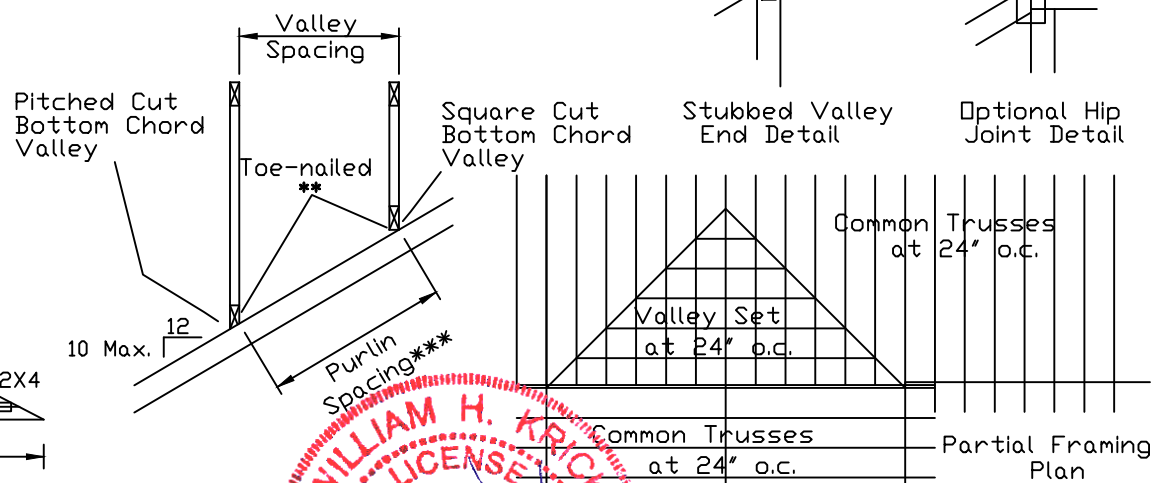
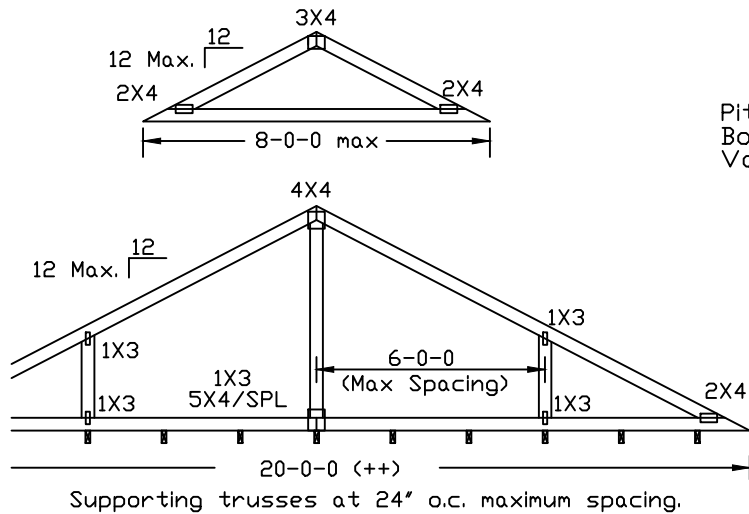

WARNING: READ AND FOLLOW ALL NOTES ON THIS DRAWING
IMPORTANT: FURNISH THIS DRAWING TO ALL CONTRACTORS INCLUDING THE INSTALLERS.
 Trusses require extreme care in fabricating, handling, shipping, installing and bracing. Refer to and follow the latest edition of BCSI (Building Component Safety Information, by TPI and SBCA) for safety practices prior to performing these functions. Installers shall provide temporary bracing per BCSI. Unless noted otherwise, top chord shall have properly attached structural sheathing and bottom chord shall have a properly attached rigid ceiling. Locations shown for permanent lateral restraint of webs shall have bracing installed per BCSI sections B3, B7 or B10, as applicable. Apply plates to each face of truss and position as shown above and on the Joint Details, unless noted otherwise. Refer to drawings 160A-Z for standard plate positions.
 Alpine, a division of ITW Building Components Group Inc. shall not be responsible for any deviation from this drawing, any failure to build the truss in conformance with ANSI/TPI 1, or for handling, shipping, installation & bracing of trusses.
 A seal on this drawing or cover page listing this drawing, indicates acceptance of professional engineering responsibility solely for the design shown. The suitability and use of this drawing for any structure is the responsibility of the Building Designer per ANSI/TPI 1 Sec.2.
 For more information see this Job's general notes page and these web sites:
 ALPINE: www.alpineitw.com; TPI: www.tpinst.org; SBCA: www.sbcacomponents.com; ICC: www.iccsafe.org

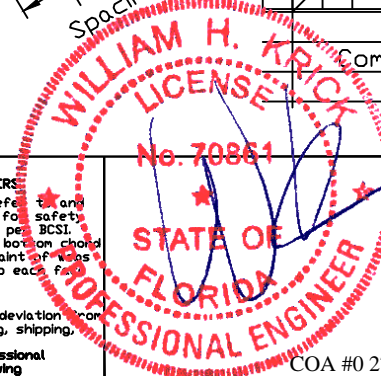

TC LL	30	30	40PSF	REF	VALLEY DETAIL
TC DL	20	15	7PSF	DATE	07/03/2023
BC DL	10	10	10PSF	DRWG	VALTN220723
BC LL	0	0	0PSF		
TOT. LD.	60	55	57PSF		
				02/02/2026	
				DUR.FAC.1.25/1.33	1.15/1.15
				SPACING	24.0"

COA #0 278
 Florida Certificate of Product Approval #FL 1999