



DBPR HOME ABOUT DBPR DBPR DIVISIONS CONTACT DBPR

BCIS Home | Log In | User Registration | Hot Topics | Submit Surcharge | Stats & Facts | Publications | Contact Us | BCIS Site Map | Links | Search



Product Approval

USER: Public User

[Product Approval Menu](#) > [Product or Application Search](#) > [Application List](#) > **Application Detail**

OFFICE OF THE SECRETARY

FL #	FL10124-R36
Application Type	Revision
Code Version	2023
Application Status	Approved
Comments	
Archived	<input type="checkbox"/>
Product Manufacturer	GAF
Address/Phone/Email	1 Campus Drive Parisppany, NJ 07054 (800) 766-3411 mstieh@gaf.com
Authorized Signature	Michael Stieh michael.stieh@gaf.com
Technical Representative	William Broussard
Address/Phone/Email	1 Campus Drive Parsippany, NJ 07054 (800) 766-3411 TechnicalQuestionsGAF@gaf.com
Quality Assurance Representative	
Address/Phone/Email	

Category	Roofing														
Subcategory	Asphalt Shingles														
Compliance Method	Evaluation Report from a Florida Registered Architect or a Licensed Florida Professional Engineer <input type="checkbox"/> Evaluation Report - Hardcopy Received														
Florida Engineer or Architect Name who developed the Evaluation Report	Robert Nieminen														
Florida License	PE-59166														
Quality Assurance Entity	UL LLC														
Quality Assurance Contract Expiration Date	12/16/2025														
Validated By	John W. Knezevich, PE <input checked="" type="checkbox"/> Validation Checklist - Hardcopy Received														
Certificate of Independence	FL10124_R36_COI_2024_07_COI_NIEMINEN.pdf														
Referenced Standard and Year (of Standard)	<table> <thead> <tr> <th><u>Standard</u></th> <th><u>Year</u></th> </tr> </thead> <tbody> <tr> <td>ASTM D1970</td> <td>2017</td> </tr> <tr> <td>ASTM D3161</td> <td>2016</td> </tr> <tr> <td>ASTM D3462</td> <td>2016</td> </tr> <tr> <td>ASTM D7158</td> <td>2019</td> </tr> <tr> <td>TAS 100</td> <td>2023</td> </tr> <tr> <td>TAS 107</td> <td>2020</td> </tr> </tbody> </table>	<u>Standard</u>	<u>Year</u>	ASTM D1970	2017	ASTM D3161	2016	ASTM D3462	2016	ASTM D7158	2019	TAS 100	2023	TAS 107	2020
<u>Standard</u>	<u>Year</u>														
ASTM D1970	2017														
ASTM D3161	2016														
ASTM D3462	2016														
ASTM D7158	2019														
TAS 100	2023														
TAS 107	2020														
Equivalence of Product Standards Certified By															
Sections from the Code															
Product Approval Method	Method 1 Option D														

Date Submitted 01/31/2025
 Date Validated 02/06/2025
 Date Pending FBC Approval 02/10/2025
 Date Approved 04/15/2025

Summary of Products

FL #	Model, Number or Name	Description
10124.1	GAF Asphalt Roof Shingles (HVHZ)	Fiberglass reinforced, laminated asphalt shingles for use in FBC HVHZ jurisdictions.
Limits of Use Approved for use in HVHZ: Yes Approved for use outside HVHZ: No Impact Resistant: N/A Design Pressure: N/A Other: Refer to PEER-GAF-002.B, Section 5 for Limits of Use.		Installation Instructions FL10124 R36 II 2025 01 16 FINAL PEER-GAF-002.B SHINGLES HVHZ FL10124-R36.pdf Verified By: Robert Nieminen PE-59166 Created by Independent Third Party: Yes Evaluation Reports FL10124 R36 AE 2025 01 16 FINAL PEER-GAF-002.B SHINGLES HVHZ FL10124-R36.pdf Created by Independent Third Party: Yes
10124.2	GAF Asphalt Roof Shingles (NON-HVHZ)	Fiberglass reinforced 3-tab, laminated, 5-tab and hip/ridge asphalt shingles for use in FBC non-HVHZ jurisdictions.
Limits of Use Approved for use in HVHZ: No Approved for use outside HVHZ: Yes Impact Resistant: N/A Design Pressure: N/A Other: Refer to PEER-GAF-002.A, Section 5 for Limits of Use.		Installation Instructions FL10124 R36 II 2025 01 16 FINAL PEER-GAF-002.A SHINGLES NON-HVHZ FL10124-R36.pdf Verified By: Robert Nieminen PE-59166 Created by Independent Third Party: Yes Evaluation Reports FL10124 R36 AE 2025 01 16 FINAL PEER-GAF-002.A SHINGLES NON-HVHZ FL10124-R36.pdf Created by Independent Third Party: Yes

[Back](#)

[Next](#)

[Contact Us](#) :: [2601 Blair Stone Road, Tallahassee FL 32399](#) Phone: 850-487-1824

The State of Florida is an AA/EEO employer. [Copyright 2007-2013 State of Florida.](#) :: [Privacy Statement](#) :: [Accessibility Statement](#) :: [Refund Statement](#)

Under Florida law, email addresses are public records. If you do not want your e-mail address released in response to a public-records request, do not send electronic mail to this entity. Instead, contact the office by phone or by traditional mail. If you have any questions, please contact 850.487.1395. *Pursuant to Section 455.275(1), Florida Statutes, effective October 1, 2012, licensees licensed under Chapter 455, F.S. must provide the Department with an email address if they have one. The emails provided may be used for official communication with the licensee. However email addresses are public record. If you do not wish to supply a

personal address, please provide the Department with an email address which can be made available to the public. To determine if you are a licensee under Chapter 455, F.S., please click [here](#).

Product Approval Accepts:





NEMO|etc.

Certificate of Authorization #32455
353 Christian Street, Unit #13
Oxford, CT 06478
(203) 262-9245

ENGINEER

TEST

CONSULT

P.E. EVALUATION REPORT (PEER)

GAF

1 Campus Drive
Parsippany, NJ 07054
(800) 766-3411

PEER-GAF-002.B.R2

FL10124-R36 (HVHZ)

Date of Issuance: 06/20/2023

Revision 2: 01/16/2025

SCOPE:

This P.E. Evaluation Report (henceforth 'PEER') is issued under **F.A.C. Rule 61G20-3** and the applicable rules and regulations governing the use of construction materials in the State of Florida. The documentation submitted has been reviewed by Robert Nieminen, P.E. for use of the product under the Florida Building Code. The product described herein has been evaluated for compliance with the **8th Edition (2023) Florida Building Code, High Velocity Hurricane Zone (HVHZ)** [sections noted herein](#).

DESCRIPTION: GAF Asphalt Roof Shingles (HVHZ)

LABELING: Labeling shall be in accordance with the requirements of the Accredited Quality Assurance Agency noted herein and **FBC 1523.5.1**.

CONTINUED COMPLIANCE: This PEER is valid until such time as the named product(s) changes, the referenced Quality Assurance or production facility location(s) changes, or Code provisions that relate to the product(s) change. Acceptance of our PEERs by the named client constitutes agreement to notify NEMO ETC, LLC of any changes to the product(s), the Quality Assurance or the production facility location(s). NEMO ETC, LLC requires a complete review of its PEER relative to updated Code requirements with each Code Cycle.

ADVERTISEMENT: "NEMO P.E. Evaluated" may be displayed in advertising literature. If any portion of the PEER is displayed, then it shall be in its entirety.

INSPECTION: Upon request, a copy of this entire PEER shall be provided to the user by the manufacturer or its distributors and shall be available for inspection at the job site at the request of the Building Official.

This PEER consists of pages 1 through 3.

Prepared by:

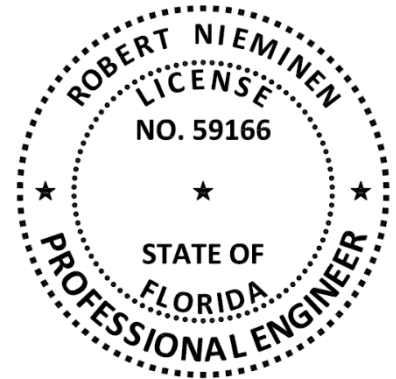

CERTIFICATION OF INDEPENDENCE:

1. NEMO ETC, LLC does not have, nor does it intend to acquire or will it acquire, a financial interest in any company manufacturing or distributing products it evaluates.
2. NEMO ETC, LLC is not owned, operated or controlled by any company manufacturing or distributing products it evaluates.
3. Robert Nieminen, P.E. does not have nor will acquire, a financial interest in any company manufacturing or distributing products for which the PEERs are being issued.
4. Robert Nieminen, P.E. does not have, nor will acquire, a financial interest in any other entity involved in the approval process of the product.
5. This is a building code evaluation. Neither NEMO ETC, LLC nor Robert Nieminen, P.E. are, in any way, the Designer of Record for any project on which this PEER, or previous versions thereof, is/was used for permitting or design guidance unless retained specifically for that purpose.

ROOFING SYSTEMS EVALUATION:

1. SCOPE:

Product Category: Roofing
Sub-Category: Asphalt Shingles
Product Approval Method: Method 1, Option D – Codified Material, Evaluation by Engineer
Compliance Statement: **GAF Asphalt Roof Shingles**, as produced by **GAF**, have demonstrated compliance with the following sections of the **8th Edition (2023) Florida Building Code, High Velocity Hurricane Zone (HVHZ)** through testing in accordance with the following Standards. Compliance is subject to the [Installation Requirements](#) and [Limitations of Use](#) set forth herein.

2. STANDARDS:

SECTION	PROPERTY	STANDARD
1523.6.5.1, TAS 110	Material standard	ASTM D3462
1523.6.5.1, TAS 110	Wind Driven Rain	TAS 100
1523.6.5.1, TAS 110	Wind Resistance	TAS 107

3. REFERENCES:

ENTITY	EXAMINATION	REFERENCE	DATE
Farabaugh ET (TST1654)	TAS 100	T174-22	04/11/2022
UL, LLC. (TST 9628)	ASTM D3161, D7158, D3462	4788198026	05/23/2022
UL, LLC. (QUA 9625)	Quality Control	Service Confirmation	12/06/2022
UL, LLC. (QUA 9625)	Quality Control	Florida BCIS	Current

4. PRODUCT DESCRIPTION:

TABLE 1: ASPHALT SHINGLE COMPONENTS			
PRODUCT	DESCRIPTION	MATERIAL STANDARD	PLANT(S)
Timberline® Solar HDZ®	fiberglass reinforced, laminated asphalt roof shingles	ASTM D3462	IN-MV

5. LIMITATIONS:

- 5.1 This is a building code evaluation. Neither NEMO ETC, LLC nor Robert Nieminen, P.E. are, in any way, the Designer of Record for any project on which this PEER, or previous versions thereof, is/was used for permitting or design guidance. PEERs are not to be construed as representing any attributes not specifically listed, nor are PEERs to be construed as an endorsement of the subject, or a recommendation for its use. There is no warranty by NEMO ETC, LLC or Robert Nieminen, P.E., express or implied, as to any finding or other matter in this PEER, or as to any product covered by the PEER.
- 5.2 This PEER is exclusively for use in FBC High Velocity Hurricane Zone jurisdictions, as defined in FBC Chapter 2 (Broward and Miami-Dade Counties).
- 5.3 This PEER pertains to above-deck roof components. Roof decks and structural members shall be in accordance with FBC requirements to the satisfaction of the Authority Having Jurisdiction.
- 5.4 This PEER does not include evaluation of fire classification. Refer to **FBC 1516** for requirements and limitations regarding roof assembly fire classification. Refer to **FBC 2603** for requirements and limitations concerning the use of foam plastic insulation.
- 5.5 **Wind Classification:** Refer to [Section 6](#) for installation requirements to meet wind classifications

TABLE 2: WIND CLASSIFICATIONS, ASPHALT SHINGLES		
PRODUCT	FBC 1523.6.5.1	MEAN ROOF HEIGHT
Timberline® Solar HDZ®	TAS 107	Max. 33 ft

5.6 All components in the roof assembly shall have quality assurance audit in accordance with **F.A.C. Rule 61G20-3**. Refer to the Product Approval of the component manufacturer for components that are produced by a Product Manufacturer other than the report holder on [Page 1](#) of this PEER.

6. INSTALLATION:

6.1 GENERAL:

- 6.1.1 Roof deck, slope, underlayment, fasteners, flashings and metal accessories shall comply with [Roofing Application Standard RAS 115](#) and the shingle manufacturer’s minimum requirements.
- 6.1.2 Underlayment shall be acceptable to GAF and shall hold current Florida Statewide Product Approval, or be Locally Approved per **F.A.C. Rule 61G20-3**, for use in FBC HVHZ jurisdictions, per **FBC Sections 1518.7.1** and [Roofing Application Standard RAS 115](#).

6.2 ASPHALT SHINGLES:

- 6.2.1 Installation of Timberline® Solar HDZ® shall comply with GAF current published instructions, using minimum six (6) nails per shingle in accordance with FBC 1518.7.3.2.
- 6.2.2 Fasteners shall be in accordance with manufacturer’s published requirements, but not less than [Roofing Application Standard RAS 115](#). Staples are not permitted.
- 6.2.3 The following depict nail-placement locations for Timberline® Solar HDZ® designed with a ‘target nail zone’. Where the roof slope exceeds 21 units vertical in 12 units horizontal, special methods of fastening are required. Contact GAF for details.

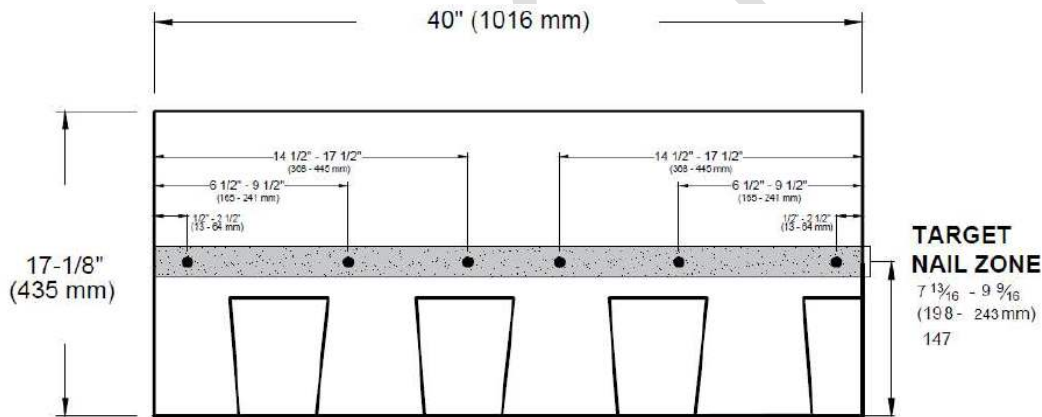

7. BUILDING PERMIT REQUIREMENTS:

As required by the Building Official or Authority Having Jurisdiction to properly evaluate the installation of this product.

8. MANUFACTURING PLANTS:

Contact the named QA entity for manufacturing facilities covered by **F.A.C. Rule 61G20-3** QA requirements. Refer to [Section 4](#) herein for products and production locations having met codified material standards.

9. QUALITY ASSURANCE ENTITY:

[UL \(QUA9625\)](#): (360) 817-5512; bsai.inspections@ul.com

- END OF PEER -