

ULTIMATE & NOMINAL WIND SPEEDS	
ULTIMATE	NOMINAL SUSTAINED
120	93
130	101
140	108
150	116

WIND EXPOSURE CATEGORY		
B	C	D

BUILDING DIMENSIONS D-1			
BARN WIDTH (FT)	INSIDE POST DIMENSION	OUTSIDE 6" X 6" POST DIMENSION	OUTSIDE 8" X 8" POST DIMENSION
40	39'-1"	40	40'-4"
36	35'-1"	36	36'-4"
30	29'-1"	30	30'-4"
24	23'-1"	24	24'-4"
20	19'-1"	20	20'-4"

BARN LENGTH (FT)	D-2	INSIDE DIMENSION FOR ROUND POST SEE D-1
	84'	
	72'	
	60'	
	50'	
	48'	
	40'	
	36'	
	30'	
	24'	

POST SIZE		
6" X 6"	8" X 8"	10" X 10"
ROUND MIN. DIA.		

ROOF PITCH			
3/12	4/12	5/12	6/12

POST HEIGHT SIZE CIRCLED OR LESS (D-3) OTHER				
10'	12'	14'	16'	

CONCRETE INFORMATION	
<b>CONCRETE SLAB</b>	
NO CONCRETE SLAB	
4" THICK 3000 PSI CONCRETE SLAB W/ 6X6- 6/6 WWF OR FIBERMESH CONCRETE DESIGN LIVE LOAD 40 PSF	
6" THICK 3000 PSI CONCRETE SLAB W/ 6X6 4/4 WWF CONCRETE DESIGN LIVE LOAD 200 PSF	
8" THICK 3000 PSI CONCRETE SLAB W/ 2 MATS OF BARS TOP & BOTTOM EACH #4 BARS @ 12" C/C EACH WAY CONCRETE DESIGN LIVE LOAD 400 PSF	
<b>THICKENED EDGE SLAB</b>	
NO THICKENED EDGE SLAB	
12" W X 12" D W/ 2 #5 BAR CONT	
12" W X 20" D W/ 2 #5 BAR CONT	
<b>RIBBON FOOTING</b>	
NO RIBBON FOOTING	
12" W X 12" D W/ 2 #5 BAR CONT	
12" W X 20" D W/ 2 #5 BAR CONT	

POST FOOTING SIZE	
F-1	24" DIA. X 48" DEEP
F-1	30" DIA. X 60" DEEP
ALL POST REQUIRE CONCRETE FOOTINGS	

PROFESSIONAL SERVICES BY  
DRISCOLL ENGINEERING, INC.  
PO BOX 357577  
GAINESVILLE, FL 32635  
PH (352)-331-1513  
CA 8690

**PLANS AND SPECIFICATIONS**  
The plans and specifications presented herein are applicable only for the anticipated construction at the locations shown. If construction plans change, the Design Professional should be notified so the plans and specifications can be re-evaluated. The Design Professional should be given the opportunity to review final plans and specifications to see if the intent of the plans and specifications has been followed and/or if supplemental details and recommendations are needed. The Design Professional warrants that the plans and specifications contained herein, have been prepared in accordance with generally accepted professional engineering practice. No other warranties are implied or expressed.

**CORPORATE PROTECTION**  
It is understood and agreed that the Design Professional's Basic Services under this Agreement do not include project observation or review of the Contractor's performance or any other construction phase services, and that such services will be provided by the Client. The Client assumes all responsibility for interpretation of the contractor Documents and for construction observation and supervision and waives any claims against the Design Professional that may be in any way connected thereto.

In addition, the Client agrees, to the fullest extent permitted by law, to indemnify and hold the Design Professional harmless from any loss, claim or cost, including reasonable attorney's fees and costs of defense, arising or resulting from the performance of such services by other person or entities and from any and all claims arising from modifications, clarifications, interpretations, adjustments or changes made to Contract Documents to reflect changed field or other conditions, except for claims arising from the sole negligence or willful misconduct to the Design Professional.

**OWNERSHIP OF INSTRUMENTS OF SERVICE**  
All reports, plans, specifications, computer files, field data, notes and other documents and instruments prepared by the Design Professional as instruments of service shall remain the property of the Design Professional. The Design Professional shall retain all common law, statutory and other reserved rights, including the copyright thereto.

**DEFECTS IN SERVICE**  
The Client shall promptly report to the Design Professional any defects or suspected defects in the Design Professional's work or services of which the Client becomes aware, so that the Design Professional may take measures to minimize the consequences of such a defect. The Client warrants that he or she will impose a similar notification requirement on all contractors in his or her Client/Contractor contract and shall require all subcontractors at any level to contain a like requirement. Failure by the Client, and the Client's contractors or subcontractors to notify the Design Professional, shall relieve the Design Professional of the costs of remedying the defects above the sum such remedy would have cost had prompt notification been given.

**VERIFICATION OF EXISTING CONDITIONS**  
Inasmuch as the remodeling and/or rehabilitation of an existing building requires that certain assumptions be made regarding existing conditions, and because some of these assumptions may not be verifiable without expending additional sums of money or destroying otherwise adequate or serviceable portions of the building, the Client agrees, to the fullest extent permitted by law, to indemnify and hold the Design Professional harmless from any claim, liability or cost (including reasonable attorney's fees and costs of defense) for injury or economic loss arising or allegedly arising out of the professional services provided under this Agreement, excepting only those damages, liabilities, or costs attributable to the sole negligence or willful misconduct of the Design Professional

All the plans in this building plan set are protected under the Federal Copyright Act, Title XVII of the U.S. Code and Chapter 37 of the Code of Federal Regulations. The owner of the copyright retains title and ownership of the original documents. The plan set licensed to you cannot be used by or resold to any other individual.

Reproduction of these plans, either in whole or in part, including any form of copying and/or preparation of derivative works thereof, for any reason without prior written permission, is strictly prohibited. The purchase of a set of building plans in no way transfers any copyright or other ownership interest in it to the buyer. The purchase of additional sets of that plan set at a reduced price from the original set or as part of a multiple set package does not convey to the buyer a license to construct more than one structure as shown. Similarly, the purchase of reproducible sets carries the same copyright protection. To use any plans more than once, and to avoid any copyright/license infringement, it is necessary to contact the plans' designer to receive a release and license for any extended usage. Whereas a purchaser of PDFs, CAD and Reproducibles is granted a license to make copies, it should be noted that as copyrighted material, making photocopies from the plan set is illegal.

Copyright licensing of plans for construction exists to protect all parties. It respects and supports the intellectual property of the original architect or designer. Copyright law has been reinforced over the past few years. Willful infringement could cause settlements for statutory damages up to \$150,000 plus attorney fees, damages, and loss of profits.

PURLIN SIZE	
2" X 6"	2" X 8"

POST SPACING D-4 (FT)			
8	10	12	15

METAL ROOF	
26 GA	29 GA
FL 42382.08-RO	

## OPEN POLE STORAGE STRUCTURE

1-All construction shall comply with Florida Building Code 8th edition 2023.

ULTIMATE WIND SPEED: SEE TABLE THIS SHEET  
NOMINAL WIND SPEED: SEE TABLE THIS SHEET  
WIND EXPOSURE CATEGORY: SEE TABLE THIS SHEET  
RISK CATEGORY I  
INTERNAL PRESSURE COEFFICIENT G<sub>cp</sub>= +/- 0.0  
DESIGN PRESSURE PER FBC CHAPTER 16, INCLUDING ASCE 7-22 LOAD CALCULATIONS  
ROOF LIVE LOAD = 12.5 PSF  
ROOF DEAD LOAD = 2.5 PSF  
MIN SOIL BEARING 2000 PSF  
MAX TRUSS BEARING LOAD EACH END 5200LB  
MAX TRUSS UPLIFT @ POST 3400LBS  
TERMITE TREATMENT SHALL BE APPLIED IN ACCORD WITH THE FLORIDA BUILDING CODE & LOCAL CODES  
Wood framing and fasteners to meet NDS-2018 requirements.

Fastener requirements: (1) all nails are common galvanized; (2) all bolts are to be galvanized steel and include nuts and washers; (3) all other hardware (Simpson or equal) is to be installed according to manufacturer's specifications and recommendations; (4) nailing (size and number) shall satisfy Tables 2306.2.(1), 2306.3.(1), and 2306.3.(#) unless otherwise indicated; (5) Fasteners exposed to the weather are to be treated for weather resistance and compatible with the type of pressure treated wood use (connectors, nails, bolts, nuts, & washers).

- Wood Pole Concrete Footings
  - Minimum Ultimate Compressive Strength @ 28 days = 3,000 PSI
  - Bag concrete mix allowed for wood pole footings when mixed in accord with manufactures requirements for a minimum ultimate compressive strength of 3,000 PSI
- Building Concrete Wall Footings & Slabs
  - Concrete work shall conform to "Building Code Requirements for Reinforced Concrete (ACI-318) and "Specifications for Structural Concrete" (ACI-301), Latest Edition
  - Minimum Ultimate Compressive Strength @ 28 days = 3,000 PSI
  - All slabs on grade shall have construction or control joints not to exceed 10'-0" spacing, unless otherwise noted.
  - Electrical conduit and other pipes to be embedded in structural concrete floor slabs or walls shall be placed in accordance with the requirements of ACI-318, Paragraph 6.3
- Reinforcing Steel
  - Reinforcing steel shall conform to ASTM A615, Grade 40 (Fy=40 ksi). Lap continuous bars for tension lap splice per ACI-318, unless otherwise noted. Provide corner bars of the same size and spacing as horizontal wall reinforcement. Cover for concrete reinforcing steel shall be in accordance with ACI-318, Paragraph 7.7
  - Welded wire fabric (WWF) shall conform to ASTM A185. Lap sheets two mesh spaces and wire tie adjacent sheets together securely. Cut alternate reinforcement at control joints.

The Structural Design Work in This Set of Engineering Plans Is Subject to But Not Limited to The Following Exclusions:

- Architectural Design Services
- Civil Engineering and Site Plan Design Services
- Electrical and Lighting Design Services
- HVAC Design Services
- Plumbing Design Services
- Geotechnical Engineering Services
- Life Safety Plan Design Services
- Flood Resistant Design Per Asce24-14
- Any and All Local Code Requirements and Comments Made by The Authority Having Jurisdiction with The Regard To The Plans And Specifications

These Exclusions Are All the Owner's Responsibility

OWNER /CONTRACTOR SHALL VERIFY ALL DIMENSIONS OF THIS STRUCTURE BEFORE BEGINNING CONSTRUCTION

THIS ITEM HAS BEEN ELECTRONICALLY SIGNED AND SEALED BY MICHAEL E. DRISCOLL, P.E. USING A SHA AUTHENTICATION CODE. PRINTED COPIES OF THIS DOCUMENT ARE NOT CONSIDERED SIGNED AND SEALED AND THE SHA AUTHENTICATION CODE MUST BE VERIFIED ON ANY ELECTRONIC COPIES ON 11-19-25

HIGHLIGHTED AREAS SELECTED ARE CHOSEN BY DRISCOLL ENGINEERING

SHEET: 1 OF 3



JAMES SMITH 11-19-25  
PARCEL # 0000000879000  
FORT WHITE, FL 32038  
DB25-821 40x60x16 DD

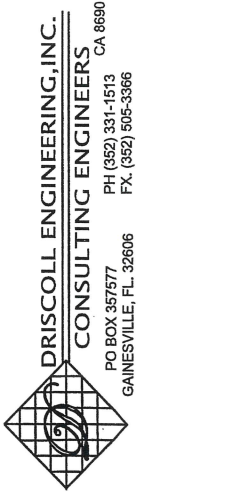

Michael E Driscoll PE  
FL Reg # 43922

STRUCTURAL ONLY

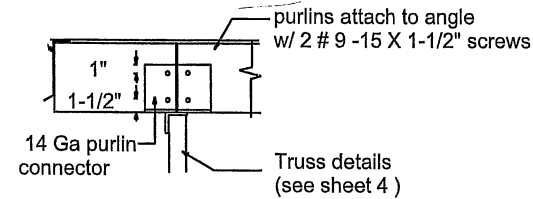

**PURLIN CONNECTION DETAIL**

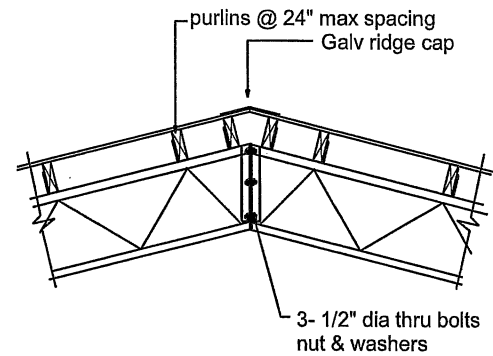

**RIDGE CONNECTION DETAIL**

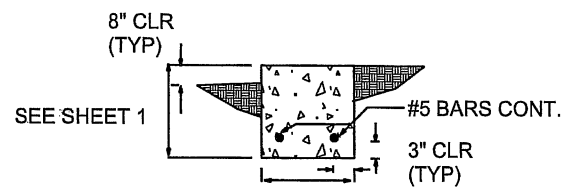

**RIBBON FOOTING**

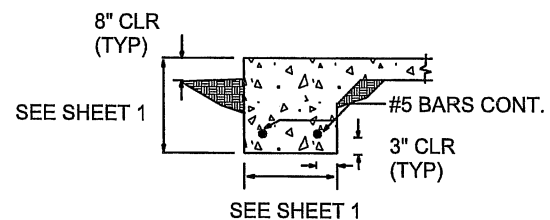

**THICKENED EDGE**

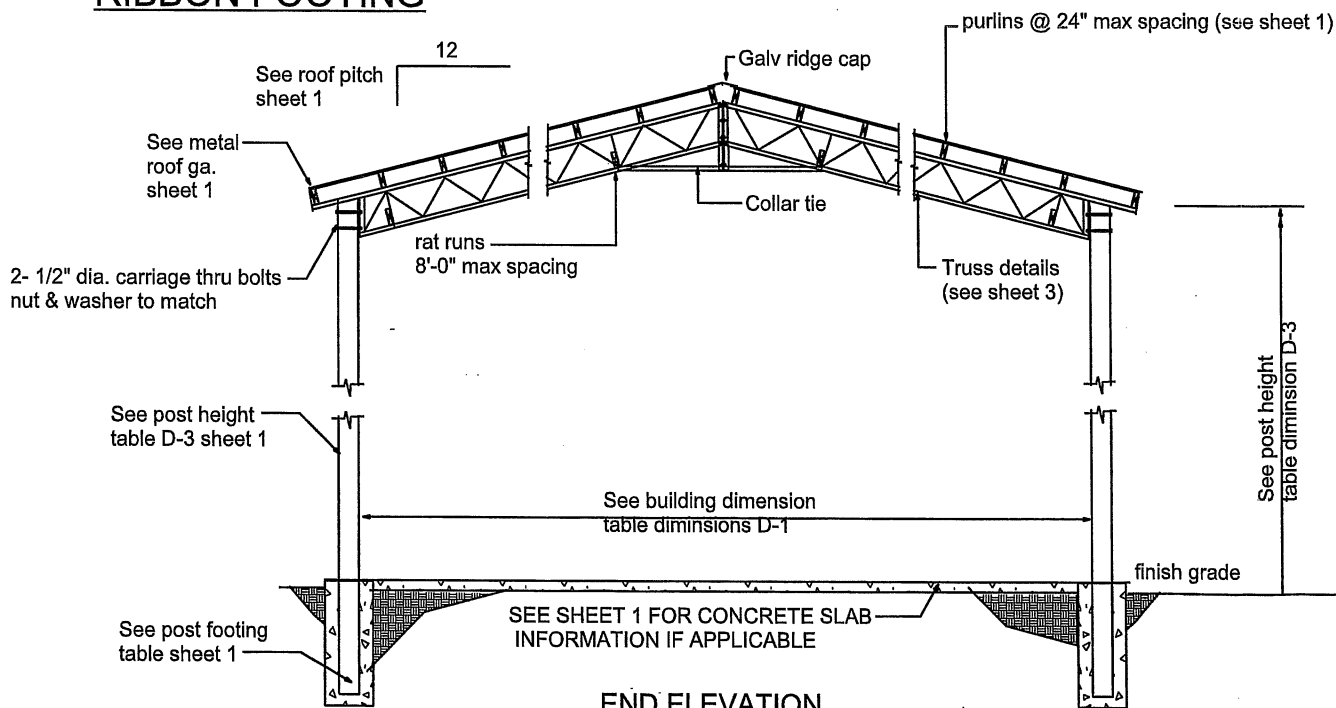

**END ELEVATION**  
NTS

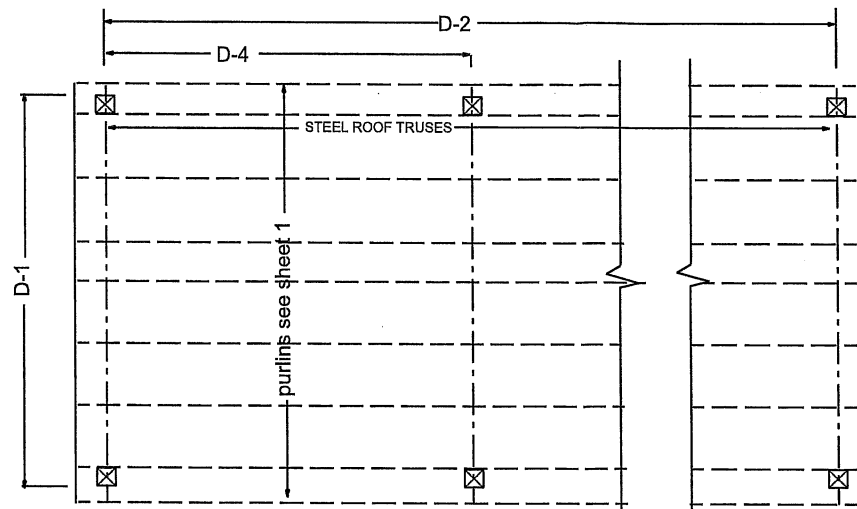

**PLAN VIEW POST SPACING**

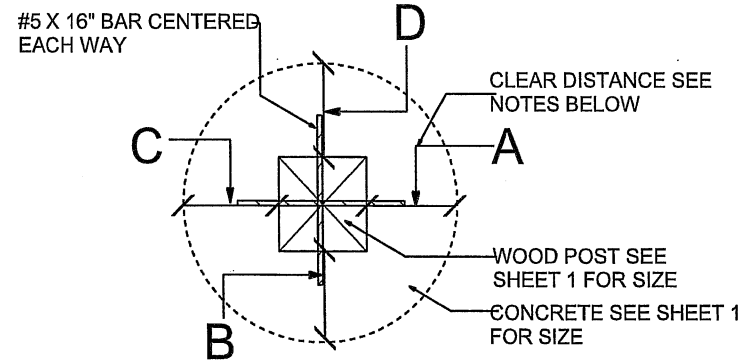

NOTES:

6" X 6" POST MIN CLEAR DISTANCE	A THRU D = 8"
8" X 8" POST MIN CLEAR DISTANCE	A THRU D = 7"
10" X 10" POST MIN CLEAR DISTANCE	A THRU D = 9"

**POST TO CONCRETE**  
**PLAN VIEW**

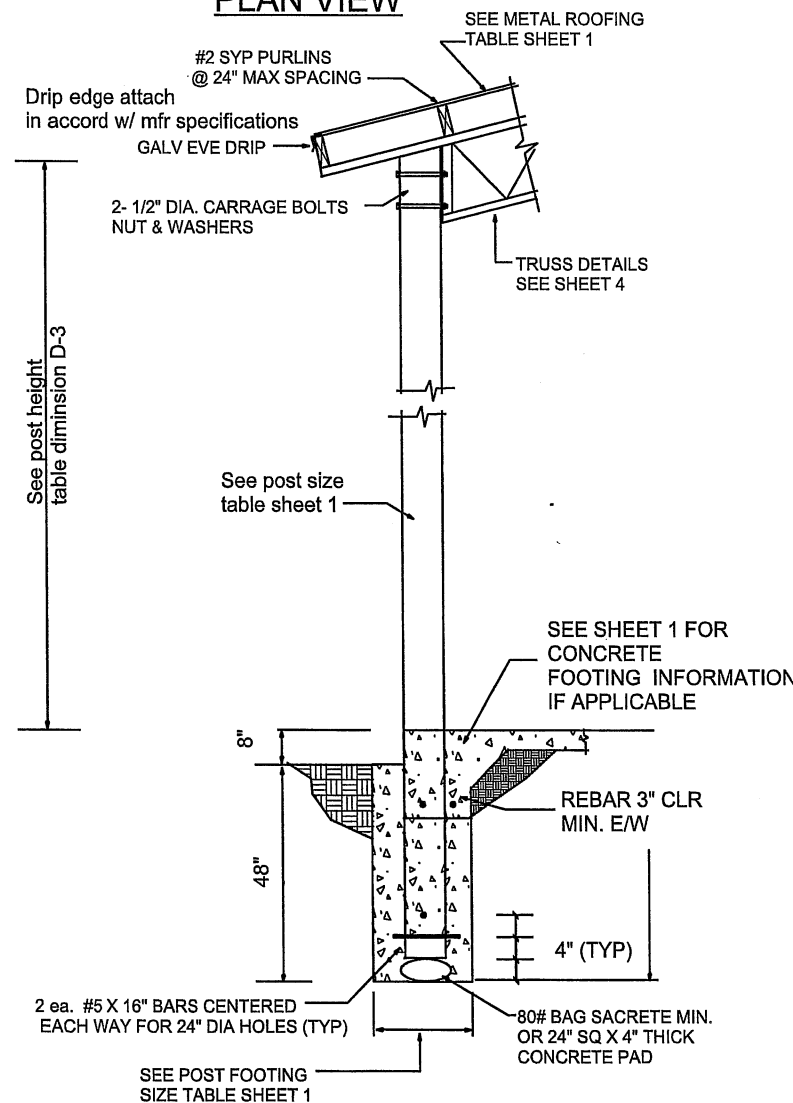

**POST FOOTING TO TRUSS DETAIL 1**

Michael E Driscoll PE  
FL Reg # 43922

SHEET: **2 OF 3**

THIS ITEM HAS BEEN ELECTRONICALLY SIGNED AND SEALED BY MICHAEL E. DRISCOLL, P.E. USING A SHA AUTHENTICATION CODE. PRINTED COPIES OF THIS DOCUMENT ARE NOT CONSIDERED SIGNED AND SEALED AND THE SHA AUTHENTICATION CODE MUST BE VERIFIED ON ANY ELECTRONIC COPIES ON 11-19-25

JAMES SMITH 11-19-25  
PARCEL # 0000000879000  
FORT WHITE, FL 32038  
DB25-821 40x60x16 DD

DRISCOLL ENGINEERING, INC.  
CONSULTING ENGINEERS  
P.O. BOX 375777  
GAINESVILLE, FL 32606  
PH (352) 331-1513 CA 8690  
FX (352) 505-3366

**STRUCTURAL ONLY**

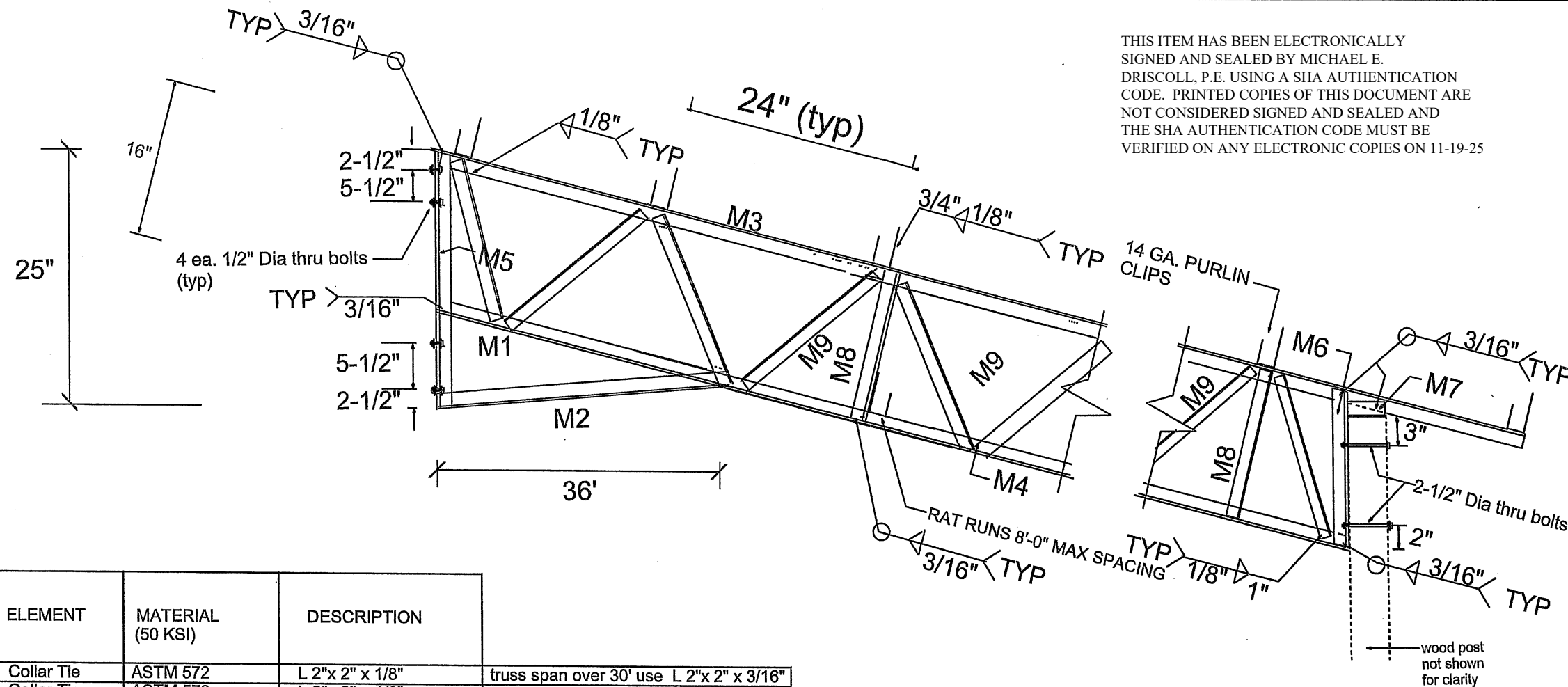

No.	ELEMENT	MATERIAL (50 KSI)	DESCRIPTION
M1	Collar Tie	ASTM 572	L 2"x 2" x 1/8"
M2	Collar Tie	ASTM 572	L 2"x 2" x 1/8"
M3	Top Chord	ASTM 572	L 2"x 2" x 1/8"
M4	Bottom Chord	ASTM 572	L 2"x 2" x 1/8"
M5	Center vertical	ASTM 572	L 2" x 2" x 3/16"
M6	End Vertical	ASTM 572	L 2" x 2" x 3/16"
M7	Bearing angle	ASTM 572	L 2" x 2" x 3/16"
M8	Inside vertical	ASTM 572	L 1-1/2" x 1-1/2" x 3/16"
M9	Diagonal web	ASTM 572	L 1-1/2" x 1-1/2" x 3/16"

\* truss span over 30' use L 2"x 2" x 3/16"  
 \* truss span over 30' use L 2"x 2" x 3/16"  
 \* truss span over 30' use L 2"x 2" x 3/16"  
 \* truss span over 30' use L 2"x 2" x 3/16"  
 \* truss span over 30' use L 3"x 2" x 3/8"  
 \* truss span over 30' use L 3"x 2" x 3/8"  
 \* (M8) 8'-0" o.c. max w/ rat runs

**NOTES:**

- 1-MATERIALS SHALL CONFORM TO STEEL ASTM 572.
- 2- ALL STEEL SHALL BE 50ksi IN ACCORD WITH CURRENT AISC MANUAL.
- 3- WELDING ELECTRODES TYPE E70XX
- 4- ALL WELDING SHALL BE IN ACCORD WITH CURRENT AWS REQUIREMENTS.
- 5-ALL WELDING SHALL BE DONE BY A CERTIFIED WELDER.
- 6-BOLTS SHALL BE ASTM A325. w/ NUTS & WASHERS. (TYP)
- 7- WELD STRENGTH 70 KSI MIN.
- 8- ALL POST SHALL PRESSURE TREATED GROUND CONTACT. (1500fb MIN.)
- 9- PRIMING & PAINTING SHALL BE DONE BY TRUSS MANUFACTURER.
- 10- MIN EDGE DISTANCE FOR BOLTS HOLES SHALL BE 3/4" MIN
- 11-MAX TRUSS SPACING SHALL NOT EXCEED 12'-0" UNO.
- 12-THE DESIGNER DISCLAIMS ANY RESPONSIBILITY FOR DAMAGES AS A RESULT OF POOR WORKMANSHIP, OR IMPROPER USE, AND ACCEPTS NO RESPONSIBILITY OR EXERCISES NO CONTROL WITH REGARD TO FABRICATION, HANDLING, AND INSTALLATION OF TRUSSES.

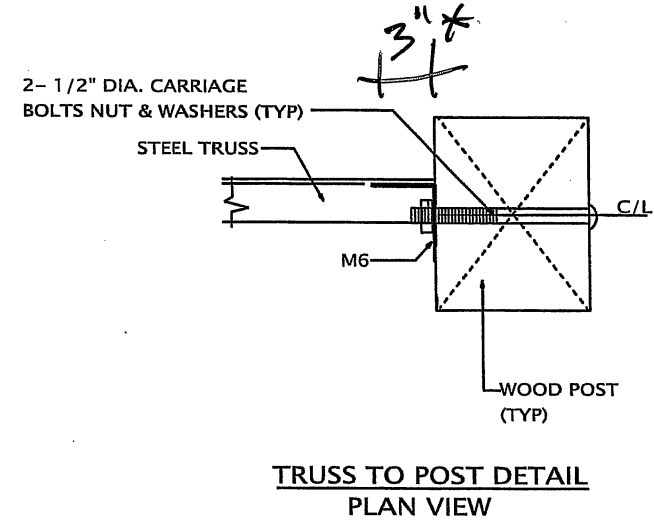

**TRUSS DETAILS**

STRUCTURAL ONLY Michael E. Driscoll, P.E.  
PE #43922

SHEET: 3 OF 3

JAMES SMITH 11-19-25  
 PARCEL # 0000000879000  
 FORT WHITE, FL 32038  
 DB25-821 40x60x16 DD

DRISCOLL ENGINEERING, INC.  
 CONSULTING ENGINEERS  
 PO BOX 357577  
 GAINESVILLE, FL 32606  
 CA 8680  
 PH (352) 331-1513  
 FX (352) 505-3566