

# Cool and Cobb Engineering Company

---

---

Date: 12/8/2023  
Job: Ferne Mann  
Location: 486 SW Memorial Dr., Ft. White, FL 32038

Project: 23-1456

## PUSH PIER DESIGN ANALYSIS

The load requirements for the pilings designed to assist in supporting the identified areas of the subject residence were determined. The selected piling locations and the specific piling are identified on the Pier Identification and Location Plan attached. The calculated total loads on the piles in the specific location, including both dead and live loads are documented in the attached table which is designated as Attachment "A". Based on the total load requirements for each of these piles, the push pier driver is to be employed. The push pier driver should be employed with a calculated load of 14,420 lbs., which will provide pile capacity, including the 2 to 1 safety factor of 28,840 lbs. which is greater than the maximum calculated total load of 14,420 lbs. which occurs on the pile identified as no. 1. Based on this analysis, the use of the push pier driver for the ECP piles with a specific load of 28,840 lbs. and a minimum depth of 15' is approved and certified as meeting all the requirements of the Florida Building Code 2020 7<sup>th</sup> Edition, and good engineering practice. This is not to be the primary support structure, but a supplement support to assist in support of the weight of the structure, which will reduce the total pressure on the existing soils. After completion of installation, Cool and Cobb Engineering Company shall be supplied with a drilling log of the location and depths of each pile installed so they can evaluate the installation and prepare the "As Built" drawings.

### General Notes:

1. All piers to be installed in accordance with ICC ES AC 358
2. A log of each pier to be kept by Contractor noting depth for each pile.
3. Piers installed less than 48" apart are to be battered 10° away from each other.
4. All pile calculations are based on a maximum spacing of 8'-0".
5. This design is based on the loads of the structure placed on the shallow soils under the structure.
6. No deep soils geotechnical testing information was provided for this design.
7. This design does not address any possible sink hole activity as defined in Florida Statute § 627.706.

12/8/2023  
Carl Cool, P.E.  
State of Florida  
Professional Engineer No. 16921



Digitally  
signed by Carl  
E Cool  
Date:  
2023.12.08  
11:22:56 -05'00'

This Item has been electronically sealed by Carl Cool using a digital signature and date. Printed copies of this document are not considered signed and sealed and the signature must be verified on any electronic copies.

203 W. Main St.  
Avon Park, FL 33825  
Office: (863) 657-2323  
Fax: (863) 657-2324

# Cool and Cobb Engineering Company

---

---

Date: 12/8/2023  
Job: Ferne Mann  
Location: 486 SW Memorial Dr., Ft. White, FL 32038

Project: 23-1456

## POLY INJECTION DESIGN ANALYSIS

The load requirements for the structural polyurethane injections designed to level the identified areas of the subject residence were determined. The selected injection locations and the specific injection are identified on the Injection Identification and Location Plan attached. The design of the injected Polyurethane is certified as meeting all of the requirements of the Florida Building Code 2020 7<sup>th</sup> Edition, and good engineering practice. This will be the primary support of the structure, which will not change the pressure on the existing soils. After completion of installation, Cool and Cobb Engineering Company shall be supplied with a log of the location and depths of each injection installed along with post injection floor level readings for evaluating the installation and prepare the "As Built" drawings.

### **General Notes:**

1. Assume load of 90 lbs / ft<sup>2</sup> .
2. All injections to be installed in accordance with ICC ES AC 358
3. A log of each injection to be kept by Contractor noting depth installed for each injection and the corrected level readings.
4. This design is based on the loads of the structure placed on the shallow soils under the structure.
5. No deep soils geotechnical testing information was provided for this design.
6. This design does not address any possible sink hole activity as defined in Florida Statute § 627.706.

12/8/2023

Carl Cool, P.E.  
State of Florida  
Professional Engineer No. 16921





Digitally signed  
by Carl E Cool  
Date:  
2023.12.08  
11:23:44 -05'00'

This Item has been electronically sealed by Carl Cool using a digital signature and date. Printed copies of this document are not considered signed and sealed and the signature must be verified on any electronic copies.

203 W. Main St.  
Avon Park, FL 33825  
Office: (863) 657-2323  
Fax: (863) 657-2324

**Legend**

- Foundation 
- Exterior Pier 
- Poly Foam 



Digitally signed by  
 Carl E Cool  
 Date: 2023.12.08  
 11:24:14 -05'00'

12/8/2023  
 Carl E. Cool, P.E.  
 P.E. # 16921  
 Cool and Cobb Engineering Co.  
 203 W. Main St.  
 Avon Park, FL 33825

This item has been electronically sealed by Carl E. Cool using a digital signature and date. Printed copies if this document are not considered signed and sealed and the signature must be verified on any electronic copies.

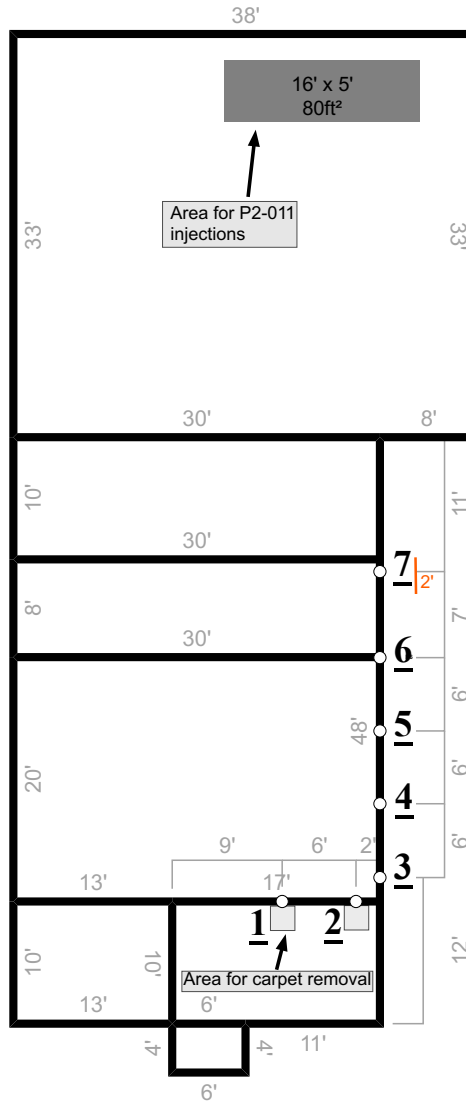

Concrete block structure  
 Built: 1954  
 Foundation: Concrete slab  
 Slab depth: 10"  
 Siding: Concrete block  
 Roof: Metal

FPI to install (7) ECP  
 250 Concentric Push  
 Piers along foundation  
 for support

**Mann - Foundation Repair**

**Foundation Professionals of Florida**  
 3309 SW State Road 247  
 Lake City, FL 32024  
 www.foundationprosfl.com

**Project Address**  
 Ferne Mann  
 486 SW Memorial Dr  
 Fort White, FL 32038

**Created By**  
 Conner Rawlins  
 (904) 515-8680  
 11/21/2023



# Cool and Cobb Engineering Company

---

---

Date: 12/8/2023  
Job: Ferne Mann  
Location: 486 SW Memorial Dr., Ft. White, FL 32038  
Project: 23-1456

## Attachment "A"

PILE NO.	Total Load on Pile	(Live Load + Dead Load)	
		TOTAL CALCULATE LOAD	
1		14,420	lbs
2		10,300	lbs
3		7,440	lbs
4		8,640	lbs
5		7,200	lbs
6		14,400	lbs
7		13,360	lbs

Maximum Total Load on Pile: 14,420 lbs



Digitally signed  
by Carl E Cool  
Date:  
2023.12.08  
11:24:41 -05'00'

This item has been electronically sealed by Carl E. Cool using a digital signature and date. Printed copies if this document are not considered signed and sealed and the signature must be verified on any electronic copies.

12/8/2023  
Carl E. Cool, P.E.  
PE# 16921

Cool and Cobb Engineering Co.  
203 W. Main St.  
Avon Park, FL 33825

## ECP Steel Pier™ -- PPB-200 & PPB-250 Under Footing Bracket Pier System

- |                                                                                                                                                                                 |                                                                                                                                                                                  |
|---------------------------------------------------------------------------------------------------------------------------------------------------------------------------------|----------------------------------------------------------------------------------------------------------------------------------------------------------------------------------|
| <ul style="list-style-type: none"> <li>• PPB-200 Ultimate Capacity – 50,000 lb</li> <li>• Maximum Proof Load – 37,500 lb</li> <li>• 68 Square Inches Bearing Surface</li> </ul> | <ul style="list-style-type: none"> <li>• PPB-250 Ultimate Capacity – 54,000 lb</li> <li>• Maximum Proof Load – 40,500 lb</li> <li>• 100 Square Inches Bearing Surface</li> </ul> |
|---------------------------------------------------------------------------------------------------------------------------------------------------------------------------------|----------------------------------------------------------------------------------------------------------------------------------------------------------------------------------|
- 
- |                                                                                                                                                                                                                                                                                            |                                                                                                                                                                                                                                                                                            |
|--------------------------------------------------------------------------------------------------------------------------------------------------------------------------------------------------------------------------------------------------------------------------------------------|--------------------------------------------------------------------------------------------------------------------------------------------------------------------------------------------------------------------------------------------------------------------------------------------|
| <ul style="list-style-type: none"> <li>• Standard Lift – 4”</li> <li>• Fully Adjustable Unlimited Lift Capability</li> <li>• Installs Under Footing</li> <li>• Friction Reduction Collar On Lead Pier Section</li> <li>• 2-7/8” Diameter High Strength, Galvanized Tubular Pier</li> </ul> | <ul style="list-style-type: none"> <li>• Installs With Portable Equipment</li> <li>• Installed With Little or No Vibration</li> <li>• Installs To Rock or Verified Load Bearing Stratum</li> <li>• 100% of Piers Proof Tested When Installed</li> <li>• Manufacturer’s Warranty</li> </ul> |
|--------------------------------------------------------------------------------------------------------------------------------------------------------------------------------------------------------------------------------------------------------------------------------------------|--------------------------------------------------------------------------------------------------------------------------------------------------------------------------------------------------------------------------------------------------------------------------------------------|



Digitally signed  
 by Carl E Cool  
 Date: 2023.12.08  
 11:25:22 -05'00'

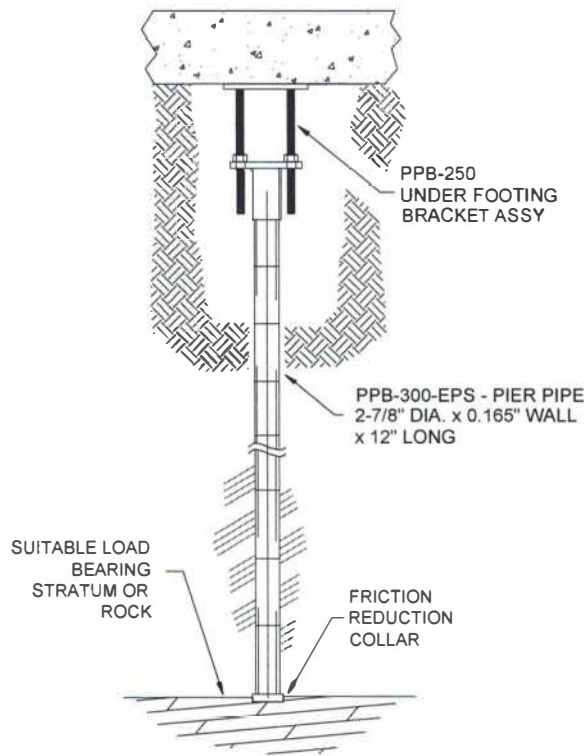
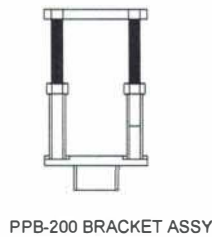

### PPB-200 & PPB-250 Under Footing Bracket Details

### PPB-250 Under Footing Pier System Application Details

The capacity of the PPB-200 and PPB-250 under foundation support system is a function of the capacity of pier pipe and soil surrounding the pipe, capacity of the load bearing stratum, capacity of the foundation bracket, foundation strength and strength of the bracket to foundation connection. Actual capacities could be lower than the bracket capacity.

*Earth Contact Products, LLC reserves the right to change design features, specifications and products without notice, consistent with our efforts toward continuous product improvement. Please check with Earth Contact Products at 972 480-0007 or 913 393-0007 to verify that you are using the most recent specifications.*

## PPB-250--Concentric Bracket

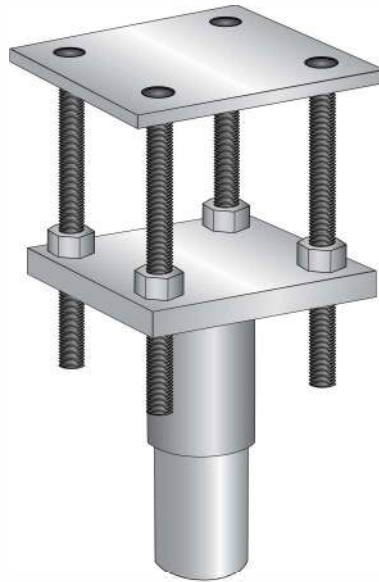

12/8/2023  
Carl E. Cool, P.E.  
P.E. # 16921  
Cool and Cobb Engineering Co.  
203 W. Main St.  
Avon Park, FL 33825



Digitally signed  
by Carl E Cool  
Date: 2023.12.08  
11:26:18 -05'00'

### Product Specifications

Anchor Style	Concentric Pier
Component	Pier Bracket
Capacity	54 Kip
Bearing Surface	100 square inches
Lift Capacity	Fully Adjustable for Unlimited Lift
Coating	Black
Standard Package	40
Standard Package Unit	Each Bracket w/ starter section
Weight	62 lbs.
Min Order Qty	1

### Notes

Concentric Bracket



Digitally signed  
 by Carl E Cool  
 Date: 2023.12.08  
 11:26:51 -05'00'

## P2-011 Rigid Foam System

### Technical Data Sheet

P2-011 is a two-component, HFC 245fa blown, all PMDI-based, pour-in -place urethane foam system designed for concrete jacking and cavity filling in wet environments. P2-011 has low component viscosities making the system suitable for mechanical mix machines, high pressure (over 600 psi) impingement mixing machines or hand mixing.

### Typical Properties of Components

Component	P2-011	A2-000
Appearance	clear amber liquid	clear brown liquid
Brookfield Viscosity @ 20 rpm	550 cps at 72°F	200 cps at 72°F
Specific Gravity	1.08	1.24
Weight per Gallon, lbs	8.9	10.3
Storage Temperature	60°F - 90°F	60°F- 90°F

### Mix Ratio

By weight.....100 parts poly : 116 parts iso  
 By volume.....100 parts poly : 100 parts iso

### Typical Properties of Machine-Mixed System at 120°F

Cream Time	7 seconds
Tack Free Time	14 seconds
Free Rise Core Density	4.5 pcf

### Typical Processing Parameters\*

Iso Temperature	110°F to 140°F
Poly Temperature	110°F to 140°F
Mixing Pressures	1000 psi static, 800 psi dynamic

\* Using standard spray equipment with 1/1 by volume proportioning pumps capable of maintaining 800-1200 psi dynamic pressures. The Graco Reactor E20-series or better with a GX-7 gun is preferred equipment. P2-011 **B** is connected to the **resin/polyol** pump with the A2-000 being connected to the **isocyanate** pump.



Digitally signed  
by Carl E Cool  
Date: 2023.12.08  
11:27:19 -05'00'

12/8/2023  
Carl E. Cool, P.E.  
P.E. # 16921  
Cool and Cobb Engineering Co.  
203 W. Main St.  
Avon Park, FL 33825

**Typical Physical Properties:**

		Free Rise Hand Mix	Restrained Rise
Density, pcf	ASTM D 1622	4.8	6.5
Compressive Strength, psi	ASTM D 1621	110	120
Tensile Strength, psi	ASTM D 1623	130	140
Shear Strength, psi	ASTM C 273	70	85
Flexural Strength, psi	ASTM D-790	140	160
Closed Cell Content, %	NCFITM 300	> 94	> 94
Water Absorption, lbs./ft <sup>2</sup>	ASTM D 2842	≤ 0.04	≤ 0.04
Resistance to Solvents		Excellent	
Resistance to Mold and Mildew		Excellent	
Maximum Service Temperature		200° F	

**Storage and Handling**

Store the poly from 50°F to 90°F. Avoid moisture contamination during storage, handling, and processing. For both components, pad containers and day tanks with either nitrogen or dry air (desiccant cartridge or air dryer @ -40°F dew point). For optimum shelf life, the recommended storage temperature for iso is 50°F to 90°F. **Do not expose iso to lower temperatures – freezing may occur.** Store components at 70° F to 90° F for several days prior to use to minimize components being too viscous at time to take to field. Shelf life is 6 months for factory sealed containers.

Original: 122817