



FRONT OF HOUSE

Inverter Type: (36) Enphase IQ8A-72-2-US  
 PV Panel: (36) Sunpal SP460M-72HB  
 Racking: Iron Ridge XR-10  
 Total Wattage: 16,560W DC  
 Roof Type: Composition Shingle  
 Wind Load: 8 to 20 Deg  
 Fastener Type: Use Unirac Flashloc Duo

**Sheet Index**

- S-1 Cover Sheet / Site Plan
- S-2 Detail
- E-1 One - Line
- E-2 Electrical Code
- S-1A Mounting Plan

**General Notes:**

- Enphase IQ8A-72-2-US Micro Inverters are located on roof behind each module.
- First responder access maintained and from adjacent roof.
- Wire run from array to connection is 40 feet.

933 Clint Moore Rd  
 Boca Raton, FL 33487  
 800-530-9597

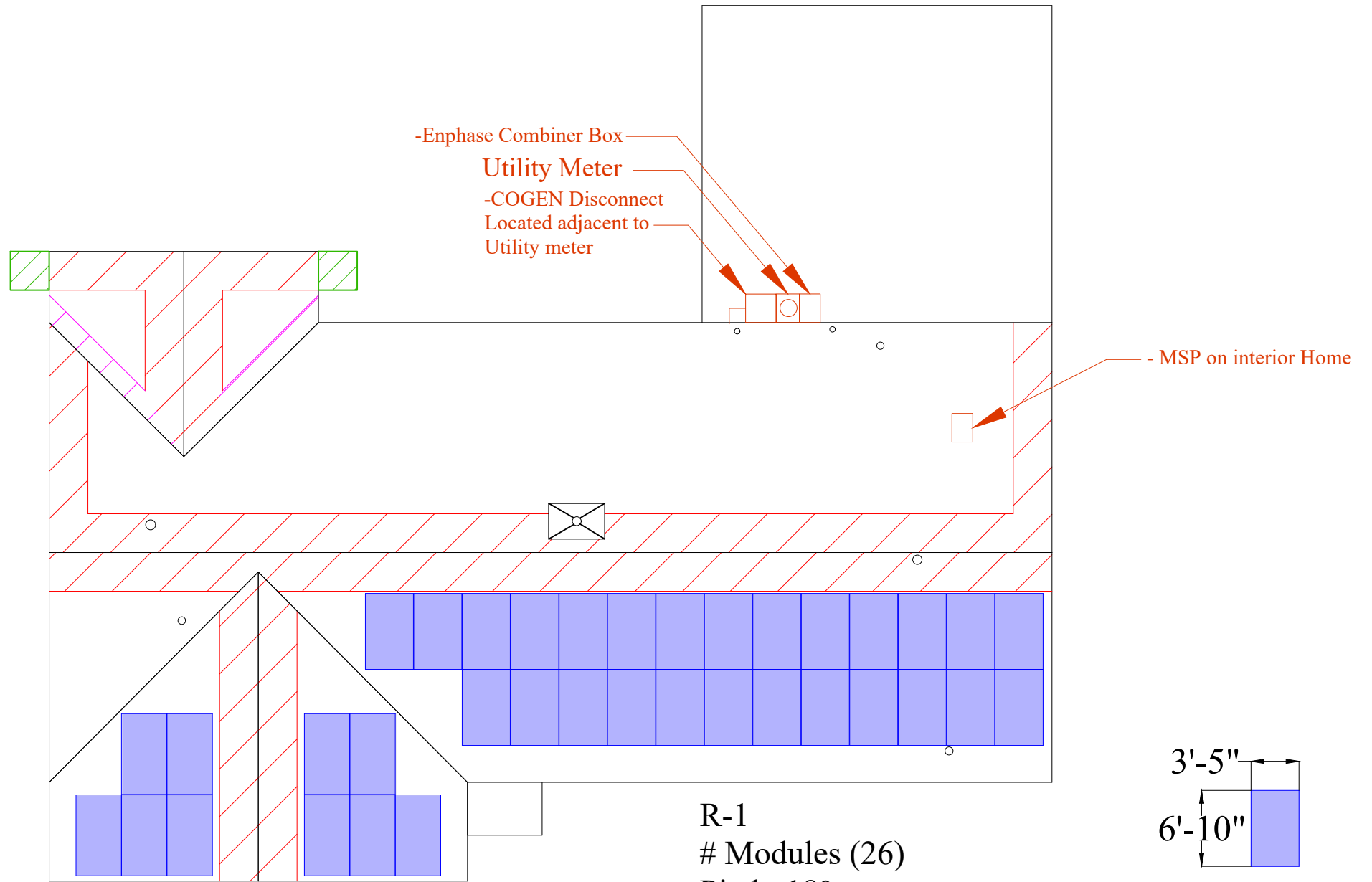

R-3  
 # Modules (5)  
 Pitch: 18°  
 Azimuth: 270

R-2  
 # Modules (5)  
 Pitch: 18°  
 Azimuth: 90°

R-1  
 # Modules (26)  
 Pitch: 18°  
 Azimuth: 180°

Layout Subject to Change Based on Site Conditions

System meets the requirements of NFPA 70th Edition, Chapter 1:11.12 (2018 Edition)

Install will be done to Manufacturer Spec

**Legend**

- Ground Access
- First responder access
- Utility Meter
- PV Disconnect
- Chimney
- Satellite
- Vent Pipe

Meets All Editions of Florida Fire Prevention Code 2020 7th Edition  
 Meets all requirements of 2018 Editions of NFPA-1 and NFPA-101

3' Access Pathway

Represents all Fire Clearance including Alternative methods

1st Responder Access minimum of 36" unobstructed as per Section R324 of the 2020 IRC

**Customer Info:**

Jean and Garry Sparkman  
 311 SE Oak St  
 Lake City, FL  
 32025

Godwin Engineering and Design, LLC  
 8378 Foxtail Loop  
 Pensacola, FL 32526  
 D. Chad Godwin, PE  
 Chad@godwineng.com

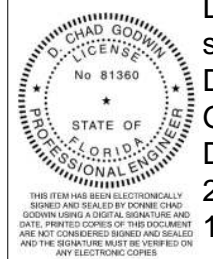

Digitally signed by Donnie Godwin  
 Date: 2022.08.24 12:35:30 -05'00'

**Date:** 8/19/2022  
**Drawn by:** SK  
**Revised by:**  
**Rev #:** 00  
**Rev Date:**  
**Page:** 11"x17" S-1

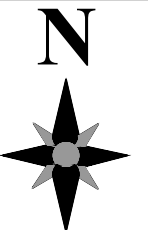

Compass for Aerial

Meets the requirements of the following- (2020 FL Residential Code & FBC, 7th Edition (2020 International Residential Code) - 2nd Printing modified by the FL Building Standards, 2020 Florida Building Energy Conservation Code 7th edition, County of Columbia Code, 2017 National Electric Code.)

FRONT OF HOUSE



Ironridge XR-10



Unirac Flashloc Duo

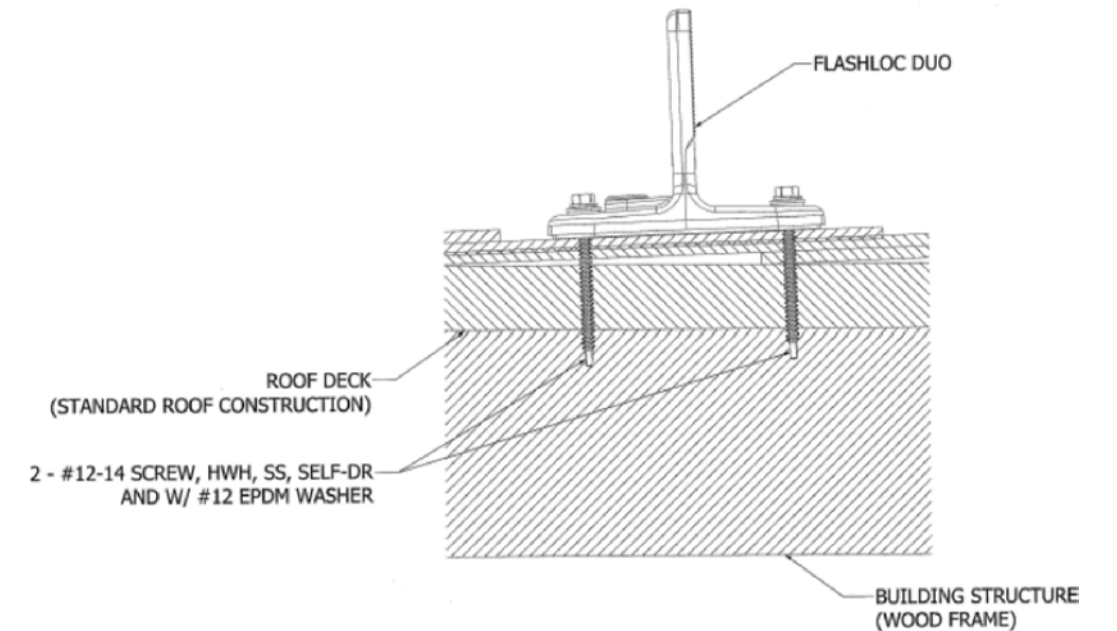

**General Notes:**

- L Feet are secured to roof rafters.  
@ 48" O.C. in Zone 1, @ 48" O.C in Zone 2e, @ 24" O.C. in Zone 2n,  
@ 24" O.C. in Zone 2r, @ 24" O.C in Zone 3e, & @ 24" O.C. in Zone 3r  
using (2) #12-14 x 2.5" Self-drilling Screws.
- Subject roof has One layer.
- Penetrations will be sealed with M1 Chemlink and flashed
- M1 Chemlink in compliance with ASTM C920

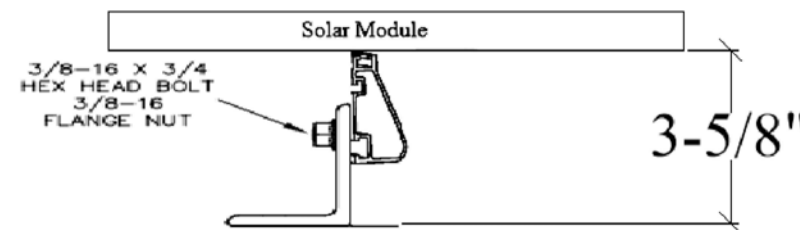

Install will be done to Manufacturer Spec

Godwin Engineering and Design, LLC  
8378 Foxtail Loop  
Pensacola, FL 32526  
D. Chad Godwin, PE  
Chad@godwineng.com

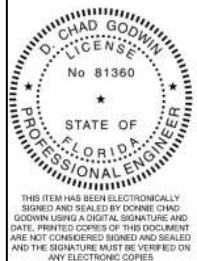

Digitally signed by Donnie Godwin  
Date: 2022.08.24 12:35:38 -05'00'

Roof Section	Pitch	Roof Rafter and Spacing	Overhang	Notes:
R1-R3	4/12	2"x4" @ 24 O.C.	12"	Truss

**-Roof Height 15'**  
**-Per 2020 FBC, the Roof Mounted PV System will be subject to the following design criteria:**  
**Design Wind Speed(Vult) - 120mph 3 sec gust,**  
**Exposure Category - C**  
**-Designed as per ASCE7-16**

Inverter Type: (36)Enphase IQ8A-72-2-US  
 PV Panel: (36) Sunpal SP460M-72HB  
 Racking: Iron Ridge XR-10  
 Total Wattage: 16,560W DC  
 Roof Type: Composition Shingle  
 Wind Load: 8 to 20 Deg  
 Fastener Type: Use Unirac Flashloc Duo

**Customer Info:**  
  
 Jean and Garry Sparkman  
 311 SE Oak St  
 Lake City, FL  
 32025

**GO SOLAR POWER™**

933 Clint Moore Rd  
 Boca Raton, FL 33487  
 800-530-9597

<b>Date:</b>	8/19/2022
<b>Drawn by:</b>	SK
<b>Revised by:</b>	.
<b>Rev #:</b>	00
<b>Rev Date:</b>	.
<b>Page:</b>	11"X17" S-2

12-2 Romex can be used for interior building and attic runs only. Do not use romex in conduit or outdoor environments.

#10 AWG THWN for Home runs  
 (1) Line 1  
 (1) Line 2  
 Per Circuit  
 (1) EGC  
 Inside @ least 3/4" Conduit (tbd on site)

Enphase IQ Trunk Cable  
 Q-12-240  
 #12AWG THHN-THWN-2  
 UL 9703

Photovoltaics:  
 (36) Sunpal SP460M-72HB  
 Inverters:  
 (36) Enphase IQ8A-72-2-US Micro Inverters  
 Circuits:  
 (4) circuits of (9) Modules  
 Maximum Inverters Per 20A Circuit (11)

Grounding Conductor to be protected  
 #8 Awg or to be unprotected #6 Awg  
 250.64(B) 250.66 & 250.120(C)

Roof

NEMA 3R  
 Junction Box  
 Black - L1  
 Red - L2  
 Green - Ground

WARNING  
 ELECTRIC SHOCK HAZARD  
 DO NOT TOUCH TERMINALS.  
 TERMINALS ON BOTH THE LINE AND  
 LOAD SIDES MAY BE ENERGIZED IN  
 THE OPEN POSITION

PHOTOVOLTAIC SYSTEM  
 ! AC DISCONNECT !  
 RATED AC OUTPUT CURRENT: 52.2A  
 NOMINAL OPERATING VOLTAGE: 240VAC

Main Service Panel  
 200A Main

Line Side Tap

Manual Lockable Disconnect  
 100A Service Rated  
 Fused Disconnect  
 Neutral to Ground Bond  
 AC Disconnect  
 70A Fuse

Located Adjacent to Utility Meter

In Compliance with  
 NEC 705.12(B)

Enphase Combiner Box  
 (1) - 20A Breaker  
 Per Circuit  
 4 Circuits  
 240V  
 10/15A Breaker for Envoy  
 Disconnect  
 Solar Combiner Box  
 #X-IQ-AM1-240

B

C

		Conduit (in)	L1,L2,N (Awg)	Ground (Awg)	OCPD
After Combiner	B	1	4	8	70
To Line Side Tap	C	1	4	N/A	70

- NEC LABEL NOTES:
1. THE WARNING SIGN(S) OR LABEL(S) SHALL COMPLY WITH NEC 110.21(B)
  2. LABELS SHALL BE SUITABLE FOR THE ENVIRONMENT WHERE THEY ARE INSTALLED.
  3. LABELS TO BE A MIN LETTER HEIGHT OF 3/8" AND PERMANENTLY AFFIXED.
  4. LABELS SHALL ALSO COMPLY WITH THE SPECIFIC REQUIREMENTS OF THE AUTHORITY HAVING JURISDICTION.

Refer to NEC 312.8 for Conditions on taps in switch and over current devices Enclosures. If the conditions are not met a tap box will need to be installed and revision completed.

Enphase Output Ckt Per String	
To Overcurrent Protection Device	
AC Max Output Current	13.05
AC Max Output Current * 1.25%	16.3
Overcurrent Protection (A)	20
No. of Current Carrying Cond	<4
Conductor Gauge (AWG)	10
Enphase Total Output Ckt	
AC Max Output Current	52.2
AC Max Output Current * 125%	65.3
Overcurrent Protection (A)	70
No. of Current Carrying Cond	<4
Conductor Gauge (AWG)	4

Godwin Engineering and Design, LLC  
 8378 Foxtail Loop  
 Pensacola, FL 32526  
 D. Chad Godwin, PE  
 Chad@godwineng.com



Digitally signed by Donnie Godwin  
 Date: 2022.08.24 12:35:49 -05'00'



933 Clint Moore Rd  
 Boca Raton, FL 33487  
 800-530-9597

Including the label below  
 In Case of Emergency Call  
 Go Solar Power  
 at 800-530-9597  
 EC 13007879 CVC56962

Meets 11.12.2.1.5

Note:  
 -All wiring to meet the 2017 NEC and Florida electric codes.  
 100A Disconnect  
 -Type of conduit to be determined on site by contractor.

Install will be done to Manufacturer Spec

GEC NOTES  
 - Ungrounded system per 690.41(A)(4)  
 - GEC must be installed per 250.64  
 - GEC must be continuous un-spliced or irreversibly spliced from inverter to existing service ground system or continuous from the arrays to the existing service ground system.  
 - GEC must be min #8 AWG and installed in conduit  
 - If GEC is not in conduit, it must be #6 min  
 Disconnects will be Visible, lockable, adjacent to and within 10' of utility meter  
 All Labels & Markings for photovoltaic system will be reflective and meet all requirements for NFPA 11.12

Customer Info:  
 Jean and Garry Sparkman  
 311 SE Oak St  
 Lake City, FL  
 32025

Date:	8/19/2022
Drawn by:	SK
Revised by:	.
Rev #: 00	
Rev Date:	.
Page:	11"x17" E-1

Inverter Type:  
 Enphase IQ8A-72-2-US  
 PV Panel:  
 (36)  
 Sunpal SP460M-72HB  
 Total Wattage:  
 16,560W DC

System meets the grounding requirements of NEC 690.43

The Placard shall be permanently riveted..., and shall be made of red, weatherproof, hard plastic, with engraved white block lettering.

**Rapid Shutdown Built in Per Code NEC 690.12**

**PV AC disconnect is lockable in the open position per code NEC 705.22(7)**

-A placard will be added with instructions and locations to be in compliance with 690.12, 690.56(B) and NEC 705.10

In compliance with NEC 250.58, NEC 690.8, NEC 250.24, NEC250.24(D)

Conductors have a min ampacity of 60 amperes Per Code NEC 230.79(D)

Inverter Output Ckt To Overcurrent Protection Device		
Design Temperature(F)	94°F	
Max Amb Temp Range(F)	87-95	310.15(B)(2)(a)
Temp Rating of Conductors (C)	75°C	
Current Carrying	<4	310.15(B)(3)(a)
AC Max Output Current	52A	690.8(A)(3)
AC Max Output Current * 1.25%	65A	690.8(B)
Overcurrent Protection(A)	70A	
Amp Temp Correction Factor	0.94	310.15(B)(2)(a)
Raceway Fill adjustment Factor	100%	310.15(B)(3)(a)
Wire Size (Awg)	4	310.15(B)(16)
Cond. Allowable Ampacity(A)	85A	
Cond Adjusted Ampacity(A)	80A	85A*1*0.94=79.9A
Ampacity Check 1 Per 690.8(B)(1)	Pass	52.2A*1.25=70A<85A Pass
Ampacity Check 2 Per 690.8(B)(2)	Pass	85A*0.94A*1=79.9A>52.2A Pass

Everything will be built to Code without all Specifics labeled on plan

System is in compliance with FFPC 1:11.12 7th Edition.

Smoke Detectors will be added as per FBC 553.883

Markings shall be placed on all DC Conduits, DC Combiners, Raceways, Enclosures, Junction Boxes, and Cable Assemblies at every 10', turns, and above and below penetrations in compliance with NFPA

All Exterior equipment is A minimum of Nema-R3 Rated

All Interactive System(S) Points of interconnection with other sources shall be marked at an accesible location at the disconnecting means as a power source and with the rated ac output current and the nominal operating AC voltage. Per NEC 690.54

In compliance with 230.71

Combiner box in compliance Per Code NEC 705.12

4\* 20A < 125A

\*No other loads to be added

Disconnect means shall be provided for all disconnecting all ungrounded conductors that supply or pass through the building or structure Per Code 2017 NEC Section 225.31 & Section 225.32

Disconnect is in compliance 230.72

Supply side disconnect adjacent to Msp

In Case of Emergency Call Go Solar Power at 800-530-9597 EC 13007879 CVC56962

Apply to Main Disconnect

Permanent sticker added to disconnect

E04. Construction documents specify PV system circuits installed on or in buildings include a rapid shutdown function that controls specific conductors in accordance with NEC article 690.12.

E05. These construction documents specify that a label is provided with the method to initiate rapid shut down per 690.12(4).

E06. Construction drawings specify buildings or structures with both utility service and a PV system, complying with NEC article 690.12 shall have a permanent plaque or directory including the following wording: "PHOTO VOLTAIC SYSTEM EQUIPPED WITH RAPID SHUTDOWN" as per NEC article 690.56 (C).

E07. Construction documents specify PV power circuit labels shall appear on every section of the wiring system that is separated by enclosures, walls, partitions, ceilings, or floors.

E08. Construction documents specify all warning sign(s) or label(s) shall comply with NEC article 110.21 (B). Label warnings shall adequately warn of the hazard. Labels shall be permanently affixed to the equipment, and Labels required shall be suitable for the environment.

Over Current Protection Device is "Next size up" Based on Inverter Maximum Continuous Output Current Rating 2017 NEC 240.4(B)

-All new equipment located adjacent to Meter on exterior wall

Labels will be placed in the correct location Per Code NEC 690.56(B), 690.56(C), & 690.53

Smoke Alarms per F.S. 553.883

Include required label for metallic raceways and conduits to sheet E-1 per NEC article 690.31(G)(3).

Add required label to sheet E-1 per NEC article 705.10.

Include required label to sheet E-1 per NEC article 705.12(B)

Photovoltaic AC disconnect shall be capable of being locked in the open position per NEC article 705.22(6).

Photovoltaic AC Overcurrent protection shall be located within 10 feet of the point where conductors are connected to the service per NEC 705.31.

-All Electrical Service Equipment shall be located at or above BFE+1' or 8.00' NAVD

Line Side Tap will be done in Main Service Panel Located Inside the Home.

-Markings Shall Be reflective, Weather Resistant and suitable for the environment. -Markings Shall be red with white lettering with minimum 3/8" Capital Letters

Note: -Subject PV Systems has been designed to meet the requirments of the NEC 2017, and those set forth by the Florida Solar Energy Center Certification, Including Maximum Number of Module Strings, Maximum number of modules per string, Maximum Output, Module Manufacturer and model number, inverter manufacturer and model number, as applicable.

NEC 705.10 A permanent plaque or directory, denoting the location of all electric power source disconnecting means on or in the premises, shall be installed at each service equipment location and at the location(s) of the system disconnect(s) for all electric power production sources capable of being interconnected. One sign required for each PV system.

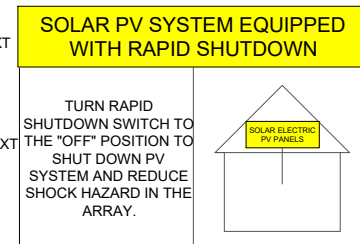
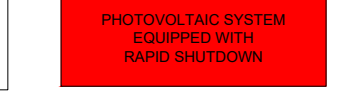
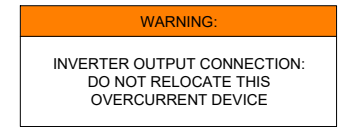
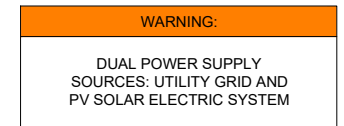
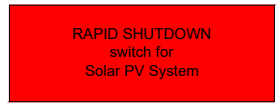

Figure 690.56(C)(1)(a) Label for PV Systems that Shut down the array and the conductors leaving the array

Godwin Engineering and Design, LLC  
8378 Foxtail Loop  
Pensacola, FL 32526  
D. Chad Godwin, PE  
Chad@godwineng.com

Digitally signed by Donnie Godwin  
Date: 2022.08.24 12:35:57 -05'00'

**SOLAR POWER**

933 Clint Moore Rd  
Boca Raton, FL 33487  
800-530-9597

Date:	8/19/2022	Inverter Type: Enphase IQ8A-72-2-US PV Panel: (36) Sunpal SP460M-72HB Total Wattage: 16,560W DC
Drawn by:	SK	
Revised by:	.	
Rev #: 00		
Rev Date:	.	
Page:	11"x17" E-2	

Plans Satisfy NEC 250.94 & NEC250.53(A)(2)

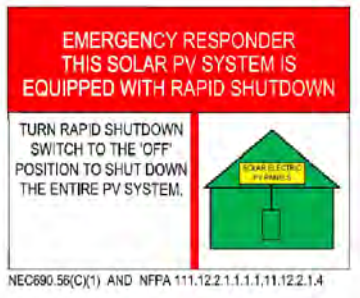

Install will be done to Manufacturer Spec

Including the label below

In Case of Emergency Call Go Solar Power at 800-530-9597 EC 13007879 CVC56962

Customer Info:

Jean and Garry Sparkman  
311 SE Oak St  
Lake City, FL 32025

**Proposed Mounting locations**

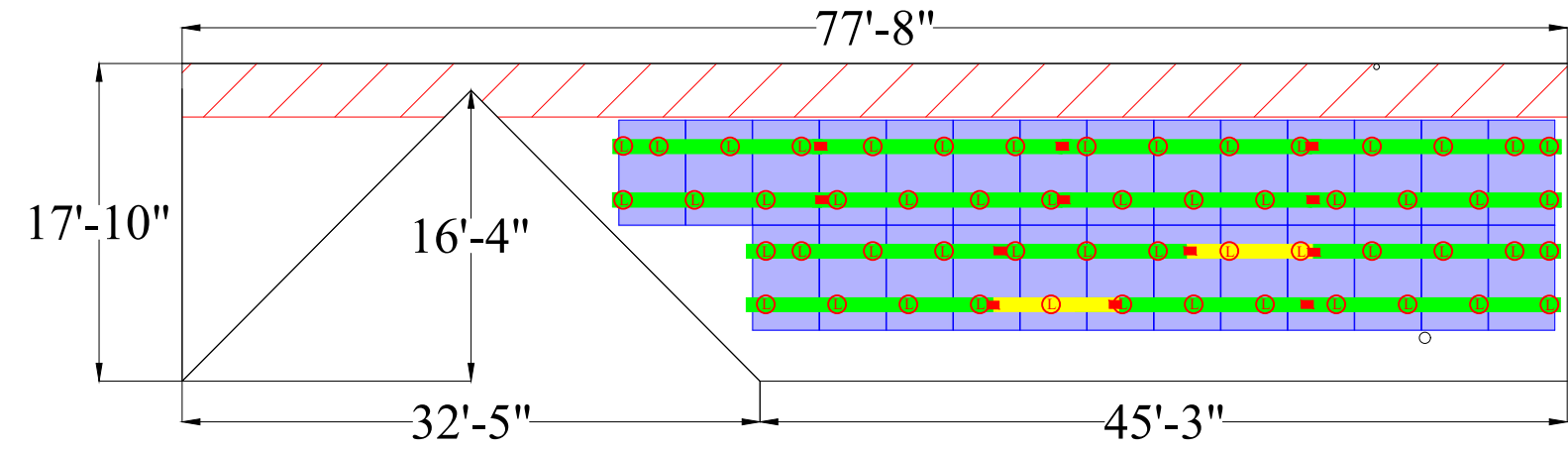

- Iron Ridge XR-10 Rail
- 14'
- 7'
- 4'
- Splice Bar
- Unirac Flashloc Duo
- Iron Ridge UFO's
- Iron Ridge Sleeves/End Caps
- Roof Top Combiner
- Iron Ridge Ground Lugs
- Sunpal SP460M-72HB
- Enphase IQ8A-72-2-US
- 100A Fused Disconnect
- 70A Fuses
- 20A 2P Breaker
- Enphase Combiner Box

R-1  
# Modules (26)  
Pitch: 18°  
Azimuth: 180°

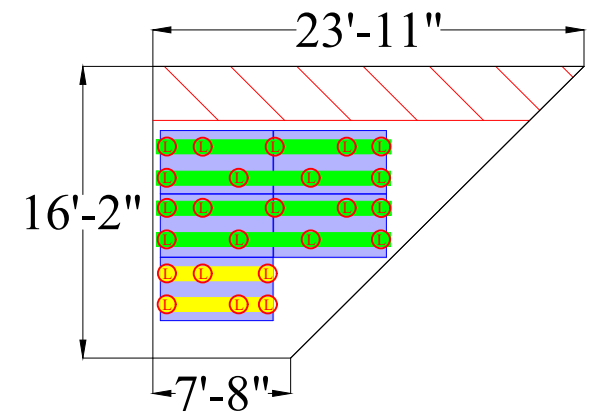

R-2  
# Modules (5)  
Pitch: 18°  
Azimuth: 90°

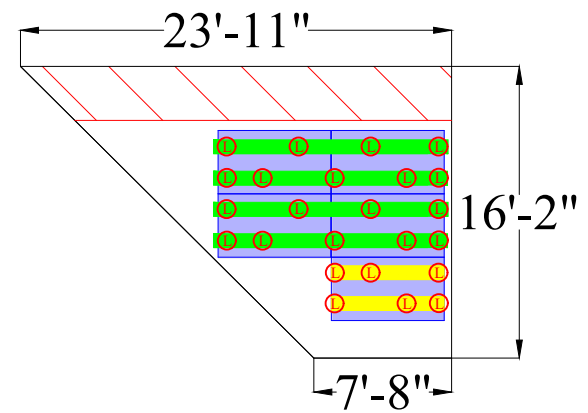

R-3  
# Modules (5)  
Pitch: 18°  
Azimuth: 270°

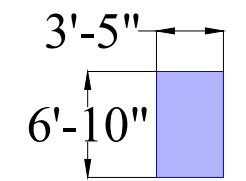

Plans satisfy zones FBC-1510.7.1  
Install will be done to Manufacturer Spec

- Zone 1: Max cantilever is 16" as per manufacturer spec.  
Max Cantilever = Max Span \* (1/3) = 48" \* (1/3) = 16"
- Zone 2e: Max cantilever is 16" as per manufacturer spec.  
Max Cantilever = Max Span \* (1/3) = 48" \* (1/3) = 16"
- Zone 2n: Max cantilever is 8" as per manufacturer spec.  
Max Cantilever = Max Span \* (1/3) = 24" \* (1/3) = 8"
- Zone 2r: Max cantilever is 8" as per manufacturer spec.  
Max Cantilever = Max Span \* (1/3) = 24" \* (1/3) = 8"
- Zone 3e: Max cantilever is 8" as per manufacturer spec.  
Max Cantilever = Max Span \* (1/3) = 24" \* (1/3) = 8"
- Zone 3r: Max cantilever is 8" as per manufacturer spec.  
Max Cantilever = Max Span \* (1/3) = 24" \* (1/3) = 8"

Inverter Type:	(36)Enphase IQ8A-72-2-US
PV Panel:	(36) Sunpal SP460M-72HB
Racking:	Iron Ridge XR-10
Total Wattage:	16,560W DC
Roof Type:	Composition Shingle
Wind Load:	8 to 20 Deg
Fastener Type:	Use Unirac Flashloc Duo

**Customer Info:**  
  
Jean and Garry Sparkman  
311 SE Oak St  
Lake City, FL  
32025

Godwin Engineering and Design, LLC 8378 Foxtail Loop Pensacola, FL 32526 D. Chad Godwin, PE Chad@godwineng.com	<p>Digitally signed by Donnie Godwin Date: 2022.08.24 12:36:05 -05'00'</p>
--	--

933 Clint Moore Rd  
Boca Raton, FL 33487  
800-530-9597

Date:	8/19/2022
Drawn by:	SK
Revised by:	.
Rev #: 00	
Rev Date:	.
Page:	11"x17" S-1A

SP460M-72HB Black

# 425~460W

High Efficiency Low  
LID Mono PERC with  
MBB & Half-cut Technology

## Quality Guarantee

25years Warranty for Materials and Processing

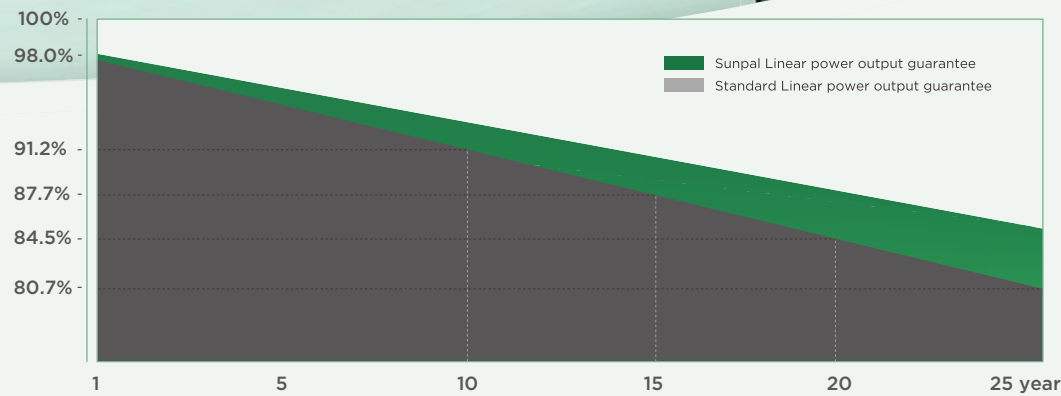

### Complete System and Product Certifications

IEC 61215, IEC 61730, UL 61730  
ISO 9001:2008: ISO Quality Management System  
ISO 14001:2004: ISO Environment Management System  
OHSAS 18001: 2007 Occupational Health and Safety



\* Specifications subject to technical changes and tests. Sunpal Solar reserves the right of interpretation.

**Positive power tolerance** (0 +5W) guaranteed

**High module conversion efficiency** (up to 21.1%)

**Slower power degradation** enabled by Low LID Mono PERC technology: first year <2%, 0.55% year 2-25

**Solid PID resistance** ensured by solar cell process optimization and careful module BOM selection

**Reduced resistive loss** with lower operating current

**Higher energy yield** with lower operating temperature

**Reduced hot spot risk** with optimized electrical design and lower operating current

Black SP460M-72HB **425~460W**

### Design (mm)

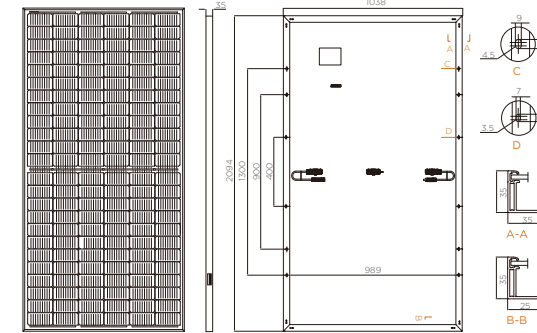

\*Units: mm \*Tolerance: ±2mm

<b>Cell Orientation</b>	144 (6x24)
<b>Junction Box</b>	IP68, three diodes
<b>Output Cable</b>	4mm <sup>2</sup> , 1.2meter in length, length can be customized
<b>Glass</b>	Single glass 3.2mm coated tempered glass
<b>Frame</b>	Anodized aluminum alloy frame
<b>Weight:</b>	23.5kg
<b>Dimension</b>	2094x1038x40mm
<b>Packaging</b>	30pcs per pallet 150pcs per 20'GP 660pcs per 40'HC

<b>Operational Temperature</b>	-40°C~+85°C
<b>Power Output Tolerance</b>	0~+5W
<b>Voc &amp; Isc Tolerance</b>	±3%
<b>Max. System Voltage</b>	DC1500V(IEC/UL)
<b>Max. Series Fuse Rating</b>	20A
<b>NOCT</b>	45±2°C
<b>Safety Class</b>	II
<b>Fire Rating</b>	UL type 1 or 2
<b>Max. Static Load(Front)</b>	5400Pa
<b>Max. Static Load(Back)</b>	3600Pa

### Electrical Characteristics

Model Number	SP425M-72HB		SP430M-72HB		SP435M-72HB		SP440M-72HB		SP445M-72HB		SP450M-72HB		SP455M-72HB		SP460M-72HB	
	STC	NOCT	STC	NOCT	STC	NOCT	STC	NOCT	STC	NOCT	STC	NOCT	STC	NOCT	STC	NOCT
<b>Maximum Power (Pmax/W)</b>	425	317.4	430	321.1	435	324.9	440	328.6	445	332.3	450	336.1	455	339.8	460	343.8
<b>Open Circuit Voltage (Voc/V)</b>	48.3	45.3	48.5	45.5	48.7	45.7	48.9	45.8	49.1	46.0	49.3	46.2	49.5	46.4	49.7	46.6
<b>Short Circuit Current (Isc/A)</b>	11.23	9.08	11.31	9.15	11.39	9.21	11.46	9.27	11.53	9.33	11.60	9.38	11.66	9.43	11.73	9.48
<b>Voltage at Maximum Power (Vmp/V)</b>	40.5	37.7	40.7	37.9	40.9	38.1	41.1	38.3	41.3	38.5	41.5	38.6	41.7	38.8	41.9	38.8
<b>Current at Maximum Power (Imp/A)</b>	10.50	8.42	10.57	8.47	10.64	8.53	10.71	8.59	10.78	8.64	10.85	8.70	10.92	8.75	10.98	8.81
<b>Module Efficiency(%)</b>	19.6		19.8		20.0		20.2		20.5		20.7		20.9		21.1	
<b>Temperature Coefficient of Isc</b>																
<b>Temperature Coefficient of Voc</b>																
<b>Temperature Coefficient of Pmax</b>																

\* STC (Standard Testing Conditions): Irradiance 1000W/m<sup>2</sup>, Cell Temperature 25°C, Spectra at AM1.5

\* NOCT (Nominal Operating Cell Temperature): Irradiance 800W/m<sup>2</sup>, Ambient Temperature 20°C, Spectra at AM1.5, Wind at 1m/s

\*Test uncertainty for Pmax: ±3%

### I-V Curve

Current-Voltage Curve(SP440M-72HB)

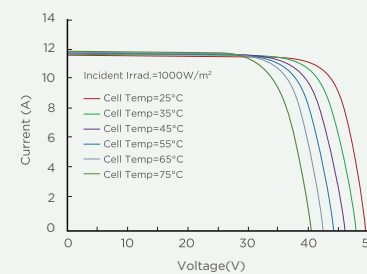

Current-Voltage Curve(SP440M-72HB)

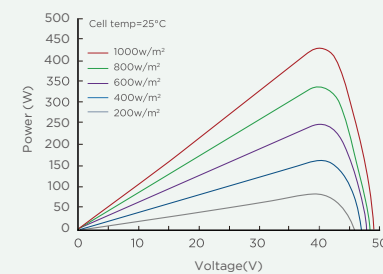

Current-Voltage Curve(SP440M-72HB)

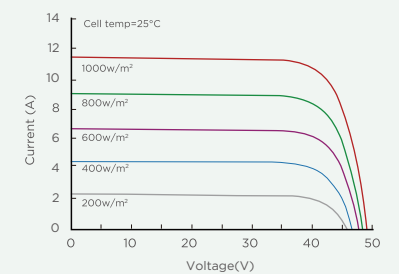

Add: West Changjiang Road, Shushan District, Hefei City, Anhui Province, China.  
Email: info@sunpalpower.com Tel: +86 551 6586 5992  
WhatsApp: +86 180 5513 2023 Web: www.sunpalsolar.com

Q Sunpal Power



Add: West Changjiang Road, Shushan District, Hefei City, Anhui Province, China.  
Email: info@sunpalpower.com Tel: +86 551 6586 5992  
WhatsApp: +86 180 5513 2023 Web: www.sunpalsolar.com

Q Sunpal Power



# IQ8M and IQ8A Microinverters

Our newest IQ8 Microinverters are the industry’s first microgrid-forming, software-defined microinverters with split-phase power conversion capability to convert DC power to AC power efficiently. The brain of the semiconductor-based microinverter is our proprietary application-specific integrated circuit (ASIC) which enables the microinverter to operate in grid-tied or off-grid modes. This chip is built in advanced 55nm technology with high speed digital logic and has super-fast response times to changing loads and grid events, alleviating constraints on battery sizing for home energy systems.



Part of the Enphase Energy System, IQ8 Series Microinverters integrate with the Enphase IQ Battery, Enphase IQ Gateway, and the Enphase App monitoring and analysis software.



IQ8 Series Microinverters redefine reliability standards with more than one million cumulative hours of power-on testing, enabling an industry-leading limited warranty of up to 25 years.



Connect PV modules quickly and easily to IQ8 Series Microinverters using the included Q-DCC-2 adapter cable with plug-n-play MC4 connectors.



IQ8 Series Microinverters are UL Listed as PV Rapid Shut Down Equipment and conform with various regulations, when installed according to manufacturer’s instructions.

### Easy to install

- Lightweight and compact with plug-n-play connectors
- Power Line Communication (PLC) between components
- Faster installation with simple two-wire cabling

### High productivity and reliability

- Produce power even when the grid is down\*
- More than one million cumulative hours of testing
- Class II double-insulated enclosure
- Optimized for the latest high-powered PV modules

### Microgrid-forming

- Complies with the latest advanced grid support\*\*
- Remote automatic updates for the latest grid requirements
- Configurable to support a wide range of grid profiles
- Meets CA Rule 21 (UL 1741-SA) requirements

\* Only when installed with IQ System Controller 2, meets UL 1741.

\*\* IQ8M and IQ8A supports split phase, 240V installations only.

# IQ8M and IQ8A Microinverters

INPUT DATA (DC)		IQ8M-72-2-US	IQ8A-72-2-US
Commonly used module pairings <sup>1</sup>	W	260 – 460	295 – 500
Module compatibility		60-cell/120 half-cell, 66-cell/132 half-cell and 72-cell/144 half-cell	
MPPT voltage range	V	33 – 45	36 – 45
Operating range	V	25 – 58	
Min/max start voltage	V	30 / 58	
Max input DC voltage	V	60	
Max DC current <sup>2</sup> [module Isc]	A	15	
Overvoltage class DC port		II	
DC port backfeed current	mA	0	
PV array configuration		1x1 Ungrounded array; No additional DC side protection required; AC side protection requires max 20A per branch circuit	
OUTPUT DATA (AC)		IQ8M-72-2-US	IQ8A-72-2-US
Peak output power	VA	330	366
Max continuous output power	VA	325	349
Nominal (L-L) voltage/range <sup>3</sup>	V	240 / 211 – 264	
Max continuous output current	A	1.35	1.45
Nominal frequency	Hz	60	
Extended frequency range	Hz	50 – 68	
AC short circuit fault current over 3 cycles	A <sub>rms</sub>	2	
Max units per 20 A (L-L) branch circuit <sup>4</sup>		11	
Total harmonic distortion		<5%	
Overvoltage class AC port		III	
AC port backfeed current	mA	30	
Power factor setting		1.0	
Grid-tied power factor (adjustable)		0.85 leading – 0.85 lagging	
Peak efficiency	%	97.6	97.6
CEC weighted efficiency	%	97	97.5
Night-time power consumption	mW	60	
MECHANICAL DATA			
Ambient temperature range		-40°C to +60°C (-40°F to +140°F)	
Relative humidity range		4% to 100% (condensing)	
DC Connector type		MC4	
Dimensions (HxWxD)		212 mm (8.3") x 175 mm (6.9") x 30.2 mm (1.2")	
Weight		1.08 kg (2.38 lbs)	
Cooling		Natural convection – no fans	
Approved for wet locations		Yes	
Pollution degree		PD3	
Enclosure		Class II double-insulated, corrosion resistant polymeric enclosure	
Environ. category / UV exposure rating		NEMA Type 6 / outdoor	
COMPLIANCE			
Certifications		CA Rule 21 (UL 1741-SA), UL 62109-1, UL1741/IEEE1547, FCC Part 15 Class B, ICES-0003 Class B, CAN/CSA-C22.2 NO. 107.1-01	
		This product is UL Listed as PV Rapid Shut Down Equipment and conforms with NEC 2014, NEC 2017, and NEC 2020 section 690.12 and C22.1-2018 Rule 64-218 Rapid Shutdown of PV Systems, for AC and DC conductors, when installed according to manufacturer’s instructions.	

(1) No enforced DC/AC ratio. See the compatibility calculator at <https://link.enphase.com/module-compatibility>

(2) Maximum continuous input DC current is 10.6A (3) Nominal voltage range can be extended beyond nominal if required by the utility. (4) Limits may vary. Refer to local requirements to define the number of microinverters per branch in your area.

# Enphase IQ Combiner 4/4C

X-IQ-AM1-240-4  
X-IQ-AM1-240-4C



The **Enphase IQ Combiner 4/4C** with Enphase IQ Gateway and integrated LTE-M1 cell modem (included only with IQ Combiner 4C) consolidates interconnection equipment into a single enclosure and streamlines IQ microinverters and storage installations by providing a consistent, pre-wired solution for residential applications. It offers up to four 2-pole input circuits and Eaton BR series busbar assembly.

## Smart

- Includes IQ Gateway for communication and control
- Includes Enphase Mobile Connect cellular modem (CELLMODEM-M1-06-SP-05), included only with IQ Combiner 4C
- Includes solar shield to match Enphase IQ Battery aesthetics and deflect heat
- Flexible networking supports Wi-Fi, Ethernet, or cellular
- Optional AC receptacle available for PLC bridge
- Provides production metering and consumption monitoring

## Simple

- Centered mounting brackets support single stud mounting
- Supports bottom, back and side conduit entry
- Up to four 2-pole branch circuits for 240 VAC plug-in breakers (not included)
- 80A total PV or storage branch circuits

## Reliable

- Durable NRTL-certified NEMA type 3R enclosure
- Five-year limited warranty
- Two years labor reimbursement program coverage included for both the IQ Combiner SKU's
- UL listed

## Enphase IQ Combiner 4/4C

### MODEL NUMBER

IQ Combiner 4 (X-IQ-AM1-240-4)	IQ Combiner 4 with Enphase IQ Gateway printed circuit board for integrated revenue grade PV production metering (ANSI C12.20 +/- 0.5%) and consumption monitoring (+/- 2.5%). Includes a silver solar shield to match the IQ Battery system and IQ System Controller 2 and to deflect heat.
IQ Combiner 4C (X-IQ-AM1-240-4C)	IQ Combiner 4C with Enphase IQ Gateway printed circuit board for integrated revenue grade PV production metering (ANSI C12.20 +/- 0.5%) and consumption monitoring (+/- 2.5%). Includes Enphase Mobile Connect cellular modem (CELLMODEM-M1-06-SP-05), a plug-and-play industrial-grade cell modem for systems up to 60 microinverters. (Available in the US, Canada, Mexico, Puerto Rico, and the US Virgin Islands, where there is adequate cellular service in the installation area.) Includes a silver solar shield to match the IQ Battery and IQ System Controller and to deflect heat.

### ACCESSORIES AND REPLACEMENT PARTS

(not included, order separately)	
Ensemble Communications Kit COMMS-CELLMODEM-M1-06 CELLMODEM-M1-06-SP-05 CELLMODEM-M1-06-AT-05	- Includes COMMS-KIT-01 and CELLMODEM-M1-06-SP-05 with 5-year Sprint data plan for Ensemble sites - 4G based LTE-M1 cellular modem with 5-year Sprint data plan - 4G based LTE-M1 cellular modem with 5-year AT&T data plan
Circuit Breakers BRK-10A-2-240V BRK-15A-2-240V BRK-20A-2P-240V BRK-15A-2P-240V-B BRK-20A-2P-240V-B	Supports Eaton BR210, BR215, BR220, BR230, BR240, BR250, and BR260 circuit breakers. Circuit breaker, 2 pole, 10A, Eaton BR210 Circuit breaker, 2 pole, 15A, Eaton BR215 Circuit breaker, 2 pole, 20A, Eaton BR220 Circuit breaker, 2 pole, 15A, Eaton BR215B with hold down kit support Circuit breaker, 2 pole, 20A, Eaton BR220B with hold down kit support
EPLC-01	Power line carrier (communication bridge pair), quantity - one pair
XA-SOLARSHIELD-ES	Replacement solar shield for IQ Combiner 4/4C
XA-PLUG-120-3	Accessory receptacle for Power Line Carrier in IQ Combiner 4/4C (required for EPLC-01)
XA-ENV-PCBA-3	Replacement IQ Gateway printed circuit board (PCB) for Combiner 4/4C
X-IQ-NA-HD-125A	Hold down kit for Eaton circuit breaker with screws.

### ELECTRICAL SPECIFICATIONS

Rating	Continuous duty
System voltage	120/240 VAC, 60 Hz
Eaton BR series busbar rating	125 A
Max. continuous current rating	65 A
Max. continuous current rating (input from PV/storage)	64 A
Max. fuse/circuit rating (output)	90 A
Branch circuits (solar and/or storage)	Up to four 2-pole Eaton BR series Distributed Generation (DG) breakers only (not included)
Max. total branch circuit breaker rating (input)	80A of distributed generation / 95A with IQ Gateway breaker included
Production metering CT	200 A solid core pre-installed and wired to IQ Gateway
Consumption monitoring CT (CT-200-SPLIT)	A pair of 200 A split core current transformers

### MECHANICAL DATA

Dimensions (WxHxD)	37.5 x 49.5 x 16.8 cm (14.75" x 19.5" x 6.63"). Height is 21.06" (53.5 cm) with mounting brackets.
Weight	7.5 kg (16.5 lbs)
Ambient temperature range	-40° C to +46° C (-40° to 115° F)
Cooling	Natural convection, plus heat shield
Enclosure environmental rating	Outdoor, NRTL-certified, NEMA type 3R, polycarbonate construction
Wire sizes	• 20 A to 50 A breaker inputs: 14 to 4 AWG copper conductors • 60 A breaker branch input: 4 to 1/0 AWG copper conductors • Main lug combined output: 10 to 2/0 AWG copper conductors • Neutral and ground: 14 to 1/0 copper conductors Always follow local code requirements for conductor sizing.
Altitude	To 2000 meters (6,560 feet)

### INTERNET CONNECTION OPTIONS

Integrated Wi-Fi	802.11b/g/n
Cellular	CELLMODEM-M1-06-SP-05, CELLMODEM-M1-06-AT-05 (4G based LTE-M1 cellular modem). Note that an Enphase Mobile Connect cellular modem is required for all Ensemble installations.
Ethernet	Optional, 802.3, Cat5E (or Cat 6) UTP Ethernet cable (not included)

### COMPLIANCE

Compliance, IQ Combiner	UL 1741, CAN/CSA C22.2 No. 107.1, 47 CFR, Part 15, Class B, ICES 003 Production metering: ANSI C12.20 accuracy class 0.5 (PV production) Consumption metering: accuracy class 2.5
Compliance, IQ Gateway	UL 60601-1/CANCSA 22.2 No. 61010-1



To learn more about Enphase offerings, visit [enphase.com](http://enphase.com)



To learn more about Enphase offerings, visit [enphase.com](http://enphase.com)

© 2021 Enphase Energy. All rights reserved. Enphase, the Enphase logo, IQ Combiner 4/4C, and other names are trademarks of Enphase Energy, Inc. Data subject to change. 10-21-2021





# XR Rail Family

## Solar Is Not Always Sunny

Over their lifetime, solar panels experience countless extreme weather events. Not just the worst storms in years, but the worst storms in 40 years. High winds capable of ripping panels from a roof, and snowfalls weighing enough to buckle a panel frame.

XR Rails are the structural backbone preventing these results. They resist uplift, protect against buckling and safely and efficiently transfer loads into the building structure. Their superior spanning capability requires fewer roof attachments, reducing the number of roof penetrations and the amount of installation time.

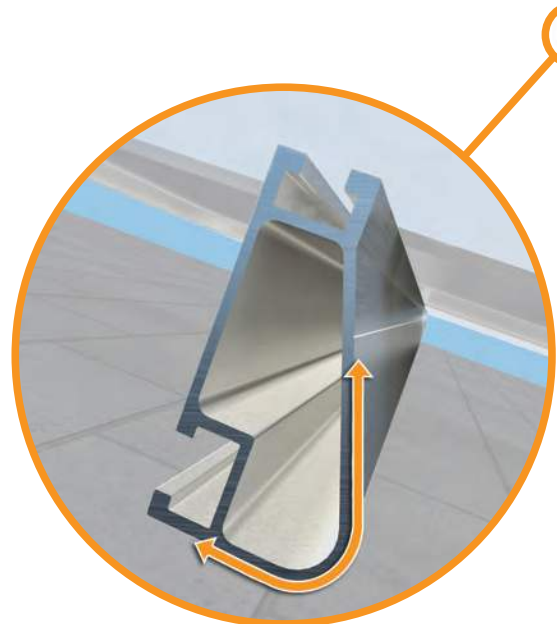
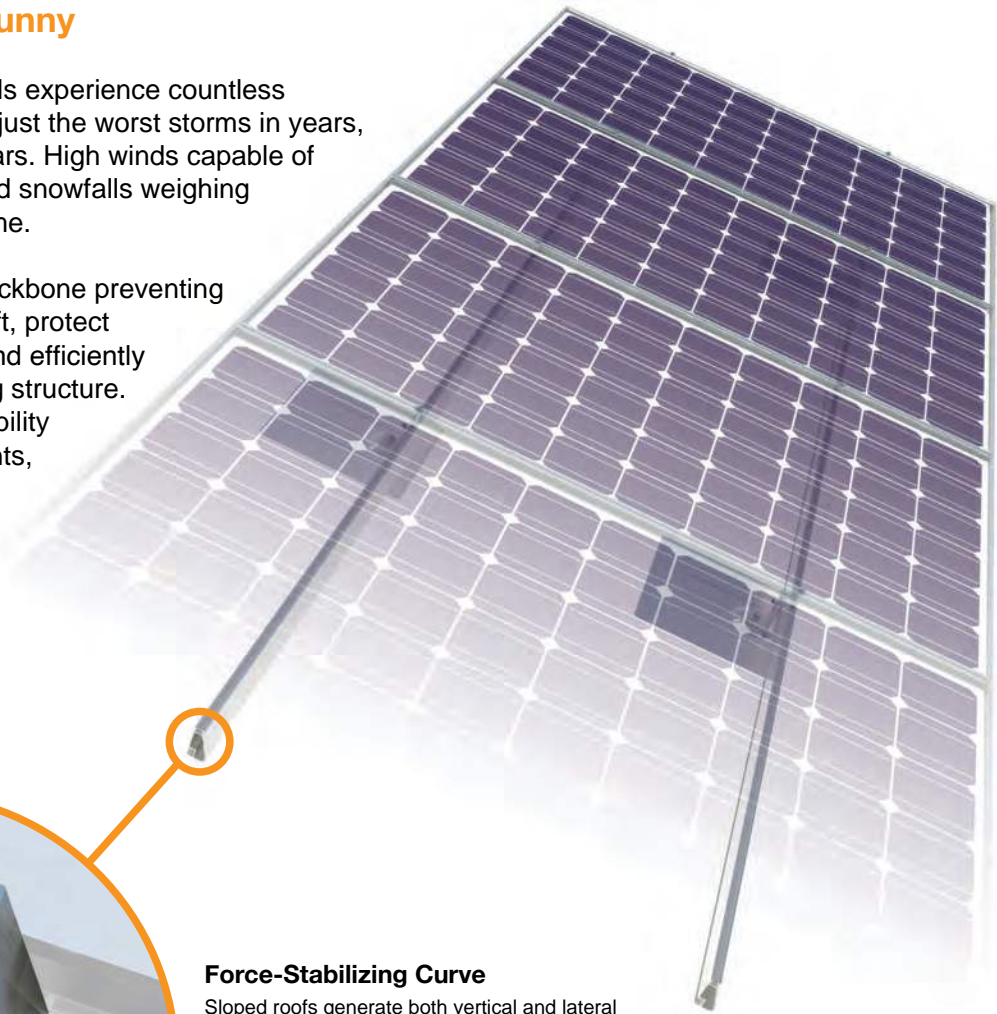

### Force-Stabilizing Curve

Sloped roofs generate both vertical and lateral forces on mounting rails which can cause them to bend and twist. The curved shape of XR Rails is specially designed to increase strength in both directions while resisting the twisting. This unique feature ensures greater security during extreme weather and a longer system lifetime.

### Compatible with Flat & Pitched Roofs



XR Rails are compatible with FlashFoot and other pitched roof attachments.



IronRidge offers a range of tilt leg options for flat roof mounting applications.

### Corrosion-Resistant Materials

All XR Rails are made of 6000-series aluminum alloy, then protected with an anodized finish. Anodizing prevents surface and structural corrosion, while also providing a more attractive appearance.



## XR Rail Family

The XR Rail Family offers the strength of a curved rail in three targeted sizes. Each size supports specific design loads, while minimizing material costs. Depending on your location, there is an XR Rail to match.



### XR10

XR10 is a sleek, low-profile mounting rail, designed for regions with light or no snow. It achieves spans up to 6 feet, while remaining light and economical.

- 6' spanning capability
- Moderate load capability
- Clear & black anodized finish
- Internal splices available



### XR100

XR100 is the ultimate residential mounting rail. It supports a range of wind and snow conditions, while also maximizing spans up to 10 feet.

- 10' spanning capability
- Heavy load capability
- Clear & black anodized finish
- Internal splices available



### XR1000

XR1000 is a heavyweight among solar mounting rails. It's built to handle extreme climates and spans up to 12 feet for commercial applications.

- 12' spanning capability
- Extreme load capability
- Clear anodized finish
- Internal splices available

## Rail Selection

The table below was prepared in compliance with applicable engineering codes and standards.\* Values are based on the following criteria: ASCE 7-16, Gable Roof Flush Mount, Roof Zones 1 & 2e, Exposure B, Roof Slope of 8 to 20 degrees and Mean Building Height of 30 ft. Visit [IronRidge.com](http://IronRidge.com) for detailed certification letters.

Load		Rail Span					
Snow (PSF)	Wind (MPH)	4'	5' 4"	6'	8'	10'	12'
None	90	XR10		XR100		XR1000	
	120						
	140						
	160						
20	90						
	120						
	140						
	160						
30	90						
	160						
40	90						
	160						
80	160						
120	160						

\*Table is meant to be a simplified span chart for conveying general rail capabilities. Use approved certification letters for actual design guidance.

# FLASHLOC™ DUO

THE MOST VERSATILE DIRECT TO DECK ATTACHMENT



**FLASHLOC™ DUO** is the most versatile direct to deck and rafter attachment for composition shingle and rolled comp roofs. The all-in-one mount installs fast — no kneeling on hot roofs to install flashing, no prying or cutting shingles, no pulling nails. Simply drive the required number of screws to secure the mount and inject sealant into the base. **FLASHLOC's** patented TRIPLE SEAL technology preserves the roof and protects the penetration with a permanent pressure seal. Kitted with two rafter screws, sealant and hardware for maximum convenience (deck screws sold separately). Don't just divert water, **LOC it out!**



## PROTECT THE ROOF

Install a high-strength waterproof attachment without lifting, prying or damaging shingles.



## LOC OUT WATER

With an outer shield **1** contour-conforming gasket **2** and pressurized sealant chamber **3** the Triple Seal technology delivers a 100% waterproof connection.



## HIGH-SPEED INSTALL

Simply drive the required number of screws and inject sealant into the port **4** to create a permanent pressure seal.

APRIL2021\_FLASHLOCDOU\_V1

# FLASHLOC™ DUO

INSTALLATION GUIDE



## PRE-INSTALL: CLEAN SURFACE AND MARK LOCATION

Ensure existing roof structure is capable of supporting the roof attachment point loads stated in the racking system engineering specifications. Clean roof surface of dirt, debris, snow and ice.

Snap chalk lines for attachment rows. On shingle roofs, snap lines 1/4" below upslope edge of shingle course. This line will be used to align the upper edge of the mount.

**NOTE:** Space mounts per racking system installation specifications.



## STEP ONE: SECURE

**ATTACHING TO A RAFTER:** Place FLASHLOC DUO over rafter location with sealant port on up-slope side and align upper edge of mount with horizontal chalk line. Secure mount with the two (2) provided rafter screws. **BACKFILL ALL PILOT HOLES WITH SEALANT.**

**ATTACHING TO SHEATHING:** Place FLASHLOC DUO over desired location with sealant port on up-slope side and align upper edge of mount with horizontal chalk line. Secure mount with the two (2) provided rafter screws. Next, secure mount with four (4) deck screws by drilling through the FLASHLOC DUO deck mount hole locations. Unirac recommends using a drill as opposed to an impact gun to prevent over-tightening or stripping roof sheathing.

**IMPORTANT:** SECURELY ATTACH MOUNT BUT DO NOT OVERTIGHTEN SCREWS.



## STEP TWO: SEAL

Insert tip of UNIRAC approved sealant into port and inject until sealant exits vent. Follow sealant manufacturer's instructions. Follow sealant manufacturer's cold weather application guidelines, if applicable.

**NOTE:** When FLASHLOC DUO is installed over gap between shingle tabs or vertical joints, fill gap/joint with sealant between mount and upslope edge of shingle course.

**CUT SHINGLES AS REQUIRED:** DO NOT INSTALL THE FLASHLOC SLIDER ACCROSS THICKNESS VARIATIONS GREATER THAN 1/8" SUCH AS THOSE FOUND IN HIGH DEFINITION SHINGLES.

**NOTE:** If an exploratory hole falls outside of the area covered by the sealant, flash hole accordingly.  
**NOTE:** Read and comply with the Flashloc Duo Design & Engineering Guide prior to design and installation of the system.

USE ONLY UNIRAC APPROVED SEALANTS. PLEASE CONTACT UNIRAC FOR FULL LIST OF COMPATIBLE SEALANTS.

Continue array installation. Refer to SOLARMOUNT or NXT HORIZON Installation Guide for the remaining system installation.



# FASTER INSTALLATION. 25-YEAR WARRANTY.

FOR QUESTIONS OR CUSTOMER SERVICE VISIT UNIRAC.COM OR CALL (505) 248-2702

# FASTER INSTALLATION. 25-YEAR WARRANTY.

FOR QUESTIONS OR CUSTOMER SERVICE VISIT UNIRAC.COM OR CALL (505) 248-2702

# GODWIN ENGINEERING AND DESIGN, LLC

---

8378 Foxtail Loop, Pensacola, FL 32526 | (850)712-4219 | [chad@godwineng.com](mailto:chad@godwineng.com)

August 24, 2022

To: Columbia County Building Department  
135 NE Hernando Ave  
Lake City, FL 32055

Re: Sparkman- Residential PV Roof Mount Installation  
311 SE Oak St  
Lake City, FL 32025

Plan Reviewer,

This letter is regarding the installation of a new roof mounted Solar PV System on the existing residential structure at the address above. I have reviewed the attachment plan and have determined that the roof mounted PV system is in compliance with the applicable sections of the following Codes as amended and adopted by the jurisdiction:

2020 Florida Building Code 7<sup>th</sup> Edition, FBC  
ASCE 7 Min. Design Loads for Buildings & Other Structures

Per 2020 FBC, the Roof Mounted PV system will be subject to the following design criteria:  
Design Wind Speed ( $V_{ult}$ ) - 120mph 3sec gust, Exposure Category - C

The PV System consist of the modules, railing, and connection hardware. The system will add a dead load of approximately 3 psf to the roof.

The existing roof covering is Asphalt Shingle with min. ½" plywood decking and 2" x 4" roof trusses 24" O.C. The roofing, decking, and roof trusses are in good condition. The existing structure will be adequate for supporting the additional PV dead load and wind loads.

The securement method of the PV system is to be flush mounted to the asphalt shingle roof with the Ironridge railing and Unirac Flashloc Duo. The attachments can be attached up to 48" apart in roof zones 1, & 2e and 24" apart in roof zones 2r, 2n, 3e & 3r. The mounts should be staggered, where possible, to allow distribution of the design loads evenly to the structure. The mounts shall be installed using 2 x #12-14 x 2.5" Self-drilling Screws with minimum 2-5/16" thread length.

Please see attached documents and contact me should you have any questions.

Sincerely,

D. Chad Godwin, PE 81360  
Exp. 02/28/2023



THIS ITEM HAS BEEN ELECTRONICALLY  
SIGNED AND SEALED BY DONNIE GRAY  
GODWIN USING A DIGITAL SIGNATURE AND  
DATE. PRINTED COPIES OF THIS DOCUMENT  
ARE NOT CONSIDERED SIGNED AND SEALED  
AND THE SIGNATURE MUST BE VERIFIED ON  
ANY ELECTRONIC COPIES.

Digitally  
signed by  
Donnie  
Godwin  
Date:  
2022.08.24  
12:36:18  
-05'00'

Wind Load Parameters - Inputs				Wind Load Parameters			
Risk Category	II	Table 1.5-1		Wind Speed (asd)	93	mph	FRC R301.2.1.3
Basic Wind Speed (Ult)	120	mph	Figure 26.5-1B	Effective Wind Area	23.40	ft <sup>2</sup>	26.20
Roof Angle	8° to 20°			Wind Directionality	K <sub>d</sub>	0.85	Table 26.6-1
Roof Type	Gable			Topographic factor	K <sub>zt</sub>	1.00	26.8 or 26.8.2
Exposure Cat.	B, C, or D	C	Section 26.7	Ground Elevation Factor	K <sub>e</sub>	1.00	Table 26.9-1
Mean Roof Height	h	15.00	ft	Velocity Exposure Coefficient	K <sub>z</sub>	0.85	Table 26.10-1
Roof attachment	2 x 12-14 Self-Drilling screw to 16ga steel			Array Edge Factor	γ <sub>e</sub>	1.50	29.4.4 *Modules are considered Exposed
Rafter/Truss Spacing	24 in O.C.			Solar Panel Equalization Factor	γ <sub>s</sub>	0.65	Fig. 29.4-8
No. of Rails	2			Velocity Pressure	q <sub>h</sub>	15.98	psf q <sub>h</sub> =0.00256 K <sub>z</sub> K <sub>zt</sub> K <sub>e</sub> V <sup>2</sup>
No. of Modules - Portrait	26			Added Safety Factor	1.2		
No. of Modules - Landscape	10			Allowable Pullout per mount	650.0	lbs	
Module Model Number	SP4xxM-72HB 425-460			0.4h or 0.6h	6.00	ft	Flat - 0.6h, Gable, Hip - 0.4h
bldg. least horizontal dim (typ.)	360 in			10% of least horizontal dim	3.00	ft	10% of least hor. Dim. Or 0.4h, whichever is smaller, but not less than either 4% of least hor. Or 3ft. (flat roof - 0.6h)
Elevation	<1000 ft			Roof Zone Set Back	a	3.00	ft
Est. # of attachment points	102			h <sub>2</sub>	5	in	Not > 10in(panel height above roof)
<b>PV Dead Load</b>				<b>Module and Racking Specs</b>			
# of Modules	36			Dimensions, LxWxH (in)	82.44 x 40.87 x 1.57		
Module	W <sub>mod</sub>	52 lbs		Width	3.41	ft	
Array	W <sub>mods</sub>	1865 lbs		Length	6.87	ft	
Micro/optimizer	W <sub>mic</sub>	144 lbs		Module Area	23.40	ft <sup>2</sup>	
PV Rail	W <sub>PV rail</sub>	32 lbs		<b>Module load ratings</b>			
Total Weight	W <sub>total</sub>	2041 lbs				Ultimate	Allowable
Total Area	A <sub>T</sub>	842.33 ft <sup>2</sup>		Load Rating - Snow(psf)	113.4	75.6	
Dead Load	D <sub>PV</sub>	2.42 psf		Load Rating - Wind(psf)	-75.6	-50.4	
Weight/attachment	20.0 lbs			<b>Notes</b>			
<b>PV Attachment - Results</b>							
<b>Roof Zones - Gable 8° to 20°</b>							
	1	2e	2r	2n	3e	3r	
GC <sub>z</sub> - Uplift	-2.0	-2.0	-2.6	-2.6	-2.6	-3.0	
GC <sub>z</sub> - Down	0.5	0.5	0.5	0.5	0.5	0.5	
p = q <sub>h</sub> (GC <sub>z</sub> )(γ <sub>e</sub> )(γ <sub>s</sub> )	-28.9	-28.9	-38.2	-38.2	-38.2	-44.5	psf 29.4-7
p = q <sub>h</sub> (GC <sub>z</sub> )(γ <sub>e</sub> )(γ <sub>s</sub> )	7.8	7.8	7.8	7.8	7.8	7.8	psf 29.4-7
Max Allowable Span	4	4	4	4	4	2	ft *notes
Max Cantilever (in)	16	16	16	16	16	8	Max span * 33% (in)



Digitally signed by Donnie Godwin Date: 2022.08.24 12:36:27 -05'00'

THIS FILE HAS BEEN ELECTRONICALLY SIGNED AND SEALED BY DONNIE CHAD GODWIN USING A DIGITAL SIGNATURE AND DATE. PRINTED COPIES OF THIS DOCUMENT ARE NOT CONSIDERED SIGNED AND SEALED AND THE SIGNATURE MUST BE VERIFIED ON ANY ELECTRONIC COPIES.