

THIS ITEM HAS BEEN ELECTRONICALLY SIGNED AND SEALED BY MARK V. RICHTER, P.E. #56196 ON THE DATE AND/OR TIME USING A DIGITAL SIGNATURE. PRINTED COPIES OF THIS DOCUMENT ARE NOT CONSIDERED SIGNED AND SEALED AND THE SIGNATURE MUST BE VERIFIED BY THIRD PARTY CERTIFICATE AUTHORITY ON ANY ELECTRONIC COPY. (FAC 61G15-23.004)

03-04-2026  
 SENYB ENGINEERING, LLC  
 CA LIC. NO: 30244

**COLUMN LOADS:**

① = 7219 LBS.    ② = 7219 LBS.    ③ = 1450 LBS.  
 ④ = 1450 LBS.

**SYMBOLS**

17.5"x25.5" ABS PAD = 4500 LBS. CAPACITY

24"x24" ABS PAD = 6000 LBS. CAPACITY

(3) 17.5"x25.5" ABS PAD = 9000 LBS. CAPACITY (TOP PAD IS LAID IN THE OPPOSITE DIRECTION TO THE BOTTOM PADS)

13"x26" ABS PAD = 3562 LBS. CAPACITY

-FRAME TIE-DOWN FASTENED TO GROUND ANCHOR

-COLUMN ANCHOR STRAP FASTENED TO GROUND ANCHOR

-LONGITUDINAL ANCHOR STRAP LOCATIONS

- STRUCTURAL LOAD LIMITATIONS:**  
 CODE EDITION: 2023 FLORIDA BUILDING CODE (8TH EDITION) & ASCE 7-22
1. ULTIMATE DESIGN WIND SPEED: 120 MPH WIND SPEED
  2. NOMINAL DESIGN WIND SPEED: 93 MPH WIND SPEED
  3. WIND EXPOSURE CATEGORY: "C"
  4. IMPORTANCE FACTOR: 1.0
  5. DESIGN ROOF LIVE LOAD: 20 PSF
  6. DESIGN FLOOR LIVE LOAD: 40 PSF
  7. MIN. ASSUMED SOIL BEARING CAPACITY: 1500 PSF
  8. OCCUPANCY CLASSIFICATION: R3
  9. CONSTRUCTION TYPE: VB
  10. THIS BUILDING IS NOT DESIGNED FOR PLACEMENT IN A HIGH VELOCITY HURRICANE ZONE AS DEFINED BY THE FBC.
  11. THIS BUILDING IS NOT DESIGNED TO BE SUBMERGED OR SUBJECT TO WAVE ACTION WHEN LOCATED IN A FLOOD PRONE OR ZONE AREA. THE BOTTOM OF THE STRUCTURAL I-BEAM MUST BE LOCATED ABOVE THE BUILDING SITE FLOOD PLANE LEVEL FOR THIS BUILDING TO BE LOCATED IN A FLOOD PRONE OR ZONE AREA. THE GRADE AT THE BUILDING SITE MUST BE ABOVE THE FLOOD PLANE LEVEL.

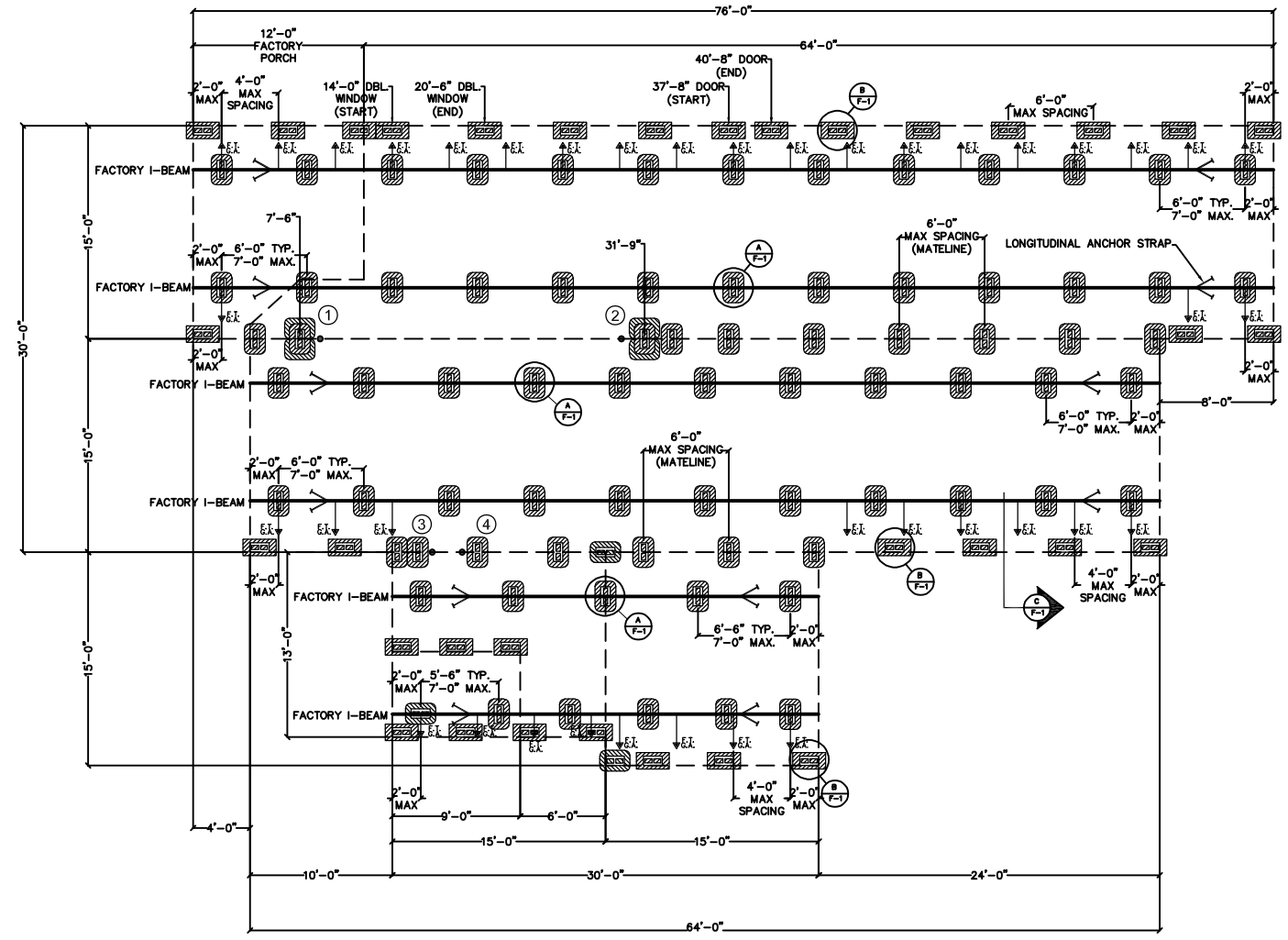

THE TIE-DOWN STRAPS ARE INSTALLED BY THE MANUFACTURER, AND THEREFORE THE LOCATION OF THE STRAPPING COULD AFFECT THE LOCATION OF THE PIERS BASED UPON THE PROVIDED FOUNDATION PLAN. THE PERIMETER PIERS MAYBE OFFSET FROM THE DESIGN LOCATION IF THEY INTERFERE WITH THE TIE-DOWN STRAP PERIMETER PIERS MUST BE INSTALLED AT ALL PERIMETER PIERS LABELS SPECIFIED BY MANUFACTURER

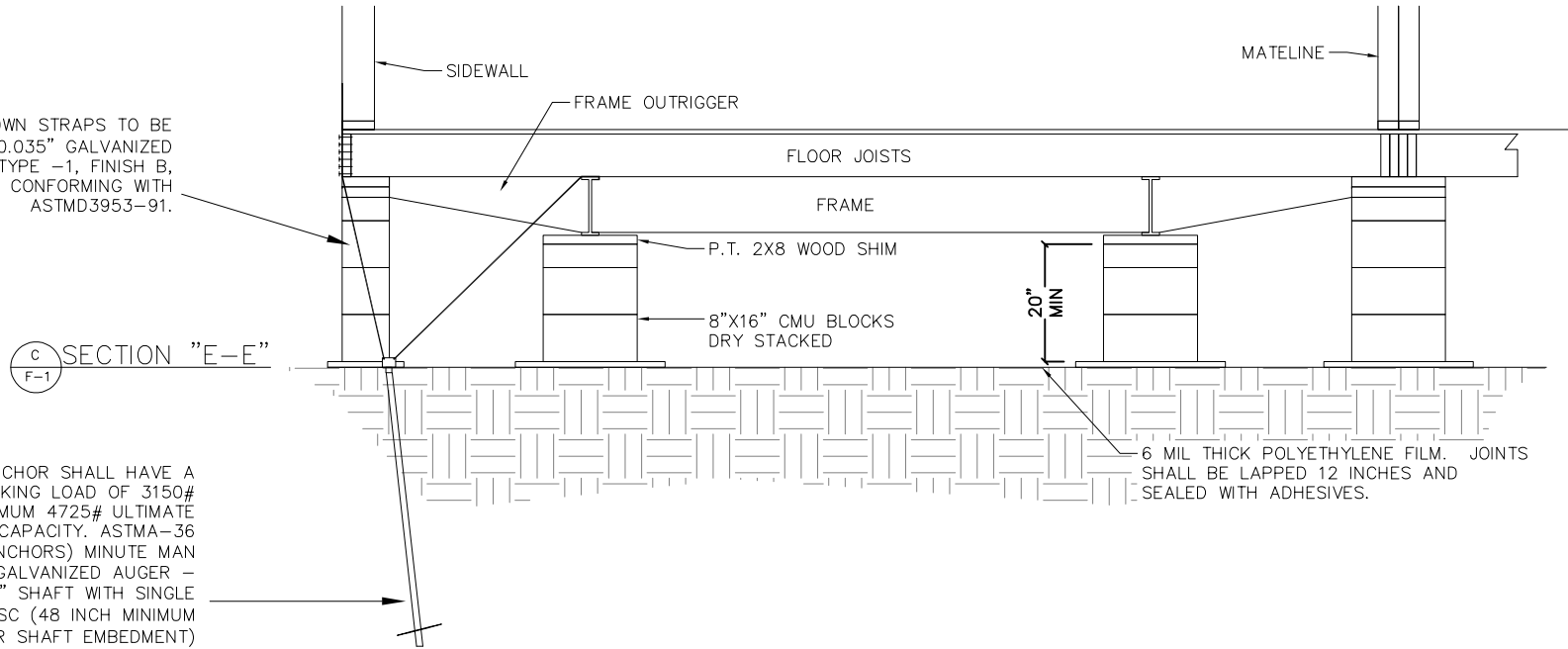

THIS FOUNDATION IS DESIGNED TO SUPPORT THE SUBJECT STRUCTURE AS WELL AS ANCHOR THE STRUCTURE IN A MANNER CONSISTENT WITH THE 2023 FBC REQUIREMENTS FOR A SITE BUILT PERMANENT FOUNDATION AND IS NOT DESIGNED TO BE MOVED ONCE SO ERECTED

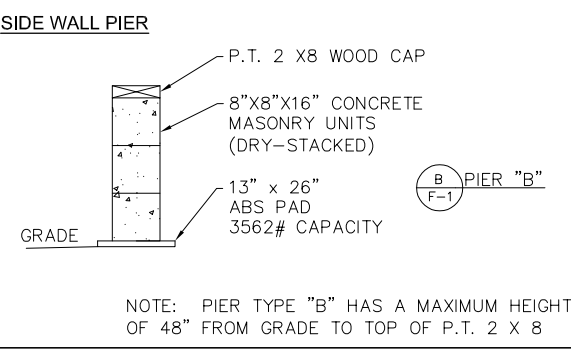
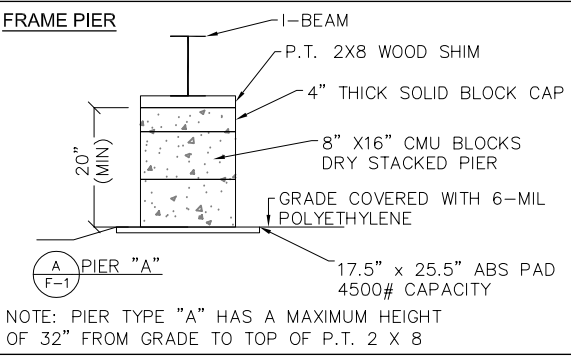

**TIE DOWN STRAP SPECIFICATION**  
 ALL TIE-DOWN STRAPS, ETC., SHALL BE TYPE 1 FINISH B, GRADE 1, STEEL STRAPPING 109,000 MINIMUM YIELD STRENGTH, .035" MINIMUM THICKNESS (PLUS OR MINUS .002 IN.-0.05MM) FINISH B - HOT-DIPPED GALVANIZED ZINC COATING (ASTM STANDARD 123- 89A): .6 OUNCES PER SQUARE FOOT PER SURFACE, 4750 POUNDS MINIMUM BREAK STRENGTH, MARKED EVERY 12 TO 15 INCHES ( MANUFACTURER'S NAME AND ASTM SPEC. D3953-31), 1 1/4" WIDTH.

**GROUND ANCHOR SPECIFICATIONS**  
 GROUND ANCHOR SHALL HAVE A MINIMUM WORKING LOAD OF 3150# AND A MINIMUM 4725 ULTIMATE LOAD CAPACITY. ASTMA-36 (GROUND ANCHORS) MINUTE MAN ANCHOR- GALVANIZED AUGER 5/8" X 48" SHAFT WITH SINGLE 6" DISC (48 INCH MINIMUM ANCHOR SHAFT EMBEDMENT)

**FBC- RESIDENTIAL R404.1.9**  
 PIER CAP- HOLLOW MASONRY PIERS SHALL BE CAPPED WITH 4 INCHES OF SOLID MASONRY OR CONCRETE, A MASONRY CAP BLOCK, OR SHALL HAVE CAVITIES OF THE TOP COURSE FILLED WITH CONCRETE OR GROUT.

- FOUNDATION NOTES:**
1. BLOCKING SPACING BASED ON 20PSF LIVE LOAD ON ROOF AND 1500 PSF SOIL BEARING CAPACITY.
  2. CONCRETE BLOCKS ARE ONLY RATED AT 8000 POUNDS, 8000 POUNDS PIERS OR HIGHER MUST BE DOUBLE BLOCKED.
  3. ALL SIDEWALLS' ANCHORS ARE SPACED PER PLAN AND FOUR FOOT GROUND ANCHOR MAY BE USED.
  4. ALL THE MASONRY PIERS MAY BE INSTALLED IN A DRY STACK SUBJECT TO LOCAL JURISDICTION.
  5. ALL TIE DOWN ANCHORS SHALL HAVE A MINIMUM 4,725 LB. ULTIMATE CAPACITY AND SHALL BE INSTALLED PER THE MANUFACTURER'S SPECIFICATIONS.
  6. THE STEEL FRAME OF HOME IS NOT FOR USE OF RELOCATION OF HOME AFTER SETUP, AND IS INTENDED FOR USE AS A PERMANENT FOUNDATION.
  7. ALL PIERS SHOULD BE CONSTRUCTED OF 8"x8"x16" CONCRETE MASONRY UNITS CONFORMING TO ASTM C90
  8. INSTALL BLOCK PIER ON EACH SIDE OF ALL EXTERIOR DOOR OPENINGS.
  9. I-BEAM SUPPORT PIERS MAY BE INSTALLED LATERALLY (90 DEGREES FROM THE ORIENTATION SHOWN ON THE FOUNDATION PLAN). MUST BE LOCATED DIRECTLY BELOW THE I-BEAM CENTERLINE.
  10. WOOD SHIMS MAY BE INSTALLED WHEN NECESSARY BETWEEN THE I-BEAM AND THE TOP OF THE PIER, SHIMS SHALL BE FREE OF KNOTS, SPLITS, AND SIMILAR IMPERFECTIONS. SHIMS SHALL BE P.T. LUMBER, CEDAR, OR ABS AND BEARING AT ALL CONTACT POINTS SHALL NOT BE LESS THAN 2/3 OF THE BEARING PRIOR TO ADDING THE SHIMS.

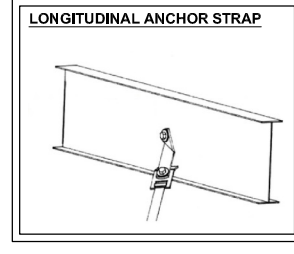

Senyb Engineering Services  
 50 W. Central Ave.  
 Suite B  
 Lake Wales, FL 33859  
 Office: 863-589-5980  
 Email: engineer@senybenengineering.com  
 www.senybenengineering.com  
 © COPYRIGHT 2017

THESE STANDARDS AND PLANS MEET THE 2023 F.B.C. - RESIDENTIAL (8th EDITION)- EXPOSURE "C"

V<sub>ULT</sub> =ULTIMATE DESIGN WIND SPEED = 120 MPH (RISK CATEGORY II BUILDING)  
 V<sub>ASD</sub> =NOMINAL DESIGN WIND SPEED = 93 MPH (RISK CATEGORY II BUILDING) (TABLE 1609.3.1)

MARK V. RICHTER, P.E. # 56196  
 50 W. CENTRAL AVE. SUITE B  
 LAKE WALES, FL 33853  
 OFFICE: 863-589-5980

DRAWING INFORMATION	
NAME:	C.C.C.
DATE:	03-04-2026
SCALE:	NOT PRINTED TO SCALE

CUSTOMER: DAVID & ANGELA MOORE  
 ADDRESS: 1716 NW MOORE FARMS RD., LAKE CITY, FL 32055  
 MANUFACTURER: DEER VALLEY HOMEBUILDERS- 45' X 76' (ON-FRAME)  
 FOUNDATION PLAN  
 PROVIDED BY  
**Senyb Engineering Services**  
 LAKE WALES, FLORIDA 33853

DESIGNED FOR 20 PSF ROOF LIVE LOAD AND 1500 PSF SOIL BEARING CAPACITY

**F-1**

SHEET 1 OF 1