

This document has been electronically signed and sealed using a Digital Signature. Printed copies without an original signature must be verified using the original electronic version.

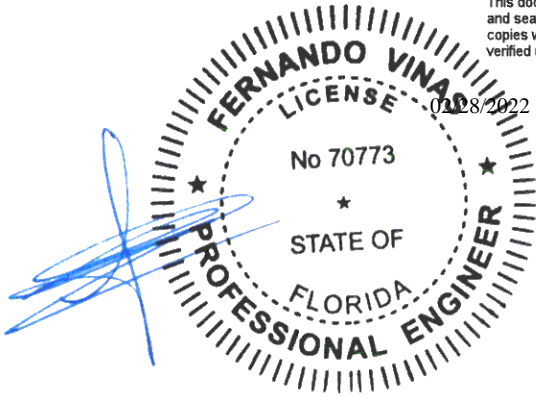

Alpine, an ITW Company
6750 Forum Drive, Suite 305
Orlando, FL 32821
Phone: (800)755-6001
www.alpineitw.com



COA#0-278

Site Information:	Page 1:
Customer: W. B. Howland Company, Inc.	Job Number: 22-6970
Job Description: Jordan - Lancaster Model	
Address: Lake City, FL 32055	

Job Engineering Criteria:	
Design Code: FBC 2017 RES	IntelliVIEW Version: 19.02.02B through 21.01.01A JRef #: 1Xdd2150013
Wind Standard: ASCE 7-10 Wind Speed (mph): 130	Design Loading (psf): 40.00
Building Type: Closed	

This package contains general notes pages, 51 truss drawing(s) and 7 detail(s).

Item	Drawing Number	Truss
1	059.22.1338.38553	A01
3	056.22.1250.50176	A03
5	056.22.1250.50177	A05
7	056.22.1250.50269	B01
9	056.22.1250.50832	B03
11	059.22.1339.23300	B05
13	059.22.1339.32960	B07
15	059.22.1339.44630	B09
17	059.22.1340.02633	B11
19	059.22.1340.13780	B13
21	059.22.1340.24483	B15
23	059.22.1340.40987	B17
25	056.22.1250.50926	C02
27	059.22.1340.47717	D01
29	059.22.1342.00570	G01
31	059.22.1342.36040	HJ01
33	059.22.1343.54837	J01
35	059.22.1343.58850	J03
37	059.22.1344.02893	J05
39	059.22.1344.08883	J07
41	059.22.1344.14257	J09
43	059.22.1344.33327	J11
45	056.22.1250.50316	PB01
47	056.22.1250.51004	PB03
49	059.22.1344.41913	PB05
51	059.22.1344.49890	PB07

Item	Drawing Number	Truss
2	059.22.1338.46397	A02
4	056.22.1250.50208	A04
6	059.22.1339.14683	A06
8	056.22.1250.50379	B02
10	056.22.1250.50785	B04
12	059.22.1339.27660	B06
14	059.22.1339.35790	B08
16	059.22.1339.54370	B10
18	059.22.1340.07970	B12
20	059.22.1340.20760	B14
22	059.22.1340.31443	B16
24	059.22.1340.44183	C01
26	056.22.1250.50426	C03
28	059.22.1340.51820	D02
30	059.22.1342.22330	G02
32	059.22.1343.52390	HJ02
34	059.22.1343.56780	J02
36	059.22.1344.00207	J04
38	059.22.1344.05433	J06
40	059.22.1344.10823	J08
42	059.22.1344.21120	J10
44	059.22.1338.24397	J12
46	056.22.1250.50363	PB02
48	059.22.1344.40497	PB04
50	059.22.1344.44170	PB06
52	A14015ENC101014	

This document has been electronically signed and sealed using a Digital Signature. Printed copies without an original signature must be verified using the original electronic version.



Alpine, an ITW Company
 6750 Forum Drive, Suite 305
 Orlando, FL 32821
 Phone: (800)755-6001
 www.alpineitw.com

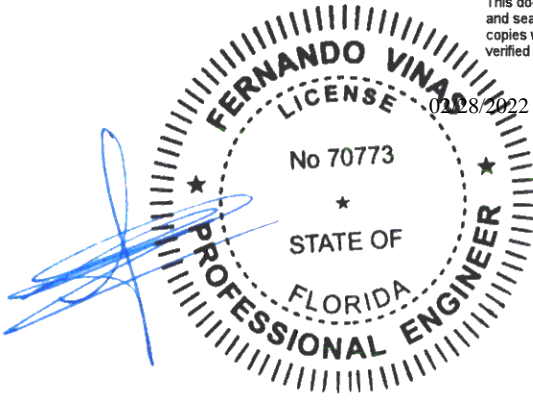

COA#0-278

Site Information:	Page 2:
Customer: W. B. Howland Company, Inc.	Job Number: 22-6970
Job Description: Jordan - Lancaster Model	
Address: Lake City, FL 32055	

Item	Drawing Number	Truss
53	A14030ENC101014	
55	CNNAILSP1014	
57	PB160101014	

Item	Drawing Number	Truss
54	BRCLBSUB0119	
56	GBLLETIN0118	
58	VAL160101014	

General Notes

Truss Design Engineer Scope of Work, Design Assumptions and Design Responsibilities:

The design responsibilities assumed in the preparation of these design drawings are those specified in ANSI/TPI 1, Chapter 2; and the National Design Standard for Metal Plate Connected Wood Truss Construction, by the Truss Plate Institute. The truss component designs conform to the applicable provisions of ANSI/TPI 1 and NDS, the National Design Specification for Wood Construction by AWC. The truss component designs are based on the specified loading and dimension information furnished by others to the Truss Design Engineer. The Truss Design Engineer has no duty to independently verify the accuracy or completeness of the information provided by others and may rely on that information without liability. The responsibility for verification of that information remains with others neither employed nor controlled by the Truss Design Engineer. The Truss Design Engineer's seal and signature on the attached drawings, or cover page listing these drawings, indicates acceptance of professional engineering responsibility solely for the truss component designs and not for the technical information furnished by others which technical information and consequences thereof remain their sole responsibility.

The suitability and use of these drawings for any particular structure is the responsibility of the Building Designer in accordance with ANSI/TPI 1 Chapter 2. The Building Designer is responsible for determining that the dimensions and loads for each truss component match those required by the plans and by the actual use of the individual component, and for ascertaining that the loads shown on the drawings meet or exceed applicable building code requirements and any additional factors required in the particular application. Truss components using metal connector plates with integral teeth shall not be placed in environments that will cause the moisture content of the wood in which plates are embedded to exceed 19% and/or cause corrosion of connector plates and other metal fasteners.

The Truss Design Engineer shall not be responsible for items beyond the specific scope of the agreed contracted work set forth herein, including but not limited to: verifying the dimensions of the truss component, calculation of any of the truss component design loads, inspection of the truss components before or after installation, the design of temporary or permanent bracing and their attachment required in the roof and/or floor systems, the design of diaphragms or shear walls, the design of load transfer connections to and from diaphragms and shear walls, the design of load transfer to the foundation, the design of connections for truss components to their bearing supports, the design of the bearing supports, installation of the truss components, observation of the truss component installation process, review of truss assembly procedures, sequencing of the truss component installation, construction means and methods, site and/or worker safety in the installation of the truss components and/or its connections.

This document may be a high quality facsimile of the original engineering document which is a digitally signed electronic file with third party authentication. A wet or embossed seal copy of this engineering document is available upon request.

Temporary Lateral Restraint and Bracing:

Temporary lateral restraint and diagonal bracing shall be installed according to the provisions of BCSI chapters B1, B2, B7 and/or B10 (Building Component Safety Information, by TPI and SBCA), or as specified by the Building Designer or other Registered Design Professional. The required locations for lateral restraint and/or bracing depicted on these drawings are only for the permanent lateral support of the truss members to reduce buckling lengths, and do not apply to and may not be relied upon for the temporary stability of the truss components during their installation.

Permanent Lateral Restraint and Bracing:

The required locations for lateral restraint or bracing depicted on these drawings are for the permanent lateral support of the truss members to reduce buckling lengths. Permanent lateral support shall be installed according to the provisions of BCSI chapters B3, B7 and/or B10, or as specified by the Building Designer or other Registered Design Professional. These drawings do not depict or specify installation/erection bracing, wind bracing, portal bracing or similar building stability bracing which are parts of the overall building design to be specified, designed and detailed by the Building Designer.

Connector Plate Information:

Alpine connector plates are made of ASTM A653 or ASTM A1063 galvanized steel with the following designations, gauges and grades: W=Wave, 20ga, grade 40; H=High Strength, 20ga, grade 60; S=Super Strength, 18ga, grade 60. Information on model code compliance is contained in the ICC Evaluation Service report ESR-1118, available on-line at www.icc-es.org.

Fire Retardant Treated Lumber:

Fire retardant treated lumber must be properly re-dried and maintained below 19% or less moisture level through all stages of construction and usage. Fire retardant treated lumber may be more brittle than untreated lumber. Special handling care must be taken to prevent breakage during all handling activities.

General Notes (continued)

Key to Terms:

Information provided on drawings reflects a summary of the pertinent information required for the truss design. Detailed information on load cases, reactions, member lengths, forces and members requiring permanent lateral support may be found in calculation sheets available upon written request.

BCDL = Bottom Chord standard design Dead Load in pounds per square foot.

BCLL = Bottom Chord standard design Live Load in pounds per square foot.

CL = Certified lumber.

Des Ld = total of TCLL, TCDL, BCLL and BCDL Design Load in pounds per square foot.

FRT = Fire Retardant Treated lumber.

FRT-DB = D-Blaze Fire Retardant Treated lumber.

FRT-DC = Dricon Fire Retardant Treated lumber.

FRT-FP = FirePRO Fire Retardant Treated lumber.

FRT-FL = FlamePRO Fire Retardant Treated lumber.

FRT-FT = FlameTech Fire Retardant Treated lumber.

FRT-PG = PYRO-GUARD Fire Retardant Treated lumber.

g = green lumber.

HORZ(LL) = maximum Horizontal panel point deflection due to Live Load, in inches.

HORZ(TL) = maximum Horizontal panel point long term deflection in inches, due to Total Load, including creep adjustment.

HPL = additional Horizontal Load added to a truss Piece in pounds per linear foot or pounds.

Ic = Incised lumber.

FJ = Finger Jointed lumber.

L/# = user specified divisor for limiting span/deflection ratio for evaluation of actual L/defl value.

L/defl = ratio of Length between bearings, in inches, divided by the vertical Deflection due to creep, in inches, at the referenced panel point. Reported as 999 if greater than or equal to 999.

Loc = Location, starting location of left end of bearing or panel point (joint) location of deflection.

Max BC CSI = Maximum bending and axial Combined Stress Index for Bottom Chords for of all load cases.

Max TC CSI = Maximum bending and axial Combined Stress Index for Top Chords for of all load cases.

Max Web CSI = Maximum bending and axial Combined Stress Index for Webs for of all load cases.

NCBCLL = Non-Concurrent Bottom Chord design Live Load in pounds per square foot.

PL = additional Load applied at a user specified angle on a truss Piece in pounds per linear foot or pounds.

PLB = additional vertical load added to a Bottom chord Piece of a truss in pounds per linear foot or pounds

PLT = additional vertical load added to a Top chord Piece of a truss in pounds per linear foot or pounds.

PP = Panel Point.

R = maximum downward design Reaction, in pounds, from all specified gravity load cases, at the indicated location (Loc).

-R = maximum upward design Reaction, in pounds, from all specified gravity load cases, at the identified location (Loc).

Rh = maximum horizontal design Reaction in either direction, in pounds, from all specified gravity load cases, at the indicated location (Loc).

RL = maximum horizontal design Reaction in either direction, in pounds, from all specified non-gravity (wind or seismic) load cases, at the indicated location (Loc).

Rw = maximum downward design Reaction, in pounds, from all specified non-gravity (wind or seismic) load cases, at the identified location (Loc).

TCDL = Top Chord standard design Dead Load in pounds per square foot.

TCLL = Top Chord standard design Live Load in pounds per square foot.

U = maximum Upward design reaction, in pounds, from all specified non-gravity (wind or seismic) load cases, at the indicated location (Loc).

VERT(CL) = maximum Vertical panel point deflection in inches due to Live Load and Creep Component of Dead Load in inches.

VERT(CTL) = maximum Vertical panel point deflection ratios due to Live Load and Creep Component of Dead Load, and maximum long term Vertical panel point deflection in inches due to Total load, including creep adjustment.

VERT(LL) = maximum Vertical panel point deflection in inches due to Live Load.

VERT(TL) = maximum Vertical panel point long term deflection in inches due to Total load, including creep adjustment.

W = Width of non-hanger bearing, in inches.

Refer to ASCE-7 for Wind and Seismic abbreviations.

Uppercase Acronyms not explained above are as defined in TPI 1.

References:

1. AWC: American Wood Council; 222 Catoclin Circle SE, Suite 201; Leesburg, VA 20175; www.awc.org.
2. ICC: International Code Council; www.iccsafe.org.
3. Alpine, a division of ITW Building Components Group Inc.: 514 Earth City Expressway, Suite 242, Earth City, MO 63045; www.alpineitw.com.
4. TPI: Truss Plate Institute, 2670 Crain Highway, Suite 203, Waldorf, MD 20601; www.tpinst.org.
5. SBCA: Wood Truss Council of America, 6300 Enterprise Lane, Madison, WI 53719; www.sbcacomponents.com.

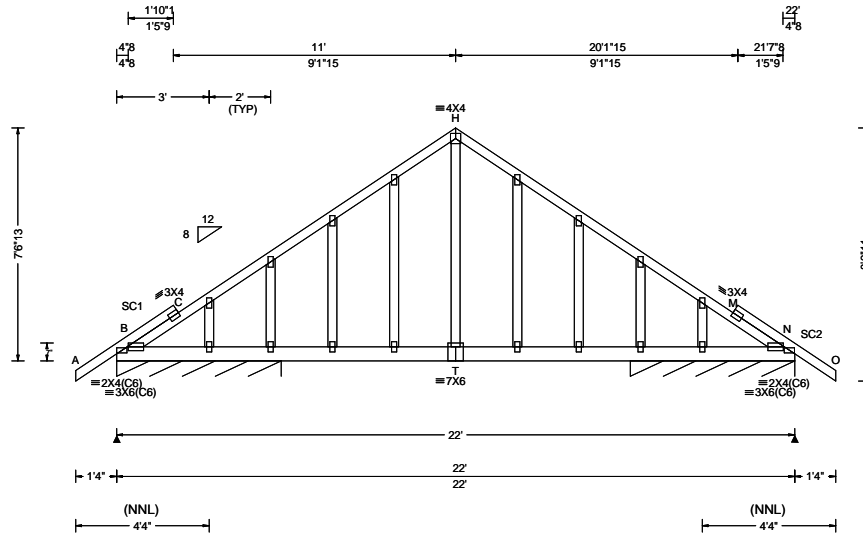

Loading Criteria (psf) TCLL: 20.00 TCDL: 10.00 BCLL: 0.00 BCDL: 10.00 Des Ld: 40.00 NCBCLL: 10.00 Soffit: 2.00 Load Duration: 1.25 Spacing: 24.0 "	Wind Criteria Wind Std: ASCE 7-10 Speed: 130 mph Enclosure: Closed Risk Category: II EXP: C Kzt: NA Mean Height: 15.00 ft TCDL: 5.0 psf BCDL: 5.0 psf MWFRS Parallel Dist: 0 to h/2 C&C Dist a: 3.00 ft Loc. from endwall: Any GCpi: 0.18 Wind Duration: 1.60	Snow Criteria (Pg,Pf in PSF) Pg: NA Ct: NA CAT: NA Pf: NA Ce: NA Lu: NA Cs: NA Snow Duration: NA Building Code: FBC 2017 RES TPI Std: 2014 Rep Fac: Varies by Ld Case FT/RT:20(0)/10(0) Plate Type(s): WAVE	Defl/CSI Criteria PP Deflection in loc L/defl L/# VERT(LL): 0.022 G 999 240 VERT(CL): 0.045 G 999 180 HORZ(LL): 0.009 G - - HORZ(TL): 0.018 G - - Creep Factor: 2.0 Max TC CSI: 0.173 Max BC CSI: 0.128 Max Web CSI: 0.164 VIEW Ver: 21.01.01A.0521.20	▲ Maximum Reactions (lbs), or *=PLF Gravity Non-Gravity Loc R+ / R- / Rh / Rw / U / RL B* 214 /- /- /119 /37 /9 N* 214 /- /- /119 /37 /- Wind reactions based on MWFRS B Brg Wid = 64.0 Min Req = - N Brg Wid = 64.0 Min Req = - Bearings B & Q are a rigid surface. Members not listed have forces less than 375# Maximum Top Chord Forces Per Ply (lbs) Chords Tens.Comp. Chords Tens. Comp. B - C 98 -431 H - M 114 -631 C - H 114 -631 M - N 98 -431
--	---	---	---	---

Lumber
Top chord: 2x4 SP #2;
Bot chord: 2x6 SP 2400f-2.0E;
Webs: 2x4 SP #3;
Stack Chord: SC1 2x4 SP #2;
Stack Chord: SC2 2x4 SP #2;

Special Loads
----- (Lumber Dur.Fac.=1.25 / Plate Dur.Fac.=1.25)
TC: From 64 plf at -1.33 to 64 plf at 23.33
BC: From 5 plf at -1.33 to 5 plf at 0.00
BC: From 20 plf at 0.00 to 20 plf at 22.00
BC: From 5 plf at 22.00 to 5 plf at 23.33
BC: 50 lb Conc. Load at 7.06, 9.06, 10.94, 12.94
14.94

Additional Notes
See DWGS A14015ENC101014 & GBLLETIN0118 for gable wind bracing and other requirements.
Stacked top chord must NOT be notched or cut in area (NNL). Dropped top chord braced at 24" oc intervals. Attach stacked top chord (SC) to dropped top chord in notchable area using 3x4 tie-plates 24" oc. Center plate on stacked/dropped chord interface, plate length perpendicular to chord length. Splice top chord in notchable area using 3x6.
The overall height of this truss excluding overhang is 7-6-13.

Maximum Bot Chord Forces Per Ply (lbs)
Chords Tens.Comp. Chords Tens. Comp.
B - T 493 -86 T - N 494 -86

Maximum Gable Forces Per Ply (lbs)
Gables Tens.Comp.
H - T 432 -48

Plating Notes
All plates are 2X4 except as noted.

Wind
Wind loads based on MWFRS with additional C&C member design.
Uplifts based on an elevation at or above 1000 ft.

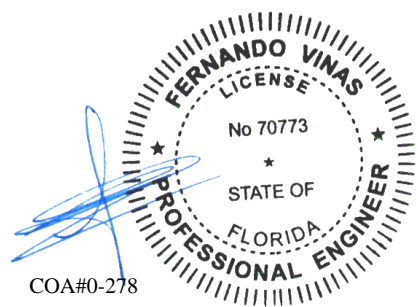

COA#0-278
02/28/2022

****WARNING** READ AND FOLLOW ALL NOTES ON THIS DRAWING!**
****IMPORTANT** FURNISH THIS DRAWING TO ALL CONTRACTORS INCLUDING THE INSTALLERS**
Trusses require extreme care in fabricating, handling, shipping, installing and bracing. Refer to and follow the latest edition of BCSI (Building Component Safety Information, by TPI and SBCA) for safety practices prior to performing these functions. Installers shall provide temporary bracing per BCSI. Unless noted otherwise, top chord shall have properly attached structural sheathing and bottom chord shall have a properly attached rigid ceiling. Locations shown for permanent lateral restraint of webs shall have bracing installed per BCSI sections B3, B7, or B10, as applicable. Apply plates to each face of truss and position as shown above and on the Joint Details, unless noted otherwise. Refer to drawings 160A-Z for standard plate positions. Refer to job's General Notes page for additional information.
Alpine, a division of ITW Building Components Group Inc. shall not be responsible for any deviation from this drawing, any failure to build the truss in conformance with ANSI/TPI 1, or for handling, shipping, installation and bracing of trusses. A seal on this drawing or cover page listing this drawing, indicates acceptance of professional engineering responsibility solely for the design shown. The suitability and use of this drawing for any structure is the responsibility of the Building Designer per ANSI/TPI 1 Sec.2.
For more information see these web sites: Alpine: alpineitw.com; TPI: tpinst.org; SBCA: sbccomponents.com; ICC: iccsafe.org; AWC: awc.org



SEQN: 647510 FROM: CDM	COMN Ply: 1 Qty: 15	Job Number: 22-6970 Jordan - Lancaster Model Truss Label: A02	Cust: R 215 JRef: 1Xdd2150013 T8 DrwNo: 059.22.1338.46397 GA / FV 02/28/2022
---------------------------	---------------------------	---	--

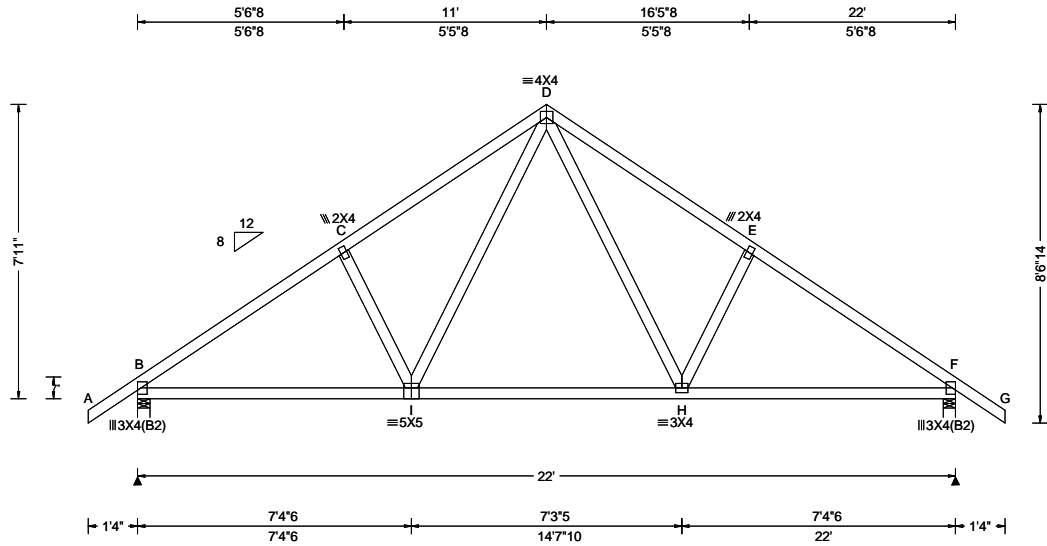

Loading Criteria (psf) TCCL: 20.00 TCDL: 10.00 BCLL: 0.00 BCDL: 10.00 Des Ld: 40.00 NCBCLL: 10.00 Soffit: 2.00 Load Duration: 1.25 Spacing: 24.0 "	Wind Criteria Wind Std: ASCE 7-10 Speed: 130 mph Enclosure: Closed Risk Category: II EXP: C Kzt: NA Mean Height: 15.00 ft TCDL: 5.0 psf BCDL: 5.0 psf MWFRS Parallel Dist: 0 to h/2 C&C Dist a: 3.00 ft Loc. from endwall: not in 4.50 ft GCp: 0.18 Wind Duration: 1.60	Snow Criteria (Pg,Pf in PSF) Pg: NA Ct: NA CAT: NA Pf: NA Ce: NA Lu: NA Cs: NA Snow Duration: NA Building Code: FBC 2017 RES TPI Std: 2014 Rep Fac: Yes FT/RT:20(0)/10(0) Plate Type(s): WAVE	Defl/CSI Criteria PP Deflection in loc L/def L/# VERT(LL): 0.054 H 999 240 VERT(CL): 0.104 H 999 180 HORZ(LL): 0.029 F - - HORZ(TL): 0.056 F - - Creep Factor: 2.0 Max TC CSI: 0.484 Max BC CSI: 0.631 Max Web CSI: 0.194 VIEW Ver: 21.01.01A.0521.20	▲ Maximum Reactions (lbs) Gravity Non-Gravity Loc R+ / R- / Rh / Rw / U / RL					
				B 1085 /- /- /622 /167 /250 F 1085 /- /- /622 /167 /- Wind reactions based on MWFRS B Brg Wid = 4.0 Min Req = 1.5 F Brg Wid = 4.0 Min Req = 1.5 Bearings B & F are a rigid surface. Members not listed have forces less than 375# Maximum Top Chord Forces Per Ply (lbs) Chords Tens.Comp. Chords Tens. Comp. B - C 262 - 1407 D - E 319 - 1252 C - D 318 - 1251 E - F 263 - 1408 Maximum Bot Chord Forces Per Ply (lbs) Chords Tens.Comp. Chords Tens. Comp. B - I 1081 - 108 H - F 1081 - 120 I - H 744 - 34 Maximum Web Forces Per Ply (lbs) Webs Tens.Comp. Webs Tens. Comp. I - D 506 - 128 D - H 509 - 127					

Lumber

Top chord: 2x4 SP #2;
 Bot chord: 2x4 SP #2;
 Webs: 2x4 SP #3;

Loading

Truss passed check for 20 psf additional bottom chord live load in areas with 42"-high x 24"-wide clearance.

Wind

Wind loads based on MWFRS with additional C&C member design.
 Uplifts based on an elevation at or above 1000 ft.

Additional Notes

The overall height of this truss excluding overhang is 7-11-0.

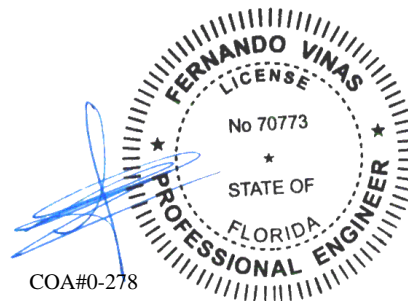

COA#0-278

02/28/2022

****WARNING** READ AND FOLLOW ALL NOTES ON THIS DRAWING!**
****IMPORTANT** FURNISH THIS DRAWING TO ALL CONTRACTORS INCLUDING THE INSTALLERS**
 Trusses require extreme care in fabricating, handling, shipping, installing and bracing. Refer to and follow the latest edition of BCSI (Building Component Safety Information, by TPI and SBCA) for safety practices prior to performing these functions. Installers shall provide temporary bracing per BCSI. Unless noted otherwise, top chord shall have properly attached structural sheathing and bottom chord shall have a properly attached rigid ceiling. Locations shown for permanent lateral restraint of webs shall have bracing installed per BCSI sections B3, B7, or B10, as applicable. Apply plates to each face of truss and position as shown above and on the Joint Details, unless noted otherwise. Refer to drawings 160A-Z for standard plate positions. Refer to job's General Notes page for additional information.
 Alpine, a division of ITW Building Components Group Inc. shall not be responsible for any deviation from this drawing, any failure to build the truss in conformance with ANSI/TPI 1, or for handling, shipping, installation and bracing of trusses. A seal on this drawing or cover page listing this drawing, indicates acceptance of professional engineering responsibility solely for the design shown. The suitability and use of this drawing for any structure is the responsibility of the Building Designer per ANSI/TPI 1 Sec.2.
 For more information see these web sites: Alpine: alpineitw.com; TPI: tpinst.org; SBCA: sbccomponents.com; ICC: iccsafe.org; AWC: awc.org



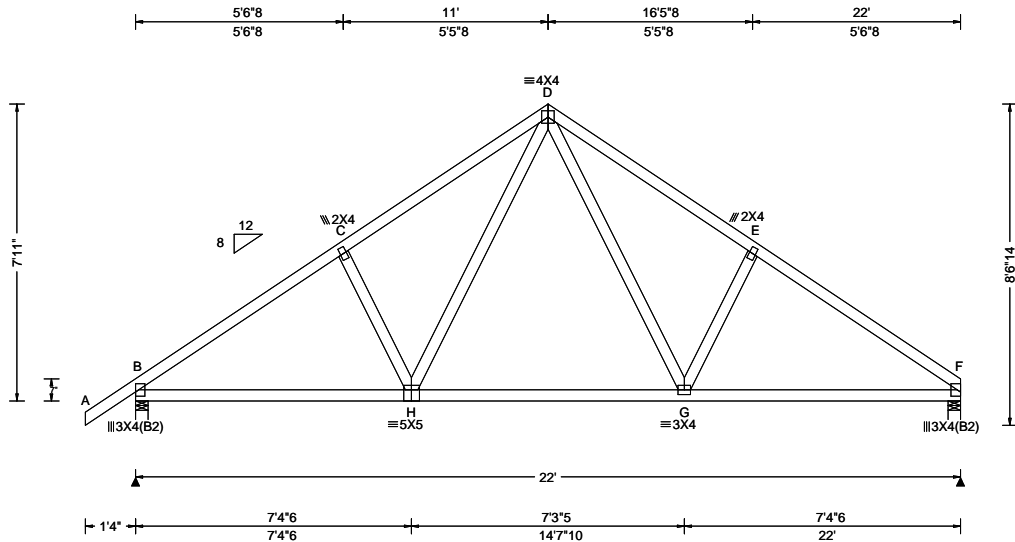

Loading Criteria (psf)	Wind Criteria	Snow Criteria (Pg,Pf in PSF)	Def/CSI Criteria	▲ Maximum Reactions (lbs)
TCLL: 20.00 TCDL: 10.00 BCLL: 0.00 BCDL: 10.00 Des Ld: 40.00 NCBCLL: 10.00 Soffit: 2.00 Load Duration: 1.25 Spacing: 24.0 "	Wind Std: ASCE 7-10 Speed: 130 mph Enclosure: Closed Risk Category: II EXP: C Kzt: NA Mean Height: 15.00 ft TCDL: 5.0 psf BCDL: 5.0 psf MWFRS Parallel Dist: h to 2h C&C Dist a: 3.00 ft Loc. from endwall: not in 9.00 ft GCpi: 0.18 Wind Duration: 1.60	Pg: NA Ct: NA CAT: NA Pf: NA Ce: NA Lu: NA Cs: NA Snow Duration: NA	PP Deflection in loc L/defl L/# VERT(LL): 0.053 H 999 240 VERT(CL): 0.102 H 999 180 HORZ(LL): 0.027 G - - HORZ(TL): 0.052 G - - Creep Factor: 2.0 Max TC CSI: 0.483 Max BC CSI: 0.627 Max Web CSI: 0.200 VIEW Ver: 19.02.02B.0122.15	Gravity Loc R+ / R- / Rh / Rw / U / RL Non-Gravity B 1088 /- /- /622 /11 /233 F 990 /- /- /542 /5 /- Wind reactions based on MWFRS B Brg Width = 4.0 Min Req = 1.5 F Brg Width = 4.0 Min Req = 1.5 Bearings B & F are a rigid surface. Members not listed have forces less than 375# Maximum Top Chord Forces Per Ply (lbs) Chords Tens.Comp. Chords Tens. Comp. B - C 263 -1412 D - E 338 -1267 C - D 321 -1256 E - F 279 -1421
		Code / Misc Criteria Bldg Code: FBC 2017 RES TPI Std: 2014 Rep Fac: Yes FT/RT:20(0)/10(0) Plate Type(s): WAVE		Maximum Bot Chord Forces Per Ply (lbs) Chords Tens.Comp. Chords Tens. Comp. B - H 1085 -153 G - F 1097 -156 H - G 748 -29
				Maximum Web Forces Per Ply (lbs) Webs Tens.Comp. Webs Tens. Comp. H - D 506 -126 D - G 524 -132

Lumber

Top chord: 2x4 SP #2;
Bot chord: 2x4 SP #2;
Webs: 2x4 SP #3;

Loading

Truss passed check for 20 psf additional bottom chord live load in areas with 42"-high x 24"-wide clearance.

Wind

Wind loads based on MWFRS with additional C&C member design.
Uplifts based on an elevation at or above 1000 ft.

Additional Notes

Refer to General Notes for additional information
The overall height of this truss excluding overhang is 7-11-0.

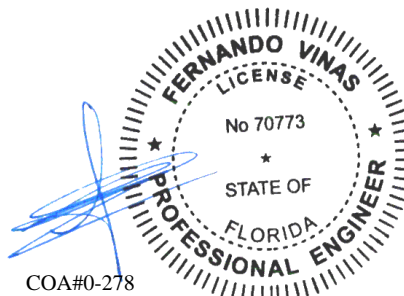

02/28/2022

****WARNING** READ AND FOLLOW ALL NOTES ON THIS DRAWING!**
****IMPORTANT** FURNISH THIS DRAWING TO ALL CONTRACTORS INCLUDING THE INSTALLERS**
Trusses require extreme care in fabricating, handling, shipping, installing and bracing. Refer to and follow the latest edition of BCSI (Building Component Safety Information, by TPI and SBCA) for safety practices prior to performing these functions. Installers shall provide temporary bracing per BCSI. Unless noted otherwise, top chord shall have properly attached structural sheathing and bottom chord shall have a properly attached rigid ceiling. Locations shown for permanent lateral restraint of webs shall have bracing installed per BCSI sections B3, B7, or B10, as applicable. Apply plates to each face of truss and position as shown above and on the Joint Details, unless noted otherwise. Refer to drawings 160A-Z for standard plate positions.

Alpine, a division of ITW Building Components Group Inc. shall not be responsible for any deviation from this drawing, any failure to build the truss in conformance with ANSI/TPI 1, or for handling, shipping, installation and bracing of trusses. A seal on this drawing or cover page listing this drawing, indicates acceptance of professional engineering responsibility solely for the design shown. The suitability and use of this drawing for any structure is the responsibility of the Building Designer per ANSI/TPI 1 Sec.2.

For more information see this job's general notes page and these web sites: ALPINE: www.alpineitw.com; TPI: www.tpinet.org; SBCA: www.sbcindustry.com; ICC: www.iccsafe.org



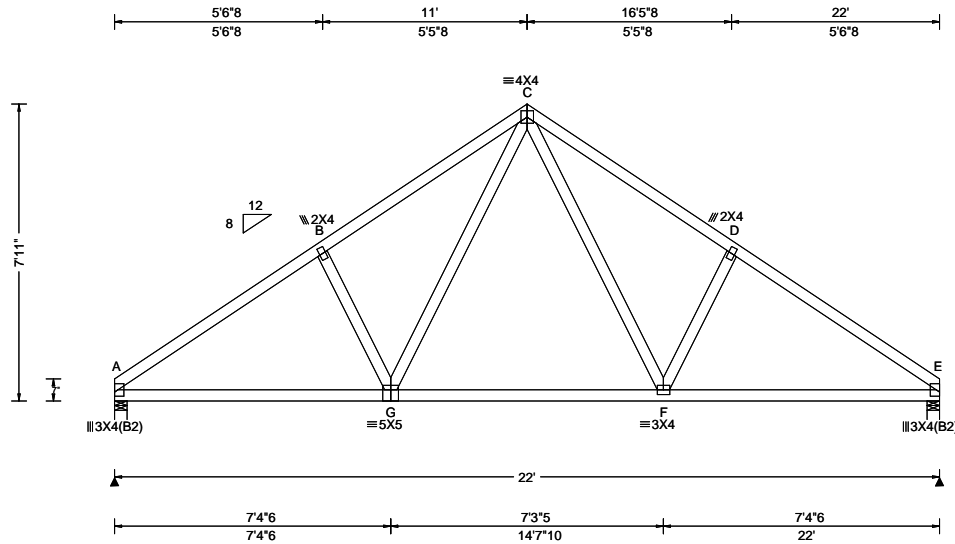

Loading Criteria (psf)	Wind Criteria	Snow Criteria (Pg,Pf in PSF)	Defl/CSI Criteria	▲ Maximum Reactions (lbs)
TCLL: 20.00 TCDL: 10.00 BCLL: 0.00 BCDL: 10.00 Des Ld: 40.00 NCBCLL: 10.00 Soffit: 2.00 Load Duration: 1.25 Spacing: 24.0 "	Wind Std: ASCE 7-10 Speed: 130 mph Enclosure: Closed Risk Category: II EXP: C Kzt: NA Mean Height: 15.00 ft TCDL: 5.0 psf BCDL: 5.0 psf MWFRS Parallel Dist: h to 2h C&C Dist a: 3.00 ft Loc. from endwall: not in 9.00 ft GCpi: 0.18 Wind Duration: 1.60	Pg: NA Ct: NA CAT: NA Pf: NA Ce: NA Lu: NA Cs: NA Snow Duration: NA	PP Deflection in loc L/defl L/# VERT(LL): 0.040 F 999 240 VERT(CL): 0.083 F 999 180 HORZ(LL): 0.020 F - - HORZ(TL): 0.042 F - - Creep Factor: 2.0 Max TC CSI: 0.343 Max BC CSI: 0.613 Max Web CSI: 0.181	Gravity Loc R+ / R- / Rh / Rw / U / RL A 924 /- /- /542 /6 /203 E 924 /- /- /542 /6 /- Non-Gravity A Brg Width = 4.0 Min Req = 1.5 E Brg Width = 4.0 Min Req = 1.5 Bearings A & E are a rigid surface. Members not listed have forces less than 375# Maximum Top Chord Forces Per Ply (lbs) Chords Tens.Comp. Chords Tens. Comp. A - B 281 -1294 C - D 339 -1141 B - C 339 -1141 D - E 281 -1295
		Code / Misc Criteria Bldg Code: FBC 2017 RES TPI Std: 2014 Rep Fac: Yes FT/RT:20(0)/10(0) Plate Type(s): WAVE	VIEW Ver: 19.02.02B.0122.15	Maximum Bot Chord Forces Per Ply (lbs) Chords Tens.Comp. Chords Tens. Comp. A - G 995 -158 F - E 995 -158 G - F 676 -31
				Maximum Web Forces Per Ply (lbs) Webs Tens.Comp. Webs Tens. Comp. G - C 443 -132 C - F 445 -132

Lumber

Top chord: 2x4 SP #2;
Bot chord: 2x4 SP #2;
Webs: 2x4 SP #3;

Wind

Wind loads based on MWFRS with additional C&C member design.
Uplifts based on an elevation at or above 1000 ft.

Additional Notes

Refer to General Notes for additional information
The overall height of this truss excluding overhang is 7-11-0.

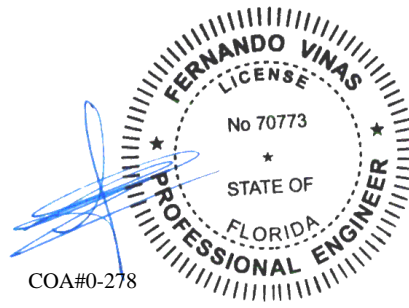

****WARNING** READ AND FOLLOW ALL NOTES ON THIS DRAWING!**
****IMPORTANT** FURNISH THIS DRAWING TO ALL CONTRACTORS INCLUDING THE INSTALLERS**
Trusses require extreme care in fabricating, handling, shipping, installing and bracing. Refer to and follow the latest edition of BCSI (Building Component Safety Information, by TPI and SBCA) for safety practices prior to performing these functions. Installers shall provide temporary bracing per BCSI. Unless noted otherwise, top chord shall have properly attached structural sheathing and bottom chord shall have a properly attached rigid ceiling. Locations shown for permanent lateral restraint of webs shall have bracing installed per BCSI sections B3, B7, or B10, as applicable. Apply plates to each face of truss and position as shown above and on the Joint Details, unless noted otherwise. Refer to drawings 160A-Z for standard plate positions.
Alpine, a division of ITW Building Components Group Inc. shall not be responsible for any deviation from this drawing, any failure to build the truss in conformance with ANSI/TPI 1, or for handling, shipping, installation and bracing of trusses. A seal on this drawing or cover page listing this drawing, indicates acceptance of professional engineering responsibility solely for the design shown. The suitability and use of this drawing for any structure is the responsibility of the Building Designer per ANSI/TPI 1 Sec.2.
For more information see this job's general notes page and these web sites: ALPINE: www.alpineitw.com; TPI: www.tpinst.org; SBCA: www.sbcindustry.com; ICC: www.iccsafe.org

6750 Forum Drive
 Suite 305
 Orlando FL, 32821

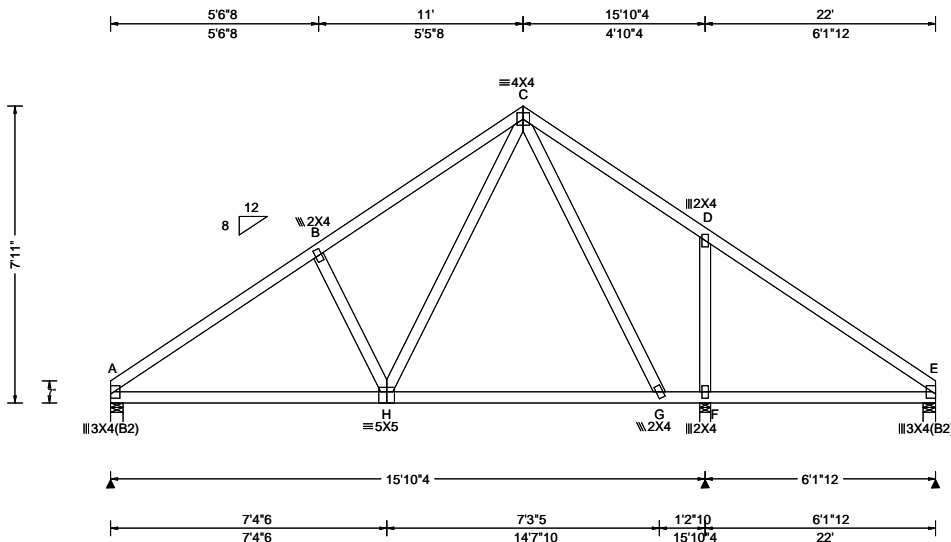

Loading Criteria (psf)	Wind Criteria	Snow Criteria (Pg,Pf in PSF)	Def/CSI Criteria	▲ Maximum Reactions (lbs)
TCLL: 20.00 TCDL: 10.00 BCLL: 0.00 BCDL: 10.00 Des Ld: 40.00 NCBCLL: 10.00 Soffit: 2.00 Load Duration: 1.25 Spacing: 24.0 "	Wind Std: ASCE 7-10 Speed: 130 mph Enclosure: Closed Risk Category: II EXP: C Kzt: NA Mean Height: 15.00 ft TCDL: 5.0 psf BCDL: 5.0 psf MWFRS Parallel Dist: h to 2h C&C Dist a: 3.00 ft Loc. from endwall: not in 9.00 ft GCpi: 0.18 Wind Duration: 1.60	Pg: NA Ct: NA CAT: NA Pf: NA Ce: NA Lu: NA Cs: NA Snow Duration: NA	PP Deflection in loc L/defl L/# VERT(LL): 0.037 H 999 240 VERT(CL): 0.079 H 999 180 HORZ(LL): 0.023 D - - HORZ(TL): 0.051 D - - Creep Factor: 2.0 Max TC CSI: 0.399 Max BC CSI: 0.630 Max Web CSI: 0.209 VIEW Ver: 19.02.02B.0122.15	Gravity Non-Gravity Loc R+ / R- / Rh / Rw / U / RL A 868 -/ - / - /506 -/ /203 F 474 -/ - / - /368 /76 -/ E 651 -/ - / - /369 -/ -/ Wind reactions based on MWFRS A Brg Width = 4.0 Min Req = 1.5 F Brg Width = 3.5 Min Req = 1.5 E Brg Width = 4.0 Min Req = 1.5 Bearings A, F, & E are a rigid surface. Members not listed have forces less than 375# Maximum Top Chord Forces Per Ply (lbs) Chords Tens.Comp. Chords Tens. Comp.

Lumber
Top chord: 2x4 SP #2;
Bot chord: 2x4 SP #2;
Webs: 2x4 SP #3;

Loading
Truss passed check for 20 psf additional bottom chord live load in areas with 42"-high x 24"-wide clearance.

Wind
Wind loads based on MWFRS with additional C&C member design.
Uplifts based on an elevation at or above 1000 ft.

Additional Notes
Refer to General Notes for additional information
The overall height of this truss excluding overhang is 7'-11-0.

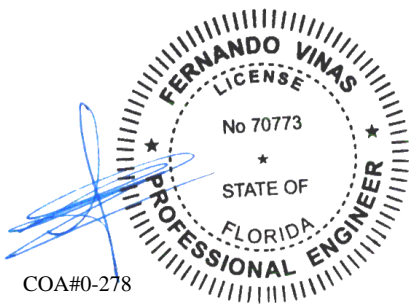

COA#0-278
02/28/2022

****WARNING** READ AND FOLLOW ALL NOTES ON THIS DRAWING!**
****IMPORTANT** FURNISH THIS DRAWING TO ALL CONTRACTORS INCLUDING THE INSTALLERS**
Trusses require extreme care in fabricating, handling, shipping, installing and bracing. Refer to and follow the latest edition of BCSI (Building Component Safety Information, by TPI and SBCA) for safety practices prior to performing these functions. Installers shall provide temporary bracing per BCSI. Unless noted otherwise, top chord shall have properly attached structural sheathing and bottom chord shall have a properly attached rigid ceiling. Locations shown for permanent lateral restraint of webs shall have bracing installed per BCSI sections B3, B7, or B10, as applicable. Apply plates to each face of truss and position as shown above and on the Joint Details, unless noted otherwise. Refer to drawings 160A-Z for standard plate positions.
Alpine, a division of ITW Building Components Group Inc. shall not be responsible for any deviation from this drawing, any failure to build the truss in conformance with ANSI/TPI 1, or for handling, shipping, installation and bracing of trusses. A seal on this drawing or cover page listing this drawing, indicates acceptance of professional engineering responsibility solely for the design shown. The suitability and use of this drawing for any structure is the responsibility of the Building Designer per ANSI/TPI 1 Sec.2.
For more information see this job's general notes page and these web sites: ALPINE: www.alpineitw.com; TPI: www.tpinet.org; SBCA: www.sbcindustry.com; ICC: www.iccsafe.org



2 Complete Trusses Required

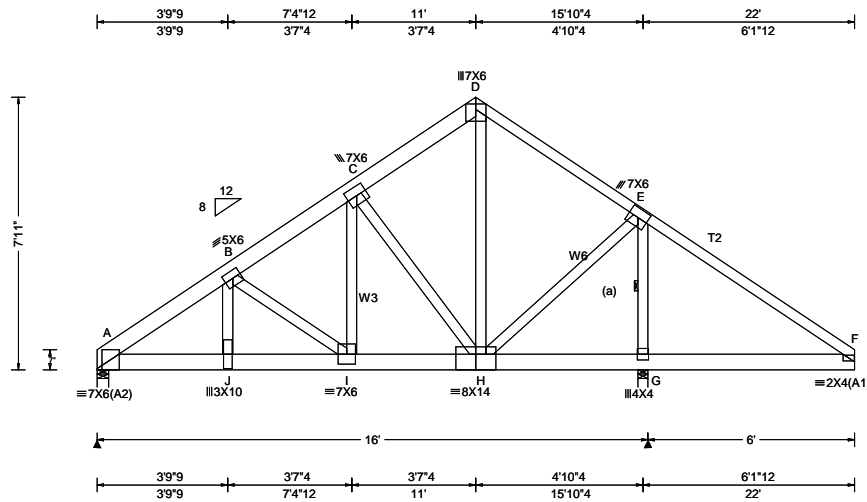

Loading Criteria (psf) TCLL: 20.00 TCDL: 10.00 BCLL: 0.00 BCDL: 10.00 Des Ld: 40.00 NCBCLL: 0.00 Soffit: 2.00 Load Duration: 1.25 Spacing: 24.0 "	Wind Criteria Wind Std: ASCE 7-10 Speed: 130 mph Enclosure: Closed Risk Category: II EXP: C Kzt: NA Mean Height: 15.00 ft TCDL: 5.0 psf BCDL: 5.0 psf MWFRS Parallel Dist: 0 to h/2 C&C Dist a: 3.00 ft Loc. from endwall: not in 9.00 ft GCp: 0.18 Wind Duration: 1.60	Snow Criteria (Pg,Pf in PSF) Pg: NA Ct: NA CAT: NA Pf: NA Ce: NA Lu: NA Cs: NA Snow Duration: NA Building Code: FBC 2017 RES TPI Std: 2014 Rep Fac: No FT/RT:20(0)/10(0) Plate Type(s): WAVE	Defl/CSI Criteria PP Deflection in loc L/defl L/# VERT(LL): 0.071 I 999 240 VERT(CL): 0.142 I 999 180 HORZ(LL): 0.028 B - - HORZ(TL): 0.055 B - - Creep Factor: 2.0 Max TC CSI: 0.276 Max BC CSI: 0.461 Max Web CSI: 0.961 VIEW Ver: 21.01.01A.0521.20	▲ Maximum Reactions (lbs) Gravity Non-Gravity Loc R+ / R- / Rh / Rw / U / RL A 7505 /- /- /- /1243 /- G 9034 /- /- /- /1369 /- Wind reactions based on MWFRS A Brg Wid = 4.0 Min Req = 3.1 G Brg Wid = 3.5 Min Req = 3.4 Bearings A & G are a rigid surface. Members not listed have forces less than 375# Maximum Top Chord Forces Per Ply (lbs) Chords Tens.Comp. Chords Tens. Comp. A - B 911 -5493 C - D 406 -2425 B - C 689 -4137 D - E 420 -2483
---	---	--	---	---

Lumber
Top chord: 2x6 SP 2400f-2.0E; T2 2x4 SP #2;
Bot chord: 2x6 SP 2400f-2.0E;
Webs: 2x4 SP #3; W3,W6 2x4 SP #2;

Additional Notes
The overall height of this truss excluding overhang is 7'-11".

Bracing
(a) Continuous lateral restraint equally spaced on member.

Nailnote
Nail Schedule: 0.128"x3", min. nails
Top Chord: 1 Row @ 12.00" o.c.
Bot Chord: 2 Rows @ 4.50" o.c. (Each Row)
Webs : 1 Row @ 4" o.c.
Use equal spacing between rows and stagger nails in each row to avoid splitting.

Special Loads
-----(Lumber Dur.Fac.=1.25 / Plate Dur.Fac.=1.25)
TC: From 64 plf at 0.00 to 64 plf at 22.00
BC: From 10 plf at 0.00 to 10 plf at 15.06
BC: From 20 plf at 15.06 to 20 plf at 22.00
BC: 1939 lb Conc. Load at 2.06, 4.06, 6.06, 8.06
10.06
BC: 1745 lb Conc. Load at 11.06, 13.06
BC: 1610 lb Conc. Load at 15.06

Wind
Wind loads and reactions based on MWFRS.
Right cantilever is exposed to wind
Uplifts based on an elevation at or above 1000 ft.

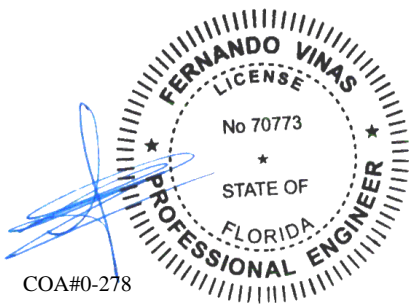

COA#0-278
02/28/2022

****WARNING** READ AND FOLLOW ALL NOTES ON THIS DRAWING!**
****IMPORTANT** FURNISH THIS DRAWING TO ALL CONTRACTORS INCLUDING THE INSTALLERS**
Trusses require extreme care in fabricating, handling, shipping, installing and bracing. Refer to and follow the latest edition of BCSI (Building Component Safety Information, by TPI and SBCA) for safety practices prior to performing these functions. Installers shall provide temporary bracing per BCSI. Unless noted otherwise, top chord shall have properly attached structural sheathing and bottom chord shall have a properly attached rigid ceiling. Locations shown for permanent lateral restraint of webs shall have bracing installed per BCSI sections B3, B7, or B10, as applicable. Apply plates to each face of truss and position as shown above and on the Joint Details, unless noted otherwise. Refer to drawings 160A-Z for standard plate positions. Refer to job's General Notes page for additional information.
Alpine, a division of ITW Building Components Group Inc. shall not be responsible for any deviation from this drawing, any failure to build the truss in conformance with ANSI/TPI 1, or for handling, shipping, installation and bracing of trusses. A seal on this drawing or cover page listing this drawing, indicates acceptance of professional engineering responsibility solely for the design shown. The suitability and use of this drawing for any structure is the responsibility of the Building Designer per ANSI/TPI 1 Sec.2.
For more information see these web sites: Alpine: alpineitw.com; TPI: tpinst.org; SBCA: sbccomponents.com; ICC: iccsafe.org; AWC: awc.org



SEQN: 593919 / FROM: CDM	GABL Ply: 1 Qty: 1	Job Number: 22-6970 Jordan - Lancaster Model Truss Label: B01	Cust: R215 JRef: 1Xdd2150013 T15 / DrwNo: 056.22.1250.50269 / YK 02/25/2022
-----------------------------	--------------------------	---	---

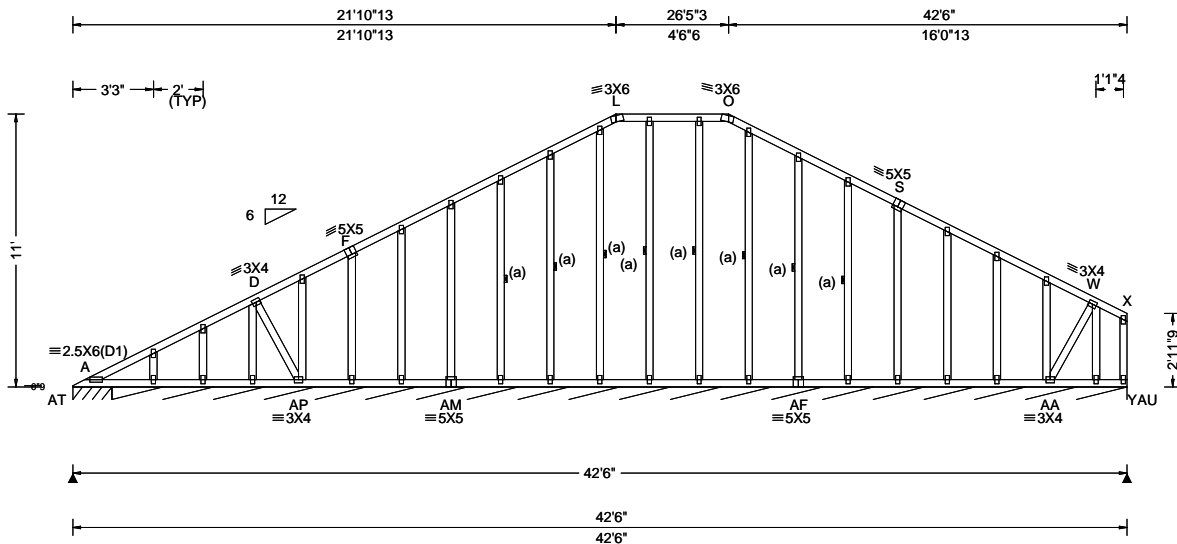

Loading Criteria (psf) TCLL: 20.00 TCDL: 10.00 BCLL: 0.00 BCDL: 10.00 Des Ld: 40.00 NCBCLL: 10.00 Soffit: 2.00 Load Duration: 1.25 Spacing: 24.0 "	Wind Criteria Wind Std: ASCE 7-10 Speed: 130 mph Enclosure: Closed Risk Category: II EXP: C Kzt: NA Mean Height: 15.00 ft TCDL: 5.0 psf BCDL: 5.0 psf MWFRS Parallel Dist: 0 to h/2 C&C Dist a: 4.25 ft Loc. from endwall: Any GCpi: 0.18 Wind Duration: 1.60	Snow Criteria (Pg,Pf in PSF) Pg: NA Ct: NA CAT: NA Pf: NA Ce: NA Lu: NA Cs: NA Snow Duration: NA Building Code: FBC 2017 RES TPI Std: 2014 Rep Fac: Yes FT/RT:20(0)/10(0) Plate Type(s): WAVE	Defl/CSI Criteria PP Deflection in loc L/defl L/# VERT(LL): 0.004 AS 999 240 VERT(CL): 0.008 AS 999 180 HORZ(LL): 0.005 U - - HORZ(TL): 0.007 S - - Creep Factor: 2.0 Max TC CSI: 0.096 Max BC CSI: 0.077 Max Web CSI: 0.132 VIEW Ver: 19.02.02B.0122.15	▲ Maximum Reactions (lbs), or * = PLF Gravity Non-Gravity Loc R+ / R- / Rh / Rw / U / RL AT*78 - / - / 83 / 30 / 170 AU*83 - / - / 47 / 15 / - Wind reactions based on MWFRS AT Brg Width = 19.0 Min Req = - AU Brg Width = 491 Min Req = - Bearings AT & A are a rigid surface. Members not listed have forces less than 375#
--	---	---	---	--

Lumber

Top chord: 2x4 SP #2;
Bot chord: 2x4 SP #2;
Webs: 2x4 SP #3;

Bracing

(a) Continuous lateral restraint equally spaced on member.

Plating Notes

All plates are 2X4 except as noted.

Wind

Wind loads based on MWFRS with additional C&C member design.

Right end vertical not exposed to wind pressure.

Uplifts based on an elevation at or above 1000 ft.

Additional Notes

See DWGS A14015ENC101014 & GBLLETIN0118 for gable wind bracing and other requirements.

The overall height of this truss excluding overhang is 11-0-0.

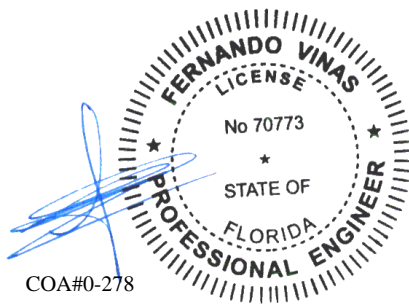

COA#0-278

02/28/2022

****WARNING** READ AND FOLLOW ALL NOTES ON THIS DRAWING!**
****IMPORTANT** FURNISH THIS DRAWING TO ALL CONTRACTORS INCLUDING THE INSTALLERS**
Trusses require extreme care in fabricating, handling, shipping, installing and bracing. Refer to and follow the latest edition of BCSI (Building Component Safety Information, by TPI and SBCA) for safety practices prior to performing these functions. Installers shall provide temporary bracing per BCSI. Unless noted otherwise, top chord shall have properly attached structural sheathing and bottom chord shall have a properly attached rigid ceiling. Locations shown for permanent lateral restraint of webs shall have bracing installed per BCSI sections B3, B7, or B10, as applicable. Apply plates to each face of truss and position as shown above and on the Joint Details, unless noted otherwise. Refer to drawings 160A-Z for standard plate positions. Refer to job's General Notes page for additional information.
Alpine, a division of ITW Building Components Group Inc. shall not be responsible for any deviation from this drawing, any failure to build the truss in conformance with ANSI/TPI 1, or for handling, shipping, installation and bracing of trusses. A seal on this drawing or cover page listing this drawing, indicates acceptance of professional engineering responsibility solely for the design shown. The suitability and use of this drawing for any structure is the responsibility of the Building Designer per ANSI/TPI 1 Sec.2.
For more information see these web sites: Alpine: www.alpineitw.com; TPI: www.tpinst.org; SBCA: www.sbcindustry.com; ICC: www.iccsafe.org



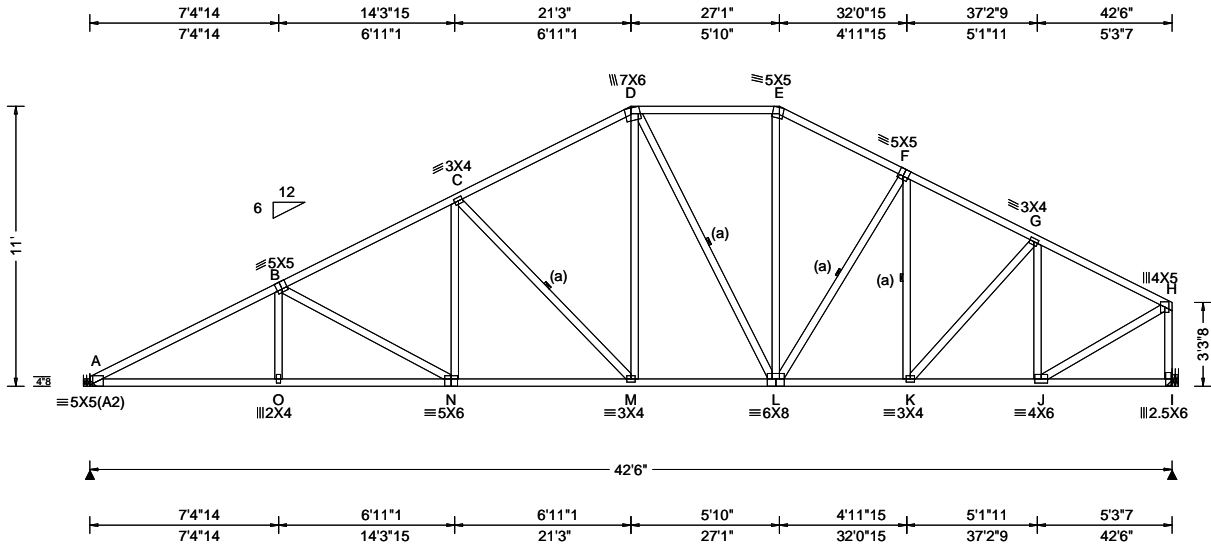

Loading Criteria (psf)	Wind Criteria	Snow Criteria (Pg,Pf in PSF)	Defl/CSI Criteria	▲ Maximum Reactions (lbs)
TCLL: 20.00 TCDL: 10.00 BCLL: 0.00 BCDL: 10.00 Des Ld: 40.00 NCBCLL: 10.00 Soffit: 2.00 Load Duration: 1.25 Spacing: 24.0 "	Wind Std: ASCE 7-10 Speed: 130 mph Enclosure: Closed Risk Category: II EXP: C Kzt: NA Mean Height: 15.00 ft TCDL: 5.0 psf BCDL: 5.0 psf MWFRS Parallel Dist: 0 to h/2 C&C Dist a: 4.25 ft Loc. from endwall: Any GCpi: 0.18 Wind Duration: 1.60	Pg: NA Ct: NA CAT: NA Pf: NA Ce: NA Lu: NA Cs: NA Snow Duration: NA Building Code: FBC 2017 RES TPI Std: 2014 Rep Fac: Yes FT/RT:20(0)/10(0) Plate Type(s): WAVE	PP Deflection in loc L/defl L/# VERT(LL): 0.207 N 999 240 VERT(CL): 0.389 N 999 180 HORZ(LL): 0.081 I - - HORZ(TL): 0.152 I - - Creep Factor: 2.0 Max TC CSI: 0.890 Max BC CSI: 0.979 Max Web CSI: 0.716 VIEW Ver: 19.02.02B.0122.15	Gravity Loc R+ / R- / Rh / Rw / U / RL A 1924 - / - / 1068 / 300 / 266 I 1939 - / - / 981 / 306 / - Non-Gravity Wind reactions based on MWFRS A Brg Width = - Min Req = - I Brg Width = - Min Req = - Members not listed have forces less than 375# Maximum Top Chord Forces Per Ply (lbs) Chords Tens.Comp. Chords Tens. Comp. A - B 1399 -3654 E - F 1010 -2151 B - C 1215 -3077 F - G 989 -2241 C - D 1048 -2371 G - H 786 -1883 D - E 965 -1872

Lumber

Top chord: 2x4 SP #2;
Bot chord: 2x4 SP #2;
Webs: 2x4 SP #3;

Bracing

(a) Continuous lateral restraint equally spaced on member.

Hangers / Ties

(J) Hanger Support Required, by others

Loading

Truss passed check for 20 psf additional bottom chord live load in areas with 42"-high x 24"-wide clearance.

Wind

Wind loads based on MWFRS with additional C&C member design.
Right end vertical not exposed to wind pressure.
Uplifts based on an elevation at or above 1000 ft.

Additional Notes

The overall height of this truss excluding overhang is 11-0-0.

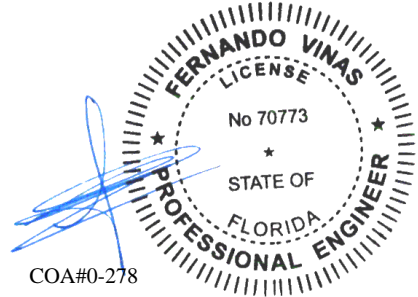

02/28/2022

****WARNING** READ AND FOLLOW ALL NOTES ON THIS DRAWING!**
****IMPORTANT** FURNISH THIS DRAWING TO ALL CONTRACTORS INCLUDING THE INSTALLERS**
Trusses require extreme care in fabricating, handling, shipping, installing and bracing. Refer to and follow the latest edition of BCSI (Building Component Safety Information, by TPI and SBCA) for safety practices prior to performing these functions. Installers shall provide temporary bracing per BCSI. Unless noted otherwise, top chord shall have properly attached structural sheathing and bottom chord shall have a properly attached rigid ceiling. Locations shown for permanent lateral restraint of webs shall have bracing installed per BCSI sections B3, B7, or B10, as applicable. Apply plates to each face of truss and position as shown above and on the Joint Details, unless noted otherwise. Refer to drawings 160A-Z for standard plate positions. Refer to job's General Notes page for additional information.
Alpine, a division of ITW Building Components Group Inc. shall not be responsible for any deviation from this drawing, any failure to build the truss in conformance with ANSI/TPI 1, or for handling, shipping, installation and bracing of trusses. A seal on this drawing or cover page listing this drawing, indicates acceptance of professional engineering responsibility solely for the design shown. The suitability and use of this drawing for any structure is the responsibility of the Building Designer per ANSI/TPI 1 Sec.2.
For more information see these web sites: Alpine: www.alpineitw.com; TPI: www.tpinst.org; SBCA: www.sbcindustry.com; ICC: www.iccsafe.org



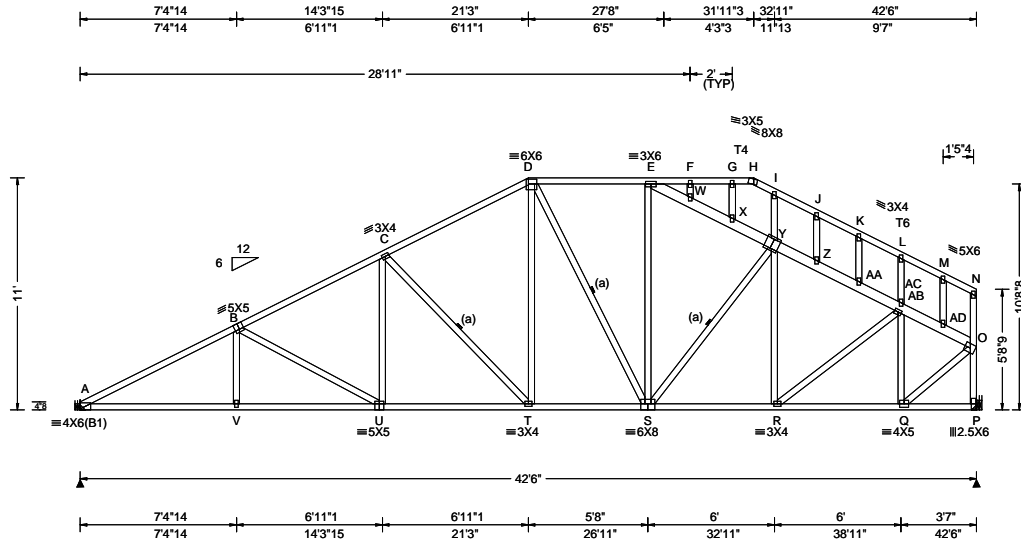

Loading Criteria (psf) TCLL: 20.00 TCDL: 10.00 BCLL: 0.00 BCDL: 10.00 Des Ld: 40.00 NCBCLL: 10.00 Soffit: 2.00 Load Duration: 1.25 Spacing: 24.0 "	Wind Criteria Wind Std: ASCE 7-10 Speed: 130 mph Enclosure: Closed Risk Category: II EXP: C Kzt: NA Mean Height: 15.00 ft TCDL: 5.0 psf BCDL: 5.0 psf MWFRS Parallel Dist: h/2 to h C&C Dist a: 4.25 ft Loc. from endwall: not in 6.50 ft GCpi: 0.18 Wind Duration: 1.60	Snow Criteria (Pg,Pf in PSF) Pg: NA Ct: NA CAT: NA Pf: NA Ce: NA Lu: NA Cs: NA Snow Duration: NA Building Code: FBC 2017 RES TPI Std: 2014 Rep Fac: Yes FT/RT:20(0)/10(0) Plate Type(s): WAVE	Defl/CSI Criteria PP Deflection in loc L/defl L/# VERT(LL): 0.159 U 999 240 VERT(CL): 0.328 U 999 180 HORZ(LL): 0.066 Q - - HORZ(TL): 0.136 Q - - Creep Factor: 2.0 Max TC CSI: 0.808 Max BC CSI: 0.850 Max Web CSI: 0.719 VIEW Ver: 19.02.02B.0122.15	▲ Maximum Reactions (lbs) Gravity Loc R+ / R- / Rh / Rw / U / RL Non-Gravity A 1755 - / - / 1089 / 295 / 246 P 1745 - / - / 928 / 317 - / - Wind reactions based on MWFRS A Brg Width = - Min Req = - P Brg Width = - Min Req = - Members not listed have forces less than 375# Maximum Top Chord Forces Per Ply (lbs) Chords Tens.Comp. Chords Tens. Comp. A - B 769 -3298 C - D 629 -2059 B - C 698 -2700 D - E 577 -1623 Maximum Bot Chord Forces Per Ply (lbs) Chords Tens.Comp. Chords Tens. Comp. A - V 2862 -756 T - S 1751 -429 V - U 2859 -756 S - R 1724 -408 U - T 2316 -605 R - Q 1249 -333 Maximum Web Forces Per Ply (lbs) Webs Tens.Comp. Webs Tens. Comp. B - U 215 -609 R - AC 602 -109 U - C 508 -81 Z - AA 469 -1915 C - T 257 -825 AA-AB 486 -1953 D - T 728 -166 AB-AC 518 -2011 S - E 505 -84 AC- Q 279 -891 E - W 449 -1838 AC-AD 346 -1332 W - X 462 -1839 Q - O 1577 -415 X - Y 466 -1888 AD- O 374 -1369 Y - Z 443 -1878 O - P 486 -1722
--	--	---	---	---

Lumber
Top chord: 2x4 SP #2; T4,T6 2x6 SP 2400f-2.0E;
Bot chord: 2x4 SP #2;
Webs: 2x4 SP #3;

Bracing
(a) Continuous lateral restraint equally spaced on member.

Plating Notes
All plates are 2X4 except as noted.

Hangers / Ties
(J) Hanger Support Required, by others

Wind
Wind loads based on MWFRS with additional C&C member design.
Right end vertical not exposed to wind pressure.
Uplifts based on an elevation at or above 1000 ft.

Additional Notes
The overall height of this truss excluding overhang is 11'-0".

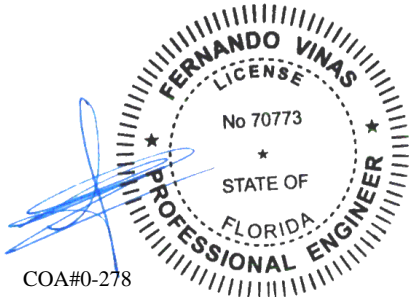

COA#0-278
02/28/2022

****WARNING** READ AND FOLLOW ALL NOTES ON THIS DRAWING!**
****IMPORTANT** FURNISH THIS DRAWING TO ALL CONTRACTORS INCLUDING THE INSTALLERS**

Trusses require extreme care in fabricating, handling, shipping, installing and bracing. Refer to and follow the latest edition of BCSI (Building Component Safety Information, by TPI and SBCA) for safety practices prior to performing these functions. Installers shall provide temporary bracing per BCSI. Unless noted otherwise, top chord shall have properly attached structural sheathing and bottom chord shall have a properly attached rigid ceiling. Locations shown for permanent lateral restraint of webs shall have bracing installed per BCSI sections B3, B7, or B10, as applicable. Apply plates to each face of truss and position as shown above and on the Joint Details, unless noted otherwise. Refer to drawings 160A-Z for standard plate positions. Refer to job's General Notes page for additional information.

Alpine, a division of ITW Building Components Group Inc. shall not be responsible for any deviation from this drawing, any failure to build the truss in conformance with ANSI/TPI 1, or for handling, shipping, installation and bracing of trusses. A seal on this drawing or cover page listing this drawing, indicates acceptance of professional engineering responsibility solely for the design shown. The suitability and use of this drawing for any structure is the responsibility of the Building Designer per ANSI/TPI 1 Sec.2.

For more information see these web sites: Alpine: www.alpineitw.com; TPI: www.tpinst.org; SBCA: www.sbcindustry.com; ICC: www.iccsafe.org



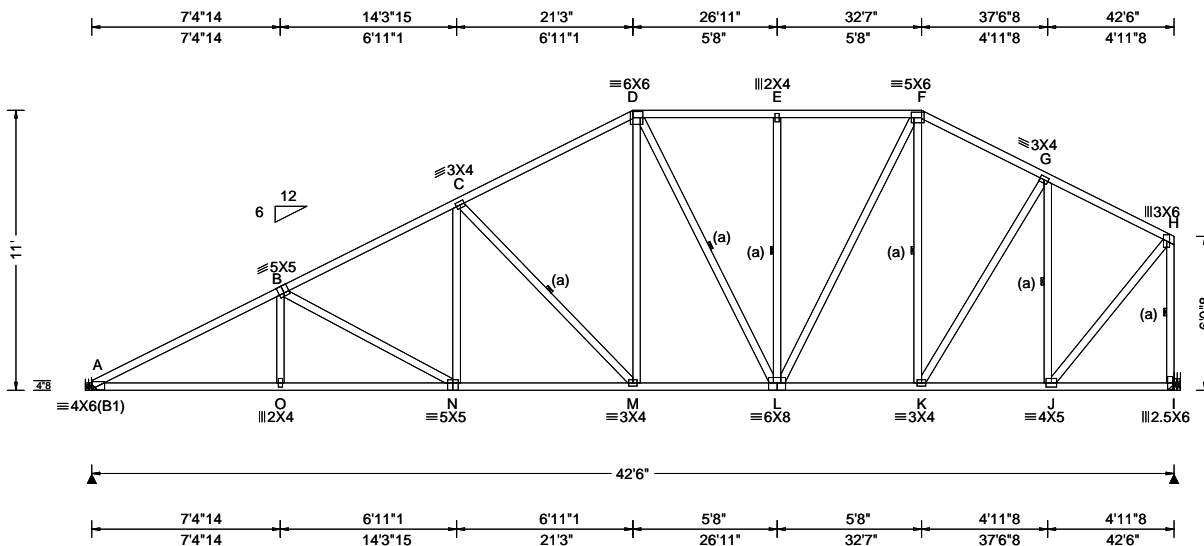

Loading Criteria (psf) TCLL: 20.00 TCDL: 10.00 BCLL: 0.00 BCDL: 10.00 Des Ld: 40.00 NCBCLL: 10.00 Soffit: 2.00 Load Duration: 1.25 Spacing: 24.0 "	Wind Criteria Wind Std: ASCE 7-10 Speed: 130 mph Enclosure: Closed Risk Category: II EXP: C Kzt: NA Mean Height: 15.00 ft TCDL: 5.0 psf BCDL: 5.0 psf MWFRS Parallel Dist: h/2 to h C&C Dist a: 4.25 ft Loc. from endwall: not in 13.00 ft GCpi: 0.18 Wind Duration: 1.60	Snow Criteria (Pg,Pf in PSF) Pg: NA Ct: NA CAT: NA Pf: NA Ce: NA Lu: NA Cs: NA Snow Duration: NA Building Code: FBC 2017 RES TPI Std: 2014 Rep Fac: Yes FT/RT:20(0)/10(0) Plate Type(s): WAVE	Def/CSI Criteria PP Deflection in loc L/defl L/# VERT(LL): 0.164 N 999 240 VERT(CL): 0.338 N 999 180 HORZ(LL): 0.061 J - - HORZ(TL): 0.126 J - - Creep Factor: 2.0 Max TC CSI: 0.808 Max BC CSI: 0.849 Max Web CSI: 0.719 VIEW Ver: 19.02.02B.0122.15	▲ Maximum Reactions (lbs) Gravity Loc R+ / R- / Rh / Rw / U / RL Non-Gravity A 1755 - / - / 1092 / 294 / 243 I 1745 - / - / 920 / 319 - / - Wind reactions based on MWFRS A Brg Width = - Min Req = - I Brg Width = - Min Req = - Members not listed have forces less than 375# Maximum Top Chord Forces Per Ply (lbs) Chords Tens.Comp. Chords Tens. Comp. A - B 765 - 3298 E - F 578 - 1626 B - C 696 - 2700 F - G 506 - 1475 C - D 627 - 2059 G - H 332 - 1101 D - E 578 - 1626
--	---	--	--	---

Lumber
Top chord: 2x4 SP #2;
Bot chord: 2x4 SP #2;
Webs: 2x4 SP #3;

Bracing
(a) Continuous lateral restraint equally spaced on member.

Hangers / Ties
(J) Hanger Support Required, by others

Wind
Wind loads based on MWFRS with additional C&C member design.
Right end vertical not exposed to wind pressure.
Uplifts based on an elevation at or above 1000 ft.

Additional Notes
The overall height of this truss excluding overhang is 11'-0".

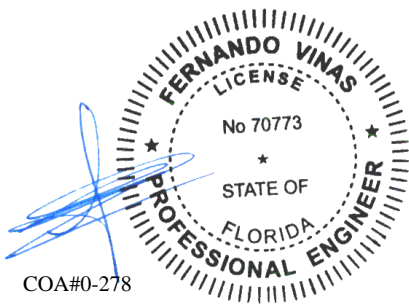

02/28/2022

****WARNING** READ AND FOLLOW ALL NOTES ON THIS DRAWING!**
****IMPORTANT** FURNISH THIS DRAWING TO ALL CONTRACTORS INCLUDING THE INSTALLERS**
Trusses require extreme care in fabricating, handling, shipping, installing and bracing. Refer to and follow the latest edition of BCSI (Building Component Safety Information, by TPI and SBCA) for safety practices prior to performing these functions. Installers shall provide temporary bracing per BCSI. Unless noted otherwise, top chord shall have properly attached structural sheathing and bottom chord shall have a properly attached rigid ceiling. Locations shown for permanent lateral restraint of webs shall have bracing installed per BCSI sections B3, B7, or B10, as applicable. Apply plates to each face of truss and position as shown above and on the Joint Details, unless noted otherwise. Refer to drawings 160A-Z for standard plate positions. Refer to job's General Notes page for additional information.
Alpine, a division of ITW Building Components Group Inc. shall not be responsible for any deviation from this drawing, any failure to build the truss in conformance with ANSI/TPI 1, or for handling, shipping, installation and bracing of trusses. A seal on this drawing or cover page listing this drawing, indicates acceptance of professional engineering responsibility solely for the design shown. The suitability and use of this drawing for any structure is the responsibility of the Building Designer per ANSI/TPI 1 Sec.2.
For more information see these web sites: Alpine: www.alpineitw.com; TPI: www.tpinst.org; SBCA: www.sbcindustry.com; ICC: www.iccsafe.org



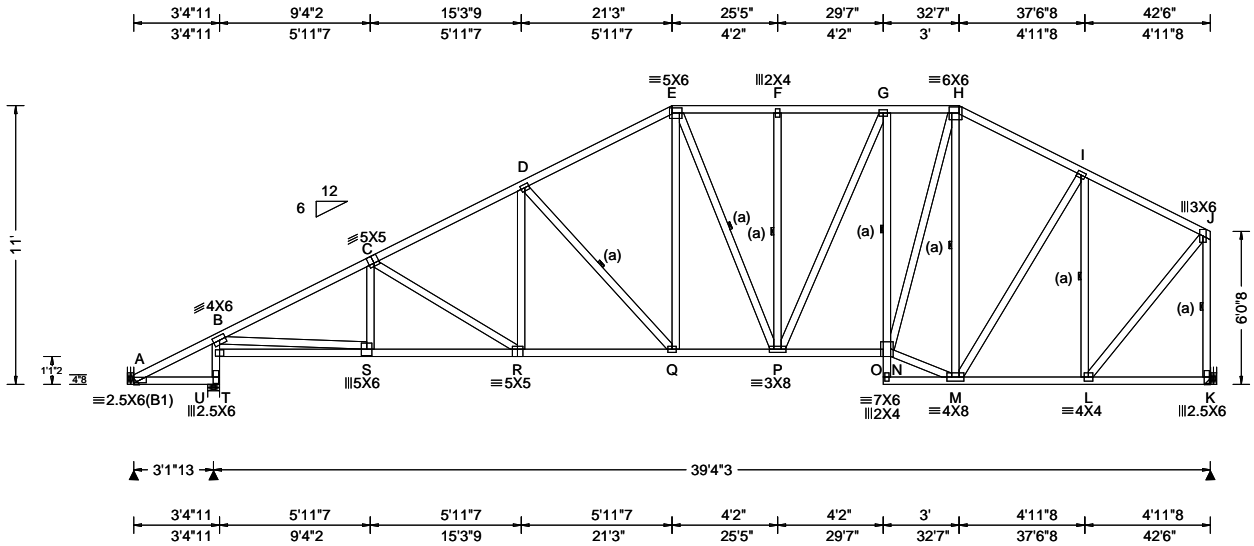

Loading Criteria (psf) TCCL: 20.00 TCDL: 10.00 BCLL: 0.00 BCDL: 10.00 Des Ld: 40.00 NCBCLL: 10.00 Soffit: 2.00 Load Duration: 1.25 Spacing: 24.0 "	Wind Criteria Wind Std: ASCE 7-10 Speed: 130 mph Enclosure: Closed Risk Category: II EXP: C Kzt: NA Mean Height: 15.00 ft TCDL: 5.0 psf BCDL: 5.0 psf MWFRS Parallel Dist: h to 2h C&C Dist a: 4.25 ft Loc. from endwall: not in 13.00 ft GCp: 0.18 Wind Duration: 1.60	Snow Criteria (Pg,Pf in PSF) Pg: NA Ct: NA CAT: NA Pf: NA Ce: NA Lu: NA Cs: NA Snow Duration: NA Building Code: FBC 2017 RES TPI Std: 2014 Rep Fac: Yes FT/RT:20(0)/10(0) Plate Type(s): WAVE	Defl/CSI Criteria PP Deflection in loc L/def L/# VERT(LL): 0.123 Q 999 240 VERT(CL): 0.253 Q 999 180 HORZ(LL): 0.053 L - - HORZ(TL): 0.108 L - - Creep Factor: 2.0 Max TC CSI: 0.525 Max BC CSI: 0.593 Max Web CSI: 0.833 VIEW Ver: 21.01.01A.0521.20	▲ Maximum Reactions (lbs) <table style="width:100%; border-collapse: collapse;"> <thead> <tr> <th rowspan="2">Loc</th> <th colspan="3">Gravity</th> <th colspan="3">Non-Gravity</th> </tr> <tr> <th>R+</th> <th>/R-</th> <th>/Rh</th> <th>/Rw</th> <th>/U</th> <th>/RL</th> </tr> </thead> <tbody> <tr> <td>A</td> <td>94</td> <td>-19</td> <td>-</td> <td>148</td> <td>76</td> <td>243</td> </tr> <tr> <td>U</td> <td>1845</td> <td>-</td> <td>-</td> <td>1230</td> <td>210</td> <td>-</td> </tr> <tr> <td>K</td> <td>1610</td> <td>-</td> <td>-</td> <td>871</td> <td>74</td> <td>-</td> </tr> </tbody> </table> <p>Wind reactions based on MWFRS A Brg Wid = - Min Req = - U Brg Wid = 5.7 K Brg Wid = - Bearing U is a rigid surface. Members not listed have forces less than 375# Maximum Top Chord Forces Per Ply (lbs)</p> <table style="width:100%; border-collapse: collapse;"> <thead> <tr> <th>Chords</th> <th>Tens.Comp.</th> <th>Chords</th> <th>Tens. Comp.</th> </tr> </thead> <tbody> <tr> <td>B - C</td> <td>591 -2621</td> <td>F - G</td> <td>569 -1621</td> </tr> <tr> <td>C - D</td> <td>626 -2373</td> <td>G - H</td> <td>530 -1468</td> </tr> <tr> <td>D - E</td> <td>595 -1924</td> <td>H - I</td> <td>468 -1341</td> </tr> <tr> <td>E - F</td> <td>569 -1622</td> <td>I - J</td> <td>307 -1012</td> </tr> </tbody> </table> <p>Maximum Bot Chord Forces Per Ply (lbs)</p> <table style="width:100%; border-collapse: collapse;"> <thead> <tr> <th>Chords</th> <th>Tens.Comp.</th> <th>Chords</th> <th>Tens. Comp.</th> </tr> </thead> <tbody> <tr> <td>S - R</td> <td>2274 -594</td> <td>P - N</td> <td>1480 -354</td> </tr> <tr> <td>R - Q</td> <td>2041 -533</td> <td>M - L</td> <td>881 -224</td> </tr> <tr> <td>Q - P</td> <td>1642 -402</td> <td></td> <td></td> </tr> </tbody> </table> <p>Maximum Web Forces Per Ply (lbs)</p> <table style="width:100%; border-collapse: collapse;"> <thead> <tr> <th>Webs</th> <th>Tens.Comp.</th> <th>Webs</th> <th>Tens. Comp.</th> </tr> </thead> <tbody> <tr> <td>T - U</td> <td>523 -1816</td> <td>N - H</td> <td>1203 -324</td> </tr> <tr> <td>T - B</td> <td>531 -1764</td> <td>M - H</td> <td>188 -820</td> </tr> <tr> <td>B - S</td> <td>2186 -558</td> <td>M - I</td> <td>477 -82</td> </tr> <tr> <td>D - Q</td> <td>199 -603</td> <td>I - L</td> <td>279 -910</td> </tr> <tr> <td>E - Q</td> <td>557 -132</td> <td>L - J</td> <td>1331 -337</td> </tr> <tr> <td>G - N</td> <td>191 -539</td> <td>J - K</td> <td>455 -1571</td> </tr> <tr> <td>N - M</td> <td>1209 -276</td> <td></td> <td></td> </tr> </tbody> </table>	Loc	Gravity			Non-Gravity			R+	/R-	/Rh	/Rw	/U	/RL	A	94	-19	-	148	76	243	U	1845	-	-	1230	210	-	K	1610	-	-	871	74	-	Chords	Tens.Comp.	Chords	Tens. Comp.	B - C	591 -2621	F - G	569 -1621	C - D	626 -2373	G - H	530 -1468	D - E	595 -1924	H - I	468 -1341	E - F	569 -1622	I - J	307 -1012	Chords	Tens.Comp.	Chords	Tens. Comp.	S - R	2274 -594	P - N	1480 -354	R - Q	2041 -533	M - L	881 -224	Q - P	1642 -402			Webs	Tens.Comp.	Webs	Tens. Comp.	T - U	523 -1816	N - H	1203 -324	T - B	531 -1764	M - H	188 -820	B - S	2186 -558	M - I	477 -82	D - Q	199 -603	I - L	279 -910	E - Q	557 -132	L - J	1331 -337	G - N	191 -539	J - K	455 -1571	N - M	1209 -276		
Loc	Gravity			Non-Gravity																																																																																																						
	R+	/R-	/Rh	/Rw	/U	/RL																																																																																																				
A	94	-19	-	148	76	243																																																																																																				
U	1845	-	-	1230	210	-																																																																																																				
K	1610	-	-	871	74	-																																																																																																				
Chords	Tens.Comp.	Chords	Tens. Comp.																																																																																																							
B - C	591 -2621	F - G	569 -1621																																																																																																							
C - D	626 -2373	G - H	530 -1468																																																																																																							
D - E	595 -1924	H - I	468 -1341																																																																																																							
E - F	569 -1622	I - J	307 -1012																																																																																																							
Chords	Tens.Comp.	Chords	Tens. Comp.																																																																																																							
S - R	2274 -594	P - N	1480 -354																																																																																																							
R - Q	2041 -533	M - L	881 -224																																																																																																							
Q - P	1642 -402																																																																																																									
Webs	Tens.Comp.	Webs	Tens. Comp.																																																																																																							
T - U	523 -1816	N - H	1203 -324																																																																																																							
T - B	531 -1764	M - H	188 -820																																																																																																							
B - S	2186 -558	M - I	477 -82																																																																																																							
D - Q	199 -603	I - L	279 -910																																																																																																							
E - Q	557 -132	L - J	1331 -337																																																																																																							
G - N	191 -539	J - K	455 -1571																																																																																																							
N - M	1209 -276																																																																																																									

Lumber

Top chord: 2x4 SP #2;
 Bot chord: 2x4 SP #2;
 Webs: 2x4 SP #3;

Bracing

(a) Continuous lateral restraint equally spaced on member.

Plating Notes

All plates are 3X4 except as noted.

Hangers / Ties

(J) Hanger Support Required, by others

Wind

Wind loads based on MWFRS with additional C&C member design.
 Right end vertical not exposed to wind pressure.
 Uplifts based on an elevation at or above 1000 ft.

Additional Notes

The overall height of this truss excluding overhang is 11'-0".

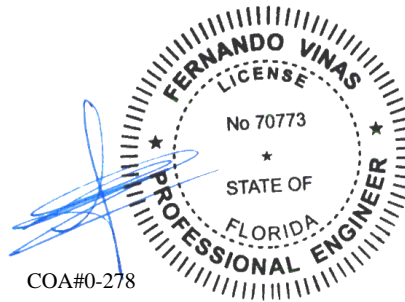

****WARNING** READ AND FOLLOW ALL NOTES ON THIS DRAWING!**
****IMPORTANT** FURNISH THIS DRAWING TO ALL CONTRACTORS INCLUDING THE INSTALLERS**
 Trusses require extreme care in fabricating, handling, shipping, installing and bracing. Refer to and follow the latest edition of BCSI (Building Component Safety Information, by TPI and SBCA) for safety practices prior to performing these functions. Installers shall provide temporary bracing per BCSI. Unless noted otherwise, top chord shall have properly attached structural sheathing and bottom chord shall have a properly attached rigid ceiling. Locations shown for permanent lateral restraint of webs shall have bracing installed per BCSI sections B3, B7, or B10, as applicable. Apply plates to each face of truss and position as shown above and on the Joint Details, unless noted otherwise. Refer to drawings 160A-Z for standard plate positions. Refer to job's General Notes page for additional information.
 Alpine, a division of ITW Building Components Group Inc. shall not be responsible for any deviation from this drawing, any failure to build the truss in conformance with ANSI/TPI 1, or for handling, shipping, installation and bracing of trusses. A seal on this drawing or cover page listing this drawing, indicates acceptance of professional engineering responsibility solely for the design shown. The suitability and use of this drawing for any structure is the responsibility of the Building Designer per ANSI/TPI 1 Sec.2.
 For more information see these web sites: Alpine: alpineitw.com; TPI: tpinst.org; SBCA: sbccomponents.com; ICC: iccsafe.org; AWC: awc.org



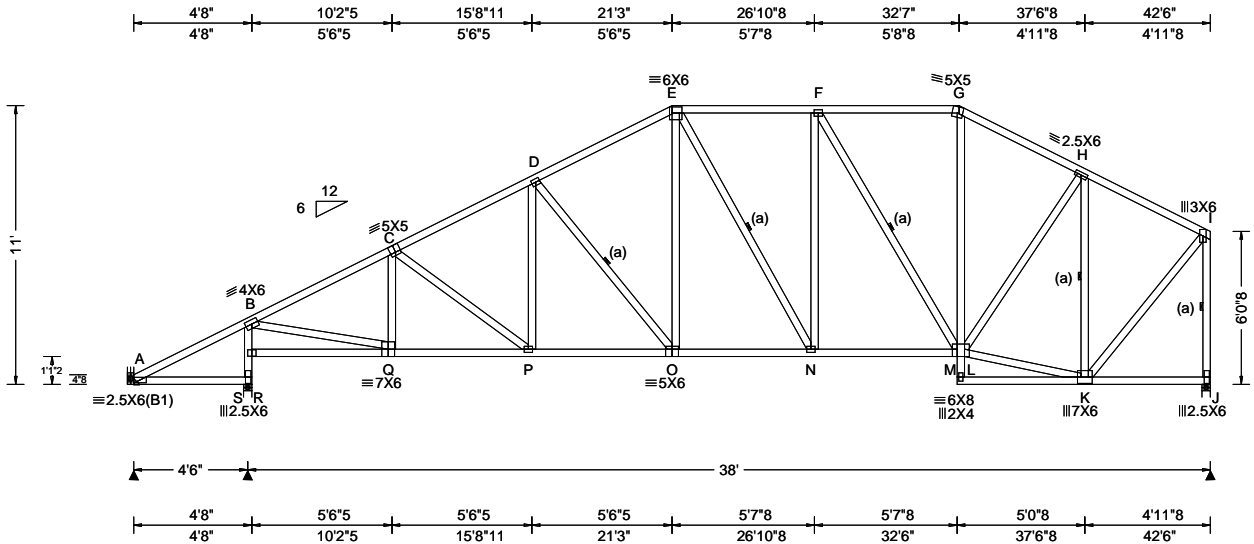

Loading Criteria (psf) TCLL: 20.00 TCDL: 10.00 BCLL: 0.00 BCDL: 10.00 Des Ld: 40.00 NCBCLL: 10.00 Soffit: 2.00 Load Duration: 1.25 Spacing: 24.0 "	Wind Criteria Wind Std: ASCE 7-10 Speed: 130 mph Enclosure: Closed Risk Category: II EXP: C Kzt: NA Mean Height: 15.00 ft TCDL: 5.0 psf BCDL: 5.0 psf MWFRS Parallel Dist: h to 2h C&C Dist a: 4.25 ft Loc. from endwall: not in 13.00 ft GCp: 0.18 Wind Duration: 1.60	Snow Criteria (Pg,Pf in PSF) Pg: NA Ct: NA CAT: NA Pf: NA Ce: NA Lu: NA Cs: NA Snow Duration: NA Building Code: FBC 2017 RES TPI Std: 2014 Rep Fac: Yes FT/RT:20(0)/10(0) Plate Type(s): WAVE	Defl/CSI Criteria PP Deflection in loc L/def L/# VERT(LL): 0.118 O 999 240 VERT(CL): 0.222 O 999 180 HORZ(LL): 0.049 K - - HORZ(TL): 0.092 K - - Creep Factor: 2.0 Max TC CSI: 0.497 Max BC CSI: 0.685 Max Web CSI: 0.827 VIEW Ver: 21.01.01A.0521.20	▲ Maximum Reactions (lbs) Gravity Loc R+ / R- / Rh / Rw / U / RL Non-Gravity A 136 - / - / 154 / 55 / 243 S 2029 - / - / 1226 / 206 - / - J 1727 - / - / 850 / 68 - / - Wind reactions based on MWFRS A Brg Wid = - Min Req = - S Brg Wid = 4.0 Min Req = 2.4 J Brg Wid = 4.0 Bearings S & J are a rigid surface. Members not listed have forces less than 375# Maximum Top Chord Forces Per Ply (lbs) Chords Tens.Comp. Chords Tens. Comp.
--	---	---	--	---

Lumber

Top chord: 2x4 SP #2;
Bot chord: 2x4 SP #2;
Webs: 2x4 SP #3;

Bracing

(a) Continuous lateral restraint equally spaced on member.

Plating Notes

All plates are 3X4 except as noted.

Hangers / Ties

(J) Hanger Support Required, by others

Loading

Truss passed check for 20 psf additional bottom chord live load in areas with 42"-high x 24"-wide clearance.

Wind

Wind loads based on MWFRS with additional C&C member design.

Right end vertical not exposed to wind pressure.
Uplifts based on an elevation at or above 1000 ft.

Additional Notes

The overall height of this truss excluding overhang is 11'-0".

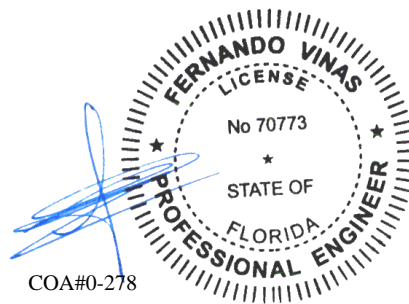

02/28/2022

****WARNING** READ AND FOLLOW ALL NOTES ON THIS DRAWING!**
****IMPORTANT** FURNISH THIS DRAWING TO ALL CONTRACTORS INCLUDING THE INSTALLERS**
Trusses require extreme care in fabricating, handling, shipping, installing and bracing. Refer to and follow the latest edition of BCSI (Building Component Safety Information, by TPI and SBCA) for safety practices prior to performing these functions. Installers shall provide temporary bracing per BCSI. Unless noted otherwise, top chord shall have properly attached structural sheathing and bottom chord shall have a properly attached rigid ceiling. Locations shown for permanent lateral restraint of webs shall have bracing installed per BCSI sections B3, B7, or B10, as applicable. Apply plates to each face of truss and position as shown above and on the Joint Details, unless noted otherwise. Refer to drawings 160A-Z for standard plate positions. Refer to job's General Notes page for additional information.
Alpine, a division of ITW Building Components Group Inc. shall not be responsible for any deviation from this drawing, any failure to build the truss in conformance with ANSI/TPI 1, or for handling, shipping, installation and bracing of trusses. A seal on this drawing or cover page listing this drawing, indicates acceptance of professional engineering responsibility solely for the design shown. The suitability and use of this drawing for any structure is the responsibility of the Building Designer per ANSI/TPI 1 Sec.2.
For more information see these web sites: Alpine: alpineitw.com; TPI: tpinst.org; SBCA: sbccomponents.com; ICC: iccsafe.org; AWC: awc.org



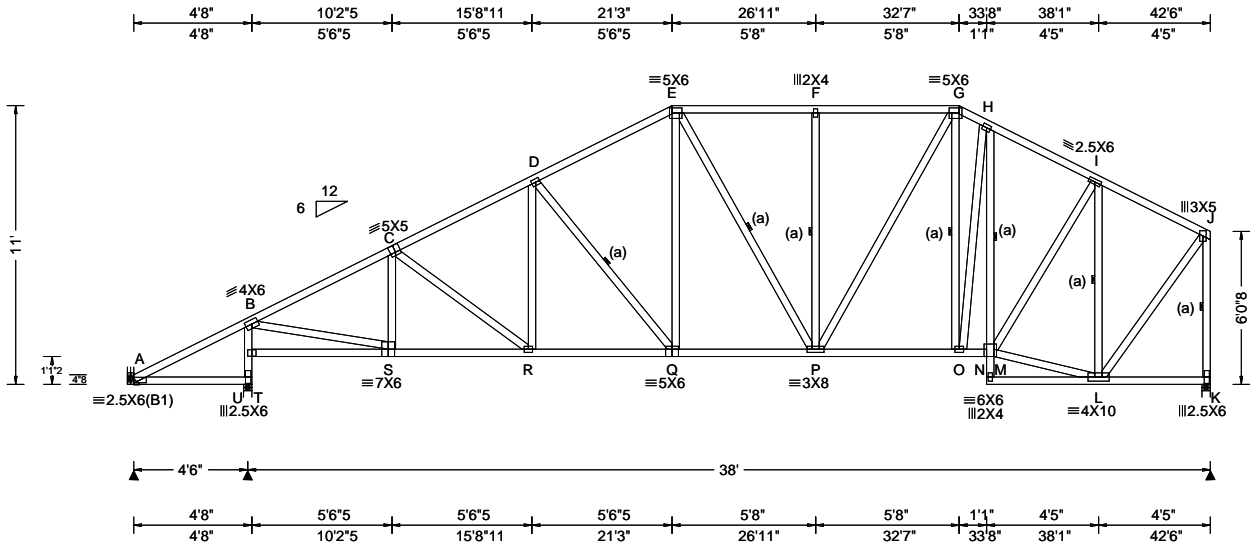

Loading Criteria (psf) TCLL: 20.00 TCDL: 10.00 BCLL: 0.00 BCDL: 10.00 Des Ld: 40.00 NCBCLL: 10.00 Soffit: 2.00 Load Duration: 1.25 Spacing: 24.0 "	Wind Criteria Wind Std: ASCE 7-10 Speed: 130 mph Enclosure: Closed Risk Category: II EXP: C Kzt: NA Mean Height: 15.00 ft TCDL: 5.0 psf BCDL: 5.0 psf MWFRS Parallel Dist: h to 2h C&C Dist a: 4.25 ft Loc. from endwall: not in 13.00 ft GCp: 0.18 Wind Duration: 1.60	Snow Criteria (Pg,Pf in PSF) Pg: NA Ct: NA CAT: NA Pf: NA Ce: NA Lu: NA Cs: NA Snow Duration: NA Building Code: FBC 2017 RES TPI Std: 2014 Rep Fac: Yes FT/RT:20(0)/10(0) Plate Type(s): WAVE	Defl/CSI Criteria PP Deflection in loc L/defl L/# VERT(LL): 0.093 Q 999 240 VERT(CL): 0.191 Q 999 180 HORZ(LL): 0.038 L - - HORZ(TL): 0.079 L - - Creep Factor: 2.0 Max TC CSI: 0.484 Max BC CSI: 0.489 Max Web CSI: 0.732 VIEW Ver: 21.01.01A.0521.20	▲ Maximum Reactions (lbs) Gravity Loc R+ / R- / Rh / Rw / U / RL Non-Gravity A 144 /- /- /155 /55 /243 U 1847 /- /- /1225 /206 /- K 1554 /- /- /850 /68 /- Wind reactions based on MWFRS A Brg Wid = - Min Req = - U Brg Wid = 4.0 Min Req = 2.2 K Brg Wid = 4.0 Bearings U & K are a rigid surface. Members not listed have forces less than 375# Maximum Top Chord Forces Per Ply (lbs) Chords Tens.Comp. Chords Tens. Comp. B - C 472 -2097 F - G 539 -1503 C - D 561 -2086 G - H 493 -1342 D - E 561 -1779 H - I 470 -1387 E - F 539 -1503 I - J 282 -925
--	---	---	---	---

Lumber

Top chord: 2x4 SP #2;
Bot chord: 2x4 SP #2;
Webs: 2x4 SP #3;

Bracing

(a) Continuous lateral restraint equally spaced on member.

Plating Notes

All plates are 3X4 except as noted.

Hangers / Ties

(J) Hanger Support Required, by others

Wind

Wind loads based on MWFRS with additional C&C member design.

Right end vertical not exposed to wind pressure.

Uplifts based on an elevation at or above 1000 ft.

Additional Notes

The overall height of this truss excluding overhang is 11'-0".

Maximum Bot Chord Forces Per Ply (lbs)

Chords	Tens.Comp.	Chords	Tens. Comp.
S - R	1822 -474	P - O	1197 -275
R - Q	1793 -467	O - M	1191 -282
Q - P	1521 -369		

Maximum Web Forces Per Ply (lbs)

Webs	Tens.Comp.	Webs	Tens. Comp.
T - U	501 -1798	M - I	730 -152
T - B	508 -1745	M - L	808 -208
B - S	1922 -485	I - L	337 -1137
D - Q	158 -438	L - J	1283 -329
E - Q	483 -106	J - K	440 -1519
P - G	603 -167		

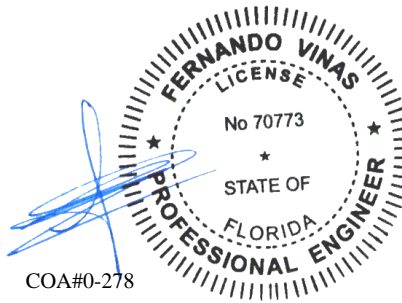

02/28/2022

****WARNING** READ AND FOLLOW ALL NOTES ON THIS DRAWING!**
****IMPORTANT** FURNISH THIS DRAWING TO ALL CONTRACTORS INCLUDING THE INSTALLERS**
Trusses require extreme care in fabricating, handling, shipping, installing and bracing. Refer to and follow the latest edition of BCSI (Building Component Safety Information, by TPI and SBCA) for safety practices prior to performing these functions. Installers shall provide temporary bracing per BCSI. Unless noted otherwise, top chord shall have properly attached structural sheathing and bottom chord shall have a properly attached rigid ceiling. Locations shown for permanent lateral restraint of webs shall have bracing installed per BCSI sections B3, B7, or B10, as applicable. Apply plates to each face of truss and position as shown above and on the Joint Details, unless noted otherwise. Refer to drawings 160A-Z for standard plate positions. Refer to job's General Notes page for additional information.
Alpine, a division of ITW Building Components Group Inc. shall not be responsible for any deviation from this drawing, any failure to build the truss in conformance with ANSI/TPI 1, or for handling, shipping, installation and bracing of trusses. A seal on this drawing or cover page listing this drawing, indicates acceptance of professional engineering responsibility solely for the design shown. The suitability and use of this drawing for any structure is the responsibility of the Building Designer per ANSI/TPI 1 Sec.2.
For more information see these web sites: Alpine: alpineitw.com; TPI: tpinst.org; SBCA: sbccomponents.com; ICC: iccsafe.org; AWC: awc.org



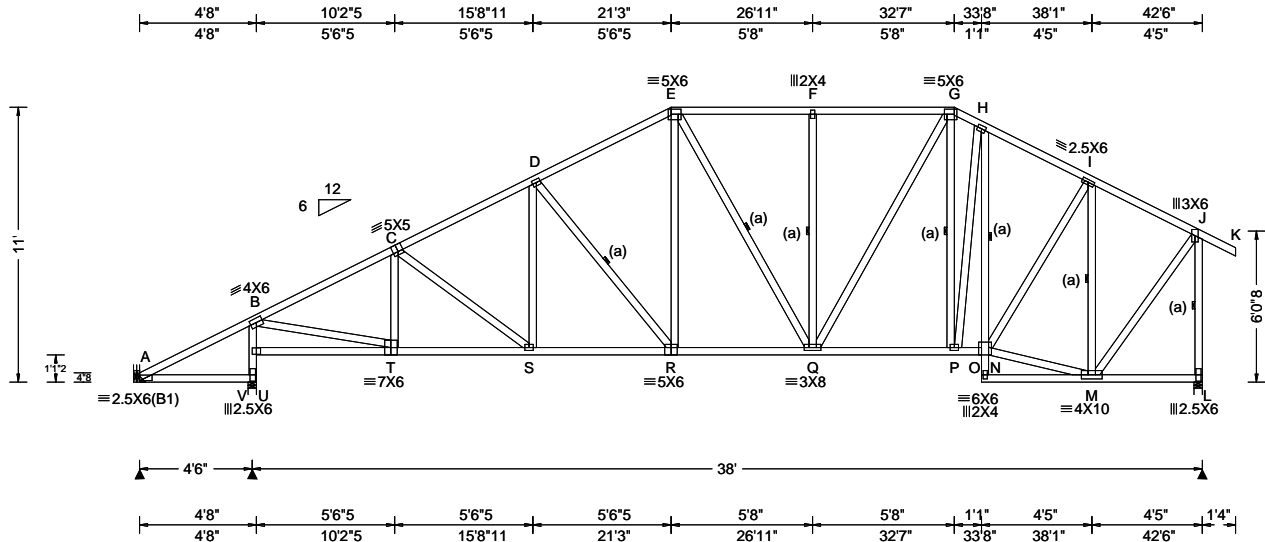

Loading Criteria (psf) TCLL: 20.00 TCDL: 10.00 BCLL: 0.00 BCDL: 10.00 Des Ld: 40.00 NCBCLL: 10.00 Soffit: 2.00 Load Duration: 1.25 Spacing: 24.0 "	Wind Criteria Wind Std: ASCE 7-10 Speed: 130 mph Enclosure: Closed Risk Category: II EXP: C Kzt: NA Mean Height: 15.00 ft TCDL: 5.0 psf BCDL: 5.0 psf MWFRS Parallel Dist: h to 2h C&C Dist a: 4.25 ft Loc. from endwall: not in 13.00 ft GCpi: 0.18 Wind Duration: 1.60	Snow Criteria (Pg,Pf in PSF) Pg: NA Ct: NA CAT: NA Pf: NA Ce: NA Lu: NA Cs: NA Snow Duration: NA Building Code: FBC 2017 RES TPI Std: 2014 Rep Fac: Yes FT/RT:20(0)/10(0) Plate Type(s): WAVE	Defl/CSI Criteria PP Deflection in loc L/defl L/# VERT(LL): 0.093 R 999 240 VERT(CL): 0.191 R 999 180 HORZ(LL): 0.038 M - - HORZ(TL): 0.078 M - - Creep Factor: 2.0 Max TC CSI: 0.484 Max BC CSI: 0.489 Max Web CSI: 0.731 VIEW Ver: 21.01.01A.0521.20	▲ Maximum Reactions (lbs) Gravity Loc R+ / R- / Rh / Rw / U / RL Non-Gravity A 144 - / - / /166 /61 /265 V 1845 - / - / /1230 /196 - L 1645 - / - / /924 /96 - Wind reactions based on MWFRS A Brg Wid = - Min Req = - V Brg Wid = 4.0 Min Req = 2.2 L Brg Wid = 4.0 Bearings V & L are a rigid surface. Members not listed have forces less than 375# Maximum Top Chord Forces Per Ply (lbs) Chords Tens.Comp. Chords Tens. Comp. B - C 486 -2094 F - G 544 -1500 C - D 569 -2083 G - H 501 -1339 D - E 567 -1776 H - I 472 -1380 E - F 544 -1500 I - J 311 -923 Maximum Bot Chord Forces Per Ply (lbs) Chords Tens.Comp. Chords Tens. Comp. T - S 1820 -442 Q - P 1192 -256 S - R 1791 -430 P - N 1186 -269 R - Q 1518 -329 Maximum Web Forces Per Ply (lbs) Webs Tens.Comp. Webs Tens. Comp. U - V 493 -1797 N - I 738 -145 U - B 500 -1743 N - M 799 -192 B - T 1920 -457 I - M 312 -1124 D - R 162 -439 M - J 1269 -303 E - R 483 -109 J - L 515 -1610 Q - G 605 -167
--	--	---	---	---

Lumber

Top chord: 2x4 SP #2;
Bot chord: 2x4 SP #2;
Webs: 2x4 SP #3;

Bracing

(a) Continuous lateral restraint equally spaced on member.

Plating Notes

All plates are 3X4 except as noted.

Hangers / Ties

(J) Hanger Support Required, by others

Wind

Wind loads based on MWFRS with additional C&C member design.

Right end vertical not exposed to wind pressure.

Uplifts based on an elevation at or above 1000 ft.

Additional Notes

The overall height of this truss excluding overhang is 11'-0".

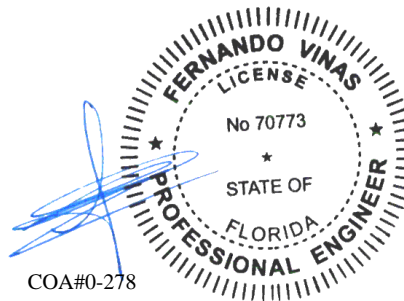

COA#0-278

02/28/2022

****WARNING** READ AND FOLLOW ALL NOTES ON THIS DRAWING!**
****IMPORTANT** FURNISH THIS DRAWING TO ALL CONTRACTORS INCLUDING THE INSTALLERS**
Trusses require extreme care in fabricating, handling, shipping, installing and bracing. Refer to and follow the latest edition of BCSI (Building Component Safety Information, by TPI and SBCA) for safety practices prior to performing these functions. Installers shall provide temporary bracing per BCSI. Unless noted otherwise, top chord shall have properly attached structural sheathing and bottom chord shall have a properly attached rigid ceiling. Locations shown for permanent lateral restraint of webs shall have bracing installed per BCSI sections B3, B7, or B10, as applicable. Apply plates to each face of truss and position as shown above and on the Joint Details, unless noted otherwise. Refer to drawings 160A-Z for standard plate positions. Refer to job's General Notes page for additional information.
Alpine, a division of ITW Building Components Group Inc. shall not be responsible for any deviation from this drawing, any failure to build the truss in conformance with ANSI/TPI 1, or for handling, shipping, installation and bracing of trusses. A seal on this drawing or cover page listing this drawing, indicates acceptance of professional engineering responsibility solely for the design shown. The suitability and use of this drawing for any structure is the responsibility of the Building Designer per ANSI/TPI 1 Sec.2.
For more information see these web sites: Alpine: alpineitw.com; TPI: tpinst.org; SBCA: sbccomponents.com; ICC: iccsafe.org; AWC: awc.org



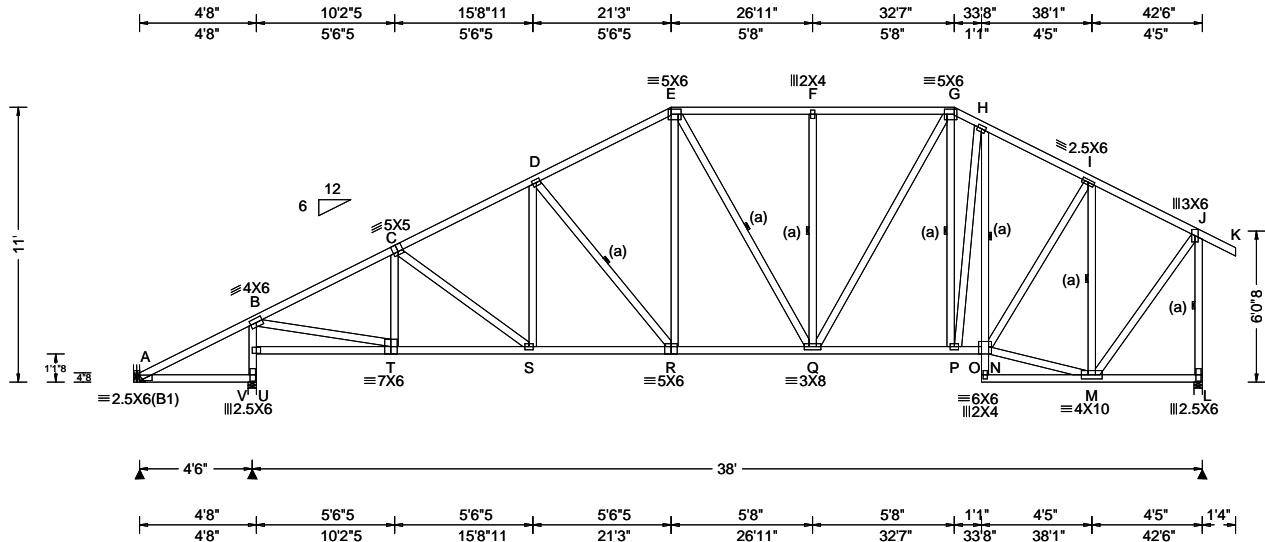

Loading Criteria (psf) TCLL: 20.00 TCDL: 10.00 BCLL: 0.00 BCDL: 10.00 Des Ld: 40.00 NCBCLL: 10.00 Soffit: 2.00 Load Duration: 1.25 Spacing: 24.0 "	Wind Criteria Wind Std: ASCE 7-10 Speed: 130 mph Enclosure: Closed Risk Category: II EXP: C Kzt: NA Mean Height: 15.00 ft TCDL: 5.0 psf BCDL: 5.0 psf MWFRS Parallel Dist: h to 2h C&C Dist a: 4.25 ft Loc. from endwall: not in 13.00 ft GCpi: 0.18 Wind Duration: 1.60	Snow Criteria (Pg,Pf in PSF) Pg: NA Ct: NA CAT: NA Pf: NA Ce: NA Lu: NA Cs: NA Snow Duration: NA Building Code: FBC 2017 RES TPI Std: 2014 Rep Fac: Yes FT/RT:20(0)/10(0) Plate Type(s): WAVE	Defl/CSI Criteria PP Deflection in loc L/defl L/# VERT(LL): 0.094 R 999 240 VERT(CL): 0.193 R 999 180 HORZ(LL): 0.039 M - - HORZ(TL): 0.080 M - - Creep Factor: 2.0 Max TC CSI: 0.484 Max BC CSI: 0.491 Max Web CSI: 0.735 VIEW Ver: 21.01.01A.0521.20	▲ Maximum Reactions (lbs) Gravity Non-Gravity Loc R+ / R- / Rh / Rw / U / RL A 145 - / - / /167 /61 /265 V 1843 - / - / /1230 /196 - L 1645 - / - / /924 /96 - Wind reactions based on MWFRS A Brg Wid = - Min Req = - V Brg Wid = 4.0 Min Req = 2.2 L Brg Wid = 4.0 Bearings V & L are a rigid surface. Members not listed have forces less than 375# Maximum Top Chord Forces Per Ply (lbs) Chords Tens.Comp. Chords Tens. Comp. B - C 490 -2112 F - G 545 -1505 C - D 571 -2093 G - H 502 -1344 D - E 568 -1782 H - I 473 -1385 E - F 545 -1505 I - J 311 -923
--	--	---	---	--

Lumber

Top chord: 2x4 SP #2;
Bot chord: 2x4 SP #2;
Webs: 2x4 SP #3;

Bracing

(a) Continuous lateral restraint equally spaced on member.

Plating Notes

All plates are 3X4 except as noted.

Hangers / Ties

(J) Hanger Support Required, by others

Wind

Wind loads based on MWFRS with additional C&C member design.

Right end vertical not exposed to wind pressure.

Uplifts based on an elevation at or above 1000 ft.

Additional Notes

The overall height of this truss excluding overhang is 11-0-0.

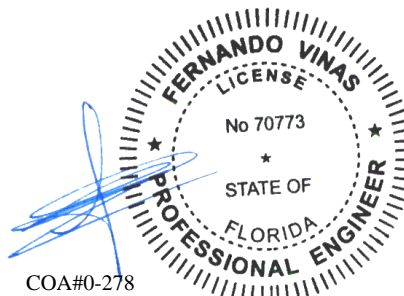

COA#0-278

02/28/2022

****WARNING** READ AND FOLLOW ALL NOTES ON THIS DRAWING!**
****IMPORTANT** FURNISH THIS DRAWING TO ALL CONTRACTORS INCLUDING THE INSTALLERS**
Trusses require extreme care in fabricating, handling, shipping, installing and bracing. Refer to and follow the latest edition of BCSI (Building Component Safety Information, by TPI and SBCA) for safety practices prior to performing these functions. Installers shall provide temporary bracing per BCSI. Unless noted otherwise, top chord shall have properly attached structural sheathing and bottom chord shall have a properly attached rigid ceiling. Locations shown for permanent lateral restraint of webs shall have bracing installed per BCSI sections B3, B7, or B10, as applicable. Apply plates to each face of truss and position as shown above and on the Joint Details, unless noted otherwise. Refer to drawings 160A-Z for standard plate positions. Refer to job's General Notes page for additional information.
Alpine, a division of ITW Building Components Group Inc. shall not be responsible for any deviation from this drawing, any failure to build the truss in conformance with ANSI/TPI 1, or for handling, shipping, installation and bracing of trusses. A seal on this drawing or cover page listing this drawing, indicates acceptance of professional engineering responsibility solely for the design shown. The suitability and use of this drawing for any structure is the responsibility of the Building Designer per ANSI/TPI 1 Sec.2.
For more information see these web sites: Alpine: alpineitw.com; TPI: tpinst.org; SBCA: sbccomponents.com; ICC: iccsafe.org; AWC: awc.org



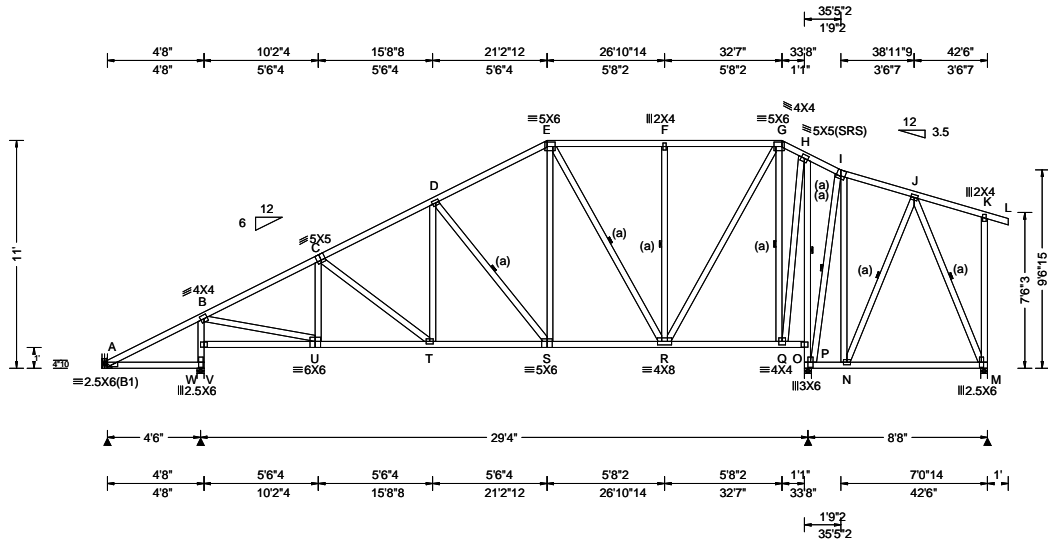

Loading Criteria (psf) TCLL: 20.00 TCDL: 10.00 BCLL: 0.00 BCDL: 10.00 Des Ld: 40.00 NCBCLL: 10.00 Soffit: 2.00 Load Duration: 1.25 Spacing: 24.0 "	Wind Criteria Wind Std: ASCE 7-10 Speed: 130 mph Enclosure: Closed Risk Category: II EXP: C Kzt: NA Mean Height: 15.00 ft TCDL: 5.0 psf BCDL: 5.0 psf MWFRS Parallel Dist: h to 2h C&C Dist a: 4.25 ft Loc. from endwall: not in 13.00 ft GCp: 0.18 Wind Duration: 1.60	Snow Criteria (Pg, Pf in PSF) Pg: NA Ct: NA CAT: NA Pf: NA Ce: NA Lu: NA Cs: NA Snow Duration: NA Building Code: FBC 2017 RES TPI Std: 2014 Rep Fac: Yes FT/RT: 20(0)/10(0) Plate Type(s): WAVE	Defl/CSI Criteria PP Deflection in loc L/def L/# VERT(LL): 0.061 T 999 240 VERT(CL): 0.124 T 999 180 HORZ(LL): 0.019 M - - HORZ(TL): 0.039 M - - Creep Factor: 2.0 Max TC CSI: 0.455 Max BC CSI: 0.431 Max Web CSI: 0.659 VIEW Ver: 21.01.01A.0521.20	Maximum Reactions (lbs) Gravity Loc R+ / R- / Rh / Rw / U / RL Non-Gravity A 153 - / - / /156 /39 /233 W 1466 - / - / /1015 /171 - O 1579 - / - / /852 /144 - M 397 - / - / /272 /49 - Wind reactions based on MWFRS A Brg Wid = - Min Req = - W Brg Wid = 4.0 Min Req = 1.7 O Brg Wid = 4.0 Min Req = 1.9 M Brg Wid = 4.0 Bearings W, O, & M are a rigid surface. Members not listed have forces less than 375#
--	---	---	--	---

Lumber
Top chord: 2x4 SP #2;
Bot chord: 2x4 SP #2;
Webs: 2x4 SP #3;

Bracing
(a) Continuous lateral restraint equally spaced on member.

Plating Notes
All plates are 3X4 except as noted.

Hangers / Ties
(J) Hanger Support Required, by others

Wind
Wind loads based on MWFRS with additional C&C member design.
Right end vertical not exposed to wind pressure.
Uplifts based on an elevation at or above 1000 ft.

Additional Notes
The overall height of this truss excluding overhang is 11-0-0.

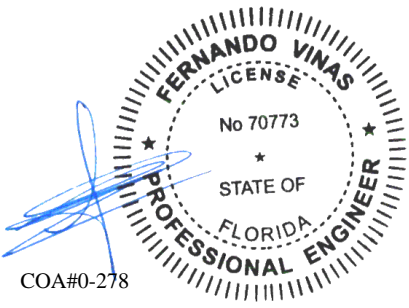

COA#0-278
02/28/2022

Maximum Top Chord Forces Per Ply (lbs)

Chords	Tens.Comp.	Chords	Tens. Comp.
B - C	321 - 1512	E - F	326 - 656
C - D	389 - 1408	F - G	326 - 656
D - E	381 - 1064		

Maximum Bot Chord Forces Per Ply (lbs)

Chords	Tens.Comp.	Chords	Tens. Comp.
U - T	1294 - 355	S - R	881 - 225
T - S	1185 - 330		

Maximum Web Forces Per Ply (lbs)

Webs	Tens.Comp.	Webs	Tens. Comp.
V - W	414 - 1417	F - R	159 - 377
V - B	422 - 1366	R - G	1029 - 278
B - U	1373 - 356	G - Q	272 - 1001
D - S	171 - 493	Q - H	1067 - 247
E - S	516 - 116	H - P	317 - 1248
E - R	122 - 446	P - O	327 - 1264

****WARNING** READ AND FOLLOW ALL NOTES ON THIS DRAWING!**
****IMPORTANT** FURNISH THIS DRAWING TO ALL CONTRACTORS INCLUDING THE INSTALLERS**
Trusses require extreme care in fabricating, handling, shipping, installing and bracing. Refer to and follow the latest edition of BCSI (Building Component Safety Information, by TPI and SBCA) for safety practices prior to performing these functions. Installers shall provide temporary bracing per BCSI. Unless noted otherwise, top chord shall have properly attached structural sheathing and bottom chord shall have a properly attached rigid ceiling. Locations shown for permanent lateral restraint of webs shall have bracing installed per BCSI sections B3, B7, or B10, as applicable. Apply plates to each face of truss and position as shown above and on the Joint Details, unless noted otherwise. Refer to drawings 160A-Z for standard plate positions. Refer to job's General Notes page for additional information.
Alpine, a division of ITW Building Components Group Inc. shall not be responsible for any deviation from this drawing, any failure to build the truss in conformance with ANSI/TPI 1, or for handling, shipping, installation and bracing of trusses. A seal on this drawing or cover page listing this drawing, indicates acceptance of professional engineering responsibility solely for the design shown. The suitability and use of this drawing for any structure is the responsibility of the Building Designer per ANSI/TPI 1 Sec.2.
For more information see these web sites: Alpine: alpineitw.com; TPI: tpinst.org; SBCA: sbccomponents.com; ICC: iccsafe.org; AWC: awc.org



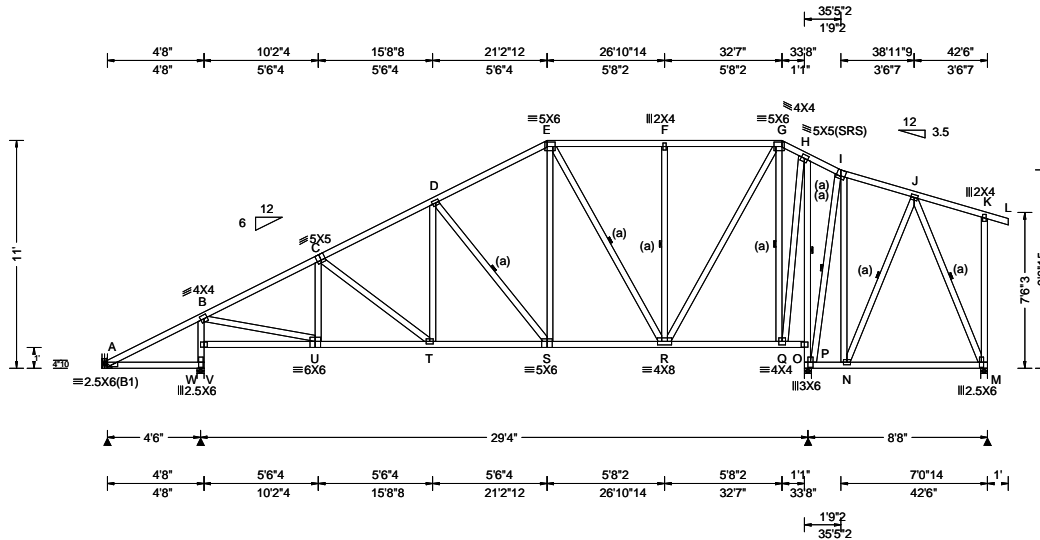

Loading Criteria (psf) TCLL: 20.00 TCDL: 10.00 BCLL: 0.00 BCDL: 10.00 Des Ld: 40.00 NCBCLL: 10.00 Soffit: 2.00 Load Duration: 1.25 Spacing: 24.0 "	Wind Criteria Wind Std: ASCE 7-10 Speed: 130 mph Enclosure: Closed Risk Category: II EXP: C Kzt: NA Mean Height: 15.00 ft TCDL: 5.0 psf BCDL: 5.0 psf MWFRS Parallel Dist: h to 2h C&C Dist a: 4.25 ft Loc. from endwall: not in 13.00 ft GCp: 0.18 Wind Duration: 1.60	Snow Criteria (Pg,Pf in PSF) Pg: NA Ct: NA CAT: NA Pf: NA Ce: NA Lu: NA Cs: NA Snow Duration: NA Building Code: FBC 2017 RES TPI Std: 2014 Rep Fac: Yes FT/RT:20(0)/10(0) Plate Type(s): WAVE	Defl/CSI Criteria PP Deflection in loc L/def L/# VERT(LL): 0.061 T 999 240 VERT(CL): 0.124 T 999 180 HORZ(LL): 0.019 M - - HORZ(TL): 0.039 M - - Creep Factor: 2.0 Max TC CSI: 0.455 Max BC CSI: 0.431 Max Web CSI: 0.659 VIEW Ver: 21.01.01A.0521.20	Maximum Reactions (lbs) <table border="1" style="width:100%; border-collapse: collapse;"> <thead> <tr> <th rowspan="2">Loc</th> <th colspan="3">Gravity</th> <th colspan="3">Non-Gravity</th> </tr> <tr> <th>R+</th> <th>/R-</th> <th>/Rh</th> <th>/Rw</th> <th>/U</th> <th>/RL</th> </tr> </thead> <tbody> <tr> <td>A</td> <td>153</td> <td>-</td> <td>-</td> <td>/156</td> <td>/39</td> <td>/233</td> </tr> <tr> <td>W</td> <td>1466</td> <td>-</td> <td>-</td> <td>/1015</td> <td>/171</td> <td>-</td> </tr> <tr> <td>O</td> <td>1579</td> <td>-</td> <td>-</td> <td>/852</td> <td>/144</td> <td>-</td> </tr> <tr> <td>M</td> <td>397</td> <td>-</td> <td>-</td> <td>/272</td> <td>/49</td> <td>-</td> </tr> </tbody> </table> Wind reactions based on MWFRS A Brg Wid = - Min Req = - W Brg Wid = 4.0 Min Req = 1.7 O Brg Wid = 4.0 Min Req = 1.9 M Brg Wid = 4.0 Bearings W, O, & M are a rigid surface. Members not listed have forces less than 375#	Loc	Gravity			Non-Gravity			R+	/R-	/Rh	/Rw	/U	/RL	A	153	-	-	/156	/39	/233	W	1466	-	-	/1015	/171	-	O	1579	-	-	/852	/144	-	M	397	-	-	/272	/49	-
Loc	Gravity			Non-Gravity																																									
	R+	/R-	/Rh	/Rw	/U	/RL																																							
A	153	-	-	/156	/39	/233																																							
W	1466	-	-	/1015	/171	-																																							
O	1579	-	-	/852	/144	-																																							
M	397	-	-	/272	/49	-																																							

Lumber
Top chord: 2x4 SP #2;
Bot chord: 2x4 SP #2;
Webs: 2x4 SP #3;

Bracing
(a) Continuous lateral restraint equally spaced on member.

Plating Notes
All plates are 3X4 except as noted.

Hangers / Ties
(J) Hanger Support Required, by others

Wind
Wind loads based on MWFRS with additional C&C member design.
Right end vertical not exposed to wind pressure.
Uplifts based on an elevation at or above 1000 ft.

Additional Notes
The overall height of this truss excluding overhang is 11-0-0.

Maximum Top Chord Forces Per Ply (lbs)

Chords	Tens.Comp.	Chords	Tens. Comp.
B - C	321 - 1512	E - F	326 - 656
C - D	389 - 1408	F - G	326 - 656
D - E	381 - 1064		

Maximum Bot Chord Forces Per Ply (lbs)

Chords	Tens.Comp.	Chords	Tens. Comp.
U - T	1294 - 355	S - R	881 - 225
T - S	1185 - 330		

Maximum Web Forces Per Ply (lbs)

Webs	Tens.Comp.	Webs	Tens. Comp.
V - W	414 - 1417	F - R	159 - 377
V - B	422 - 1366	R - G	1029 - 278
B - U	1373 - 356	G - Q	272 - 1001
D - S	171 - 493	Q - H	1067 - 247
E - S	516 - 116	H - P	317 - 1248
E - R	122 - 446	P - O	327 - 1264

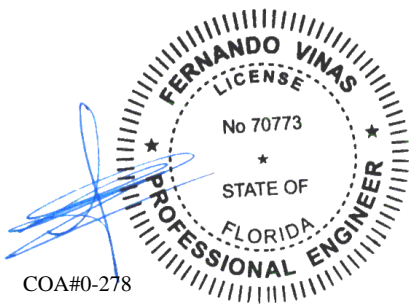

02/28/2022

****WARNING** READ AND FOLLOW ALL NOTES ON THIS DRAWING!**
****IMPORTANT** FURNISH THIS DRAWING TO ALL CONTRACTORS INCLUDING THE INSTALLERS**
Trusses require extreme care in fabricating, handling, shipping, installing and bracing. Refer to and follow the latest edition of BCSI (Building Component Safety Information, by TPI and SBCA) for safety practices prior to performing these functions. Installers shall provide temporary bracing per BCSI. Unless noted otherwise, top chord shall have properly attached structural sheathing and bottom chord shall have a properly attached rigid ceiling. Locations shown for permanent lateral restraint of webs shall have bracing installed per BCSI sections B3, B7, or B10, as applicable. Apply plates to each face of truss and position as shown above and on the Joint Details, unless noted otherwise. Refer to drawings 160A-Z for standard plate positions. Refer to job's General Notes page for additional information.
Alpine, a division of ITW Building Components Group Inc. shall not be responsible for any deviation from this drawing, any failure to build the truss in conformance with ANSI/TPI 1, or for handling, shipping, installation and bracing of trusses. A seal on this drawing or cover page listing this drawing, indicates acceptance of professional engineering responsibility solely for the design shown. The suitability and use of this drawing for any structure is the responsibility of the Building Designer per ANSI/TPI 1 Sec.2.
For more information see these web sites: Alpine: alpineitw.com; TPI: tpinst.org; SBCA: sbccomponents.com; ICC: iccsafe.org; AWC: awc.org



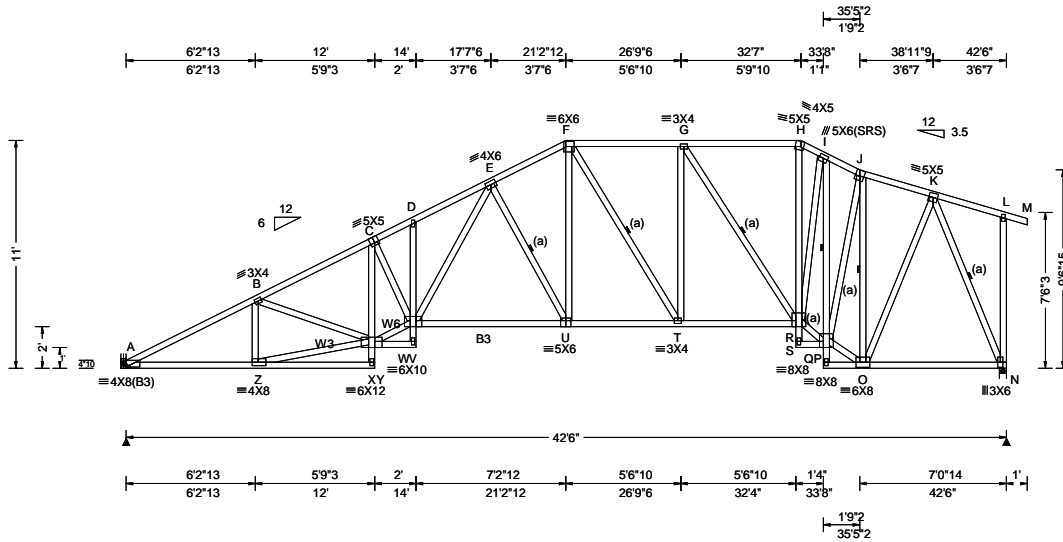

Loading Criteria (psf) TCLL: 20.00 TCDL: 10.00 BCLL: 0.00 BCDL: 10.00 Des Ld: 40.00 NCBCLL: 10.00 Soffit: 2.00 Load Duration: 1.25 Spacing: 24.0 "	Wind Criteria Wind Std: ASCE 7-10 Speed: 130 mph Enclosure: Closed Risk Category: II EXP: C Kzt: NA Mean Height: 15.00 ft TCDL: 5.0 psf BCDL: 5.0 psf MWFRS Parallel Dist: > 2h C&C Dist a: 4.25 ft Loc. from endwall: not in 13.00 ft GCp: 0.18 Wind Duration: 1.60	Snow Criteria (Pg, Pf in PSF) Pg: NA Ct: NA CAT: NA Pf: NA Ce: NA Lu: NA Cs: NA Snow Duration: NA Building Code: FBC 2017 RES TPI Std: 2014 Rep Fac: Yes FT/RT:20(0)/10(0) Plate Type(s): WAVE	Defl/CSI Criteria PP Deflection in loc L/def L/# VERT(LL): 0.325 V 999 240 VERT(CL): 0.587 V 865 180 HORZ(LL): 0.183 N - - HORZ(TL): 0.330 N - - Creep Factor: 2.0 Max TC CSI: 0.588 Max BC CSI: 0.935 Max Web CSI: 0.877 VIEW Ver: 21.01.01A.0521.20	▲ Maximum Reactions (lbs) Gravity Non-Gravity Loc R+ / R- / Rh / Rw / U / RL A 1922 - / - / - /1095 /117 /233 N 2102 - / - / - /943 /181 - /- Wind reactions based on MWFRS A Brg Wid = - Min Req = - N Brg Wid = 4.0 Bearing N is a rigid surface. Members not listed have forces less than 375# Maximum Top Chord Forces Per Ply (lbs) Chords Tens.Comp. Chords Tens. Comp. A - B 772 -3682 F - G 692 -2354 B - C 912 -3991 G - H 577 -1825 C - D 1044 -4319 H - I 608 -1991 D - E 1082 -4320 I - J 545 -1799 E - F 775 -2857 J - K 402 -1382
--	--	--	--	---

Lumber
Top chord: 2x4 SP #2;
Bot chord: 2x4 SP #2; B3 2x4 SP M-31;
Webs: 2x4 SP #3; W3, W6 2x4 SP #2;

Bracing
(a) Continuous lateral restraint equally spaced on member.

Plating Notes
All plates are 2X4 except as noted.

Hangers / Ties
(J) Hanger Support Required, by others

Loading
Truss passed check for 20 psf additional bottom chord live load in areas with 42"-high x 24"-wide clearance.

Wind
Wind loads based on MWFRS with additional C&C member design.
Right end vertical not exposed to wind pressure.
Uplifts based on an elevation at or above 1000 ft.

Additional Notes
The overall height of this truss excluding overhang is 11'-0".

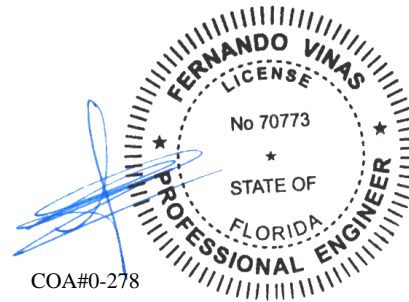

Maximum Bot Chord Forces Per Ply (lbs)

Chords	Tens.Comp.	Chords	Tens. Comp.
A - Z	3214 -805	T - R	2343 -530
V - U	3049 -732	O - N	783 -196
U - T	2510 -563		

Maximum Web Forces Per Ply (lbs)

Webs	Tens.Comp.	Webs	Tens. Comp.
B - Z	200 -600	R - H	599 -155
Z - X	3198 -804	R - I	1497 -309
X - C	264 -1041	R - P	1914 -436
X - V	3887 -936	I - P	334 -1518
C - V	660 -129	P - J	1216 -289
V - E	1607 -392	P - O	1583 -362
E - U	354 -1133	J - O	481 -1810
F - U	1229 -273	O - K	1333 -274
T - G	416 -75	K - N	501 -2004
G - R	209 -941		

****WARNING** READ AND FOLLOW ALL NOTES ON THIS DRAWING!**
****IMPORTANT** FURNISH THIS DRAWING TO ALL CONTRACTORS INCLUDING THE INSTALLERS**
Trusses require extreme care in fabricating, handling, shipping, installing and bracing. Refer to and follow the latest edition of BCSI (Building Component Safety Information, by TPI and SBCA) for safety practices prior to performing these functions. Installers shall provide temporary bracing per BCSI. Unless noted otherwise, top chord shall have properly attached structural sheathing and bottom chord shall have a properly attached rigid ceiling. Locations shown for permanent lateral restraint of webs shall have bracing installed per BCSI sections B3, B7, or B10, as applicable. Apply plates to each face of truss and position as shown above and on the Joint Details, unless noted otherwise. Refer to drawings 160A-Z for standard plate positions. Refer to job's General Notes page for additional information.
Alpine, a division of ITW Building Components Group Inc. shall not be responsible for any deviation from this drawing, any failure to build the truss in conformance with ANSI/TPI 1, or for handling, shipping, installation and bracing of trusses. A seal on this drawing or cover page listing this drawing, indicates acceptance of professional engineering responsibility solely for the design shown. The suitability and use of this drawing for any structure is the responsibility of the Building Designer per ANSI/TPI 1 Sec.2.
For more information see these web sites: Alpine: alpineitw.com; TPI: tpinst.org; SBCA: sbccomponents.com; ICC: iccsafe.org; AWC: awc.org



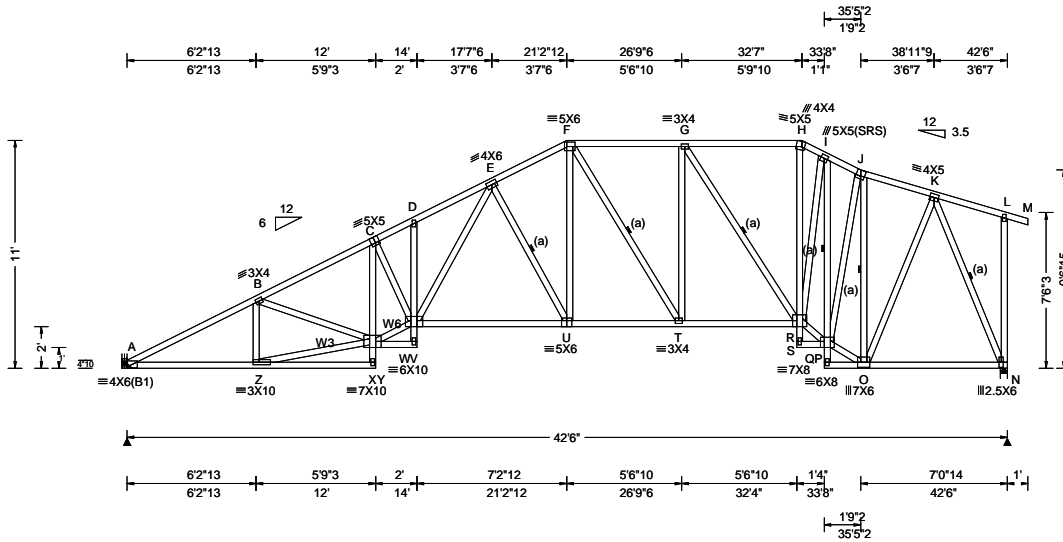

Loading Criteria (psf) TCCL: 20.00 TCDL: 10.00 BCLL: 0.00 BCDL: 10.00 Des Ld: 40.00 NCBCLL: 10.00 Soffit: 2.00 Load Duration: 1.25 Spacing: 24.0 "	Wind Criteria Wind Std: ASCE 7-10 Speed: 130 mph Enclosure: Closed Risk Category: II EXP: C Kzt: NA Mean Height: 15.00 ft TCCL: 5.0 psf BCDL: 5.0 psf MWFRS Parallel Dist: > 2h C&C Dist a: 4.25 ft Loc. from endwall: not in 13.00 ft GCp: 0.18 Wind Duration: 1.60	Snow Criteria (Pg,Pf in PSF) Pg: NA Ct: NA CAT: NA Pf: NA Ce: NA Lu: NA Cs: NA Snow Duration: NA Building Code: FBC 2017 RES TPI Std: 2014 Rep Fac: Yes FT/RT:20(0)/10(0) Plate Type(s): WAVE	Defl/CSI Criteria PP Deflection in loc L/defl L/# VERT(LL): 0.257 V 999 240 VERT(CL): 0.523 V 972 180 HORZ(LL): 0.147 N - - HORZ(TL): 0.298 N - - Creep Factor: 2.0 Max TC CSI: 0.493 Max BC CSI: 0.855 Max Web CSI: 0.768 VIEW Ver: 21.01.01A.0521.20	▲ Maximum Reactions (lbs) <table style="width:100%; border-collapse: collapse;"> <thead> <tr> <th rowspan="2">Loc</th> <th colspan="3">Gravity</th> <th colspan="3">Non-Gravity</th> </tr> <tr> <th>R+</th> <th>/R-</th> <th>/Rh</th> <th>/Rw</th> <th>/U</th> <th>/RL</th> </tr> </thead> <tbody> <tr> <td>A</td> <td>1747</td> <td>-</td> <td>-</td> <td>/1095</td> <td>/117</td> <td>/233</td> </tr> <tr> <td>N</td> <td>1790</td> <td>-</td> <td>-</td> <td>/943</td> <td>/181</td> <td>-</td> </tr> </tbody> </table> Wind reactions based on MWFRS A Brg Wid = - Min Req = - N Brg Wid = 4.0 Bearing N is a rigid surface. Members not listed have forces less than 375# Maximum Top Chord Forces Per Ply (lbs) <table style="width:100%; border-collapse: collapse;"> <thead> <tr> <th>Chords</th> <th>Tens.Comp.</th> <th>Chords</th> <th>Tens. Comp.</th> </tr> </thead> <tbody> <tr> <td>A - B</td> <td>772 - 3313</td> <td>F - G</td> <td>692 - 1989</td> </tr> <tr> <td>B - C</td> <td>912 - 3518</td> <td>G - H</td> <td>577 - 1557</td> </tr> <tr> <td>C - D</td> <td>1044 - 3764</td> <td>H - I</td> <td>608 - 1697</td> </tr> <tr> <td>D - E</td> <td>1082 - 3765</td> <td>I - J</td> <td>542 - 1532</td> </tr> <tr> <td>E - F</td> <td>775 - 2428</td> <td>J - K</td> <td>402 - 1175</td> </tr> </tbody> </table>	Loc	Gravity			Non-Gravity			R+	/R-	/Rh	/Rw	/U	/RL	A	1747	-	-	/1095	/117	/233	N	1790	-	-	/943	/181	-	Chords	Tens.Comp.	Chords	Tens. Comp.	A - B	772 - 3313	F - G	692 - 1989	B - C	912 - 3518	G - H	577 - 1557	C - D	1044 - 3764	H - I	608 - 1697	D - E	1082 - 3765	I - J	542 - 1532	E - F	775 - 2428	J - K	402 - 1175
Loc	Gravity			Non-Gravity																																																			
	R+	/R-	/Rh	/Rw	/U	/RL																																																	
A	1747	-	-	/1095	/117	/233																																																	
N	1790	-	-	/943	/181	-																																																	
Chords	Tens.Comp.	Chords	Tens. Comp.																																																				
A - B	772 - 3313	F - G	692 - 1989																																																				
B - C	912 - 3518	G - H	577 - 1557																																																				
C - D	1044 - 3764	H - I	608 - 1697																																																				
D - E	1082 - 3765	I - J	542 - 1532																																																				
E - F	775 - 2428	J - K	402 - 1175																																																				

Lumber
 Top chord: 2x4 SP #2;
 Bot chord: 2x4 SP #2;
 Webs: 2x4 SP #3; W3,W6 2x4 SP #2;

Bracing
 (a) Continuous lateral restraint equally spaced on member.

Plating Notes
 All plates are 2X4 except as noted.

Hangers / Ties
 (J) Hanger Support Required, by others

Wind
 Wind loads based on MWFRS with additional C&C member design.
 Right end vertical not exposed to wind pressure.
 Uplifts based on an elevation at or above 1000 ft.

Additional Notes
 The overall height of this truss excluding overhang is 11'-0".

Maximum Bot Chord Forces Per Ply (lbs)

Chords	Tens.Comp.	Chords	Tens. Comp.
A - Z	2886 - 805	T - R	1983 - 530
V - U	2623 - 731	O - N	670 - 196
U - T	2127 - 563		

Maximum Web Forces Per Ply (lbs)

Webs	Tens.Comp.	Webs	Tens. Comp.
B - Z	201 - 523	R - H	474 - 155
Z - X	2872 - 804	R - I	1329 - 324
X - C	264 - 864	R - P	1652 - 442
X - V	3404 - 937	I - P	349 - 1349
C - V	508 - 129	P - J	1049 - 279
V - E	1457 - 393	P - O	1314 - 356
E - U	354 - 1045	J - O	470 - 1581
F - U	1007 - 273	O - K	1108 - 275
G - R	209 - 773	K - N	501 - 1716

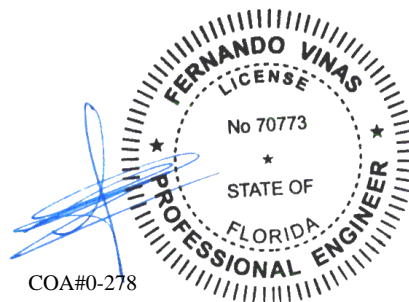

COA#0-278

02/28/2022

****WARNING** READ AND FOLLOW ALL NOTES ON THIS DRAWING!**
****IMPORTANT** FURNISH THIS DRAWING TO ALL CONTRACTORS INCLUDING THE INSTALLERS**
 Trusses require extreme care in fabricating, handling, shipping, installing and bracing. Refer to and follow the latest edition of BCSI (Building Component Safety Information, by TPI and SBCA) for safety practices prior to performing these functions. Installers shall provide temporary bracing per BCSI. Unless noted otherwise, top chord shall have properly attached structural sheathing and bottom chord shall have a properly attached rigid ceiling. Locations shown for permanent lateral restraint of webs shall have bracing installed per BCSI sections B3, B7, or B10, as applicable. Apply plates to each face of truss and position as shown above and on the Joint Details, unless noted otherwise. Refer to drawings 160A-Z for standard plate positions. Refer to job's General Notes page for additional information.
 Alpine, a division of ITW Building Components Group Inc. shall not be responsible for any deviation from this drawing, any failure to build the truss in conformance with ANSI/TPI 1, or for handling, shipping, installation and bracing of trusses. A seal on this drawing or cover page listing this drawing, indicates acceptance of professional engineering responsibility solely for the design shown. The suitability and use of this drawing for any structure is the responsibility of the Building Designer per ANSI/TPI 1 Sec.2.
 For more information see these web sites: Alpine: alpineitw.com; TPI: tpinst.org; SBCA: sbccomponents.com; ICC: iccsafe.org; AWC: awc.org



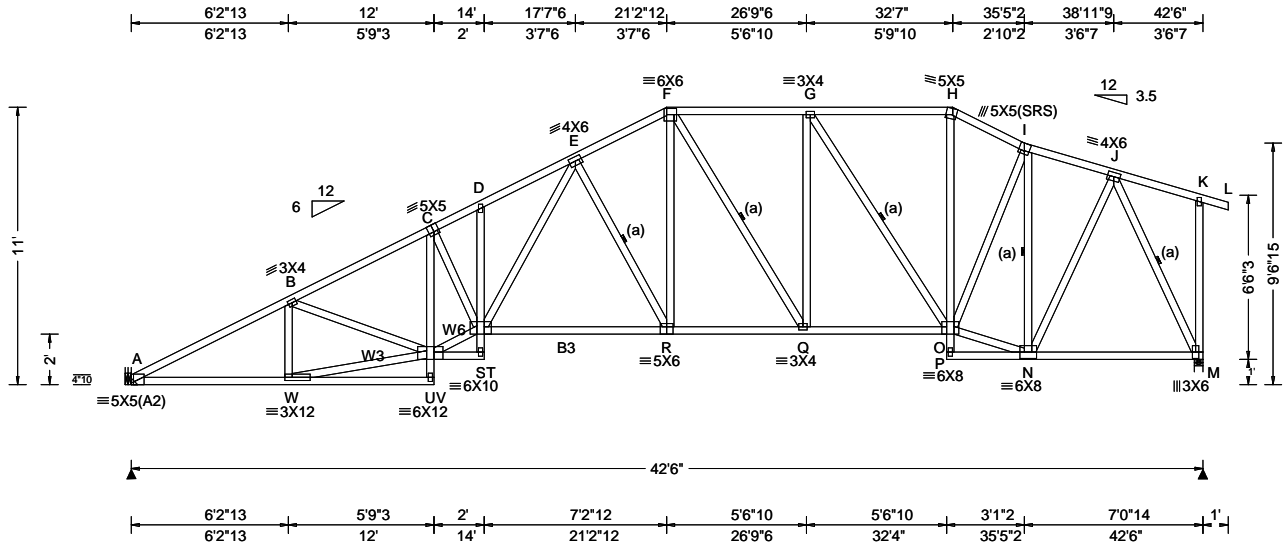

Loading Criteria (psf) TCLL: 20.00 TCDL: 10.00 BCLL: 0.00 BCDL: 10.00 Des Ld: 40.00 NCBCLL: 10.00 Soffit: 2.00 Load Duration: 1.25 Spacing: 24.0 "	Wind Criteria Wind Std: ASCE 7-10 Speed: 130 mph Enclosure: Closed Risk Category: II EXP: C Kzt: NA Mean Height: 15.00 ft TCDL: 5.0 psf BCDL: 5.0 psf MWFRS Parallel Dist: > 2h C&C Dist a: 4.25 ft Loc. from endwall: not in 13.00 ft GCpi: 0.18 Wind Duration: 1.60	Snow Criteria (Pg,Pf in PSF) Pg: NA Ct: NA CAT: NA Pf: NA Ce: NA Lu: NA Cs: NA Snow Duration: NA Building Code: FBC 2017 RES TPI Std: 2014 Rep Fac: Yes FT/RT:20(0)/10(0) Plate Type(s): WAVE	Defl/CSI Criteria PP Deflection in loc L/def L/# VERT(LL): 0.309 S 999 240 VERT(CL): 0.560 S 907 180 HORZ(LL): 0.140 M - - HORZ(TL): 0.253 M - - Creep Factor: 2.0 Max TC CSI: 0.581 Max BC CSI: 0.934 Max Web CSI: 0.876 VIEW Ver: 21.01.01A.0521.20	Maximum Reactions (lbs) Gravity Loc R+ / R- / Rh / Rw / U / RL Non-Gravity A 1920 - / - / 1095 / 118 / 233 M 2087 - / - / 943 / 182 - / - Wind reactions based on MWFRS A Brg Wid = - Min Req = - M Brg Wid = 4.0 Bearing M is a rigid surface. Members not listed have forces less than 375# Maximum Top Chord Forces Per Ply (lbs) Chords Tens.Comp. Chords Tens. Comp. A - B 773 -3679 F - G 692 -2349 B - C 904 -3955 G - H 576 -1813 C - D 1044 -4315 H - I 607 -2043 D - E 1083 -4315 I - J 440 -1532 E - F 775 -2853
--	---	---	--	--

Lumber
Top chord: 2x4 SP #2;
Bot chord: 2x4 SP #2; B3 2x4 SP M-31;
Webs: 2x4 SP #3; W3,W6 2x4 SP #2;

Bracing
(a) Continuous lateral restraint equally spaced on member.

Plating Notes
All plates are 2X4 except as noted.

Hangers / Ties
(J) Hanger Support Required, by others

Loading
Truss passed check for 20 psf additional bottom chord live load in areas with 42"-high x 24"-wide clearance.

Wind
Wind loads based on MWFRS with additional C&C member design.
Right end vertical not exposed to wind pressure.
Uplifts based on an elevation at or above 1000 ft.

Additional Notes
The overall height of this truss excluding overhang is 11'-0".

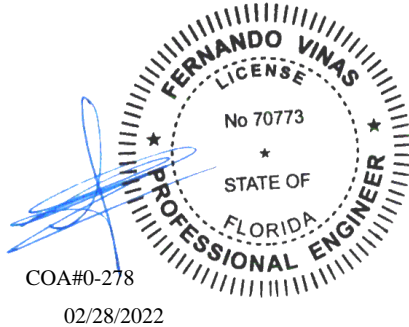

Maximum Bot Chord Forces Per Ply (lbs)			
Chords	Tens.Comp.	Chords	Tens. Comp.
A - W	3211 -805	Q - O	2337 -530
S - R	3046 -732	N - M	885 -223
R - Q	2507 -564		
Maximum Web Forces Per Ply (lbs)			
Webs	Tens.Comp.	Webs	Tens. Comp.
B - W	195 -576	Q - G	432 -74
W - U	3188 -803	G - O	211 -956
U - C	281 -1112	O - H	625 -146
U - S	3881 -936	O - I	895 -194
C - S	722 -145	O - N	1552 -355
S - E	1606 -392	I - N	389 -1461
E - R	354 -1132	N - J	1288 -268
F - R	1229 -273	J - M	512 -2034

****WARNING** READ AND FOLLOW ALL NOTES ON THIS DRAWING!**
****IMPORTANT** FURNISH THIS DRAWING TO ALL CONTRACTORS INCLUDING THE INSTALLERS**
Trusses require extreme care in fabricating, handling, shipping, installing and bracing. Refer to and follow the latest edition of BCSI (Building Component Safety Information, by TPI and SBCA) for safety practices prior to performing these functions. Installers shall provide temporary bracing per BCSI. Unless noted otherwise, top chord shall have properly attached structural sheathing and bottom chord shall have a properly attached rigid ceiling. Locations shown for permanent lateral restraint of webs shall have bracing installed per BCSI sections B3, B7, or B10, as applicable. Apply plates to each face of truss and position as shown above and on the Joint Details, unless noted otherwise. Refer to drawings 160A-Z for standard plate positions. Refer to job's General Notes page for additional information.
Alpine, a division of ITW Building Components Group Inc. shall not be responsible for any deviation from this drawing, any failure to build the truss in conformance with ANSI/TPI 1, or for handling, shipping, installation and bracing of trusses. A seal on this drawing or cover page listing this drawing, indicates acceptance of professional engineering responsibility solely for the design shown. The suitability and use of this drawing for any structure is the responsibility of the Building Designer per ANSI/TPI 1 Sec.2.
For more information see these web sites: Alpine: alpineitw.com; TPI: tpinst.org; SBCA: sbccomponents.com; ICC: iccsafe.org; AWC: awc.org



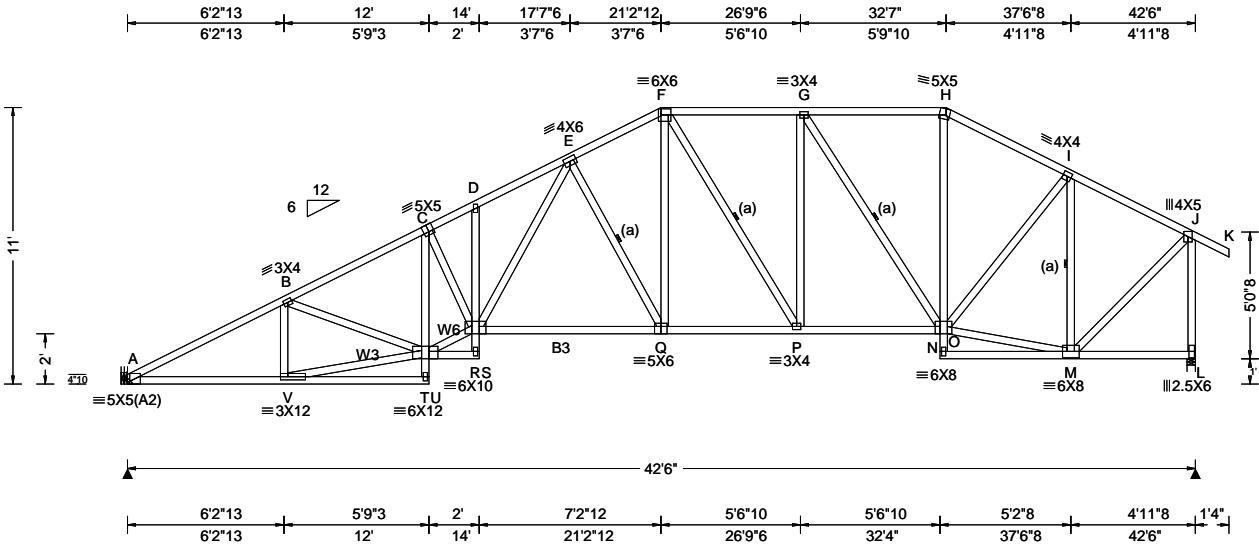

Loading Criteria (psf) TCLL: 20.00 TCDL: 10.00 BCLL: 0.00 BCDL: 10.00 Des Ld: 40.00 NCBCLL: 10.00 Soffit: 2.00 Load Duration: 1.25 Spacing: 24.0 "	Wind Criteria Wind Std: ASCE 7-10 Speed: 130 mph Enclosure: Closed Risk Category: II EXP: C Kzt: NA Mean Height: 15.00 ft TCDL: 5.0 psf BCDL: 5.0 psf MWFRS Parallel Dist: > 2h C&C Dist a: 4.25 ft Loc. from endwall: not in 13.00 ft GCpi: 0.18 Wind Duration: 1.60	Snow Criteria (Pg,Pf in PSF) Pg: NA Ct: NA CAT: NA Pf: NA Ce: NA Lu: NA Cs: NA Snow Duration: NA Building Code: FBC 2017 RES TPI Std: 2014 Rep Fac: Yes FT/RT:20(0)/10(0) Plate Type(s): WAVE	Defl/CSI Criteria PP Deflection in loc L/def L/# VERT(LL): 0.296 R 999 240 VERT(CL): 0.554 R 917 180 HORZ(LL): 0.128 M - - HORZ(TL): 0.239 M - - Creep Factor: 2.0 Max TC CSI: 0.580 Max BC CSI: 0.932 Max Web CSI: 0.940 VIEW Ver: 21.01.01A.0521.20	▲ Maximum Reactions (lbs) Gravity Non-Gravity Loc R+ / R- / Rh / Rw / U / RL A 1917 /- /- /1088 /110 /265 L 2026 /- /- /992 /115 /- Wind reactions based on MWFRS A Brg Wid = - Min Req = - L Brg Wid = 4.0 Bearing L is a rigid surface. Members not listed have forces less than 375# Maximum Top Chord Forces Per Ply (lbs) Chords Tens.Comp. Chords Tens. Comp. A - B 778 -3673 F - G 667 -2337 B - C 878 -3947 G - H 551 -1792 C - D 1002 -4305 H - I 582 -2064 D - E 1041 -4306 I - J 393 -1414 E - F 750 -2845
--	---	---	--	---

Lumber
Top chord: 2x4 SP #2;
Bot chord: 2x4 SP #2; B3 2x4 SP M-31;
Webs: 2x4 SP #3; W3,W6 2x4 SP #2;

Bracing
(a) Continuous lateral restraint equally spaced on member.

Plating Notes
All plates are 2X4 except as noted.

Hangers / Ties
(J) Hanger Support Required, by others

Loading
Truss passed check for 20 psf additional bottom chord live load in areas with 42"-high x 24"-wide clearance.

Wind
Wind loads based on MWFRS with additional C&C member design.
Right end vertical not exposed to wind pressure.
Uplifts based on an elevation at or above 1000 ft.

Additional Notes
The overall height of this truss excluding overhang is 11'-0".

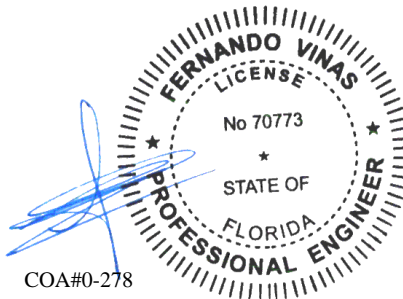

COA#0-278

02/28/2022

****WARNING** READ AND FOLLOW ALL NOTES ON THIS DRAWING!**
****IMPORTANT** FURNISH THIS DRAWING TO ALL CONTRACTORS INCLUDING THE INSTALLERS**
Trusses require extreme care in fabricating, handling, shipping, installing and bracing. Refer to and follow the latest edition of BCSI (Building Component Safety Information, by TPI and SBCA) for safety practices prior to performing these functions. Installers shall provide temporary bracing per BCSI. Unless noted otherwise, top chord shall have properly attached structural sheathing and bottom chord shall have a properly attached rigid ceiling. Locations shown for permanent lateral restraint of webs shall have bracing installed per BCSI sections B3, B7, or B10, as applicable. Apply plates to each face of truss and position as shown above and on the Joint Details, unless noted otherwise. Refer to drawings 160A-Z for standard plate positions. Refer to job's General Notes page for additional information.
Alpine, a division of ITW Building Components Group Inc. shall not be responsible for any deviation from this drawing, any failure to build the truss in conformance with ANSI/TPI 1, or for handling, shipping, installation and bracing of trusses. A seal on this drawing or cover page listing this drawing, indicates acceptance of professional engineering responsibility solely for the design shown. The suitability and use of this drawing for any structure is the responsibility of the Building Designer per ANSI/TPI 1 Sec.2.
For more information see these web sites: Alpine: alpineitw.com; TPI: tpinst.org; SBCA: sbcacomponents.com; ICC: iccsafe.org; AWC: awc.org



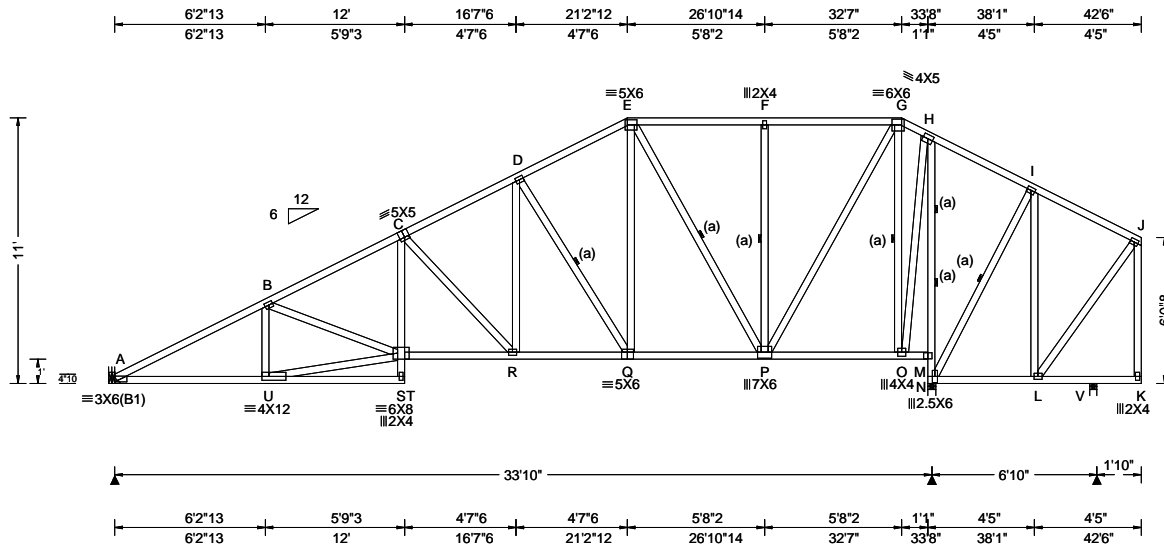

Loading Criteria (psf) TCLL: 20.00 TCDL: 10.00 BCLL: 0.00 BCDL: 10.00 Des Ld: 40.00 NCBCLL: 10.00 Soffit: 2.00 Load Duration: 1.25 Spacing: 24.0 "	Wind Criteria Wind Std: ASCE 7-10 Speed: 130 mph Enclosure: Closed Risk Category: II EXP: C Kzt: NA Mean Height: 16.11 ft TCDL: 5.0 psf BCDL: 5.0 psf MWFRS Parallel Dist: > 2h C&C Dist a: 4.25 ft Loc. from endwall: not in 13.00 ft GCp: 0.18 Wind Duration: 1.60	Snow Criteria (Pg,Pf in PSF) Pg: NA Ct: NA CAT: NA Pf: NA Ce: NA Lu: NA Cs: NA Snow Duration: NA Building Code: FBC 2017 RES TPI Std: 2014 Rep Fac: Yes FT/RT:20(0)/10(0) Plate Type(s): WAVE	Defl/CSI Criteria PP Deflection in loc L/def L/# VERT(LL): 0.132 S 999 240 VERT(CL): 0.276 S 999 180 HORZ(LL): 0.044 P - - HORZ(TL): 0.093 O - - Creep Factor: 2.0 Max TC CSI: 0.389 Max BC CSI: 0.578 Max Web CSI: 0.826 VIEW Ver: 21.01.01A.0521.20	▲ Maximum Reactions (lbs) Gravity Loc R+ / R- / Rh / Rw / U / RL Non-Gravity A 1364 /- /- /891 /15 /245 M 2019 /- /- /1139 /- /- V 185 /- /- /173 /32 /- Wind reactions based on MWFRS A Brg Wid = - Min Req = - M Brg Wid = 4.0 Min Req = 2.4 V Brg Wid = 3.5 Bearings M & V are a rigid surface. Members not listed have forces less than 375# Maximum Top Chord Forces Per Ply (lbs) Chords Tens.Comp. Chords Tens. Comp.
--	--	---	--	--

Lumber

Top chord: 2x4 SP #2;
Bot chord: 2x4 SP #2;
Webs: 2x4 SP #3;

Bracing

(a) Continuous lateral restraint equally spaced on member.

Plating Notes

All plates are 3X4 except as noted.

Wind

Wind loads based on MWFRS with additional C&C member design.

Right end vertical not exposed to wind pressure.

Right cantilever is exposed to wind

Uplifts based on an elevation at or above 1000 ft.

Additional Notes

The overall height of this truss excluding overhang is 11'-0".

Maximum Bot Chord Forces Per Ply (lbs)

Chords	Tens.Comp.	Chords	Tens. Comp.
A - U	2163 -426	R - Q	1516 -193
S - R	2101 -341	Q - P	1070 -64

Maximum Web Forces Per Ply (lbs)

Webs	Tens.Comp.	Webs	Tens. Comp.
U - S	2137 -424	F - P	0 -395
S - C	582 -120	P - G	1329 -96
C - R	228 -841	G - O	0 -1257
R - D	680 -147	O - H	1283 0
D - Q	282 -855	H - N	64 -1622
E - Q	829 -224	N - M	80 -1682
E - P	211 -719		

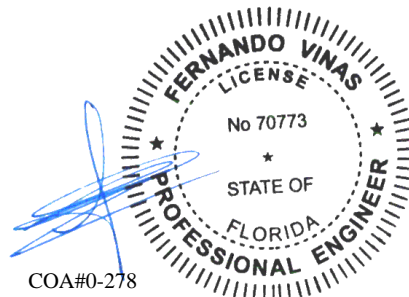

COA#0-278

02/28/2022

****WARNING** READ AND FOLLOW ALL NOTES ON THIS DRAWING!**
****IMPORTANT** FURNISH THIS DRAWING TO ALL CONTRACTORS INCLUDING THE INSTALLERS**
Trusses require extreme care in fabricating, handling, shipping, installing and bracing. Refer to and follow the latest edition of BCSI (Building Component Safety Information, by TPI and SBCA) for safety practices prior to performing these functions. Installers shall provide temporary bracing per BCSI. Unless noted otherwise, top chord shall have properly attached structural sheathing and bottom chord shall have a properly attached rigid ceiling. Locations shown for permanent lateral restraint of webs shall have bracing installed per BCSI sections B3, B7, or B10, as applicable. Apply plates to each face of truss and position as shown above and on the Joint Details, unless noted otherwise. Refer to drawings 160A-Z for standard plate positions. Refer to job's General Notes page for additional information.
Alpine, a division of ITW Building Components Group Inc. shall not be responsible for any deviation from this drawing, any failure to build the truss in conformance with ANSI/TPI 1, or for handling, shipping, installation and bracing of trusses. A seal on this drawing or cover page listing this drawing, indicates acceptance of professional engineering responsibility solely for the design shown. The suitability and use of this drawing for any structure is the responsibility of the Building Designer per ANSI/TPI 1 Sec.2.
For more information see these web sites: Alpine: alpineitw.com; TPI: tpinst.org; SBCA: sbccomponents.com; ICC: iccsafe.org; AWC: awc.org



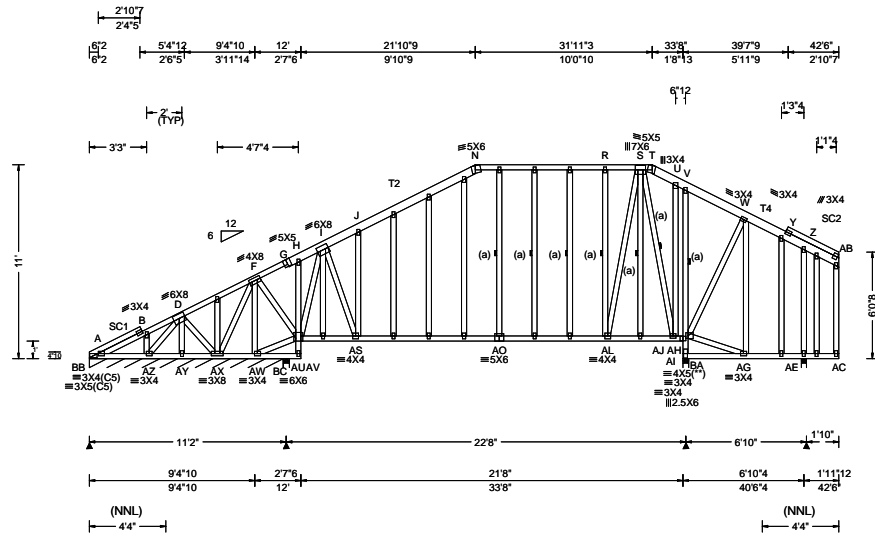

Loading Criteria (psf) TCCL: 20.00 TCCL: 10.00 BCCL: 0.00 BCDL: 10.00 Des Ld: 40.00 NCBCLL: 10.00 Soffit: 2.00 Load Duration: 1.25 Spacing: 24.0 "	Wind Criteria Wind Std: ASCE 7-10 Speed: 130 mph Enclosure: Closed Risk Category: II EXP: C Kzt: NA Mean Height: 15.00 ft TCCL: 5.0 psf BCDL: 5.0 psf MWFRS Parallel Dist: > 2h C&C Dist a: 4.25 ft Loc. from endwall: not in 13.00 ft GCp: 0.18 Wind Duration: 1.60	Snow Criteria (Pg,Pf in PSF) Pg: NA Ct: NA CAT: NA Pf: NA Ce: NA Lu: NA Cs: NA Snow Duration: NA Building Code: FBC 2017 RES TPI Std: 2014 Rep Fac: Yes FT/RT:20(0)/10(0) Plate Type(s): WAVE	Defl/CSI Criteria PP Deflection in loc L/def L/# VERT(LL): 0.325 O 835 240 VERT(CL): 0.669 O 405 180 HORZ(LL): 0.166 AB - - HORZ(TL): 0.351 AB - - Creep Factor: 2.0 Max TC CSI: 0.960 Max BC CSI: 0.995 Max Web CSI: 0.609 VIEW Ver: 21.01.01A.0521.20	▲ Maximum Reactions (lbs), or *=PLF <table border="1"> <thead> <tr> <th rowspan="2">Loc</th> <th colspan="3">Gravity</th> <th colspan="3">Non-Gravity</th> </tr> <tr> <th>R+</th> <th>/R-</th> <th>/Rh</th> <th>/Rw</th> <th>/U</th> <th>/RL</th> </tr> </thead> <tbody> <tr> <td>BB* 149</td> <td>-</td> <td>-</td> <td>-</td> <td>/115</td> <td>-</td> <td>/13</td> </tr> <tr> <td>BC 318</td> <td>-</td> <td>-</td> <td>-</td> <td>/214</td> <td>-</td> <td>-</td> </tr> <tr> <td>AI 1051</td> <td>-</td> <td>-</td> <td>-</td> <td>/580</td> <td>-</td> <td>-</td> </tr> <tr> <td>AE 522</td> <td>-</td> <td>-</td> <td>-</td> <td>/374</td> <td>/6</td> <td>-</td> </tr> <tr> <td>AZ</td> <td colspan="6">-180</td> </tr> <tr> <td>AY</td> <td colspan="6">-133</td> </tr> </tbody> </table> <p>Wind reactions based on MWFRS BB Brg Wid = 132 Min Req = - BC Brg Wid = 4.0 Min Req = 1.5 AI Brg Wid = 4.0 Min Req = 1.5 AE Brg Wid = 3.5 Min Req = 1.5 Bearings BB, BC, AI, & AE are a rigid surface.</p> <p>Members not listed have forces less than 375# Maximum Top Chord Forces Per Ply (lbs)</p> <table border="1"> <thead> <tr> <th>Chords</th> <th>Tens.Comp.</th> <th>Chords</th> <th>Tens. Comp.</th> </tr> </thead> <tbody> <tr> <td>D - F</td> <td>752 0</td> <td>J - N</td> <td>217 -693</td> </tr> <tr> <td>F - G</td> <td>426 0</td> <td>N - R</td> <td>190 -484</td> </tr> <tr> <td>G - H</td> <td>431 0</td> <td>R - S</td> <td>186 -471</td> </tr> <tr> <td>H - I</td> <td>422 0</td> <td>U - V</td> <td>156 -390</td> </tr> <tr> <td>I - J</td> <td>234 -394</td> <td></td> <td></td> </tr> </tbody> </table> <p>Maximum Bot Chord Forces Per Ply (lbs)</p> <table border="1"> <thead> <tr> <th>Chords</th> <th>Tens.Comp.</th> <th>Chords</th> <th>Tens. Comp.</th> </tr> </thead> <tbody> <tr> <td>AZ-AX</td> <td>0 -376</td> <td>AS-AO</td> <td>480 -53</td> </tr> <tr> <td>AX-AW</td> <td>0 -636</td> <td>AO-AL</td> <td>480 -53</td> </tr> </tbody> </table> <p>Maximum Web Forces Per Ply (lbs)</p> <table border="1"> <thead> <tr> <th>Webs</th> <th>Tens.Comp.</th> <th>Webs</th> <th>Tens. Comp.</th> </tr> </thead> <tbody> <tr> <td>D - AX</td> <td>0 -401</td> <td>AL - S</td> <td>1072 -117</td> </tr> <tr> <td>F - AW</td> <td>0 -978</td> <td>S - AJ</td> <td>139 -733</td> </tr> <tr> <td>F - AU</td> <td>807 0</td> <td>AH-AI</td> <td>218 -981</td> </tr> <tr> <td>AW-AU</td> <td>0 -750</td> <td>BA-AH</td> <td>181 -746</td> </tr> <tr> <td>AU - I</td> <td>0 -971</td> <td>BA - V</td> <td>161 -890</td> </tr> <tr> <td>I - AS</td> <td>1161 0</td> <td>Z - AE</td> <td>43 -472</td> </tr> </tbody> </table> <p>Maximum Gable Forces Per Ply (lbs)</p> <table border="1"> <thead> <tr> <th>Gables</th> <th>Tens.Comp.</th> <th>Gables</th> <th>Tens. Comp.</th> </tr> </thead> <tbody> <tr> <td>AS - J</td> <td>0 -804</td> <td>AJ - U</td> <td>454 -78</td> </tr> <tr> <td>R - AL</td> <td>86 -591</td> <td></td> <td></td> </tr> </tbody> </table>	Loc	Gravity			Non-Gravity			R+	/R-	/Rh	/Rw	/U	/RL	BB* 149	-	-	-	/115	-	/13	BC 318	-	-	-	/214	-	-	AI 1051	-	-	-	/580	-	-	AE 522	-	-	-	/374	/6	-	AZ	-180						AY	-133						Chords	Tens.Comp.	Chords	Tens. Comp.	D - F	752 0	J - N	217 -693	F - G	426 0	N - R	190 -484	G - H	431 0	R - S	186 -471	H - I	422 0	U - V	156 -390	I - J	234 -394			Chords	Tens.Comp.	Chords	Tens. Comp.	AZ-AX	0 -376	AS-AO	480 -53	AX-AW	0 -636	AO-AL	480 -53	Webs	Tens.Comp.	Webs	Tens. Comp.	D - AX	0 -401	AL - S	1072 -117	F - AW	0 -978	S - AJ	139 -733	F - AU	807 0	AH-AI	218 -981	AW-AU	0 -750	BA-AH	181 -746	AU - I	0 -971	BA - V	161 -890	I - AS	1161 0	Z - AE	43 -472	Gables	Tens.Comp.	Gables	Tens. Comp.	AS - J	0 -804	AJ - U	454 -78	R - AL	86 -591		
Loc	Gravity			Non-Gravity																																																																																																																																			
	R+	/R-	/Rh	/Rw	/U	/RL																																																																																																																																	
BB* 149	-	-	-	/115	-	/13																																																																																																																																	
BC 318	-	-	-	/214	-	-																																																																																																																																	
AI 1051	-	-	-	/580	-	-																																																																																																																																	
AE 522	-	-	-	/374	/6	-																																																																																																																																	
AZ	-180																																																																																																																																						
AY	-133																																																																																																																																						
Chords	Tens.Comp.	Chords	Tens. Comp.																																																																																																																																				
D - F	752 0	J - N	217 -693																																																																																																																																				
F - G	426 0	N - R	190 -484																																																																																																																																				
G - H	431 0	R - S	186 -471																																																																																																																																				
H - I	422 0	U - V	156 -390																																																																																																																																				
I - J	234 -394																																																																																																																																						
Chords	Tens.Comp.	Chords	Tens. Comp.																																																																																																																																				
AZ-AX	0 -376	AS-AO	480 -53																																																																																																																																				
AX-AW	0 -636	AO-AL	480 -53																																																																																																																																				
Webs	Tens.Comp.	Webs	Tens. Comp.																																																																																																																																				
D - AX	0 -401	AL - S	1072 -117																																																																																																																																				
F - AW	0 -978	S - AJ	139 -733																																																																																																																																				
F - AU	807 0	AH-AI	218 -981																																																																																																																																				
AW-AU	0 -750	BA-AH	181 -746																																																																																																																																				
AU - I	0 -971	BA - V	161 -890																																																																																																																																				
I - AS	1161 0	Z - AE	43 -472																																																																																																																																				
Gables	Tens.Comp.	Gables	Tens. Comp.																																																																																																																																				
AS - J	0 -804	AJ - U	454 -78																																																																																																																																				
R - AL	86 -591																																																																																																																																						

Lumber
 Top chord: 2x4 SP #2; T2,T4 2x6 SP #2;
 Bot chord: 2x4 SP #2;
 Webs: 2x4 SP #3;
 Stack Chord: SC1 2x4 SP #2;
 Stack Chord: SC2 2x4 SP #2;

Bracing
 (a) Continuous lateral restraint equally spaced on member.

Plating Notes
 All plates are 2X4 except as noted.
 (** 1 plate(s) require special positioning. Refer to scaled plate plot details for special positioning requirements.

Loading
 Gable end supports 8" max rake overhang. Top chord must not be cut or notched.

Wind
 Wind loads based on MWFRS with additional C&C member design.
 Right end vertical not exposed to wind pressure.
 Right cantilever is exposed to wind
 Uplifts based on an elevation at or above 1000 ft.

Additional Notes
 See DWGS A14015ENC101014 & GBLLETIN0118 for gable wind bracing and other requirements.
 Stacked top chord must NOT be notched or cut in area (NLL). Dropped top chord braced at 24" oc intervals. Attach stacked top chord (SC) to dropped top chord in notchable area using 3x4 tie-plates 24" oc. Center plate on stacked/dropped chord interface, plate length perpendicular to chord length. Splice top chord in notchable area using 3x6.
 The overall height of this truss excluding overhang is 11-0-0.

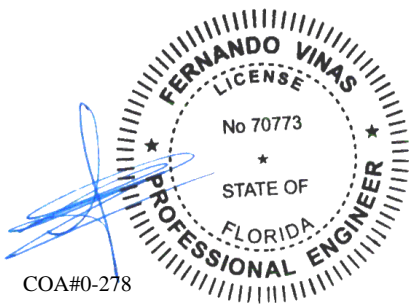

****WARNING** READ AND FOLLOW ALL NOTES ON THIS DRAWING!**
****IMPORTANT** FURNISH THIS DRAWING TO ALL CONTRACTORS INCLUDING THE INSTALLERS**
 Trusses require extreme care in fabricating, handling, shipping, installing and bracing. Refer to and follow the latest edition of BCSI (Building Component Safety Information, by TPI and SBCA) for safety practices prior to performing these functions. Installers shall provide temporary bracing per BCSI. Unless noted otherwise, top chord shall have properly attached structural sheathing and bottom chord shall have a properly attached rigid ceiling. Locations shown for permanent lateral restraint of webs shall have bracing installed per BCSI sections B3, B7, or B10, as applicable. Apply plates to each face of truss and position as shown above and on the Joint Details, unless noted otherwise. Refer to drawings 160A-Z for standard plate positions. Refer to job's General Notes page for additional information.

Alpine, a division of ITW Building Components Group Inc. shall not be responsible for any deviation from this drawing, any failure to build the truss in conformance with ANSI/TPI 1, or for handling, shipping, installation and bracing of trusses. A seal on this drawing or cover page listing this drawing, indicates acceptance of professional engineering responsibility solely for the design shown. The suitability and use of this drawing for any structure is the responsibility of the Building Designer per ANSI/TPI 1 Sec.2.

For more information see these web sites: Alpine: alpineitw.com; TPI: tpinst.org; SBCA: sbccomponents.com; ICC: iccsafe.org; AWC: awc.org



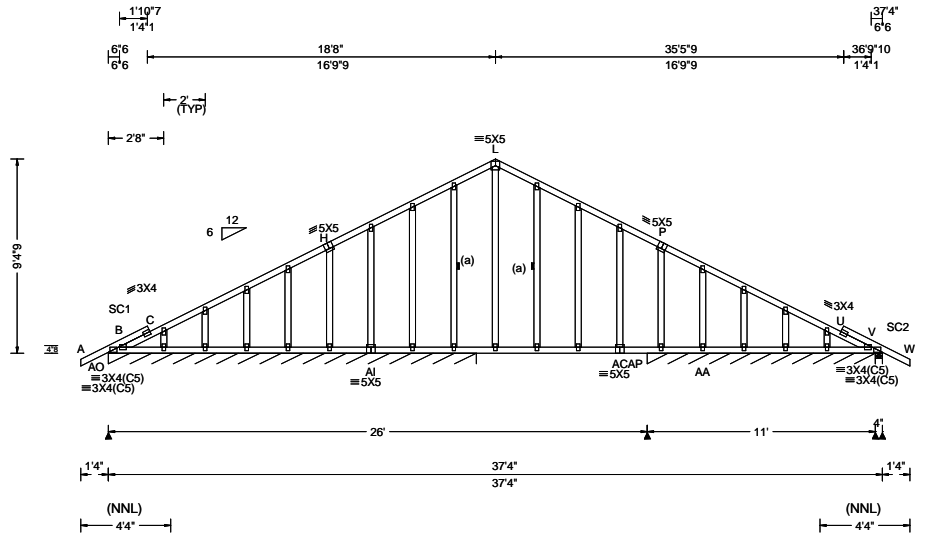

Loading Criteria (psf) TCLL: 20.00 TCDL: 10.00 BCLL: 0.00 BCDL: 10.00 Des Ld: 40.00 NCBCLL: 10.00 Soffit: 2.00 Load Duration: 1.25 Spacing: 24.0 "	Wind Criteria Wind Std: ASCE 7-10 Speed: 130 mph Enclosure: Closed Risk Category: II EXP: C Kzt: NA Mean Height: 15.00 ft TCDL: 5.0 psf BCDL: 5.0 psf MWFRS Parallel Dist: 0 to h/2 C&C Dist a: 3.73 ft Loc. from endwall: Any GCp: 0.18 Wind Duration: 1.60	Snow Criteria (Pg,Pf in PSF) Pg: NA Ct: NA CAT: NA Pf: NA Ce: NA Lu: NA Cs: NA Snow Duration: NA Building Code: FBC 2017 RES TPI Std: 2014 Rep Fac: Yes FT/RT:20(0)/10(0) Plate Type(s): WAVE	Defl/CSI Criteria PP Deflection in loc L/defl L/# VERT(LL): 0.118 AD 904 240 VERT(CL): 0.241 AD 444 180 HORZ(LL): -0.048 N - - HORZ(TL): 0.098 N - - Creep Factor: 2.0 Max TC CSI: 0.400 Max BC CSI: 0.523 Max Web CSI: 0.184 VIEW Ver: 21.01.01A.0521.20	▲ Maximum Reactions (lbs), or *=PLF Gravity Non-Gravity Loc R+ / R- / Rh / Rw / U / RL AO*101 - / - / - /60 - /13 AP*99 - / - / - /70 /24 - V 376 - / - /252 /3 - AA - /123 Wind reactions based on MWFRS AO Brg Wid = 212 Min Req = - AP Brg Wid = 132 Min Req = - V Brg Wid = 4.0 Min Req = 1.5 Bearings AO, AP, & V are a rigid surface. Members not listed have forces less than 375# Maximum Top Chord Forces Per Ply (lbs) Chords Tens.Comp. Chords Tens. Comp. B - C 305 -382 P - U 78 -377 C - H 267 -378 U - V 71 -381 L - P 223 -418 Maximum Bot Chord Forces Per Ply (lbs) Chords Tens.Comp. AI-AC 676 -126
--	--	---	--	---

Lumber
Top chord: 2x4 SP #2;
Bot chord: 2x4 SP #2;
Webs: 2x4 SP #3;
Stack Chord: SC1 2x4 SP #2;
Stack Chord: SC2 2x4 SP #2;

Bracing
(a) Continuous lateral restraint equally spaced on member.

Plating Notes
All plates are 2X4 except as noted.

Loading
Gable end supports 8" max rake overhang. Top chord must not be cut or notched.

Wind
Wind loads based on MWFRS with additional C&C member design.
Uplifts based on an elevation at or above 1000 ft.

Additional Notes
See DWGS A14015ENC101014 & GBLLETIN0118 for gable wind bracing and other requirements.
Stacked top chord must NOT be notched or cut in area (NNL). Dropped top chord braced at 24" oc intervals. Attach stacked top chord (SC) to dropped top chord in notchable area using 3x4 tie-plates 24" oc. Center plate on stacked/dropped chord interface, plate length perpendicular to chord length. Splice top chord in notchable area using 3x6.
The overall height of this truss excluding overhang is 9-4-9.

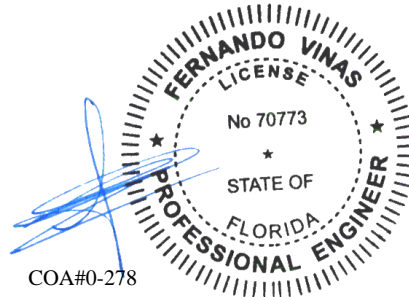

02/28/2022

****WARNING** READ AND FOLLOW ALL NOTES ON THIS DRAWING!**
****IMPORTANT** FURNISH THIS DRAWING TO ALL CONTRACTORS INCLUDING THE INSTALLERS**
Trusses require extreme care in fabricating, handling, shipping, installing and bracing. Refer to and follow the latest edition of BCSI (Building Component Safety Information, by TPI and SBCA) for safety practices prior to performing these functions. Installers shall provide temporary bracing per BCSI. Unless noted otherwise, top chord shall have properly attached structural sheathing and bottom chord shall have a properly attached rigid ceiling. Locations shown for permanent lateral restraint of webs shall have bracing installed per BCSI sections B3, B7, or B10, as applicable. Apply plates to each face of truss and position as shown above and on the Joint Details, unless noted otherwise. Refer to drawings 160A-2 for standard plate positions. Refer to job's General Notes page for additional information.
Alpine, a division of ITW Building Components Group Inc. shall not be responsible for any deviation from this drawing, any failure to build the truss in conformance with ANSI/TPI 1, or for handling, shipping, installation and bracing of trusses. A seal on this drawing or cover page listing this drawing, indicates acceptance of professional engineering responsibility solely for the design shown. The suitability and use of this drawing for any structure is the responsibility of the Building Designer per ANSI/TPI 1 Sec.2.
For more information see these web sites: Alpine: alpineitw.com; TPI: tpinst.org; SBCA: sbccomponents.com; ICC: iccsafe.org; AWC: awc.org



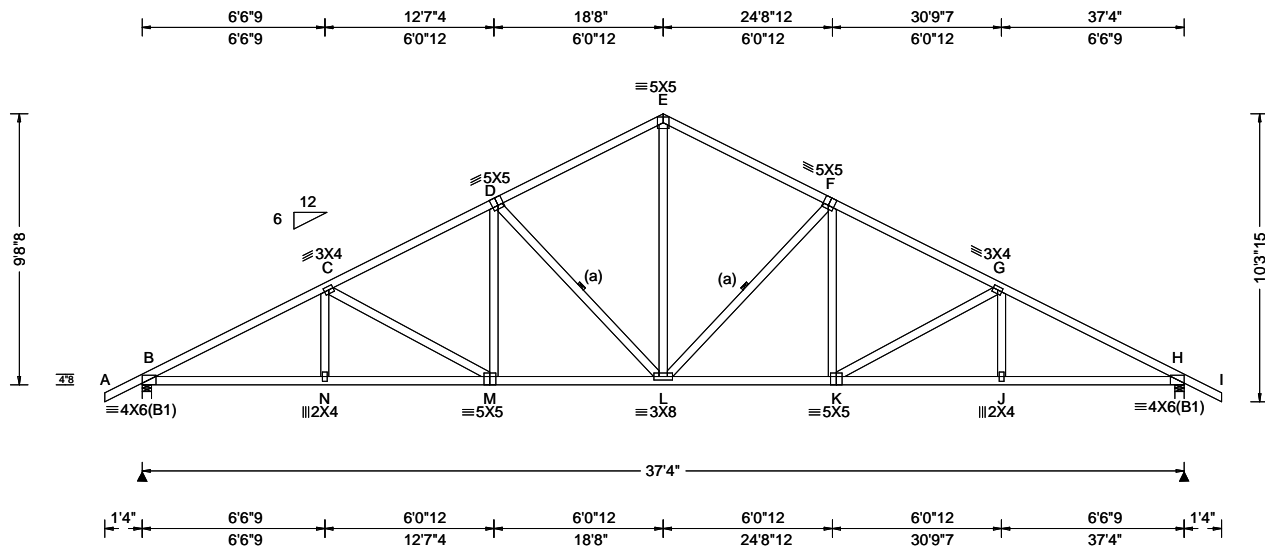

Loading Criteria (psf) TCLL: 20.00 TCDL: 10.00 BCLL: 0.00 BCDL: 10.00 Des Ld: 40.00 NCBCLL: 10.00 Soffit: 2.00 Load Duration: 1.25 Spacing: 24.0 "	Wind Criteria Wind Std: ASCE 7-10 Speed: 130 mph Enclosure: Closed Risk Category: II EXP: C Kzt: NA Mean Height: 15.00 ft TCDL: 5.0 psf BCDL: 5.0 psf MWFRS Parallel Dist: 0 to h/2 C&C Dist a: 3.73 ft Loc. from endwall: Any GCpi: 0.18 Wind Duration: 1.60	Snow Criteria (Pg,Pf in PSF) Pg: NA Ct: NA CAT: NA Pf: NA Ce: NA Lu: NA Cs: NA Snow Duration: NA Building Code: FBC 2017 RES TPI Std: 2014 Rep Fac: Yes FT/RT:20(0)/10(0) Plate Type(s): WAVE	Defl/CSI Criteria PP Deflection in loc L/defl L/# VERT(LL): 0.182 L 999 240 VERT(CL): 0.351 L 999 180 HORZ(LL): 0.077 J - - HORZ(TL): 0.148 J - - Creep Factor: 2.0 Max TC CSI: 0.523 Max BC CSI: 0.850 Max Web CSI: 0.906 VIEW Ver: 19.02.02B.0122.15	▲ Maximum Reactions (lbs) Gravity Non-Gravity Loc R+ / R- / Rh / Rw / U / RL B 1718 /- /- /978 /286 /283 H 1718 /- /- /978 /286 /- Wind reactions based on MWFRS B Brg Width = 4.0 Min Req = 2.0 H Brg Width = 4.0 Min Req = 2.0 Bearings B & H are a rigid surface. Members not listed have forces less than 375# Maximum Top Chord Forces Per Ply (lbs) Chords Tens.Comp. Chords Tens. Comp. B - C 1192 -3016 E - F 948 -1938 C - D 1079 -2537 F - G 1079 -2537 D - E 948 -1938 G - H 1193 -3016 Maximum Bot Chord Forces Per Ply (lbs) Chords Tens.Comp. Chords Tens. Comp. B - N 2616 -893 L - K 2179 -677 N - M 2614 -894 K - J 2614 -906 M - L 2179 -664 J - H 2616 -905 Maximum Web Forces Per Ply (lbs) Webs Tens.Comp. Webs Tens. Comp. C - M 283 -485 L - F 403 -764 M - D 446 -125 F - K 446 -125 D - L 403 -764 K - G 284 -485 E - L 1290 -534
--	---	---	---	---

Lumber

Top chord: 2x4 SP #2;
Bot chord: 2x4 SP #2;
Webs: 2x4 SP #3;

Bracing

(a) Continuous lateral restraint equally spaced on member.

Loading

Truss passed check for 20 psf additional bottom chord live load in areas with 42"-high x 24"-wide clearance.

Wind

Wind loads based on MWFRS with additional C&C member design.
Uplifts based on an elevation at or above 1000 ft.

Additional Notes

The overall height of this truss excluding overhang is 9-8-8.

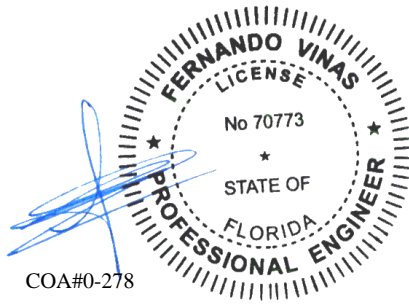

02/28/2022

****WARNING** READ AND FOLLOW ALL NOTES ON THIS DRAWING!**
****IMPORTANT** FURNISH THIS DRAWING TO ALL CONTRACTORS INCLUDING THE INSTALLERS**
Trusses require extreme care in fabricating, handling, shipping, installing and bracing. Refer to and follow the latest edition of BCSI (Building Component Safety Information, by TPI and SBCA) for safety practices prior to performing these functions. Installers shall provide temporary bracing per BCSI. Unless noted otherwise, top chord shall have properly attached structural sheathing and bottom chord shall have a properly attached rigid ceiling. Locations shown for permanent lateral restraint of webs shall have bracing installed per BCSI sections B3, B7, or B10, as applicable. Apply plates to each face of truss and position as shown above and on the Joint Details, unless noted otherwise. Refer to drawings 160A-Z for standard plate positions. Refer to job's General Notes page for additional information.
Alpine, a division of ITW Building Components Group Inc. shall not be responsible for any deviation from this drawing, any failure to build the truss in conformance with ANSI/TPI 1, or for handling, shipping, installation and bracing of trusses. A seal on this drawing or cover page listing this drawing, indicates acceptance of professional engineering responsibility solely for the design shown. The suitability and use of this drawing for any structure is the responsibility of the Building Designer per ANSI/TPI 1 Sec.2.
For more information see these web sites: Alpine: www.alpineitw.com; TPI: www.tpinst.org; SBCA: www.sbcindustry.com; ICC: www.iccsafe.org



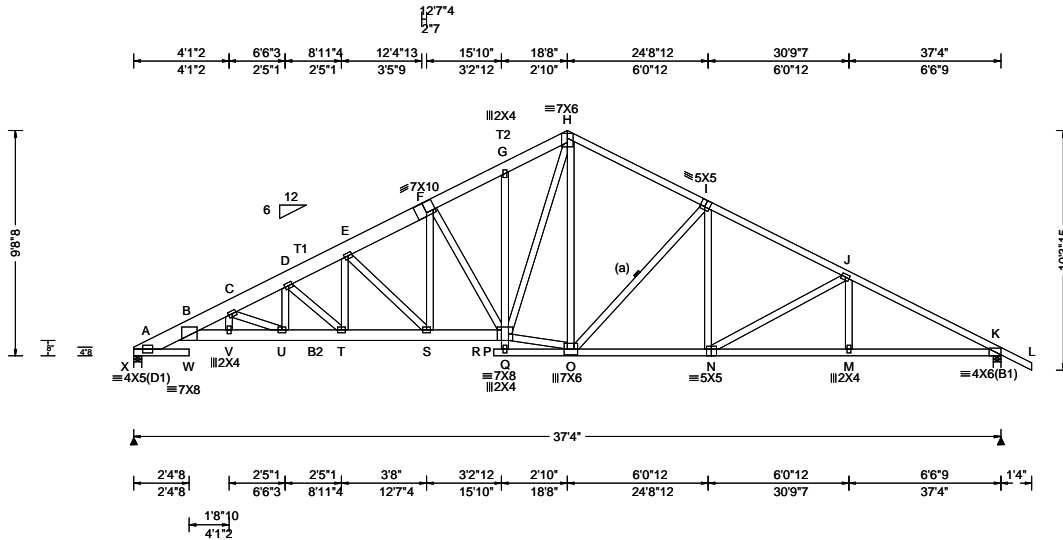

Loading Criteria (psf)	Wind Criteria	Snow Criteria (Pg,Pf in PSF)	Defl/CSI Criteria	▲ Maximum Reactions (lbs)
TCLL: 20.00 TCDL: 10.00 BCLL: 0.00 BCDL: 10.00 Des Ld: 40.00 NCBCLL: 10.00 Soffit: 2.00 Load Duration: 1.25 Spacing: 24.0 "	Wind Std: ASCE 7-10 Speed: 130 mph Enclosure: Closed Risk Category: II EXP: C Kzt: NA Mean Height: 15.00 ft TCDL: 5.0 psf BCDL: 5.0 psf MWFRS Parallel Dist: 0 to h/2 C&C Dist a: 3.73 ft Loc. from endwall: not in 4.50 ft GCpi: 0.18 Wind Duration: 1.60	Pg: NA Ct: NA CAT: NA Pf: NA Ce: NA Lu: NA Cs: NA Snow Duration: NA Building Code: FBC 2017 RES TPI Std: 2014 Rep Fac: Yes FT/RT:20(0)/10(0) Plate Type(s): WAVE	PP Deflection in loc L/defl L/# VERT(LL): 0.213 S 999 240 VERT(CL): 0.424 S 999 180 HORZ(LL): 0.131 M - - - HORZ(TL): 0.262 M - - - Creep Factor: 2.0 Max TC CSI: 0.632 Max BC CSI: 0.826 Max Web CSI: 0.619 VIEW Ver: 19.02.02B.0122.15	Gravity Loc R+ / R- / Rh / Rw / U / RL Non-Gravity X 1568 - / - / 902 / 262 / 270 K 1684 - / - / 977 / 286 - / - Wind reactions based on MWFRS X Brg Width = 4.0 Min Req = 1.9 K Brg Width = 4.0 Min Req = 2.0 Bearings X & K are a rigid surface. Members not listed have forces less than 375# Maximum Top Chord Forces Per Ply (lbs) Chords Tens.Comp. Chords Tens. Comp.

Lumber
Top chord: 2x4 SP #2; T1 2x8 SP 2400f-2.0E;
T2 2x6 SP 2400f-2.0E;
Bot chord: 2x4 SP #2; B2 2x6 SP 2400f-2.0E;
Webs: 2x4 SP #3;

Bracing
(a) Continuous lateral restraint equally spaced on member.

Plating Notes
All plates are 3X4 except as noted.

Loading
Truss passed check for 20 psf additional bottom chord live load in areas with 42"-high x 24"-wide clearance.

Wind
Wind loads based on MWFRS with additional C&C member design.
Uplifts based on an elevation at or above 1000 ft.

Additional Notes
The overall height of this truss excluding overhang is 9'-8".

Maximum Bot Chord Forces Per Ply (lbs)

Chords	Tens.Comp.	Chords	Tens. Comp.
B - V	4171 -833	S - P	2393 -366
V - U	4125 -823	O - N	2115 -322
U - T	3375 -625	N - M	2551 -451
T - S	2863 -492	M - K	2553 -451

Maximum Web Forces Per Ply (lbs)

Webs	Tens.Comp.	Webs	Tens. Comp.
V - C	152 -670	F - P	193 -686
C - U	217 -811	P - H	1338 -307
U - D	483 -107	P - O	1624 -178
D - T	180 -691	O - I	213 -753
T - E	557 -119	I - N	448 -56
E - S	186 -696	N - J	149 -486
F - S	482 -105		

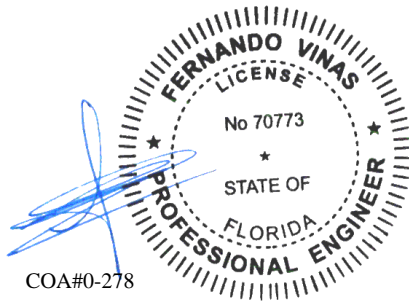

02/28/2022

****WARNING** READ AND FOLLOW ALL NOTES ON THIS DRAWING!**
****IMPORTANT** FURNISH THIS DRAWING TO ALL CONTRACTORS INCLUDING THE INSTALLERS**
Trusses require extreme care in fabricating, handling, shipping, installing and bracing. Refer to and follow the latest edition of BCSI (Building Component Safety Information, by TPI and SBCA) for safety practices prior to performing these functions. Installers shall provide temporary bracing per BCSI. Unless noted otherwise, top chord shall have properly attached structural sheathing and bottom chord shall have a properly attached rigid ceiling. Locations shown for permanent lateral restraint of webs shall have bracing installed per BCSI sections B3, B7, or B10, as applicable. Apply plates to each face of truss and position as shown above and on the Joint Details, unless noted otherwise. Refer to drawings 160A-Z for standard plate positions. Refer to job's General Notes page for additional information.
Alpine, a division of ITW Building Components Group Inc. shall not be responsible for any deviation from this drawing, any failure to build the truss in conformance with ANSI/TPI 1, or for handling, shipping, installation and bracing of trusses. A seal on this drawing or cover page listing this drawing, indicates acceptance of professional engineering responsibility solely for the design shown. The suitability and use of this drawing for any structure is the responsibility of the Building Designer per ANSI/TPI 1 Sec.2.
For more information see these web sites: Alpine: www.alpineitw.com; TPI: www.tpinst.org; SBCA: www.sbcindustry.com; ICC: www.iccsafe.org



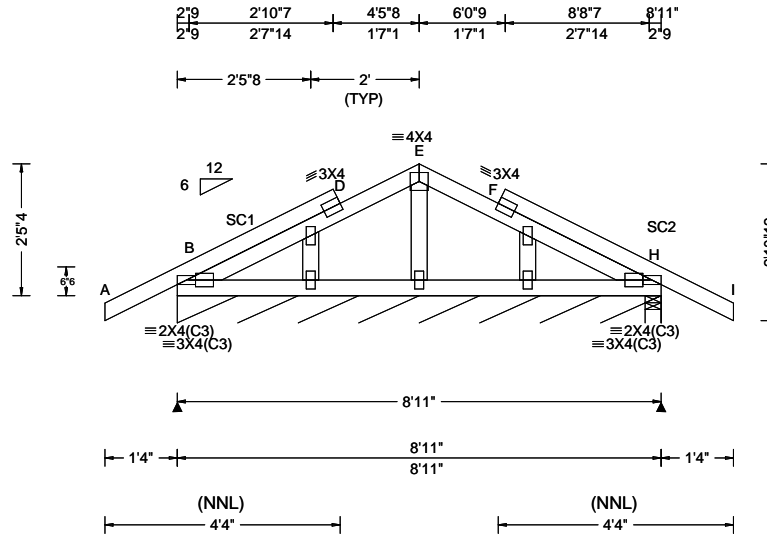

Loading Criteria (psf)	Wind Criteria	Snow Criteria (Pg,Pf in PSF)	Defl/CSI Criteria	▲ Maximum Reactions (lbs), or *=PLF
TCLL: 20.00 TCDL: 10.00 BCLL: 0.00 BCDL: 10.00 Des Ld: 40.00 NCBCLL: 10.00 Soffit: 2.00 Load Duration: 1.25 Spacing: 24.0 "	Wind Std: ASCE 7-10 Speed: 130 mph Enclosure: Closed Risk Category: II EXP: C Kzt: NA Mean Height: 15.00 ft TCDL: 5.0 psf BCDL: 5.0 psf MWFRS Parallel Dist: 0 to h/2 C&C Dist a: 3.00 ft Loc. from endwall: Any GCpi: 0.18 Wind Duration: 1.60	Pg: NA Ct: NA CAT: NA Pf: NA Ce: NA Lu: NA Cs: NA Snow Duration: NA Building Code: FBC 2017 RES TPI Std: 2014 Rep Fac: Yes FT/RT:20(0)/10(0) Plate Type(s): WAVE	PP Deflection in loc L/defl L/# VERT(LL): 0.002 F 999 240 VERT(CL): 0.005 F 999 180 HORZ(LL): -0.001 F - - HORZ(TL): 0.002 F - - Creep Factor: 2.0 Max TC CSI: 0.207 Max BC CSI: 0.063 Max Web CSI: 0.032 VIEW Ver: 21.01.01A.0521.20	Gravity Non-Gravity Loc R+ / R- / Rh / Rw / U / RL B* 78 /- /- /50 /3 /8 H 216 /- /- /165 /48 /- Wind reactions based on MWFRS B Brg Wid = 106 Min Req = - H Brg Wid = 3.5 Min Req = 1.5 Bearings B & H Fcperp = 565psi. Members not listed have forces less than 375#

Lumber
 Top chord: 2x4 SP #2;
 Bot chord: 2x4 SP #2;
 Webs: 2x4 SP #3;
 Stack Chord: SC1 2x4 SP #2;
 Stack Chord: SC2 2x4 SP #2;

Plating Notes
 All plates are 2X4 except as noted.

Wind
 Wind loads based on MWFRS with additional C&C member design.
 Uplifts based on an elevation at or above 1000 ft.

Additional Notes
 See DWGS A14015ENC101014 & GBLLETIN0118 for gable wind bracing and other requirements.
 Stacked top chord must NOT be notched or cut in area (NNL). Dropped top chord braced at 24" oc intervals. Attach stacked top chord (SC) to dropped top chord in notchable area using 3x4 tie-plates 24" oc. Center plate on stacked/dropped chord interface, plate length perpendicular to chord length. Splice top chord in notchable area using 3x6.
 The overall height of this truss excluding overhang is 3-5-4.

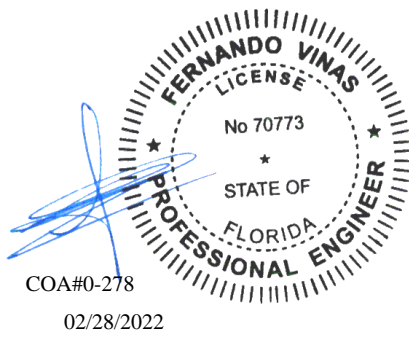

****WARNING** READ AND FOLLOW ALL NOTES ON THIS DRAWING!**
****IMPORTANT** FURNISH THIS DRAWING TO ALL CONTRACTORS INCLUDING THE INSTALLERS**
 Trusses require extreme care in fabricating, handling, shipping, installing and bracing. Refer to and follow the latest edition of BCSI (Building Component Safety Information, by TPI and SBCA) for safety practices prior to performing these functions. Installers shall provide temporary bracing per BCSI. Unless noted otherwise, top chord shall have properly attached structural sheathing and bottom chord shall have a properly attached rigid ceiling. Locations shown for permanent lateral restraint of webs shall have bracing installed per BCSI sections B3, B7, or B10, as applicable. Apply plates to each face of truss and position as shown above and on the Joint Details, unless noted otherwise. Refer to drawings 160A-Z for standard plate positions. Refer to job's General Notes page for additional information.
 Alpine, a division of ITW Building Components Group Inc. shall not be responsible for any deviation from this drawing, any failure to build the truss in conformance with ANSI/TPI 1, or for handling, shipping, installation and bracing of trusses. A seal on this drawing or cover page listing this drawing, indicates acceptance of professional engineering responsibility solely for the design shown. The suitability and use of this drawing for any structure is the responsibility of the Building Designer per ANSI/TPI 1 Sec.2.
 For more information see these web sites: Alpine: alpineitw.com; TPI: tpinst.org; SBCA: sbccomponents.com; ICC: iccsafe.org; AWC: awc.org



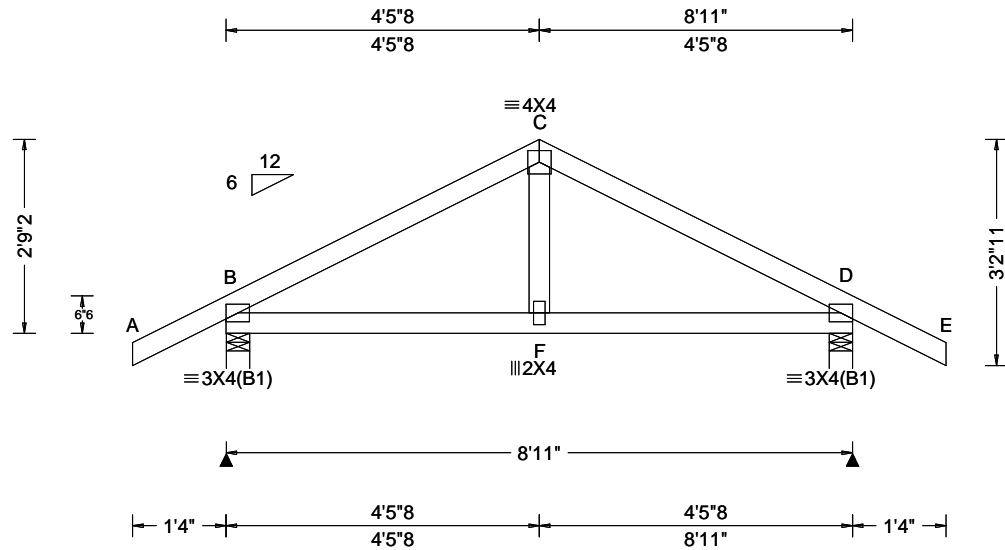

Loading Criteria (psf) TCCL: 20.00 TCDL: 10.00 BCLL: 0.00 BCDL: 10.00 Des Ld: 40.00 NCBCLL: 10.00 Soffit: 2.00 Load Duration: 1.25 Spacing: 24.0 "	Wind Criteria Wind Std: ASCE 7-10 Speed: 130 mph Enclosure: Closed Risk Category: II EXP: C Kzt: NA Mean Height: 15.00 ft TCDL: 5.0 psf BCDL: 5.0 psf MWFRS Parallel Dist: 0 to h/2 C&C Dist a: 3.00 ft Loc. from endwall: Any GCpi: 0.18 Wind Duration: 1.60	Snow Criteria (Pg,Pf in PSF) Pg: NA Ct: NA CAT: NA Pf: NA Ce: NA Lu: NA Cs: NA Snow Duration: NA Building Code: FBC 2017 RES TPI Std: 2014 Rep Fac: Yes FT/RT:20(0)/10(0) Plate Type(s): WAVE	Defl/CSI Criteria PP Deflection in loc L/def L/# VERT(LL): 0.006 F 999 240 VERT(CL): 0.012 F 999 180 HORZ(LL): 0.003 D - - HORZ(TL): 0.006 D - - Creep Factor: 2.0 Max TC CSI: 0.211 Max BC CSI: 0.190 Max Web CSI: 0.071 VIEW Ver: 21.01.01A.0521.20	▲ Maximum Reactions (lbs) <table border="1"> <thead> <tr> <th rowspan="2">Loc</th> <th colspan="3">Gravity</th> <th colspan="3">Non-Gravity</th> </tr> <tr> <th>R+</th> <th>/R-</th> <th>/Rh</th> <th>/Rw</th> <th>/U</th> <th>/RL</th> </tr> </thead> <tbody> <tr> <td>B</td> <td>430</td> <td>-</td> <td>-</td> <td>/268</td> <td>/80</td> <td>/83</td> </tr> <tr> <td>D</td> <td>438</td> <td>-</td> <td>-</td> <td>/269</td> <td>/79</td> <td>-</td> </tr> </tbody> </table>	Loc	Gravity			Non-Gravity			R+	/R-	/Rh	/Rw	/U	/RL	B	430	-	-	/268	/80	/83	D	438	-	-	/269	/79	-
				Loc		Gravity			Non-Gravity																						
R+	/R-	/Rh	/Rw		/U	/RL																									
B	430	-	-	/268	/80	/83																									
D	438	-	-	/269	/79	-																									
Wind reactions based on MWFRS B Brg Wid = 4.0 Min Req = 1.5 D Brg Wid = 4.0 Min Req = 1.5 Bearings B & D are a rigid surface. Members not listed have forces less than 375# Maximum Top Chord Forces Per Ply (lbs) <table border="1"> <thead> <tr> <th>Chords</th> <th>Tens.Comp.</th> <th>Chords</th> <th>Tens. Comp.</th> </tr> </thead> <tbody> <tr> <td>B - C</td> <td>332</td> <td>C - D</td> <td>332</td> </tr> </tbody> </table>				Chords	Tens.Comp.	Chords	Tens. Comp.	B - C	332	C - D	332																				
Chords	Tens.Comp.	Chords	Tens. Comp.																												
B - C	332	C - D	332																												

Lumber

Top chord: 2x4 SP #2;
 Bot chord: 2x4 SP #2;
 Webs: 2x4 SP #3;

Wind

Wind loads based on MWFRS with additional C&C member design.
 Uplifts based on an elevation at or above 1000 ft.

Additional Notes

The overall height of this truss excluding overhang is 2-9-2.

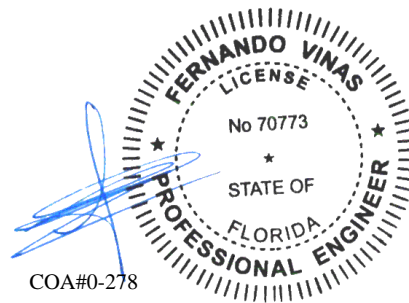

COA#0-278

02/28/2022

****WARNING** READ AND FOLLOW ALL NOTES ON THIS DRAWING!**
****IMPORTANT** FURNISH THIS DRAWING TO ALL CONTRACTORS INCLUDING THE INSTALLERS**
 Trusses require extreme care in fabricating, handling, shipping, installing and bracing. Refer to and follow the latest edition of BCSI (Building Component Safety Information, by TPI and SBCA) for safety practices prior to performing these functions. Installers shall provide temporary bracing per BCSI. Unless noted otherwise, top chord shall have properly attached structural sheathing and bottom chord shall have a properly attached rigid ceiling. Locations shown for permanent lateral restraint of webs shall have bracing installed per BCSI sections B3, B7, or B10, as applicable. Apply plates to each face of truss and position as shown above and on the Joint Details, unless noted otherwise. Refer to drawings 160A-Z for standard plate positions. Refer to job's General Notes page for additional information.
 Alpine, a division of ITW Building Components Group Inc. shall not be responsible for any deviation from this drawing, any failure to build the truss in conformance with ANSI/TPI 1, or for handling, shipping, installation and bracing of trusses. A seal on this drawing or cover page listing this drawing, indicates acceptance of professional engineering responsibility solely for the design shown. The suitability and use of this drawing for any structure is the responsibility of the Building Designer per ANSI/TPI 1 Sec.2.
 For more information see these web sites: Alpine: alpineitw.com; TPI: tpinst.org; SBCA: sbcacomponents.com; ICC: iccsafe.org; AWC: awc.org



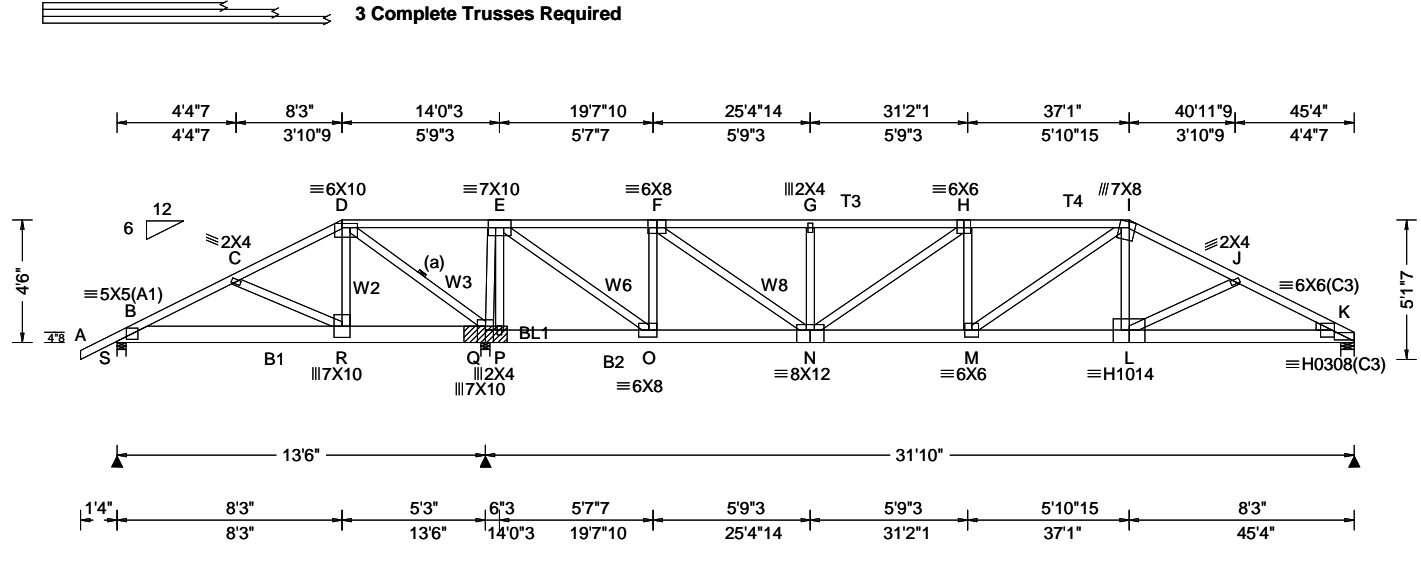

Loading Criteria (psf) TCCL: 20.00 TCCL: 10.00 BCLL: 0.00 BCDL: 10.00 Des Ld: 40.00 NCBCLL: 0.00 Soffit: 2.00 Load Duration: 1.25 Spacing: 24.0"	Wind Criteria Wind Std: ASCE 7-10 Speed: 130 mph Enclosure: Closed Risk Category: II EXP: C Kzt: NA Mean Height: 15.00 ft TCCL: 5.0 psf BCDL: 5.0 psf MWFRS Parallel Dist: 0 to h/2 C&C Dist a: 4.53 ft Loc. from endwall: not in 6.50 ft GCp: 0.18 Wind Duration: 1.60	Snow Criteria (Pg,Pf in PSF) Pg: NA Ct: NA CAT: NA Pf: NA Ce: NA Lu: NA Cs: NA Snow Duration: NA Building Code: FBC 2017 RES TPI Std: 2014 Rep Fac: Yes FT/RT:20(0)/10(0) Plate Type(s): WAVE, HS	Defl/CSI Criteria PP Deflection in loc L/defl L/# VERT(LL): 0.229 M 999 240 VERT(CL): 0.454 M 838 180 HORZ(LL): 0.029 K - - HORZ(TL): 0.058 K - - Creep Factor: 2.0 Max TC CSI: 0.667 Max BC CSI: 0.929 Max Web CSI: 0.992 VIEW Ver: 21.01.01A.0521.20	▲ Maximum Reactions (lbs) Gravity Loc R+ / R- / Rh / Rw / U / RL S 3140 /- /- /- /664 /- Q 18877 /- /- /- /2787 /- K 10443 /- /- /- /808 /- Wind reactions based on MWFRS S Brg Wid = 4.0 Min Req = 1.5 Q Brg Wid = 4.0 Min Req = - K Brg Wid = 6.0 Min Req = 2.9 Bearings S, Q, & K are a rigid surface. Members not listed have forces less than 375# Maximum Top Chord Forces Per Ply (lbs) Chords Tens.Comp. Chords Tens. Comp.
				B - C 177 -422 H - I 475 -5328 D - E 3522 -407 I - J 487 -5941 F - G 323 -2946 J - K 519 -6106 G - H 323 -2946 Maximum Bot Chord Forces Per Ply (lbs) Chords Tens.Comp. Chords Tens. Comp. B - R 419 -162 N - M 5218 -470 Q - P 364 -3222 M - L 5290 -430 P - O 372 -3278 L - K 5493 -460 Maximum Web Forces Per Ply (lbs) Webs Tens.Comp. Webs Tens. Comp. D - R 2745 -425 O - F 249 -2251 D - Q 649 -4502 F - N 3619 -349 Q - E 281 -1947 N - H 182 -2822 E - P 77 -596 H - M 1593 -60 E - O 3931 -497 I - L 2526 -141

Lumber
 Top chord: 2x4 SP M-31; T3,T4 2x4 SP #2;
 Bot chord: 2x6 SP 2400f-2.0E;
 B1 2x8 SP 2400f-2.0E; B2 2x6 SP #2;
 Webs: 2x4 SP #3; W2,W3,W6,W8 2x4 SP #2;
 Rt Wedge: 2x4 SP #3;

Bracing
 (a) Continuous lateral restraint equally spaced on member.

Nailnote
 Nail Schedule: 0.128"x3", min. nails
 Top Chord: 1 Row @ 12.00" o.c.
 Bot Chord: 2 Rows @ 4.50" o.c. (Each Row)
 Webs : 1 Row @ 4" o.c.
 Repeat nailing as each layer is applied. Use equal spacing between rows and stagger nails in each row to avoid splitting.

Wind
 Wind loads and reactions based on MWFRS.
 Uplifts based on an elevation at or above 1000 ft.

Bearing Block(s)
 Brg blocks: 0.128"x3", min. nails
 brg x-loc #blocks length/blk #nails/blk wall plate
 2 13.333' 2 19" 26 Rigid Surface
 Brg block to be same size and species as chord.
 Refer to drawing CNNAILSP1014 for more information.

Special Loads
 -----(Lumber Dur.Fac.=1.25 / Plate Dur.Fac.=1.25)
 TC: From 62 plf at -1.33 to 62 plf at 45.33
 BC: From 4 plf at -1.33 to 4 plf at 0.00
 BC: From 10 plf at 0.00 to 10 plf at 45.33
 BC: 1924 lb Conc. Load at 2.06, 4.06, 6.06, 8.06
 10.06
 BC: 1755 lb Conc. Load at 11.06, 13.06
 BC: 94 lb Conc. Load at 15.06
 BC: 136 lb Conc. Load at 17.06, 19.06
 BC: 144 lb Conc. Load at 21.06, 22.19, 24.19
 BC: 153 lb Conc. Load at 25.40, 27.40
 BC: 1922 lb Conc. Load at 29.40, 31.40
 BC: 1747 lb Conc. Load at 33.27
 BC: 1920 lb Conc. Load at 35.27, 37.27
 BC: 1917 lb Conc. Load at 39.27, 41.27
 BC: 1364 lb Conc. Load at 43.27

COA#0-278
02/28/2022

****WARNING** READ AND FOLLOW ALL NOTES ON THIS DRAWING!**
****IMPORTANT** FURNISH THIS DRAWING TO ALL CONTRACTORS INCLUDING THE INSTALLERS**
 Trusses require extreme care in fabricating, handling, shipping, installing and bracing. Refer to and follow the latest edition of BCSI (Building Component Safety Information, by TPI and SBCA) for safety practices prior to performing these functions. Installers shall provide temporary bracing per BCSI. Unless noted otherwise, top chord shall have properly attached structural sheathing and bottom chord shall have a properly attached rigid ceiling. Locations shown for permanent lateral restraint of webs shall have bracing installed per BCSI sections B3, B7, or B10, as applicable. Apply plates to each face of truss and position as shown above and on the Joint Details, unless noted otherwise. Refer to drawings 160A-Z for standard plate positions. Refer to job's General Notes page for additional information.
 Alpine, a division of ITW Building Components Group Inc. shall not be responsible for any deviation from this drawing, any failure to build the truss in conformance with ANSI/TPI 1, or for handling, shipping, installation and bracing of trusses. A seal on this drawing or cover page listing this drawing, indicates acceptance of professional engineering responsibility solely for the design shown. The suitability and use of this drawing for any structure is the responsibility of the Building Designer per ANSI/TPI 1 Sec.2.
 For more information see these web sites: Alpine: alpineitw.com; TPI: tpinst.org; SBCA: sbcacomponents.com; ICC: iccsafe.org; AWC: awc.org

6750 Forum Drive
Suite 305
Orlando FL, 32821

SEQN: 647488	COMN	Ply: 3	Job Number: 22-6970	Cust: R215 JRef: 1Xdd2150013 T29
FROM: CDM		Qty: 1	Jordan - Lancaster Model	DrwNo: 059.22.1342.00570
Page 2 of 2			Truss Label: G01	GA / FV 02/28/2022

Additional Notes

WARNING: Furnish a copy of this DWG to the installation contractor. Special care must be taken during handling, shipping and installation of trusses. See "WARNING" note below.

The overall height of this truss excluding overhang is 4-6-0.

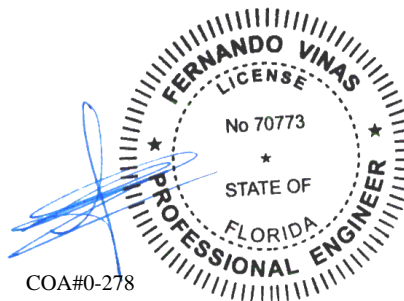

02/28/2022

****WARNING** READ AND FOLLOW ALL NOTES ON THIS DRAWING!**
****IMPORTANT** FURNISH THIS DRAWING TO ALL CONTRACTORS INCLUDING THE INSTALLERS**
 Trusses require extreme care in fabricating, handling, shipping, installing and bracing. Refer to and follow the latest edition of BCSI (Building Component Safety Information, by TPI and SBCA) for safety practices prior to performing these functions. Installers shall provide temporary bracing per BCSI. Unless noted otherwise, top chord shall have properly attached structural sheathing and bottom chord shall have a properly attached rigid ceiling. Locations shown for permanent lateral restraint of webs shall have bracing installed per BCSI sections B3, B7, or B10, as applicable. Apply plates to each face of truss and position as shown above and on the Joint Details, unless noted otherwise. Refer to drawings 160A-Z for standard plate positions. Refer to job's General Notes page for additional information.
 Alpine, a division of ITW Building Components Group Inc. shall not be responsible for any deviation from this drawing, any failure to build the truss in conformance with ANSI/TPI 1, or for handling, shipping, installation and bracing of trusses. A seal on this drawing or cover page listing this drawing, indicates acceptance of professional engineering responsibility solely for the design shown. The suitability and use of this drawing for any structure is the responsibility of the Building Designer per ANSI/TPI 1 Sec.2.
 For more information see these web sites: Alpine: alpineitw.com; TPI: tpinst.org; SBCA: sbcacomponents.com; ICC: iccsafe.org; AWC: awc.org



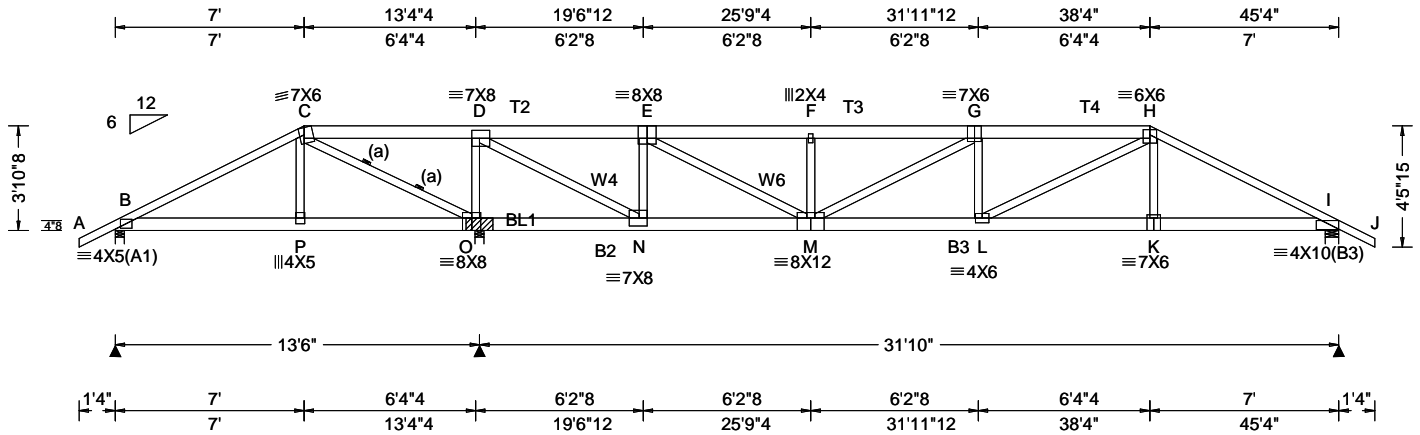

Loading Criteria (psf) TCLL: 20.00 TCDL: 10.00 BCLL: 0.00 BCDL: 10.00 Des Ld: 40.00 NCBCLL: 10.00 Soffit: 2.00 Load Duration: 1.25 Spacing: 24.0 "	Wind Criteria Wind Std: ASCE 7-10 Speed: 130 mph Enclosure: Closed Risk Category: II EXP: C Kzt: NA Mean Height: 15.00 ft TCDL: 5.0 psf BCDL: 5.0 psf MWFRS Parallel Dist: 0 to h/2 C&C Dist a: 4.53 ft Loc. from endwall: not in 6.50 ft GCp: 0.18 Wind Duration: 1.60	Snow Criteria (Pg,Pf in PSF) Pg: NA Ct: NA CAT: NA Pf: NA Ce: NA Lu: NA Cs: NA Snow Duration: NA Building Code: FBC 2017 RES TPI Std: 2014 Rep Fac: Varies by Ld Case FT/RT:20(0)/10(0) Plate Type(s): WAVE	Defl/CSI Criteria PP Deflection in loc L/defl L/# VERT(LL): 0.248 G 999 240 VERT(CL): 0.500 G 759 180 HORZ(LL): 0.028 I - - HORZ(TL): 0.057 I - - Creep Factor: 2.0 Max TC CSI: 0.844 Max BC CSI: 0.719 Max Web CSI: 0.928 VIEW Ver: 21.01.01A.0521.20	▲ Maximum Reactions (lbs) Gravity Loc R+ / R- / Rh / Rw / U / RL Non-Gravity B 249 /-142 /- /- /38 /- O 6051 /- /1 /- /1266 /0 I 2287 /- /- /- /470 /- Wind reactions based on MWFRS B Brg Wid = 4.0 Min Req = 1.5 O Brg Wid = 4.0 Min Req = - I Brg Wid = 6.0 Min Req = 2.7 Bearings B, O, & I are a rigid surface. Members not listed have forces less than 375# Maximum Top Chord Forces Per Ply (lbs) Chords Tens.Comp. Chords Tens. Comp.
--	---	---	---	--

Lumber
Top chord: 2x4 SP #2; T2 2x6 SP 2400f-2.0E; T3, T4 2x6 SP #2;
Bot chord: 2x6 SP #2; B2, B3 2x6 SP 2400f-2.0E;
Webs: 2x4 SP #3; W4 2x4 SP M-31; W6 2x4 SP #2;

Bearing Block(s)
Brg blocks: 0.128"x3", min. nails
brg x-loc #blocks length/blk #nails/blk wall plate
2 13.333' 1 12" 10 Rigid Surface
Brg block to be same size and species as chord.
Refer to drawing CNNAILSP1014 for more information.

Bracing
(a) Continuous lateral restraint equally spaced on member.

Additional Notes
WARNING: Furnish a copy of this DWG to the installation contractor. Special care must be taken during handling, shipping and installation of trusses. See "WARNING" note below.
The overall height of this truss excluding overhang is 3'-10.8."

Special Loads
----- (Lumber Dur.Fac.=1.25 / Plate Dur.Fac.=1.25)
TC: From 62 plf at -1.33 to 62 plf at 7.00
TC: From 31 plf at 7.00 to 31 plf at 38.33
TC: From 62 plf at 38.33 to 62 plf at 46.67
BC: From 4 plf at -1.33 to 4 plf at 0.00
BC: From 20 plf at 0.00 to 20 plf at 7.03
BC: From 10 plf at 7.03 to 10 plf at 36.27
BC: From 20 plf at 36.27 to 20 plf at 45.33
BC: From 4 plf at 45.33 to 4 plf at 46.67
TC: 189 lb Conc. Load at 7.06, 9.06, 11.06, 13.06
14.67, 16.27, 18.27, 20.27, 22.27, 24.27, 26.27, 28.27
30.27, 32.27, 34.27, 36.27, 38.27
BC: 556 lb Conc. Load at 7.03
BC: 129 lb Conc. Load at 9.06, 11.06, 13.06, 14.67
16.27, 18.27, 20.27, 22.27, 24.27, 26.27, 28.27, 30.27
32.27, 34.27, 36.27, 38.27

Wind
Wind loads and reactions based on MWFRS.
Uplifts based on an elevation at or above 1000 ft.

Maximum Bot Chord Forces Per Ply (lbs)

Chords	Tens.Comp.	Chords	Tens. Comp.
B - P	76 -553	M - L	5444 -1134
P - O	78 -591	L - K	3830 -774
O - N	1284 -6353	K - I	3846 -771
N - M	1585 -341		

Maximum Web Forces Per Ply (lbs)

Webs	Tens.Comp.	Webs	Tens. Comp.
P - C	912 -68	E - M	3513 -721
C - O	732 -3556	F - M	284 -742
O - D	902 -3603	M - G	189 -935
D - N	5243 -1072	G - L	229 -394
N - E	642 -2467	L - H	1808 -390

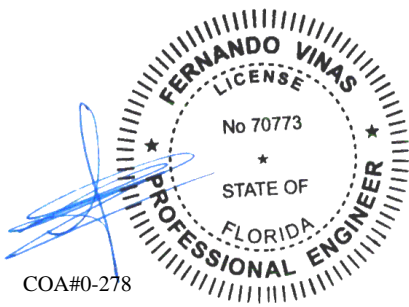

02/28/2022

****WARNING** READ AND FOLLOW ALL NOTES ON THIS DRAWING!**
****IMPORTANT** FURNISH THIS DRAWING TO ALL CONTRACTORS INCLUDING THE INSTALLERS**
Trusses require extreme care in fabricating, handling, shipping, installing and bracing. Refer to and follow the latest edition of BCSI (Building Component Safety Information, by TPI and SBCA) for safety practices prior to performing these functions. Installers shall provide temporary bracing per BCSI. Unless noted otherwise, top chord shall have properly attached structural sheathing and bottom chord shall have a properly attached rigid ceiling. Locations shown for permanent lateral restraint of webs shall have bracing installed per BCSI sections B3, B7, or B10, as applicable. Apply plates to each face of truss and position as shown above and on the Joint Details, unless noted otherwise. Refer to drawings 160A-Z for standard plate positions. Refer to job's General Notes page for additional information.
Alpine, a division of ITW Building Components Group Inc. shall not be responsible for any deviation from this drawing, any failure to build the truss in conformance with ANSI/TPI 1, or for handling, shipping, installation and bracing of trusses. A seal on this drawing or cover page listing this drawing, indicates acceptance of professional engineering responsibility solely for the design shown. The suitability and use of this drawing for any structure is the responsibility of the Building Designer per ANSI/TPI 1 Sec.2.
For more information see these web sites: Alpine: alpineitw.com; TPI: tpinst.org; SBCA: sbccomponents.com; ICC: iccsafe.org; AWC: awc.org



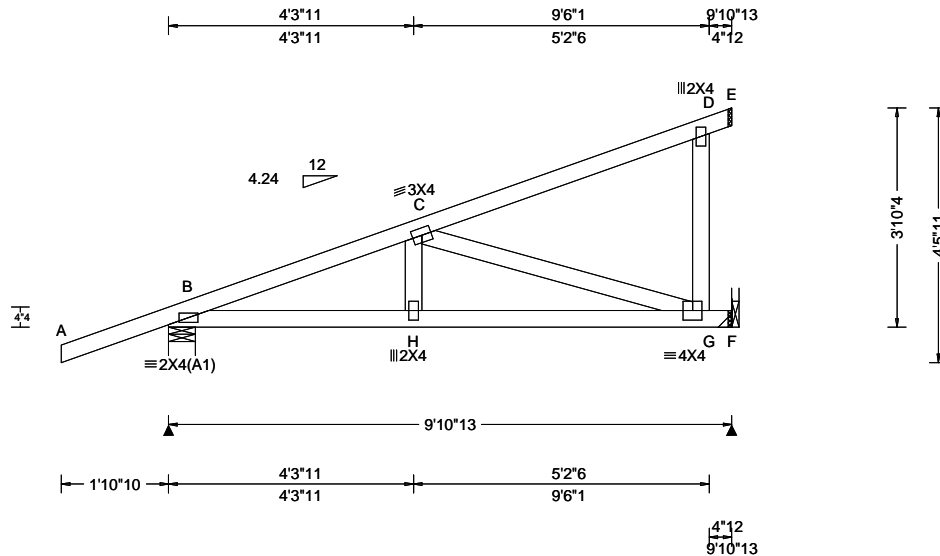

Loading Criteria (psf) TCLL: 20.00 TCDL: 10.00 BCLL: 0.00 BCDL: 10.00 Des Ld: 40.00 NCBCLL: 10.00 Soffit: 2.00 Load Duration: 1.25 Spacing: 24.0 "	Wind Criteria Wind Std: ASCE 7-10 Speed: 130 mph Enclosure: Closed Risk Category: II EXP: C Kzt: NA Mean Height: 15.00 ft TCDL: 5.0 psf BCDL: 5.0 psf MWFRS Parallel Dist: 0 to h/2 C&C Dist a: 3.00 ft Loc. from endwall: not in 4.50 ft GCp: 0.18 Wind Duration: 1.60	Snow Criteria (Pg,Pf in PSF) Pg: NA Ct: NA CAT: NA Pf: NA Ce: NA Lu: NA Cs: NA Snow Duration: NA Building Code: FBC 2017 RES TPI Std: 2014 Rep Fac: Varies by Ld Case FT/RT:20(0)/10(0) Plate Type(s): WAVE	Defl/CSI Criteria PP Deflection in loc L/defl L/# VERT(LL): 0.033 H 999 240 VERT(CL): 0.066 H 999 180 HORZ(LL): 0.008 C - - HORZ(TL): 0.015 C - - Creep Factor: 2.0 Max TC CSI: 0.768 Max BC CSI: 0.929 Max Web CSI: 0.428 VIEW Ver: 21.01.01A.0521.20	▲ Maximum Reactions (lbs) <table style="width:100%; border-collapse: collapse;"> <thead> <tr> <th rowspan="2">Loc</th> <th colspan="3">Gravity</th> <th colspan="3">Non-Gravity</th> </tr> <tr> <th>R+</th> <th>/R-</th> <th>/Rh</th> <th>/Rw</th> <th>/U</th> <th>/RL</th> </tr> </thead> <tbody> <tr> <td>B</td> <td>361</td> <td>-</td> <td>-</td> <td>-</td> <td>167</td> <td>-</td> </tr> <tr> <td>F</td> <td>427</td> <td>-</td> <td>-</td> <td>-</td> <td>95</td> <td>-</td> </tr> </tbody> </table> <p>Wind reactions based on MWFRS B Brg Wid = 5.7 Min Req = 1.5 F Brg Wid = - Bearing B is a rigid surface. Members not listed have forces less than 375#</p> Maximum Top Chord Forces Per Ply (lbs) <table style="width:100%; border-collapse: collapse;"> <thead> <tr> <th>Chords</th> <th>Tens.Comp.</th> </tr> </thead> <tbody> <tr> <td>B - C</td> <td>246 -832</td> </tr> </tbody> </table>	Loc	Gravity			Non-Gravity			R+	/R-	/Rh	/Rw	/U	/RL	B	361	-	-	-	167	-	F	427	-	-	-	95	-	Chords	Tens.Comp.	B - C	246 -832
Loc	Gravity			Non-Gravity																															
	R+	/R-	/Rh	/Rw	/U	/RL																													
B	361	-	-	-	167	-																													
F	427	-	-	-	95	-																													
Chords	Tens.Comp.																																		
B - C	246 -832																																		

Lumber

Top chord: 2x4 SP #2;
 Bot chord: 2x4 SP #2;
 Webs: 2x4 SP #3;

Special Loads

----(Lumber Dur.Fac.=1.25 / Plate Dur.Fac.=1.25)
 TC: From -0 plf at -1.89 to 61 plf at 0.00
 TC: From 2 plf at 0.00 to 2 plf at 9.90
 BC: From 0 plf at -1.89 to 4 plf at 0.00
 BC: From 2 plf at 0.00 to 2 plf at 9.90
 TC: -30 lb Conc. Load at 1.48
 TC: 132 lb Conc. Load at 4.31
 TC: 260 lb Conc. Load at 7.13
 BC: 14 lb Conc. Load at 1.48
 BC: 101 lb Conc. Load at 4.31
 BC: 181 lb Conc. Load at 7.13

Wind

Wind loads and reactions based on MWFRS.
 Uplifts based on an elevation at or above 1000 ft.

Additional Notes

The overall height of this truss excluding overhang is 3-10-4.

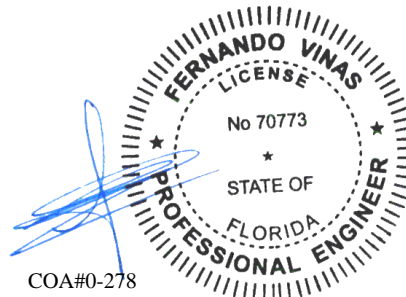

02/28/2022

****WARNING** READ AND FOLLOW ALL NOTES ON THIS DRAWING!**
****IMPORTANT** FURNISH THIS DRAWING TO ALL CONTRACTORS INCLUDING THE INSTALLERS**
 Trusses require extreme care in fabricating, handling, shipping, installing and bracing. Refer to and follow the latest edition of BCSI (Building Component Safety Information, by TPI and SBCA) for safety practices prior to performing these functions. Installers shall provide temporary bracing per BCSI. Unless noted otherwise, top chord shall have properly attached structural sheathing and bottom chord shall have a properly attached rigid ceiling. Locations shown for permanent lateral restraint of webs shall have bracing installed per BCSI sections B3, B7, or B10, as applicable. Apply plates to each face of truss and position as shown above and on the Joint Details, unless noted otherwise. Refer to drawings 160A-Z for standard plate positions. Refer to job's General Notes page for additional information.
 Alpine, a division of ITW Building Components Group Inc. shall not be responsible for any deviation from this drawing, any failure to build the truss in conformance with ANSI/TPI 1, or for handling, shipping, installation and bracing of trusses. A seal on this drawing or cover page listing this drawing, indicates acceptance of professional engineering responsibility solely for the design shown. The suitability and use of this drawing for any structure is the responsibility of the Building Designer per ANSI/TPI 1 Sec.2.
 For more information see these web sites: Alpine: alpineitw.com; TPI: tpinst.org; SBCA: sbccomponents.com; ICC: iccsafe.org; AWC: awc.org



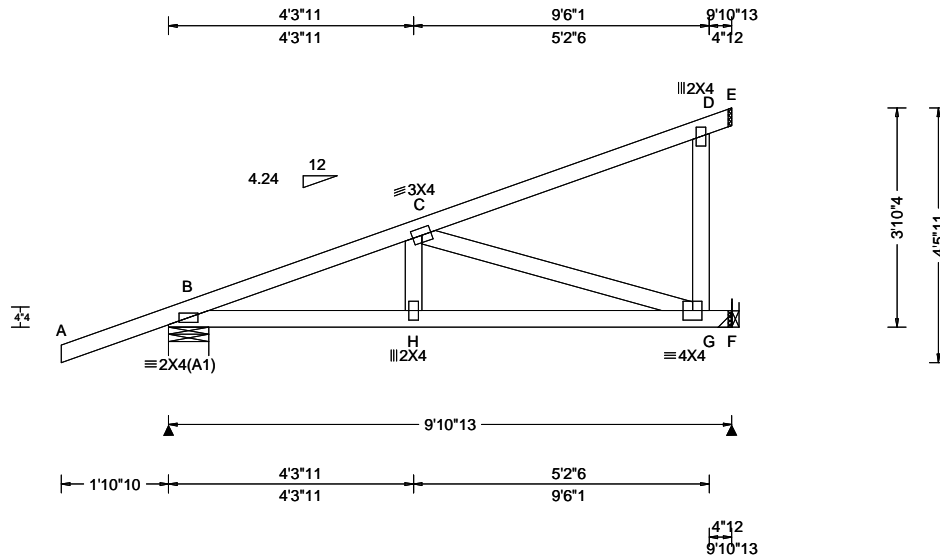

Loading Criteria (psf) TCLL: 20.00 TCDL: 10.00 BCLL: 0.00 BCDL: 10.00 Des Ld: 40.00 NCBCLL: 10.00 Soffit: 2.00 Load Duration: 1.25 Spacing: 24.0 "	Wind Criteria Wind Std: ASCE 7-10 Speed: 130 mph Enclosure: Closed Risk Category: II EXP: C Kzt: NA Mean Height: 15.00 ft TCCL: 5.0 psf BCDL: 5.0 psf MWFRS Parallel Dist: 0 to h/2 C&C Dist a: 3.00 ft Loc. from endwall: not in 4.50 ft GCp: 0.18 Wind Duration: 1.60	Snow Criteria (Pg,Pf in PSF) Pg: NA Ct: NA CAT: NA Pf: NA Ce: NA Lu: NA Cs: NA Snow Duration: NA Building Code: FBC 2017 RES TPI Std: 2014 Rep Fac: Varies by Ld Case FT/RT:20(0)/10(0) Plate Type(s): WAVE	Defl/CSI Criteria PP Deflection in loc L/def L/# VERT(LL): 0.033 H 999 240 VERT(CL): 0.066 H 999 180 HORZ(LL): 0.008 C - - HORZ(TL): 0.015 C - - Creep Factor: 2.0 Max TC CSI: 0.768 Max BC CSI: 0.929 Max Web CSI: 0.428 VIEW Ver: 21.01.01A.0521.20	▲ Maximum Reactions (lbs) <table style="width:100%; border-collapse: collapse;"> <thead> <tr> <th rowspan="2">Loc</th> <th colspan="3">Gravity</th> <th colspan="3">Non-Gravity</th> </tr> <tr> <th>R+</th> <th>/R-</th> <th>/Rh</th> <th>/Rw</th> <th>/U</th> <th>/RL</th> </tr> </thead> <tbody> <tr> <td>B</td> <td>361</td> <td>-</td> <td>-</td> <td>-</td> <td>167</td> <td>-</td> </tr> <tr> <td>F</td> <td>427</td> <td>-</td> <td>-</td> <td>-</td> <td>95</td> <td>-</td> </tr> </tbody> </table> <p>Wind reactions based on MWFRS B Brg Wid = 8.5 Min Req = 1.5 F Brg Wid = - Bearing B is a rigid surface. Members not listed have forces less than 375#</p> Maximum Top Chord Forces Per Ply (lbs) <table style="width:100%; border-collapse: collapse;"> <thead> <tr> <th>Chords</th> <th>Tens.Comp.</th> </tr> </thead> <tbody> <tr> <td>B - C</td> <td>246 -832</td> </tr> </tbody> </table>	Loc	Gravity			Non-Gravity			R+	/R-	/Rh	/Rw	/U	/RL	B	361	-	-	-	167	-	F	427	-	-	-	95	-	Chords	Tens.Comp.	B - C	246 -832
Loc	Gravity			Non-Gravity																															
	R+	/R-	/Rh	/Rw	/U	/RL																													
B	361	-	-	-	167	-																													
F	427	-	-	-	95	-																													
Chords	Tens.Comp.																																		
B - C	246 -832																																		

Lumber

Top chord: 2x4 SP #2;
 Bot chord: 2x4 SP #2;
 Webs: 2x4 SP #3;

Special Loads

----(Lumber Dur.Fac.=1.25 / Plate Dur.Fac.=1.25)
 TC: From -0 plf at -1.89 to 61 plf at 0.00
 TC: From 2 plf at 0.00 to 2 plf at 9.90
 BC: From 0 plf at -1.89 to 4 plf at 0.00
 BC: From 2 plf at 0.00 to 2 plf at 9.90
 TC: -30 lb Conc. Load at 1.48
 TC: 132 lb Conc. Load at 4.31
 TC: 260 lb Conc. Load at 7.13
 BC: 14 lb Conc. Load at 1.48
 BC: 101 lb Conc. Load at 4.31
 BC: 181 lb Conc. Load at 7.13

Wind

Wind loads and reactions based on MWFRS.
 Uplifts based on an elevation at or above 1000 ft.

Additional Notes

The overall height of this truss excluding overhang is 3-10-4.

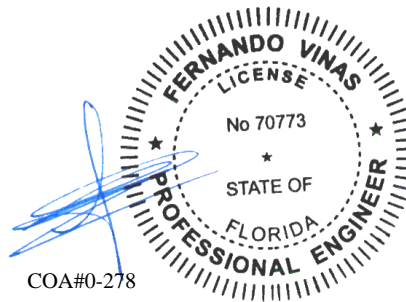

****WARNING** READ AND FOLLOW ALL NOTES ON THIS DRAWING!**
****IMPORTANT** FURNISH THIS DRAWING TO ALL CONTRACTORS INCLUDING THE INSTALLERS**
 Trusses require extreme care in fabricating, handling, shipping, installing and bracing. Refer to and follow the latest edition of BCSI (Building Component Safety Information, by TPI and SBCA) for safety practices prior to performing these functions. Installers shall provide temporary bracing per BCSI. Unless noted otherwise, top chord shall have properly attached structural sheathing and bottom chord shall have a properly attached rigid ceiling. Locations shown for permanent lateral restraint of webs shall have bracing installed per BCSI sections B3, B7, or B10, as applicable. Apply plates to each face of truss and position as shown above and on the Joint Details, unless noted otherwise. Refer to drawings 160A-Z for standard plate positions. Refer to job's General Notes page for additional information.
 Alpine, a division of ITW Building Components Group Inc. shall not be responsible for any deviation from this drawing, any failure to build the truss in conformance with ANSI/TPI 1, or for handling, shipping, installation and bracing of trusses. A seal on this drawing or cover page listing this drawing, indicates acceptance of professional engineering responsibility solely for the design shown. The suitability and use of this drawing for any structure is the responsibility of the Building Designer per ANSI/TPI 1 Sec.2.
 For more information see these web sites: Alpine: alpineitw.com; TPI: tpinst.org; SBCA: sbccomponents.com; ICC: iccsafe.org; AWC: awc.org



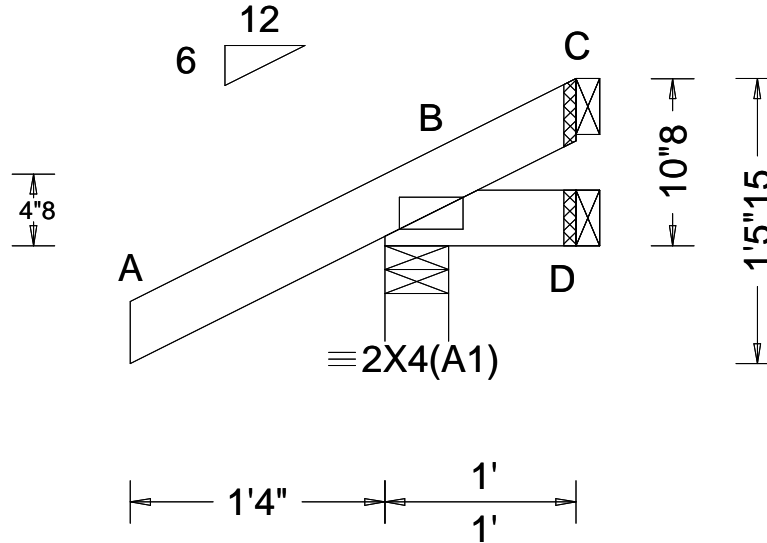

Loading Criteria (psf)	Wind Criteria	Snow Criteria (Pg,Pf in PSF)	Defl/CSI Criteria	▲ Maximum Reactions (lbs)						
				Gravity			Non-Gravity			
TCLL: 20.00	Wind Std: ASCE 7-10	Pg: NA Ct: NA CAT: NA	PP Deflection in loc L/defl L/#	Loc	R+	/R-	/Rh	/Rw	/U	/RL
TCDL: 10.00	Speed: 130 mph	Pf: NA Ce: NA	VERT(LL): NA	B	222	/-	/-	/175	/57	/32
BCLL: 0.00	Enclosure: Closed	Lu: NA Cs: NA	VERT(CL): NA	D	7	/-11	/-	/15	/12	/-
BCDL: 10.00	Risk Category: II	Snow Duration: NA	HORZ(LL): -0.000 B - -	C	-	/-40	/-	/25	/42	/-
Des Ld: 40.00	EXP: C Kzt: NA	Building Code:	HORZ(TL): 0.000 B - -	Wind reactions based on MWFRS						
NCBCLL: 10.00	Mean Height: 15.00 ft	FBC 2017 RES	Creep Factor: 2.0	B Brg Wid = 4.0 Min Req = 1.5						
Soffit: 2.00	TCDL: 5.0 psf	TPI Std: 2014	Max TC CSI: 0.199	D Brg Wid = 1.5						
Load Duration: 1.25	BCDL: 5.0 psf	Rep Fac: Yes	Max BC CSI: 0.029	C Brg Wid = 1.5						
Spacing: 24.0 "	MWFRS Parallel Dist: 0 to h/2	FT/RT:20(0)/10(0)	Max Web CSI: 0.000	Bearing B is a rigid surface.						
	C&C Dist a: 3.00 ft	Plate Type(s):	VIEW Ver: 21.01.01A.0521.20	Members not listed have forces less than 375#						
	Loc. from endwall: Any	WAVE								
	GCp1: 0.18									
	Wind Duration: 1.60									

Lumber

Top chord: 2x4 SP #2;
Bot chord: 2x4 SP #2;

Wind

Wind loads based on MWFRS with additional C&C member design.
Uplifts based on an elevation at or above 1000 ft.

Additional Notes

The overall height of this truss excluding overhang is 0-10-8.

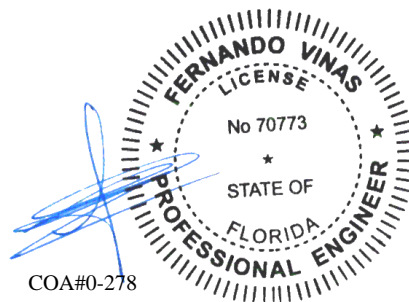

COA#0-278

02/28/2022

****WARNING** READ AND FOLLOW ALL NOTES ON THIS DRAWING!**
****IMPORTANT** FURNISH THIS DRAWING TO ALL CONTRACTORS INCLUDING THE INSTALLERS**

Trusses require extreme care in fabricating, handling, shipping, installing and bracing. Refer to and follow the latest edition of BCSI (Building Component Safety Information, by TPI and SBCA) for safety practices prior to performing these functions. Installers shall provide temporary bracing per BCSI. Unless noted otherwise, top chord shall have properly attached structural sheathing and bottom chord shall have a properly attached rigid ceiling. Locations shown for permanent lateral restraint of webs shall have bracing installed per BCSI sections B3, B7, or B10, as applicable. Apply plates to each face of truss and position as shown above and on the Joint Details, unless noted otherwise. Refer to drawings 160A-Z for standard plate positions. Refer to job's General Notes page for additional information.

Alpine, a division of ITW Building Components Group Inc. shall not be responsible for any deviation from this drawing, any failure to build the truss in conformance with ANSI/TPI 1, or for handling, shipping, installation and bracing of trusses. A seal on this drawing or cover page listing this drawing, indicates acceptance of professional engineering responsibility solely for the design shown. The suitability and use of this drawing for any structure is the responsibility of the Building Designer per ANSI/TPI 1 Sec.2.

For more information see these web sites: Alpine: alpineitw.com; TPI: tpinst.org; SBCA: sbcacomponents.com; ICC: iccsafe.org; AWC: awc.org



6750 Forum Drive
Suite 305
Orlando FL, 32821

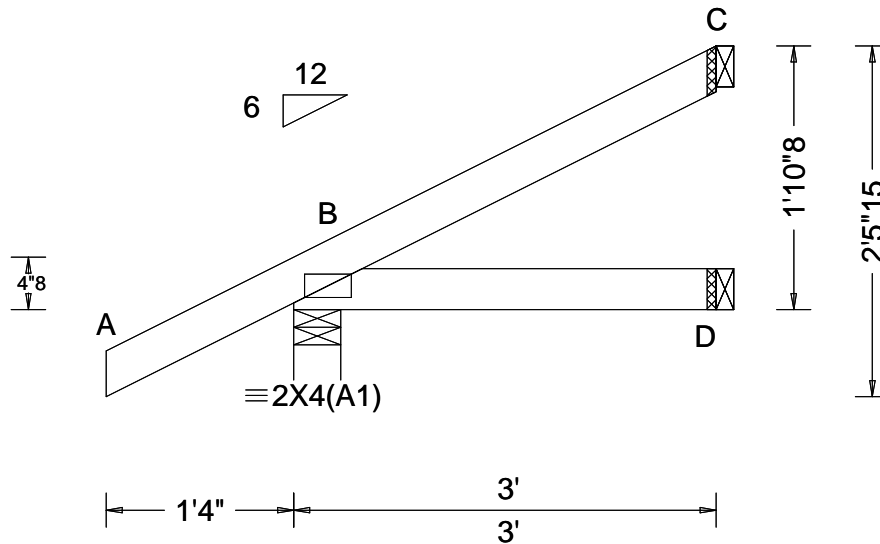

Loading Criteria (psf) TCCL: 20.00 TCCL: 10.00 BCLL: 0.00 BCDL: 10.00 Des Ld: 40.00 NCBCLL: 10.00 Soffit: 2.00 Load Duration: 1.25 Spacing: 24.0 "	Wind Criteria Wind Std: ASCE 7-10 Speed: 130 mph Enclosure: Closed Risk Category: II EXP: C Kzt: NA Mean Height: 15.00 ft TCCL: 5.0 psf BCDL: 5.0 psf MWFRS Parallel Dist: 0 to h/2 C&C Dist a: 3.00 ft Loc. from endwall: Any GCp: 0.18 Wind Duration: 1.60	Snow Criteria (Pg,Pf in PSF) Pg: NA Ct: NA CAT: NA Pf: NA Ce: NA Lu: NA Cs: NA Snow Duration: NA Building Code: FBC 2017 RES TPI Std: 2014 Rep Fac: Yes FT/RT:20(0)/10(0) Plate Type(s): WAVE	Defl/CSI Criteria PP Deflection in loc L/def L/# VERT(LL): NA VERT(CL): NA HORZ(LL): 0.001 B - - HORZ(TL): 0.001 B - - Creep Factor: 2.0 Max TC CSI: 0.205 Max BC CSI: 0.067 Max Web CSI: 0.000 VIEW Ver: 21.01.01A.0521.20	▲ Maximum Reactions (lbs) <table border="1"> <thead> <tr> <th rowspan="2">Loc</th> <th colspan="3">Gravity</th> <th colspan="3">Non-Gravity</th> </tr> <tr> <th>R+</th> <th>/R-</th> <th>/Rh</th> <th>/Rw</th> <th>/U</th> <th>/RL</th> </tr> </thead> <tbody> <tr> <td>B</td> <td>244</td> <td>/-</td> <td>/-</td> <td>/177</td> <td>/39</td> <td>/61</td> </tr> <tr> <td>D</td> <td>50</td> <td>/-</td> <td>/-</td> <td>/38</td> <td>/-</td> <td>/-</td> </tr> <tr> <td>C</td> <td>66</td> <td>/-</td> <td>/-</td> <td>/29</td> <td>/26</td> <td>/-</td> </tr> </tbody> </table> Wind reactions based on MWFRS B Brg Wid = 4.0 Min Req = 1.5 D Brg Wid = 1.5 C Brg Wid = 1.5 Bearing B is a rigid surface. Members not listed have forces less than 375#	Loc	Gravity			Non-Gravity			R+	/R-	/Rh	/Rw	/U	/RL	B	244	/-	/-	/177	/39	/61	D	50	/-	/-	/38	/-	/-	C	66	/-	/-	/29	/26	/-
				Loc		Gravity			Non-Gravity																													
R+	/R-	/Rh	/Rw		/U	/RL																																
B	244	/-	/-	/177	/39	/61																																
D	50	/-	/-	/38	/-	/-																																
C	66	/-	/-	/29	/26	/-																																
Lumber Top chord: 2x4 SP #2; Bot chord: 2x4 SP #2; Wind Wind loads based on MWFRS with additional C&C member design. Uplifts based on an elevation at or above 1000 ft. Additional Notes The overall height of this truss excluding overhang is 1-10-8.																																						

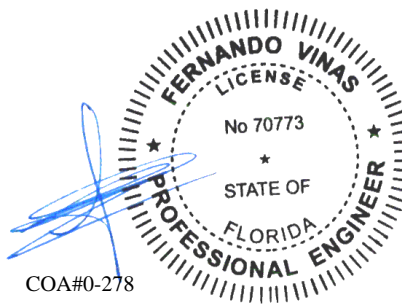

COA#0-278

02/28/2022

****WARNING** READ AND FOLLOW ALL NOTES ON THIS DRAWING!**
****IMPORTANT** FURNISH THIS DRAWING TO ALL CONTRACTORS INCLUDING THE INSTALLERS**
 Trusses require extreme care in fabricating, handling, shipping, installing and bracing. Refer to and follow the latest edition of BCSI (Building Component Safety Information, by TPI and SBCA) for safety practices prior to performing these functions. Installers shall provide temporary bracing per BCSI. Unless noted otherwise, top chord shall have properly attached structural sheathing and bottom chord shall have a properly attached rigid ceiling. Locations shown for permanent lateral restraint of webs shall have bracing installed per BCSI sections B3, B7, or B10, as applicable. Apply plates to each face of truss and position as shown above and on the Joint Details, unless noted otherwise. Refer to drawings 160A-Z for standard plate positions. Refer to job's General Notes page for additional information.
 Alpine, a division of ITW Building Components Group Inc. shall not be responsible for any deviation from this drawing, any failure to build the truss in conformance with ANSI/TPI 1, or for handling, shipping, installation and bracing of trusses. A seal on this drawing or cover page listing this drawing, indicates acceptance of professional engineering responsibility solely for the design shown. The suitability and use of this drawing for any structure is the responsibility of the Building Designer per ANSI/TPI 1 Sec.2.
 For more information see these web sites: Alpine: alpineitw.com; TPI: tpinst.org; SBCA: sbccomponents.com; ICC: iccsafe.org; AWC: awc.org

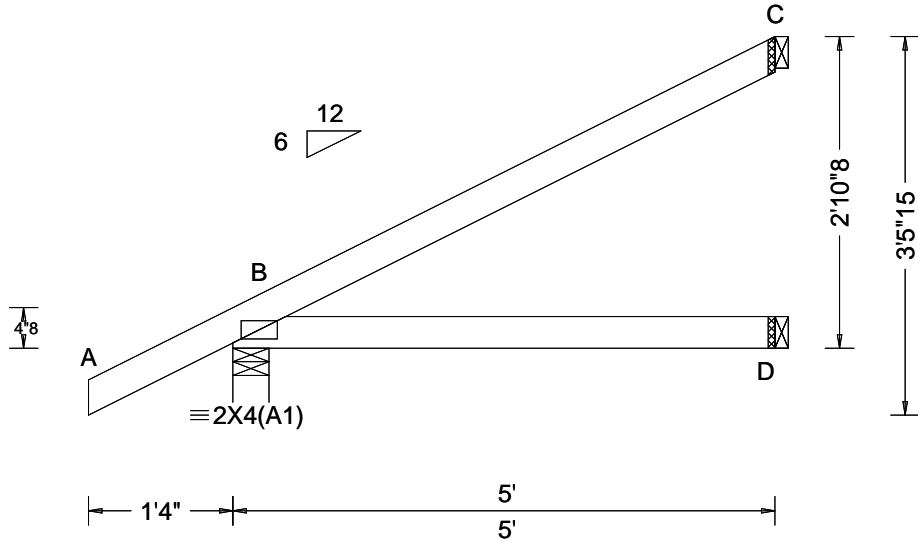

Loading Criteria (psf) TCCL: 20.00 TCCL: 10.00 BCCL: 0.00 BCDL: 10.00 Des Ld: 40.00 NCBCLL: 10.00 Soffit: 2.00 Load Duration: 1.25 Spacing: 24.0 "	Wind Criteria Wind Std: ASCE 7-10 Speed: 130 mph Enclosure: Closed Risk Category: II EXP: C Kzt: NA Mean Height: 15.00 ft TCCL: 5.0 psf BCDL: 5.0 psf MWFRS Parallel Dist: 0 to h/2 C&C Dist a: 3.00 ft Loc. from endwall: not in 4.50 ft GCp: 0.18 Wind Duration: 1.60	Snow Criteria (Pg,Pf in PSF) Pg: NA Ct: NA CAT: NA Pf: NA Ce: NA Lu: NA Cs: NA Snow Duration: NA Building Code: FBC 2017 RES TPI Std: 2014 Rep Fac: Yes FT/RT:20(0)/10(0) Plate Type(s): WAVE	Defl/CSI Criteria PP Deflection in loc L/defl L/# VERT(LL): NA VERT(CL): NA HORZ(LL): 0.004 B - - HORZ(TL): 0.008 B - - Creep Factor: 2.0 Max TC CSI: 0.322 Max BC CSI: 0.238 Max Web CSI: 0.000 VIEW Ver: 21.01.01A.0521.20	▲ Maximum Reactions (lbs) <table border="1"> <thead> <tr> <th rowspan="2">Loc</th> <th colspan="3">Gravity</th> <th colspan="3">Non-Gravity</th> </tr> <tr> <th>R+</th> <th>/R-</th> <th>/Rh</th> <th>/Rw</th> <th>/U</th> <th>/RL</th> </tr> </thead> <tbody> <tr> <td>B</td> <td>316</td> <td>-</td> <td>-</td> <td>/222</td> <td>/43</td> <td>/90</td> </tr> <tr> <td>D</td> <td>90</td> <td>-</td> <td>-</td> <td>/62</td> <td>-</td> <td>-</td> </tr> <tr> <td>C</td> <td>130</td> <td>-</td> <td>-</td> <td>/65</td> <td>/50</td> <td>-</td> </tr> </tbody> </table>	Loc	Gravity			Non-Gravity			R+	/R-	/Rh	/Rw	/U	/RL	B	316	-	-	/222	/43	/90	D	90	-	-	/62	-	-	C	130	-	-	/65	/50	-
				Loc		Gravity			Non-Gravity																													
R+	/R-	/Rh	/Rw		/U	/RL																																
B	316	-	-	/222	/43	/90																																
D	90	-	-	/62	-	-																																
C	130	-	-	/65	/50	-																																
Wind reactions based on MWFRS B Brg Wid = 4.0 Min Req = 1.5 D Brg Wid = 1.5 C Brg Wid = 1.5 Bearing B is a rigid surface. Members not listed have forces less than 375#																																						

Lumber

Top chord: 2x4 SP #2;
 Bot chord: 2x4 SP #2;

Wind

Wind loads based on MWFRS with additional C&C member design.
 Uplifts based on an elevation at or above 1000 ft.

Additional Notes

The overall height of this truss excluding overhang is 2-10-8.

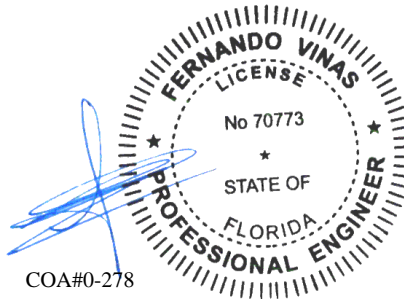

02/28/2022

****WARNING** READ AND FOLLOW ALL NOTES ON THIS DRAWING!**
****IMPORTANT** FURNISH THIS DRAWING TO ALL CONTRACTORS INCLUDING THE INSTALLERS**
 Trusses require extreme care in fabricating, handling, shipping, installing and bracing. Refer to and follow the latest edition of BCSI (Building Component Safety Information, by TPI and SBCA) for safety practices prior to performing these functions. Installers shall provide temporary bracing per BCSI. Unless noted otherwise, top chord shall have properly attached structural sheathing and bottom chord shall have a properly attached rigid ceiling. Locations shown for permanent lateral restraint of webs shall have bracing installed per BCSI sections B3, B7, or B10, as applicable. Apply plates to each face of truss and position as shown above and on the Joint Details, unless noted otherwise. Refer to drawings 160A-Z for standard plate positions. Refer to job's General Notes page for additional information.
 Alpine, a division of ITW Building Components Group Inc. shall not be responsible for any deviation from this drawing, any failure to build the truss in conformance with ANSI/TPI 1, or for handling, shipping, installation and bracing of trusses. A seal on this drawing or cover page listing this drawing, indicates acceptance of professional engineering responsibility solely for the design shown. The suitability and use of this drawing for any structure is the responsibility of the Building Designer per ANSI/TPI 1 Sec.2.
 For more information see these web sites: Alpine: alpineitw.com; TPI: tpinst.org; SBCA: sbccomponents.com; ICC: iccsafe.org; AWC: awc.org



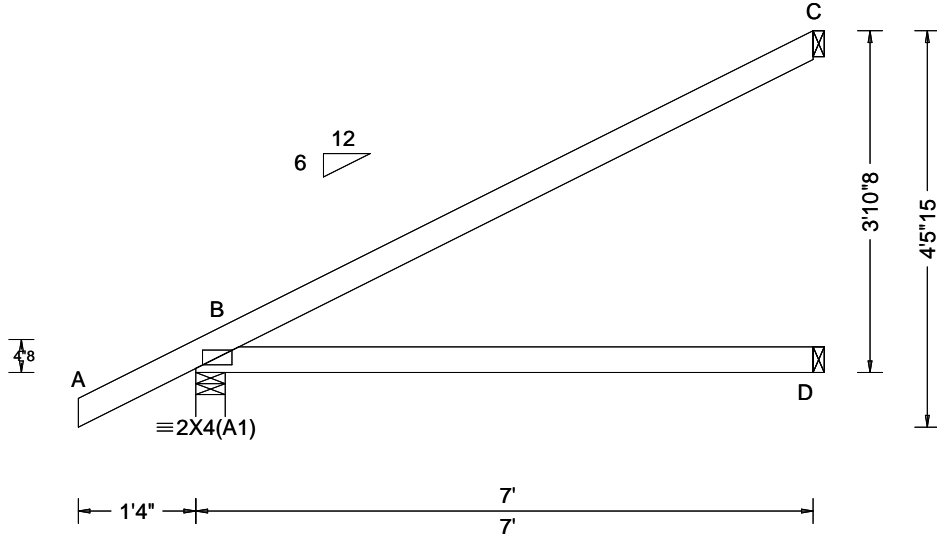

Loading Criteria (psf)	Wind Criteria	Snow Criteria (Pg,Pf in PSF)	Defl/CSI Criteria	▲ Maximum Reactions (lbs)						
				Gravity			Non-Gravity			
				Loc	R+	/R-	/Rh	/Rw	/U	/RL
TCLL: 20.00	Wind Std: ASCE 7-10	Pg: NA Ct: NA CAT: NA	PP Deflection in loc L/defl L/#	B	394	-	-	/272	/48	/118
TCDL: 10.00	Speed: 130 mph	Pf: NA Ce: NA	VERT(LL): NA	D	129	-	-	/90	-	-
BCLL: 0.00	Enclosure: Closed	Lu: NA Cs: NA	VERT(CL): NA	C	189	-	-	/97	/72	-
BCDL: 10.00	Risk Category: II	Snow Duration: NA	HORZ(LL): 0.014 B - -	Wind reactions based on MWFRS						
Des Ld: 40.00	EXP: C Kzt: NA		HORZ(TL): 0.028 B - -	B Brg Wid = 4.0 Min Req = 1.5						
NCBCLL: 10.00	Mean Height: 15.00 ft	Building Code:	Creep Factor: 2.0	D Brg Wid = 1.5						
Soffit: 2.00	TCDL: 5.0 psf	FBC 2017 RES	Max TC CSI: 0.729	C Brg Wid = 1.5						
Load Duration: 1.25	BCDL: 5.0 psf	TPI Std: 2014	Max BC CSI: 0.518	Bearing B is a rigid surface.						
Spacing: 24.0 "	MWFRS Parallel Dist: h/2 to h	Rep Fac: Yes	Max Web CSI: 0.000	Members not listed have forces less than 375#						
	C&C Dist a: 3.00 ft	FT/RT:20(0)/10(0)	VIEW Ver: 21.01.01A.0521.20							
	Loc. from endwall: not in 4.50 ft	Plate Type(s):								
	GCp1: 0.18	WAVE								
	Wind Duration: 1.60									

Lumber

Top chord: 2x4 SP #2;
Bot chord: 2x4 SP #2;

Wind

Wind loads based on MWFRS with additional C&C member design.
Uplifts based on an elevation at or above 1000 ft.

Additional Notes

The overall height of this truss excluding overhang is 3-10-8.

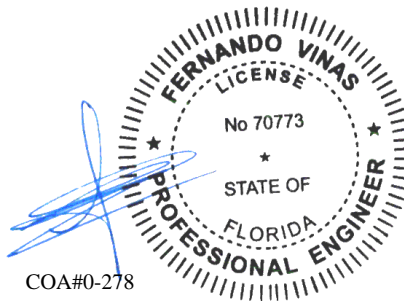

02/28/2022

****WARNING** READ AND FOLLOW ALL NOTES ON THIS DRAWING!**
****IMPORTANT** FURNISH THIS DRAWING TO ALL CONTRACTORS INCLUDING THE INSTALLERS**

Trusses require extreme care in fabricating, handling, shipping, installing and bracing. Refer to and follow the latest edition of BCSI (Building Component Safety Information, by TPI and SBCA) for safety practices prior to performing these functions. Installers shall provide temporary bracing per BCSI. Unless noted otherwise, top chord shall have properly attached structural sheathing and bottom chord shall have a properly attached rigid ceiling. Locations shown for permanent lateral restraint of webs shall have bracing installed per BCSI sections B3, B7, or B10, as applicable. Apply plates to each face of truss and position as shown above and on the Joint Details, unless noted otherwise. Refer to drawings 160A-Z for standard plate positions. Refer to job's General Notes page for additional information.

Alpine, a division of ITW Building Components Group Inc. shall not be responsible for any deviation from this drawing, any failure to build the truss in conformance with ANSI/TPI 1, or for handling, shipping, installation and bracing of trusses. A seal on this drawing or cover page listing this drawing, indicates acceptance of professional engineering responsibility solely for the design shown. The suitability and use of this drawing for any structure is the responsibility of the Building Designer per ANSI/TPI 1 Sec.2.

For more information see these web sites: Alpine: alpineitw.com; TPI: tpinst.org; SBCA: sbcacomponents.com; ICC: iccsafe.org; AWC: awc.org



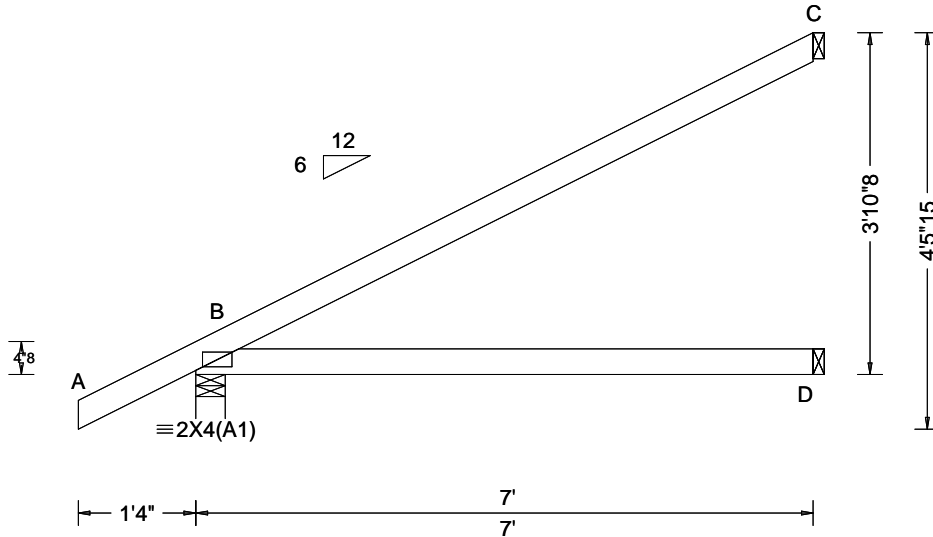

Loading Criteria (psf)	Wind Criteria	Snow Criteria (Pg,Pf in PSF)	Defl/CSI Criteria	▲ Maximum Reactions (lbs)						
				Gravity			Non-Gravity			
TCLL: 20.00	Wind Std: ASCE 7-10	Pg: NA Ct: NA CAT: NA	PP Deflection in loc L/defl L/#	Loc	R+	/R-	/Rh	/Rw	/U	/RL
TCDL: 10.00	Speed: 130 mph	Pf: NA Ce: NA	VERT(LL): NA	B	394	/-	/-	/272	/48	/118
BCLL: 0.00	Enclosure: Closed	Lu: NA Cs: NA	VERT(CL): NA	D	129	/-	/-	/90	/-	/-
BCDL: 10.00	Risk Category: II	Snow Duration: NA	HORZ(LL): 0.014 B - -	C	189	/-	/-	/97	/72	/-
Des Ld: 40.00	EXP: C Kzt: NA	Building Code:	HORZ(TL): 0.028 B - -	Wind reactions based on MWFRS						
NCBCLL: 10.00	Mean Height: 15.00 ft	FBC 2017 RES	Creep Factor: 2.0	B Brg Wid = 4.0 Min Req = 1.5						
Soffit: 2.00	TCDL: 5.0 psf	TPI Std: 2014	Max TC CSI: 0.729	D Brg Wid = 1.5						
Load Duration: 1.25	BCDL: 5.0 psf	Rep Fac: Yes	Max BC CSI: 0.518	C Brg Wid = 1.5						
Spacing: 24.0 "	MWFRS Parallel Dist: h/2 to h	FT/RT:20(0)/10(0)	Max Web CSI: 0.000	Bearing B is a rigid surface.						
	C&C Dist a: 3.00 ft	Plate Type(s):	VIEW Ver: 21.01.01A.0521.20	Members not listed have forces less than 375#						
	Loc. from endwall: not in 9.00 ft	WAVE								
	GCp1: 0.18									
	Wind Duration: 1.60									

Lumber

Top chord: 2x4 SP #2;
Bot chord: 2x4 SP #2;

Wind

Wind loads based on MWFRS with additional C&C member design.
Uplifts based on an elevation at or above 1000 ft.

Additional Notes

The overall height of this truss excluding overhang is 3-10-8.

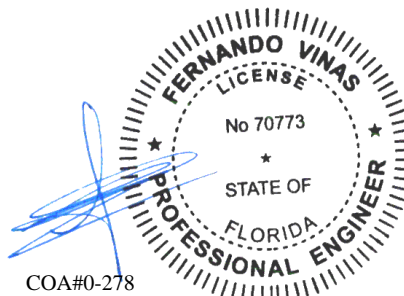

COA#0-278

02/28/2022

****WARNING** READ AND FOLLOW ALL NOTES ON THIS DRAWING!**
****IMPORTANT** FURNISH THIS DRAWING TO ALL CONTRACTORS INCLUDING THE INSTALLERS**
Trusses require extreme care in fabricating, handling, shipping, installing and bracing. Refer to and follow the latest edition of BCSI (Building Component Safety Information, by TPI and SBCA) for safety practices prior to performing these functions. Installers shall provide temporary bracing per BCSI. Unless noted otherwise, top chord shall have properly attached structural sheathing and bottom chord shall have a properly attached rigid ceiling. Locations shown for permanent lateral restraint of webs shall have bracing installed per BCSI sections B3, B7, or B10, as applicable. Apply plates to each face of truss and position as shown above and on the Joint Details, unless noted otherwise. Refer to drawings 160A-Z for standard plate positions. Refer to job's General Notes page for additional information.
Alpine, a division of ITW Building Components Group Inc. shall not be responsible for any deviation from this drawing, any failure to build the truss in conformance with ANSI/TPI 1, or for handling, shipping, installation and bracing of trusses. A seal on this drawing or cover page listing this drawing, indicates acceptance of professional engineering responsibility solely for the design shown. The suitability and use of this drawing for any structure is the responsibility of the Building Designer per ANSI/TPI 1 Sec.2.
For more information see these web sites: Alpine: alpineitw.com; TPI: tpinst.org; SBCA: sbcacomponents.com; ICC: iccsafe.org; AWC: awc.org



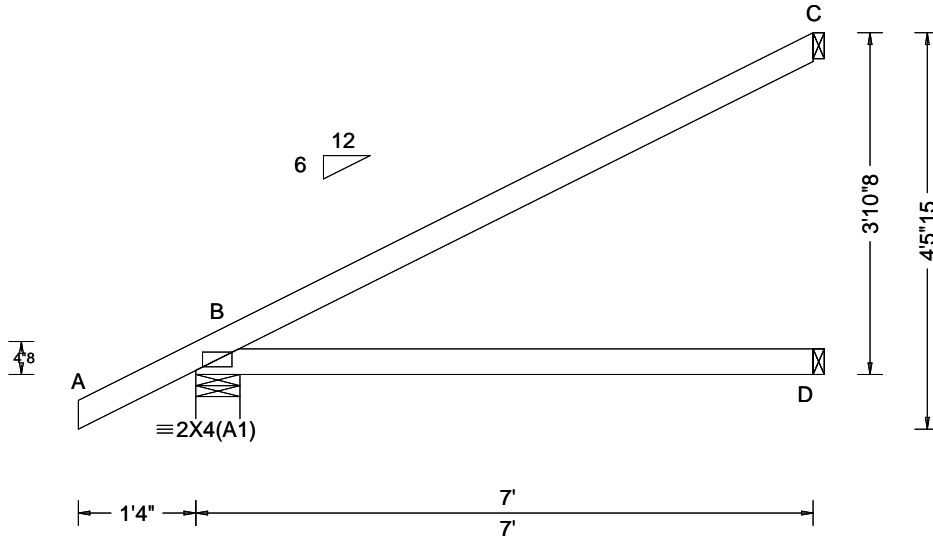

Loading Criteria (psf) TCCL: 20.00 TCCL: 10.00 BCLL: 0.00 BCDL: 10.00 Des Ld: 40.00 NCBCLL: 10.00 Soffit: 2.00 Load Duration: 1.25 Spacing: 24.0 "	Wind Criteria Wind Std: ASCE 7-10 Speed: 130 mph Enclosure: Closed Risk Category: II EXP: C Kzt: NA Mean Height: 15.00 ft TCCL: 5.0 psf BCDL: 5.0 psf MWFRS Parallel Dist: h/2 to h C&C Dist a: 3.00 ft Loc. from endwall: not in 4.50 ft GCp1: 0.18 Wind Duration: 1.60	Snow Criteria (Pg,Pf in PSF) Pg: NA Ct: NA CAT: NA Pf: NA Ce: NA Lu: NA Cs: NA Snow Duration: NA Building Code: FBC 2017 RES TPI Std: 2014 Rep Fac: Yes FT/RT:20(0)/10(0) Plate Type(s): WAVE	Defl/CSI Criteria PP Deflection in loc L/defl L/# VERT(LL): NA VERT(CL): NA HORZ(LL): 0.014 B - - HORZ(TL): 0.028 B - - Creep Factor: 2.0 Max TC CSI: 0.729 Max BC CSI: 0.518 Max Web CSI: 0.000 VIEW Ver: 21.01.01A.0521.20	▲ Maximum Reactions (lbs) <table border="1"> <thead> <tr> <th rowspan="2">Loc</th> <th colspan="3">Gravity</th> <th colspan="3">Non-Gravity</th> </tr> <tr> <th>R+</th> <th>/R-</th> <th>/Rh</th> <th>/Rw</th> <th>/U</th> <th>/RL</th> </tr> </thead> <tbody> <tr> <td>B</td> <td>394</td> <td>-</td> <td>-</td> <td>/272</td> <td>/48</td> <td>/118</td> </tr> <tr> <td>D</td> <td>129</td> <td>-</td> <td>-</td> <td>/90</td> <td>-</td> <td>-</td> </tr> <tr> <td>C</td> <td>189</td> <td>-</td> <td>-</td> <td>/97</td> <td>/72</td> <td>-</td> </tr> </tbody> </table>	Loc	Gravity			Non-Gravity			R+	/R-	/Rh	/Rw	/U	/RL	B	394	-	-	/272	/48	/118	D	129	-	-	/90	-	-	C	189	-	-	/97	/72	-
				Loc		Gravity			Non-Gravity																													
R+	/R-	/Rh	/Rw		/U	/RL																																
B	394	-	-	/272	/48	/118																																
D	129	-	-	/90	-	-																																
C	189	-	-	/97	/72	-																																
Wind reactions based on MWFRS B Brg Wid = 6.0 Min Req = 1.5 D Brg Wid = 1.5 C Brg Wid = 1.5 Bearing B is a rigid surface. Members not listed have forces less than 375#																																						

Lumber

Top chord: 2x4 SP #2;
 Bot chord: 2x4 SP #2;

Wind

Wind loads based on MWFRS with additional C&C member design.
 Uplifts based on an elevation at or above 1000 ft.

Additional Notes

The overall height of this truss excluding overhang is 3-10-8.

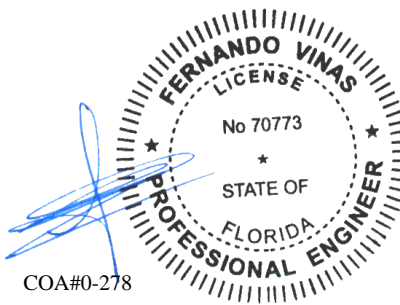

02/28/2022

****WARNING** READ AND FOLLOW ALL NOTES ON THIS DRAWING!**
****IMPORTANT** FURNISH THIS DRAWING TO ALL CONTRACTORS INCLUDING THE INSTALLERS**
 Trusses require extreme care in fabricating, handling, shipping, installing and bracing. Refer to and follow the latest edition of BCSI (Building Component Safety Information, by TPI and SBCA) for safety practices prior to performing these functions. Installers shall provide temporary bracing per BCSI. Unless noted otherwise, top chord shall have properly attached structural sheathing and bottom chord shall have a properly attached rigid ceiling. Locations shown for permanent lateral restraint of webs shall have bracing installed per BCSI sections B3, B7, or B10, as applicable. Apply plates to each face of truss and position as shown above and on the Joint Details, unless noted otherwise. Refer to drawings 160A-Z for standard plate positions. Refer to job's General Notes page for additional information.
 Alpine, a division of ITW Building Components Group Inc. shall not be responsible for any deviation from this drawing, any failure to build the truss in conformance with ANSI/TPI 1, or for handling, shipping, installation and bracing of trusses. A seal on this drawing or cover page listing this drawing, indicates acceptance of professional engineering responsibility solely for the design shown. The suitability and use of this drawing for any structure is the responsibility of the Building Designer per ANSI/TPI 1 Sec.2.
 For more information see these web sites: Alpine: alpineitw.com; TPI: tpinst.org; SBCA: sbcacomponents.com; ICC: iccsafe.org; AWC: awc.org



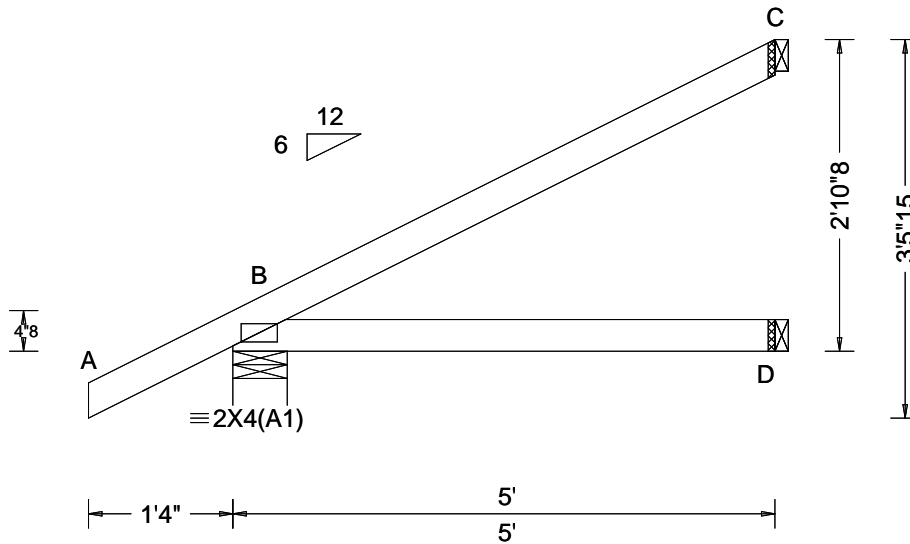

Loading Criteria (psf) TCCL: 20.00 TCCL: 10.00 BCCL: 0.00 BCDL: 10.00 Des Ld: 40.00 NCBCLL: 10.00 Soffit: 2.00 Load Duration: 1.25 Spacing: 24.0 "	Wind Criteria Wind Std: ASCE 7-10 Speed: 130 mph Enclosure: Closed Risk Category: II EXP: C Kzt: NA Mean Height: 15.00 ft TCCL: 5.0 psf BCDL: 5.0 psf MWFRS Parallel Dist: 0 to h/2 C&C Dist a: 3.00 ft Loc. from endwall: not in 4.50 ft GCp: 0.18 Wind Duration: 1.60	Snow Criteria (Pg,Pf in PSF) Pg: NA Ct: NA CAT: NA Pf: NA Ce: NA Lu: NA Cs: NA Snow Duration: NA Building Code: FBC 2017 RES TPI Std: 2014 Rep Fac: Yes FT/RT:20(0)/10(0) Plate Type(s): WAVE	Defl/CSI Criteria PP Deflection in loc L/defl L/# VERT(LL): NA VERT(CL): NA HORZ(LL): 0.004 B - - HORZ(TL): 0.008 B - - Creep Factor: 2.0 Max TC CSI: 0.322 Max BC CSI: 0.238 Max Web CSI: 0.000 VIEW Ver: 21.01.01A.0521.20	▲ Maximum Reactions (lbs) Gravity <table border="1"> <thead> <tr> <th>Loc</th> <th>R+</th> <th>/R-</th> <th>/Rh</th> <th>/Rw</th> <th>/U</th> <th>/RL</th> </tr> </thead> <tbody> <tr> <td>B</td> <td>316</td> <td>-</td> <td>-</td> <td>/222</td> <td>/43</td> <td>/90</td> </tr> <tr> <td>D</td> <td>90</td> <td>-</td> <td>-</td> <td>/62</td> <td>-</td> <td>-</td> </tr> <tr> <td>C</td> <td>130</td> <td>-</td> <td>-</td> <td>/65</td> <td>/50</td> <td>-</td> </tr> </tbody> </table> Non-Gravity Wind reactions based on MWFRS B Brg Wid = 6.0 Min Req = 1.5 D Brg Wid = 1.5 C Brg Wid = 1.5 Bearing B is a rigid surface. Members not listed have forces less than 375#	Loc	R+	/R-	/Rh	/Rw	/U	/RL	B	316	-	-	/222	/43	/90	D	90	-	-	/62	-	-	C	130	-	-	/65	/50	-
				Loc	R+	/R-	/Rh	/Rw	/U	/RL																						
B	316	-	-	/222	/43	/90																										
D	90	-	-	/62	-	-																										
C	130	-	-	/65	/50	-																										
Lumber Top chord: 2x4 SP #2; Bot chord: 2x4 SP #2; Wind Wind loads based on MWFRS with additional C&C member design. Uplifts based on an elevation at or above 1000 ft. Additional Notes The overall height of this truss excluding overhang is 2-10-8.																																

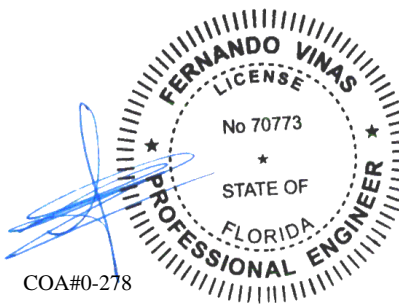

COA#0-278

02/28/2022

****WARNING** READ AND FOLLOW ALL NOTES ON THIS DRAWING!**
****IMPORTANT** FURNISH THIS DRAWING TO ALL CONTRACTORS INCLUDING THE INSTALLERS**
 Trusses require extreme care in fabricating, handling, shipping, installing and bracing. Refer to and follow the latest edition of BCSI (Building Component Safety Information, by TPI and SBCA) for safety practices prior to performing these functions. Installers shall provide temporary bracing per BCSI. Unless noted otherwise, top chord shall have properly attached structural sheathing and bottom chord shall have a properly attached rigid ceiling. Locations shown for permanent lateral restraint of webs shall have bracing installed per BCSI sections B3, B7, or B10, as applicable. Apply plates to each face of truss and position as shown above and on the Joint Details, unless noted otherwise. Refer to drawings 160A-Z for standard plate positions. Refer to job's General Notes page for additional information.
 Alpine, a division of ITW Building Components Group Inc. shall not be responsible for any deviation from this drawing, any failure to build the truss in conformance with ANSI/TPI 1, or for handling, shipping, installation and bracing of trusses. A seal on this drawing or cover page listing this drawing, indicates acceptance of professional engineering responsibility solely for the design shown. The suitability and use of this drawing for any structure is the responsibility of the Building Designer per ANSI/TPI 1 Sec.2.
 For more information see these web sites: Alpine: alpineitw.com; TPI: tpinst.org; SBCA: sbcacomponents.com; ICC: iccsafe.org; AWC: awc.org



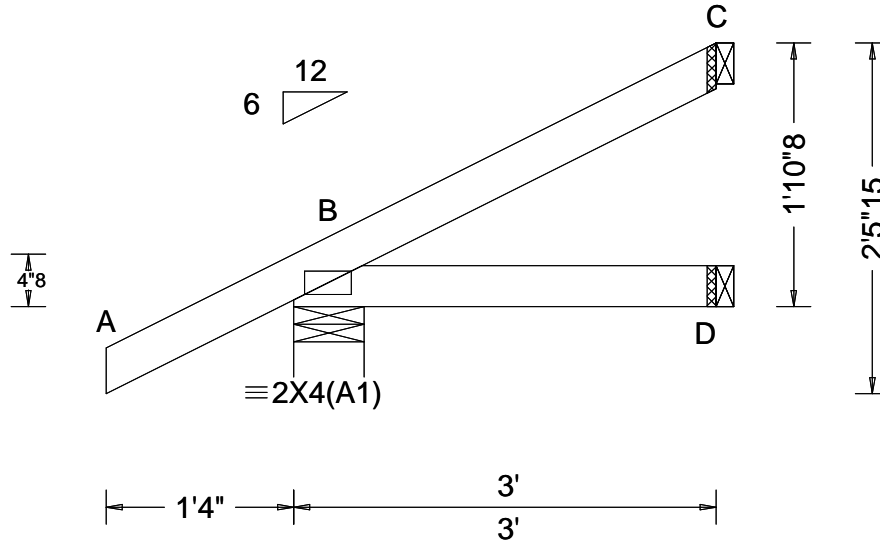

Loading Criteria (psf)	Wind Criteria	Snow Criteria (Pg,Pf in PSF)	Defl/CSI Criteria	▲ Maximum Reactions (lbs)						
				Gravity			Non-Gravity			
TCLL: 20.00	Wind Std: ASCE 7-10	Pg: NA Ct: NA CAT: NA	PP Deflection in loc L/def L/#	Loc	R+	/R-	/Rh	/Rw	/U	/RL
TCDL: 10.00	Speed: 130 mph	Pf: NA Ce: NA	VERT(LL): NA	B	244	/-	/-	/177	/39	/61
BCLL: 0.00	Enclosure: Closed	Lu: NA Cs: NA	VERT(CL): NA	D	50	/-	/-	/38	/-	/-
BCDL: 10.00	Risk Category: II	Snow Duration: NA	HORZ(LL): 0.001 B - -	C	66	/-	/-	/29	/26	/-
Des Ld: 40.00	EXP: C Kzt: NA		HORZ(TL): 0.001 B - -	Wind reactions based on MWFRS						
NCBCLL: 10.00	Mean Height: 15.00 ft	Building Code:	Creep Factor: 2.0	B Brg Wid = 6.0 Min Req = 1.5						
Soffit: 2.00	TCDL: 5.0 psf	FBC 2017 RES	Max TC CSI: 0.205	D Brg Wid = 1.5						
Load Duration: 1.25	BCDL: 5.0 psf	TPI Std: 2014	Max BC CSI: 0.067	C Brg Wid = 1.5						
Spacing: 24.0 "	MWFRS Parallel Dist: 0 to h/2	Rep Fac: Yes	Max Web CSI: 0.000	Bearing B is a rigid surface.						
	C&C Dist a: 3.00 ft	FT/RT:20(0)/10(0)		Members not listed have forces less than 375#						
	Loc. from endwall: Any	Plate Type(s):	VIEW Ver: 21.01.01A.0521.20							
	GCp: 0.18	WAVE								
	Wind Duration: 1.60									

Lumber

Top chord: 2x4 SP #2;
Bot chord: 2x4 SP #2;

Wind

Wind loads based on MWFRS with additional C&C member design.
Uplifts based on an elevation at or above 1000 ft.

Additional Notes

The overall height of this truss excluding overhang is 1-10-8.

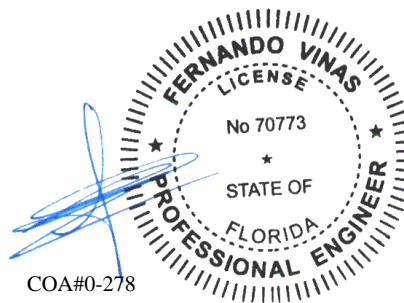

COA#0-278

02/28/2022

****WARNING** READ AND FOLLOW ALL NOTES ON THIS DRAWING!**
****IMPORTANT** FURNISH THIS DRAWING TO ALL CONTRACTORS INCLUDING THE INSTALLERS**
Trusses require extreme care in fabricating, handling, shipping, installing and bracing. Refer to and follow the latest edition of BCSI (Building Component Safety Information, by TPI and SBCA) for safety practices prior to performing these functions. Installers shall provide temporary bracing per BCSI. Unless noted otherwise, top chord shall have properly attached structural sheathing and bottom chord shall have a properly attached rigid ceiling. Locations shown for permanent lateral restraint of webs shall have bracing installed per BCSI sections B3, B7, or B10, as applicable. Apply plates to each face of truss and position as shown above and on the Joint Details, unless noted otherwise. Refer to drawings 160A-Z for standard plate positions. Refer to job's General Notes page for additional information.
Alpine, a division of ITW Building Components Group Inc. shall not be responsible for any deviation from this drawing, any failure to build the truss in conformance with ANSI/TPI 1, or for handling, shipping, installation and bracing of trusses. A seal on this drawing or cover page listing this drawing, indicates acceptance of professional engineering responsibility solely for the design shown. The suitability and use of this drawing for any structure is the responsibility of the Building Designer per ANSI/TPI 1 Sec.2.
For more information see these web sites: Alpine: alpineitw.com; TPI: tpinst.org; SBCA: sbcacomponents.com; ICC: iccsafe.org; AWC: awc.org



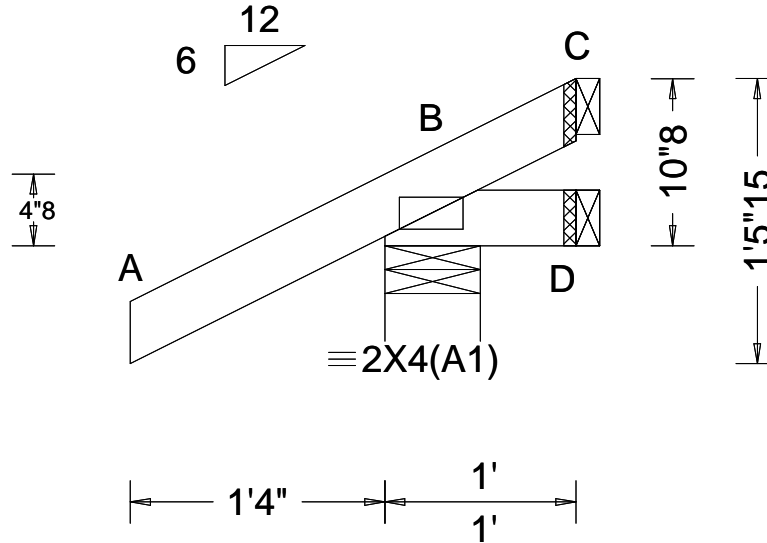

Loading Criteria (psf) TCCL: 20.00 TCCL: 10.00 BCLL: 0.00 BCDL: 10.00 Des Ld: 40.00 NCBCLL: 10.00 Soffit: 2.00 Load Duration: 1.25 Spacing: 24.0 "	Wind Criteria Wind Std: ASCE 7-10 Speed: 130 mph Enclosure: Closed Risk Category: II EXP: C Kzt: NA Mean Height: 15.00 ft TCCL: 5.0 psf BCDL: 5.0 psf MWFRS Parallel Dist: 0 to h/2 C&C Dist a: 3.00 ft Loc. from endwall: Any GCp: 0.18 Wind Duration: 1.60	Snow Criteria (Pg,Pf in PSF) Pg: NA Ct: NA CAT: NA Pf: NA Ce: NA Lu: NA Cs: NA Snow Duration: NA Building Code: FBC 2017 RES TPI Std: 2014 Rep Fac: Yes FT/RT:20(0)/10(0) Plate Type(s): WAVE	Defl/CSI Criteria PP Deflection in loc L/defl L/# VERT(LL): NA VERT(CL): NA HORZ(LL): -0.000 B - - HORZ(TL): 0.000 B - - Creep Factor: 2.0 Max TC CSI: 0.199 Max BC CSI: 0.029 Max Web CSI: 0.000 VIEW Ver: 21.01.01A.0521.20	▲ Maximum Reactions (lbs) <table border="1"> <thead> <tr> <th rowspan="2">Loc</th> <th colspan="3">Gravity</th> <th colspan="3">Non-Gravity</th> </tr> <tr> <th>R+</th> <th>/R-</th> <th>/Rh</th> <th>/Rw</th> <th>/U</th> <th>/RL</th> </tr> </thead> <tbody> <tr> <td>B</td> <td>222</td> <td>/-</td> <td>/-</td> <td>/175</td> <td>/57</td> <td>/32</td> </tr> <tr> <td>D</td> <td>7</td> <td>/-11</td> <td>/-</td> <td>/15</td> <td>/12</td> <td>/-</td> </tr> <tr> <td>C</td> <td>-</td> <td>/-40</td> <td>/-</td> <td>/25</td> <td>/42</td> <td>/-</td> </tr> </tbody> </table>	Loc	Gravity			Non-Gravity			R+	/R-	/Rh	/Rw	/U	/RL	B	222	/-	/-	/175	/57	/32	D	7	/-11	/-	/15	/12	/-	C	-	/-40	/-	/25	/42	/-
				Loc		Gravity			Non-Gravity																													
R+	/R-	/Rh	/Rw		/U	/RL																																
B	222	/-	/-	/175	/57	/32																																
D	7	/-11	/-	/15	/12	/-																																
C	-	/-40	/-	/25	/42	/-																																
Wind reactions based on MWFRS B Brg Wid = 6.0 Min Req = 1.5 D Brg Wid = 1.5 C Brg Wid = 1.5 Bearing B is a rigid surface. Members not listed have forces less than 375#																																						

Lumber

Top chord: 2x4 SP #2;
 Bot chord: 2x4 SP #2;

Wind

Wind loads based on MWFRS with additional C&C member design.
 Uplifts based on an elevation at or above 1000 ft.

Additional Notes

The overall height of this truss excluding overhang is 0-10-8.

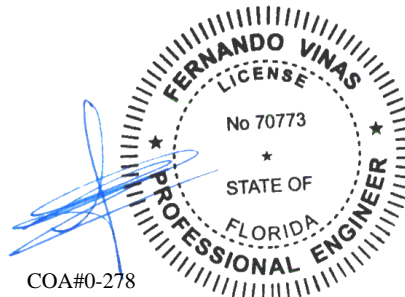

COA#0-278

02/28/2022

****WARNING** READ AND FOLLOW ALL NOTES ON THIS DRAWING!**
****IMPORTANT** FURNISH THIS DRAWING TO ALL CONTRACTORS INCLUDING THE INSTALLERS**
 Trusses require extreme care in fabricating, handling, shipping, installing and bracing. Refer to and follow the latest edition of BCSI (Building Component Safety Information, by TPI and SBCA) for safety practices prior to performing these functions. Installers shall provide temporary bracing per BCSI. Unless noted otherwise, top chord shall have properly attached structural sheathing and bottom chord shall have a properly attached rigid ceiling. Locations shown for permanent lateral restraint of webs shall have bracing installed per BCSI sections B3, B7, or B10, as applicable. Apply plates to each face of truss and position as shown above and on the Joint Details, unless noted otherwise. Refer to drawings 160A-Z for standard plate positions. Refer to job's General Notes page for additional information.
 Alpine, a division of ITW Building Components Group Inc. shall not be responsible for any deviation from this drawing, any failure to build the truss in conformance with ANSI/TPI 1, or for handling, shipping, installation and bracing of trusses. A seal on this drawing or cover page listing this drawing, indicates acceptance of professional engineering responsibility solely for the design shown. The suitability and use of this drawing for any structure is the responsibility of the Building Designer per ANSI/TPI 1 Sec.2.
 For more information see these web sites: Alpine: alpineitw.com; TPI: tpinst.org; SBCA: sbccomponents.com; ICC: iccsafe.org; AWC: awc.org



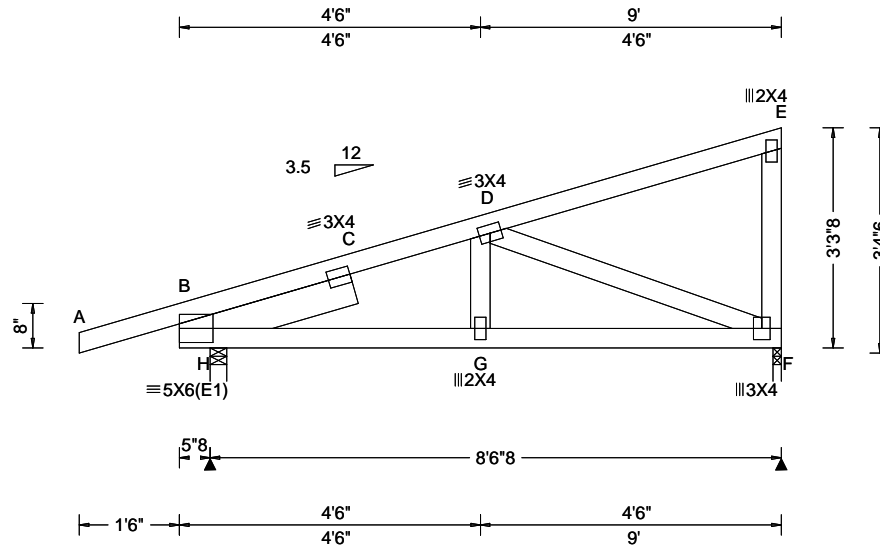

Loading Criteria (psf) TCLL: 20.00 TCDL: 10.00 BCLL: 0.00 BCDL: 10.00 Des Ld: 40.00 NCBCLL: 10.00 Soffit: 2.00 Load Duration: 1.25 Spacing: 24.0 "	Wind Criteria Wind Std: ASCE 7-10 Speed: 130 mph Enclosure: Closed Risk Category: II EXP: C Kzt: NA Mean Height: 15.00 ft TCDL: 5.0 psf BCDL: 5.0 psf MWFRS Parallel Dist: h to 2h C&C Dist a: 3.00 ft Loc. from endwall: not in 9.00 ft GCp: 0.18 Wind Duration: 1.60	Snow Criteria (Pg,Pf in PSF) Pg: NA Ct: NA CAT: NA Pf: NA Ce: NA Lu: NA Cs: NA Snow Duration: NA Building Code: FBC 2017 RES TPI Std: 2014 Rep Fac: Yes FT/RT:20(0)/10(0) Plate Type(s): WAVE	Defl/CSI Criteria PP Deflection in loc L/def L/# VERT(LL): 0.018 C 999 240 VERT(CL): 0.035 C 999 180 HORZ(LL): 0.005 C - - HORZ(TL): 0.011 C - - Creep Factor: 2.0 Max TC CSI: 0.218 Max BC CSI: 0.246 Max Web CSI: 0.245 VIEW Ver: 21.01.01A.0521.20	▲ Maximum Reactions (lbs) Gravity Non-Gravity Loc R+ / R- / Rh / Rw / U / RL H 469 /- /- /306 /83 /72 F 356 /- /- /216 /33 /- Wind reactions based on MWFRS H Brg Wid = 3.0 Min Req = 1.5 F Brg Wid = 1.5 Min Req = 1.5 Bearings H & F are a rigid surface. Members not listed have forces less than 375# Maximum Top Chord Forces Per Ply (lbs) Chords Tens.Comp. Chords Tens. Comp. B - C 111 -637 C - D 116 -568
--	--	---	--	---

Lumber

Top chord: 2x4 SP #2;
Bot chord: 2x4 SP #2;
Webs: 2x4 SP #3;
Lt Slider: 2x6 SP #2; block length = 2.674'

Wind

Wind loads based on MWFRS with additional C&C member design.
Right end vertical not exposed to wind pressure.
Left cantilever is exposed to wind
Uplifts based on an elevation at or above 1000 ft.

Additional Notes

The overall height of this truss excluding overhang is 3-3-8.

Maximum Bot Chord Forces Per Ply (lbs)

Chords	Tens.Comp.	Chords	Tens. Comp.
B - G	546 -191	G - F	539 -192

Maximum Web Forces Per Ply (lbs)

Webs	Tens.Comp.
D - F	203 -572

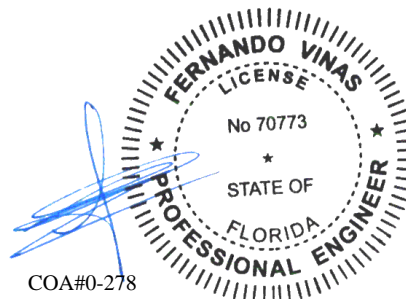

COA#0-278

02/28/2022

****WARNING** READ AND FOLLOW ALL NOTES ON THIS DRAWING!**
****IMPORTANT** FURNISH THIS DRAWING TO ALL CONTRACTORS INCLUDING THE INSTALLERS**
Trusses require extreme care in fabricating, handling, shipping, installing and bracing. Refer to and follow the latest edition of BCSI (Building Component Safety Information, by TPI and SBCA) for safety practices prior to performing these functions. Installers shall provide temporary bracing per BCSI. Unless noted otherwise, top chord shall have properly attached structural sheathing and bottom chord shall have a properly attached rigid ceiling. Locations shown for permanent lateral restraint of webs shall have bracing installed per BCSI sections B3, B7, or B10, as applicable. Apply plates to each face of truss and position as shown above and on the Joint Details, unless noted otherwise. Refer to drawings 160A-Z for standard plate positions. Refer to job's General Notes page for additional information.
Alpine, a division of ITW Building Components Group Inc. shall not be responsible for any deviation from this drawing, any failure to build the truss in conformance with ANSI/TPI 1, or for handling, shipping, installation and bracing of trusses. A seal on this drawing or cover page listing this drawing, indicates acceptance of professional engineering responsibility solely for the design shown. The suitability and use of this drawing for any structure is the responsibility of the Building Designer per ANSI/TPI 1 Sec.2.
For more information see these web sites: Alpine: alpineitw.com; TPI: tpinst.org; SBCA: sbccomponents.com; ICC: iccsafe.org; AWC: awc.org



SEQN: 647467 FROM: CDM	GABL Ply: 1 Qty: 1	Job Number: 22-6970 Jordan - Lancaster Model Truss Label: J11	Cust: R 215 JRef: 1Xdd2150013 T22 DrwNo: 059.22.1344.33327 GA / FV 02/28/2022
---------------------------	--------------------------	---	---

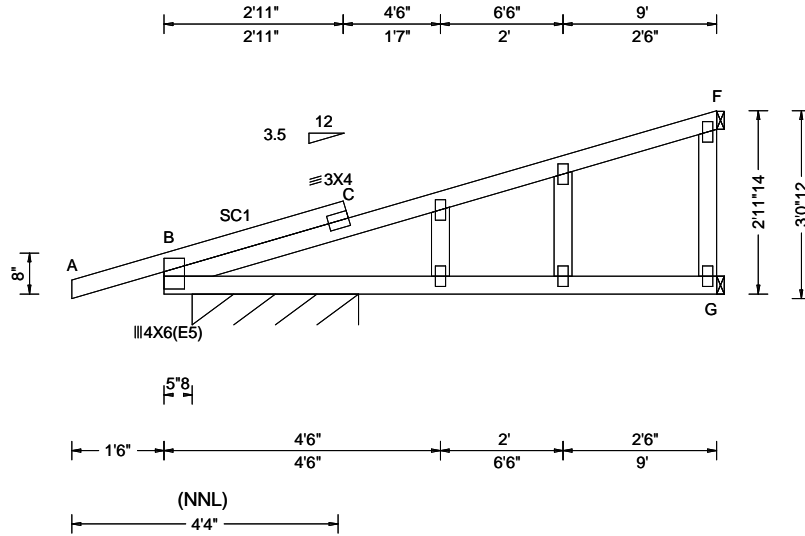

Loading Criteria (psf) TCLL: 20.00 TCDL: 10.00 BCLL: 0.00 BCDL: 10.00 Des Ld: 40.00 NCBCLL: 10.00 Soffit: 2.00 Load Duration: 1.25 Spacing: 24.0 "	Wind Criteria Wind Std: ASCE 7-10 Speed: 130 mph Enclosure: Closed Risk Category: II EXP: C Kzt: NA Mean Height: 15.00 ft TCDL: 5.0 psf BCDL: 5.0 psf MWFRS Parallel Dist: > 2h C&C Dist a: 3.00 ft Loc. from endwall: not in 9.00 ft GCp: 0.18 Wind Duration: 1.60	Snow Criteria (Pg,Pf in PSF) Pg: NA Ct: NA CAT: NA Pf: NA Ce: NA Lu: NA Cs: NA Snow Duration: NA Building Code: FBC 2017 RES TPI Std: 2014 Rep Fac: Yes FT/RT:20(0)/10(0) Plate Type(s): WAVE	Defl/CSI Criteria PP Deflection in loc L/def L/# VERT(LL): 0.057 H 999 240 VERT(CL): 0.110 H 634 180 HORZ(LL): 0.015 E - - HORZ(TL): 0.029 E - - Creep Factor: 2.0 Max TC CSI: 0.311 Max BC CSI: 0.416 Max Web CSI: 0.107 VIEW Ver: 21.01.01A.0521.20	▲ Maximum Reactions (lbs), or *=PLF Gravity Loc R+ / R- / Rh / Rw / U / RL Non-Gravity B* 222 /- /- /154 /18 /17 G 87 /- /- /64 /- /- F 130 /- /- /58 /- /- Wind reactions based on MWFRS B Brg Wid = 32.5 Min Req = - G Brg Wid = 1.5 F Brg Wid = 1.5 Bearing B is a rigid surface. Members not listed have forces less than 375#
--	---	---	--	---

Lumber

Top chord: 2x4 SP #2;
Bot chord: 2x4 SP #2;
Webs: 2x4 SP #3;
Stack Chord: SC1 2x4 SP #2;

Plating Notes

All plates are 2X4 except as noted.

Loading

Gable end supports 8" max rake overhang. Top chord must not be cut or notched.

Wind

Wind loads based on MWFRS with additional C&C member design.

Right end vertical not exposed to wind pressure.

Left cantilever is exposed to wind

Uplifts based on an elevation at or above 1000 ft.

Additional Notes

See DWGS A14015ENC101014 & GBLLETIN0118 for gable wind bracing and other requirements.

Stacked top chord must NOT be notched or cut in area (NNL). Dropped top chord braced at 24" oc intervals. Attach stacked top chord (SC) to dropped top chord in notchable area using 3x4 tie-plates 24" oc. Center plate on stacked/dropped chord interface, plate length perpendicular to chord length. Splice top chord in notchable area using 3x6.

The overall height of this truss excluding overhang is 2-11-14.

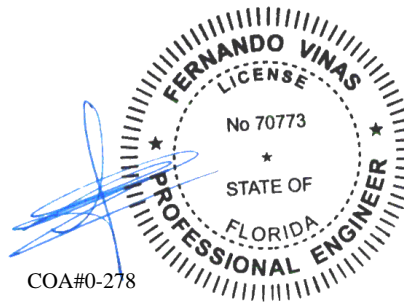

COA#0-278

02/28/2022

****WARNING** READ AND FOLLOW ALL NOTES ON THIS DRAWING!**
****IMPORTANT** FURNISH THIS DRAWING TO ALL CONTRACTORS INCLUDING THE INSTALLERS**
Trusses require extreme care in fabricating, handling, shipping, installing and bracing. Refer to and follow the latest edition of BCSI (Building Component Safety Information, by TPI and SBCA) for safety practices prior to performing these functions. Installers shall provide temporary bracing per BCSI. Unless noted otherwise, top chord shall have properly attached structural sheathing and bottom chord shall have a properly attached rigid ceiling. Locations shown for permanent lateral restraint of webs shall have bracing installed per BCSI sections B3, B7, or B10, as applicable. Apply plates to each face of truss and position as shown above and on the Joint Details, unless noted otherwise. Refer to drawings 160A-Z for standard plate positions. Refer to job's General Notes page for additional information.
Alpine, a division of ITW Building Components Group Inc. shall not be responsible for any deviation from this drawing, any failure to build the truss in conformance with ANSI/TPI 1, or for handling, shipping, installation and bracing of trusses. A seal on this drawing or cover page listing this drawing, indicates acceptance of professional engineering responsibility solely for the design shown. The suitability and use of this drawing for any structure is the responsibility of the Building Designer per ANSI/TPI 1 Sec.2.
For more information see these web sites: Alpine: alpineitw.com; TPI: tpinst.org; SBCA: sbcacomponents.com; ICC: iccsafe.org; AWC: awc.org



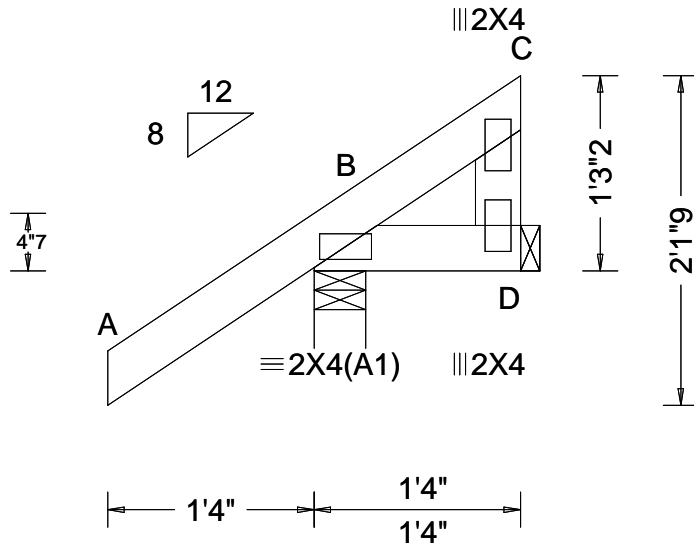

Loading Criteria (psf)	Wind Criteria	Snow Criteria (Pg,Pf in PSF)	Defl/CSI Criteria	▲ Maximum Reactions (lbs)
TCLL: 20.00 TCDL: 10.00 BCLL: 0.00 BCDL: 10.00 Des Ld: 40.00 NCBCLL: 10.00 Soffit: 2.00 Load Duration: 1.25 Spacing: 24.0 "	Wind Std: ASCE 7-10 Speed: 130 mph Enclosure: Closed Risk Category: II EXP: C Kzt: NA Mean Height: 15.00 ft TCDL: 5.0 psf BCDL: 5.0 psf MWFRS Parallel Dist: 0 to h/2 C&C Dist a: 3.00 ft Loc. from endwall: Any GCp: 0.18 Wind Duration: 1.60	Pg: NA Ct: NA CAT: NA Pf: NA Ce: NA Lu: NA Cs: NA Snow Duration: NA Building Code: FBC 2017 RES TPI Std: 2014 Rep Fac: Yes FT/RT:20(0)/10(0) Plate Type(s): WAVE	PP Deflection in loc L/def L/# VERT(LL): NA VERT(CL): NA HORZ(LL): -0.000 B - - HORZ(TL): 0.001 B - - Creep Factor: 2.0 Max TC CSI: 0.131 Max BC CSI: 0.022 Max Web CSI: 0.008 VIEW Ver: 21.01.01A.0521.20	Gravity Non-Gravity Loc R+ / R- / Rh / Rw / U / RL B 218 /- /- /177 /40 /49 D 11 /-14 /- /37 /32 /- Wind reactions based on MWFRS B Brg Wid = 4.0 Min Req = 1.5 D Brg Wid = 1.5 Bearing B is a rigid surface. Members not listed have forces less than 375#

Lumber

Top chord: 2x4 SP #2;
Bot chord: 2x4 SP #2;
Webs: 2x4 SP #3;

Wind

Wind loads based on MWFRS with additional C&C member design.
Right end vertical not exposed to wind pressure.
Uplifts based on an elevation at or above 1000 ft.

Additional Notes

The overall height of this truss excluding overhang is 1-3-2.

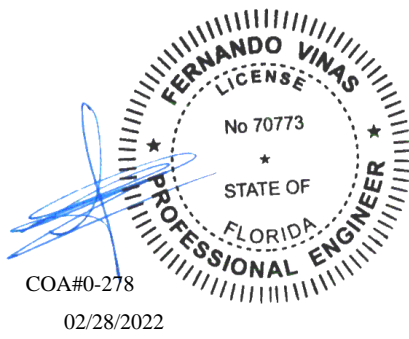

****WARNING** READ AND FOLLOW ALL NOTES ON THIS DRAWING!**
****IMPORTANT** FURNISH THIS DRAWING TO ALL CONTRACTORS INCLUDING THE INSTALLERS**
Trusses require extreme care in fabricating, handling, shipping, installing and bracing. Refer to and follow the latest edition of BCSI (Building Component Safety Information, by TPI and SBCA) for safety practices prior to performing these functions. Installers shall provide temporary bracing per BCSI. Unless noted otherwise, top chord shall have properly attached structural sheathing and bottom chord shall have a properly attached rigid ceiling. Locations shown for permanent lateral restraint of webs shall have bracing installed per BCSI sections B3, B7, or B10, as applicable. Apply plates to each face of truss and position as shown above and on the Joint Details, unless noted otherwise. Refer to drawings 160A-Z for standard plate positions. Refer to job's General Notes page for additional information.
Alpine, a division of ITW Building Components Group Inc. shall not be responsible for any deviation from this drawing, any failure to build the truss in conformance with ANSI/TPI 1, or for handling, shipping, installation and bracing of trusses. A seal on this drawing or cover page listing this drawing, indicates acceptance of professional engineering responsibility solely for the design shown. The suitability and use of this drawing for any structure is the responsibility of the Building Designer per ANSI/TPI 1 Sec.2.
For more information see these web sites: Alpine: alpineitw.com; TPI: tpinst.org; SBCA: sbcacomponents.com; ICC: iccsafe.org; AWC: awc.org



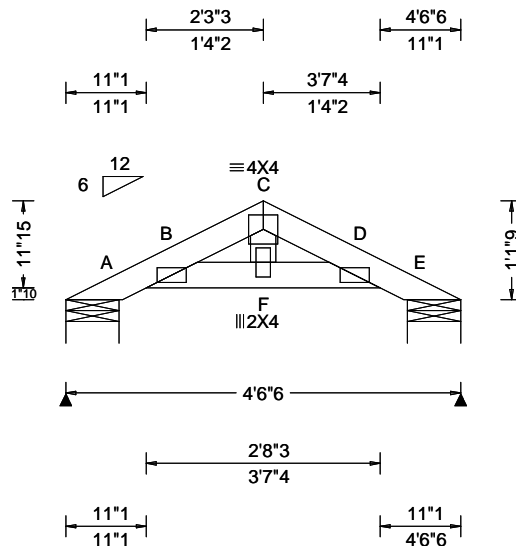

Loading Criteria (psf)	Wind Criteria	Snow Criteria (Pg,Pf in PSF)	Defl/CSI Criteria	▲ Maximum Reactions (lbs)
TCLL: 20.00 TCDL: 10.00 BCLL: 0.00 BCDL: 10.00 Des Ld: 40.00 NCBCLL: 10.00 Soffit: 2.00 Load Duration: 1.25 Spacing: 24.0 "	Wind Std: ASCE 7-10 Speed: 130 mph Enclosure: Closed Risk Category: II EXP: C Kzt: NA Mean Height: 20.74 ft TCDL: 5.0 psf BCDL: 2.0 psf MWFRS Parallel Dist: 0 to h/2 C&C Dist a: 3.00 ft Loc. from endwall: Any GCpi: 0.18 Wind Duration: 1.60	Pg: NA Ct: NA CAT: NA Pf: NA Ce: NA Lu: NA Cs: NA Snow Duration: NA Building Code: FBC 2017 RES TPI Std: 2014 Rep Fac: Yes FT/RT:20(0)/10(0) Plate Type(s): WAVE	PP Deflection in loc L/defl L/# VERT(LL): 0.004 C 999 240 VERT(CL): 0.007 C 999 180 HORZ(LL): 0.002 F - - HORZ(TL): 0.003 F - - Creep Factor: 2.0 Max TC CSI: 0.089 Max BC CSI: 0.038 Max Web CSI: 0.010 VIEW Ver: 19.02.02B.0122.15	Gravity Non-Gravity Loc R+ / R- / Rh / Rw / U / RL A 129 /- /- /112 /38 /43 E 129 /- /- /84 /36 /- Wind reactions based on MWFRS A Brg Width = 7.3 Min Req = 1.5 E Brg Width = 7.3 Min Req = 1.5 Bearings A & E are a rigid surface. Members not listed have forces less than 375#

Lumber

Top chord: 2x4 SP #2;
Bot chord: 2x4 SP #2;
Webs: 2x4 SP #3;

Plating Notes

All plates are 2X4(A1) except as noted.

Wind

Wind loads based on MWFRS with additional C&C member design.
Uplifts based on an elevation at or above 1000 ft.

Additional Notes

Refer to DWG PB160101014 for piggyback details.
The overall height of this truss excluding overhang is 11-1-9.

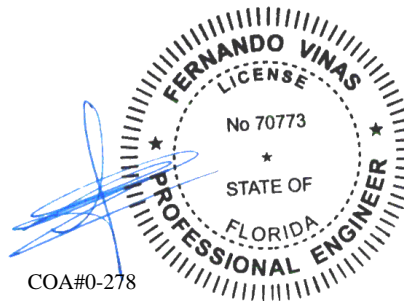

02/28/2022

****WARNING** READ AND FOLLOW ALL NOTES ON THIS DRAWING!**
****IMPORTANT** FURNISH THIS DRAWING TO ALL CONTRACTORS INCLUDING THE INSTALLERS**
Trusses require extreme care in fabricating, handling, shipping, installing and bracing. Refer to and follow the latest edition of BCSI (Building Component Safety Information, by TPI and SBCA) for safety practices prior to performing these functions. Installers shall provide temporary bracing per BCSI. Unless noted otherwise, top chord shall have properly attached structural sheathing and bottom chord shall have a properly attached rigid ceiling. Locations shown for permanent lateral restraint of webs shall have bracing installed per BCSI sections B3, B7, or B10, as applicable. Apply plates to each face of truss and position as shown above and on the Joint Details, unless noted otherwise. Refer to drawings 160A-Z for standard plate positions. Refer to job's General Notes page for additional information.
Alpine, a division of ITW Building Components Group Inc. shall not be responsible for any deviation from this drawing, any failure to build the truss in conformance with ANSI/TPI 1, or for handling, shipping, installation and bracing of trusses. A seal on this drawing or cover page listing this drawing, indicates acceptance of professional engineering responsibility solely for the design shown. The suitability and use of this drawing for any structure is the responsibility of the Building Designer per ANSI/TPI 1 Sec.2.
For more information see these web sites: Alpine: www.alpineitw.com; TPI: www.tpinst.org; SBCA: www.sbcindustry.com; ICC: www.iccsafe.org



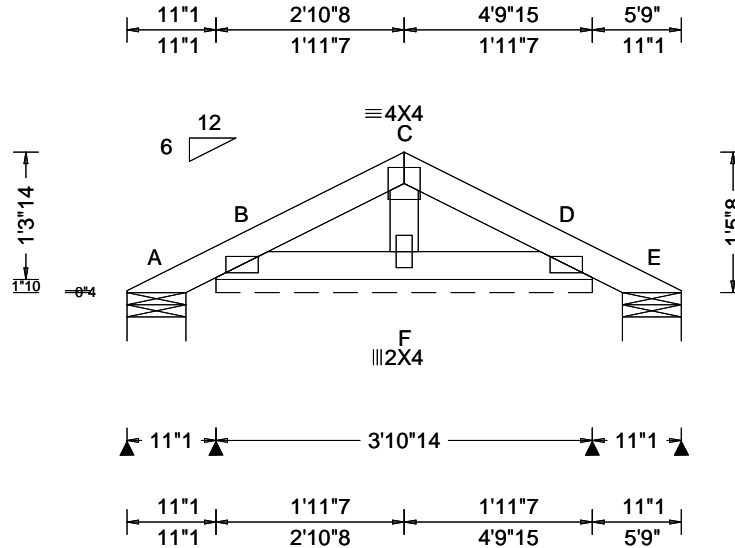

Loading Criteria (psf)	Wind Criteria	Snow Criteria (Pg,Pf in PSF)	Defl/CSI Criteria	▲ Maximum Reactions (lbs), or *=PLF
TCLL: 20.00 TCDL: 10.00 BCLL: 0.00 BCDL: 10.00 Des Ld: 40.00 NCBCLL: 10.00 Soffit: 2.00 Load Duration: 1.25 Spacing: 24.0 "	Wind Std: ASCE 7-10 Speed: 130 mph Enclosure: Closed Risk Category: II EXP: C Kzt: NA Mean Height: 20.74 ft TCDL: 5.0 psf BCDL: 2.0 psf MWFRS Parallel Dist: 0 to h/2 C&C Dist a: 3.00 ft Loc. from endwall: Any GCpi: 0.18 Wind Duration: 1.60	Pg: NA Ct: NA CAT: NA Pf: NA Ce: NA Lu: NA Cs: NA Snow Duration: NA Building Code: FBC 2017 RES TPI Std: 2014 Rep Fac: Yes FT/RT:20(0)/10(0) Plate Type(s): WAVE	PP Deflection in loc L/defl L/# VERT(LL): 0.000 F 999 240 VERT(CL): 0.001 F 999 180 HORZ(LL): 0.000 F - - HORZ(TL): 0.000 F - - Creep Factor: 2.0 Max TC CSI: 0.047 Max BC CSI: 0.022 Max Web CSI: 0.015 VIEW Ver: 19.02.02B.0122.15	Gravity Loc R+ / R- / Rh / Rw / U / RL Non-Gravity A 12 /- /- /24 /13 /33 B* 81 /- /- /54 /33 /- E 12 /- /- /14 /7 /- Wind reactions based on MWFRS A Brg Width = 7.3 Min Req = 1.5 B Brg Width = 46.8 Min Req = - E Brg Width = 7.3 Min Req = 1.5 Bearings A, B, & E are a rigid surface. Members not listed have forces less than 375#

Lumber

Top chord: 2x4 SP #2;
Bot chord: 2x4 SP #2;
Webs: 2x4 SP #3;

Plating Notes

All plates are 2X4(A1) except as noted.

Wind

Wind loads based on MWFRS with additional C&C member design.
Uplifts based on an elevation at or above 1000 ft.

Additional Notes

Refer to DWG PB160101014 for piggyback details.
The overall height of this truss excluding overhang is 1-5-8.

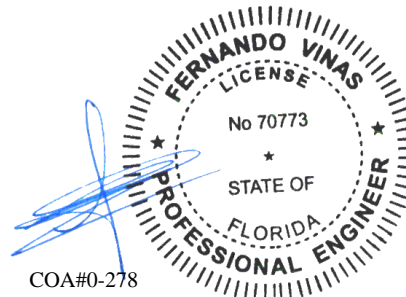

02/28/2022

****WARNING** READ AND FOLLOW ALL NOTES ON THIS DRAWING!**
****IMPORTANT** FURNISH THIS DRAWING TO ALL CONTRACTORS INCLUDING THE INSTALLERS**
Trusses require extreme care in fabricating, handling, shipping, installing and bracing. Refer to and follow the latest edition of BCSI (Building Component Safety Information, by TPI and SBCA) for safety practices prior to performing these functions. Installers shall provide temporary bracing per BCSI. Unless noted otherwise, top chord shall have properly attached structural sheathing and bottom chord shall have a properly attached rigid ceiling. Locations shown for permanent lateral restraint of webs shall have bracing installed per BCSI sections B3, B7, or B10, as applicable. Apply plates to each face of truss and position as shown above and on the Joint Details, unless noted otherwise. Refer to drawings 160A-Z for standard plate positions. Refer to job's General Notes page for additional information.
Alpine, a division of ITW Building Components Group Inc. shall not be responsible for any deviation from this drawing, any failure to build the truss in conformance with ANSI/TPI 1, or for handling, shipping, installation and bracing of trusses. A seal on this drawing or cover page listing this drawing, indicates acceptance of professional engineering responsibility solely for the design shown. The suitability and use of this drawing for any structure is the responsibility of the Building Designer per ANSI/TPI 1 Sec.2.
For more information see these web sites: Alpine: www.alpineitw.com; TPI: www.tpinst.org; SBCA: www.sbcindustry.com; ICC: www.iccsafe.org



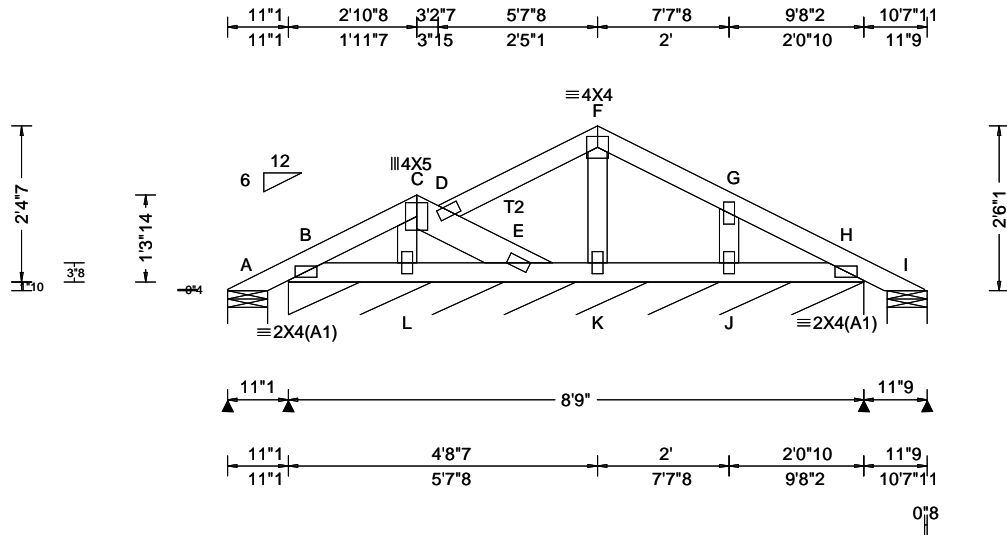

Loading Criteria (psf)	Wind Criteria	Snow Criteria (Pg,Pf in PSF)	Defl/CSI Criteria	▲ Maximum Reactions (lbs), or *=PLF
TCLL: 20.00 TCDL: 10.00 BCLL: 0.00 BCDL: 10.00 Des Ld: 40.00 NCBCLL: 10.00 Soffit: 2.00 Load Duration: 1.25 Spacing: 24.0 *	Wind Std: ASCE 7-10 Speed: 130 mph Enclosure: Closed Risk Category: II EXP: C Kzt: NA Mean Height: 21.26 ft TCDL: 5.0 psf BCDL: 2.0 psf MWFRS Parallel Dist: h/2 to h C&C Dist a: 3.00 ft Loc. from endwall: not in 9.00 ft GCpi: 0.18 Wind Duration: 1.60	Pg: NA Ct: NA CAT: NA Pf: NA Ce: NA Lu: NA Cs: NA Snow Duration: NA Building Code: FBC 2017 RES TPI Std: 2014 Rep Fac: Yes FT/RT:20(0)/10(0) Plate Type(s): WAVE	PP Deflection in loc L/defl L/# VERT(LL): 0.000 L 999 240 VERT(CL): 0.001 L 999 180 HORZ(LL): 0.000 J - - HORZ(TL): 0.001 J - - Creep Factor: 2.0 Max TC CSI: 0.089 Max BC CSI: 0.021 Max Web CSI: 0.034 VIEW Ver: 19.02.02B.0122.15	Gravity Loc R+ / R- / Rh / Rw / U / RL Non-Gravity A 12 /- /- /36 /26 /63 B* 72 /- /- /49 /21 /- I 15 /- /- /15 /5 /- Wind reactions based on MWFRS A Brg Width = 7.3 Min Req = 1.5 B Brg Width = 105 Min Req = - I Brg Width = 7.3 Min Req = 1.5 Bearings A, B, & I are a rigid surface. Members not listed have forces less than 375#

Lumber
Top chord: 2x4 SP #2; T2 2x6 SP 2400f-2.0E;
Bot chord: 2x4 SP #2;
Webs: 2x4 SP #3;

Plating Notes
All plates are 2X4 except as noted.

Wind
Wind loads based on MWFRS with additional C&C member design.
Uplifts based on an elevation at or above 1000 ft.

Additional Notes
Refer to DWG PB160101014 for piggyback details.
The overall height of this truss excluding overhang is 2-6-1.

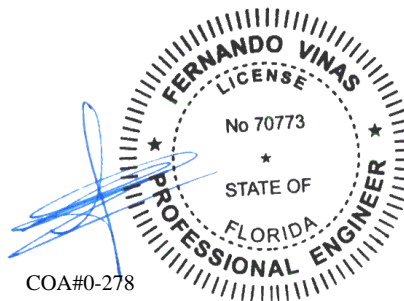

COA#0-278
02/28/2022

****WARNING** READ AND FOLLOW ALL NOTES ON THIS DRAWING!**
****IMPORTANT** FURNISH THIS DRAWING TO ALL CONTRACTORS INCLUDING THE INSTALLERS**
Trusses require extreme care in fabricating, handling, shipping, installing and bracing. Refer to and follow the latest edition of BCSI (Building Component Safety Information, by TPI and SBCA) for safety practices prior to performing these functions. Installers shall provide temporary bracing per BCSI. Unless noted otherwise, top chord shall have properly attached structural sheathing and bottom chord shall have a properly attached rigid ceiling. Locations shown for permanent lateral restraint of webs shall have bracing installed per BCSI sections B3, B7, or B10, as applicable. Apply plates to each face of truss and position as shown above and on the Joint Details, unless noted otherwise. Refer to drawings 160A-Z for standard plate positions. Refer to job's General Notes page for additional information.
Alpine, a division of ITW Building Components Group Inc. shall not be responsible for any deviation from this drawing, any failure to build the truss in conformance with ANSI/TPI 1, or for handling, shipping, installation and bracing of trusses. A seal on this drawing or cover page listing this drawing, indicates acceptance of professional engineering responsibility solely for the design shown. The suitability and use of this drawing for any structure is the responsibility of the Building Designer per ANSI/TPI 1 Sec.2.
For more information see these web sites: Alpine: www.alpineitw.com; TPI: www.tpinst.org; SBCA: www.sbcindustry.com; ICC: www.iccsafe.org



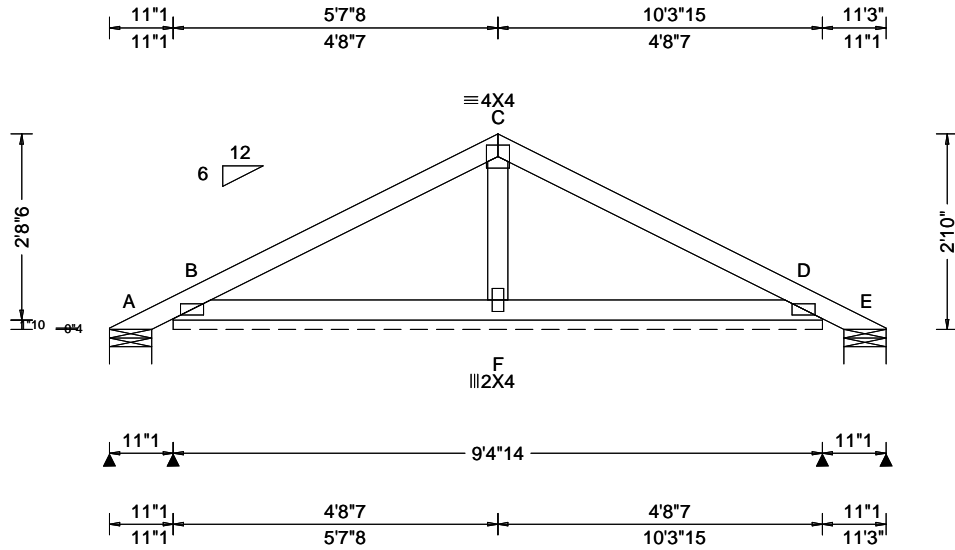

Loading Criteria (psf)	Wind Criteria	Snow Criteria (Pg,Pf in PSF)	Defl/CSI Criteria	▲ Maximum Reactions (lbs), or *=PLF
TCLL: 20.00 TCDL: 10.00 BCLL: 0.00 BCDL: 10.00 Des Ld: 40.00 NCBCLL: 10.00 Soffit: 2.00 Load Duration: 1.25 Spacing: 24.0 "	Wind Std: ASCE 7-10 Speed: 130 mph Enclosure: Closed Risk Category: II EXP: C Kzt: NA Mean Height: 21.43 ft TCDL: 5.0 psf BCDL: 2.0 psf MWFRS Parallel Dist: h/2 to h C&C Dist a: 3.00 ft Loc. from endwall: not in 9.00 ft GCp: 0.18 Wind Duration: 1.60	Pg: NA Ct: NA CAT: NA Pf: NA Ce: NA Lu: NA Cs: NA Snow Duration: NA Building Code: FBC 2017 RES TPI Std: 2014 Rep Fac: Yes FT/RT:20(0)/10(0) Plate Type(s): WAVE	PP Deflection in loc L/defl L/# VERT(LL): 0.003 D 999 240 VERT(CL): 0.005 D 999 180 HORZ(LL): -0.002 D - - HORZ(TL): 0.003 D - - Creep Factor: 2.0 Max TC CSI: 0.236 Max BC CSI: 0.116 Max Web CSI: 0.030 VIEW Ver: 21.01.01A.0521.20	Gravity Loc R+ / R- / Rh / Rw / U / RL Non-Gravity A - /-98 /- /58 /90 /68 B* 95 /- /- /58 /31 /- E - /-98 /- /38 /60 /- Wind reactions based on MWFRS A Brg Wid = 7.3 Min Req = 1.5 B Brg Wid = 112 Min Req = - E Brg Wid = 7.3 Min Req = 1.5 Bearings A, B, & E are a rigid surface. Members not listed have forces less than 375#

Lumber

Top chord: 2x4 SP #2;
Bot chord: 2x4 SP #2;
Webs: 2x4 SP #3;

Plating Notes

All plates are 2X4(A1) except as noted.

Wind

Wind loads based on MWFRS with additional C&C member design.
Uplifts based on an elevation at or above 1000 ft.

Additional Notes

Refer to DWG PB160101014 for piggyback details.
The overall height of this truss excluding overhang is 2-10-0.

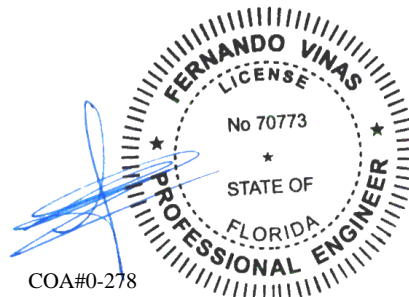

02/28/2022

****WARNING** READ AND FOLLOW ALL NOTES ON THIS DRAWING!**
****IMPORTANT** FURNISH THIS DRAWING TO ALL CONTRACTORS INCLUDING THE INSTALLERS**
Trusses require extreme care in fabricating, handling, shipping, installing and bracing. Refer to and follow the latest edition of BCSI (Building Component Safety Information, by TPI and SBCA) for safety practices prior to performing these functions. Installers shall provide temporary bracing per BCSI. Unless noted otherwise, top chord shall have properly attached structural sheathing and bottom chord shall have a properly attached rigid ceiling. Locations shown for permanent lateral restraint of webs shall have bracing installed per BCSI sections B3, B7, or B10, as applicable. Apply plates to each face of truss and position as shown above and on the Joint Details, unless noted otherwise. Refer to drawings 160A-Z for standard plate positions. Refer to job's General Notes page for additional information.
Alpine, a division of ITW Building Components Group Inc. shall not be responsible for any deviation from this drawing, any failure to build the truss in conformance with ANSI/TPI 1, or for handling, shipping, installation and bracing of trusses. A seal on this drawing or cover page listing this drawing, indicates acceptance of professional engineering responsibility solely for the design shown. The suitability and use of this drawing for any structure is the responsibility of the Building Designer per ANSI/TPI 1 Sec.2.
For more information see these web sites: Alpine: alpineitw.com; TPI: tpinst.org; SBCA: sbcacomponents.com; ICC: iccsafe.org; AWC: awc.org



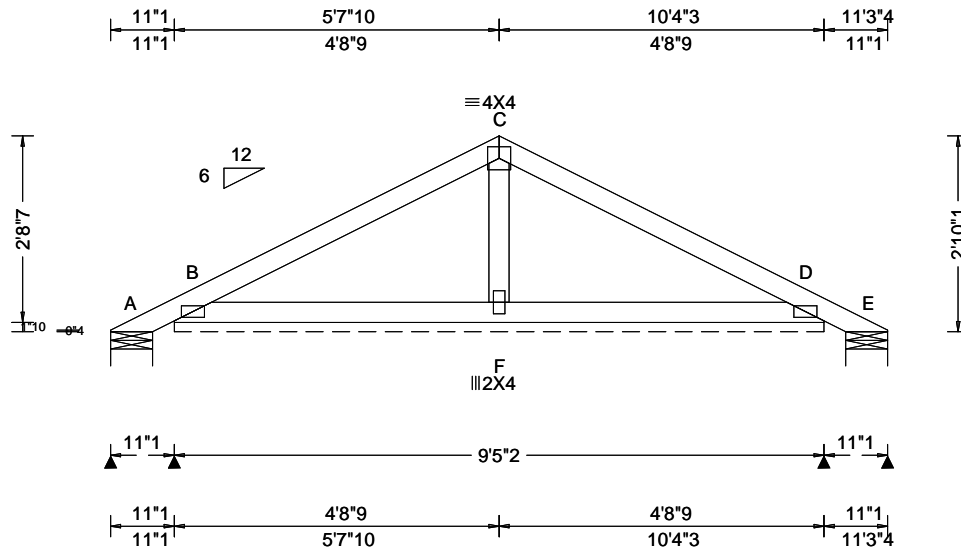

Loading Criteria (psf) TCLL: 20.00 TCDL: 10.00 BCLL: 0.00 BCDL: 10.00 Des Ld: 40.00 NCBCLL: 10.00 Soffit: 2.00 Load Duration: 1.25 Spacing: 24.0 "	Wind Criteria Wind Std: ASCE 7-10 Speed: 130 mph Enclosure: Closed Risk Category: II EXP: C Kzt: NA Mean Height: 21.43 ft TCDL: 5.0 psf BCDL: 2.0 psf MWFRS Parallel Dist: h to 2h C&C Dist a: 3.00 ft Loc. from endwall: not in 9.00 ft GCp: 0.18 Wind Duration: 1.60	Snow Criteria (Pg,Pf in PSF) Pg: NA Ct: NA CAT: NA Pf: NA Ce: NA Lu: NA Cs: NA Snow Duration: NA Building Code: FBC 2017 RES TPI Std: 2014 Rep Fac: Yes FT/RT:20(0)/10(0) Plate Type(s): WAVE	Defl/CSI Criteria PP Deflection in loc L/def L/# VERT(LL): 0.003 D 999 240 VERT(CL): 0.005 D 999 180 HORZ(LL): -0.002 D - - HORZ(TL): 0.003 D - - Creep Factor: 2.0 Max TC CSI: 0.237 Max BC CSI: 0.116 Max Web CSI: 0.030 VIEW Ver: 21.01.01A.0521.20	▲ Maximum Reactions (lbs), or *=PLF Gravity Non-Gravity Loc R+ /R- /Rh /Rw /U /RL A - /-99 /- /58 /90 /68 B* 95 /- /- /58 /19 /- E - /-99 /- /28 /61 /- Wind reactions based on MWFRS A Brg Wid = 7.3 Min Req = 1.5 B Brg Wid = 113 Min Req = - E Brg Wid = 7.3 Min Req = 1.5 Bearings A, B, & E are a rigid surface. Members not listed have forces less than 375#
--	--	---	---	---

Lumber

Top chord: 2x4 SP #2;
Bot chord: 2x4 SP #2;
Webs: 2x4 SP #3;

Plating Notes

All plates are 2X4(A1) except as noted.

Wind

Wind loads based on MWFRS with additional C&C member design.
Uplifts based on an elevation at or above 1000 ft.

Additional Notes

Refer to DWG PB160101014 for piggyback details.
The overall height of this truss excluding overhang is 2-10-1.

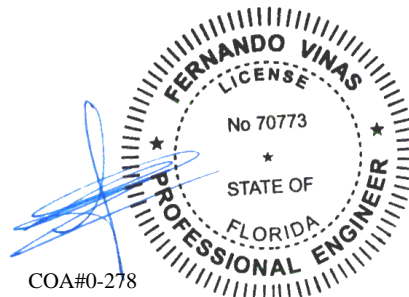

02/28/2022

****WARNING** READ AND FOLLOW ALL NOTES ON THIS DRAWING!**
****IMPORTANT** FURNISH THIS DRAWING TO ALL CONTRACTORS INCLUDING THE INSTALLERS**
Trusses require extreme care in fabricating, handling, shipping, installing and bracing. Refer to and follow the latest edition of BCSI (Building Component Safety Information, by TPI and SBCA) for safety practices prior to performing these functions. Installers shall provide temporary bracing per BCSI. Unless noted otherwise, top chord shall have properly attached structural sheathing and bottom chord shall have a properly attached rigid ceiling. Locations shown for permanent lateral restraint of webs shall have bracing installed per BCSI sections B3, B7, or B10, as applicable. Apply plates to each face of truss and position as shown above and on the Joint Details, unless noted otherwise. Refer to drawings 160A-Z for standard plate positions. Refer to job's General Notes page for additional information.
Alpine, a division of ITW Building Components Group Inc. shall not be responsible for any deviation from this drawing, any failure to build the truss in conformance with ANSI/TPI 1, or for handling, shipping, installation and bracing of trusses. A seal on this drawing or cover page listing this drawing, indicates acceptance of professional engineering responsibility solely for the design shown. The suitability and use of this drawing for any structure is the responsibility of the Building Designer per ANSI/TPI 1 Sec.2.
For more information see these web sites: Alpine: alpineitw.com; TPI: tpinst.org; SBCA: sbccomponents.com; ICC: iccsafe.org; AWC: awc.org



SEQN: 647484 FROM: CDM	GABL Ply: 1 Qty: 1	Job Number: 22-6970 Jordan - Lancaster Model Truss Label: PB06	Cust: R215 JRef: 1Xdd2150013 T50 DrwNo: 059.22.1344.44170 GA / FV 02/28/2022
---------------------------	--------------------------	--	--

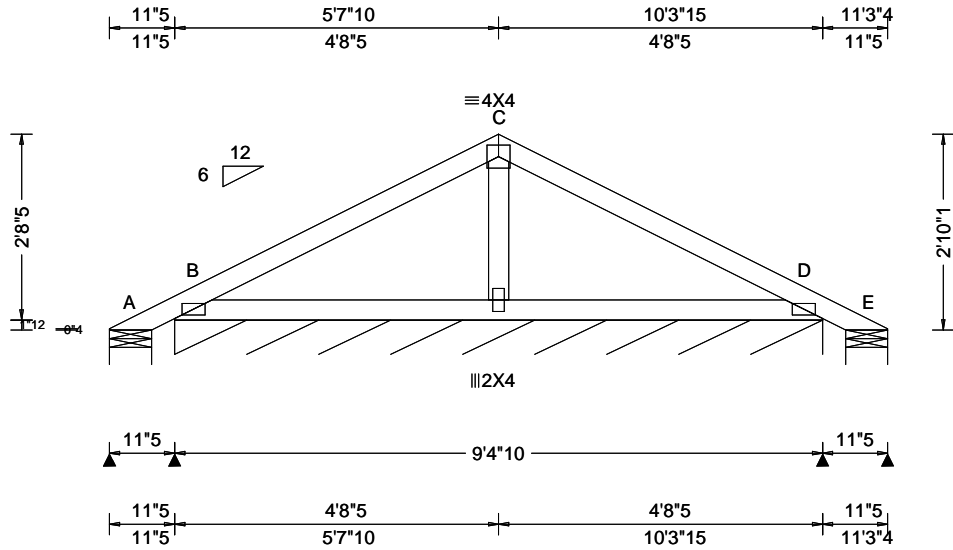

Loading Criteria (psf) TCLL: 20.00 TCDL: 10.00 BCLL: 0.00 BCDL: 10.00 Des Ld: 40.00 NCBCLL: 10.00 Soffit: 2.00 Load Duration: 1.25 Spacing: 24.0 "	Wind Criteria Wind Std: ASCE 7-10 Speed: 130 mph Enclosure: Closed Risk Category: II EXP: C Kzt: NA Mean Height: 16.11 ft TCCL: 5.0 psf BCDL: 5.0 psf MWFRS Parallel Dist: > 2h C&C Dist a: 3.16 ft Loc. from endwall: not in 13.00 ft GCpi: 0.18 Wind Duration: 1.60	Snow Criteria (Pg,Pf in PSF) Pg: NA Ct: NA CAT: NA Pf: NA Ce: NA Lu: NA Cs: NA Snow Duration: NA Building Code: FBC 2017 RES TPI Std: 2014 Rep Fac: Yes FT/RT:20(0)/10(0) Plate Type(s): WAVE	Defl/CSI Criteria PP Deflection in loc L/def L/# VERT(LL): 0.003 D 999 240 VERT(CL): 0.005 D 999 180 HORZ(LL): -0.002 D - - HORZ(TL): 0.003 D - - Creep Factor: 2.0 Max TC CSI: 0.234 Max BC CSI: 0.093 Max Web CSI: 0.030 VIEW Ver: 21.01.01A.0521.20	▲ Maximum Reactions (lbs), or *=PLF Gravity Non-Gravity																								
				<table border="1"> <thead> <tr> <th>Loc</th> <th>R+</th> <th>/R-</th> <th>/Rh</th> <th>/Rw</th> <th>/U</th> <th>/RL</th> </tr> </thead> <tbody> <tr> <td>A</td> <td>-</td> <td>/-88</td> <td>/-</td> <td>/53</td> <td>/92</td> <td>/73</td> </tr> <tr> <td>B*</td> <td>95</td> <td>/-</td> <td>/-</td> <td>/52</td> <td>/1</td> <td>/-</td> </tr> <tr> <td>E</td> <td>-</td> <td>/-88</td> <td>/-</td> <td>/21</td> <td>/60</td> <td>/-</td> </tr> </tbody> </table> Wind reactions based on MWFRS A Brg Wid = 7.3 Min Req = 1.5 B Brg Wid = 112 Min Req = - E Brg Wid = 7.3 Min Req = 1.5 Bearings A, B, & E are a rigid surface. Members not listed have forces less than 375#	Loc	R+	/R-	/Rh	/Rw	/U	/RL	A	-	/-88	/-	/53	/92	/73	B*	95	/-	/-	/52	/1	/-	E	-	/-88
Loc	R+	/R-	/Rh	/Rw	/U	/RL																						
A	-	/-88	/-	/53	/92	/73																						
B*	95	/-	/-	/52	/1	/-																						
E	-	/-88	/-	/21	/60	/-																						

Lumber

Top chord: 2x4 SP #2;
 Bot chord: 2x4 SP #2;
 Webs: 2x4 SP #3;

Plating Notes

All plates are 2X4(A1) except as noted.

Loading

Gable end supports 8" max rake overhang. Top chord must not be cut or notched.

Wind

Wind loads based on MWFRS with additional C&C member design.

Uplifts based on an elevation at or above 1000 ft.

Additional Notes

See DWGS A14030ENC101014 & GBLLETIN0118 for gable wind bracing and other requirements.

Refer to DWG PB160101014 for piggyback details.

The overall height of this truss excluding overhang is 2-10-1.

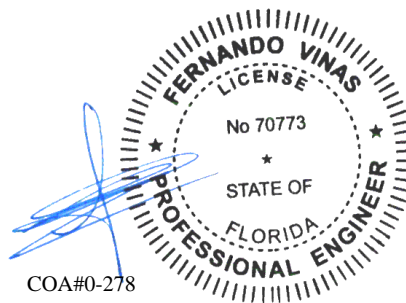

COA#0-278

02/28/2022

****WARNING** READ AND FOLLOW ALL NOTES ON THIS DRAWING!**
****IMPORTANT** FURNISH THIS DRAWING TO ALL CONTRACTORS INCLUDING THE INSTALLERS**

Trusses require extreme care in fabricating, handling, shipping, installing and bracing. Refer to and follow the latest edition of BCSI (Building Component Safety Information, by TPI and SBCA) for safety practices prior to performing these functions. Installers shall provide temporary bracing per BCSI. Unless noted otherwise, top chord shall have properly attached structural sheathing and bottom chord shall have a properly attached rigid ceiling. Locations shown for permanent lateral restraint of webs shall have bracing installed per BCSI sections B3, B7, or B10, as applicable. Apply plates to each face of truss and position as shown above and on the Joint Details, unless noted otherwise. Refer to drawings 160A-Z for standard plate positions. Refer to job's General Notes page for additional information.

Alpine, a division of ITW Building Components Group Inc. shall not be responsible for any deviation from this drawing, any failure to build the truss in conformance with ANSI/TPI 1, or for handling, shipping, installation and bracing of trusses. A seal on this drawing or cover page listing this drawing, indicates acceptance of professional engineering responsibility solely for the design shown. The suitability and use of this drawing for any structure is the responsibility of the Building Designer per ANSI/TPI 1 Sec.2.

For more information see these web sites: Alpine: alpineitw.com; TPI: tpinst.org; SBCA: sbccomponents.com; ICC: iccsafe.org; AWC: awc.org



6750 Forum Drive
 Suite 305
 Orlando FL, 32821

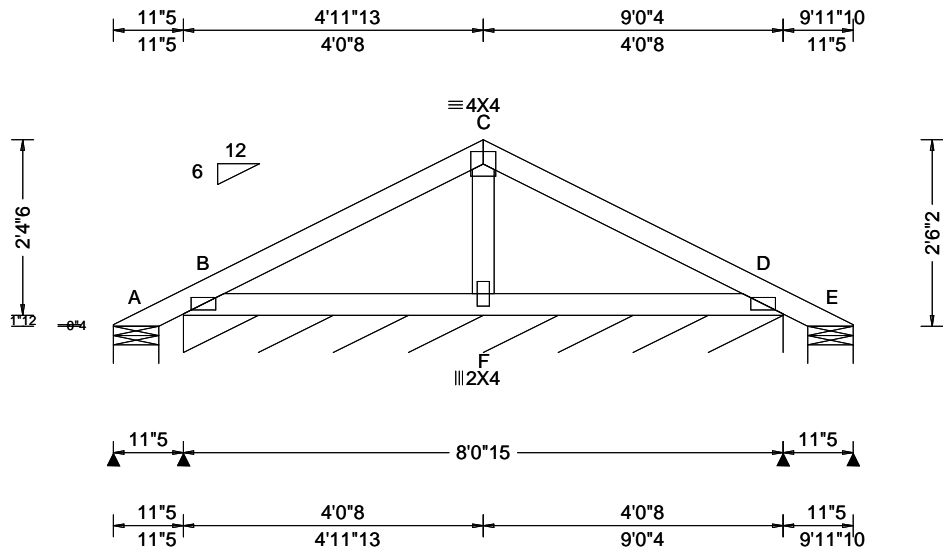

Loading Criteria (psf)	Wind Criteria	Snow Criteria (Pg,Pf in PSF)	Defl/CSI Criteria	▲ Maximum Reactions (lbs), or *=PLF																																		
TCCL: 20.00 TCDL: 10.00 BCLL: 0.00 BCDL: 10.00 Des Ld: 40.00 NCBCLL: 10.00 Soffit: 2.00 Load Duration: 1.25 Spacing: 24.0 "	Wind Std: ASCE 7-10 Speed: 130 mph Enclosure: Closed Risk Category: II EXP: C Kzt: NA Mean Height: 21.27 ft TCDL: 5.0 psf BCDL: 2.0 psf MWFRS Parallel Dist: h to 2h C&C Dist a: 3.00 ft Loc. from endwall: not in 9.00 ft GCcpi: 0.18 Wind Duration: 1.60	Pg: NA Ct: NA CAT: NA Pf: NA Ce: NA Lu: NA Cs: NA Snow Duration: NA Building Code: FBC 2017 RES TPI Std: 2014 Rep Fac: Yes FT/RT:20(0)/10(0) Plate Type(s): WAVE	PP Deflection in loc L/def L/# VERT(LL): 0.002 D 999 240 VERT(CL): 0.004 D 999 180 HORZ(LL): -0.001 D - - HORZ(TL): 0.002 D - - Creep Factor: 2.0 Max TC CSI: 0.168 Max BC CSI: 0.084 Max Web CSI: 0.025 VIEW Ver: 21.01.01A.0521.20	<table border="1" style="width:100%; border-collapse: collapse;"> <thead> <tr> <th rowspan="2">Loc</th> <th colspan="3">Gravity</th> <th colspan="3">Non-Gravity</th> </tr> <tr> <th>R+</th> <th>/R-</th> <th>/Rh</th> <th>/Rw</th> <th>/U</th> <th>/RL</th> </tr> </thead> <tbody> <tr> <td>A</td> <td>-</td> <td>/-57</td> <td>/-</td> <td>/43</td> <td>/58</td> <td>/60</td> </tr> <tr> <td>B*</td> <td>90</td> <td>/-</td> <td>/-</td> <td>/56</td> <td>/17</td> <td>/-</td> </tr> <tr> <td>E</td> <td>-</td> <td>/-57</td> <td>/-</td> <td>/16</td> <td>/32</td> <td>/-</td> </tr> </tbody> </table> Wind reactions based on MWFRS A Brg Wid = 7.3 Min Req = 1.5 B Brg Wid = 96.9 Min Req = - E Brg Wid = 7.3 Min Req = 1.5 Bearings A, B, & E are a rigid surface. Members not listed have forces less than 375#	Loc	Gravity			Non-Gravity			R+	/R-	/Rh	/Rw	/U	/RL	A	-	/-57	/-	/43	/58	/60	B*	90	/-	/-	/56	/17	/-	E	-	/-57	/-	/16	/32	/-
Loc	Gravity			Non-Gravity																																		
	R+	/R-	/Rh	/Rw	/U	/RL																																
A	-	/-57	/-	/43	/58	/60																																
B*	90	/-	/-	/56	/17	/-																																
E	-	/-57	/-	/16	/32	/-																																

Lumber

Top chord: 2x4 SP #2;
 Bot chord: 2x4 SP #2;
 Webs: 2x4 SP #3;

Plating Notes

All plates are 2X4(A1) except as noted.

Wind

Wind loads based on MWFRS with additional C&C member design.
 Uplifts based on an elevation at or above 1000 ft.

Additional Notes

Refer to DWG PB160101014 for piggyback details.
 The overall height of this truss excluding overhang is 2-6-2.

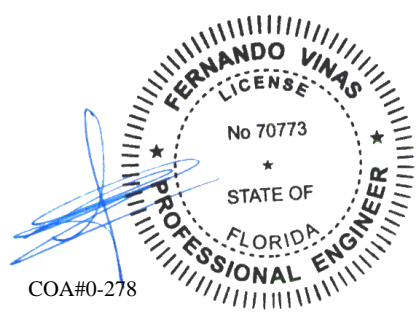

COA#0-278

02/28/2022

****WARNING** READ AND FOLLOW ALL NOTES ON THIS DRAWING!**
****IMPORTANT** FURNISH THIS DRAWING TO ALL CONTRACTORS INCLUDING THE INSTALLERS**
 Trusses require extreme care in fabricating, handling, shipping, installing and bracing. Refer to and follow the latest edition of BCSI (Building Component Safety Information, by TPI and SBCA) for safety practices prior to performing these functions. Installers shall provide temporary bracing per BCSI. Unless noted otherwise, top chord shall have properly attached structural sheathing and bottom chord shall have a properly attached rigid ceiling. Locations shown for permanent lateral restraint of webs shall have bracing installed per BCSI sections B3, B7, or B10, as applicable. Apply plates to each face of truss and position as shown above and on the Joint Details, unless noted otherwise. Refer to drawings 160A-Z for standard plate positions. Refer to job's General Notes page for additional information.
 Alpine, a division of ITW Building Components Group Inc. shall not be responsible for any deviation from this drawing, any failure to build the truss in conformance with ANSI/TPI 1, or for handling, shipping, installation and bracing of trusses. A seal on this drawing or cover page listing this drawing, indicates acceptance of professional engineering responsibility solely for the design shown. The suitability and use of this drawing for any structure is the responsibility of the Building Designer per ANSI/TPI 1 Sec.2.
 For more information see these web sites: Alpine: alpineitw.com; TPI: tpinst.org; SBCA: sbcacomponents.com; ICC: iccsafe.org; AWC: awc.org



Gable Stud Reinforcement Detail

ASCE 7-10: 140 mph Wind Speed, 30' Mean Height, Enclosed, Exposure C, Kzt = 1.00

- Or: 120 mph Wind Speed, 30' Mean Height, Partially Enclosed, Exposure C, Kzt = 1.00
- Or: 120 mph Wind Speed, 30' Mean Height, Enclosed, Exposure D, Kzt = 1.00
- Or: 100 mph wind speed, 30' Mean Height, Partially Enclosed, Exposure D, Kzt = 1.00

Max Gable Vertical Length	2x4 Gable Vertical		Brace Grade	No Braces	(1) 1x4 'L' Brace *		(1) 2x4 'L' Brace *		(2) 2x4 'L' Brace **		(1) 2x6 'L' Brace *		(2) 2x6 'L' Brace **		
	Spacing	Species			Group A	Group B	Group A	Group B	Group A	Group B	Group A	Group B	Group A	Group B	
	24" o.c.	SPF	#1 / #2	HF	#1 / #2	4' 1"	6' 11"	7' 2"	8' 2"	8' 6"	9' 9"	10' 2"	12' 10"	13' 4"	14' 0"
#3					3' 10"	6' 2"	6' 7"	8' 1"	8' 5"	9' 8"	10' 0"	12' 8"	13' 2"	14' 0"	14' 0"
Stud					3' 10"	6' 2"	6' 6"	8' 1"	8' 5"	9' 8"	10' 0"	12' 8"	13' 2"	14' 0"	14' 0"
Standard			3' 10"		5' 3"	5' 7"	7' 0"	7' 6"	9' 6"	10' 0"	11' 0"	11' 10"	14' 0"	14' 0"	
#1			4' 2"		7' 0"	7' 3"	8' 3"	8' 7"	9' 10"	10' 3"	13' 0"	13' 6"	14' 0"	14' 0"	
#2			4' 1"		6' 11"	7' 2"	8' 2"	8' 6"	9' 9"	10' 2"	12' 10"	13' 4"	14' 0"	14' 0"	
SP		#3	DFL	#3	4' 0"	5' 7"	5' 11"	7' 5"	7' 11"	9' 8"	10' 1"	11' 7"	12' 5"	14' 0"	14' 0"
				Stud	4' 0"	5' 7"	5' 11"	7' 5"	7' 11"	9' 8"	10' 1"	11' 7"	12' 5"	14' 0"	14' 0"
				Standard	3' 9"	4' 11"	5' 13"	6' 6"	7' 0"	8' 10"	9' 6"	10' 3"	11' 0"	13' 11"	14' 0"
		#1 / #2		4' 8"	7' 11"	8' 3"	9' 4"	9' 9"	11' 2"	11' 7"	14' 0"	14' 0"	14' 0"	14' 0"	
		#3		4' 5"	7' 6"	8' 3"	9' 3"	9' 7"	11' 0"	11' 6"	14' 0"	14' 0"	14' 0"	14' 0"	
		Stud		4' 5"	7' 6"	8' 0"	9' 3"	9' 7"	11' 0"	11' 6"	14' 0"	14' 0"	14' 0"	14' 0"	
16" o.c.	SPF	#3	HF	#3	4' 5"	6' 5"	6' 10"	8' 7"	9' 2"	11' 0"	11' 6"	13' 6"	14' 0"	14' 0"	14' 0"
				Stud	4' 5"	6' 5"	6' 10"	8' 7"	9' 2"	11' 0"	11' 6"	13' 6"	14' 0"	14' 0"	14' 0"
				Standard	4' 5"	6' 5"	6' 10"	8' 7"	9' 2"	11' 0"	11' 6"	13' 6"	14' 0"	14' 0"	14' 0"
		#1		4' 10"	8' 0"	8' 4"	9' 6"	9' 10"	11' 3"	11' 9"	14' 0"	14' 0"	14' 0"	14' 0"	
		#2		4' 8"	7' 11"	8' 3"	9' 4"	9' 9"	11' 2"	11' 7"	14' 0"	14' 0"	14' 0"	14' 0"	
		#3		4' 7"	6' 10"	7' 3"	9' 1"	9' 8"	11' 1"	11' 6"	14' 0"	14' 0"	14' 0"	14' 0"	
	SP	Stud	DFL	Stud	4' 7"	6' 10"	7' 3"	9' 1"	9' 8"	11' 1"	11' 6"	14' 0"	14' 0"	14' 0"	14' 0"
				Standard	4' 5"	6' 0"	6' 5"	8' 0"	8' 7"	10' 10"	11' 6"	12' 7"	13' 15"	14' 0"	14' 0"
				#1 / #2	5' 2"	8' 9"	9' 1"	10' 4"	10' 9"	11' 2"	12' 9"	14' 0"	14' 0"	14' 0"	14' 0"
		#3		4' 10"	8' 7"	8' 11"	10' 2"	10' 7"	12' 2"	12' 8"	14' 0"	14' 0"	14' 0"	14' 0"	
		Stud		4' 10"	8' 7"	8' 11"	10' 2"	10' 7"	12' 2"	12' 8"	14' 0"	14' 0"	14' 0"	14' 0"	
		Standard		4' 10"	7' 5"	7' 11"	9' 11"	10' 7"	12' 2"	12' 8"	14' 0"	14' 0"	14' 0"	14' 0"	
SP	#1	DFL	#1	5' 4"	8' 10"	9' 2"	10' 5"	10' 10"	12' 5"	12' 11"	14' 0"	14' 0"	14' 0"	14' 0"	
			#2	5' 2"	8' 9"	9' 1"	10' 4"	10' 9"	12' 3"	12' 9"	14' 0"	14' 0"	14' 0"	14' 0"	
			#3	5' 0"	7' 10"	8' 4"	10' 3"	10' 8"	12' 2"	12' 8"	14' 0"	14' 0"	14' 0"	14' 0"	
	Stud		5' 0"	7' 10"	8' 4"	10' 3"	10' 8"	12' 2"	12' 8"	14' 0"	14' 0"	14' 0"	14' 0"		
	Standard		4' 10"	6' 11"	7' 4"	9' 3"	9' 10"	12' 2"	12' 8"	14' 0"	14' 0"	14' 0"	14' 0"		

Bracing Group Species and Grades:

Group A:			
Spruce-Pine-Fir		Hem-Fir	
#1 / #2	Standard	#2	Stud
#3	Stud	#3	Standard
Douglas Fir-Larch		Southern Pine***	
#3		#3	
Stud		Stud	
Standard		Standard	

Group B:	
Hem-Fir	
#1 & Btr	
#1	
Douglas Fir-Larch	
#1	
#2	
Southern Pine***	
#1	
#2	

1x4 Braces shall be SRB (Stress-Rated Board).
 ***For 1x4 So. Pine use only Industrial 55 or Industrial 45 Stress-Rated Boards. Group B values may be used with these grades.

Gable Truss Detail Notes:
 Wind Load deflection criterion is L/240.
 Provide uplift connections for 100 plf over continuous bearing (5 psf TC Dead Load).
 Gable end supports load from 4' 0" outlookers with 2' 0" overhang, or 12' plywood overhang.

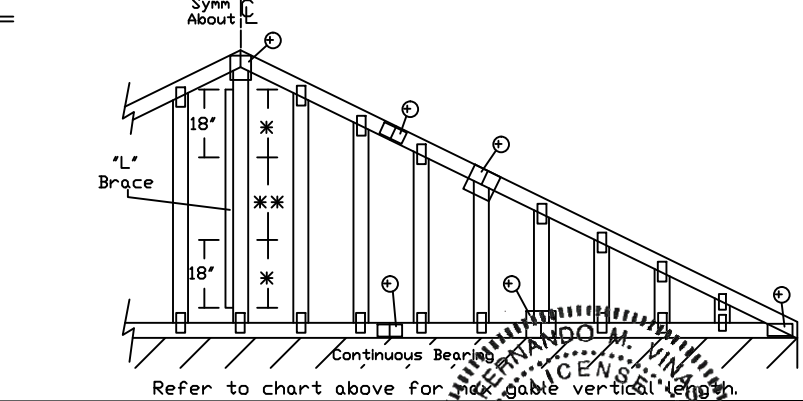
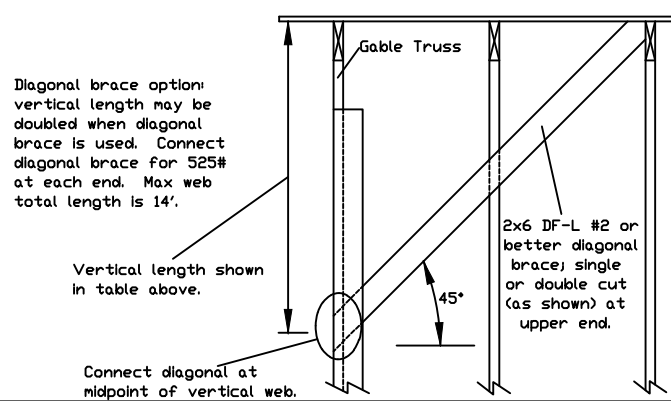

Attach 'L' braces with 10d (0.128"x3.0" min) nails.
 * For (1) 'L' brace: space nails at 2' o.c. in 18' end zones and 4' o.c. between zones.
 ** For (2) 'L' braces: space nails at 3' o.c. in 18' end zones and 6' o.c. between zones.

'L' bracing must be a minimum of 80% of web member length.

Gable Vertical Plate Sizes	
Vertical Length	No Splice
Less than 4' 0"	2X4
Greater than 4' 0", but less than 11' 6"	3X4
Greater than 11' 6"	4X4

+ Refer to common truss design for peak, splice, and heel plates.

Refer to the Building Designer for conditions not addressed by this detail.

514 Earth City Expressway
Suite 242
Earth City, MO 63045

WARNING: READ AND FOLLOW ALL NOTES ON THIS DRAWING
IMPORTANT: FURNISH THIS DRAWING TO ALL CONTRACTORS INCLUDING THE INSTALLERS.

Trusses require extreme care in fabricating, handling, shipping, installing and bracing. Refer to and follow the latest edition of BCSI (Building Component Safety Information, by TPI and SBCA) for safety practices prior to performing these functions. Installers shall provide temporary bracing per BCSI. Unless noted otherwise, top chord shall have properly attached structural sheathing and bottom chord shall have a properly attached rigid ceiling. Locations shown for permanent lateral restraint of webs shall have bracing installed per BCSI sections B3, B7 or B10, as applicable. Apply plates to each face of truss and position as shown above and on the Joint Details, unless noted otherwise. Refer to drawings 160A-Z for standard plate positions.

Alpine, a division of ITW Building Components Group Inc. shall not be responsible for any deviation from this drawing, any failure to build the truss in conformance with ANSI/TPI 1, or for handling, shipping, installation & bracing of trusses.

A seal on this drawing or cover page listing this drawing, indicates acceptance of professional engineering responsibility solely for the design shown. The suitability and use of this drawing for any structure is the responsibility of the Building Designer per ANSI/TPI 1 Sec.2.

For more information see this Job's general notes page and these web sites:
 ALPINE: www.alpineitw.com TPI: www.tpinst.org SBCA: www.sbcacomponents.com ICC: www.iccsafe.org

No 70773

STATE OF FLORIDA
PROFESSIONAL ENGINEER

COA#0-278

REF	ASCE7-10-GAB14030
DATE	10/01/14
DRWG	A14030ENC101014
MAX. TOT. LD. 60 PSF	
MAX. SPACING 24.0"	

CLR Reinforcing Member Substitution

This detail is to be used when a Continuous Lateral Restraint (CLR) is specified on a truss design but an alternative web reinforcement method is desired.

Notes:

This detail is only applicable for changing the specified CLR shown on single ply sealed designs to T-reinforcement or L-reinforcement or scab reinforcement.

Alternative reinforcement specified in chart below may be conservative. For minimum alternative reinforcement, re-run design with appropriate reinforcement type.

Use scabs instead of L- or T- reinforcement on webs with intersecting truss joints, such as K-web joints, that may interfere with proper application along the narrow face of the web.

Web Member Size	Specified CLR Restraint	Alternative Reinforcement T- or L- Reinf.	Scab Reinf.
2x3 or 2x4	1 row	2x4	1-2x4
2x3 or 2x4	2 rows	2x6	2-2x4
2x6	1 row	2x4	1-2x6
2x6	2 rows	2x6	2-2x4(*)
2x8	1 row	2x6	1-2x8
2x8	2 rows	2x6	2-2x6(*)

T-reinforcement, L-reinforcement, or scab reinforcement to be same species and grade or better than web member unless specified otherwise on Engineer's sealed design.

(*) Center scab on wide face of web. Apply (1) scab to each face of web.

T-Reinforcement or L-Reinforcement:

Apply to either side of web narrow face. Attach with 10d (0.128"x3.0",min) nails at 6" o.c. Reinforcing member is a minimum 80% of web member length.

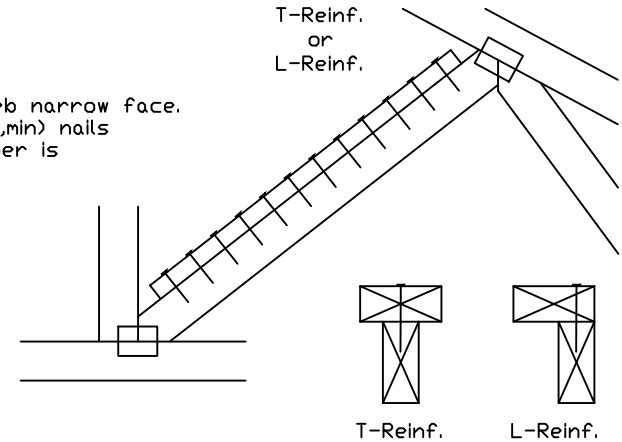

Scab Reinforcement:

Apply scab(s) to wide face of web. No more than (1) scab per face. Attach with 10d (0.128"x3.0",min) nails at 6" o.c. Reinforcing member is a minimum 80% of web member length.

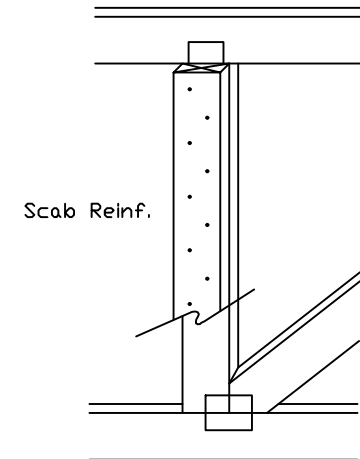

514 Earth City Expressway
Suite 242
Earth City, MO 63045

WARNING: READ AND FOLLOW ALL NOTES ON THIS DRAWING
IMPORTANT: FURNISH THIS DRAWING TO ALL CONTRACTORS INCLUDING THE INSTALLERS.

Trusses require extreme care in fabricating, handling, shipping, installing and bracing. Refer to and follow the latest edition of BCSI (Building Component Safety Information, by TPI and SBCA) for safety practices prior to performing these functions. Installers shall provide temporary bracing per BCSI. Unless noted otherwise, top chord shall have properly attached structural sheathing and bottom chord shall have a properly attached rigid ceiling. Locations shown for permanent lateral restraint of webs shall have bracing installed per BCSI sections B3, B7 or B10, as applicable. Apply plates to each face of truss and position as shown above and on the Joint Details, unless noted otherwise. Refer to drawings 150A-Z for standard plate positions.

Alpine, a division of ITW Building Components Group Inc. shall not be responsible for any deviation from this drawing, any failure to build the truss in conformance with ANSI/TPI 1, or for handling, shipping, installation & bracing of trusses.

A seal on this drawing or cover page listing this drawing, indicates acceptance of professional engineering responsibility solely for the design shown. The suitability and use of this drawing for any structure is the responsibility of the Building Designer per ANSI/TPI 1 Sec.2.

For more information see this Job's general notes page and these web sites:
ALPINE: www.alpineitw.com; TPI: www.tpinst.org; SBCA: www.sbcacomponents.com; ICC: www.iccsafe.org

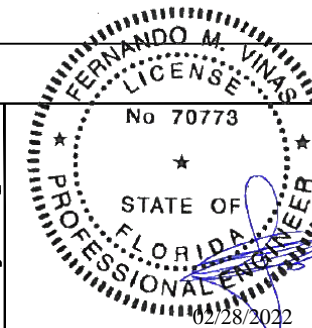

COA#0-278

TC LL	PSF	REF CLR Subst.
TC DL	PSF	DATE 01/02/19
BC DL	PSF	DRWG BRCLBSUB0119
BC LL	PSF	
TOT. LD.	PSF	
DUR. FAC.		
SPACING		

NAIL SPACING DETAIL

MINIMUM SPACING FOR SINGLE BLOCK IS SHOWN. DOUBLE NAIL SPACINGS AND STAGGER NAILING FOR TWO BLOCKS. GREATER SPACING MAY BE REQUIRED TO AVOID SPLITTING.

BLOCK LOCATION, SIZE, LENGTH, GRADE AND TOTAL NUMBER AND TYPE OF NAILS ARE TO BE SPECIFIED ON SEALED DESIGN REFERENCING THIS DETAIL.

LOAD PERPENDICULAR TO GRAIN

- A - EDGE DISTANCE AND SPACING BETWEEN STAGGERED ROWS OF NAILS (6 NAIL DIAMETERS)
- B - SPACING OF NAILS IN A ROW (12 NAIL DIAMETERS)
- C - END DISTANCE (15 NAIL DIAMETERS)

LOAD PARALLEL TO GRAIN

- A - EDGE DISTANCE (6 NAIL DIAMETERS)
- C - SPACING OF NAILS IN A ROW AND END DISTANCE (15 NAIL DIAMETERS)
- D - SPACING BETWEEN STAGGERED ROWS OF NAILS (7 1/2 NAIL DIAMETERS)

IF NAIL HOLES ARE PREBORED, SOME SPACING MAY BE REDUCED BY THE AMOUNTS GIVEN BELOW:

- * SPACING MAY BE REDUCED BY 50%
- ** SPACING MAY BE REDUCED BY 33%

MINIMUM NAIL SPACING DISTANCES

NAIL TYPE	DISTANCES			
	A	B*	C**	D
8d BOX (0.113"X 2.5",MIN)	3/4"	1 3/8"	1 3/4"	7/8"
10d BOX (0.128"X 3",MIN)	7/8"	1 5/8"	2"	1"
12d BOX (0.128"X 3.25",MIN)	7/8"	1 5/8"	2"	1"
16d BOX (0.135"X 3.5",MIN)	7/8"	1 5/8"	2 1/8"	1 1/8"
20d BOX (0.148"X 4",MIN)	1"	1 7/8"	2 1/4"	1 1/8"
8d COMMON (0.131"X 2.5",MIN)	7/8"	1 5/8"	2"	1"
10d COMMON (0.148"X 3",MIN)	1"	1 7/8"	2 1/4"	1 1/8"
12d COMMON (0.148"X 3.25",MIN)	1"	1 7/8"	2 1/4"	1 1/8"
16d COMMON (0.162"X 3.5",MIN)	1"	2"	2 1/2"	1 1/4"
GUN (0.120"X 2.5",MIN)	3/4"	1 1/2"	1 7/8"	1"
GUN (0.131"X 2.5",MIN)	7/8"	1 5/8"	2"	1"
GUN (0.120"X 3",MIN)	3/4"	1 1/2"	1 7/8"	1"
GUN (0.131"X 3",MIN)	7/8"	1 5/8"	2"	1"

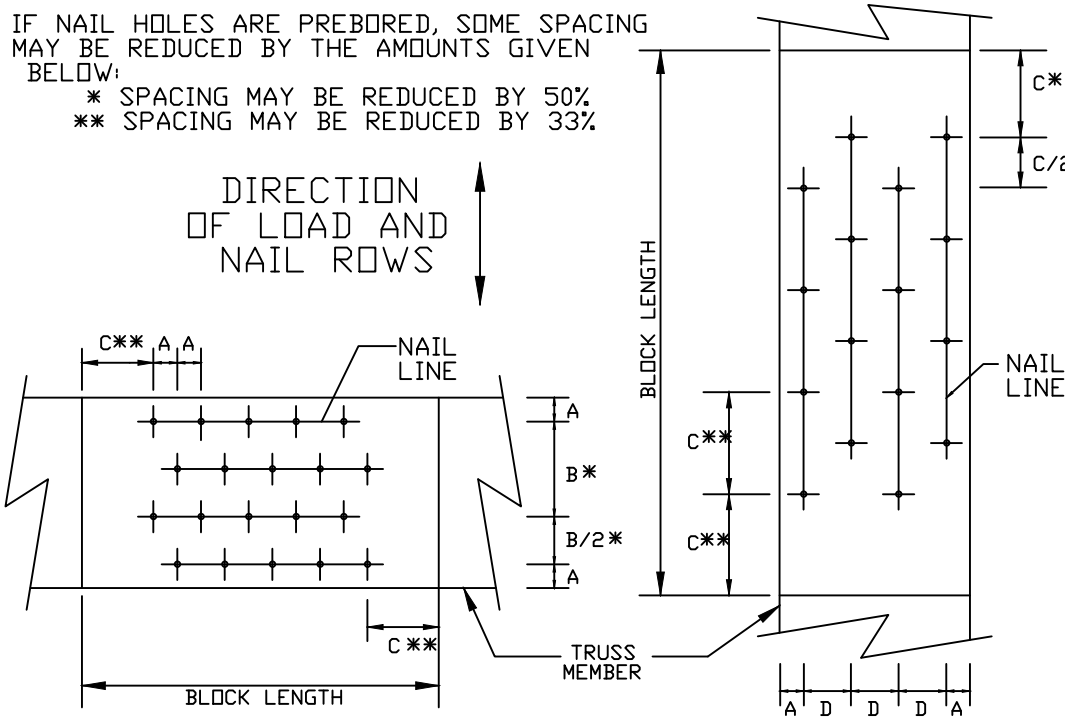

LOAD APPLIED PERPENDICULAR TO GRAIN

LOAD APPLIED PARALLEL TO GRAIN

WARNING: READ AND FOLLOW ALL NOTES ON THIS DRAWING. IMPORTANT: FURNISH THIS DRAWING TO ALL CONTRACTORS INCLUDING THE INSTALLERS.

Trusses require extreme care in fabricating, handling, shipping, installing and bracing. Refer to and follow the latest edition of BCSI (Building Component Safety Information, by TPI and SBCA) for safety practices prior to performing these functions. Installers shall provide temporary bracing per BCSI. Unless noted otherwise, top chord shall have properly attached structural sheathing and bottom chord shall have a properly attached rigid ceiling. Locations shown for permanent lateral restraint of webs shall have bracing installed per BCSI sections B3, B7 or B10, as applicable. Apply plates to each face of truss and position as shown above and on the Joint Details, unless noted otherwise. Refer to drawings 160A-Z for standard plate positions.

Alpine, a division of ITW Building Components Group Inc. shall not be responsible for any deviation from this drawing, any failure to build the truss in conformance with ANSI/TPI 1, or for handling, shipping, installation & bracing of trusses.

A seal on this drawing or cover page listing this drawing, indicates acceptance of professional engineering responsibility solely for the design shown. The suitability and use of this drawing for any structure is the responsibility of the Building Designer per ANSI/TPI 1 Sec.2.

For more information see this Job's general notes page and these web sites:
ALPINE: www.alpineitw.com; TPI: www.tpinst.org; SBCA: www.sbcacomponents.com; ICC: www.iccsafe.org

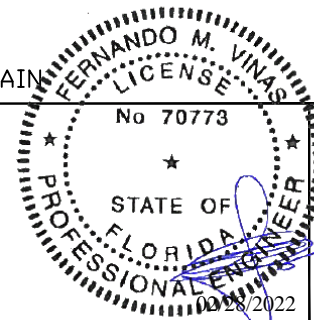

COA#0-278

REF NAIL SPACE

DATE 10/01/14

DRWG CNNAILSP1014



514 Earth City Expressway
Suite 242
Earth City, MO 63045

Gable Detail For Let-in Verticals

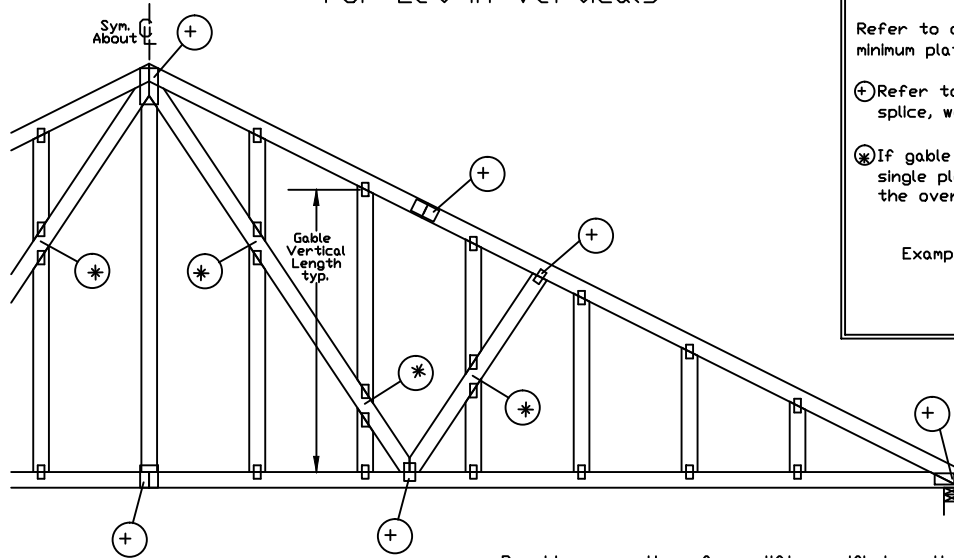

Gable Truss Plate Sizes

Refer to appropriate Alpine gable detail for minimum plate sizes for vertical studs.

- ⊕ Refer to Engineered truss design for peak, splice, web, and heel plates.
- ⊗ If gable vertical plates overlap, use a single plate that covers the total area of the overlapped plates to span the web.

Example:

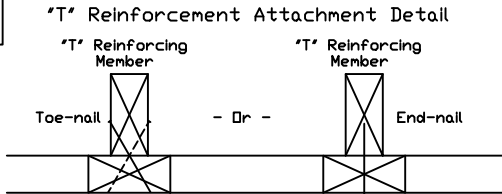

Provide connections for uplift specified on the engineered truss design.

Attach each 'T' reinforcing member with
End Driven Nails:
 10d Common (0.148"x 3",min) Nails at 4' o.c. plus
 (4) nails in the top and bottom chords.

Toenailed Nails:
 10d Common (0.148"x3",min) Toenails at 4' o.c. plus
 (4) toenails in the top and bottom chords.

This detail to be used with the appropriate Alpine gable detail for ASCE wind load.

- ASCE 7-05 Gable Detail Drawings
 A13015051014, A12015051014, A11015051014, A10015051014, A14015051014,
 A13030051014, A12030051014, A11030051014, A10030051014, A14030051014
- ASCE 7-10 & ASCE 7-16 Gable Detail Drawings
 A11515ENC100118, A12015ENC100118, A14015ENC100118, A16015ENC100118,
 A18015ENC100118, A20015ENC100118, A20015END100118, A20015PED100118,
 A11530ENC100118, A12030ENC100118, A14030ENC100118, A16030ENC100118,
 A18030ENC100118, A20030ENC100118, A20030END100118, A20030PED100118,
 S11515ENC100118, S12015ENC100118, S14015ENC100118, S16015ENC100118,
 S18015ENC100118, S20015ENC100118, S20015END100118, S20015PED100118,
 S11530ENC100118, S12030ENC100118, S14030ENC100118, S16030ENC100118,
 S18030ENC100118, S20030ENC100118, S20030END100118, S20030PED100118

See appropriate Alpine gable detail for maximum unreinforced gable vertical length.

To convert from 'L' to 'T' reinforcing members, multiply 'T' increase by length (based on appropriate Alpine gable detail).

Maximum allowable 'T' reinforced gable vertical length is 14' from top to bottom chord.

'T' reinforcing member material must match size, specie, and grade of the 'L' reinforcing member.

Web Length Increase w/ 'T' Brace

'T' Reinf. Mbr. Size	'T' Increase
2x4	30 %
2x6	20 %

Example:
 ASCE 7-10 Wind Speed = 120 mph
 Mean Roof Height = 30 ft, Kzt = 1.00
 Gable Vertical = 24' o.c. SP #3
 'T' Reinforcing Member Size = 2x4
 'T' Brace Increase (From Above) = 30% = 1.30
 (1) 2x4 'L' Brace Length = 8' 7"
 Maximum 'T' Reinforced Gable Vertical Length
 1.30 x 8' 7" = 11' 2"

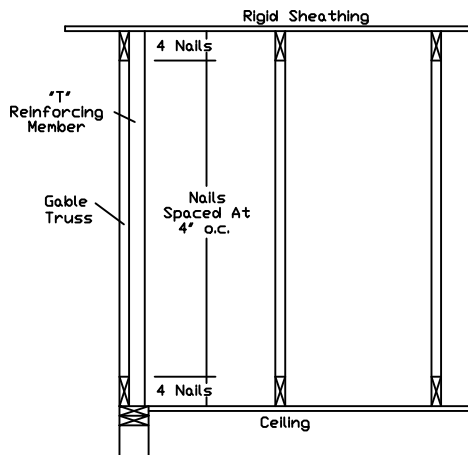

WARNING: READ AND FOLLOW ALL NOTES ON THIS DRAWING
IMPORTANT: FURNISH THIS DRAWING TO ALL CONTRACTORS INCLUDING THE INSTALLERS.

Trusses require extreme care in fabricating, handling, shipping, installing and bracing. Refer to and follow the latest edition of BCSI (Building Component Safety Information, by TPI and SBCA) for safety practices prior to performing these functions. Installers shall provide temporary bracing per BCSI. Unless noted otherwise, top chord shall have properly attached structural sheathing and bottom chord shall have a properly attached rigid ceiling. Locations shown for permanent lateral restraint of webs of truss and position as shown above and on the Joint Details, unless noted otherwise. Refer to drawings 160A-Z for standard plate positions.

Alpine, a division of ITW Building Components Group Inc. shall not be responsible for any deviation from this drawing, any failure to build the truss in conformance with ANSI/TPI 1, or for handling, shipping, installation & bracing of trusses.

A seal on this drawing or cover page listing this drawing, indicates acceptance of professional engineering responsibility solely for the design shown. The suitability and use of this drawing for any structure is the responsibility of the Building Designer per ANSI/TPI 1 Sec.2.

For more information see this Job's general notes page and these web sites:
 ALPINE: www.alpineitw.com; TPI: www.tpinet.org; SBCA: www.sbcacomponents.com; ICC: www.iccsafe.org



514 Earth City Expressway
 Suite 242
 Earth City, MO 63045

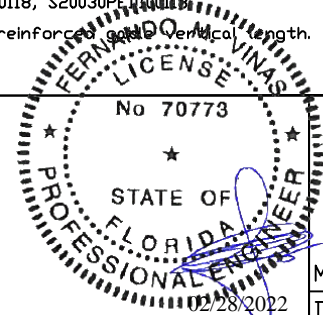

COA#0-278

REF LET-IN VERT
 DATE 01/02/2018
 DRWG GBLLETIN0118

MAX. TOT. LD. 60 PSF
 DUR. FAC. ANY
 MAX. SPACING 24.0"

Piggyback Detail - ASCE 7-10: 160 mph, 30' Mean Height, Enclosed, Exposure C, Kzt=1.00

160 mph Wind, 30.00 ft Mean Hgt, ASCE 7-10, Enclosed Bldg. located anywhere in roof, Exp C, Wind DL= 5.0 psf (min), Kzt=1.0.
 Or 140 mph wind, 30.00 ft Mean Hgt, ASCE 7-10, Enclosed Bldg. located anywhere in roof, Exp D, wind DL= 5.0 psf (min), Kzt=1.0.

Note: Top chords of trusses supporting piggyback cap trusses must be adequately braced by sheathing or purlins. The building Engineer of Record shall provide diagonal bracing or any other suitable anchorage to permanently restrain purlins, and lateral bracing for out of plane loads over gable ends.

Maximum truss spacing is 24' o.c. detail is not applicable if cap supports additional loads such as cupola, steeple, chimney or drag strut loads.

** Refer to Engineer's sealed truss design drawing for piggyback and base truss specifications.

Detail A : Purlin Spacing = 24" o.c. or less

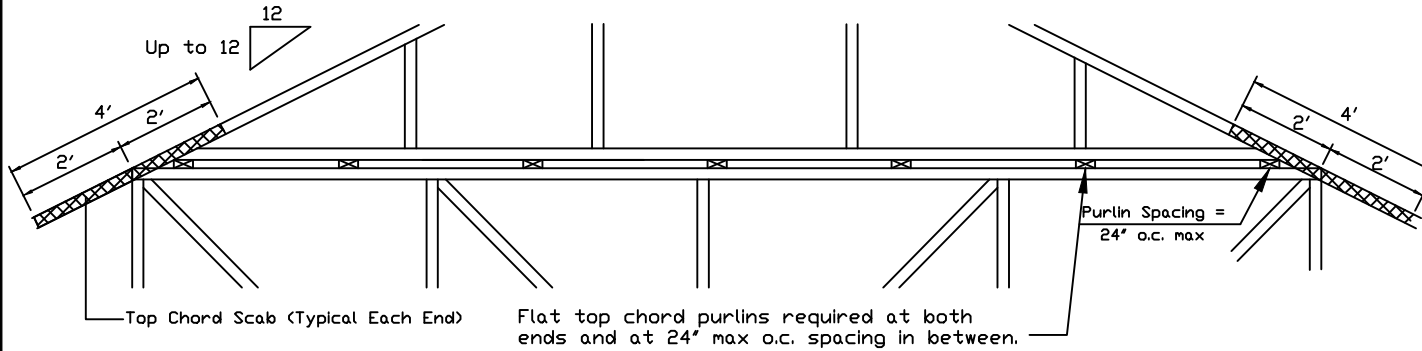

Piggyback cap truss slant nailed to all top chord purlin bracing with (2) 16d box nails (0.135"x3.5") and secure top chord with 2x4 #3 grade scab (1 side only at each end) attached with 2 rows of 10d box nails (0.128"x3") at 4' o.c.

Attach purlin bracing to the flat top chord using (2) 16d box nails (0.135"x3.5").

The top chord #3 grade 2x4 scab may be replaced with either of the following: (1) 3X8 Trulox plate attached with (8) 0.120"x1.375" nails, (4) into cap TC & (4) into base truss TC or (1) 28PB wave piggyback plate plated to the piggyback truss TC and attached to the base truss TC with (4) 0.120"x1.375" nails. Note: Nailing thru holes of wave plate is acceptable.

Detail B : Purlin Spacing > 24" o.c.

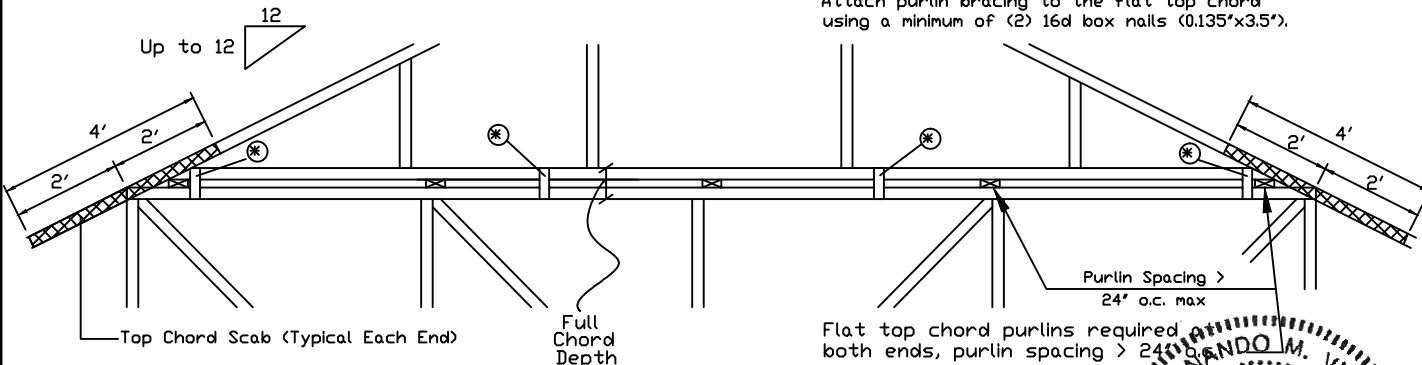

Piggyback cap truss slant nailed to all top chord purlin bracing with (2) 16d box nails (0.135"x3.5") and secure top chord with 2x4 #3 grade scab (1 side only at each end) attached with 2 rows of 10d box nails (0.128"x3") at 4' o.c.

Attach purlin bracing to the flat top chord using a minimum of (2) 16d box nails (0.135"x3.5").

Note: If purlins or sheathing are not specified on the flat top of the base truss, purlins must be installed at 24' o.c. max. and use Detail A.

* In addition, provide connection with one of the following methods:

- Trulox**
Use 3X8 Trulox plates for 2x4 chord member, and 3X10 Trulox plates for 2x6 and larger chord members. Attach to each face @ 8' o.c. with (4) 0.120"x1.375" nails into cap bottom chord and (4) in base truss top chord. Trulox plates may be staggered 4' o.c. front to back faces.
- APA Rated Gusset**
8"x8"x7/16" (min) APA rated sheathing gussets (each face). Attach @ 8' o.c. with (8) 6d common (0.113"x2") nails per gusset, (4) in cap bottom chord and (4) in base truss top chord. Gussets may be staggered 4' o.c. front to back faces.
- 2x4 Vertical Scabs**
2x4 SPF #2, full chord depth scabs (each face). Attach @ 8' o.c. with (6) 10d box nails (0.128"x3") per scab, (3) in cap bottom chord and (3) in base truss top chord. Scabs may be staggered 4' o.c. front to back faces.
- 28PB Wave Piggyback Plate**
One 28PB wave piggyback plate to each face @ 8' o.c. Attach teeth to piggyback at time of fabrication. Attach to supporting truss with (4) 0.120"x1.375" nails per face per ply. Piggyback plates may be staggered 4' o.c. front to back faces.



WARNING: READ AND FOLLOW ALL NOTES ON THIS DRAWING. IMPORTANT: FURNISH THIS DRAWING TO ALL CONTRACTORS INCLUDING THE INSTALLERS.

Trusses require extreme care in fabricating, handling, shipping, installing and bracing. Refer to and follow the latest edition of BCSI (Building Component Safety Information, by TPI and SBCA) for safety practices prior to performing these functions. Installers shall provide temporary bracing per BCSI. Unless noted otherwise, top chord shall have properly attached structural sheathing and bottom chord shall have a properly attached rigid ceiling. Locations shown for permanent lateral restraint of webs shall have bracing installed per BCSI sections B3, B7 or B10, as applicable. Apply plates to each face of truss and position as shown above and on the Joint Details, unless noted otherwise. Refer to drawings 160A-Z for standard plate positions.

Alpine, a division of ITW Building Components Group Inc. shall not be responsible for any deviation from this drawing, any failure to build the truss in conformance with ANSI/TPI 1, or for handling, shipping, installation & bracing of trusses.

A seal on this drawing or cover page listing this drawing, indicates acceptance of professional engineering responsibility solely for the design shown. The suitability and use of this drawing for any structure is the responsibility of the Building Designer per ANSI/TPI 1 Sec.2.

For more information see this Job's general notes page and these web sites:
 ALPINE: www.alpineitw.com; TPI: www.tpinst.org; SBCA: www.sbcacomponents.com; ICC: www.iccsafe.org

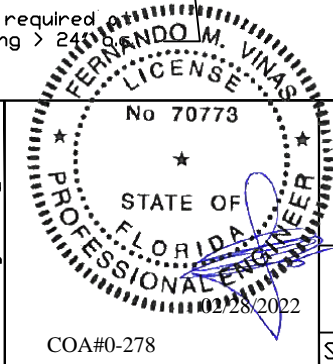

REF	PIGGYBACK
DATE	10/01/14
DRWG	PB160101014
SPACING	24.0"

Valley Detail - ASCE 7-10: 160 mph, 30' Mean Height, Enclosed, Exp. C, Kzt=1.00

Top Chord 2x4 SP #2N, SPF #1/#2, DF-L #2 or better.
 Bot Chord 2x4 SP #2N or SPF #1/#2 or better.
 Webs 2x4 SP #3, SPF #1/#2, DF-L #2 or better.

** Attach each valley to every supporting truss with:
 (2) 16d box (0.135" x 3.5") nails toe-nailed for
 ASCE 7-10 160 mph. 30' Mean Height, Enclosed
 Building, Exp. C, Wind TC DL=5 psf, Kzt = 1.00
 Or
 ASCE 7-10 140 mph. 30' Mean Height, Enclosed
 Building, Exp. D, Wind TC DL=5 psf, Kzt = 1.00

Bottom chord may be square or pitched cut
 as shown.

Valleys short enough to be cut as solid triangular
 members from a single 2x6, or larger as required,
 shall be permitted in lieu of fabricating from
 separate 2x4 members.

All plates shown are ITW BCG Wave Plates.

Unless specified otherwise on engineer's sealed design, for vertical
 valley webs taller than 7-9" apply 2x4 "T" reinforcement, 80% length of
 web, same species and grade or better, attached with 10d box
 (0.128" x 3.0") nails at 6" o.c. In lieu of "T" reinforcement, 2x4 Continuous
 Lateral Restraint applied at mid-length of web is permitted with diagonal
 bracing as shown in DRWG BRCLBANC1014.

Top chord of truss beneath valley set must be braced with:
 properly attached, rated sheathing applied prior to valley truss
 installation.

- Or
- Purlins at 24" o.c. or as otherwise specified on engineer's sealed design
- Or
- By valley trusses used in lieu of purlin spacing as specified on
 Engineer's sealed design.

*** Note that the purlin spacing for bracing the top chord of the truss
 beneath the valley is measured along the slope of the top chord.

++ Larger spans may be built as long as the vertical height does
 not exceed 14'-0".

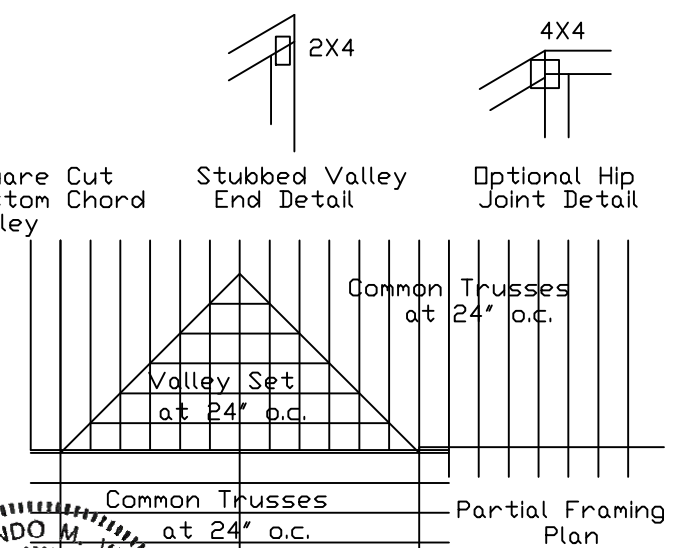
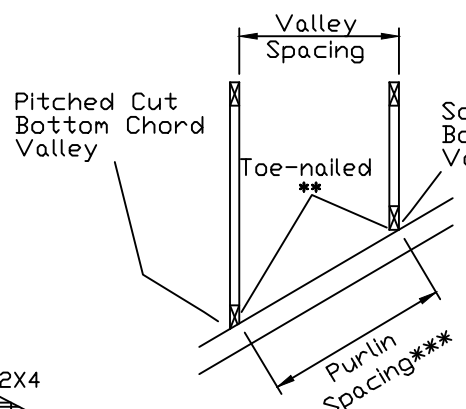
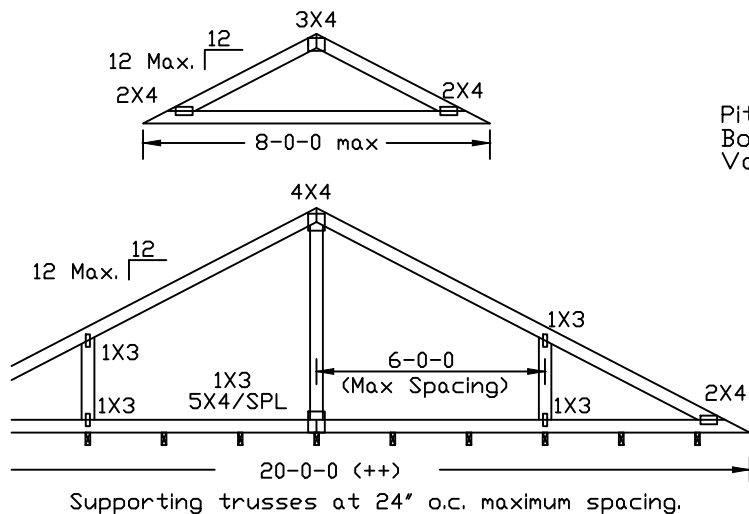

WARNING: READ AND FOLLOW ALL NOTES ON THIS DRAWING
IMPORTANT: FURNISH THIS DRAWING TO ALL CONTRACTORS INCLUDING THE INSTALLERS.
 Trusses require extreme care in fabricating, handling, shipping, installing and bracing. Refer to and follow the latest edition of BCSI (Building Component Safety Information, by TPI and SBCA) for safety practices prior to performing these functions. Installers shall provide temporary bracing per BCSI. Unless noted otherwise, top chord shall have properly attached structural sheathing and bottom chord shall have a properly attached rigid ceiling. Locations shown for permanent lateral restraint of webs shall have bracing installed per BCSI sections B3, B7 or B10, as applicable. Apply plates to each face of truss and position as shown above and on the Joint Details, unless noted otherwise. Refer to drawings 160A-Z for standard plate positions.
 Alpine, a division of ITW Building Components Group Inc. shall not be responsible for any deviation from this drawing, any failure to build the truss in conformance with ANSI/TPI 1, or for handling, shipping, installation & bracing of trusses.
 A seal on this drawing or cover page listing this drawing, indicates acceptance of professional engineering responsibility solely for the design shown. The suitability and use of this drawing for any structure is the responsibility of the Building Designer per ANSI/TPI 1 Sec.2.
 For more information see this Job's general notes page and these web sites:
 ALPINE: www.alpineitw.com; TPI: www.tpinst.org; SBCA: www.sbcacomponents.com; ICC: www.iccsafe.org

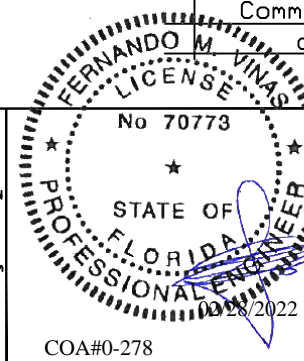

TC LL	30	30	40PSF	REF	VALLEY DETAIL
TC DL	20	15	7 PSF	DATE	10/01/2014
BC DL	10	10	10 PSF	DRWG	VAL160101014
BC LL	0	0	0 PSF		
TOT. LD.	60	55	57PSF		
DUR.FAC.	1.25/1.33	1.15	1.15		
SPACING	24.0"				