

COLUMBIA COUNTY

Property Appraiser

Parcel 11-4S-16-02911-329

Owners

HUBBARD GENE R
HUBBARD DENISE A
P O BOX 70
DIMOCK, PA 18816

[GSA GIS](#) [Pictometry](#)

Parcel Summary

Location	162 SW LUCILE CT
Use Code	0100: SINGLE FAMILY
Tax District	2: COUNTY
Acreage	.5100
Section	11
Township	4S
Range	16
Subdivision	DIST 3

Legal Description

LOT 29 MAY-FAIR S/D UNIT 3.

WD 1087-180, WD 1224-2662, WD 1359-2253,



Working Values

	2026
Total Building	\$230,122
Total Extra Features	\$4,284
Total Market Land	\$35,000
Total Ag Land	\$0
Total Market	\$269,406
Total Assessed	\$269,406
Total Exempt	\$0
Total Taxable	\$269,406
SOH Diff	\$0

Value History

	2025	2024	2023	2022	2021	2020
Total Building	\$232,798	\$220,754	\$204,123	\$186,970	\$159,435	\$147,372
Total Extra Features	\$4,284	\$4,284	\$4,284	\$4,284	\$4,284	\$4,284
Total Market Land	\$35,000	\$30,000	\$28,000	\$22,000	\$18,000	\$18,000
Total Ag Land	\$0	\$0	\$0	\$0	\$0	\$0
Total Market	\$272,082	\$255,038	\$236,407	\$213,254	\$181,719	\$169,656
Total Assessed	\$266,055	\$241,868	\$219,880	\$199,891	\$181,719	\$169,656
Total Exempt	\$0	\$0	\$0	\$0	\$0	\$0
Total Taxable	\$266,055	\$241,868	\$219,880	\$199,891	\$181,719	\$169,656
SOH Diff	\$6,027	\$13,170	\$16,527	\$13,363	\$0	\$0

Document/Transfer/Sales History

Instrument / Official Record	Date	Q/U	Reason	Type	V/I	Sale Price	Ownership
WD 1359/2253	2018-05-11	Q	01	WARRANTY DEED	Improved	\$190,000	Grantor: STEVEN L & TRACY S MCREYNOLDS Grantee: GENE R & DENISE A HUBBARD (H/W)
WD 1224/2662	2011-11-14	Q	01	WARRANTY DEED	Improved	\$170,000	Grantor: STANLEY CRAWFORD CONSTRUCTION INC Grantee: STEVEN L & TRACY S MCREYNOLDS
WD 1087/0180	2006-06-14	Q		WARRANTY DEED	Vacant	\$62,000	Grantor: PETER W GIEBEIG Grantee: STANLEY CRAWFORD CONSTRUCTION INC

Buildings

Building # 1, Section # 1, 145771, SFR

Type	Models	Heated Sq Ft	Repl Cost New	YrBlt	Year Eff	Gross Area	Other % Dpr	Normal % Dpr	% Cond	Value
0100	01	1662	\$267,584	2011	2011	2,394	0.00%	14.00%	86.00%	\$230,122

Structural Elements

Type	Description	Code	Details
EW	Exterior Wall	32	HARDIE BRD
RS	Roof Structure	08	IRREGULAR
RC	Roof Cover	03	COMP SHNGL
IW	Interior Wall	05	DRYWALL
IF	Interior Flooring	13	LAM/VNLPLK
IF	Interior Flooring	14	CARPET
AC	Air Conditioning	03	CENTRAL
HT	Heating Type	04	AIR DUCTED
BDR	Bedrooms	3.00	
BTH	Bathrooms	2.00	
FR	Frame	02	WOOD FRAME
STR	Stories	1.	1.
AR	Architectural Type	05	CONV

Sub Areas

Type	Gross Area	Percent of Base	Adjusted Area
<u>BAS</u>	1,662	100%	1,662
<u>FGR</u>	506	55%	278
<u>FOP</u>	56	30%	17
<u>FSP</u>	170	40%	68

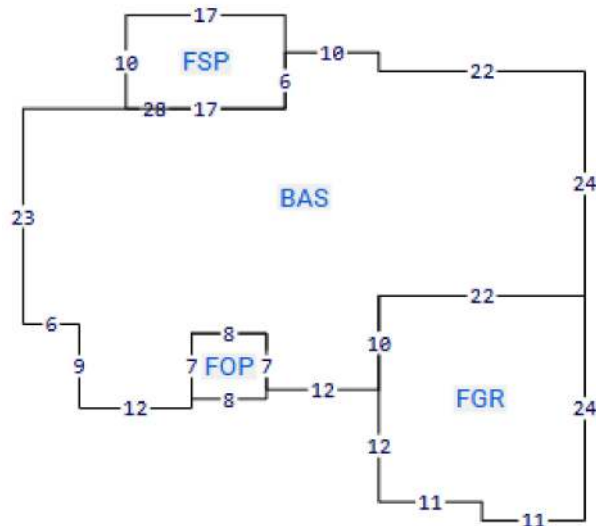

Extra Features

Code	Description	Length	Width	Units	Unit Price	AYB	% Good Condition	Final Value
0166	CONC,PAVMT			1742.00	\$2.00	2011	100%	\$3,484
0120	CLFENCE 4			1.00	\$0.00	2014	100%	\$800

Land Lines

Code	Description	Zone	Front	Depth	Units	Rate/Unit	Acreage	Total Adj	Value
0100	SFR	<u>RSF-1</u>	.00	.00	1.00	\$35,000.00/ <u>LT</u>	0.51	1.00	\$35,000

Personal Property

None

Permits

Date	Permit	Type	Status	Description
Oct 25, 2011	29626	SFR	COMPLETED	SFR

TRIM Notices

2025
2024
2023

Disclaimer

All parcel data on this page is for use by the Columbia County Assessor for assessment purposes only. The summary data on this page may not be a complete representation of the parcel or of the improvements thereon. Building information, including unit counts and number of permitted units, should be verified with the appropriate building and planning agencies. Zoning information should be verified with the appropriate planning agency. All parcels are reappraised each year. This is a true and accurate copy of the records of the Columbia County Assessor's Office as of April 02, 2026.

