

STRUCTURAL DESIGN

PARTIALLY ENCLOSED (UTILITY) BUILDING EXPOSURE B

MAXIMUM 30'-0" WIDE X 20'-0" EAVE HEIGHT- BOX EAVE
FRAME AND BOW FRAME

29 July 2021

Revision 3

M&A Project No. 16154S/17300S/20352S

Prepared for:

Tubular Building Systems, LLC
631 SE Industrial Circle
Lake City, Florida 32025

Prepared by:

Moore and Associates Engineering and Consulting, Inc.
1009 East Avenue
North Augusta, SC 29841

401 S. Main Street, Suite 200
Mount Airy, NC 27030



Wayne
S Moore

Digitally signed
by Wayne S
Moore
Date: 2021.10.21
08:33:08 -04'00'



This item has been electronically signed and sealed by Wayne S. Moore, PE. using a Digital Signature and date.

Printed copies of this document are not considered signed and sealed and the signature must be verified on any electronic copies.



This item has been electronically signed and sealed by Wayne S. Moore, PE. using a Digital Signature and date.

Printed copies of this document are not considered signed and sealed and the signature must be verified on any electronic copies.

MOORE AND ASSOCIATES ENGINEERING AND CONSULTING, INC.	DRAWN BY: JG		TUBULAR BUILDING SYSTEMS 30'-0"x20'-0" UTILITY BUILDING EXP. B PE SEAL COVER SHEET	
	CHECKED BY: PDH			
THIS DOCUMENT IS THE PROPERTY OF MOORE AND ASSOCIATES ENGINEERING AND CONSULTING. THE UNAUTHORIZED REPRODUCTION, COPYING, OR OTHERWISE USE OF THIS DOCUMENT IS STRICTLY PROHIBITED AND ANY INFRINGEMENT THEREUPON MAY BE SUBJECT TO LEGAL ACTION.	PROJECT MGR: WSM	DATE: 7-29-21	SCALE: NTS	JOB NO: 16154S/ 17300S/20352S
	CLIENT: TBS	SHT. 1	DWG. NO: SK-2	REV: 3

DRAWING INDEX

SHEET 1	PE SEAL COVER SHEET
SHEET 2	DRAWING INDEX
SHEET 3	INSTALLATION NOTES AND SPECIFICATIONS
SHEET 4	TYPICAL SIDE AND END ELEVATIONS
SHEET 5	TYPICAL RAFTER COLUMN END AND SIDE FRAMING SECTIONS (BOX EAVE RAFTER)
SHEET 5A	TYPICAL RAFTER COLUMN END AND SIDE FRAMING SECTIONS (BOX EAVE RAFTER)
SHEET 5B	TYPICAL RAFTER COLUMN END AND SIDE FRAMING SECTIONS (BOX EAVE RAFTER)
SHEET 6	TYPICAL RAFTER COLUMN CONNECTION DETAILS (LACED COLUMN)
SHEET 6A	TYPICAL RAFTER COLUMN CONNECTION DETAILS (DOUBLE COLUMN)
SHEET 6B	TYPICAL RAFTER COLUMN CONNECTION DETAILS (SINGLE COLUMN)
SHEET 7	TYPICAL RAFTER COLUMN END AND SIDE FRAMING SECTIONS (BOW RAFTER)
SHEET 7A	TYPICAL RAFTER COLUMN END AND SIDE FRAMING SECTIONS (BOW RAFTER)
SHEET 8	TYPICAL RAFTER COLUMN CONNECTION DETAILS (DOUBLE COLUMN)
SHEET 8A	TYPICAL RAFTER COLUMN CONNECTION DETAILS (SINGLE COLUMN)
SHEET 9	BASE RAIL ANCHORAGE OPTIONS FOR LOW AND HIGH WIND SPEED
SHEET 9A	OPTIONAL FOUNDATION ANCHORAGE FOR LOW AND HIGH WIND SPEED
SHEET 9B	BASE RAIL ANCHORAGE OPTION
SHEET 9C	BASE RAIL ANCHORAGE OPTIONS
SHEET 10	BOX EAVE RAFTER END WALL AND SIDE WALL OPENINGS
SHEET 11	BOW RAFTER END WALL AND SIDE WALL OPENINGS
SHEET 12	CONNECTION DETAILS
SHEET 13	CONNECTION DETAILS
SHEET 14	BOX EAVE RAFTER LEAN-TO OPTIONS
SHEET 14A	BOX EAVE RAFTER LEAN-TO OPTIONS
SHEET 15	BOW RAFTER LEAN-TO OPTIONS
SHEET 16	VERTICAL ROOF/SIDING OPTION
SHEET 17	OPTIONAL DOOR HEADER
SHEET 18	FLOOD VENT DETAIL
SHEET 19	STAND-ALONE STEM WALL DETAIL
SHEET 20	VERTICAL SLIDING WINDOW DETAIL
SHEET 21	STRIP FOOTING OPTION



This item has been electronically signed and sealed by Wayne S. Moore, PE. using a Digital Signature and date.

Printed copies of this document are not considered signed and sealed and the signature must be verified on any electronic copies.

**MOORE AND ASSOCIATES
ENGINEERING AND CONSULTING, INC.**

DRAWN BY: JG

CHECKED BY: PDH

PROJECT MGR: WSM

CLIENT: TBS

**TUBULAR BUILDING SYSTEMS
631 SE INDUSTRIAL CIRCLE
LAKE CITY, FLORIDA 32025
30'-0"x20'-0" UTILITY BUILDING EXP. B**

DATE: 7-29-21

SHT. 2

SCALE: NTS

DWG. NO: SK-2

**JOB NO: 16154S/
17300S/20352S**

REV: 3

THIS DOCUMENT IS THE PROPERTY OF MOORE AND ASSOCIATES ENGINEERING AND CONSULTING. THE UNAUTHORIZED REPRODUCTION, COPYING, OR OTHERWISE USE OF THIS DOCUMENT IS STRICTLY PROHIBITED AND ANY INFRINGEMENT THEREUPON MAY BE SUBJECT TO LEGAL ACTION.

INSTALLATION NOTES AND SPECIFICATIONS

- 1 DESIGN IS FOR A MAXIMUM 30'-0" WIDE x 20'-0" EAVE HEIGHT PARTIALLY ENCLOSED UTILITY STRUCTURES
- 2 DESIGN WAS DONE IN ACCORDANCE WITH THE 2020 FLORIDA BUILDING CODE (FBC) 7TH EDITION, 2012 INTERNATIONAL BUILDING CODE (IBC), 2015 IBC, AND 2018 IBC
- 3 DESIGN LOADS ARE AS FOLLOWS
 - A) DEAD LOAD = 15 PSF
 - B) LIVE LOAD = 12 PSF
 - C) GROUND SNOW LOAD = 10 PSF
- 4 LOW ULTIMATE WIND SPEED 105 TO 140 MPH (NOMINAL WIND SPEED 81 TO 108 MPH); MAXIMUM RAFTER/POST AND END POST SPACING = 5.0 FEET
- 5 HIGH ULTIMATE WIND SPEED 141 TO 170 MPH (NOMINAL WIND SPEED 109 TO 132 MPH); MAXIMUM RAFTER/POST AND END POST SPACING = 4.0 FEET
- 6 END WALL COLUMNS (POSTS) AND SIDE WALL COLUMNS ARE EQUIVALENT IN SIZE AND SPACING (UNLESS NOTED OTHERWISE)
- 7 RISK CATEGORY I
- 8 WIND EXPOSURE CATEGORY B
- 9 SPECIFICATIONS APPLICABLE TO 29 GAUGE METAL PANELS FASTENED DIRECTLY TO 2 1/2" x 2 1/2" - 14 GAUGE TUBE STEEL (TS) FRAMING MEMBERS FOR VERTICAL PANELS, 29 GAUGE METAL PANELS SHALL BE FASTENED TO 18 GAUGE HAT CHANNELS (UNLESS OTHERWISE NOTED)
- 10 AVERAGE FASTENER SPACING ON-CENTERS ALONG RAFTERS OR PURLINS, AND POSTS, INTERIOR = 9" OR END = 6" (MAX)
- 11 FASTENERS CONSIST OF #12-14x3/4" SELF-DRILLING FASTENER (SDF), USE CONTROL SEAL WASHER WITH EXTERIOR FASTENERS SPECIFICATIONS APPLICABLE ONLY FOR MEAN ROOF HEIGHT OF 20 FEET OR LESS, AND ROOF SLOPES OF 14' (3:12 PITCH) OR LESS SPACING REQUIREMENTS FOR OTHER ROOF HEIGHTS AND/OR SLOPES MAY VARY ROOF SLOPES LESS THAN 3:12 REQUIRE USE OF JOINT SEALANT
- 12 STANDARD ANCHORS SHALL BE INSTALLED THROUGH BASE RAIL WITHIN 6" OF EACH COLUMN
- 13 STANDARD GROUND ANCHORS (SOIL NAILS) CONSIST OF #4 REBAR W/WELDED NUT x 30" LONG IN SUITABLE SOIL CONDITIONS MAY BE USED FOR LOW (< 108 MPH NOMINAL) WIND SPEEDS ONLY OPTIONAL ANCHORAGE MAY BE USED IN SUITABLE SOILS AND MUST BE USED IN UNSUITABLE SOILS AS NOTED COORDINATE WITH LOCAL CODES/ORDINANCES REGARDING MINIMUM LENGTH FOR FROST DEPTH PROTECTION
- 14 WIND FORCES GOVERN OVER SEISMIC FORCES SEISMIC PARAMETERS ANALYZED ARE:
 - SOIL SITE CLASS = D
 - RISK CATEGORY I
 - R = 3.25 I_E = 1.0
 - S_{DS} = 1.522 g V = C_SW
 - S_{DI} = 0.839 g



This item has been electronically signed and sealed by Wayne S. Moore, PE. using a Digital Signature and date.

Printed copies of this document are not considered signed and sealed and the signature must be verified on any electronic copies.

MOORE AND ASSOCIATES ENGINEERING AND CONSULTING, INC.	DRAWN BY: JG	TUBULAR BUILDING SYSTEMS 631 SE INDUSTRIAL CIRCLE LAKE CITY, FLORIDA 32025 30'-0"x20'-0" UTILITY BUILDING EXP. B		
	CHECKED BY: PDH			
THIS DOCUMENT IS THE PROPERTY OF MOORE AND ASSOCIATES ENGINEERING AND CONSULTING. THE UNAUTHORIZED REPRODUCTION, COPYING, OR OTHERWISE USE OF THIS DOCUMENT IS STRICTLY PROHIBITED AND ANY INFRINGEMENT THEREUPON MAY BE SUBJECT TO LEGAL ACTION.	PROJECT MGR: WSM	DATE: 7-29-21	SCALE: NTS	JOB NO: 16154S/ 17300S/20352S
	CLIENT: TBS	SHT. 3	DWG. NO: SK-2	REV: 3

BOX EAVE FRAME RAFTER ENCLOSED BUILDING

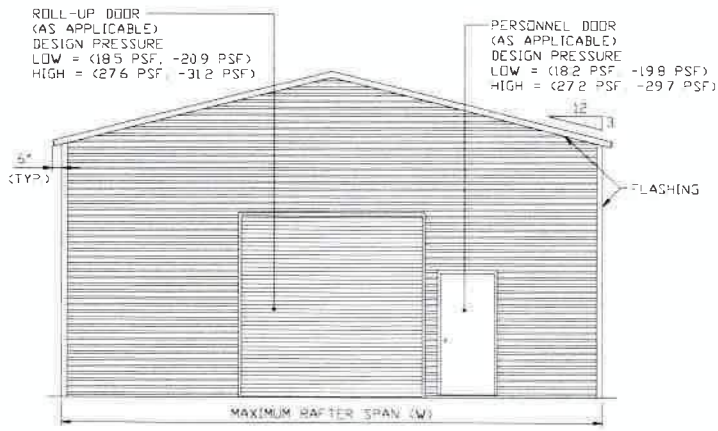

TYPICAL END ELEVATION

SCALE: NTS

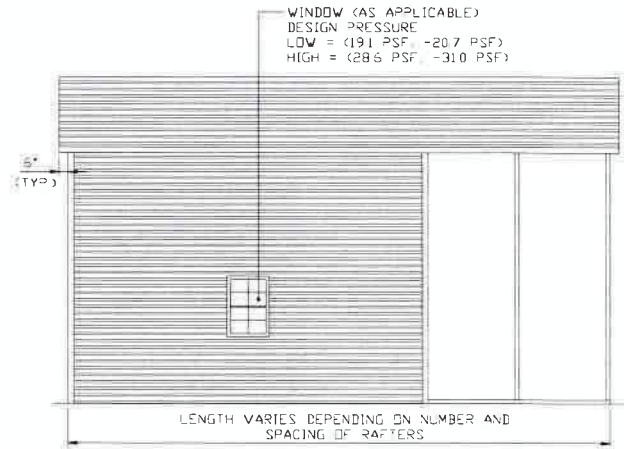

TYPICAL SIDE ELEVATION

SCALE: NTS

BOX FRAME RAFTER ENCLOSED BUILDING

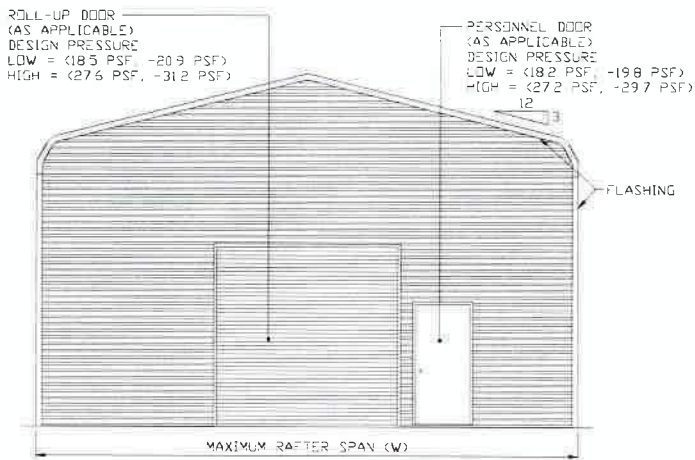

TYPICAL END ELEVATION

SCALE: NTS

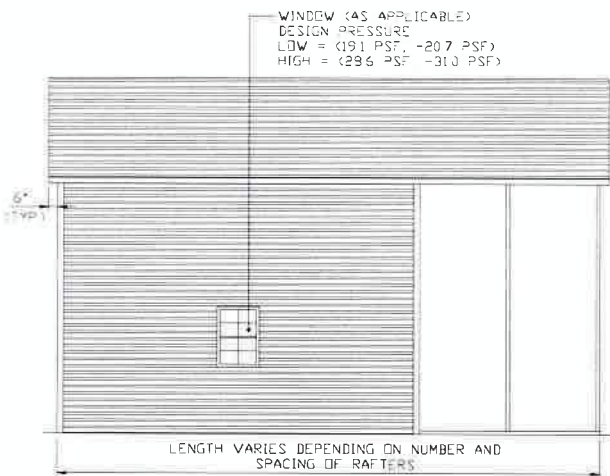

TYPICAL SIDE ELEVATION

SCALE: NTS



This item has been electronically signed and sealed by Wayne S. Moore, PE, using a Digital Signature and date.

Printed copies of this document are not considered signed and sealed and the signature must be verified on any electronic copies.

**MOORE AND ASSOCIATES
ENGINEERING AND CONSULTING, INC.**

DRAWN BY: JG

CHECKED BY: PDH

PROJECT MGR: WSM

CLIENT: TBS

**TUBULAR BUILDING SYSTEMS
631 SE INDUSTRIAL CIRCLE
LAKE CITY, FLORIDA 32025
30'-0" x 20'-0" UTILITY BUILDING EXP. B**

DATE: 7-29-21

SHT. 4

SCALE: NTS

DWG. NO: SK-2

**JOB NO: 16154S/
17300S/20352S**

REV: 3

THIS DOCUMENT IS THE PROPERTY OF MOORE AND ASSOCIATES ENGINEERING AND CONSULTING. THE UNAUTHORIZED REPRODUCTION, COPYING, OR OTHERWISE USE OF THIS DOCUMENT IS STRICTLY PROHIBITED AND ANY INFRINGEMENT THEREUPON MAY BE SUBJECT TO LEGAL ACTION.

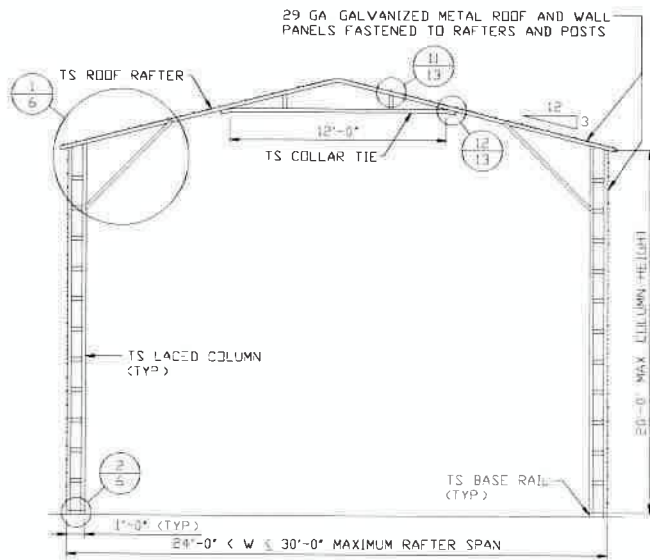

TYPICAL RAFTER/COLUMN END FRAME SECTION

SCALE: NTS

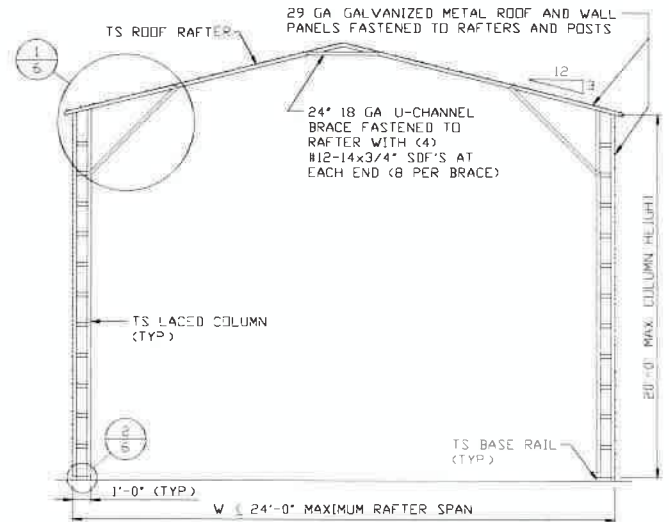

TYPICAL RAFTER/COLUMN END FRAME SECTION

SCALE: NTS

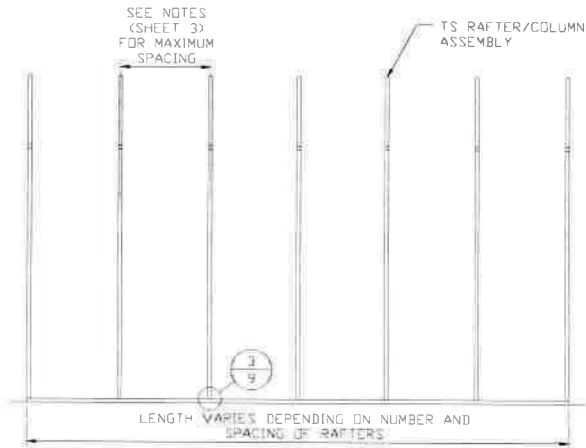

TYPICAL RAFTER/COLUMN SIDE FRAMING SECTION

SCALE: NTS



This item has been electronically signed and sealed by Wayne S. Moore, PE, using a Digital Signature and date.

Printed copies of this document are not considered signed and sealed and the signature must be verified on any electronic copies.

**MOORE AND ASSOCIATES
ENGINEERING AND CONSULTING, INC.**

DRAWN BY: JG

CHECKED BY: PDH

PROJECT MGR: WSM

CLIENT: TBS

**TUBULAR BUILDING SYSTEMS
631 SE INDUSTRIAL CIRCLE
LAKE CITY, FLORIDA 32025
30'-0"x20'-0" UTILITY BUILDING EXP. B**

DATE: 7-29-21

SCALE: NTS

DWG. NO: SK-2

**JOB NO: 16154S/
17300S/20352S**

REV: 3

THIS DOCUMENT IS THE PROPERTY OF MOORE AND ASSOCIATES ENGINEERING AND CONSULTING. THE UNAUTHORIZED REPRODUCTION, COPYING, OR OTHERWISE USE OF THIS DOCUMENT IS STRICTLY PROHIBITED AND ANY INFRINGEMENT THEREUPON MAY BE SUBJECT TO LEGAL ACTION.

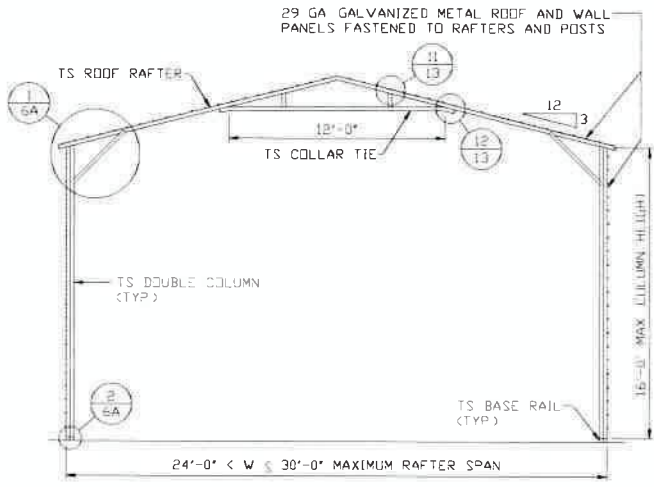

TYPICAL RAFTER/COLUMN END FRAME SECTION
SCALE: NTS

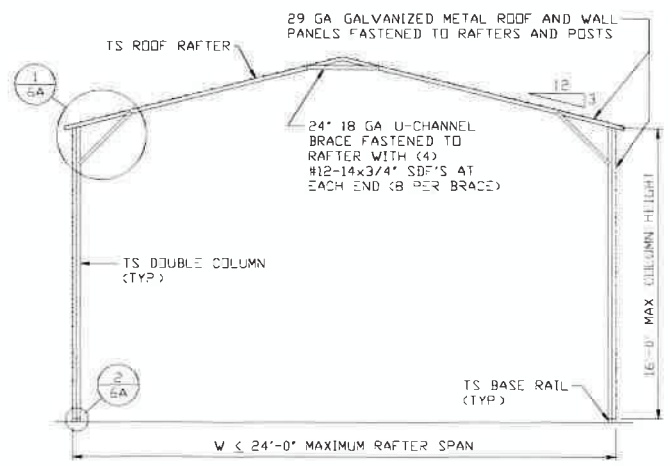

TYPICAL RAFTER/COLUMN END FRAME SECTION
SCALE: NTS

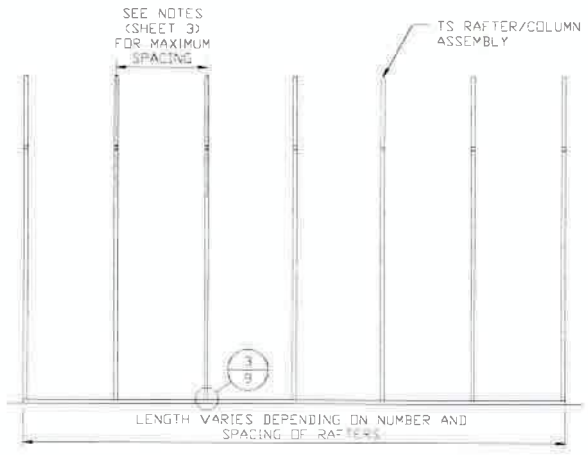

TYPICAL RAFTER/COLUMN SIDE FRAMING SECTION
SCALE: NTS



This item has been electronically signed and sealed by Wayne S. Moore, PE. using a Digital Signature and date.

Printed copies of this document are not considered signed and sealed and the signature must be verified on any electronic copies.

**MOORE AND ASSOCIATES
ENGINEERING AND CONSULTING, INC.**

DRAWN BY: JG

CHECKED BY: PDH

**TUBULAR BUILDING SYSTEMS
631 SE INDUSTRIAL CIRCLE
LAKE CITY, FLORIDA 32025
30'-0"X20'-0" UTILITY BUILDING EXP. B**

THIS DOCUMENT IS THE PROPERTY OF MOORE AND ASSOCIATES ENGINEERING AND CONSULTING. THE UNAUTHORIZED REPRODUCTION, COPYING, OR OTHERWISE USE OF THIS DOCUMENT IS STRICTLY PROHIBITED AND ANY INFRINGEMENT THEREUPON MAY BE SUBJECT TO LEGAL ACTION.

PROJECT MGR: WSM

CLIENT: TBS

DATE: 7-29-21

SCALE: NTS

**JOB NO: 16154S/
17300S/20352S**

SHT. 5A

DWG. NO: SK-2

REV: 3

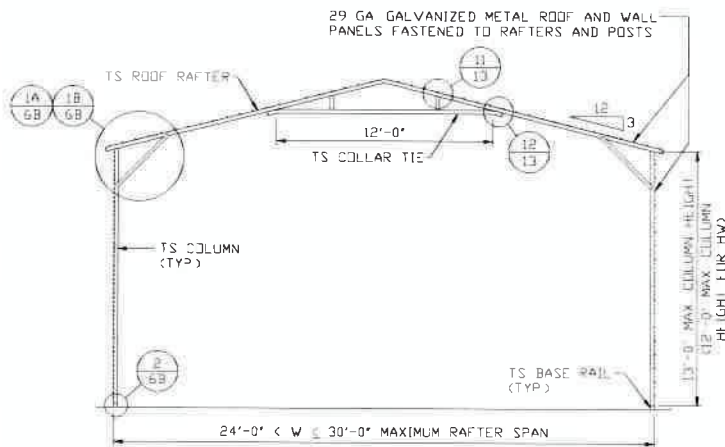

TYPICAL RAFTER/COLUMN END FRAME SECTION

SCALE: NTS

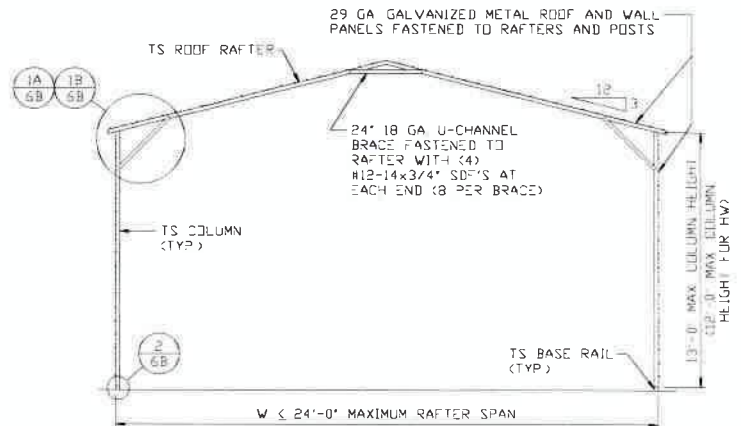

TYPICAL RAFTER/COLUMN END FRAME SECTION

SCALE: NTS

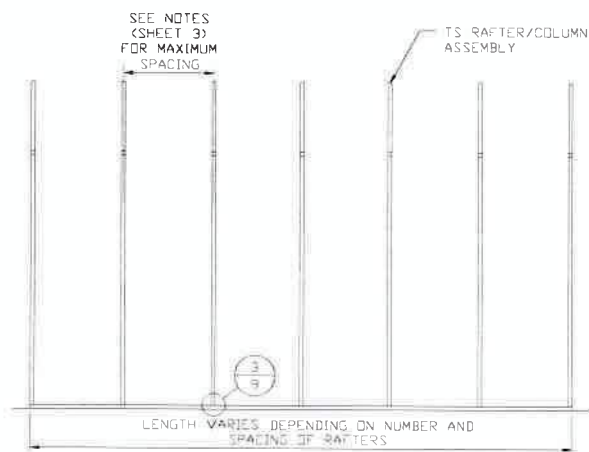

TYPICAL RAFTER/COLUMN SIDE FRAMING SECTION

SCALE: NTS

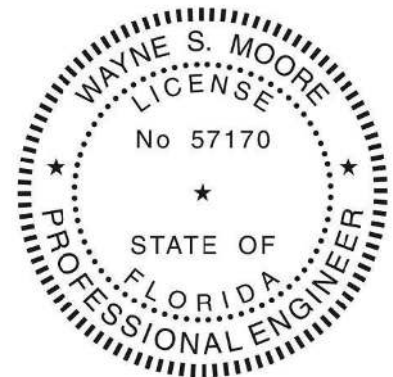

This item has been electronically signed and sealed by Wayne S. Moore, PE, using a Digital Signature and date.

Printed copies of this document are not considered signed and sealed and the signature must be verified on any electronic copies.

**MOORE AND ASSOCIATES
ENGINEERING AND CONSULTING, INC.**

DRAWN BY: JG

CHECKED BY: PDH

PROJECT MGR: WSM

CLIENT: TBS

**TUBULAR BUILDING SYSTEMS
631 SE INDUSTRIAL CIRCLE
LAKE CITY, FLORIDA 32025
30'-0"x20'-0" UTILITY BUILDING EXP. B**

DATE: 7-29-21

SHT. 5B

SCALE: NTS

DWG. NO: SK-2

**JOB NO: 16154S/
17300S/20352S**

REV: 3

THIS DOCUMENT IS THE PROPERTY OF MOORE AND ASSOCIATES ENGINEERING AND CONSULTING. THE UNAUTHORIZED REPRODUCTION, COPYING, OR OTHERWISE USE OF THIS DOCUMENT IS STRICTLY PROHIBITED AND ANY INFRINGEMENT THEREUPON MAY BE SUBJECT TO LEGAL ACTION.

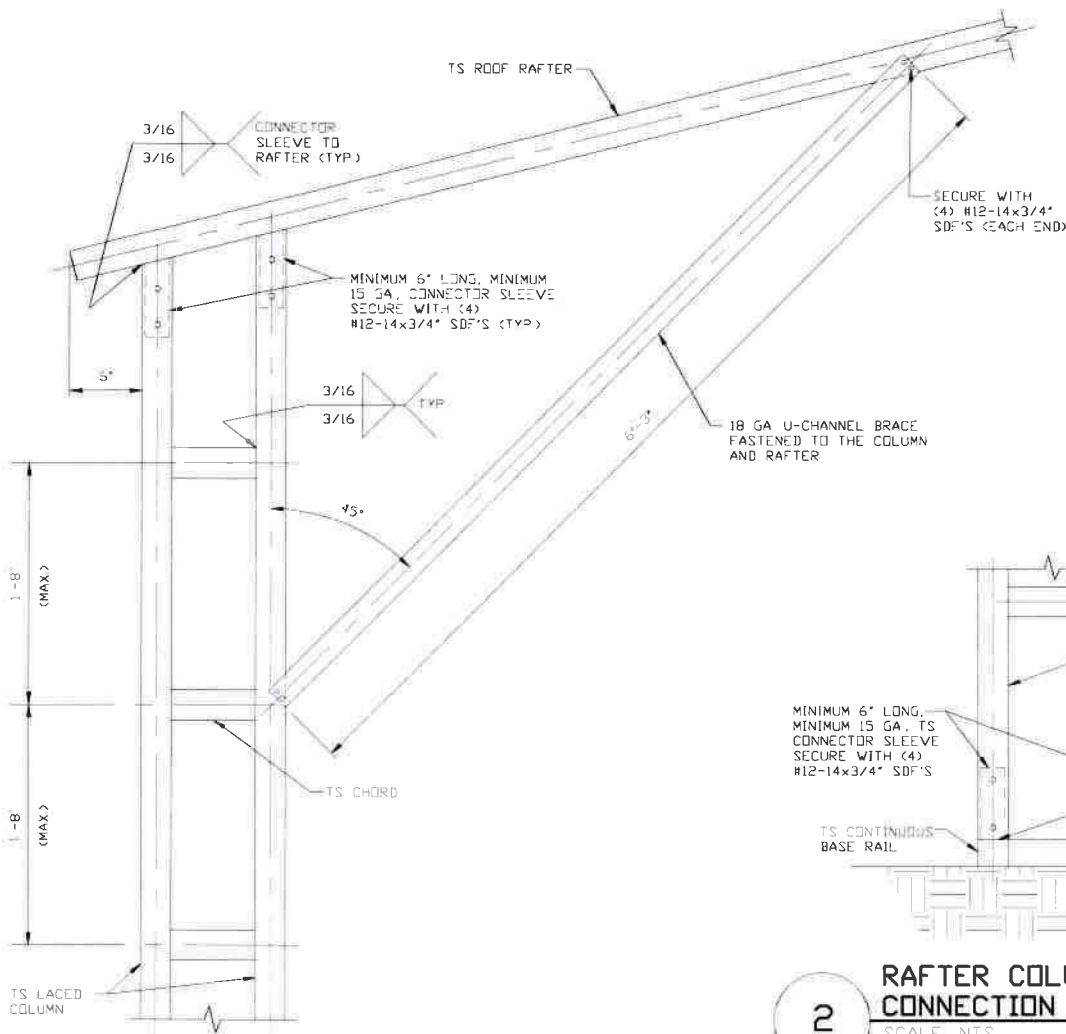

1 BOX EAVE RAFTER COLUMN CONNECTION DETAIL FOR HEIGHTS 16'-0" < TO ≤ 20'-0" SCALE: NTS

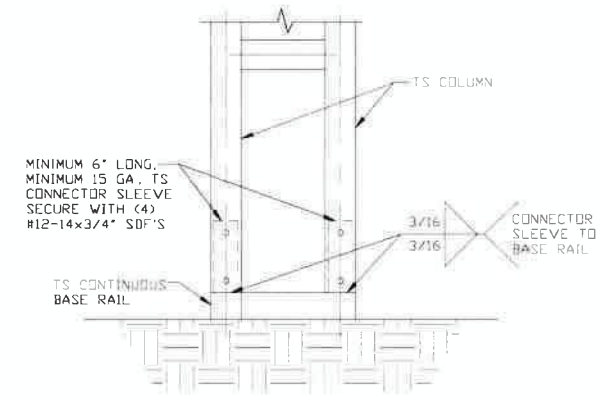

2 RAFTER COLUMN/BASE RAIL CONNECTION DETAIL SCALE: NTS

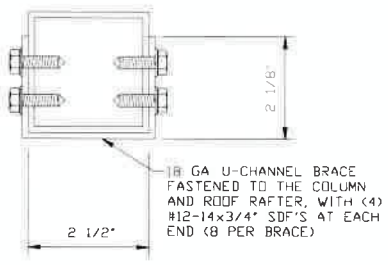

BRACE SECTION SCALE: NTS



This item has been electronically signed and sealed by Wayne S. Moore, PE, using a Digital Signature and date.

Printed copies of this document are not considered signed and sealed and the signature must be verified on any electronic copies.

MOORE AND ASSOCIATES ENGINEERING AND CONSULTING, INC.	DRAWN BY: JG	TUBULAR BUILDING SYSTEMS 631 SE INDUSTRIAL CIRCLE LAKE CITY, FLORIDA 32025 30'-0" x 20'-0" UTILITY BUILDING EXP. B		
	CHECKED BY: PDH			
PROJECT MGR: WSM	DATE: 7-29-21	SCALE: NTS	JOB NO: 16154S/ 17300S/20352S	
CLIENT: TBS	SHT. 6	DWG. NO: SK-2	REV: 3	

THIS DOCUMENT IS THE PROPERTY OF MOORE AND ASSOCIATES ENGINEERING AND CONSULTING. THE UNAUTHORIZED REPRODUCTION, COPYING, OR OTHERWISE USE OF THIS DOCUMENT IS STRICTLY PROHIBITED AND ANY INFRINGEMENT THEREUPON MAY BE SUBJECT TO LEGAL ACTION.

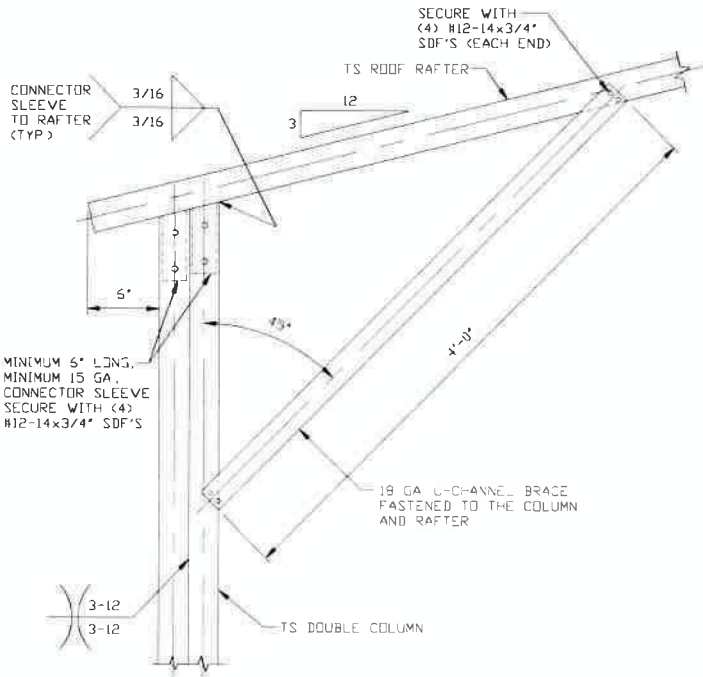

1 BOX EAVE RAFTER COLUMN CONNECTION DETAIL FOR HEIGHTS 13'-0" < TO ≤ 16'-0"

SCALE: NTS

NOTE: COLUMN HEIGHTS 12'-0" < TO ≤ 16'-0" FOR HIGH WIND

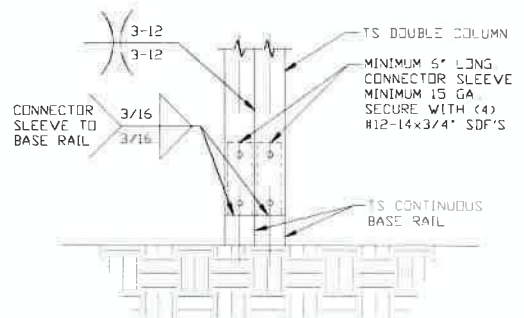

2 RAFTER COLUMN/BASE RAIL CONNECTION DETAIL

SCALE: NTS

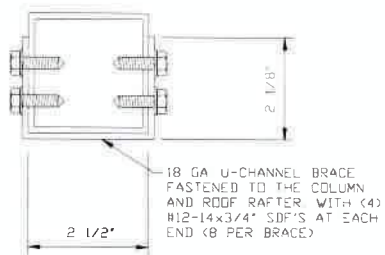

BRACE SECTION

SCALE: NTS



This item has been electronically signed and sealed by Wayne S. Moore, PE. using a Digital Signature and date.

Printed copies of this document are not considered signed and sealed and the signature must be verified on any electronic copies.

MOORE AND ASSOCIATES ENGINEERING AND CONSULTING, INC.

DRAWN BY: JG

CHECKED BY: PDH

PROJECT MGR: WSM

CLIENT: TBS

TUBULAR BUILDING SYSTEMS
631 SE INDUSTRIAL CIRCLE
LAKE CITY, FLORIDA 32025
30'-0" x 20'-0" UTILITY BUILDING EXP. B

DATE: 7-29-21

SHT. 6A

SCALE: NTS

DWG. NO: SK-2

JOB NO: 16154S/
17300S/20352S

REV: 3

THIS DOCUMENT IS THE PROPERTY OF MOORE AND ASSOCIATES ENGINEERING AND CONSULTING. THE UNAUTHORIZED REPRODUCTION, COPYING, OR OTHERWISE USE OF THIS DOCUMENT IS STRICTLY PROHIBITED AND ANY INFRINGEMENT THEREUPON MAY BE SUBJECT TO LEGAL ACTION.

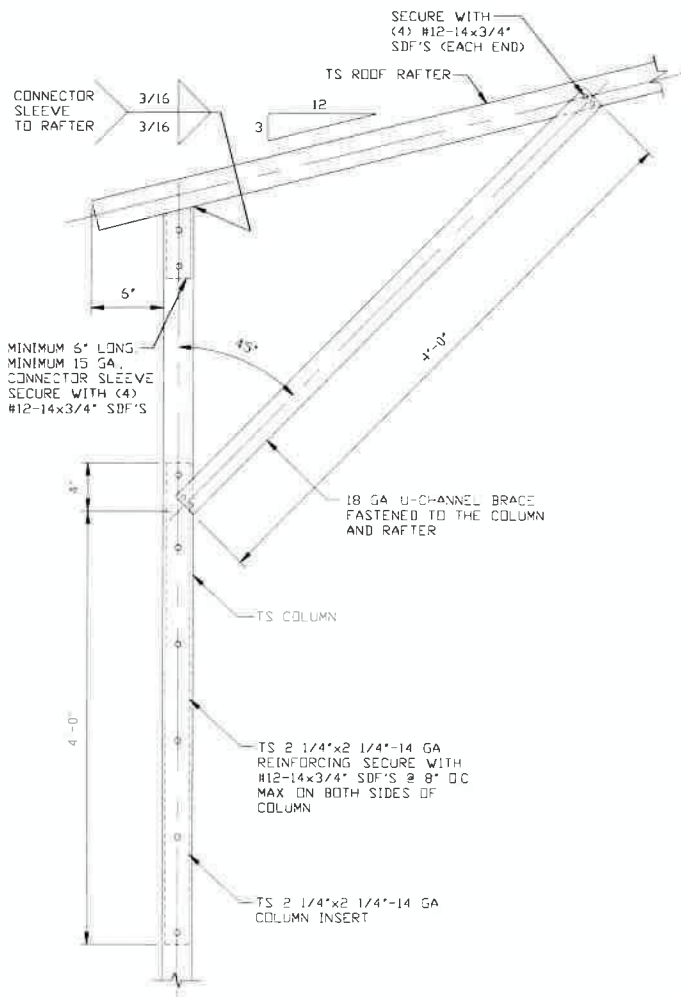

1A

BOX EAVE RAFTER COLUMN CONNECTION DETAIL FOR HEIGHTS 10'-0" < TO ≤ 13'-0"

SCALE: NTS
NOTE: MAXIMUM COLUMN HEIGHT IS 12'-0" FOR HIGH WIND

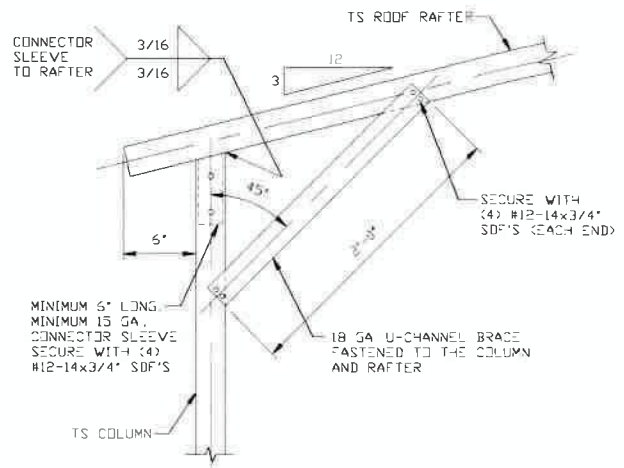

1B

BOX EAVE RAFTER COLUMN CONNECTION DETAIL FOR HEIGHTS ≤ 10'-0"

SCALE: NTS

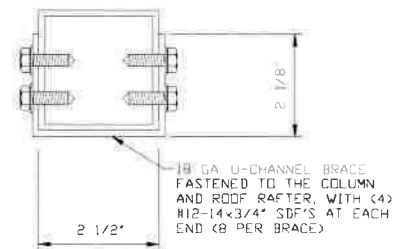

BRACE SECTION

SCALE: NTS

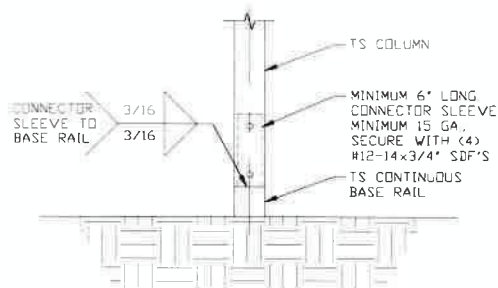

2

RAFTER COLUMN/BASE RAIL CONNECTION DETAIL

SCALE: NTS



This item has been electronically signed and sealed by Wayne S. Moore, PE, using a Digital Signature and date.

Printed copies of this document are not considered signed and sealed and the signature must be verified on any electronic copies.

MOORE AND ASSOCIATES ENGINEERING AND CONSULTING, INC.

DRAWN BY: JG

CHECKED BY: PDH

PROJECT MGR: WSM

CLIENT: TBS

TUBULAR BUILDING SYSTEMS
631 SE INDUSTRIAL CIRCLE
LAKE CITY, FLORIDA 32025
30'-0" x 20'-0" UTILITY BUILDING EXP. B

DATE: 7-29-21

SHT. 6B

SCALE: NTS

DWG. NO: SK-2

JOB NO: 16154S/
17300S/20352S

REV: 3

THIS DOCUMENT IS THE PROPERTY OF MOORE AND ASSOCIATES ENGINEERING AND CONSULTING. THE UNAUTHORIZED REPRODUCTION, COPYING, OR OTHERWISE USE OF THIS DOCUMENT IS STRICTLY PROHIBITED AND ANY INFRINGEMENT THEREUPON MAY BE SUBJECT TO LEGAL ACTION.

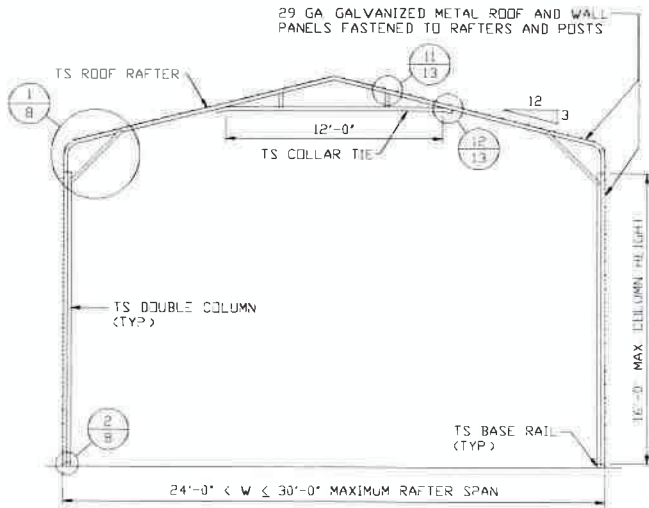

TYPICAL RAFTER/COLUMN END FRAME SECTION

SCALE: NTS

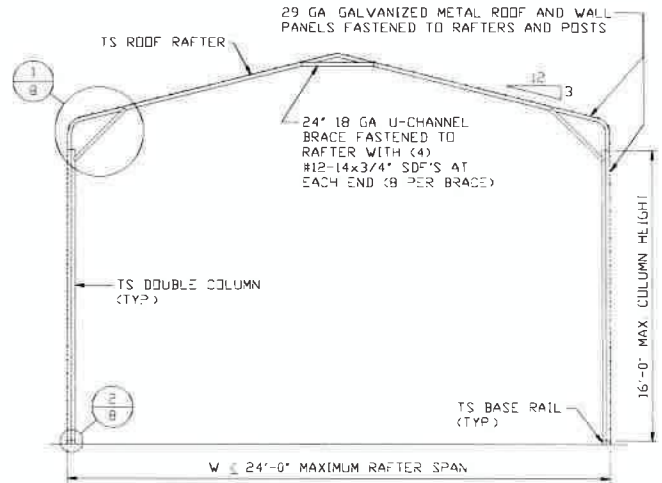

TYPICAL RAFTER/COLUMN END FRAME SECTION

SCALE: NTS

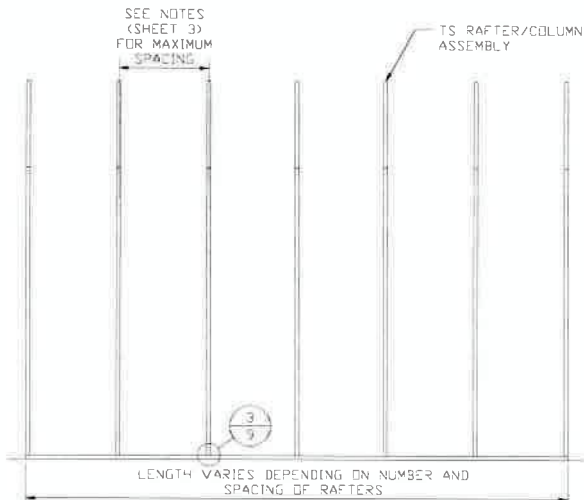

TYPICAL RAFTER/COLUMN SIDE FRAMING SECTION

SCALE: NTS



This item has been electronically signed and sealed by Wayne S. Moore, PE, using a Digital Signature and date.

Printed copies of this document are not considered signed and sealed and the signature must be verified on any electronic copies.

**MOORE AND ASSOCIATES
ENGINEERING AND CONSULTING, INC.**

DRAWN BY: JG

CHECKED BY: PDH

PROJECT MGR: WSM

CLIENT: TBS

**TUBULAR BUILDING SYSTEMS
631 SE INDUSTRIAL CIRCLE
LAKE CITY, FLORIDA 32025
30'-0"X20'-0" UTILITY BUILDING EXP. B**

DATE: 7-29-21

SHT. 7

SCALE: NTS

DWG. NO: SK-2

**JOB NO: 16154S/
17300S/20352S**

REV: 3

THIS DOCUMENT IS THE PROPERTY OF MOORE AND ASSOCIATES ENGINEERING AND CONSULTING. THE UNAUTHORIZED REPRODUCTION, COPYING, OR OTHERWISE USE OF THIS DOCUMENT IS STRICTLY PROHIBITED AND ANY INFRINGEMENT THEREUPON MAY BE SUBJECT TO LEGAL ACTION.

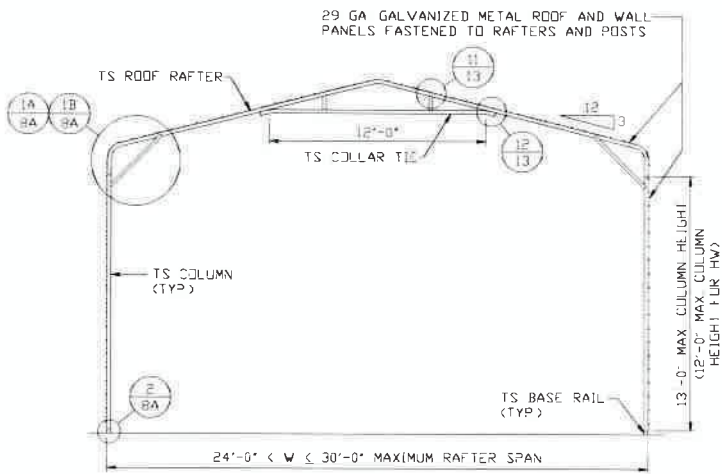

TYPICAL RAFTER/COLUMN END FRAME SECTION

SCALE: NTS

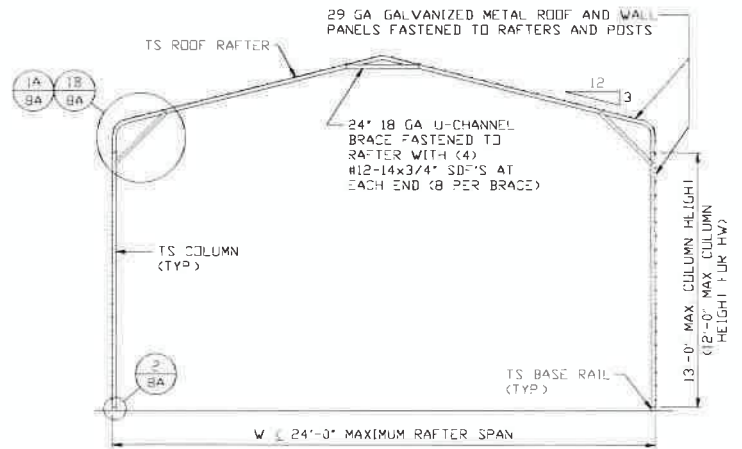

TYPICAL RAFTER/COLUMN END FRAME SECTION

SCALE: NTS

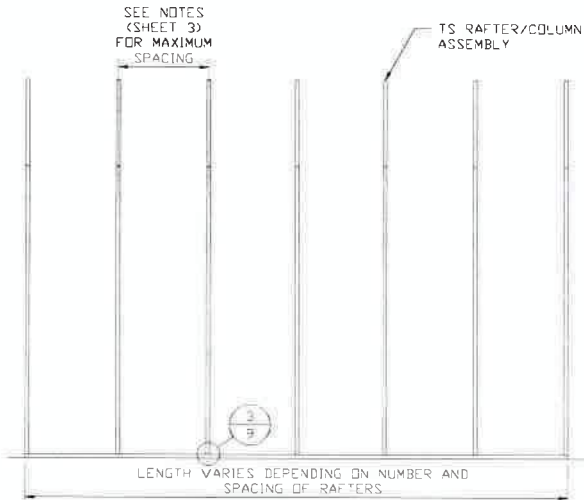

TYPICAL RAFTER/COLUMN SIDE FRAMING SECTION

SCALE: NTS



This item has been electronically signed and sealed by Wayne S. Moore, PE, using a Digital Signature and date.

Printed copies of this document are not considered signed and sealed and the signature must be verified on any electronic copies.

**MOORE AND ASSOCIATES
ENGINEERING AND CONSULTING, INC.**

DRAWN BY: JG

CHECKED BY: PDH

PROJECT MGR: WSM

CLIENT: TBS

TUBULAR BUILDING SYSTEMS
631 SE INDUSTRIAL CIRCLE
LAKE CITY, FLORIDA 32025
30'-0" x 20'-0" UTILITY BUILDING EXP. B

DATE: 7-29-21

SCALE: NTS

JOB NO: 16154S/
17300S/20352S

SHT. 7A

DWG. NO: SK-2

REV: 3

THIS DOCUMENT IS THE PROPERTY OF MOORE AND ASSOCIATES ENGINEERING AND CONSULTING. THE UNAUTHORIZED REPRODUCTION, COPYING, OR OTHERWISE USE OF THIS DOCUMENT IS STRICTLY PROHIBITED AND ANY INFRINGEMENT THEREUPON MAY BE SUBJECT TO LEGAL ACTION.

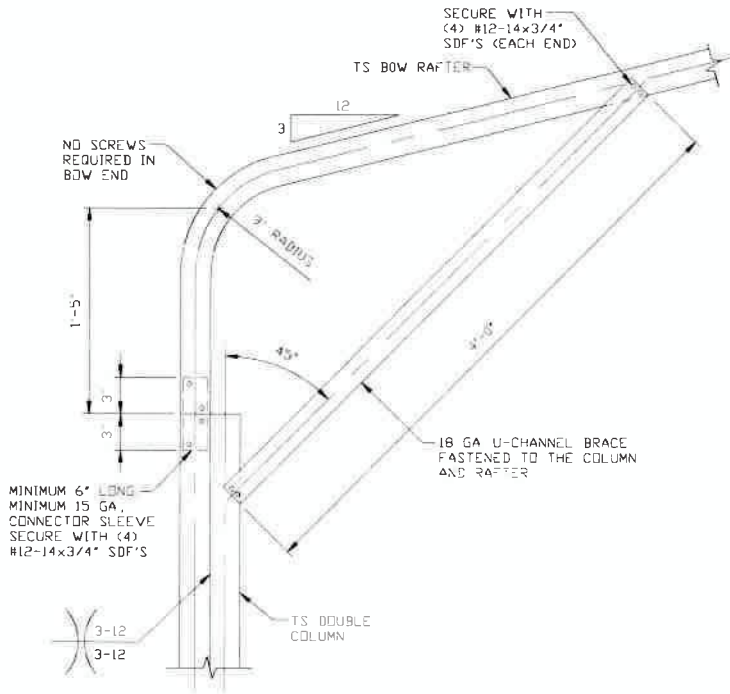

1 BOX EAVE RAFTER COLUMN CONNECTION DETAIL FOR HEIGHTS 13'-0" < TO ≤ 16'-0"

SCALE: NTS
NOTE: COLUMN HEIGHTS 12'-0" < TO ≤ 16'-0" FOR HIGH WIND

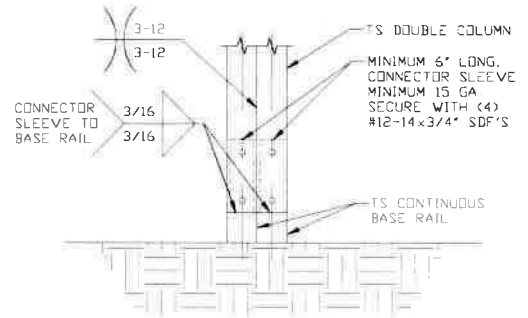

2 RAFTER COLUMN/BASE RAIL CONNECTION DETAIL

SCALE: NTS

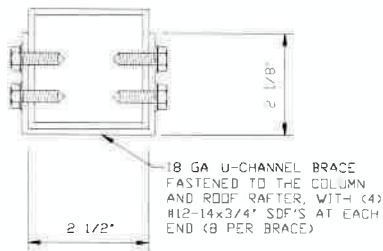

BRACE SECTION

SCALE: NTS



This item has been electronically signed and sealed by Wayne S. Moore, PE, using a Digital Signature and date.

Printed copies of this document are not considered signed and sealed and the signature must be verified on any electronic copies.

**MOORE AND ASSOCIATES
ENGINEERING AND CONSULTING, INC.**

DRAWN BY: JG

CHECKED BY: PDH

PROJECT MGR: WSM

CLIENT: TBS

TUBULAR BUILDING SYSTEMS
631 SE INDUSTRIAL CIRCLE
LAKE CITY, FLORIDA 32025
30'-0" x 20'-0" UTILITY BUILDING EXP. B

DATE: 7-29-21

SHT. 8

SCALE: NTS

DWG. NO: SK-2

JOB NO: 16154S/
17300S/20352S

REV: 3

THIS DOCUMENT IS THE PROPERTY OF MOORE AND ASSOCIATES ENGINEERING AND CONSULTING. THE UNAUTHORIZED REPRODUCTION, COPYING, OR OTHERWISE USE OF THIS DOCUMENT IS STRICTLY PROHIBITED AND ANY INFRINGEMENT THEREUPON MAY BE SUBJECT TO LEGAL ACTION.

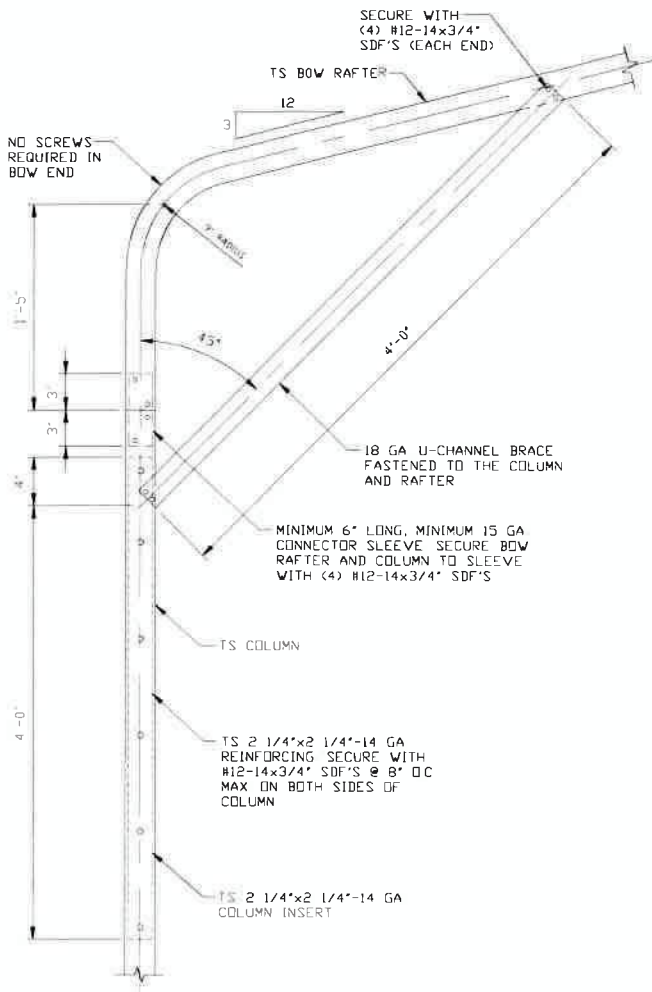

1A BOX EAVE RAFTER COLUMN CONNECTION DETAIL FOR HEIGHTS 10'-0" < TO <= 13'-0" SCALE: NTS

NOTE: MAXIMUM COLUMN HEIGHT IS 12'-0" FOR HIGH WIND

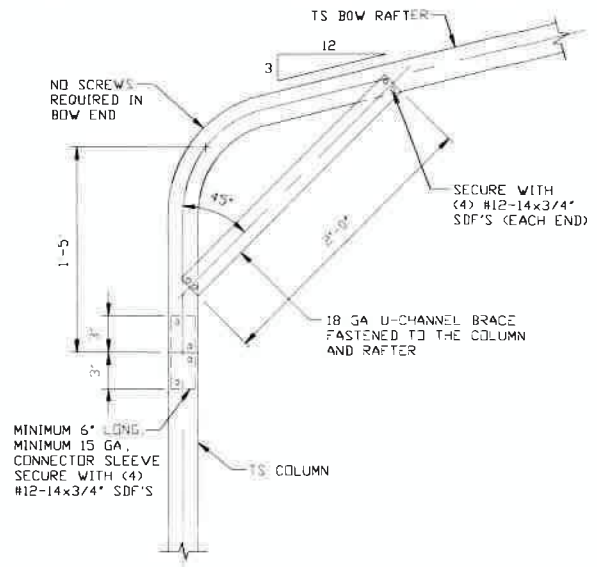

1B BOX EAVE RAFTER COLUMN CONNECTION DETAIL FOR HEIGHTS <= 10'-0" SCALE: NTS

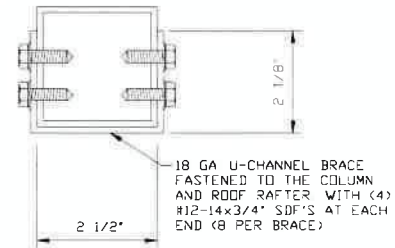

BRACE SECTION SCALE: NTS

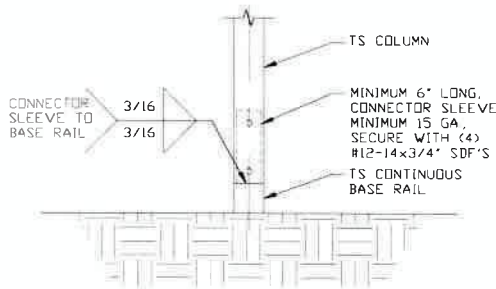

2 RAFTER COLUMN/BASE RAIL CONNECTION DETAIL SCALE: NTS

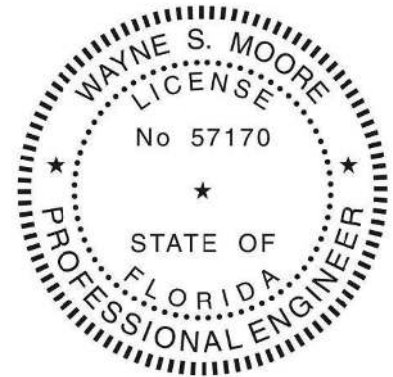

This item has been electronically signed and sealed by Wayne S. Moore, PE, using a Digital Signature and date.

Printed copies of this document are not considered signed and sealed and the signature must be verified on any electronic copies.

MOORE AND ASSOCIATES ENGINEERING AND CONSULTING, INC.

DRAWN BY: JG

CHECKED BY: PDH

PROJECT MGR: WSM

CLIENT: TBS

TUBULAR BUILDING SYSTEMS
631 SE INDUSTRIAL CIRCLE
LAKE CITY, FLORIDA 32025
30'-0" x 20'-0" UTILITY BUILDING EXP. B

DATE: 7-29-21

SHT. 8A

SCALE: NTS

DWG. NO: SK-2

**JOB NO: 16154S/
17300S/20352S**

REV: 3

THIS DOCUMENT IS THE PROPERTY OF MOORE AND ASSOCIATES ENGINEERING AND CONSULTING. THE UNAUTHORIZED REPRODUCTION, COPYING, OR OTHERWISE USE OF THIS DOCUMENT IS STRICTLY PROHIBITED AND ANY INFRINGEMENT THEREUPON MAY BE SUBJECT TO LEGAL ACTION.

BASE RAIL ANCHORAGE OPTIONS FOR LOW AND HIGH WIND SPEED

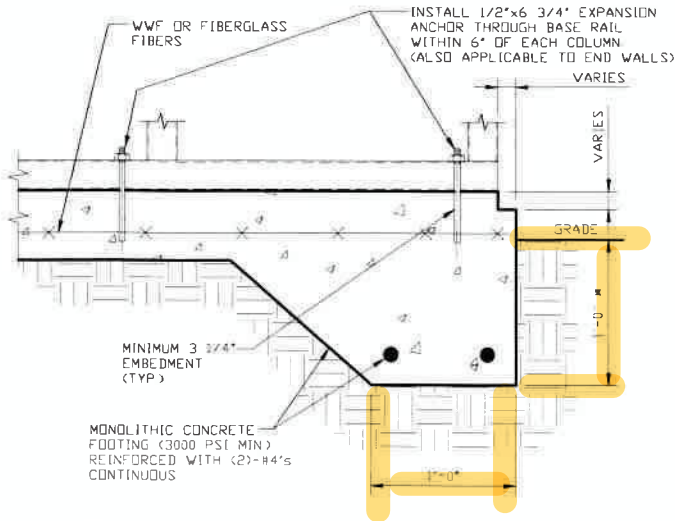

3A CONCRETE MONOLITHIC SLAB BASE RAIL ANCHORAGE
 SCALE: NTS
 MINIMUM ANCHOR EDGE DISTANCE IS 4"
 * COORDINATE WITH LOCAL CODES/ORD REGARDING MINIMUM FROST DEPTH REQ

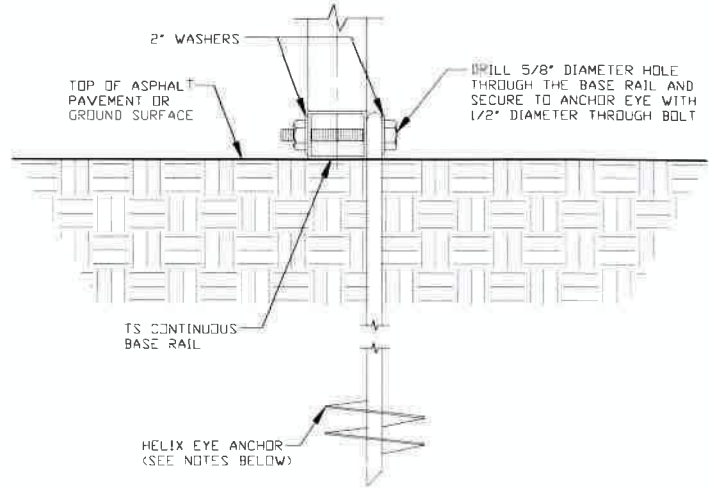

3B GROUND BASE HELIX ANCHORAGE
 SCALE: NTS
 (CAN BE USED FOR ASPHALT)
 * COORDINATE WITH LOCAL CODES/ORD REGARDING MINIMUM FROST DEPTH REQ

GENERAL NOTES

NOTE: CONCRETE MONOLITHIC SLAB DESIGN ON MINIMUM SOIL BEARING CAPACITY OF 1,500 PSF

CONCRETE:

CONCRETE SHALL HAVE A MINIMUM SPECIFIED COMPRESSIVE STRENGTH OF 3,000 PSI AT 28 DAYS

COVER OVER REINFORCING STEEL:

FOR FOUNDATIONS, MINIMUM CONCRETE COVER OVER REINFORCING BARS SHALL BE PER ACI-318:
 3 INCHES IN FOUNDATIONS WHERE THE CONCRETE IS CAST AGAINST AND PERMANENTLY IN CONTACT WITH THE EARTH OR EXPOSED TO THE EARTH OR WEATHER, AND 1 1/2 INCHES ELSEWHERE

REINFORCING STEEL:

THE TURNDOWN REINFORCING STEEL SHALL BE ASTM A615 GRADE SO THE SLAB REINFORCEMENT SHALL BE WELDED WIRE FABRIC MEETING ASTM A185 OR FIBERGLASS FIBER REINFORCEMENT.

REINFORCEMENT MAY BE BENT IN THE SHOP OR THE FIELD PROVIDED:

- 1 REINFORCEMENT IS BENT COLD
- 2 THE DIAMETER OF THE BEND, MEASURED ON THE INSIDE OF THE BAR, IS NOT LESS THAN SIX-BAR DIAMETERS
- 3 REINFORCEMENT PARTIALLY EMBEDDED IN CONCRETE SHALL NOT BE FIELD BENT

HELIX ANCHOR NOTES:

- 1 FOR VERY DENSE AND/OR CEMENTED SANDS, COARSE GRAVEL AND COBBLES, CALICHE, PRELOADED SILTS AND CLAYS USE MINIMUM (2) 4" HELICES WITH MINIMUM 30 INCH EMBEDMENT
- 2 FOR CORAL USE MINIMUM (2) 4" HELICES WITH MINIMUM 30 INCH EMBEDMENT
- 3 FOR MEDIUM DENSE COARSE SANDS, SANDY GRAVELS, VERY STIFF SILTS, AND CLAYS USE MINIMUM (2) 4" HELICES WITH MINIMUM 30 INCH EMBEDMENT
- 4 FOR LOOSE TO MEDIUM DENSE SANDS, FIRM TO STIFF CLAYS AND SILTS ALLUVIAL FILL USE MINIMUM (2) 6" HELICES WITH MINIMUM 50 INCH EMBEDMENT
- 5 FOR VERY LOOSE TO MEDIUM DENSE SANDS, FIRM TO STIFFER CLAYS AND SILTS, ALLUVIAL FILL USE MINIMUM (2) 8" HELICES WITH MINIMUM 60 INCH EMBEDMENT



This item has been electronically signed and sealed by Wayne S. Moore, PE, using a Digital Signature and date.

Printed copies of this document are not considered signed and sealed and the signature must be verified on any electronic copies.

**MOORE AND ASSOCIATES
 ENGINEERING AND CONSULTING, INC.**

DRAWN BY: JG

CHECKED BY: PDH

PROJECT MGR: WSM

CLIENT: TBS

TUBULAR BUILDING SYSTEMS
 631 SE INDUSTRIAL CIRCLE
 LAKE CITY, FLORIDA 32025
 30'-0" x 20'-0" UTILITY BUILDING EXP. B

DATE: 7-29-21

SCALE: NTS

JOB NO: 16154S/
 17300S/20352S

SHT. 9

DWG. NO: SK-2

REV: 3

THIS DOCUMENT IS THE PROPERTY OF MOORE AND ASSOCIATES ENGINEERING AND CONSULTING. THE UNAUTHORIZED REPRODUCTION, COPYING, OR OTHERWISE USE OF THIS DOCUMENT IS STRICTLY PROHIBITED AND ANY INFRINGEMENT THEREUPON MAY BE SUBJECT TO LEGAL ACTION.

OPTIONAL FOUNDATION ANCHORAGE FOR LOW AND HIGH WIND SPEED

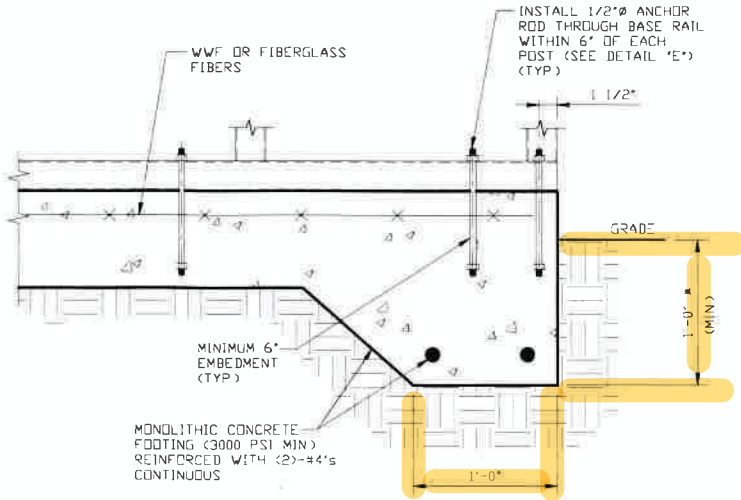

3C

CONCRETE MONOLITHIC SLAB BASE RAIL ANCHORAGE

SCALE: NTS
 MINIMUM ANCHOR EDGE DISTANCE IS 1 1/2"
 * COORDINATE WITH LOCAL CODES/ORD REGARDING MINIMUM FROST DEPTH REQ

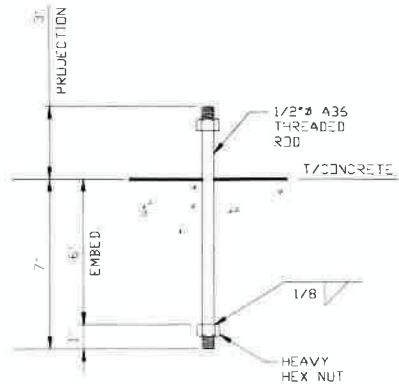

3D

ANCHOR ROD THROUGH BASE RAIL DETAIL

SCALE: NTS

GENERAL NOTES

NOTE: CONCRETE MONOLITHIC SLAB DESIGN ON MINIMUM SOIL BEARING CAPACITY OF 1,500 PSF

CONCRETE:

CONCRETE SHALL HAVE A MINIMUM SPECIFIED COMPRESSIVE STRENGTH OF 3,000 PSI AT 28 DAYS

COVER OVER REINFORCING STEEL:

FOR FOUNDATIONS, MINIMUM CONCRETE COVER OVER REINFORCING BARS SHALL BE PER ACI-318
 3 INCHES IN FOUNDATIONS WHERE THE CONCRETE IS CAST AGAINST AND PERMANENTLY IN CONTACT WITH THE EARTH OR EXPOSED TO THE EARTH OR WEATHER, AND 1 1/2 INCHES ELSEWHERE

REINFORCING STEEL:

THE TURNDOWN REINFORCING STEEL SHALL BE ASTM A615 GRADE 60 THE SLAB REINFORCEMENT SHALL BE WELDED WIRE FABRIC MEETING ASTM A185 OR FIBERGLASS FIBER REINFORCEMENT

REINFORCEMENT MAY BE BENT IN THE SHOP OR THE FIELD PROVIDED:

- 1 REINFORCEMENT IS BENT COLD
- 2 THE DIAMETER OF THE BEND, MEASURED ON THE INSIDE OF THE BAR, IS NOT LESS THAN SIX-BAR DIAMETERS
- 3 REINFORCEMENT PARTIALLY EMBEDDED IN CONCRETE SHALL NOT BE FIELD BENT



This item has been electronically signed and sealed by Wayne S. Moore, PE, using a Digital Signature and date.

Printed copies of this document are not considered signed and sealed and the signature must be verified on any electronic copies.

**MOORE AND ASSOCIATES
 ENGINEERING AND CONSULTING, INC.**

DRAWN BY: JG

CHECKED BY: PDH

PROJECT MGR: WSM

CLIENT: TBS

TUBULAR BUILDING SYSTEMS
 631 SE INDUSTRIAL CIRCLE
 LAKE CITY, FLORIDA 32025
 30'-0" x 20'-0" UTILITY BUILDING EXP. B

DATE: 7-29-21

SHT. 9A

SCALE: NTS

DWG. NO: SK-2

JOB NO: 16154S/
 17300S/20352S

REV: 3

THIS DOCUMENT IS THE PROPERTY OF MOORE AND ASSOCIATES ENGINEERING AND CONSULTING. THE UNAUTHORIZED REPRODUCTION, COPYING, OR OTHERWISE USE OF THIS DOCUMENT IS STRICTLY PROHIBITED AND ANY INFRINGEMENT THEREUPON MAY BE SUBJECT TO LEGAL ACTION.

BASE RAIL ANCHORAGE OPTION

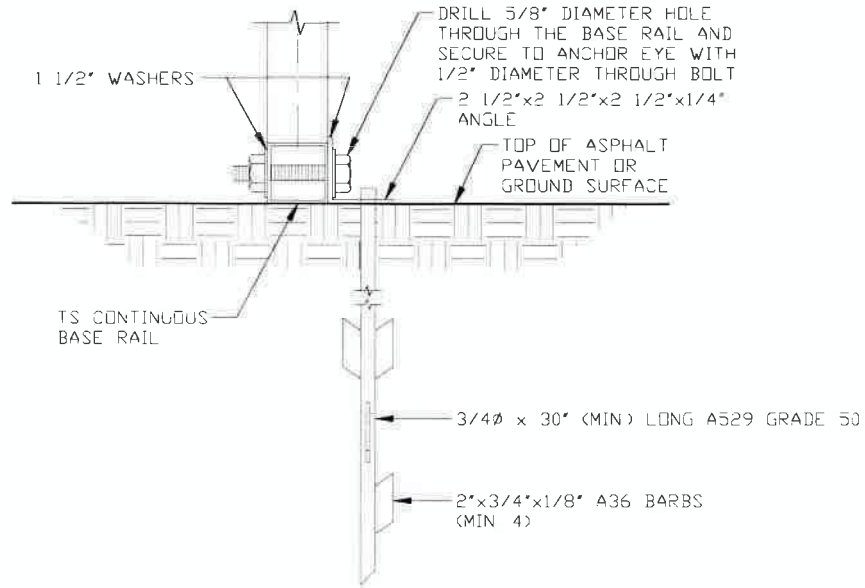

3E ASPHALT BASE ANCHORAGE (HP 9 BARBED DRIVE ANCHOR)
 SCALE: NTS
 (CAN BE USED FOR ASPHALT)
 * COORDINATE WITH LOCAL CODES/ORD
 REGARDING MINIMUM FROST DEPTH REQ



This item has been electronically signed and sealed by Wayne S. Moore, PE, using a Digital Signature and date.

Printed copies of this document are not considered signed and sealed and the signature must be verified on any electronic copies.

**MOORE AND ASSOCIATES
 ENGINEERING AND CONSULTING, INC.**

DRAWN BY: JG

CHECKED BY: PDH

PROJECT MGR: WSM

CLIENT: TBS

**TUBULAR BUILDING SYSTEMS
 631 SE INDUSTRIAL CIRCLE
 LAKE CITY, FLORIDA 32025
 30'-0"x20'-0" UTILITY BUILDING EXP. B**

DATE: 7-29-21

SHT. 9B

SCALE: NTS

DWG. NO: SK-2

**JOB NO: 16154S/
 17300S/20352S**

REV: 3

THIS DOCUMENT IS THE PROPERTY OF MOORE AND ASSOCIATES ENGINEERING AND CONSULTING. THE UNAUTHORIZED REPRODUCTION, COPYING, OR OTHERWISE USE OF THIS DOCUMENT IS STRICTLY PROHIBITED AND ANY INFRINGEMENT THEREUPON MAY BE SUBJECT TO LEGAL ACTION.

BASE RAIL ANCHORAGE OPTIONS

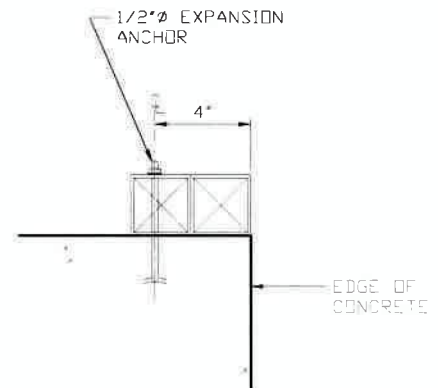
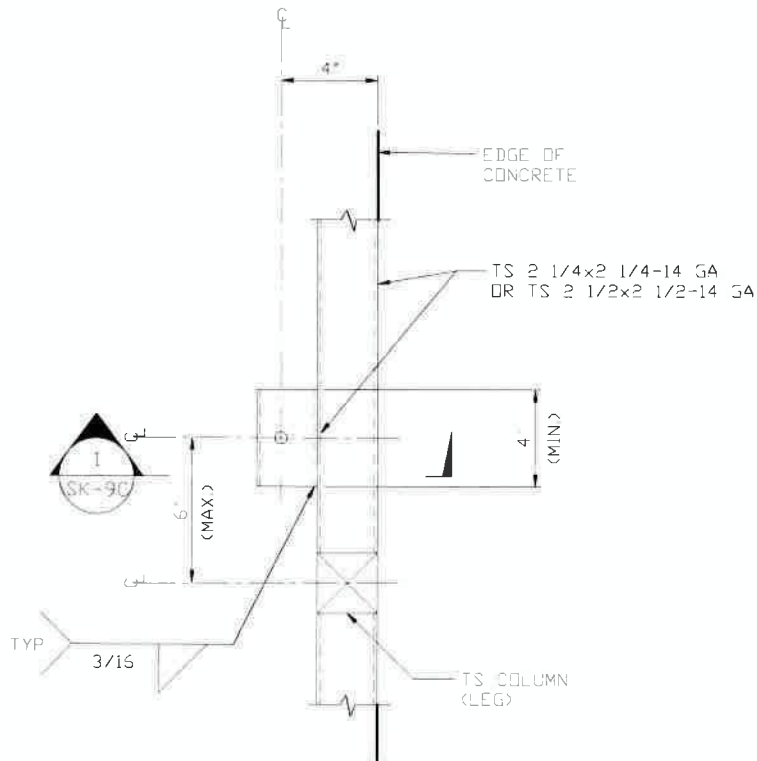

SECTION 1
SCALE: NTS 1
SK-9C

TYPICAL ANCHOR DETAIL WHEN BASE RAIL IS NEAR EDGE OF CONCRETE

SCALE: NTS



This item has been electronically signed and sealed by Wayne S. Moore, PE, using a Digital Signature and date.

Printed copies of this document are not considered signed and sealed and the signature must be verified on any electronic copies.

**MOORE AND ASSOCIATES
ENGINEERING AND CONSULTING, INC.**

DRAWN BY: JG

CHECKED BY: PDH

PROJECT MGR: WSM

CLIENT: TBS

TUBULAR BUILDING SYSTEMS
631 SE INDUSTRIAL CIRCLE
LAKE CITY, FLORIDA 32025
30'-0" x 20'-0" UTILITY BUILDING EXP. B

DATE: 7-29-21

SHT. 9C

SCALE: NTS

DWG. NO: SK-2

**JOB NO: 16154S/
17300S/20352S**

REV: 3

THIS DOCUMENT IS THE PROPERTY OF MOORE AND ASSOCIATES ENGINEERING AND CONSULTING. THE UNAUTHORIZED REPRODUCTION, COPYING, OR OTHERWISE USE OF THIS DOCUMENT IS STRICTLY PROHIBITED AND ANY INFRINGEMENT THEREUPON MAY BE SUBJECT TO LEGAL ACTION.

BOX EAVE RAFTER END WALL AND SIDE WALL OPENINGS

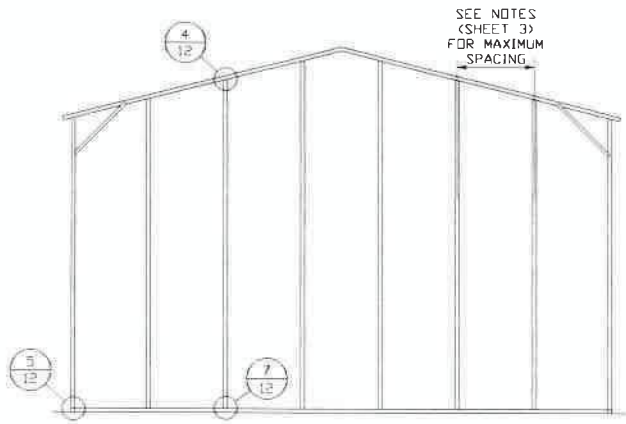

**TYPICAL BOX EAVE RAFTER
END WALL FRAMING SECTION**

SCALE: NTS

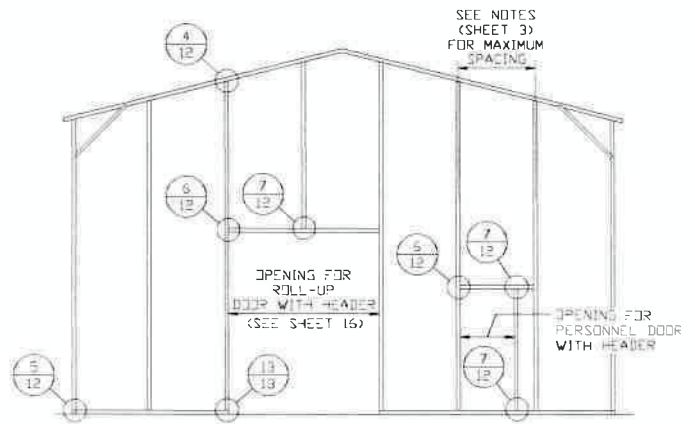

**TYPICAL BOX EAVE RAFTER END
WALL OPENINGS FRAMING SECTION**

SCALE: NTS

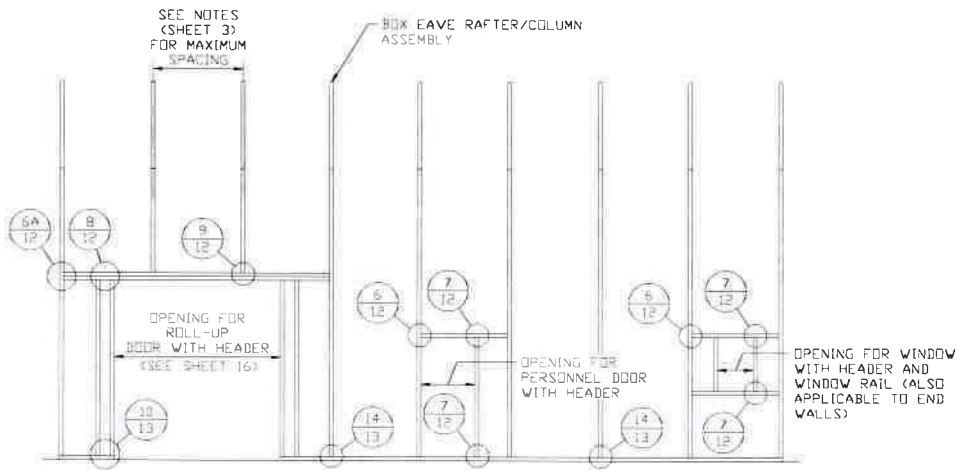

**TYPICAL BOX EAVE RAFTER SIDE
WALL OPENINGS FRAMING SECTION**

SCALE: NTS



This item has been electronically signed and sealed by Wayne S. Moore, PE. using a Digital Signature and date.

Printed copies of this document are not considered signed and sealed and the signature must be verified on any electronic copies.

**MOORE AND ASSOCIATES
ENGINEERING AND CONSULTING, INC.**

DRAWN BY: JG

CHECKED BY: PDH

PROJECT MGR: WSM

CLIENT: TBS

**TUBULAR BUILDING SYSTEMS
631 SE INDUSTRIAL CIRCLE
LAKE CITY, FLORIDA 32025
30'-0"X20'-0" UTILITY BUILDING EXP. B**

DATE: 7-29-21

SHT. 10

SCALE: NTS

DWG. NO: SK-2

**JOB NO: 16154S/
17300S/20352S**

REV: 3

THIS DOCUMENT IS THE PROPERTY OF MOORE AND ASSOCIATES ENGINEERING AND CONSULTING. THE UNAUTHORIZED REPRODUCTION, COPYING, OR OTHERWISE USE OF THIS DOCUMENT IS STRICTLY PROHIBITED AND ANY INFRINGEMENT THEREUPON MAY BE SUBJECT TO LEGAL ACTION.

BOW RAFTER END WALL AND SIDE WALL OPENINGS

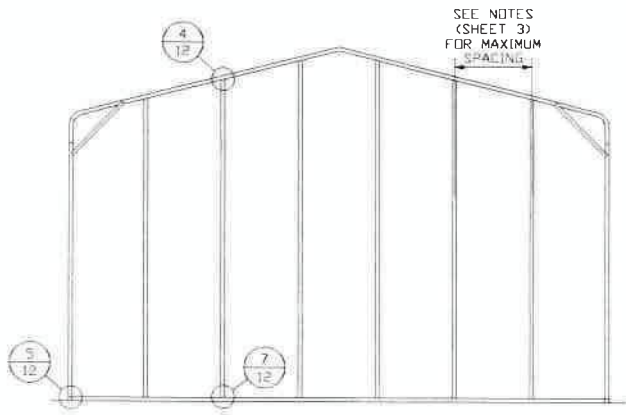

**TYPICAL BOX EAVE RAFTER
END WALL FRAMING SECTION**

SCALE: NTS

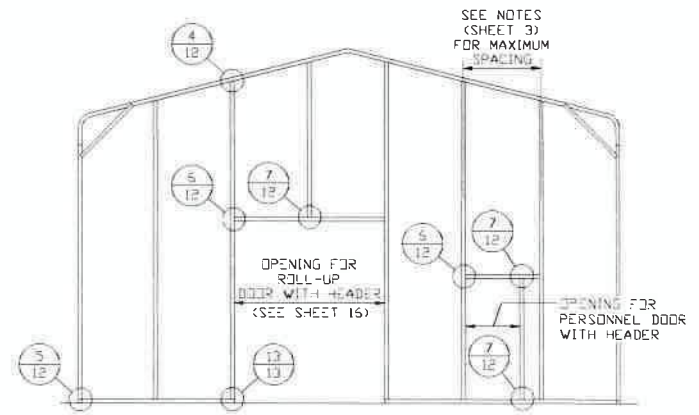

**TYPICAL BOX EAVE RAFTER END
WALL OPENINGS FRAMING SECTION**

SCALE: NTS

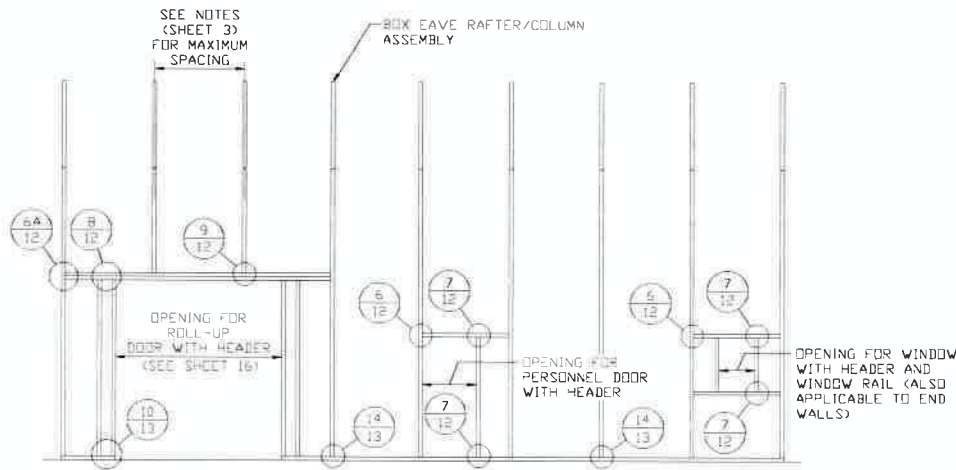

**TYPICAL BOX EAVE RAFTER SIDE
WALL OPENINGS FRAMING SECTION**

SCALE: NTS

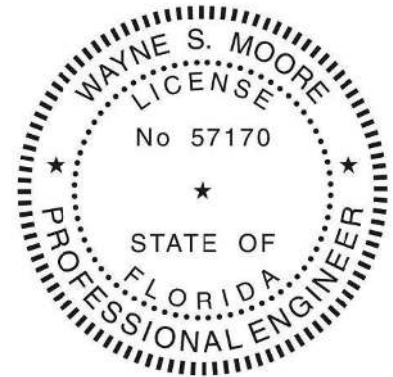

This item has been electronically signed and sealed by Wayne S. Moore, PE. using a Digital Signature and date.

Printed copies of this document are not considered signed and sealed and the signature must be verified on any electronic copies.

**MOORE AND ASSOCIATES
ENGINEERING AND CONSULTING, INC.**

DRAWN BY: JG

CHECKED BY: PDH

PROJECT MGR: WSM

CLIENT: TBS

TUBULAR BUILDING SYSTEMS
631 SE INDUSTRIAL CIRCLE
LAKE CITY, FLORIDA 32025
30'-0"X20'-0" UTILITY BUILDING EXP. B

DATE: 7-29-21

SHT. 11

SCALE: NTS

DWG. NO: SK-2

JOB NO: 16154S/
17300S/20352S

REV: 3

THIS DOCUMENT IS THE PROPERTY OF MOORE AND ASSOCIATES ENGINEERING AND CONSULTING. THE UNAUTHORIZED REPRODUCTION, COPYING, OR OTHERWISE USE OF THIS DOCUMENT IS STRICTLY PROHIBITED AND ANY INFRINGEMENT THEREUPON MAY BE SUBJECT TO LEGAL ACTION.

CONNECTION DETAILS

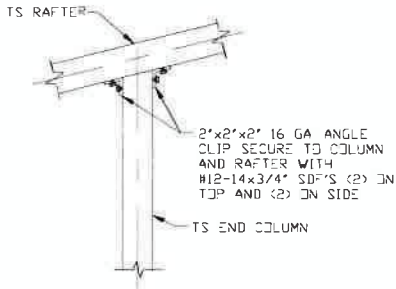

4

END COLUMN/RAFTER CONNECTION DETAIL

SCALE: NTS

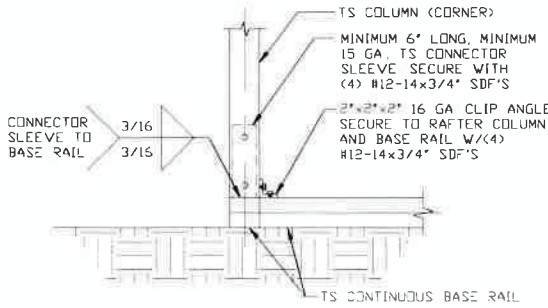

5

END COLUMN/BASE RAIL CONNECTION DETAIL

SCALE: NTS

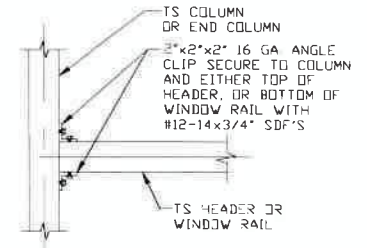

6

HEADER OR WINDOW RAIL TO COLUMN CONNECTION DETAIL

SCALE: NTS

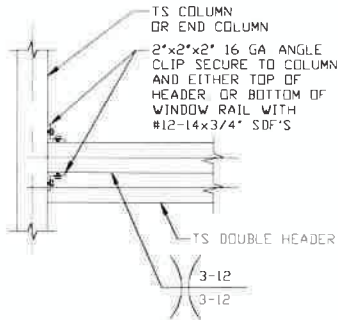

6A

DOUBLE HEADER TO COLUMN CONNECTION DETAIL

SCALE: NTS

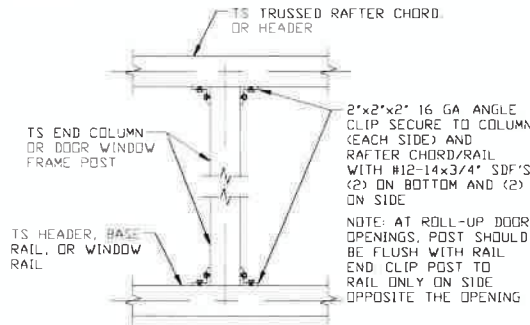

7

COLUMN TO HEADER, BASE RAIL, OR WINDOW RAIL CONNECTION DETAIL

SCALE: NTS

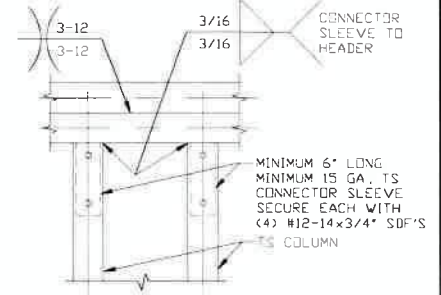

8

DOUBLE HEADER/COLUMN CONNECTION DETAIL

SCALE: NTS

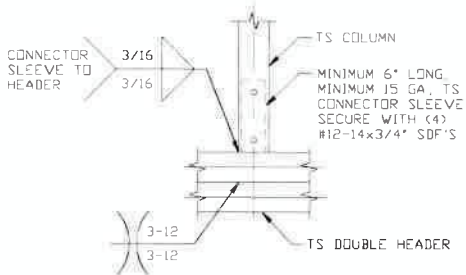

9

COLUMN/DOUBLE HEADER CONNECTION DETAIL

SCALE: NTS



This item has been electronically signed and sealed by Wayne S. Moore, PE, using a Digital Signature and date.

Printed copies of this document are not considered signed and sealed and the signature must be verified on any electronic copies.

**MOORE AND ASSOCIATES
ENGINEERING AND CONSULTING, INC.**

DRAWN BY: JG

CHECKED BY: PDH

PROJECT MGR: WSM

CLIENT: TBS

TUBULAR BUILDING SYSTEMS
631 SE INDUSTRIAL CIRCLE
LAKE CITY, FLORIDA 32025
30'-0" x 20'-0" UTILITY BUILDING EXP. B

DATE: 7-29-21

SHT. 12

SCALE: NTS

DWG. NO: SK-2

JOB NO: 16154S/
17300S/20352S

REV: 3

THIS DOCUMENT IS THE PROPERTY OF MOORE AND ASSOCIATES ENGINEERING AND CONSULTING. THE UNAUTHORIZED REPRODUCTION, COPYING, OR OTHERWISE USE OF THIS DOCUMENT IS STRICTLY PROHIBITED AND ANY INFRINGEMENT THEREUPON MAY BE SUBJECT TO LEGAL ACTION.

CONNECTION DETAILS

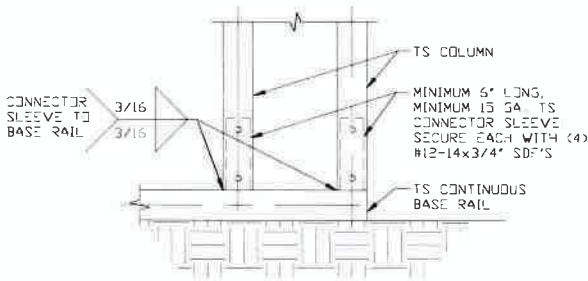

10

COLUMN/BASE RAIL CONNECTION DETAIL

SCALE: NTS

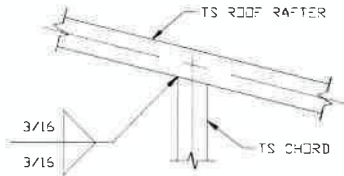

11

RAFTER TO CHORD CONNECTION DETAIL

SCALE: NTS

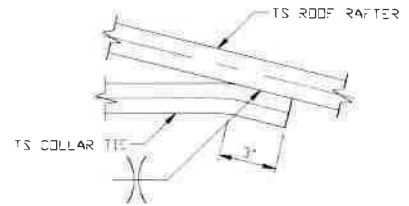

12

COLLAR TIE CONNECTION DETAIL

SCALE: NTS

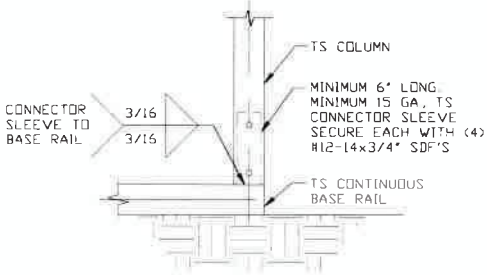

13

COLUMN/BASE RAIL CONNECTION DETAIL

SCALE: NTS

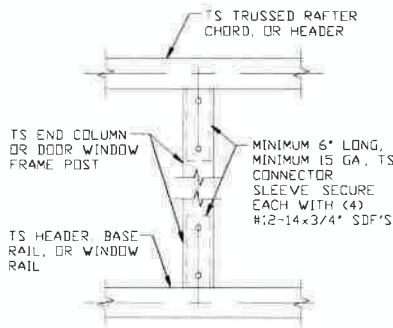

14

COLUMN TO HEADER, BASE RAIL CONNECTION DETAIL

SCALE: NTS



This item has been electronically signed and sealed by Wayne S. Moore, PE, using a Digital Signature and date.

Printed copies of this document are not considered signed and sealed and the signature must be verified on any electronic copies.

**MOORE AND ASSOCIATES
ENGINEERING AND CONSULTING, INC.**

DRAWN BY: JG

CHECKED BY: PDH

PROJECT MGR: WSM

CLIENT: TBS

TUBULAR BUILDING SYSTEMS
631 SE INDUSTRIAL CIRCLE
LAKE CITY, FLORIDA 32025
30'-0" x 20'-0" UTILITY BUILDING EXP. B

DATE: 7-29-21

SCALE: NTS

JOB NO: 16154S/
17300S/20352S

SHT. 13

DWG. NO: SK-2

REV: 3

THIS DOCUMENT IS THE PROPERTY OF MOORE AND ASSOCIATES ENGINEERING AND CONSULTING. THE UNAUTHORIZED REPRODUCTION, COPYING, OR OTHERWISE USE OF THIS DOCUMENT IS STRICTLY PROHIBITED AND ANY INFRINGEMENT THEREUPON MAY BE SUBJECT TO LEGAL ACTION.

BOX EAVE RAFTER LEAN-TO OPTIONS

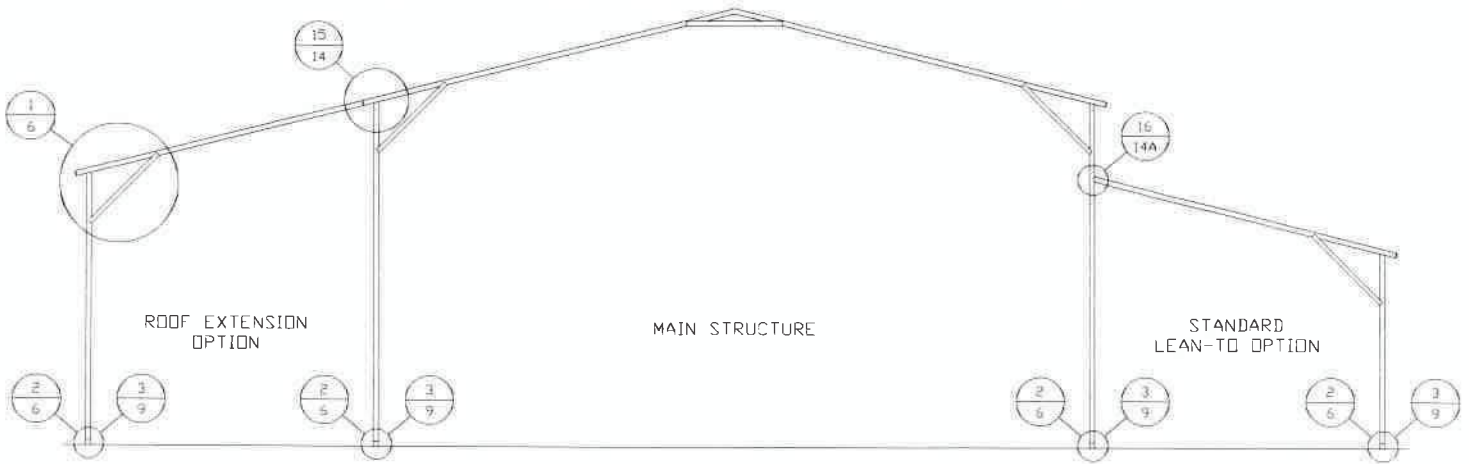

TYPICAL BOX EAVE RAFTER LEAN-TO OPTIONS FRAMING SECTION (BOTH OPTIONS SHOWN)

SCALE: NTS

MAIN BUILDING COLUMNS WITH LEAN-TO OR ROOF EXTENSION ATTACHED ARE REQUIRED TO BE LACED COLUMNS FOR EAVE HEIGHTS 16'-0" < TO < 20'-0"

MAIN BUILDING COLUMNS WITH LEAN-TO OR ROOF EXTENSION ATTACHED ARE REQUIRED TO BE DOUBLE COLUMNS FOR EAVE HEIGHTS 13'-0" (12'-0" FOR HIGH WIND) < TO < 16'-0"

MAIN BUILDING COLUMNS WITH LEAN-TO OR ROOF EXTENSION ATTACHED ARE REQUIRED TO BE SINGLE COLUMNS FOR EAVE HEIGHTS 10'-0" < TO < 13'-0" (12'-0" FOR HIGH WIND) (WITH 4'-4" INSERT)

MAIN BUILDING COLUMNS WITH LEAN-TO OR ROOF EXTENSION ATTACHED ARE REQUIRED TO BE SINGLE COLUMNS FOR EAVE HEIGHTS < 10'-0"

MAINTENANCE COLUMNS WITH LEAN-TO OR ROOF EXTENSION ATTACHED ARE REQUIRED TO BE SINGLE COLUMNS FOR EAVE HEIGHTS < 10'-0"

MAINTENANCE COLUMNS WITH LEAN-TO OR ROOF EXTENSION ATTACHED ARE REQUIRED TO BE SINGLE COLUMNS FOR EAVE HEIGHTS < 10'-0"

MAINTENANCE COLUMNS WITH LEAN-TO OR ROOF EXTENSION ATTACHED ARE REQUIRED TO BE SINGLE COLUMNS FOR EAVE HEIGHTS < 10'-0"

MAINTENANCE COLUMNS WITH LEAN-TO OR ROOF EXTENSION ATTACHED ARE REQUIRED TO BE SINGLE COLUMNS FOR EAVE HEIGHTS < 10'-0"

MAINTENANCE COLUMNS WITH LEAN-TO OR ROOF EXTENSION ATTACHED ARE REQUIRED TO BE SINGLE COLUMNS FOR EAVE HEIGHTS < 10'-0"

MAINTENANCE COLUMNS WITH LEAN-TO OR ROOF EXTENSION ATTACHED ARE REQUIRED TO BE SINGLE COLUMNS FOR EAVE HEIGHTS < 10'-0"

MAINTENANCE COLUMNS WITH LEAN-TO OR ROOF EXTENSION ATTACHED ARE REQUIRED TO BE SINGLE COLUMNS FOR EAVE HEIGHTS < 10'-0"

MAINTENANCE COLUMNS WITH LEAN-TO OR ROOF EXTENSION ATTACHED ARE REQUIRED TO BE SINGLE COLUMNS FOR EAVE HEIGHTS < 10'-0"

MAINTENANCE COLUMNS WITH LEAN-TO OR ROOF EXTENSION ATTACHED ARE REQUIRED TO BE SINGLE COLUMNS FOR EAVE HEIGHTS < 10'-0"

MAINTENANCE COLUMNS WITH LEAN-TO OR ROOF EXTENSION ATTACHED ARE REQUIRED TO BE SINGLE COLUMNS FOR EAVE HEIGHTS < 10'-0"

MAINTENANCE COLUMNS WITH LEAN-TO OR ROOF EXTENSION ATTACHED ARE REQUIRED TO BE SINGLE COLUMNS FOR EAVE HEIGHTS < 10'-0"

MAINTENANCE COLUMNS WITH LEAN-TO OR ROOF EXTENSION ATTACHED ARE REQUIRED TO BE SINGLE COLUMNS FOR EAVE HEIGHTS < 10'-0"

MAINTENANCE COLUMNS WITH LEAN-TO OR ROOF EXTENSION ATTACHED ARE REQUIRED TO BE SINGLE COLUMNS FOR EAVE HEIGHTS < 10'-0"

MAINTENANCE COLUMNS WITH LEAN-TO OR ROOF EXTENSION ATTACHED ARE REQUIRED TO BE SINGLE COLUMNS FOR EAVE HEIGHTS < 10'-0"

MAINTENANCE COLUMNS WITH LEAN-TO OR ROOF EXTENSION ATTACHED ARE REQUIRED TO BE SINGLE COLUMNS FOR EAVE HEIGHTS < 10'-0"

MAINTENANCE COLUMNS WITH LEAN-TO OR ROOF EXTENSION ATTACHED ARE REQUIRED TO BE SINGLE COLUMNS FOR EAVE HEIGHTS < 10'-0"

MAINTENANCE COLUMNS WITH LEAN-TO OR ROOF EXTENSION ATTACHED ARE REQUIRED TO BE SINGLE COLUMNS FOR EAVE HEIGHTS < 10'-0"

MAINTENANCE COLUMNS WITH LEAN-TO OR ROOF EXTENSION ATTACHED ARE REQUIRED TO BE SINGLE COLUMNS FOR EAVE HEIGHTS < 10'-0"

MAINTENANCE COLUMNS WITH LEAN-TO OR ROOF EXTENSION ATTACHED ARE REQUIRED TO BE SINGLE COLUMNS FOR EAVE HEIGHTS < 10'-0"

MAINTENANCE COLUMNS WITH LEAN-TO OR ROOF EXTENSION ATTACHED ARE REQUIRED TO BE SINGLE COLUMNS FOR EAVE HEIGHTS < 10'-0"

MAINTENANCE COLUMNS WITH LEAN-TO OR ROOF EXTENSION ATTACHED ARE REQUIRED TO BE SINGLE COLUMNS FOR EAVE HEIGHTS < 10'-0"

MAINTENANCE COLUMNS WITH LEAN-TO OR ROOF EXTENSION ATTACHED ARE REQUIRED TO BE SINGLE COLUMNS FOR EAVE HEIGHTS < 10'-0"

MAINTENANCE COLUMNS WITH LEAN-TO OR ROOF EXTENSION ATTACHED ARE REQUIRED TO BE SINGLE COLUMNS FOR EAVE HEIGHTS < 10'-0"

MAINTENANCE COLUMNS WITH LEAN-TO OR ROOF EXTENSION ATTACHED ARE REQUIRED TO BE SINGLE COLUMNS FOR EAVE HEIGHTS < 10'-0"

MAINTENANCE COLUMNS WITH LEAN-TO OR ROOF EXTENSION ATTACHED ARE REQUIRED TO BE SINGLE COLUMNS FOR EAVE HEIGHTS < 10'-0"

MAINTENANCE COLUMNS WITH LEAN-TO OR ROOF EXTENSION ATTACHED ARE REQUIRED TO BE SINGLE COLUMNS FOR EAVE HEIGHTS < 10'-0"

MAINTENANCE COLUMNS WITH LEAN-TO OR ROOF EXTENSION ATTACHED ARE REQUIRED TO BE SINGLE COLUMNS FOR EAVE HEIGHTS < 10'-0"

MAINTENANCE COLUMNS WITH LEAN-TO OR ROOF EXTENSION ATTACHED ARE REQUIRED TO BE SINGLE COLUMNS FOR EAVE HEIGHTS < 10'-0"

MAINTENANCE COLUMNS WITH LEAN-TO OR ROOF EXTENSION ATTACHED ARE REQUIRED TO BE SINGLE COLUMNS FOR EAVE HEIGHTS < 10'-0"

MAINTENANCE COLUMNS WITH LEAN-TO OR ROOF EXTENSION ATTACHED ARE REQUIRED TO BE SINGLE COLUMNS FOR EAVE HEIGHTS < 10'-0"

MAINTENANCE COLUMNS WITH LEAN-TO OR ROOF EXTENSION ATTACHED ARE REQUIRED TO BE SINGLE COLUMNS FOR EAVE HEIGHTS < 10'-0"

MAINTENANCE COLUMNS WITH LEAN-TO OR ROOF EXTENSION ATTACHED ARE REQUIRED TO BE SINGLE COLUMNS FOR EAVE HEIGHTS < 10'-0"

MAINTENANCE COLUMNS WITH LEAN-TO OR ROOF EXTENSION ATTACHED ARE REQUIRED TO BE SINGLE COLUMNS FOR EAVE HEIGHTS < 10'-0"

MAINTENANCE COLUMNS WITH LEAN-TO OR ROOF EXTENSION ATTACHED ARE REQUIRED TO BE SINGLE COLUMNS FOR EAVE HEIGHTS < 10'-0"

MAINTENANCE COLUMNS WITH LEAN-TO OR ROOF EXTENSION ATTACHED ARE REQUIRED TO BE SINGLE COLUMNS FOR EAVE HEIGHTS < 10'-0"

MAINTENANCE COLUMNS WITH LEAN-TO OR ROOF EXTENSION ATTACHED ARE REQUIRED TO BE SINGLE COLUMNS FOR EAVE HEIGHTS < 10'-0"

MAINTENANCE COLUMNS WITH LEAN-TO OR ROOF EXTENSION ATTACHED ARE REQUIRED TO BE SINGLE COLUMNS FOR EAVE HEIGHTS < 10'-0"

MAINTENANCE COLUMNS WITH LEAN-TO OR ROOF EXTENSION ATTACHED ARE REQUIRED TO BE SINGLE COLUMNS FOR EAVE HEIGHTS < 10'-0"

MAINTENANCE COLUMNS WITH LEAN-TO OR ROOF EXTENSION ATTACHED ARE REQUIRED TO BE SINGLE COLUMNS FOR EAVE HEIGHTS < 10'-0"

MAINTENANCE COLUMNS WITH LEAN-TO OR ROOF EXTENSION ATTACHED ARE REQUIRED TO BE SINGLE COLUMNS FOR EAVE HEIGHTS < 10'-0"

MAINTENANCE COLUMNS WITH LEAN-TO OR ROOF EXTENSION ATTACHED ARE REQUIRED TO BE SINGLE COLUMNS FOR EAVE HEIGHTS < 10'-0"

MAINTENANCE COLUMNS WITH LEAN-TO OR ROOF EXTENSION ATTACHED ARE REQUIRED TO BE SINGLE COLUMNS FOR EAVE HEIGHTS < 10'-0"

MAINTENANCE COLUMNS WITH LEAN-TO OR ROOF EXTENSION ATTACHED ARE REQUIRED TO BE SINGLE COLUMNS FOR EAVE HEIGHTS < 10'-0"

MAINTENANCE COLUMNS WITH LEAN-TO OR ROOF EXTENSION ATTACHED ARE REQUIRED TO BE SINGLE COLUMNS FOR EAVE HEIGHTS < 10'-0"

MAINTENANCE COLUMNS WITH LEAN-TO OR ROOF EXTENSION ATTACHED ARE REQUIRED TO BE SINGLE COLUMNS FOR EAVE HEIGHTS < 10'-0"

MAINTENANCE COLUMNS WITH LEAN-TO OR ROOF EXTENSION ATTACHED ARE REQUIRED TO BE SINGLE COLUMNS FOR EAVE HEIGHTS < 10'-0"

MAINTENANCE COLUMNS WITH LEAN-TO OR ROOF EXTENSION ATTACHED ARE REQUIRED TO BE SINGLE COLUMNS FOR EAVE HEIGHTS < 10'-0"

MAINTENANCE COLUMNS WITH LEAN-TO OR ROOF EXTENSION ATTACHED ARE REQUIRED TO BE SINGLE COLUMNS FOR EAVE HEIGHTS < 10'-0"

MAINTENANCE COLUMNS WITH LEAN-TO OR ROOF EXTENSION ATTACHED ARE REQUIRED TO BE SINGLE COLUMNS FOR EAVE HEIGHTS < 10'-0"

MAINTENANCE COLUMNS WITH LEAN-TO OR ROOF EXTENSION ATTACHED ARE REQUIRED TO BE SINGLE COLUMNS FOR EAVE HEIGHTS < 10'-0"

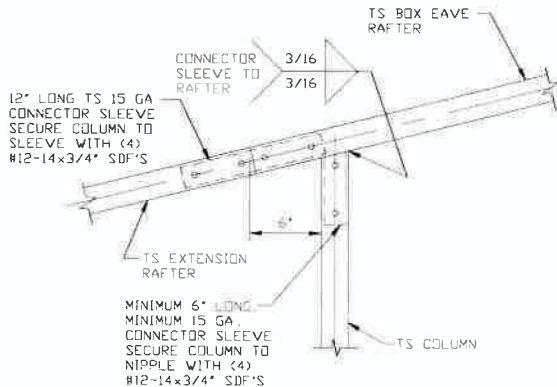

15

SIDE EXTENSION RAFTER/COLUMN DETAIL FOR RAFTER SPANS <= 15'-0"

SCALE: NTS

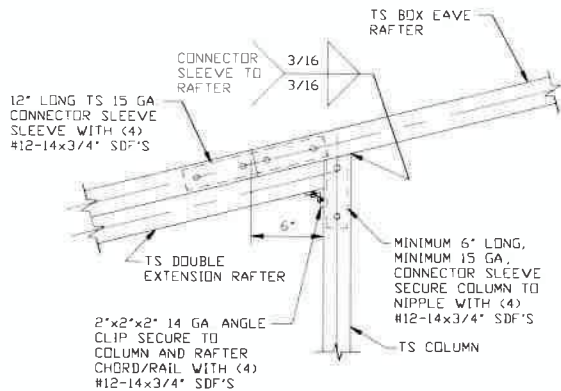

15A

SIDE EXTENSION RAFTER/COLUMN DETAIL FOR RAFTER SPANS 15'-0" < TO <= 24'-0"

SCALE: NTS



This item has been electronically signed and sealed by Wayne S. Moore, PE, using a Digital Signature and date.

Printed copies of this document are not considered signed and sealed and the signature must be verified on any electronic copies.

**MOORE AND ASSOCIATES
ENGINEERING AND CONSULTING, INC.**

DRAWN BY: JG

CHECKED BY: PDH

PROJECT MGR: WSM

CLIENT: TBS

TUBULAR BUILDING SYSTEMS
631 SE INDUSTRIAL CIRCLE
LAKE CITY, FLORIDA 32025
30'-0"x20'-0" UTILITY BUILDING EXP. B

DATE: 7-29-21

SHT. 14

SCALE: NTS

DWG. NO: SK-2

JOB NO: 16154S/
17300S/20352S

REV: 3

THIS DOCUMENT IS THE PROPERTY OF MOORE AND ASSOCIATES ENGINEERING AND CONSULTING. THE UNAUTHORIZED REPRODUCTION, COPYING, OR OTHERWISE USE OF THIS DOCUMENT IS STRICTLY PROHIBITED AND ANY INFRINGEMENT THEREUPON MAY BE SUBJECT TO LEGAL ACTION.

BOX EAVE RAFTER LEAN-TO OPTIONS

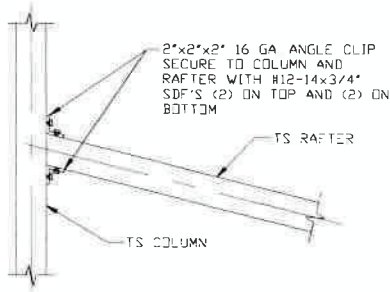

**LEAN-TO RAFTER TO RAFTER
COLUMN CONNECTION DETAIL
FOR RAFTER SPANS $\leq 15'-0''$**

16

SCALE: NTS

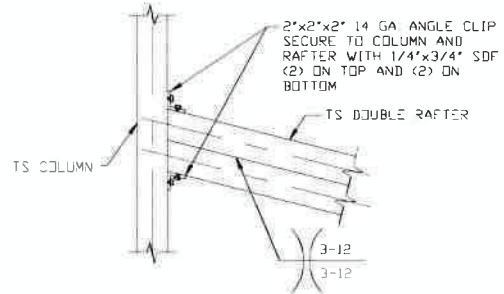

**LEAN-TO RAFTER TO RAFTER
COLUMN CONNECTION DETAIL
FOR RAFTER SPANS
 $15'-0'' < TO \leq 24'-0''$**

16A

SCALE: NTS



This item has been electronically signed and sealed by Wayne S. Moore, PE. using a Digital Signature and date.

Printed copies of this document are not considered signed and sealed and the signature must be verified on any electronic copies.

**MOORE AND ASSOCIATES
ENGINEERING AND CONSULTING, INC.**

DRAWN BY: JG

CHECKED BY: PDH

PROJECT MGR: WSM

CLIENT: TBS

**TUBULAR BUILDING SYSTEMS
631 SE INDUSTRIAL CIRCLE
LAKE CITY, FLORIDA 32025
30'-0"x20'-0" UTILITY BUILDING EXP. B**

DATE: 7-29-21

SCALE: NTS

**JOB NO: 16154S/
17300S/20352S**

SHT. 14A

DWG. NO: SK-2

REV: 3

THIS DOCUMENT IS THE PROPERTY OF MOORE AND ASSOCIATES ENGINEERING AND CONSULTING. THE UNAUTHORIZED REPRODUCTION, COPYING, OR OTHERWISE USE OF THIS DOCUMENT IS STRICTLY PROHIBITED AND ANY INFRINGEMENT THEREUPON MAY BE SUBJECT TO LEGAL ACTION.

BOW RAFTER LEAN-TO OPTIONS

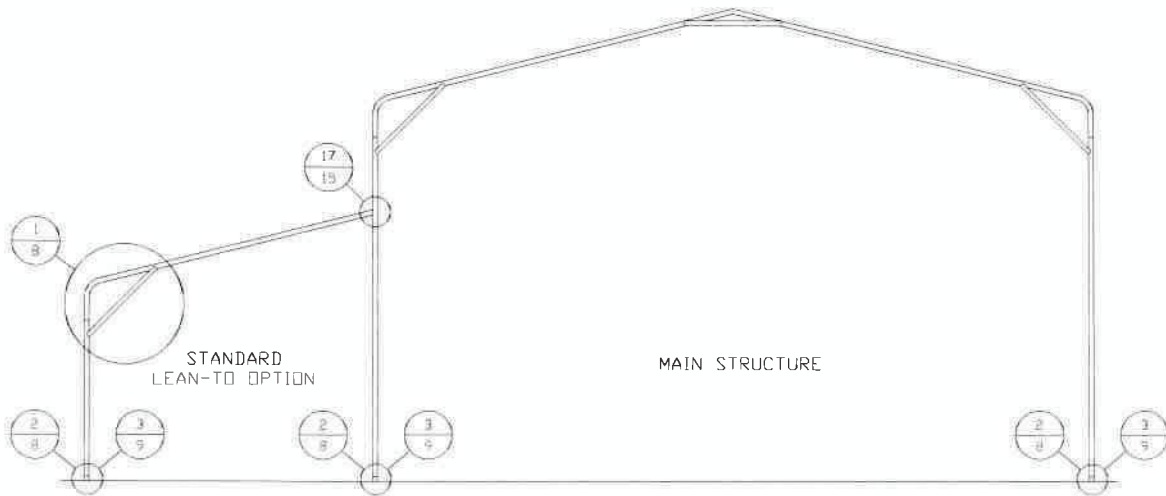

TYPICAL BOW RAFTER LEAN-TO OPTIONS FRAMING SECTION (BOTH OPTIONS SHOWN)

SCALE: NTS

MAIN BUILDING COLUMNS WITH LEAN-TO OR ROOF EXTENSION ATTACHED ARE REQUIRED TO BE DOUBLE COLUMNS FOR EAVE HEIGHTS 13'-0" (12'-0" FOR HIGH WIND) < TO < 15'-0"

MAIN BUILDING COLUMNS WITH LEAN-TO OR ROOF EXTENSION ATTACHED ARE REQUIRED TO BE SINGLE COLUMNS FOR EAVE HEIGHTS 10'-0" < TO < 13'-0" (12'-0" FOR HIGH WIND) (WITH 4'-4" INSERT)

MAIN BUILDING COLUMNS WITH LEAN-TO OR ROOF EXTENSION ATTACHED ARE REQUIRED TO BE SINGLE COLUMNS FOR EAVE HEIGHTS < 10'-0"

KNEE BRACES MUST BE 4'-0" (5'-0" FOR HIGH WIND) WHEN LEAN-TO'S ARE ADDED

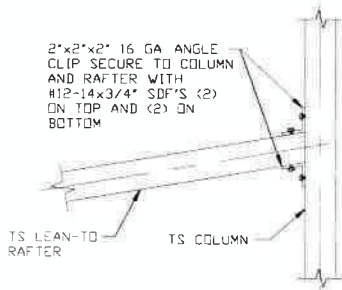

LEAN-TO RAFTER TO RAFTER COLUMN CONNECTION DETAIL FOR RAFTER SPANS $\leq 15'-0''$

17

SCALE: NTS

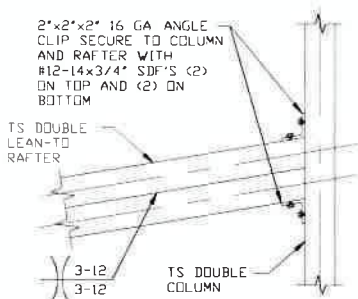

LEAN-TO RAFTER TO RAFTER COLUMN CONNECTION DETAIL FOR RAFTER SPANS 15'-0" < TO <= 24'-0"

17A

SCALE: NTS



This item has been electronically signed and sealed by Wayne S. Moore, PE, using a Digital Signature and date.

Printed copies of this document are not considered signed and sealed and the signature must be verified on any electronic copies.

**MOORE AND ASSOCIATES
ENGINEERING AND CONSULTING, INC.**

DRAWN BY: JG

CHECKED BY: PDH

PROJECT MGR: WSM

CLIENT: TBS

TUBULAR BUILDING SYSTEMS
631 SE INDUSTRIAL CIRCLE
LAKE CITY, FLORIDA 32025
30'-0"x20'-0" UTILITY BUILDING EXP. B

DATE: 7-29-21

SHT. 15

SCALE: NTS

DWG. NO: SK-2

JOB NO: 16154S/
17300S/20352S

REV: 3

THIS DOCUMENT IS THE PROPERTY OF MOORE AND ASSOCIATES ENGINEERING AND CONSULTING. THE UNAUTHORIZED REPRODUCTION, COPYING, OR OTHERWISE USE OF THIS DOCUMENT IS STRICTLY PROHIBITED AND ANY INFRINGEMENT THEREUPON MAY BE SUBJECT TO LEGAL ACTION.

BOX EAVE RAFTER VERTICAL ROOF/SIDING OPTION

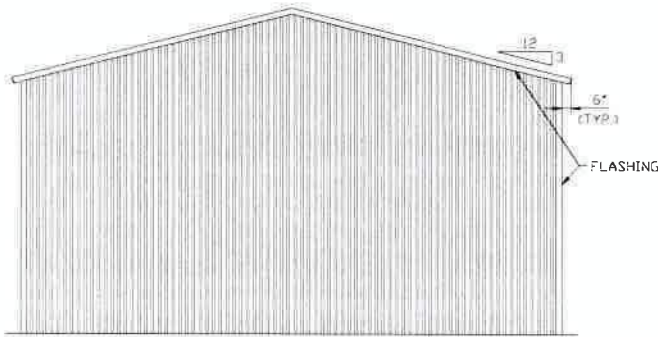

**TYPICAL END ELEVATION
VERTICAL ROOF/SIDING OPTION**

SCALE: NTS

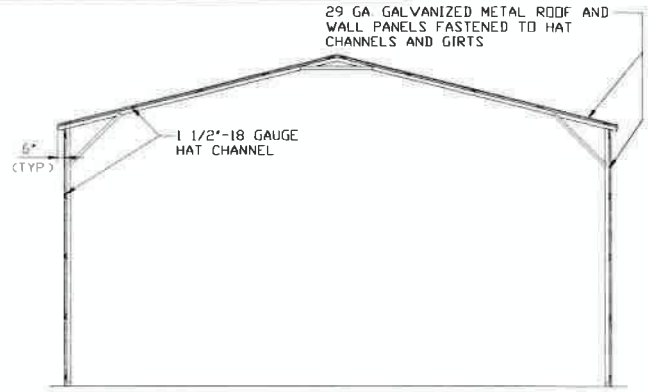

**TYPICAL SECTION VERTICAL
ROOF/SIDING OPTION**

SCALE: NTS

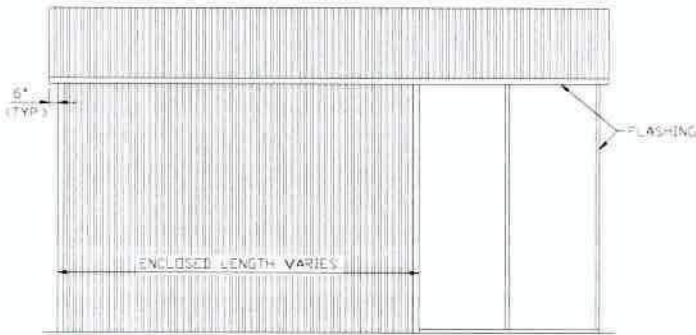

**TYPICAL SIDE ELEVATION
VERTICAL ROOF/SIDING OPTION**

SCALE: NTS

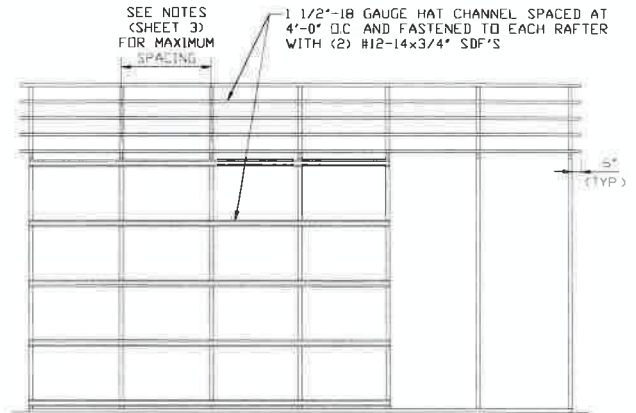

**TYPICAL FRAMING SECTION
VERTICAL ROOF/SIDING OPTION**

SCALE: NTS

NOTE: TS WALL GIRTS CAN BE USED AS AN OPTION IN PLACE OF HAT CHANNELS TS GIRTS MUST BE SPACD AT 4'-0" (MAX) OC

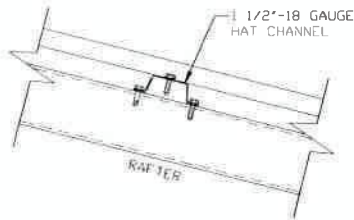

ROOF PANEL ATTACHMENT

(ALTERNATE FOR VERTICAL ROOF PANELS)
SCALE: NTS



This item has been electronically signed and sealed by Wayne S. Moore, PE, using a Digital Signature and date.

Printed copies of this document are not considered signed and sealed and the signature must be verified on any electronic copies.

**MOORE AND ASSOCIATES
ENGINEERING AND CONSULTING, INC.**

DRAWN BY: JG

CHECKED BY: PDH

PROJECT MGR: WSM

CLIENT: TBS

TUBULAR BUILDING SYSTEMS
631 SE INDUSTRIAL CIRCLE
LAKE CITY, FLORIDA 32025
30'-0" x 20'-0" UTILITY BUILDING EXP. B

DATE: 7-29-21

SHT. 16

SCALE: NTS

DWG. NO: SK-2

**JOB NO: 16154S/
17300S/20352S**

REV: 3

THIS DOCUMENT IS THE PROPERTY OF MOORE AND ASSOCIATES ENGINEERING AND CONSULTING. THE UNAUTHORIZED REPRODUCTION, COPYING, OR OTHERWISE USE OF THIS DOCUMENT IS STRICTLY PROHIBITED AND ANY INFRINGEMENT THEREUPON MAY BE SUBJECT TO LEGAL ACTION.

SIDE WALL HEADER OPTIONS

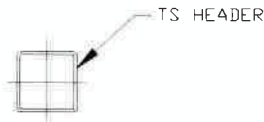

**HEADER DETAIL FOR DOOR
OPENINGS $\leq 10'-0"$**

SCALE: NTS

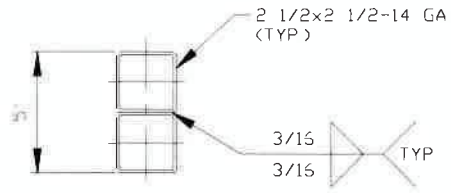

**HEADER DETAIL FOR DOOR
OPENINGS $10'-0" < \text{LENGTH} \leq 15'-0"$**

SCALE: NTS

END WALL HEADER OPTIONS

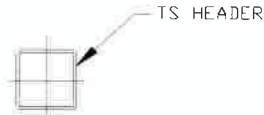

**HEADER DETAIL FOR DOOR
OPENINGS $\leq 12'-0"$**

SCALE: NTS

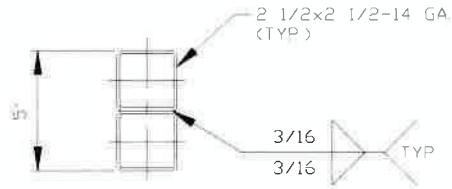

**HEADER DETAIL FOR DOOR
OPENINGS $12'-0" < \text{LENGTH} \leq 15'-0"$**

SCALE: NTS



This item has been electronically signed and sealed by Wayne S. Moore, PE, using a Digital Signature and date.

Printed copies of this document are not considered signed and sealed and the signature must be verified on any electronic copies.

**MOORE AND ASSOCIATES
ENGINEERING AND CONSULTING, INC.**

DRAWN BY: JG

CHECKED BY: PDH

PROJECT MGR: WSM

CLIENT: TBS

TUBULAR BUILDING SYSTEMS
631 SE INDUSTRIAL CIRCLE
LAKE CITY, FLORIDA 32025
30'-0"x20'-0" UTILITY BUILDING EXP. B

DATE: 7-29-21

SCALE: NTS

JOB NO: 16154S/
17300S/20352S

SHT. 17

DWG. NO: SK-2

REV: 3

THIS DOCUMENT IS THE PROPERTY OF MOORE AND ASSOCIATES ENGINEERING AND CONSULTING. THE UNAUTHORIZED REPRODUCTION, COPYING, OR OTHERWISE USE OF THIS DOCUMENT IS STRICTLY PROHIBITED AND ANY INFRINGEMENT THEREUPON MAY BE SUBJECT TO LEGAL ACTION.

FLOOD VENT DETAIL

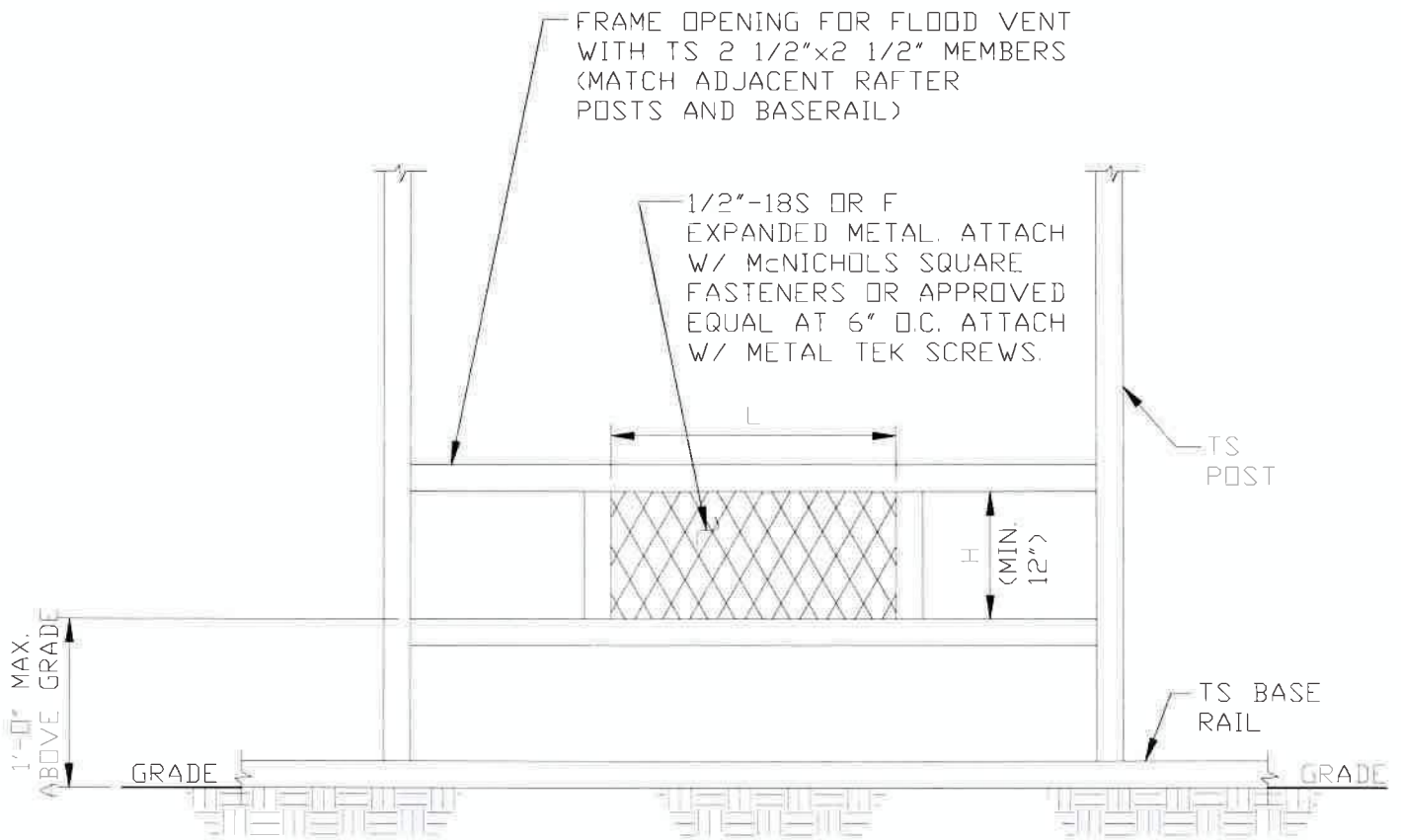

TYPICAL FLOOD VENT DETAIL

SCALE: NTS

- 1 MINIMUM VENT SPACE REQUIRED = 1 SQ. INCH OF OPEN VENT AREA PER SQ. FOOT OF BUILDING AREA
- 2 THERE SHALL BE A MINIMUM OF TWO OPENINGS ON DIFFERENT SIDES FOR EACH ENCLOSED BUILDING
- 3 APPLY 13 FACTOR WHEN CALCULATING TOTAL OPEN AREA WHEN USING 1/2"-18GA S OR F EXPANDED METAL.
- 4 TOTAL OPEN AREA OF VENT = $L \times H (\text{MIN } 12")$
- 5 FLOOD VENT DETAIL COMPLIES WITH FEMA/NFIP
- 6 PREFABRICATED FLOOD VENTS MEETING THE REQUIREMENTS OF FEMA/NIFIP MAY BE USED



This item has been electronically signed and sealed by Wayne S. Moore, PE. using a Digital Signature and date.

Printed copies of this document are not considered signed and sealed and the signature must be verified on any electronic copies.

**MOORE AND ASSOCIATES
ENGINEERING AND CONSULTING, INC.**

DRAWN BY: JG

CHECKED BY: PDH

PROJECT MGR: WSM

CLIENT: TBS

TUBULAR BUILDING SYSTEMS
631 SE INDUSTRIAL CIRCLE
LAKE CITY, FLORIDA 32025
30'-0" x 20'-0" UTILITY BUILDING EXP. B

DATE: 7-29-21

SHT. 18

SCALE: NTS

DWG. NO: SK-2

JOB NO: 16154S/
17300S/20352S

REV: 3

THIS DOCUMENT IS THE PROPERTY OF MOORE AND ASSOCIATES ENGINEERING AND CONSULTING. THE UNAUTHORIZED REPRODUCTION, COPYING, OR OTHERWISE USE OF THIS DOCUMENT IS STRICTLY PROHIBITED AND ANY INFRINGEMENT THEREUPON MAY BE SUBJECT TO LEGAL ACTION.

STAND-ALONE STEM WALL DETAIL

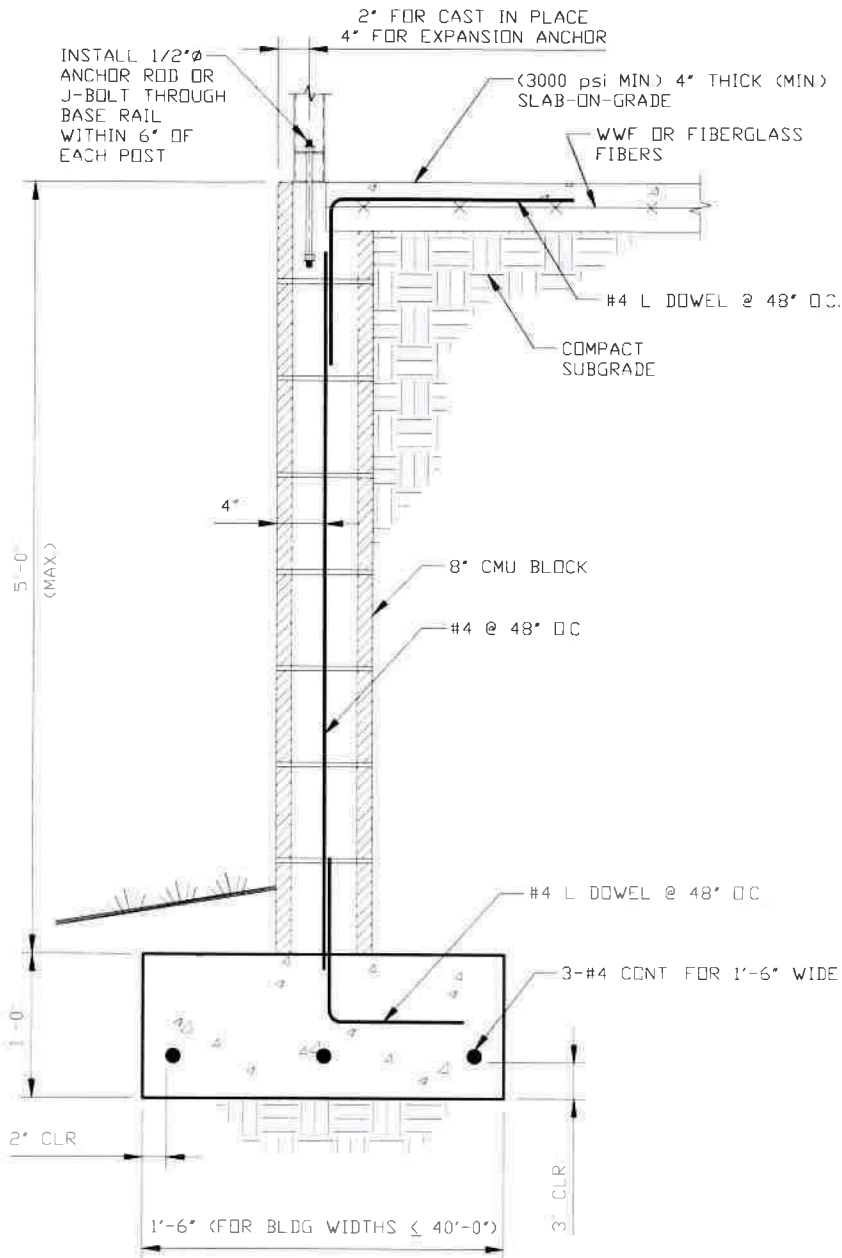

**STAND-ALONE CONCRETE MASONRY UNIT (CMU)
FOUNDATION STEM WALL DETAIL**

SCALE: NTS



This item has been electronically signed and sealed by Wayne S. Moore, PE, using a Digital Signature and date.

Printed copies of this document are not considered signed and sealed and the signature must be verified on any electronic copies.

**MOORE AND ASSOCIATES
ENGINEERING AND CONSULTING, INC.**

DRAWN BY: JG

CHECKED BY: PDH

PROJECT MGR: WSM

CLIENT: TBS

**TUBULAR BUILDING SYSTEMS
631 SE INDUSTRIAL CIRCLE
LAKE CITY, FLORIDA 32025
30'-0"x20'-0" UTILITY BUILDING EXP. B**

DATE: 7-29-21

SHT. 19

SCALE: NTS

DWG. NO: SK-2

**JOB NO: 16154S/
17300S/20352S**

REV: 3

THIS DOCUMENT IS THE PROPERTY OF MOORE AND ASSOCIATES ENGINEERING AND CONSULTING. THE UNAUTHORIZED REPRODUCTION, COPYING, OR OTHERWISE USE OF THIS DOCUMENT IS STRICTLY PROHIBITED AND ANY INFRINGEMENT THEREUPON MAY BE SUBJECT TO LEGAL ACTION.

VERTICAL SLIDING WINDOW DETAIL

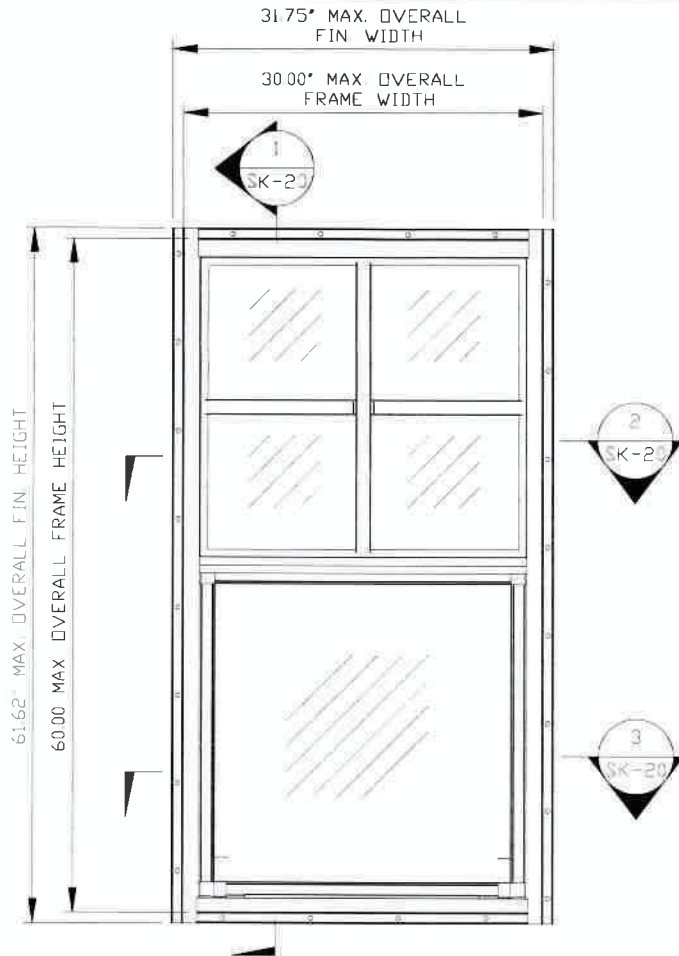

ELEVATION VIEW

SCALE: NTS

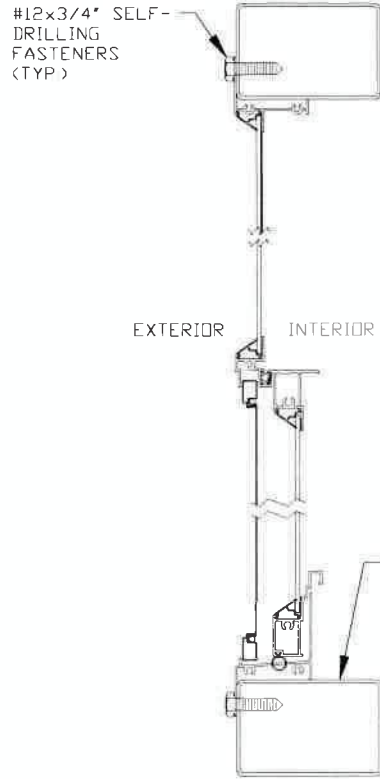

SECTION 1
SCALE: 3"=1'-0" SK-20

NOTE: KINRD SERIES 18000-R VS OR EQUIVALENT WINDOW IS REQUIRED

POSITIVE WALL PRESSURE: +40.0 PSF

NEGATIVE WALL PRESSURE: -40.0 PSF

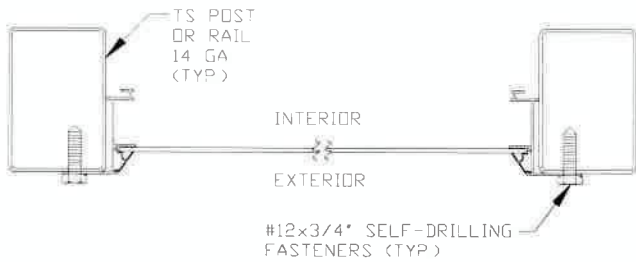

SECTION 2
SCALE: 3"=1'-0" SK-20

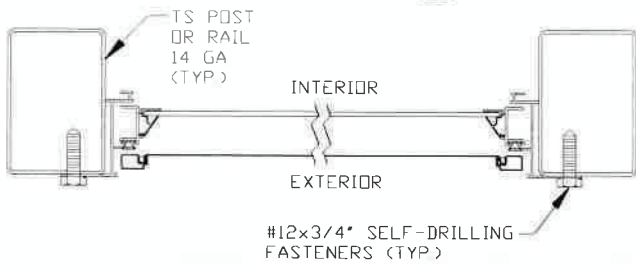

SECTION 3
SCALE: 3"=1'-0" SK-20



This item has been electronically signed and sealed by Wayne S. Moore, PE, using a Digital Signature and date.

Printed copies of this document are not considered signed and sealed and the signature must be verified on any electronic copies.

**MOORE AND ASSOCIATES
ENGINEERING AND CONSULTING, INC.**

DRAWN BY: JG

CHECKED BY: PDH

PROJECT MGR: WSM

CLIENT: TBS

**TUBULAR BUILDING SYSTEMS
631 SE INDUSTRIAL CIRCLE
LAKE CITY, FLORIDA 32025
30'-0" x 20'-0" UTILITY BUILDING EXP. B**

DATE: 7-29-21

SHT. 20

SCALE: NTS

DWG. NO: SK-2

**JOB NO: 16154S/
17300S/20352S**

REV: 3

THIS DOCUMENT IS THE PROPERTY OF MOORE AND ASSOCIATES ENGINEERING AND CONSULTING. THE UNAUTHORIZED REPRODUCTION, COPYING, OR OTHERWISE USE OF THIS DOCUMENT IS STRICTLY PROHIBITED AND ANY INFRINGEMENT THEREUPON MAY BE SUBJECT TO LEGAL ACTION.

OPTIONAL CONCRETE STRIP FOOTING

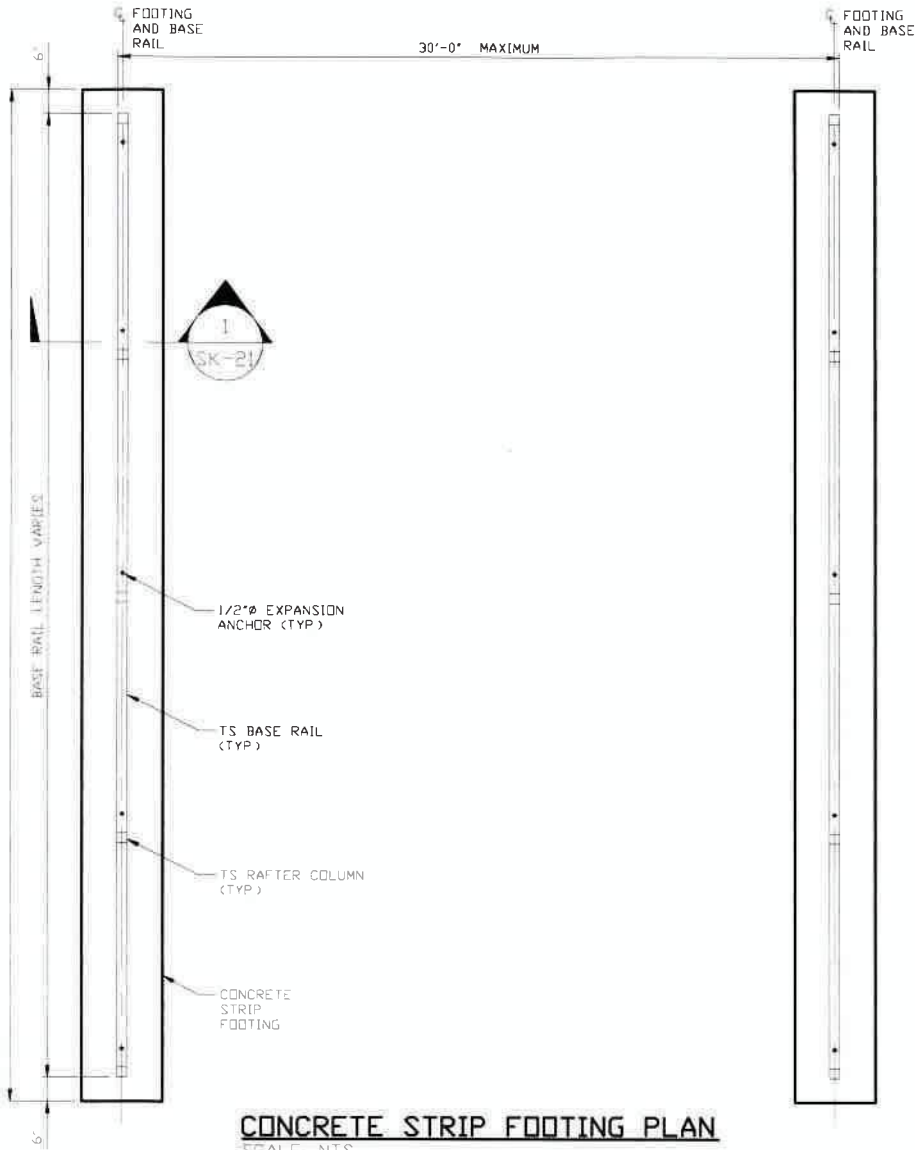

CONCRETE STRIP FOOTING PLAN
SCALE: NTS

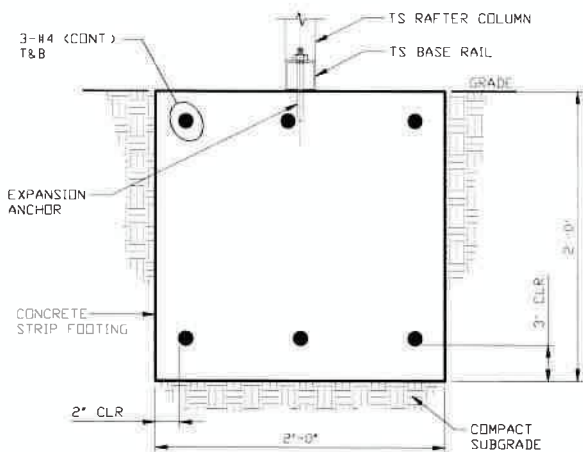

SECTION 1
SCALE: NTS

* COORDINATE WITH LOCAL CODES/ORD

- 1 STRIP FOOTING DESIGN BASED ON MINIMUM SOIL BEARING CAPACITY OF 1,500 PSF
- 2 CONCRETE SHALL HAVE A MINIMUM SPECIFIED COMPRESSIVE STRENGTH OF 3,000 PSI AT 28 DAYS
- 3 FOR FOUNDATIONS, MINIMUM CONCRETE COVER OVER REINFORCING BARS SHALL BE PER ACI-318 3" IN FOUNDATIONS WHERE THE CONCRETE IS CAST AGAINST AND PERMANENTLY IN CONTACT WITH THE EARTH OR EXPOSED TO THE EARTH OR WEATHER, AND 1 1/2" ELSEWHERE
- 4 THE STRIP FOOTING REINFORCING STEEL SHALL BE ASTM A615 GRADE 60
- 5 REINFORCEMENT MAY BE BENT IN THE SHOP OR IN THE FIELD PROVIDED:
 - A) REINFORCEMENT IS BENT COLD
 - B) THE DIAMETER OF THE BEND, MEASURED ON THE INSIDE OF THE BAR, IS NOT LESS THAN SIX-BAR DIAMETERS
 - C) REINFORCEMENT PARTIALLY EMBEDDED IN CONCRETE SHALL NOT BE FIELD BENT



This item has been electronically signed and sealed by Wayne S. Moore, PE, using a Digital Signature and date.

Printed copies of this document are not considered signed and sealed and the signature must be verified on any electronic copies.

**MOORE AND ASSOCIATES
ENGINEERING AND CONSULTING, INC.**

DRAWN BY: JG

CHECKED BY: PDH

PROJECT MGR: WSM

CLIENT: TBS

TUBULAR BUILDING SYSTEMS
631 SE INDUSTRIAL CIRCLE
LAKE CITY, FLORIDA 32025
30'-0" x 20'-0" UTILITY BUILDING EXP. B

DATE: 7-29-21

SCALE: NTS

SHT. 21

DWG. NO: SK-2

JOB NO: 16154S/
17300S/20352S

REV: 3

THIS DOCUMENT IS THE PROPERTY OF MOORE AND ASSOCIATES ENGINEERING AND CONSULTING. THE UNAUTHORIZED REPRODUCTION, COPYING, OR OTHERWISE USE OF THIS DOCUMENT IS STRICTLY PROHIBITED AND ANY INFRINGEMENT THEREUPON MAY BE SUBJECT TO LEGAL ACTION.