

# Cool and Cobb Engineering Company

Job: Geoff Casner

Date: 3/10/2026

Location: 375 SW Minter Rd., Lake City, Fl. 32024

Project: 26-1081

## HELICAL PILE DESIGN

### Design Scope Notes:

1. This design is developed per field assessment and layout provided by licensed foundation contractor. Cool and Cobb Engineering Co. has not performed an on-site assessment of the structure.
2. Location and quantity of supplemental supports has been determined by owner/contractor agreement.
3. The design intent offers supplemental support to stabilize the existing foundation in depicted area(s) only and will reduce the total pressures on existing soils. The structure may require additional stabilization to other affected areas not addressed in this design.
4. This design is based on the estimated load of the structure placed on shallow soils. No deep soils geotechnical testing information was provided for this design.
5. Cool and Cobb is not responsible for on-site engineering evaluations or inspections. If on-site inspection is required, contractor to obtain an approved 3rd party to inspect and provide Cool and Cobb Engineering inspection certification details and report.
6. This design does not address any possible sink hole activity as defined in Florida Statute § 627.706.

### General Notes:

1. Contractor to ensure all piles are installed in accordance with ICC ES AC 358.
2. The first pile installed on site will be considered a test pile. If the minimum psi is not achieved within **25'** or if voids or soft soil conditions are found, the contractor shall stop the installation and notify the engineer, for re-evaluation.
3. In the event stabilization results in any void below foundation, chemical grout should be applied to provide continuous support below concrete foundation and/or slab. Contractor shall use caution as any lift could damage below slab utilities.
4. **At completion of the installation, Cool and Cobb Engineering Co. shall be supplied with a signed and dated Installation Log to include final location, final depth, and installation torque psi of each pile along with any design changes (with reason for field changes), for Engineer approval and completion of the "As Built Certification".**

## LOADING ANALYSIS

The loadings were determined for each pile specifically. The support locations and type are provided in the attached plan. Calculated total loadings, including both dead and live loads are provided in Attachment "A". Based on the total loading requirements, the Digga 12ALS driver is to be used to achieve a minimum gauge pressure of 1,000 psi, which will provide pile capacity, including 2 to 1 safety factor of 37,330 lbs., which is greater than the maximum calculated load of 12,750 lbs. which occurs on pile No. 1. This design is based on a maximum of 8' pile spacing with no piles under windows or door openings. Any piles installed less than 48" apart are to be battered 10° away from each other.

Contractor to certify installation meets above calculated psi by extending 2' past the design pressure, and a minimum pile depth of Ten (10') feet which is certified as meeting the requirements of the Florida Building Code 2023, 8th Edition, and good standard engineering practice.

## POLY (Chemical Grout) DESIGN

The loadings were determined to level/raise/fill the identified areas by applying chemical grout to provide continuous support below concrete foundation and/or slab. The selected injection areas for the application are identified on the Plan attached. The calculated loading of 90 lbs/ ft<sup>2</sup>, is certified as meeting good engineering practice.

3/10/2026

Kenneth F. Wheeler, P.E.

State of Florida

Professional Engineer No. 60417



This item has been digitally signed and sealed by Kenneth F. Wheeler, P.E. on the date adjacent to the seal.

Printed copies of this document are not considered signed and sealed and the signature must be verified on any electronic copies.

Contractor: **Solid Foundations**

203 W. Main St.  
Avon Park, FL 33825  
Office: (863) 657-2323

# Solid Foundations

1910 SW Main Blvd  
 Lake City, FL 32025  
 855-227-0300

www.solidfoundations.com



SF Representative: Jimbo Willis

Cell: (386)288-3240

Email: [Jimmie@solidfoundations.com](mailto:Jimmie@solidfoundations.com)

CONTRACT DATE: 12/1/2025

SUBMITTED TO: Geoff Casner

ADDRESS: 375 SW Minter Rd.

EMAIL: [gcasner59@att.net](mailto:gcasner59@att.net)

Phone: 321-289-5070

1-Story block Home with Stucco and Brick Finish on and Shingle Roof on Conc Foundation.

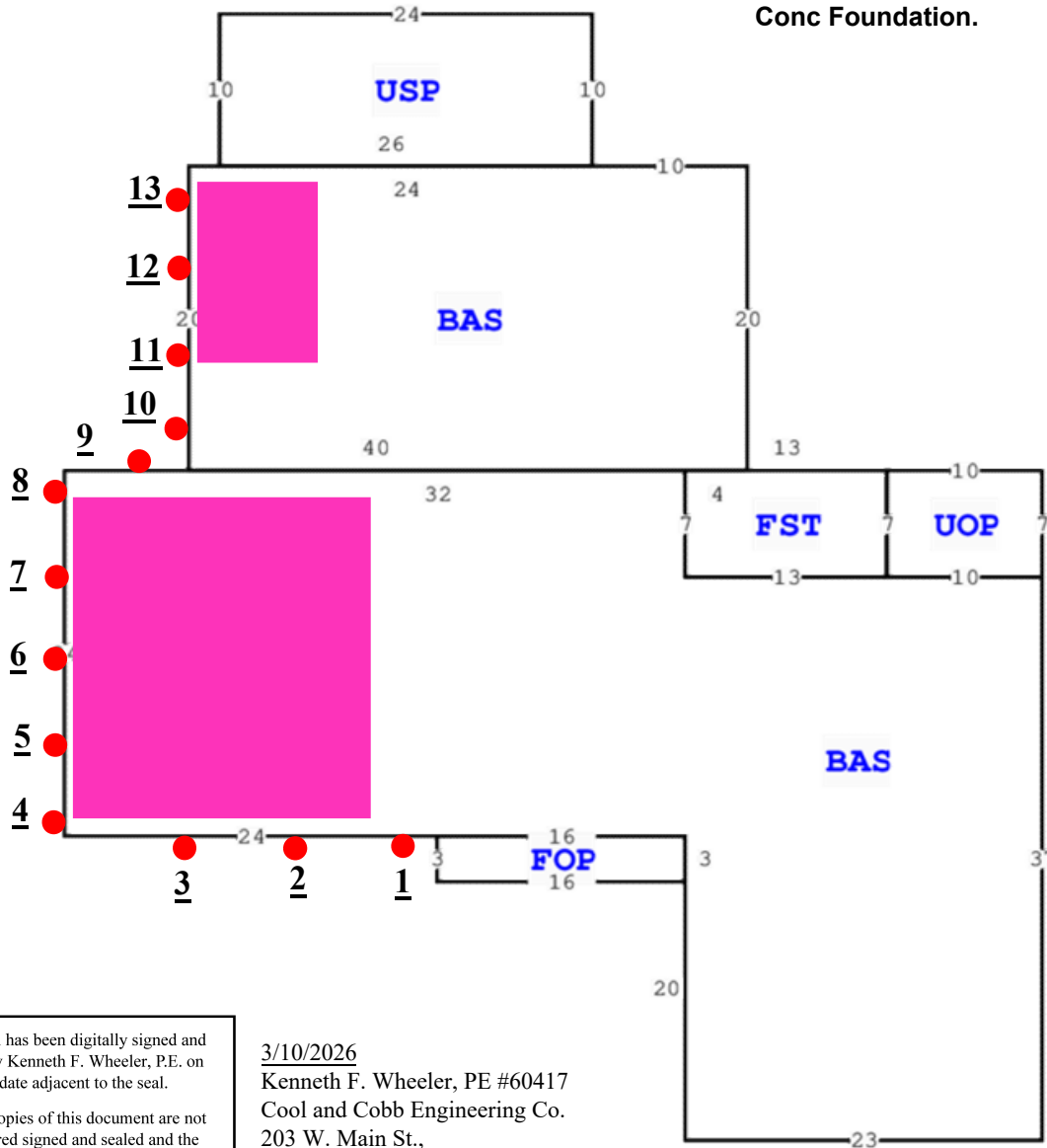

This item has been digitally signed and sealed by Kenneth F. Wheeler, P.E. on the date adjacent to the seal.

Printed copies of this document are not considered signed and sealed and the signature must be verified on any electronic copies.

3/10/2026

Kenneth F. Wheeler, PE #60417  
 Cool and Cobb Engineering Co.  
 203 W. Main St.,  
 Avon Park, FL 33825

CCEC # 26-1081

Push Pier Model 300: ●

Push Pier Model 250: ●

Helical Pier: ●

Crawl Space Pier: ●

Interior Pier: ●

Low Profile Bracket: ●

Porch Bracket: ●

4x6 Wood Beam:

NCFI-24-120

NCFI-24-003

Windows/Doors:

Floor Joist:

# Cool and Cobb Engineering Company

Job: Geoff Casner  
Location: 375 SW Minter Rd., Lake City, Fl. 32024

Date: 3/10/2026  
Project # 26-1081

## Attachment "A"

Total Load on Support (Live Load + Dead Load)

<u>SUPPORT NO.</u>	<u>TOTAL CALCULATE LOAD</u>	
1	12,750	lbs
2	12,000	lbs
3	12,000	lbs
4	9,600	lbs
5	6,000	lbs
6	6,000	lbs
7	6,000	lbs
8	6,600	lbs
9	9,000	lbs
10	7,500	lbs
11	9,000	lbs
12	9,000	lbs
13	9,300	lbs

Maximum Total Load on Pile: 12,750 lbs

3/10/2026  
Kenneth F Wheeler, P.E.  
State of Florida  
Professional Engineer No. 60417

This item has been digitally signed and sealed by Kenneth F. Wheeler, P.E. on the date adjacent to the seal.

Printed copies of this document are not considered signed and sealed and the signature must be verified on any electronic copies.

203 W. Main St.  
Avon Park, FL 33825  
Office: (863) 657-2323

# PLANETARY ANCHOR DRIVES

## 9,000 FT LBS - 12,000 FT LBS



Developed in conjunction with the leading Screw Anchor/Pile installers around the world. The only true Anchor Drives available, designed & manufactured inhouse by Digga, specifically for the rigours of the application. Host machine operates in the most efficient HP range, minimizing wear & tear, to optimize performance & ensure highest returns.

### FEATURES

- High efficiency EATON/DIGGA bell geroler hydraulic motors with integrated Pressure Relief Valve ensures max volumetric efficiency for consistent & efficient pile installation throughout your working day
- More linear feet in the ground = greater returns
- ECV (Energy Control Valve) to prevent rapid decompression of oil, caused by the reverse energy created by Pile Kick-back
- Engineered hood & ears for maximum strength
- Extreme duty shaft retaining system
- No Case Drain required
- 3yr Gearbox & 2yr Motor Warranty



*Need Torque from a lower pressure? No problem.*

Two pressure series are available to suit your requirements.

Standard pressure series, for machines with 3500 PSI. Low Pressure series, for machines with 3000 PSI

### PREMIUM ANCHOR DRIVES

MODEL	STANDARD PRESSURE - 3500 PSI		LOW PRESSURE - 3000 PSI	
	9ADS	12ADS	9ALS	12ALS
Nominal Torque (FT LBS)	9,112	11,542	9,893	12,445
Max Pressure - Do Not Exceed	3500psi @ 29gpm	3500psi @ 29gpm	3000psi @ 29gpm	3000psi @ 29gpm
Max Flow - Do Not Exceed	55gpm @ 1800psi	55gpm @ 1800psi	55gpm @ 1800psi	55gpm @ 1800psi
Max Horse Power	60	60	60	60
Pressure Relief Valve	Included	Included	Included	Included
Energy Control Valve	Included	Included	Included	Included
Standard Output Shaft	2.5" Hex	2.5" Hex	2.5" Hex	2.5" Hex
Weight (lbs)	351	351	351	351
Overall Length (in)	37.2"	37.2"	37.2"	37.2"
Diameter (in)	11.4"	11.4"	11.4"	11.4"

## OPTIONAL EXTRAS

- Ryno Piling cradle
- Drive Linkages
- Excavator Mounts/Hitch
- Diggalign - Pile/Auger Alignment system
- Torque Monitoring - Pressure Differential Gauge
- Torque Logic - Pile Alignment / Data Logging system

3/10/2026  
 Kenneth F. Wheeler, P.E.  
 PE #60417  
 Cool and Cobb Engineering Co.  
 203 W. Main St.  
 Avon Park, FL 33825

# PLANETARY ANCHOR DRIVES

## 9,000 FT LBS - 12,000 FT LBS



### OUTPUT SPEED & TORQUE

9ADS - STANDARD PRESSURE - 3500 PSI				12ADS - STANDARD PRESSURE - 3500 PSI			
OUTPUT SPEED		OUTPUT TORQUE		OUTPUT SPEED		OUTPUT TORQUE	
GPM	RPM	PSI	FT-LBS	GPM	RPM	PSI	FT-LBS
8	9	1,500	3,905	8	7	1,500	4,945
10	12	1,700	4,425	10	9	1,700	5,605
12	14	1,900	4,945	12	11	1,900	6,265
14	16	2,100	5,465	14	13	2,100	6,925
16	19	2,300	5,990	16	15	2,300	7,585
18	21	2,500	6,510	18	17	2,500	8,245
20	24	2,700	7,030	20	19	2,700	8,905
24	26	2,900	7,550	24	20	2,900	9,565
26	28	3,200	8,070	26	22	3,200	10,225
28	31	3,300	8,590	28	24	3,300	10,880
30	33	3,500	9,100	30	26	3,500	11,500
32	38			32	30		
34	40			34	32		
36	42			36	33		
38	45			38	35		
40	47			40	37		
42	49			42	39		
44	52			44	41		
46	54			46	43		

9ALS - LOW PRESSURE - 3000 PSI				12ALS - LOW PRESSURE - 3000 PSI			
OUTPUT SPEED		OUTPUT TORQUE		OUTPUT SPEED		OUTPUT TORQUE	
GPM	RPM	PSI	FT-LBS	GPM	RPM	PSI	FT-LBS
8	7	1 000	3 298	8	6	1 000	4 148
12	11	1 200	3 957	12	9	1 200	4 978
16	15	1 400	4 617	16	12	1 400	5 808
20	19	1 600	5 276	20	15	1 600	6 637
24	22	1 800	5 936	24	18	1 800	7 467
28	26	2 000	6 596	28	21	2 000	8 296
32	30	2 200	7 255	32	24	2 200	9 126
36	33	2 400	7 915	36	27	2 400	9 956
40	37	2 600	8 574	40	30	2 600	10 785
44	41	2 800	9 234	44	33	2 800	11 615
48	42	3 000	9 893	48	35	3 000	12 445

3/10/2026  
 Kenneth F. Wheeler, P.E.  
 PE #60417  
 Cool and Cobb Engineering Co.  
 203 W. Main St.  
 Avon Park, FL 33825

Output speed and torque specifications are THEORETICAL. Speed and torque output are dependent on the overall system efficiencies associated with the prime movers hydraulic system. This document should be used for information and comparative purposes only. When determining criteria, & application specific information is required, please contact DIGGA.

Do Not Scale

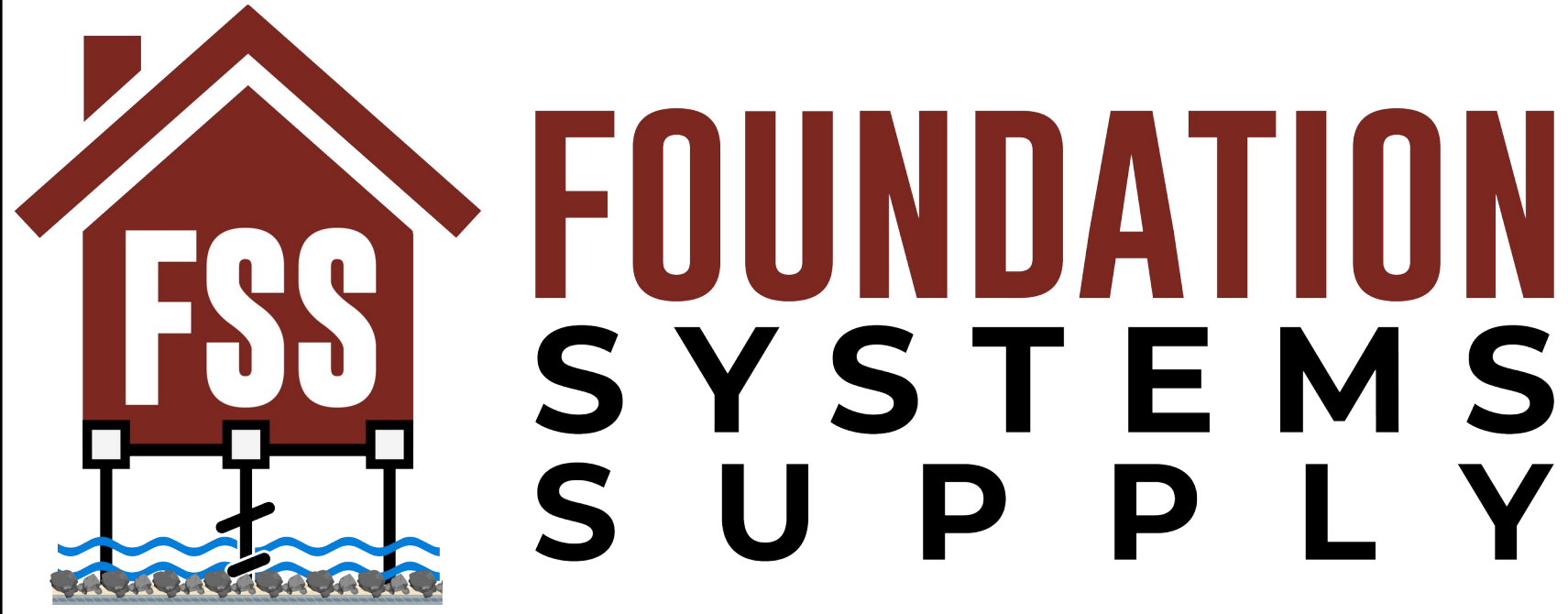

# Leads

Leads				
Part NO.	"A"	"B"	"C"	"D"
L5 NG 8	60"	8"		
L7 NG 10	84"	10"		
L5 NG 10 12	60"	8"	10"	
L7 NG 10 12	84"	10"	12"	
L7 NG 8 10 12	84"	8"	10"	12"

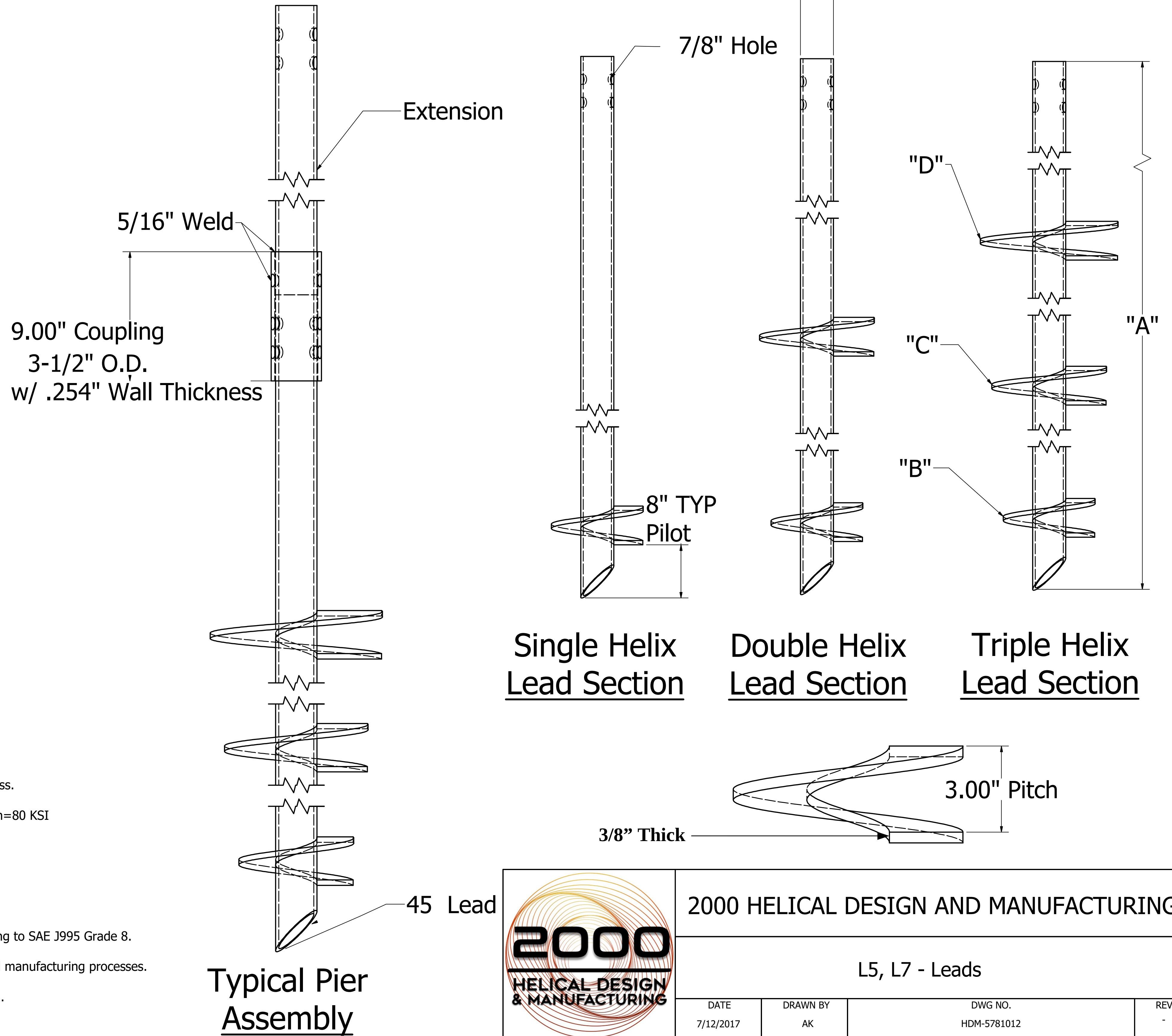

3/10/2026  
 Kenneth F. Wheeler, P.E.  
 PE #60417  
 Cool and Cobb Engineering Co.  
 203 W. Main St.  
 Avon Park, FL 33825

### -NOTES-

- Hot-dipped galvanized in accordance with ASTM A123.
- New Construction Bracket, Repair Bracket, Shaft Coupler, Lead Shafts, and Extensions have a nominal wall thickness.
- Helical pile lead Shafts and Extensions Are carbon steel piles that conform to API 5 CT L80. Minimum yield strength=80 KSI
- Shaft couplers are carbon steel pipes that conform to API 5 CT L80. Minimum yield strength= 80 KSI
- Helix plates are carbon steel plates conforming to ASTM A572, Grade 50. Minimum yield strength=68 KSI.
- Nominal spacing between helical plates is three times the diameter of the preceding helix plate.
- Coupling bolts: diameter X 4 long Hex Bolt conforming to SAE J429 Grade 8 with matching hex nuts conforming to SAE J995 Grade 8.
- 2000 Helical Design & Manufacturing has industry recognized written quality control for all incoming materials, and manufacturing processes.
- All welding to be done by welders certified under Section 4 of the AWS D1.1/D1, 1M Structural Welding Code-Steel.

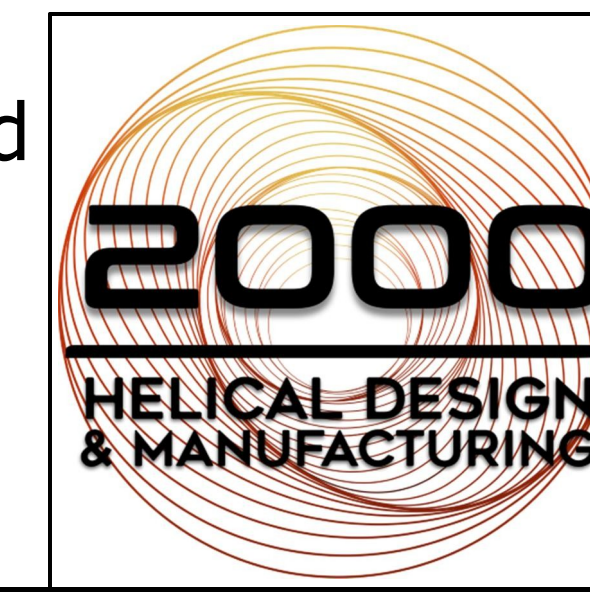

2000 HELICAL DESIGN AND MANUFACTURING			
L5, L7 - Leads			
DATE 7/12/2017	DRAWN BY AK	DWG NO. HDM-5781012	REV -

Do Not Scale

Torque Strength Rating - 9,281 Ft-Lbs  
 Ultimate Capacity (Tension/Compression) - 83.53 Kip  
 \* Based On A Torque Factor (Kt)=9

# Extensions

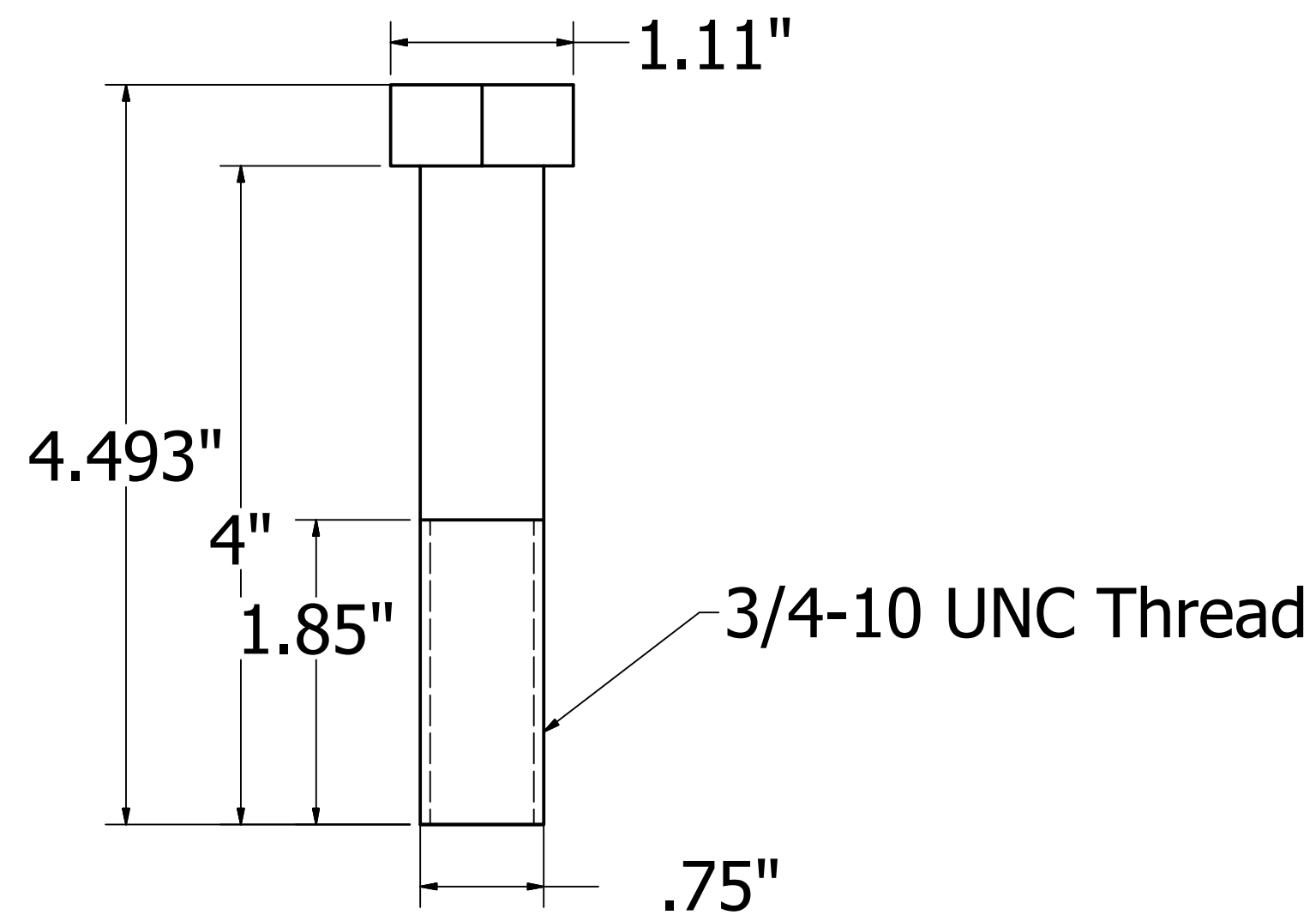

**Extension  
3/4x4 Bolt**

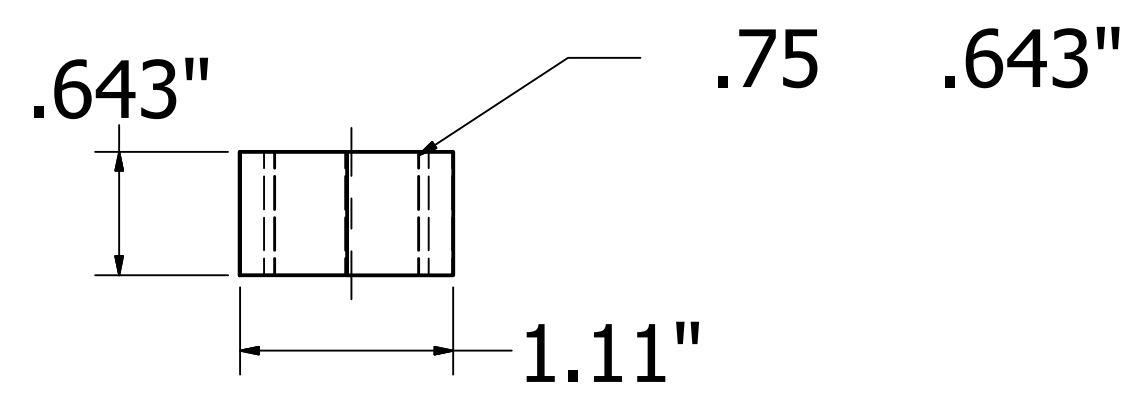

**Extension  
3/4 Nut**

**-NOTES-**

- Hot-dipped galvanized in accordance with ASTM A123.
- New Construction Bracket, Repair Bracket, Shaft Coupler, Lead Shafts, and Extensions have a nominal wall thickness.
- Helical pile lead Shafts and Extensions Are carbon steel piles that conform to API 5 CT L80. Minimum yield strength=80 KSI
- Shaft couplers are carbon steel pipes that conform to API 5 CT L80. Minimum yield strength= 80 KSI
- Helix plates are carbon steel plates conforming to ASTM A572, Grade 50. Minimum yield strength=68 KSI.
- Nominal spacing between helical plates is three times the diameter of the preceding helix plate.
- Coupling bolts: diameter X 4 long Hex Bolt conforming to SAE J429 Grade 8 with matching hex nuts conforming to SAE J995 Grade 8.
- 2000 Helical Design & Manufacturing has industry recognized written quality control for all incoming materials, and manufacturing processes.
- All welding to be done by welders certified under Section 4 of the AWS D1.1/D1, 1M Structural Welding Code-Steel.

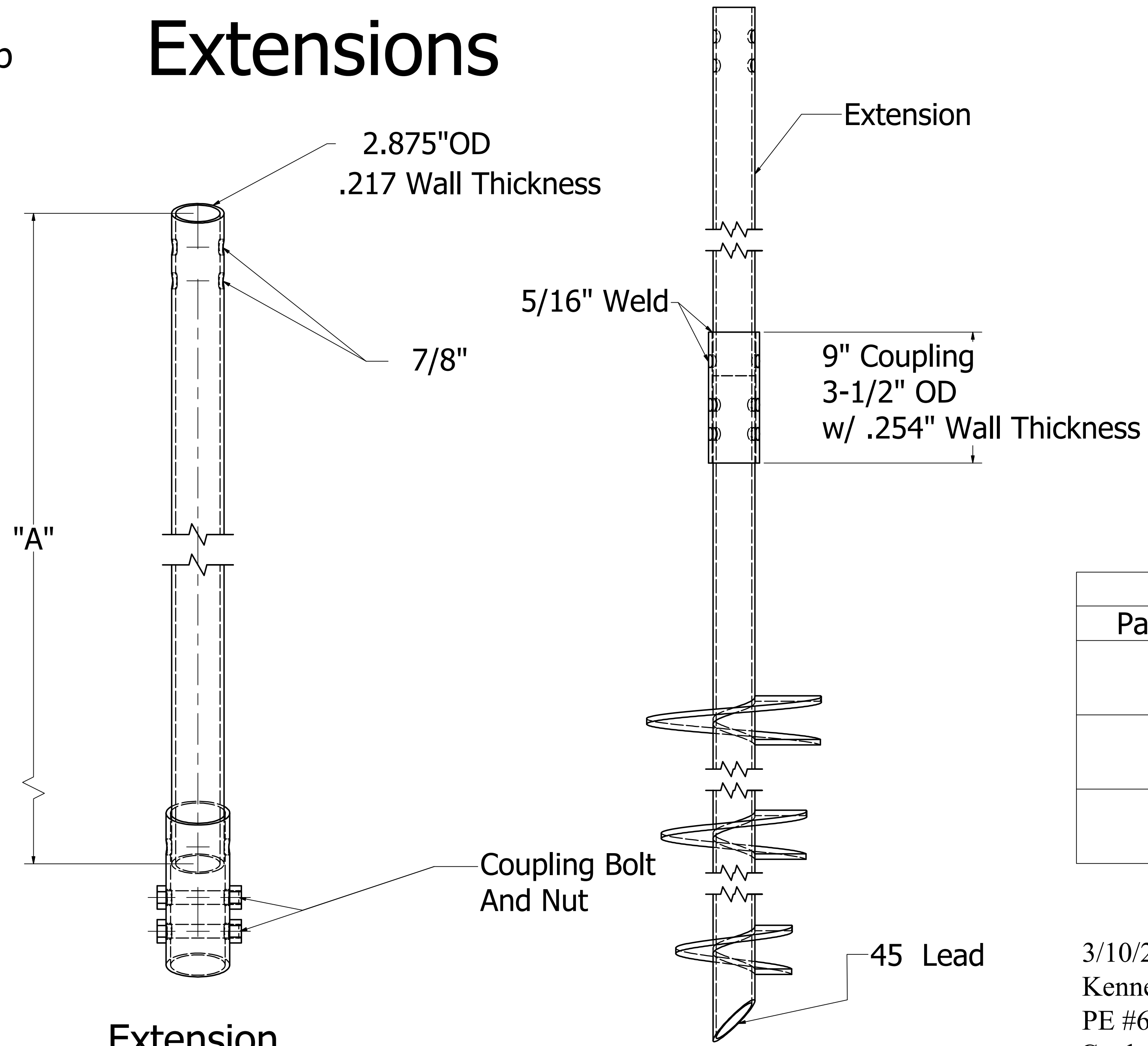

**Extension**

**Typical Pier  
Assembly**

Extension	
Part NO.	"A"
E3	36"
E5	60"
E7	84"

3/10/2026  
 Kenneth F. Wheeler, P.E.  
 PE #60417  
 Cool and Cobb Engineering Co.  
 203 W. Main St.  
 Avon Park, FL 33825



**FOUNDATION  
SYSTEMS  
SUPPLY**

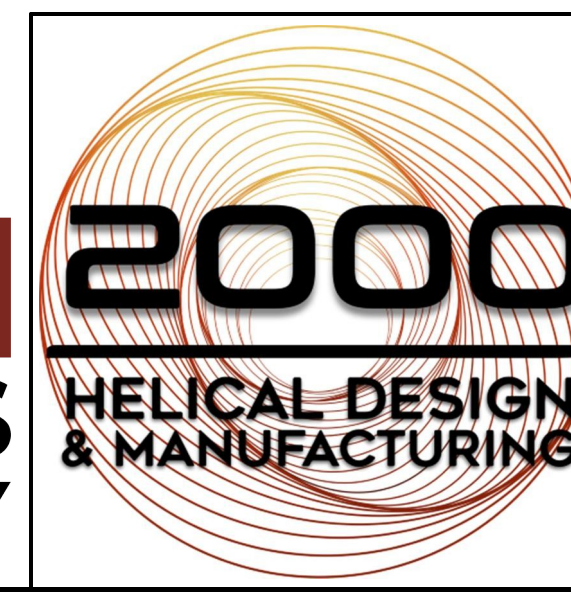

2000 HELICAL DESIGN AND MANUFACTURING			
E3, E5, E7 - Extensions			
DATE 7/20/2017	DRAWN BY AK	DWG NO. HDM-E357	REV -

3/10/2026

Kenneth F. Wheeler, P.E.

PE #60417

Cool and Cobb Engineering Co.

203 W. Main St.

Avon Park, FL 33825

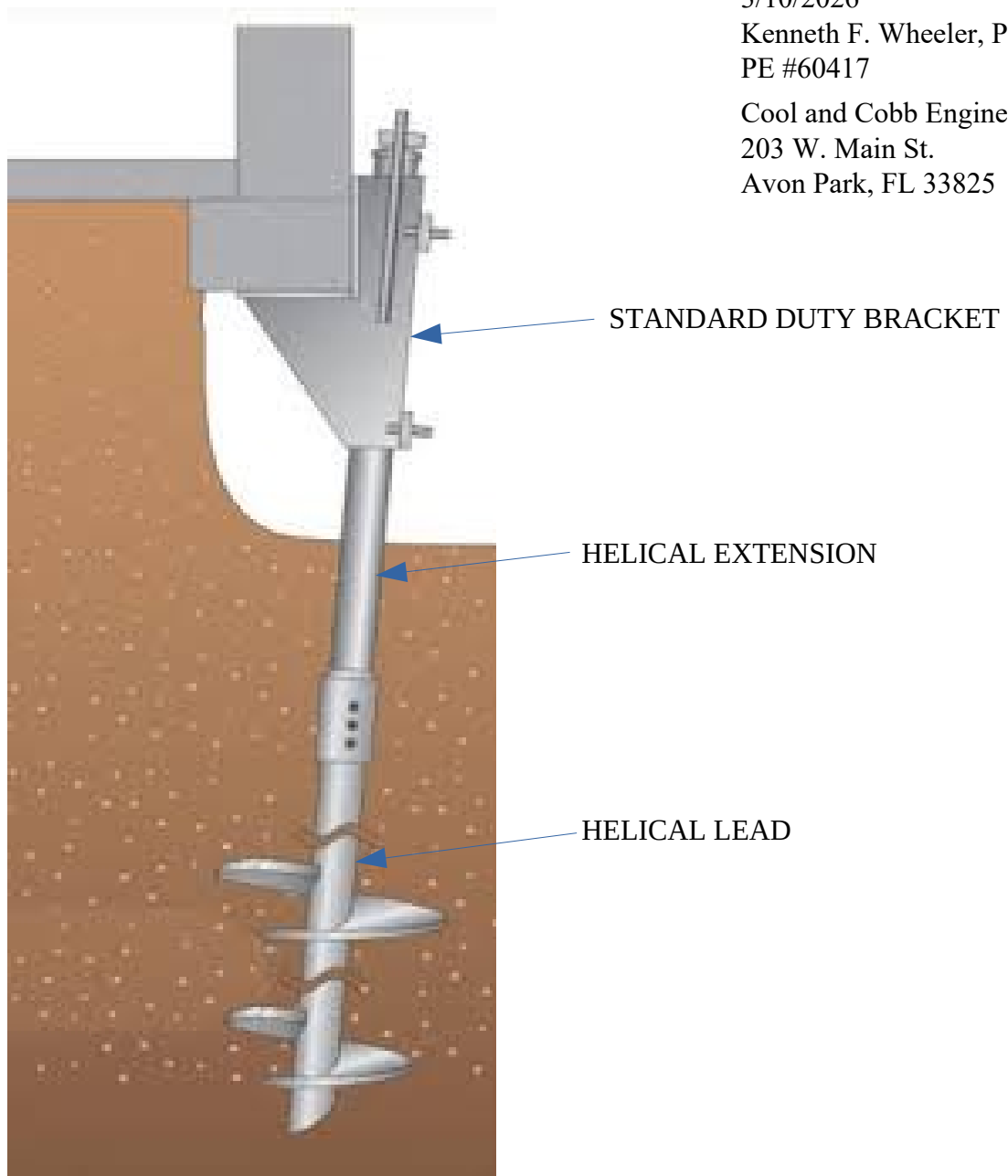

**STANDARD DUTY BRACKET (35 KIPS)**

**HELICAL LEAD – 7' with 10"/12" Flights, 2 7/8" OD, .217 Wall**  
(MAXIMUM TORQUE NOT TO EXCEED 10,000 FT LBS. ULTIMATE CAPACITY IS 72 KIPS)

**HELICAL EXTENSION – 7', 2 7/8" OD, .217 Wall**



1418 E. Busch Blvd., Suite 311  
Tampa FL 33612  
813-930-2846

## TerraThane 24-003 Geotechnical Foam System

NCFI Polyurethanes system 24-003 is a hydrophobic/hydro-insensitive, plural component, polymeric MDI-based polymer system designed for concrete lifting/leveling, joint matching, void filling and concrete under-sealing in wet environments. This system has been specially formulated for exceptional flow or spread under concrete road or slab section(s) when water is present. In certain applications this system can be used for deep soil injection applications when soil conditions dictate.

### Typical Properties of Components

Component	B-24-003	A2-000
Appearance	Transparent liquid	Transparent liquid
Brookfield Viscosity @ 30 rpm	500 cps at 72°F	200 cps at 72°F
Specific Gravity	1.07	1.24
Storage Temperature	50°F – 100°F	50°F – 110°F

### Mix Ratio

By weight.....100 parts poly : 116 parts iso  
By volume.....100 parts poly : 100 parts iso

### Typical Properties of Hand-Mixed System at 72°F and thru HPIM equipment

	at 72°F	at 110°F thru equipment
Cream Time	22 seconds	9 seconds
Tack Free Time	60 seconds	23 seconds
Rise Time	90 seconds	25 seconds
Free Rise Core Density	4 pcf	4 pcf

### Process Parameters

Iso Temperature	100°F to 120°F
Poly Temperature	100°F to 120°F
Mixing Pressure	Minimum 800 static, 600 dynamic psi, 1000/800 preferred



The Information contained herein is believed to be reliable, but no representations, guarantees or warranties of any kind are made as to its accuracy, suitability for particular applications or the results to be obtained there from. The information is based on laboratory work with small-scale equipment and does not necessarily indicate end product performance. Because of the variation in methods, conditions and equipment used commercially in processing these materials, no warranties or guarantees are made as to the suitability of the products for the application disclosed. Full-scale testing and end product performance are the sole responsibility of the user. NCFI Polyurethanes shall not be liable for and the customer assumes all risk and liability of any use or handling of any material beyond NCFI's direct control. NCFI MAKES NO WARRANTIES, EXPRESSED OR IMPLIED, BUT NOT LIMITED TO, THE IMPLIED WARRANTIES OR MERCHANTABILITY AND FITNESS FOR A PARTICULAR PURPOSE. Nothing contained herein is to be considered as permission, recommendations, nor as an inducement to practice any patented invention without permission of the patent owner.

3/10/2026  
Kenneth F. Wheeler, P.E.# 60417  
Cool and Cobb Engineering Co.  
203 W. Main St.,  
Avon Park, FL 33825

## Typical Foam Physical Properties

In-Place Density (ASTM D-1622)	5 - 6 pcf
Compressive Strength (ASTM D-1621), parallel to rise	80 - 100 psi
Compressive Modulus (ASTM D-1621), parallel to rise	2400 - 3200 psi
Tensile Strength (ASTM D-1623), parallel to rise	100 – 120 psi
Flexural Strength (ASTM D790)	387 psi
Flexural Modulus (ASTM D790)	13502 psi
Shear Strength (ASTM C273)	90 psi
Shear Modulus (ASTM C273)	677 psi
Closed cell content	> 92%
Water Absorption (ASTM D-2842)	≤ 0.04 lbs/ft <sup>2</sup>
NYDOT Hydro-Insensitivity test, GTP-9	> 96% density retention
	>93% comp str retention
<b>Dimensional stability, % volume change (ASTM D-2126)</b>	
	<b>Heat age at 158°F      Freezer at -20°F      Humid age at 100%RH &amp; 120°F</b>
<b>28 day aging</b>	-1.5%                      -0.1%                      -1.0%
<b>Resistance to Solvents</b>	Excellent
<b>Resistance to Mold and Mildew</b>	Excellent
<b>Maximum service temperature</b>	200°F

## Storage and Handling

Store the poly from 50°F to 100°F. Avoid moisture contamination during storage, handling, and processing. For both components, pad containers and day tanks with either nitrogen or dry air (desiccant cartridge or air dryer @ -40°F dew point). For optimum shelf life, the recommended storage temperature for iso is 50°F to 110°F. Do not expose iso to lower temperatures – freezing may occur. Shelf life is 6 months for factory sealed containers. To insure handling safety, consult the Safety Data Sheets associated with this product.

## Application Cautions

Careful consideration should be given to selection and application of any NCFI Polyurethane foam system, including injection under concrete slabs and/or into void areas (cavities), where excessive foam mass build-up can occur. Excessive polyurethane foam lift thickness will result in high internal temperatures within the injected foam. These high temperatures can result in degraded foam properties, or in extreme cases, spontaneous combustion. Single lift thickness should be limited to a maximum of 6 inches, allowing at least 15 minutes before an additional lift. Please consult NCFI Polyurethanes for safety considerations, polyurethane system selection and application recommendations.

Polyurethane products manufactured or produced from this liquid system may present a serious fire hazard if improperly used or allowed to remain exposed or unprotected. The character and magnitude of any such hazard will depend on a broad range of factors which are controlled and influenced by the manufacturing and production process, by the mode of application or installation and by the function and usage of the particular product. ***Any flammability rating contained in this literature is not intended to reflect hazards presented by this or any other material under actual fire conditions. These ratings are used solely to measure and describe the product's response to heat and flame under controlled laboratory conditions.*** Each person, firm or corporation engaged in the manufacture, production, application, installation or use of any polyurethane product should carefully determine whether there is a potential fire hazard associated with such product in a specific usage, and utilize all appropriate precautionary and safety measures.

The information on our data sheets is to assist customers in determining whether our products are suitable for their applications. The customers must satisfy themselves as to the suitability for specific cases. NCFI Polyurethanes warrants only that the material shall meet its specifications; this warranty is in lieu of all other written or unwritten, expressed or implied warranties and NCFI Polyurethanes expressly disclaims any warranty of merchantability, fitness for a particular purpose, or freedom from patent infringement. Accordingly, buyer assumes all risks whatsoever as to the use of the material. Buyer's exclusive remedy as to any breach of warranty, negligence or other claim shall be limited to the purchase price of the material. Failure to adhere strictly to any recommended procedures shall relieve NCFI Polyurethanes of all liability with respect to the material or the use thereof.