

Columbia County Building Permit Application

Revised 9-23-04

For Office Use Only Application # 0606-101 Date Received 6-28-06 By LH Permit # 1154/24754
Application Approved by - Zoning Official BLK Date 14-07-06 Plans Examiner OKTH Date 7-14-06
Flood Zone X Flood Development Permit N/A Zoning RSF-2 Land Use Plan Map Category RES. Low Dev.
Comments Attached Eng. letter for 1st Floor letter Elevation Letter Required to meet City Water this Requirement

Applicants Name JONATHAN PERRY CONSTRUCTION LLC Phone 386-719-7192

Address 373 NW OLD MILL DRIVE, LAKE CITY, FL 32055

Owners Name DONALD E. WILLIAMS, 541 SW AIRPARK GLEN, LAKE CITY, FL Phone 386-755-0764

911 Address 117 SW AMESBURY CT., L.C. #1 32024 - * Maxwell 10.8.08 - 239 Lane (of 6) - 911 - SENT FAX L.C. #1320

Contractors Name JONATHAN PERRY CONSTRUCTION LLC Phone 386-719-7192

Address 373 NW OLD MILL DRIVE, LAKE CITY, FL 32055

Fee Simple Owner Name & Address DONALD E. WILLIAMS, 541 SW AIRPARK GLEN, LAKE CITY, FL

Bonding Co. Name & Address NA

Architect/Engineer Name & Address TIM DELBENE & MARK DISSOSWAY

Mortgage Lenders Name & Address NA

Circle the correct power company - FL Power & Light - Clay Elect. - Suwannee Valley Elect. - Progressive Energy

Property ID Number 03099220 (23-45-16) Estimated Cost of Construction 130,000

Subdivision Name STONEHENGE Lot 20 Block Unit Phase 2

Driving Directions COUNTY ROAD 341 SOUTH APPROX. 5 MILES, THEN RIGHT ON STONEHENGE LANE AND PROCEED GUINEVERE TR. TO STOP SIGN TO LANCELOT, 1 R AND 16 S TR. SW 107 ON R.

Type of Construction FRAME - SFO Number of Existing Dwellings on Property 0

Total Acreage .5 Lot Size .5 Do you need a Culvert Permit or Culvert Waiver or Have an existing Drive

Actual Distance of Structure from Property Lines - Front 33 Side Side Rear

Total Building Height 16' Number of Stories 1 Heated Floor Area 1955 SF Roof Pitch 6 1924

Application is hereby made to obtain a permit to do work and installations as indicated. I certify that no work or installation has commenced prior to the issuance of a permit and that all work be performed to meet the standards of all laws regulating construction in this jurisdiction.

OWNERS AFFIDAVIT: I hereby certify that all the foregoing information is accurate and all work will be done in compliance with all applicable laws and regulating construction and zoning.

WARNING TO OWNER: YOUR FAILURE TO RECORD A NOTICE OF COMMENCEMENT MAY RESULT IN YOU PAYING TWICE FOR IMPROVEMENTS TO YOUR PROPERTY. IF YOU INTEND TO OBTAIN FINANCING, CONSULT WITH YOUR LENDER OR ATTORNEY BEFORE RECORDING YOUR NOTICE OF COMMENCEMENT.

JONATHAN PERRY CONSTRUCTION LLC Owner Builder or Agent (including Contractor) Contractor Signature

STATE OF FLORIDA COUNTY OF COLUMBIA Contractors License Number CBC-058042 Competency Card Number NOTARY STAMP/SEAL

Sworn to (or affirmed) and subscribed before me this 28th day of June 2006

Personally known or Produced Identification Notary Signature

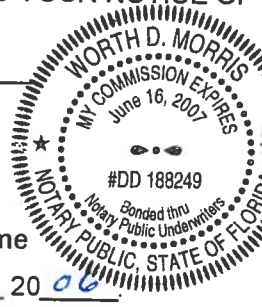

Signature of Notary Public, Worth D. Morris

- JW called Jonathan 7.14.06 - Cx# 1157

Columbia County Building Department Culvert Permit

Culvert Permit No. 000001154

DATE 07/17/2006 PARCEL ID # 23-4S-16-03099-220
APPLICANT JONATHAN PERRY PHONE 386.719.7192
ADDRESS 373 NW OLD MILL DRIVE LAKE CITY FL 32055
OWNER DONALD E. WILLIAMS PHONE 386.755.0764
ADDRESS 117 SW AMESBURY COURT LAKE CITY FL 32024
CONTRACTOR JONATHAN PERRY PHONE 386.719.7192
LOCATION OF PROPERTY C-341-S TO STONEHENGE NE, TR TO GUINEVERE, TR TO STOP SIGN TO LANCELOT,
TR AND IT'S THE 5TH LOT ON R.

SUBDIVISION/LOT/BLOCK/PHASE/UNIT STONEHENGE 20 2

SIGNATURE

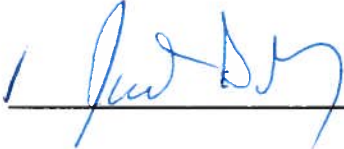

INSTALLATION REQUIREMENTS



Culvert size will be 18 inches in diameter with a total length of 32 feet, leaving 24 feet of driving surface. Both ends will be mitered 4 foot with a 4 : 1 slope and poured with a 4 inch thick reinforced concrete slab.

INSTALLATION NOTE: Turnouts will be required as follows:

- a) a majority of the current and existing driveway turnouts are paved, or;
- b) the driveway to be served will be paved or formed with concrete.

Turnouts shall be concrete or paved a minimum of 12 feet wide or the width of the concrete or paved driveway, whichever is greater. The width shall conform to the current and existing paved or concreted turnouts.



Culvert installation shall conform to the approved site plan standards.



Department of Transportation Permit installation approved standards.



Other _____

ALL PROPER SAFETY REQUIREMENTS SHOULD BE FOLLOWED
DURING THE INSTALATION OF THE CULVERT.

135 NE Hernando Ave., Suite B-21
Lake City, FL 32055
Phone: 386-758-1008 Fax: 386-758-2160

Amount Paid 25.00





STATE OF FLORIDA
DEPARTMENT OF HEALTH

APPLICATION FOR ONSITE SEWAGE DISPOSAL SYSTEM CONSTRUCTION PERMIT

Permit Application Number 06-0601N

PART II - SITE PLAN

Scale: Each block represents 5 feet and 1 inch = 50 feet.

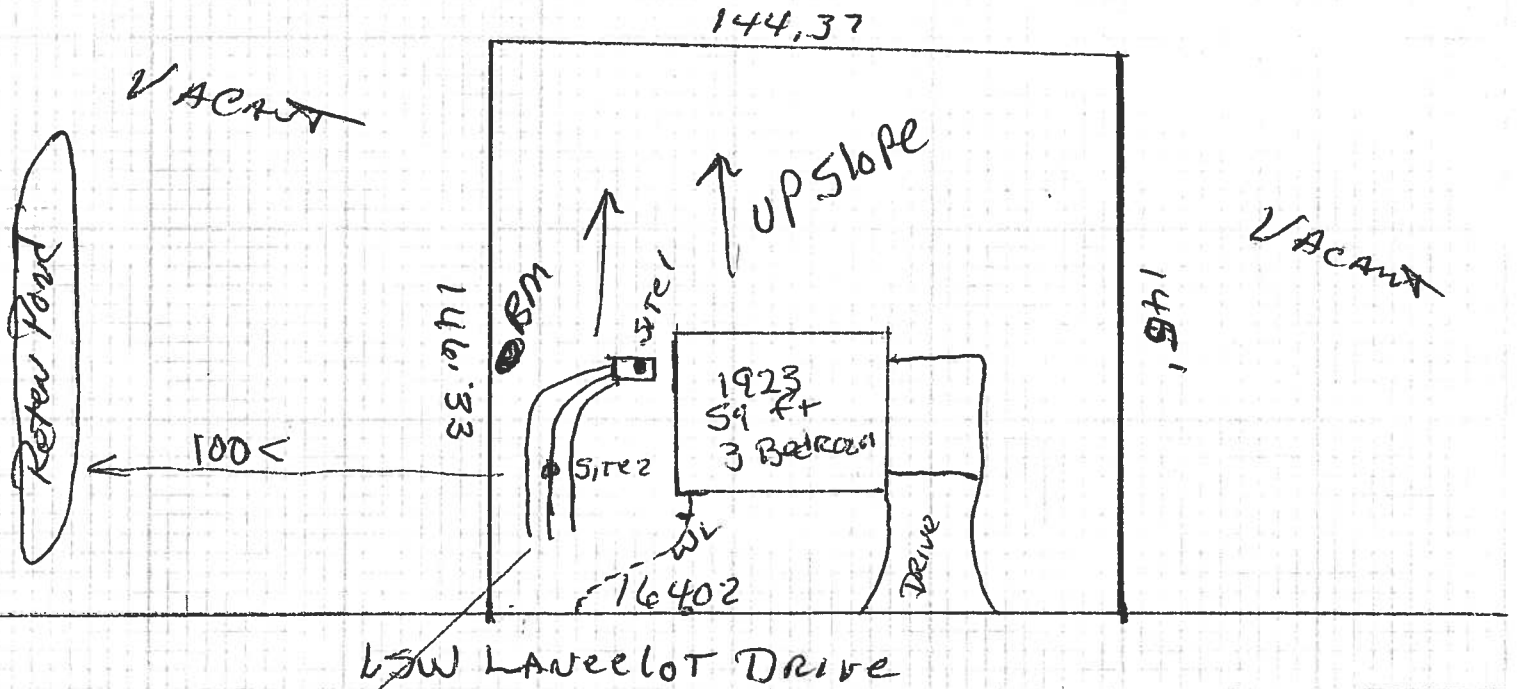
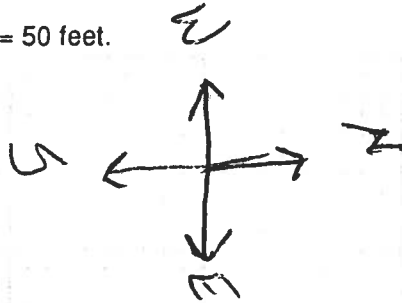

Notes:

UNIT II LOT 20
StoneHenge Donald Williams

Site Plan submitted by: Robert W Ford
Signature

Agent
Title

Plan Approved Not Approved

Date 6-26-06

By S Maddy ESII

Columbia CHD

County Health Department

ALL CHANGES MUST BE APPROVED BY THE COUNTY HEALTH DEPARTMENT

NOTICE OF COMMENCEMENT FORM
COLUMBIA COUNTY, FLORIDA

THE UNDERSIGNED hereby gives notice that improvement will be made to certain real property, and in accordance with Chapter 713, Florida Statutes, the following information is provided in this Notice of Commencement.

Tax Parcel ID Number 3099220

1. Description of property: (legal description of the property and street address or 911 address)

LOT 20 STONEHENGE SUBDIVISION PHASE 2, COLUMBIA COUNTY, FLORIDA

2. General description of improvement: NEW HOUSE

3. Owner Name & Address Donald E. Williams

541 SW Airpark Glen, LAKE CITY, FL 32025

Interest in Property OWNERS

4. Name & Address of Fee Simple Owner (if other than owner): SAME AS ABOVE

5. Contractor Name JONATHAN PERRY CONSTRUCTION LLC

Phone Number 719-7192

Address 373 NW OLD MILL DRIVE, LAKE CITY, FL 32055

6. Surety Holders Name NONE

Phone Number _____

Address _____

Amount of Bond _____

7. Lender Name NONE

Inst:2006015651 Date:06/28/2006 Time:14:45

A. J. DC, P. DeWitt Cason, Columbia County B:1088 P:913

Address _____

8. Persons within the State of Florida designated by the Owner upon whom notices or other documents may be served as provided by section 718.13 (1)(a) 7; Florida Statutes:

Name DONNY WILLIAMS CONSTRUCTION LLC

Phone Number 755-0764

Address 541 SW AIRPARK GLEN, LAKE CITY, FL

9. In addition to himself / herself the owner designates None of

_____ to receive a copy of the Lienor's Notice as provided in Section 713.13 (1) -

(a) 7. Phone Number of the designee NA

10. Expiration date of the Notice of Commencement (the expiration date is 1 (one) year from the date of recording,

(Unless a different date is specified) _____

NOTICE AS PER CHAPTER 713, Florida Statutes:

The owner must sign the notice of commencement and no one else may be permitted to sign in his/her stead.

Donald E. Williams
Signature of Owner



Sworn to (or affirmed) and subscribed before day of June 28th, 2006

NOTARY STAMP/SEAL

Worth D. Morris
Signature of Notary

COLUMBIA COUNTY 9-1-1 ADDRESSING / GIS DEPARTMENT

P. O. Box 1787, Lake City, FL 32056-1787
Telephone: (386) 758-1125 * Fax: (386) 758-1365 * E-mail: ron_croft@columbiacountyfla.com

ADDRESS ASSIGNMENT DATA

The Columbia County Board of County Commissioners has passed Ordinance 2001-9, which provides for a uniform numbering system. A copy of this ordinance is available in the Clerk of Court records, located in the courthouse. This new numbering system will increase the efficiency of POLICE, FIRE AND EMERGENCY MEDICAL vehicles responding to calls within Columbia County by immediately identifying the location of the caller.

Residential or other structure on Parcel Number:
23-4S-16-03099-220 (LOT 20 STONEHENGE PHASE 2)

Address Assignment:
234 SW LANCELOT GLN, LAKE CITY, FL, 32024

Any questions concerning this information should be referred to the 9-1-1 Addressing / GIS Department at the telephone number listed above.

24754

FLOOR ELEVATIONS

PROPERTY DESCRIPTION: **Stonehenge Subdivision, Phase 2**

OWNER: Donald E. Williams

PROJECT REQUIREMENTS: Finish floor elevations for Stonehenge Subdivision, Phase 2.

On all lots, except those listed below, the minimum finish floor elevation of all proposed habitable buildings shall be a minimum of 12 inches above the highest adjacent existing ground elevation at the proposed building.

Lots 1, 2, 3, 4, & 5: The minimum finish floor elevation of all proposed habitable buildings shall be the higher of 12 inches above the highest adjacent existing ground elevation at the proposed building or 12 inches above the highest adjacent roadway.

Lots 17, 18, 19, 20, & 21: The minimum finish floor elevation of all proposed habitable buildings shall be the higher of 12 inches above the highest adjacent existing ground elevation at the proposed building or 18 inches above the east end of pavement adjacent to the retention pond.

All lots and driveways shall be graded to direct all runoff around and away from all points on exterior of the proposed building without changing direction, final destination, or quantity of runoff leaving the site. Lots shall not be filled, except for building pads, next to retention ponds.

The above elevations were obtained by using highly variable factors determined by a study of the watershed and by accepted water management district rainfall data and practices. Many judgements and assumptions are required to establish these factors. The resultant data is sensitive to changes, particularly of antecedent conditions, fill, urbanization, channelization, and land use.

The elevations are based on the 100-year flood, which is the flood having a 1% chance of being exceeded in any year.

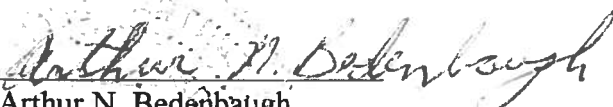
Arthur N. Bedenbaugh
Fla. P.E. # 9162
637 SW Hillcrest St.
Lake City, Florida 32025
(386) 752-5846

10-6-05

637 SW Hillcrest St * Lake City, Florida 32025
Phone (386) 752-5846

Compliance with Method B Chapter 6 of the Florida Energy Efficiency Code may be demonstrated by the use of Form 600B for single and multifamily residences of 3 stories or less in height, and additions to existing residential buildings. To comply, a building must meet or exceed all of the energy efficiency prescriptives in any one of the prescriptive component packages and comply with the prescriptive measures listed in Table 6B-1 of this form. An alternative method is provided for additions of 600 square feet or less by use of Form 600C. If a building does not comply with this method, it may still comply under other sections in Chapter 6 of the Code.

| | | | |
|---|-------------------------|---------------------------|---|
| PROJECT NAME: AND ADDRESS: | Lot 20 Stonehenge Ph II | BUILDER: | Jonathan D. Perry Const. |
| OWNER: | Donny Williams | PERMITTING OFFICE: | COLUMBIA |
| | | PERMIT NO.: | 28754 |
| | | CLIMATE ZONE: | 1 <input type="checkbox"/> 2 <input type="checkbox"/> 3 <input checked="" type="checkbox"/> |
| | | JURISDICTION NO.: | 821000 |

GENERAL DIRECTIONS

1. New construction including additions which incorporates any of the following features cannot comply using this method: steel stud walls, single assembly roof/ceiling construction, or skylights or other non-vertical roof glass.
2. Choose one of the component packages "A" through "E" from Table 6B-1 by which you intend to comply with the Code. Circle the column of the package you have chosen.
3. Fill in all the applicable spaces of the "To Be Installed" column on Table 6B-1 with the information requested. All "To Be Installed" values must be equal to or more efficient than the required levels.
4. Complete page 1 based on the "To Be Installed" column information.
5. Read "Minimum Requirements for All Packages", Table 6B-2 and check each box to indicate your intent to comply with all applicable items.
6. Read, sign and date the "Prepared By" certification statement at the bottom of page 1. The owner or owner's agent must also sign and date the form.

1. Compliance package chosen (A-E)
2. New construction or addition
3. Single family detached or Multifamily attached
4. If Multifamily—No. of units covered by this submission
5. Is this a worst case? (yes / no)
6. Conditioned floor area (sq. ft.)
7. Predominant eave overhang (ft.)
8. Glass type and area :
 - a. Clear glass
 - b. Tint, film or solar screen
9. Percentage of glass to floor area
10. Floor type, area or perimeter, and insulation:
 - a. Slab on grade (R-value)
 - b. Wood, raised (R-value)
 - c. Wood, common (R-value)
 - d. Concrete, raised (R-value)
 - e. Concrete, common (R-value)
11. Wall type, area and insulation:
 - a. Exterior: 1. Masonry (Insulation R-value)
2. Wood frame (Insulation R-value)
 - b. Adjacent: 1. Masonry (Insulation R-value)
2. Wood frame (Insulation R-value)
12. Ceiling type, area and insulation:
 - a. Under attic (Insulation R-value)
 - b. Single assembly (Insulation R-value)
13. Air Distribution System: Duct insulation, location
Test report (attach if required)
14. Cooling system
(Types: central, room unit, package terminal A.C., gas, none)
15. Heating system:
(Types: heat pump, elec. strip, nat. gas, L.P. gas, gas h.p., room or PTAC, none)
16. Hot water system:
(Types: elec., nat. gas, L.P. gas, solar, heat rec., ded. heat pump, other, none)

| | | Please Print | | CK |
|-------|-------------------|--------------|-------------|----------|
| 1. | A | | | |
| 2. | New | | | |
| 3. | SF | | | |
| 4. | N/A | | | |
| 5. | Yes | | | |
| 6. | 1924 | | | |
| 7. | 1'4" | | | |
| | | Single Pane | Double Pane | |
| 8a. | 202 | sq. ft. | | |
| 8b. | | sq. ft. | | |
| 9. | 10.5 | % | | |
| 10a. | R= 0 | | 254 | lin. ft. |
| 10b. | R= / | | | sq. ft. |
| 10c. | R= / | | | sq. ft. |
| 10d. | R= 0 | | 254 | sq. ft. |
| 10e. | R= / | | | sq. ft. |
| 11a-1 | R= | | | sq. ft. |
| 11a-2 | R= 13 | | 1923 | sq. ft. |
| 11b-1 | R= 13 | | 1923 | sq. ft. |
| 11b-2 | R= | | | sq. ft. |
| 12a. | R= 30 | | 1923 | sq. ft. |
| 12b. | R= | | | sq. ft. |
| 13. | R= | | | |
| 14a. | Type: Rudd | | | |
| 14b. | SEER/EER: 13 seer | | | |
| 14c. | Capacity: 3 ton | | | |
| 15a. | Type: Electric | | | |
| 15b. | HSPF/COP/AFUE: | | | |
| 15c. | Capacity: 3 Ton | | | |
| 16a. | Type: Rudd | | | |
| 16b. | EF: 192 | | | |

| | | |
|---|---------------|---|
| I hereby certify that the plans and specifications covered by the calculation are in compliance with the Florida Energy Code. | DATE: 6-26-06 | Review of plans and specifications covered by this calculation indicates compliance with the Florida Energy Code. Before construction is completed, this building will be inspected for compliance in accordance with Section 553.908, F.S. |
| PREPARED BY: [Signature] | DATE: 6-26-06 | BUILDING OFFICIAL: _____ |
| I hereby certify that this building, as designed, is in compliance with the Florida Energy Code. | | DATE: _____ |
| OWNER AGENT: [Signature] | | |

TABLE 6B-1

MINIMUM REQUIREMENTS

Climate Zones 1 2 3

| COMPONENTS | | PACKAGES FOR NEW CONSTRUCTION | | | | |
|----------------------|-----------------------------|--|-------------------------|-------------------|-------------------------|------------------------------|
| | | A | B | C | D | E |
| GLASS | Max.%of glass to Floor Area | 15% | 15% | 20% | 20% | 25% |
| | Type | Double Clear (DC) | Double Clear (DC) | Double Clear (DC) | Double Clear (DC) | Double Tint (DT) |
| | Overhang | 1'4" | 2' | 2' | 2' | 2' |
| WALLS | Masonry | EXTERIOR AND ADJACENT MASONRY WALLS R-5 COMMON MASONRY WALLS R-3 EACH SIDE. | | | | |
| | Wood Frame | EXTERIOR, ADJACENT, AND COMMON WOOD FRAME WALLS R-11 | | | | |
| CEILING | | R-30 | R-30 | R-30 | R-30 | R-30 |
| | | (NO SINGLE ASSEMBLY CEILING ALLOWED) | | | | |
| FLOORS | Slab-On-Grade | R-0 | | | | |
| | Raised Wood | R-19 (ONLY STEM WALL CONSTRUCTION ALLOWED EXCEPT PACKAGE C) | | | | |
| | Raised Concrete | R-7 | | | | |
| DUCTS | | R-6 | R-6 | R-6, TESTED | R-6 | R-6, TESTED |
| SPACE COOLING (SEER) | | 12.0 | 10.5 | 12.0 | 11.0 | 12.0 |
| HEAT | Elect. (HSPF) | 7.9 | 7.1 | 7.4 | 7.4 | 7.4 |
| | Gas/Oil (AFUE) | MINIMUM OF .73 (Direct heating) or .78 (Central) | | | | |
| HOT WATER SYSTEM | Electric Resistance** | EF .92 | NOT ALLOWED (SEE BELOW) | EF .92 | NOT ALLOWED (SEE BELOW) | EF .92 |
| | Gas & Oil** | MINIMUM EF OF .59 | | | | NATURAL GAS ONLY (SEE BELOW) |
| | Other | Any of the following are allowed: dedicated heat pump, heat recovery unit or solar system. | | | | |

| TO BE INSTALLED | |
|---|------------------------------|
| 10.5 % | |
| DC: <input checked="" type="checkbox"/> | DT: <input type="checkbox"/> |
| 1'4" FEET | |
| EXT: R = | |
| ADJ: R = | |
| COM: R = | |
| EXT: R = 11 | |
| ADJ: R = 11 | |
| COM: R = 11 | |
| UNDER ATTIC: R = 30 | |
| COMMON: R = | |
| R = | |
| R = | |
| R = R-7 | |
| R = 6 COND. <input checked="" type="checkbox"/> | |
| SEER = 12.00 | |
| COP = 7.9 | |
| AFUE = 8 | |
| EF = .92 | |
| EF = | |
| DHP: <input type="checkbox"/> | EF = |
| HRU: <input type="checkbox"/> | |
| SOLAR: <input type="checkbox"/> | EF = |

* Single package units minimum SEER=9.7, HSPF = 6.6.
 ** Minimum efficiencies for gas and electric hot water systems apply to 40 gallon water heaters. Refer to Table 612.1 ABC.3.2 for minimum Code efficiencies for oil water heaters and other sizes.

DESCRIPTION OF BUILDING COMPONENTS LISTED

Percent of Glass to Floor Area: This percentage is calculated by dividing the total of all glass areas by the total conditioned floor area.
Overhang: The overhang is the distance the roof or soffit projects out horizontally from the face of the glass. All glass areas shall be under an overhang of at least the prescribed length with the following exceptions:
 1) glass on the gabled ends of a house and 2) the glass in the lower stories of a multi-story house.
Wall, Ceiling and Floor Insulation Values: The R-values indicated represent the minimum acceptable insulation level added to the structural components of the wall, ceiling or floor. The R-value of the structural building materials shall not be included in this calculation. "Common" components are those separating conditioned tenancies in a multifamily building. "Adjacent" components separate conditioned space from unconditioned but enclosed space. "Exterior" components separate conditioned space from unconditioned and unenclosed space.
Floor: Slab-on-grade floors without edge insulation are acceptable. Raised wood floors shall have continuous stem walls with insulation placed on the stem wall or under the floor except Package C.
Ducts: "TESTED" shall mean the ducts have less than 5% leakage based on a certified test report by a State-approved tester.
Space Cooling System: Cooling systems shall have a Seasonal Energy Efficiency Ratio (SEER) for central units or Energy Efficiency Ratio (EER) for room units or PTAC's equal to or greater than the prescribed value.
Electric Space Heating Option: Heat pump systems shall be rated with a Heating Seasonal Performance Factor (HSPF) equal to or greater than the prescribed HSPF. Heat pump systems may contain electric strip backups meeting the criteria of section 608.1.ABC.3.2.1.2. No electric resistance space heat is allowed for these packages.
Electric Resistance Hot Water Option: For packages designated "Not Allowed", an electric resistance hot water system may be installed only in conjunction with one of the "Other Hot Water System Options". See below.
Other Hot Water System Options: Any dedicated heat pump, heat recovery unit, or solar hot water system may be installed. Solar systems must have an EF of 1.5 or higher. Electric resistance systems having an EF of .92 or greater, or natural gas systems with EF .59 or greater may be used in conjunction with these systems.

| TABLE 6B-2 | MINIMUM REQUIREMENTS FOR ALL PACKAGES | | CHECK |
|---|---------------------------------------|--|-------------------------------------|
| COMPONENTS | SECTION | REQUIREMENTS | |
| Exterior Joints & Cracks | 606.1 | To be caulked, gasketed, weather-stripped or otherwise sealed. | <input checked="" type="checkbox"/> |
| Exterior Windows & Doors | 606.1 | Max .3 cfm/sq.ft. window area; .5 cfm/sq.ft. door area. | <input checked="" type="checkbox"/> |
| Sole & Top Plates | 606.1 | Sole plates and penetrations through top plates of exterior walls must be sealed. | <input checked="" type="checkbox"/> |
| Recessed Lighting | 606.1 | Type IC rated with no penetrations (two alternatives allowed). | <input checked="" type="checkbox"/> |
| Multi-story Houses | 606.1 | Air barrier on perimeter of floor cavity between floors. | <input checked="" type="checkbox"/> |
| Exhaust Fans | 606.1 | Exhaust fans vented to unconditioned space shall have dampers, except for combustion devices with integral exhaust ductwork. | <input checked="" type="checkbox"/> |
| Water Heaters | 612.1 | Comply with efficiency requirements in Table 612.1. Switch or clearly marked circuit breaker (electric) or cutoff (gas) must be provided. External or built-in heat trap required for vertical pipe risers. | <input checked="" type="checkbox"/> |
| Swimming Pools & Spas | 612.1 | Spas & heated pools must have covers (except solar heated). Non-commercial pools must have a pump timer. Gas spa & pool heaters must have minimum thermal efficiency of 78%. | <input checked="" type="checkbox"/> |
| Hot Water Pipes | 612.1 | Insulation is required for hot water circulating systems (including heat recovery units). | <input checked="" type="checkbox"/> |
| Shower Heads | 612.1 | Water flow must be restricted to no more than 2.5 gallons per minute at 80 PSIG. | <input checked="" type="checkbox"/> |
| HVAC Duct Construction, Insulation & Installation | 610.1 | All ducts, fittings, mechanical equipment and plenum chambers shall be mechanically attached, sealed, insulated and installed in accordance with the criteria of Section 610.1. Ducts in attics must be insulated to a minimum of R-6. | <input checked="" type="checkbox"/> |
| HVAC Controls | 607.1 | Separate readily accessible manual or automatic thermostat for each system. | <input checked="" type="checkbox"/> |

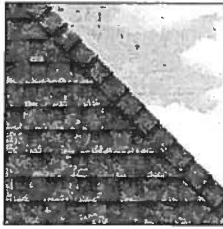

**PRESTIQUE®
HIGH DEFINITION®**

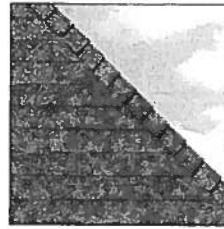

RAISED PROFILE®

**Prestique Plus *High Definition*
and Prestique Gallery Collection^{††}**

Product size _____ 13 $\frac{1}{2}$ " x 39 $\frac{1}{2}$ "
 Exposure _____ 5"
 Pieces/Bundle _____ 16
 Bundles/Square _____ 4/98.5 sq.ft.
 Squares/Pallet _____ 11

50-year limited warranty period:
 5-7**years non-prorated coverage for shingles and application labor with prorated coverage for remainder of limited warranty period, plus an option for transferability*. 5-year limited wind warranty*. Wind Coverage: standard 80 mph, extended 110 mph***

Raised Profile

Product size _____ 13 $\frac{1}{2}$ " x 38 $\frac{1}{2}$ "
 Exposure _____ 5"
 Pieces/Bundle _____ 22
 Bundles/Square _____ 3/100 sq.ft.
 Squares/Pallet _____ 16

30-year limited warranty period:
 5-7**years non-prorated coverage for shingles and application labor with prorated coverage for remainder of limited warranty period, plus an option for transferability*. 5-year limited wind warranty*. Wind Coverage: standard 70 mph.

Prestique I *High Definition*

Product size _____ 13 $\frac{1}{2}$ " x 39 $\frac{1}{2}$ "
 Exposure _____ 5"
 Pieces/Bundle _____ 16
 Bundles/Square _____ 4/98.5 sq.ft.
 Squares/Pallet _____ 14

40-year limited warranty period:
 5-7**years non-prorated coverage for shingles and application labor with prorated coverage for remainder of limited warranty period, plus an option for transferability*. 5-year limited wind warranty*. Wind Coverage: standard 80 mph, extended 90 mph***

HIP AND RIDGE SHINGLES

| | |
|--|---|
| Seal-A-Ridge[®] w/FLX[™] Size: 12" x 12" Exposure: 6 $\frac{1}{2}$ " Pieces/Bundle: 45 Coverage: 4 Bundles = 100 linear feet | Vented RidgeCrest[™] w/FLX[™] Size: 13" x 13 $\frac{1}{2}$ " Exposure: 9 $\frac{1}{2}$ " Pieces/Box: 26 Coverage: 5 boxes = 100 linear feet |
|--|---|

Prestique *High Definition*

Product size _____ 13 $\frac{1}{2}$ " x 38 $\frac{1}{2}$ "
 Exposure _____ 5"
 Pieces/Bundle _____ 22
 Bundles/Square _____ 3/100 sq.ft.
 Squares/Pallet _____ 16

30-year limited warranty period:
 5-7**years non-prorated coverage for shingles and application labor with prorated coverage for remainder of limited warranty period, plus an option for transferability*. 5-year limited wind warranty*. Wind Coverage: standard 80 mph.

Elk Starter Strip

52 Bundles/Pallet
 18 Pallets/Truck
 936 Bundles/Truck
 19 Pieces/Bundle
 1 Bundle = 120.33 linear feet

Available Colors (Check Availability): Antique Slate, Weatheredwood, Shakedown, Sablewood, Hickory, Barkwood, Forest Green, Wedgewood, Birchwood, Sandalwood, Gallery Collection: Balsam Forest[™], Weathered Sage[™], Sienna Sunset[™].

All Prestique, Raised Profile and Seal-A-Ridge, and Prestique Starter Strip roofing products contain sealant which activates with the sun's heat, bonding shingles into a wind and weather resistant cover that resists blow-offs and leaks.

Check for availability with built-in StainGuard[™] treatment to inhibit the discoloration of roofing granules caused by the growth of certain types of algae.

All Prestique and Raised Profile shingles meet UL[®] Wind Resistant (UL 997) and Class "A" Fire Ratings (UL 790); and ASTM Specifications D 3018, Type-I; D 3161, Type-I; E 108 and the requirements of ASTM D 3462.

All Prestique and Raised Profile shingles have approval from the Florida Building Code Commission, Metro-Dade County, ICBO, and Texas Department of Insurance.

*See actual limited warranty for conditions and limitations.

** Effective January 1, 2004, the seven year non-prorated Umbrella Coverage Period applies only when a full Elk Roof System is installed with the original installation of the Elk shingles, all in accordance with Elk's application instructions for such products. A full Elk roof system includes Elk Hip and Ridge shingles on all hips and ridges, Elk Starter Strip along all rake and eave edges, an Elk ventilation system, and Elk All-Climate Self-Adhering Underlayment in all valleys. Additionally, Elk All-Climate Self-Adhering Underlayment is required along the rake and eave edges of the roof in and north of the states of VA, KY, MD, KS, CO, UT, NV, & OR.

***For a limited Wind Warranty up to 110 mph for Prestique Gallery Collection, Prestique Plus, or 90 mph for Prestique I or GrandÉ, at least six (6) properly placed NAILS and Elk Starter Strip shingles are required. See application instructions printed on the shingle wrapper for additional requirements.

SPECIFICATIONS

Scope: Work includes furnishing all labor, materials and equipment necessary to complete installation of (name) shingles specified herein. Color shall be (name of color). Hip and ridge type to be Elk Seal-A-Ridge with formula FLX.

All exposed metal surfaces (flashing, vents, etc.) to be painted with matching Elk roof accessory paint.

PREPARATION OF ROOF DECK: Roof deck to be dry, well-seasoned 1" x 6" (25.4mm x 152.4mm) boards, exterior-grade plywood (exposure 1 rated sheathing) at least 3/8" (9.525mm) thick conforming to the specifications of the American Plywood Association; 7/16" (11.074mm) oriented strandboard; or chipboard. Most fire retardant plywood decks are NOT approved substrates for Elk shingles. Consult Elk Field Service for application specifications over other decks and other slopes.

Materials: Underlayment for standard roof slopes, 4" per foot (101.6/304.8mm) or greater: apply non-perforated No. 15 or 30 asphalt-saturated felt underlayment. For Low slopes[4" per foot (101.6/304.8mm) to a minimum of 2" per foot (50.8/304.8mm)], use two plies of underlayment overlapped a minimum of 1". Fasteners shall be of sufficient length and holding power for securing material as required by the application instructions printed on shingle wrapper.

For areas where algae is a problem, shingles shall be (name) with StainGuard treatment, as manufactured by the Elk Tuscaloosa plant. Hip and ridge type to be Seal-A-Ridge with formula FLX with StainGuard treatment.

Complete application instructions are published by Elk and printed on the back of every shingle bundle. All warranties are contingent upon the correct installation as shown on the instructions. These instructions are the minimum required to meet Elk application requirements. In some areas, building codes may require additional application techniques or methods beyond our instructions. In these cases, the local code must be followed. Under no circumstances will Elk accept application requirements less than those contained in its application instructions.

For specifications in CSI format, call 800.354.SPEC (7732) or e-mail specinfo@elkcorp.com

**SOUTHEAST &
ATLANTIC OFFICE:**
800.945.5551

CORPORATE HEADQUARTERS:
800.354.7732

PLANT LOCATION:
800.945.5545

ELK 
The Premium Choice[®]
www.elkcorp.com

5507 06/04

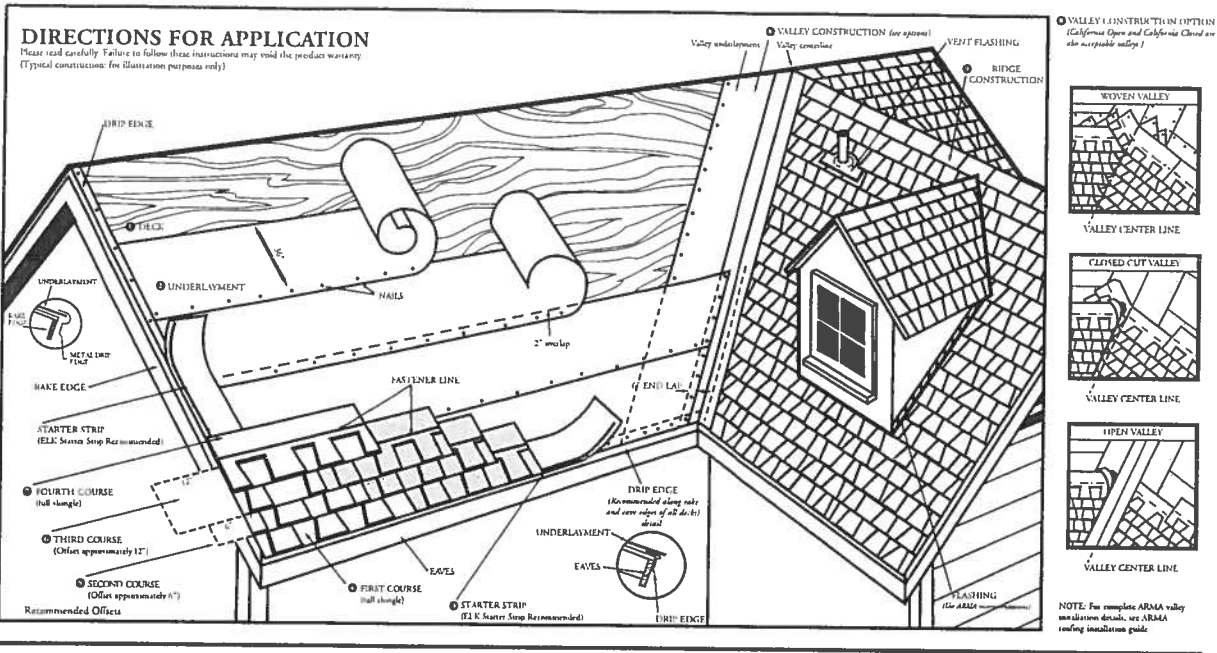

DIRECTIONS FOR APPLICATION

These application instructions are the minimum required to meet Elk's application requirements. Your failure to follow these instructions may void the product warranty. In some areas, the building codes may require additional application techniques or methods beyond our instructions. In these cases, the local code must be followed. Under no circumstances will Elk accept application requirements that are less than those printed here. Shingles should not be jammed tightly together. All attics should be properly ventilated. Note: It is not necessary to remove tape on back of shingle.

1 DECK PREPARATION

Roof decks should be dry, well-seasoned 1" x 6" boards or exterior grade plywood minimum 3/8" thick and conform to the specifications of the American Plywood Association or 7/16" oriented strandboard, or 7/16" chipboard.

2 UNDERLAYMENT

Apply underlayment (Non-Perforated No. 15 or 30 asphalt saturated felt). Elk Versashield® or self adhering underlayment is also acceptable.

For low slope (2/12 up to 4/12), completely cover the deck with two plies of underlayment overlapping a minimum of 19". Begin by fastening a 19" wide strip of underlayment placed along the eaves. Place a full 36" wide sheet over the starter, horizontally placed along the eaves and completely overlapping the starter strip.

EAVE FLASHING FOR ICE DAMS (ASK A ROOFING CONTRACTOR, REFER TO ARMA MANUAL OR CHECK LOCAL CODES)

For standard slope (4/12 to less than 21/12), use coated roll roofing of no less than 50 pounds over the felt underlayment extending from the eave edge to a point at least 24" beyond the inside wall of the living space below or one layer of a self-adhered eave and flashing membrane.

For low slope (2/12 up to 4/12), use a continuous layer of asphalt plastic cement between the two plies of underlayment from the eave edge up roof to a point at least 24" beyond the inside wall of the living space below or one layer of a self-adhered eave and flashing membrane.

Consult the Elk Technical Services Department for application specifications over other decks and other slopes.

3 STARTER SHINGLE COURSE

USE AN ELK STARTER STRIP OR THE HEADLAP OF A STRIP SHINGLE WITH THE ADHESIVE STRIP POSITIONED AT THE EAVE EDGE. With at least 3" trimmed from the end of the first shingle, start at the rake edge overhanging the eave and rake edges 1/2" to 3/4". Fasten 2" from the lower edge and 1" from each side.

4 FIRST COURSE

Start at rake and continue course with full shingles laid flush with the starter course. Shingles may be applied with a course alignment of 45° on the roof.

5 SECOND COURSE

Offset the second course of shingles with respect to the first by approximately 6". Other offsets are approved if greater than 4".

6 THIRD COURSE

Offset the next course by 6" with respect to the second course, or consistent with the original offset.

7 FOURTH COURSE

Start at the rake and continue with full shingles across roof.

FIFTH AND SUCCEEDING COURSES.

Repeat application as shown for second, third, and fourth courses. Do not rack shingles straight up the roof. Offsets may be adjusted around valleys and penetrations.

8 VALLEY CONSTRUCTION

Open, woven and closed cut valleys are acceptable when applied by Asphalt Roofing Manufacturing Association (ARMA) recommended procedures. For metal valleys, use 36" wide vertical underlayment prior to applying metal flashing (secure edge with nails). No nails are to be within 6" of valley center.

9 RIDGE CONSTRUCTION

For ridge construction Elk recommends Class "A" Z-Ridge or Seal-A-Ridge® with formula FLX™ or RidgeCrest™ with FLX (See ridge package for installation instructions). Vented RidgeCrest or 3-tab shingles are also approved.

FASTENERS

While nailing is the preferred method for Elk shingles, Elk will accept fastening methods according to the following instructions.

Using the fastener line as a reference, nail or staple the shingle in the double thickness common bond area. For shingles without a fastener line, nails or staples must be placed between and/or in the sealant dots.

NAILS: Corrosive resistant, 3/8" head, minimum 12-gauge roofing nails. Elk recommends 1-1/4" for new roofs and 1-1/2" for re-roofs. In cases where you are applying shingles to a roof that has an exposed overhang, for new roofs only, 3/4" shank nails are allowed to be used from the eave's edge to a point up the roof that is past the outside wall line. 1" shank nails allowed for re-roof.

STAPLES: Corrosive resistant, 16-gauge minimum, crown width minimum of 15/16". Note: An improperly adjusted staple gun can result in raised staples that can cause a fish-mouthed appearance and can prevent sealing.

Fasteners should be long enough to obtain 3/4" deck penetration or penetration through deck, whichever is less. This product meets the requirements of the IRC 2003 code when fastened with 4 nails.

MANSARD APPLICATIONS

Correct fastening is critical to the performance of the roof. For slopes exceeding 60° (or 21/12) use six fasteners per shingle. Locate fasteners in the fastener area 1" from each side edge with the remaining four fasteners equally spaced along the length of the double thickness (laminated) area. Only fastening methods according to the above instructions are acceptable.

LIMITED WIND WARRANTY

- For a Limited Wind Warranty, all Prestique and Raised Profile™ shingles must be applied with 4 properly placed fasteners, or in the case of mansard applications, 6 properly placed fasteners per shingle.
- For a Limited Wind Warranty up to 110 MPH for Prestique Gallery Collection or Prestique Plus or 90 MPH for Prestique I, shingles must be applied with 6 properly placed NAILS per shingle. SHINGLES APPLIED WITH STAPLES WILL NOT QUALIFY FOR THIS ENHANCED LIMITED WIND WARRANTY. Also, Elk Starter Strip shingles must be applied at the eaves and rake edges to qualify Prestique Plus, Prestique Gallery Collection and Prestique I shingles for this enhanced Limited Wind Warranty. Under no circumstances should the Elk Shingles or the Elk Starter Strip overhang the eaves or rake edge more than 3/4" of an inch.

HELP STOP BLOW-OFFS AND CALL-BACKS

A minimum of four fasteners must be driven into the DOUBLE THICKNESS (laminated) area of the shingle. Nails or staples must be placed along – and through – the 'fastener line' or on products without fastener lines, nail or staple between and in line with sealant dots. CAUTION: Do not use fastener line for shingle alignment.

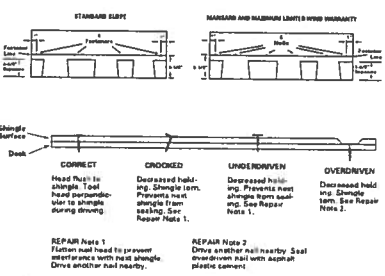

Refer to local codes which in some areas may require specific application techniques beyond those Elk has specified. All Prestique and Raised Profile shingles have a U.L.® Wind Resistance Rating when applied in accordance with these instructions using nails or staples on re-roofs as well as new construction.

CAUTION TO WHOLESALER: Careless and improper storage or handling can harm fiberglass shingles. Keep these shingles completely covered, dry, reasonably cool, and protected from the weather. Do not store near various sources of heat. Do not store in direct sunlight until applied. DO NOT DOUBLE STACK. Systematically rotate all stock so that the material that has been stored the longest will be the first to be moved out.



©2004, Elk Premium Building Products, Inc. All trademarks, ®, are registered trademarks of Elk Premium Building Products, Inc. All trademarks, ™, are trademarks pending registration of Elk Premium Building Products, Inc., an ElkCorp company. UL is registered trademark of Underwriters Laboratories, Inc.

** LAMAR BOOZER **
 900 EAST PUTNAM STREET
 LAKE CITY, FL 32055

PROJECT: CUSTOM
 CLIENT: J PERRY
 DATE: 9 19 05

RESIDENTIAL/LIGHT COMMERCIAL HVAC LOADS

DESIGNER: LAMAR BOOZER

CLIENT INFORMATION:

NAME: J PERRY
 ADDRESS:
 CITY, STATE: LAKE CITY, FLORIDA

TOTAL BUILDING LOADS:

| BLDG. LOAD DESCRIPTIONS | AREA QUAN | SEN. LOSS | LAT. + GAIN | SEN. = GAIN | TOTAL GAIN | |
|---------------------------------------|-----------|-----------|-------------|-------------|------------|--------|
| 3-C WINDOW DBL PANE CLR GLS METL FR | 140 | 4,568 | 0 | 7,721 | 7,721 | |
| 9-I FRENCH DOOR DBL CLR GLS METL FR | 40 | 1,357 | 0 | 1,536 | 1,536 | |
| 12-D WALL R-11 +1/2"ASPHLT BRD(R-1.3) | 1,252 | 4,507 | 0 | 2,462 | 2,462 | |
| 11-C DOOR METAL POLYSTYRENE CORE | 60 | 1,269 | 0 | 693 | 693 | |
| 16-G CEILING R-30 INSULATION | 1,934 | 2,466 | 0 | 2,466 | 2,466 | |
| 22-A SLAB ON GRADE NO EDGE INSUL | 44 | 1,604 | 0 | 0 | 0 | |
| 22-B SLAB ON GRADE 1" EDGE INS(R-5) | 142 | 2,620 | 0 | 0 | 0 | |
| SUBTOTALS FOR STRUCTURE: | | 3,612 | 18,391 | 0 | 14,878 | 14,878 |
| PEOPLE | 9 | 0 | 0 | 2,700 | 2,700 | |
| APPLIANCES | 0 | 0 | 1,800 | 1,500 | 3,300 | |
| DUCTWORK | 0 | 919 | 0 | 1,908 | 1,908 | |
| INFILTRATION W.CFM: 0.0 S.CFM: 0.0 | 0 | 0 | 0 | 0 | 0 | |
| VENTILATION W.CFM: 0.0 S.CFM: 0.0 | 0 | 0 | 0 | 0 | 0 | |
| SENSIBLE GAIN TOTAL | | | | 20,986 | | |
| TEMP. SWING MULTIPLIER | | | | X 1.00 | | |
| BUILDING LOAD TOTALS | | 19,310 | 1,800 | 20,986 | 22,786 | |

SUPPLY CFM AT 20 DEG DT: 954 CFM PER SQUARE FOOT: 0.574
 SQUARE FT. OF ROOM AREA: 1,934 SQUARE FOOT PER TON: 874.748

TOTAL HEATING REQUIRED WITH OUTSIDE AIR: 19.310 MBH
 TOTAL COOLING REQUIRED WITH OUTSIDE AIR: 2.899 TONS

CALCULATIONS ARE BASED ON 7TH EDITION OF ACCA MANUAL J.
 ALL COMPUTED RESULTS ARE ESTIMATES AS BUILDING USE AND WEATHER MAY VARY.
 BE SURE TO SELECT A UNIT THAT MEETS BOTH SENSIBLE AND LATENT LOADS.

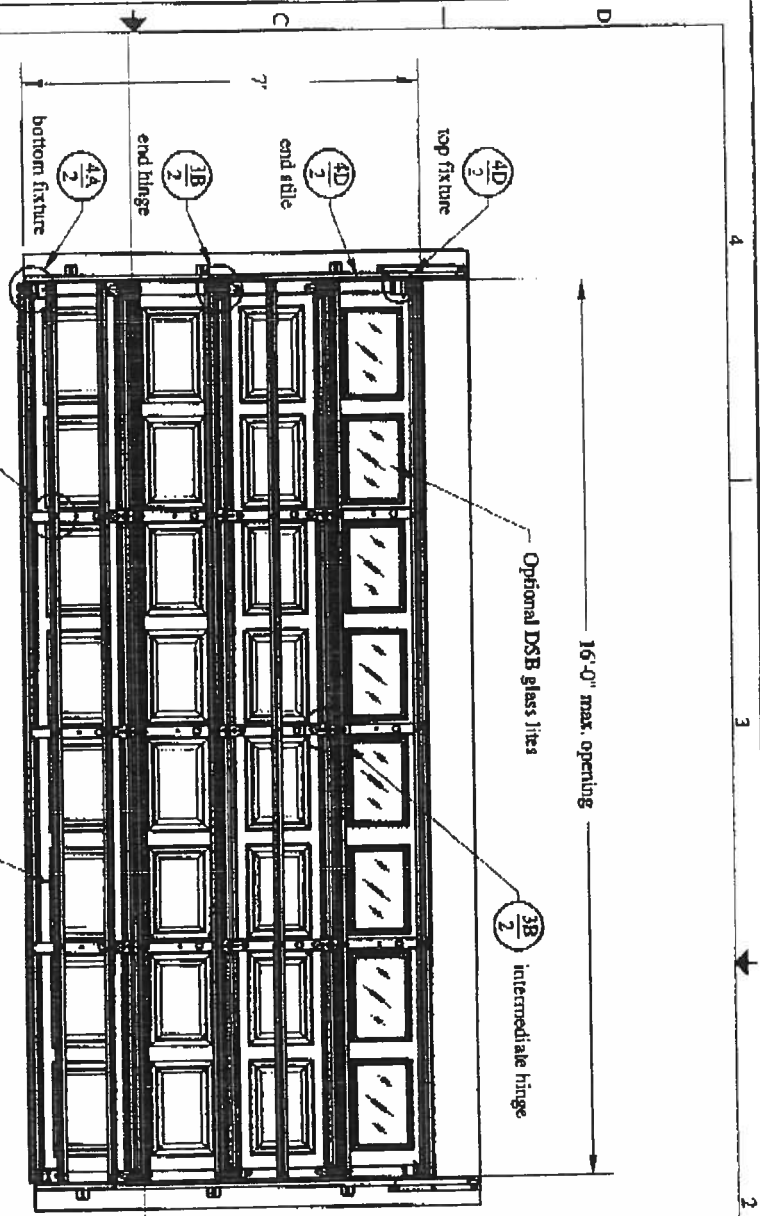

| Door Model | Gauge | Decimals |
|------------|-------|----------|
| 2250/2251 | 24 | .0185 |
| 4250/4251 | 25 | .0165 |
| 2240/2241 | 24 | .0225 |
| 4240/4241 | 24 | .0225 |
| 5240/5241 | 24 | .0225 |

| door height | section quantity | stud quantity | trk brkt per side |
|------------------|------------------|---------------|-------------------|
| 6'-6" to 7'-0" | 4 | 7 | 3 |
| 7'-6" to 8'-0" | 5 | 8 | 4 |
| 8'-3" to 8'-9" | 5 | 9 | 4 |
| 9'-0" to 10'-6" | 6 | 11 | 5 |
| 10'-9" to 12'-3" | 7 | 13 | 6 |
| 12'-6" to 14'-0" | 8 | 15 | 7 |

Refer to Supplemental Instructions for strut placement on doors over 7'-0" high

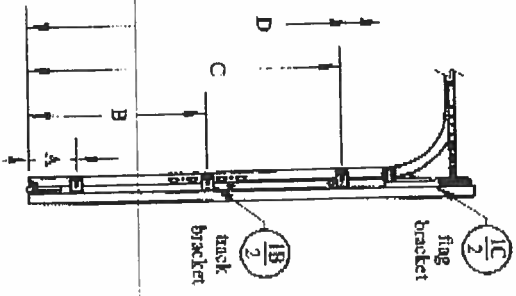

| Track Bracket Chart | door height | | | | | | | | | |
|---------------------|-------------|-------|-------|-------|-------|-------|-------|-------|-------|-------|
| | 6'-6" | 6'-9" | 7'-0" | 7'-6" | 7'-9" | 8'-0" | 8'-3" | 8'-6" | 8'-9" | 9'-0" |
| A | 10" | 7" | 10" | 10" | 10" | 7" | 10" | 4" | 7" | 10" |
| B | 35" | 35" | 38" | 38" | 38" | 34" | 32" | 35" | 35" | 36" |
| C | 69" | 61" | 66" | 58" | 55" | 58" | 60" | 63" | 66" | 66" |
| D | n/a | n/a | 72" | 72" | 69" | 81" | 84" | 87" | 87" | 87" |

Track bracket locations shown above are for doors up to five sections high. Additional door sections may be added for a maximum door height of 14'-0". One track bracket (per track) must be added for each section and spaced as a distance not greater than the corresponding section height.

This door has been tested in accordance with ANSIS/DASMA 108-2002
 Design Pressure (DP): 18.5 psf / 20.7 nsg
 Test Pressure (TP): 27.8 psf / 31.1 nsg
 Per 2004 FB/C Table 1609.6E, DP meets or exceeds basic wind speed of
 V = 110 MPH for Exposure B and mean roof height of 30' or less
 V = 93 MPH for Exposure C and mean roof height of 30' or less
 Maximum door size: 16'-0" wide by 14'-0" tall
 Glazing and door have not been tested for windborne debris.
 Wood back and supporting structural elements shall be designed by a
 registered professional engineer for wind loads shown on this drawing.
 If door is not electrically operated, a lock must be installed.

Professional Engineer's seal provided
 only for verification of windload
 construction details:

John E. Spake, P.E.
 1411 LeMay Street #205
 Carrollton, Texas 75007
 Florida P.E. # 51737

FL 5519

5110 10-25-2005
 Model 2250/51 (16'-0" wide)
 C.H.I. Drawing: Z3-1607-01100

Details on some views may have been omitted for clarity.

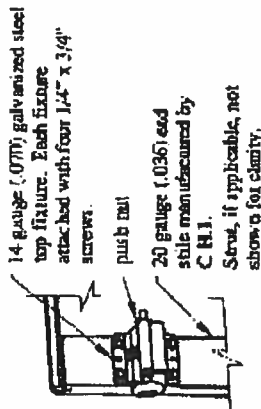

14-gauge (.077) galvanized steel top fixture. Each fixture attached with four 1/4" x 3/4" screws.

push nut

20-gauge (.036) end stile manufactured by C.H.I.

Screw, if applicable, not shown for clarity.

The 2x6 vertical wood jambs are to be grade 2 or better southern pine. Fasteners may be countersunk to provide a flush mounting surface.

2" x 7/16" (nominal) Stop molding required (not supplied by C.H.I.)

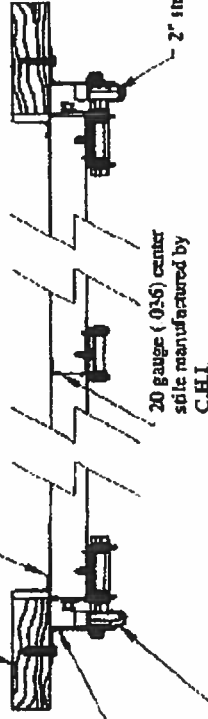

12-gauge (.095) galvanized steel track bracket fastened to wood jamb with one 5/16" x 1-5/8" wood lag screw per bracket.

2" x .051 min. galvanized steel track fastened to track brackets. Each track bracket attached with one 1/4" x 5/8" track bolt and nut.

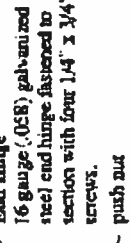

End Hinge
16-gauge (.028) galvanized steel end hinge fastened to 1/4" x 3/4" section with four 1/4" x 3/4" screws.

push nut

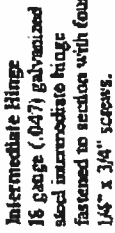

Intermediate Hinge
16-gauge (.047) galvanized steel intermediate hinge fastened to section with four 1/4" x 3/4" screws.

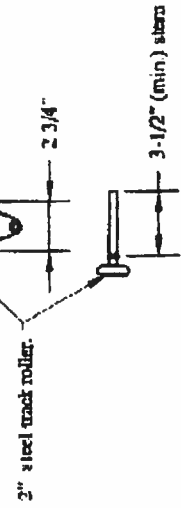

2" steel track roller.

3-1/2" (min) slots

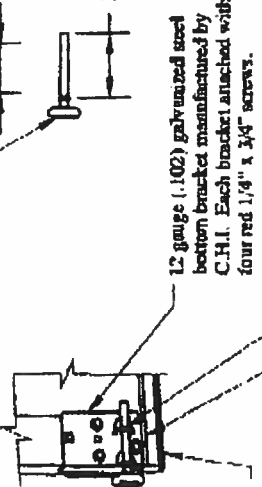

12-gauge (.102) galvanized steel bottom bracket manufactured by C.H.I. Each bracket attached with four red 1/8" x 3/4" screws.

push nut

Aluminum extrusion

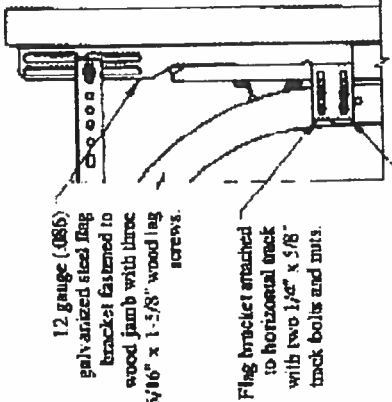

12-gauge (.086) galvanized steel flag bracket fastened to wood jamb with three 5/16" x 1-5/8" wood lag screws.

Flag bracket attached to horizontal track with two 1/4" x 5/8" track bolts and nuts.

Flag bracket attached to vertical track with two 1/4" x 5/8" track bolts and nuts.

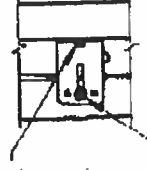

12-gauge (.095) galvanized steel track bracket fastened to wood jamb with one 5/16" x 1-5/8" wood lag screw per bracket.

Each track bracket attached with one 1/4" x 5/8" track bolt and nut. Or two 1/4" x 1 1/2" rivets.

Design Load: 18.5 pos / 20.7 neg
Test Load: 27.8 pos / 31.1 neg
page 2 of 2

John E. Scates, P.E.
1411 Lemay Street #205
Carrollton, Texas 75007
Florida P.E. # 51737

Professional Engineer's seal provided only for verification of windload construction details

C.H.I. Drawing: Z-3-1607-01100

GLASS INSERT IN DOOR OR SIDELITE PANEL

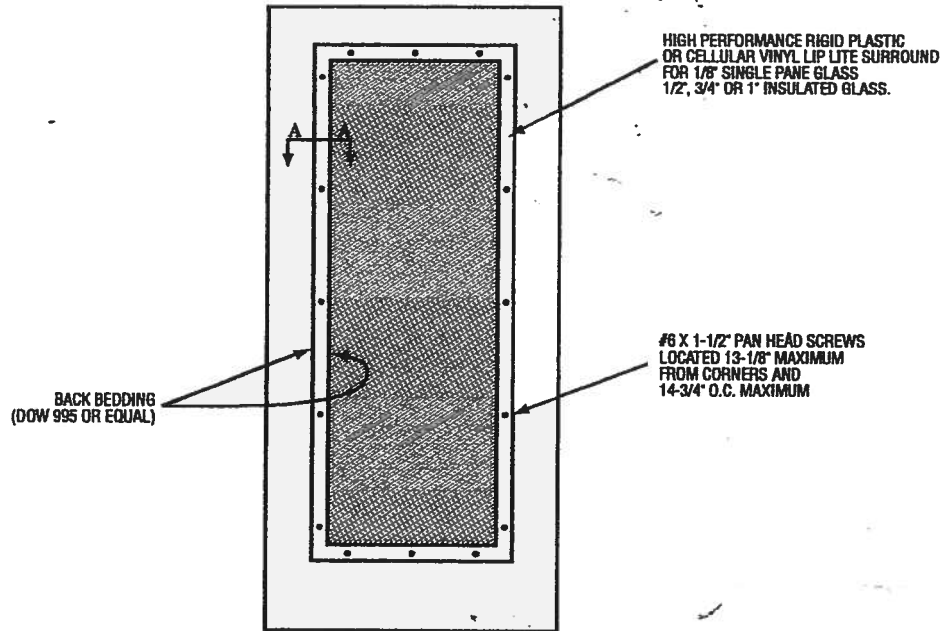

SECTION A-A TYPICAL RIGID PLASTIC LIP LITE SURROUND

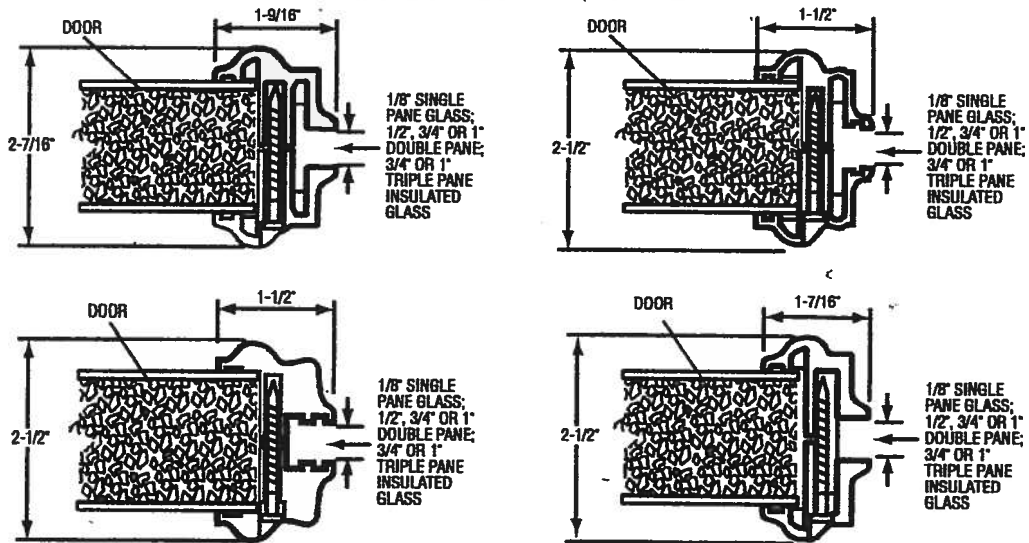

*Glass inserts to be sub-listed by Intertek Testing Services/ETL Semko or approved validation service.

Warrick Hersey Test Data Review Certificate #3026447A; #3026447B; #3026447C and GDP/Test Report Validation Matrix #3026447A-001, 002, 003; #3026447B-001, 002, 003; #3026447C-001, 002, 003 provides additional information - available from the ITS/WH website (www.etssemko.com), the Masonite website (www.masonite.com) or the Masonite technical center.

WOOD-EDGE STEEL DOORS

APPROVED ARRANGEMENT:

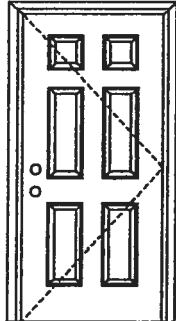

Test Data Review Certificate #3026447A and COP/Test Report Validation Matrix #3026447A-001 provides additional information - available from the ITS/WH website (www.etsenrko.com), the Masonite website (www.masonite.com) or the Masonite technical center.

Note:
Units of other sizes are covered by this report as long as the panel used does not exceed 3'0" x 6'8".

Single Door
Maximum unit size = 3'0" x 6'8"

Design Pressure
+66.0/-66.0
limited water unless special threshold design is used.

Large Missile Impact Resistance
Hurricane protective system (shutters) is NOT REQUIRED.

Actual design pressure and impact resistant requirements for a specific building design and geographic location is determined by ASCE 7-national, state or local building codes specify the edition required.

MINIMUM ASSEMBLY DETAIL:

Compliance requires that minimum assembly details have been followed – see MAD-WL-MA0001-02.

MINIMUM INSTALLATION DETAIL:

Compliance requires that minimum installation details have been followed – see MID-WL-MA0001-02.

APPROVED DOOR STYLES:



Rush



Arch Top 3-panel



3-panel



6-panel



New England 4-panel



Eyebrow 4-panel



8-panel



9-panel



15-panel



5-panel



5-panel with scroll



Eyebrow 5-panel



Eyebrow 5-panel with scroll

SINGLE DOOR

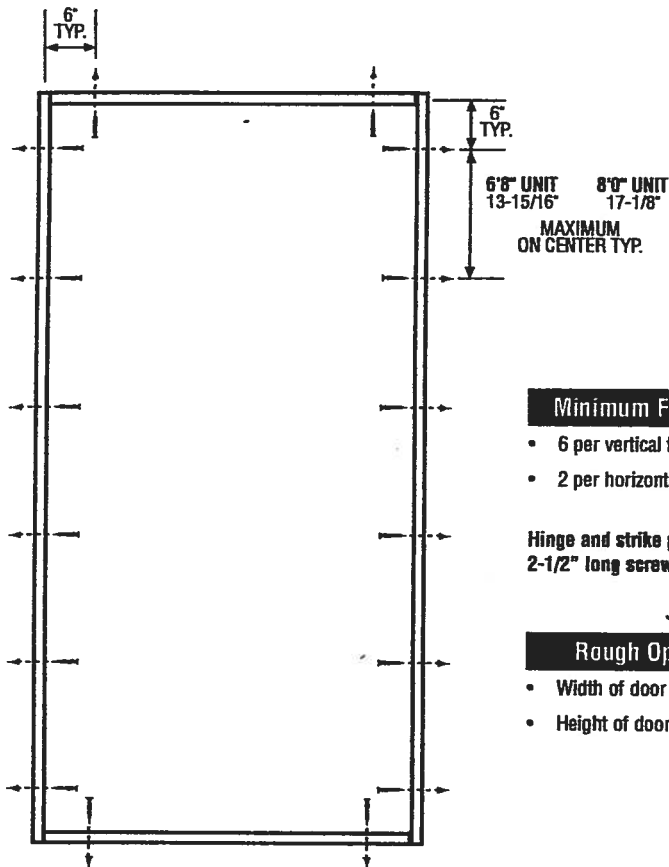

Minimum Fastener Count

- 6 per vertical framing member
- 2 per horizontal framing member

Hinge and strike plates require two 2-1/2" long screws per location.

Rough Opening (RO)

- Width of door unit plus 1/2"
- Height of door unit plus 1/4"

Wilmock-Hensley Test Data Review Certificate #3026447A; #3026447B; #3026447C and COP/Test Report Validation Matrix #3026447A-001, 002, 003; #3026447B-001, 002, 003; #3026447C-001, 002, 003 provides additional information - available from the ITS/WH website (www.itswh.com), the Masonite website (www.masonite.com) or the Masonite technical center.

Latching Hardware:

- Compliance requires that GRADE 3 or better (ANSI/BHMA A156.2) cylindrical and deadlock hardware be installed.
- **UNITS COVERED BY COP DOCUMENT 3146, 3166, 3241*, 3246, 3261* or 3266**
Compliance requires that 8" GRADE 1 (ANSI/BHMA A156.16) surface bolts be installed on latch side of active door panel -- (1) at top and (1) at bottom.

*Based on required Design Pressure -- see COP sheet for details.

Notes:

1. Anchor calculations have been carried out with the lowest (least) fastener rating from the different fasteners being considered for use. Fasteners analyzed for this unit include #8 and #10 wood screws or 3/16" Tapcons.
2. The wood screw single shear design values come from Table 11.3A of ANSI/AF & PA NDS for southern pine lumber with a side member thickness of 1-1/4" and achievement of minimum embedment. The 3/16" Tapcon single shear design values come from the ITW and ELCO Dade County approvals respectively, each with minimum 1-1/4" embedment.
3. Wood bucks by others, must be anchored properly to transfer loads to the structure.

INSWING UNIT WITH SINGLE DOOR

TYPICAL HINGE ATTACHMENT

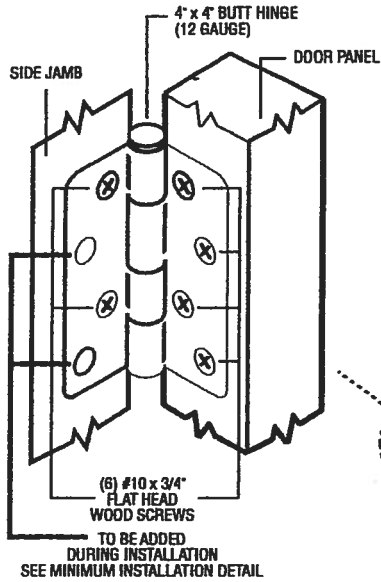

TYPICAL HEADER & SIDE JAMB ATTACHMENT

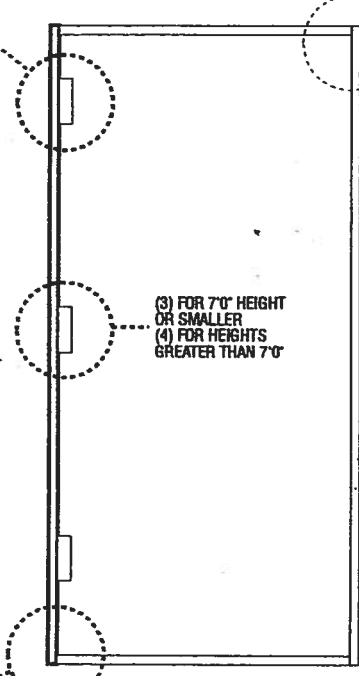
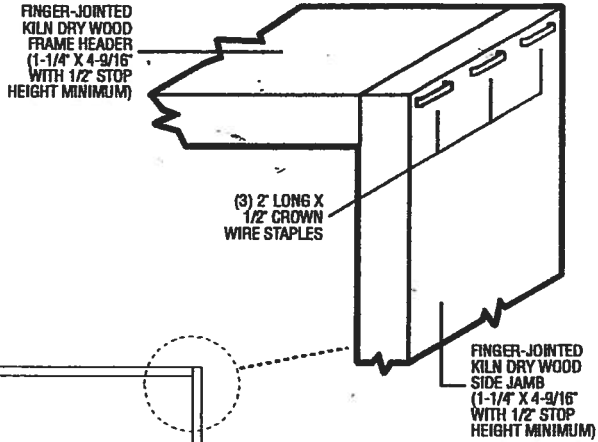

TYPICAL THRESHOLD & SIDE JAMB ATTACHMENT

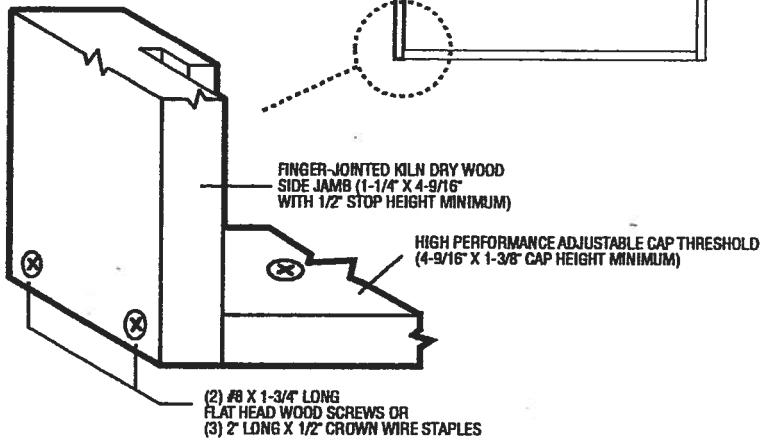

Test Data Review Certificate
#3026447A; #3026447B;
#3026447C and COP/Test Report
Validation Matrix #3026447A-001,
002, 003; #3026447B-001, 002,
003; #3026447C-001, 002, 003
provides additional information -
available from the ITS/WH website
(www.etsemko.com), the Masonite
website (www.masonite.com) or
the Masonite technical center.

X

Opaque Inswing Unit

COP-WL-JH4101-02

WOOD-EDGE STEEL DOORS

CERTIFIED TEST REPORTS:

NCTL 210-2185-1, 2, 3

Certifying Engineer and License Number: Barry D. Portney, P.E. / 16258.

Unit Tested in Accordance with Miami-Dade BCCO PA201, PA202 and PA203.

Door panels constructed from 26-gauge 0.017" thick steel skins. Both stiles constructed from wood. Top end rails constructed of 0.041" steel. Bottom end rails constructed of 0.021" steel. Interior cavity of slab filled with rigid polyurethane foam core.

Frame constructed of wood with an extruded aluminum threshold.

PRODUCT COMPLIANCE LABELING:

TESTED IN ACCORDANCE WITH
MIAMI-DADE BCCO
PA201, PA202 & PA203

COMPANY NAME
CITY, STATE

To the best of my knowledge and ability the above side-hinged exterior door unit conforms to the requirements of the 2001 Florida Building Code, Chapter 17 (Structural Tests and Inspections).



State of Florida, Professional Engineer
Kurt Balthazor, P.E. – License Number 56533



Test Data Review Certificate #3026447A and COP/Test Report Validation Matrix #3026447A-001 provides additional information - available from the ITS/WH website (www.etlserko.com), the Masonite website (www.masonite.com) or the Masonite technical center.

Johnson™
EntrySystems

June 17, 2002
Our continuing program of product improvement makes specifications, design and product detail subject to change without notice.



Exclusively from
Masonite®

Masonite International Corporation

Floor Plan including:

- | | | |
|-------------------------------------|-------------------------------------|--|
| <input checked="" type="checkbox"/> | <input checked="" type="checkbox"/> | a) Rooms labeled and dimensioned |
| <input checked="" type="checkbox"/> | <input checked="" type="checkbox"/> | b) Shear walls |
| <input checked="" type="checkbox"/> | <input checked="" type="checkbox"/> | c) Windows and doors (including garage doors) showing size, mfg., approval listing and attachment specs. (FBC 1707) and safety glazing where needed (egress windows in bedrooms to be shown) |
| <input type="checkbox"/> | <input type="checkbox"/> | d) Fireplaces (gas appliance) (vented or non-vented) or wood burning with hearth |
| <input type="checkbox"/> | <input type="checkbox"/> | e) Stairs with dimensions (width, tread and riser) and details of guardrails and handrails |
| <input checked="" type="checkbox"/> | <input checked="" type="checkbox"/> | f) Must show and identify accessibility requirements (accessible bathroom) |

Foundation Plan including

- | | | |
|-------------------------------------|-------------------------------------|--|
| <input checked="" type="checkbox"/> | <input checked="" type="checkbox"/> | a) Location of all load-bearing wall with required footings indicated as standard Or monolithic and dimensions and reinforcing |
| <input checked="" type="checkbox"/> | <input checked="" type="checkbox"/> | b) All posts and/or column footing including size and reinforcing |
| <input type="checkbox"/> | <input checked="" type="checkbox"/> | c) Any special support required by soil analysis such as piling |
| <input checked="" type="checkbox"/> | <input checked="" type="checkbox"/> | d) Location of any vertical steel |

Roof System:

- | | | |
|-------------------------------------|-------------------------------------|--|
| <input checked="" type="checkbox"/> | <input checked="" type="checkbox"/> | a) Truss package including: <ol style="list-style-type: none">1. Truss layout and truss details signed and sealed by FI. Pro. Eng.2. Roof assembly (FBC 104.2.1 Roofing system, materials, manufacturer, fastening requirements and product evaluation with wind resistance rating) |
| <input type="checkbox"/> | <input type="checkbox"/> | b) Conventional Framing Layout including: <ol style="list-style-type: none">1. Rafter size, species and spacing2. Attachment to wall and uplift3. Ridge beam sized and valley framing and support details4. Roof assembly (FBC 104.2.1 Roofing systems, materials, manufacturer, fastening requirements and product evaluation with wind resistance rating) |

Wall Sections including

- | | | |
|-------------------------------------|-------------------------------------|---|
| <input checked="" type="checkbox"/> | <input checked="" type="checkbox"/> | a) Masonry wall <ol style="list-style-type: none">1. All materials making up wall2. Block size and mortar type with size and spacing of reinforcement3. Lintel, tie-beam sizes and reinforcement4. Gable ends with rake beams showing reinforcement or gable truss and wall bracing details5. All required connectors with uplift rating and required number and size of fasteners for continuous tie from roof to foundation6. Roof assembly shown here or on roof system detail (FBC 104.2.1 Roofing system, materials, manufacturer, fastening requirements and product evaluation with resistance rating)7. Fire resistant construction (if required)8. Fireproofing requirements9. Shoe type of termite treatment (termicide or alternative method)10. Slab on grade<ol style="list-style-type: none">a. Vapor retardant (6mil. Polyethylene with joints lapped 6 inches and sealed)b. Must show control joints, synthetic fiber reinforcement or Welded fire fabric reinforcement and supports11. Indicate where pressure treated wood will be placed12. Provide insulation R value for the following:<ol style="list-style-type: none">a. Attic spaceb. Exterior wall cavityc. Crawl space (if applicable) |
|-------------------------------------|-------------------------------------|---|

b) Wood frame wall

- 1. All materials making up wall
- 2. Size and species of studs
- 3. Sheathing size, type and nailing schedule
- 4. Headers sized
- 5. Gable end showing balloon framing detail or gable truss and wall hinge bracing detail
- 6. All required fasteners for continuous tie from roof to foundation (truss anchors, straps, anchor bolts and washers)
- 7. Roof assembly shown here or on roof system detail (FBC 1 04.2.1 Roofing system, materials, manufacturer, fastening requirements and product evaluation with wind resistance rating)
- 8. Fire resistant construction (if applicable)
- 9. Fireproofing requirements
- 10. Show type of termite treatment (termicide or alternative method)
 - 11. Slab on grade
 - a. Vapor retardant (6Mil. Polyethylene with joints lapped 6 inches and sealed)
 - b. Must show control joints, synthetic fiber reinforcement or welded wire fabric reinforcement and supports
- 12. Indicate where pressure treated wood will be placed
- 13. Provide insulation R value for the following:
 - a. Attic space
 - b. Exterior wall cavity
 - c. Crawl space (if applicable)

c) Metal frame wall and roof (designed, signed and sealed by Florida Prof. Engineer or Architect)

Floor Framing System:

- a) Floor truss package including layout and details, signed and sealed by Florida Registered Professional Engineer
- b) Floor joist size and spacing
- c) Girder size and spacing
- d) Attachment of joist to girder
- e) Wind load requirements where applicable

Plumbing Fixture layout

Electrical layout including:

- a) Switches, outlets/receptacles, lighting and all required GFCI outlets identified
- b) Ceiling fans
- c) Smoke detectors
 - d) Service panel and sub-panel size and location(s)
- e) Meter location with type of service entrance (overhead or underground)
- f) Appliances and HVAC equipment
- g) Arc Fault Circuits (AFCI) in bedrooms

HVAC information

- a) Manual J sizing equipment or equivalent computation
- b) Exhaust fans in bathroom

Energy Calculations (dimensions shall match plans)

Gas System Type (LP or Natural) Location and BTU demand of equipment

Disclosure Statement for Owner Builders

*****Notice Of Commencement Required Before Any Inspections Will Be Done**

Private Potable Water

- a) Size of pump motor
- b) Size of pressure tank
- c) Cycle stop valve if used

THE FOLLOWING ITEMS MUST BE SUBMITTED WITH BUILDING PLANS

1. **Building Permit Application:** A current Building Permit Application form is to be completed and submitted for all residential projects.
2. **Parcel Number:** The parcel number (Tax ID number) from the Property Appraiser (386) 758-1084 is required. A copy of property deed is also requested.
3. **Environmental Health Permit or Sewer Tap Approval:** A copy of the Environmental Health permit, existing septic approval or sewer tap approval is required before a building permit can be issued.
(386)758-1058 (**Toilet facilities shall be provided for construction workers**)
4. **City Approval:** If the project is to be located within the city limits of the Town of Fort White, prior approval is required. The Town of Fort White approval letter is required to be submitted by the owner or contractor to this office when applying for a Building Permit. (386) 497-2321
5. **Flood Information:** All projects within the Floodway of the Suwannee or Santa Fe Rivers shall require permitting through the Suwannee River Water Management District, before submitting application to this office. Any project located within a flood zone where the base flood elevation (1 00 year flood) has been established shall meet the requirements of Section 8.8 of the Columbia County Land Development Regulations. Any project located within a flood zone where the base flood elevation has not been established (Zone A) shall meet the requirements of Section 8.7 of the Columbia County Land Development Regulations. **CERTIFIED FINISHED FLOOR ELEVATIONS WILL BE REQUIRED ON ANY PROJECT WHERE THE BASE FLOOD ELEVATION (100 YEAR FLOOD) HAS BEEN ESTABLISHED.**
A development permit will also be required. Development permit cost is **\$50.00**
6. **Driveway Connection:** If the property does not have an existing access to a public road, then an application for a culvert permit (**\$25.00**) must be made. If the applicant feels that a culvert is not needed, they may apply for a culvert waiver (**\$50.00**). All culvert waivers are sent to the Columbia County Public Works Department for approval or denial.
7. **911 Address:** If the project is located in an area where the 911 address has been issued, then the proper paperwork from the 911 Addressing Department must be submitted. (386) 752-8787

ALL REQUIRED INFORMATION IS TO BE SUBMITTED FOR REVIEW. YOU WILL BE NOTIFIED- WHEN YOUR APPLICATION AND PLANS ARE APPROVED AND READY TO PERMIT. PLEASE DO NOT EXPECT OR REQUEST THAT PERMIT APPLICATIONS BE REVIEWED OR APPROVED WHILE YOU ARE HERE - TIME WILL NOT ALLOW THIS -PLEASE DO NOT ASK

NOTICE:

ADDRESSES BY APPOINTMENT ONLY!

TO OBTAIN A 9-1-1 ADDRESS THE REQUESTER MUST CONTACT THE COLUMBIA COUNTY 9-1-1 ADDRESSING DEPARTMENT AT (386) 752-8787 FOR AN APPOINTMENT TIME AND DATE:

YOU CAN NOT OBTAIN A NEW ADDRESS OVER THE TELEPHONE. MUST MAKE AN APPOINTMENT!

THE ADDRESSING DEPARTMENT IS LOCATED AT 263 NW LAKE CITY AVENUE (OFF OF WEST U.S. HIGHWAY 90 WEST OF INTERSTATE 75 AT THE COLUMBIA COUNTY EMERGENCY OPERATIONS CENTER).

THE REQUESTER WILL NEED THE FOLLOWING:

1. THE PARCEL OR TAX ID NUMBER (SAMPLE: "25-4S-17-12345-123" OR "R12345-123) FOR THE PROPERTY.
2. A PLAT, PLAN, SITE PLAN, OR DRAWING SHOWING THE PROPERTY LINES OF THE PARCEL.
 - a. LOCATION OF PLANNED RESIDENT OR BUSINESS STRUCTURE ON THE PROPERTY WITH DISTANCES FROM TWO OF THE PROPERTY LINES TO THE STRUCTURE (SEE SAMPLE BELOW).
 - b. LOCATION OF THE ACCESS POINT (DRIVEWAY, ETC.) ON THE ROADWAY FROM WHICH LOCATION IS TO BE ADDRESSED WITH A DISTANCE FROM A PARALLEL PROPERTY LINE AND OR PROPERTY CORNER (SEE SAMPLE BELOW).
 - c. TRAVEL OF THE DRIVEWAY FROM THE ACCESS POINT TO THE STRUCTURE (SEE SAMPLE BELOW).

SAMPLE:

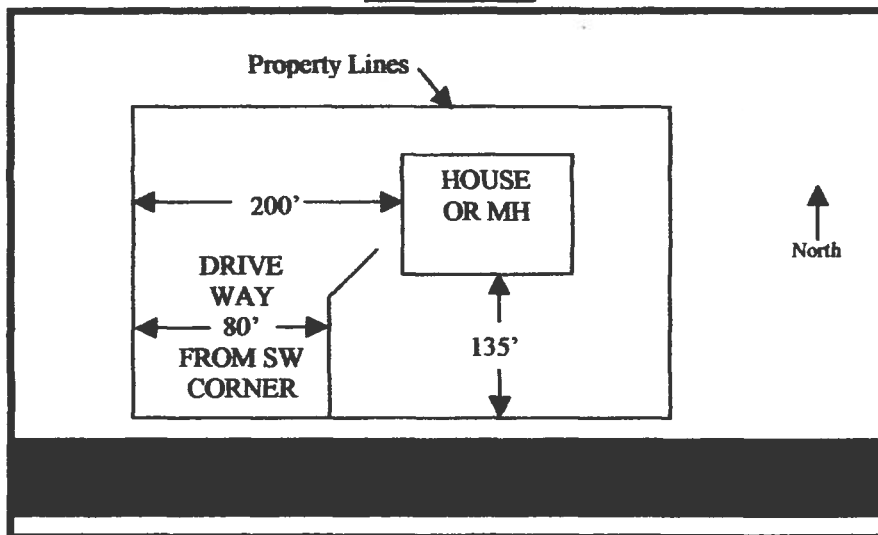

NOTE: 5 TO 7 WORKING DAYS MAY BE REQUIRED IF ADDRESSING DEPARTMENT NEEDS TO CONDUCT AN ON SITE SURVEY.

Notice of Treatment

Applicator: Florida Pest Control & Chemical Co. (www.flapest.com)

Address: 536 SE BAYA DR.

City Lake City Phone 752-1703

Site Location: Subdivision Stonehenge

Lot # 5 Block# _____ Permit # 24754

Address 117 SW Amesbury Court

| <u>Product used</u> | <u>Active Ingredient</u> | <u>% Concentration</u> |
|---|----------------------------------|------------------------|
| <input type="checkbox"/> Premise | Imidacloprid | 0.1% |
| <input type="checkbox"/> Termidor | Fipronil | 0.12% |
| <input checked="" type="checkbox"/> Bora Care | Disodium Octaborate Tetrahydrate | 23.0% |

Type treatment: Soil Wood

| <u>Area Treated</u> | <u>Square feet</u> | <u>Linear feet</u> | <u>Gallons Applied</u> |
|---------------------|--------------------|--------------------|------------------------|
| <u>MAIN BODY</u> | <u>1924</u> | <u>783</u> | <u>4.5</u> |
| _____ | _____ | _____ | _____ |
| _____ | _____ | _____ | _____ |
| _____ | _____ | _____ | _____ |

As per Florida Building Code 104.2.6 – If soil chemical barrier method for termite prevention is used, final exterior treatment shall be completed prior to final building approval.

If this notice is for the final exterior treatment, initial this line _____.

10-30-06 1200 Gunny Parker
Date Time Print Technician's Name

Remarks: Formaldehyde left in shower

Applicator - White Permit File - Canary Permit Holder - Pink



**NICHOLAS
PAUL
GEISLER**
ARCHITECT
N.C.A.R.B. Certified

■ 1758 NW Brown Road
■ Lake City, FL 32055
■ 386/755-9021

03 JULY 2006

JOHNNY KEARSE, BUILDING OFFICIAL
COLUMBIA COUNTY, BUILDING DEPT.
COLUMBIA COUNTY COURTHOUSE ANNEX
LAKE CITY, FLORIDA 32055

RE: SPEC HOUSE FOR DONNIE WILLIAMS CONSTRUCTION
STONEHENGE S/D PHASE 2, LOT: 20
PLAN REVIEW Nr.: 0606-101

DEAR SIR:

PLEASE BE ADVISED OF THE FOLLOWING ADDITION TO THE CONSTRUCTION
DOCUMENTS FOR THE ABOVE REFERENCED PROJECT:

GARAGE DOOR HEADER:
PROVIDE AND INSTALL A 3 1/2" X 15" GLU-LAM BEAM AT THE GARAGE
DOOR HEADER AS MANUFACTURED BY "ANTHONY POWER BEAM",
SUPPORTED EA. END WITH 3 JACK STUDS.

SHOULD YOU HAVE ANY FURTHER QUESTIONS WITH THIS, PLEASE CALL FOR
ASSISTANCE.

YOURS TRULY,
NICHOLAS PAUL GEISLER, ARCHITECT AR0001005

1. Please show on the plans a summary of the square footage of the structure detailing: HVAC area sq.ft. (Living area)
 - Porches & patios area sq.ft.
 - Carport or garages the area sq.ft.
 - Total area under roof area sq.ft.
2. Line 6, conditioned area square footage on form 600A-2004 of the Florida Energy Efficiency Code for Building Construction doesn't concur with the conditioned floor area submitted on the building permit application. The total conditioned areas on the building permit application 1955 (square feet). Line 6 of the Energy Efficiency Code for Building Construction currently reads that the conditioned floor area equals 1924 (square feet). *Please correct and resubmit the form to reflect on line 6 the actual total conditioned area to this department..*
3. The electrical plan shows the location of the electrical service, Please indicate on the electrical plan that an overcurrent protection device will be installed on the exterior of structures to serve as a disconnecting means. Conductors used from the exterior disconnecting means to a panel or sub panel shall have four-wire conductors, of which one conductor shall be used as an equipment ground.
4. Please indicate on the floor plans that the Garage area will comply with the FRC-2004 Sections R309 R309.1 Opening protection: Openings from a private garage directly into a room used for sleeping purposes shall not be permitted. Other openings between the garage and residence shall be

equipped with solid wood doors not less than 13/8 inches (35 mm) in thickness, solid or honeycomb core steel doors not less than 13/8 inches (35 mm) thick, or 20-minute fire-rated doors.

- 5.** Please have Mr. Geisler show the beam design which will be used to span the Sixteen foot garage door opening as callout in the garage end wall detail drawing on page SD-2.

Joe Haltiwanger

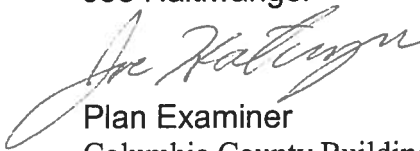

Plan Examiner
Columbia County Building Department

INSTALLATION INSTRUCTIONS ROUGH OPENING

Be sure to Check your window series size for correct call-out size.

FLASHING & INSTALLATION

1. All series of windows rough openings will be call out with exception of series 4300. Series 4300 rough opening requires ½" added to width and height.
2. **SILL:** Cut weather resistant building material (minimum 6" wide) to fit horizontally immediately below the sill extending 6" past each side of rough opening. Apply sealant to top lip of flashing and fasten across top. Leave bottom of sill flashing loose for further wall treatment.
3. **INSTALL WINDOW:** Apply sealant around interior side of nailing fin and to outside joints at each corner of the window. Use shim blocks as necessary to sit window level and square. Fasten with 1 ½" galvanized roofing nails or #8 sheet metal screws no less than 3" from corners and maximum 12" apart. Fasteners must be driven straight into wall, not at angle. Do not use power nailers as they may damage and bow nailing fin. Test opening sash during process.
4. **JAMBS:** Next, cut and apply sealant to edge of 6" weatherproof building material and fasten over window jamb nailing s. Jamb flashing should extend six inches above head and below sill.
5. **HEAD:** Apply sealant and fasten 6" weatherproof building material over window head nailing fin and extending on each side 6" to cover jamb flashing.
6. **NAILING:** Nailing fin is not a water-moisture barrier
7. **COOLING – HEATING:** Vents facing windows can cause excessive condensation to form

FLASHING GUIDE

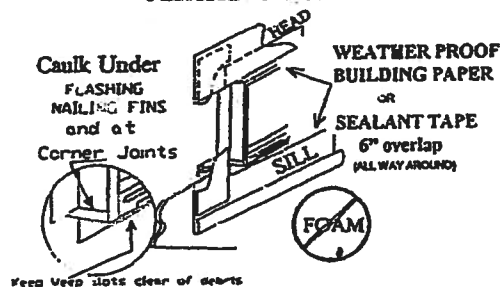

ATTENTION

Action Window Technology recognizes the California Association of Window Manufacturers (CAWM) Practice of Window Installation in Wood Frame Construction.

Proper flashing, or sealing, is necessary as a secondary barrier to stop water from entering between the window frame and rough opening. It is not Action Window Technology's responsibility to design or recommend a flashing system appropriate to each job condition.

The responsibility for properly installing a flashing system into a weather resistant barrier for the entire building is the responsibility of the General Contractor or his agent.

Action Window Technology guidelines do not supercede Federal, State or local codes.

CONSULT WITH LOCAL BUILDING CODES BEFORE INSTALLATION.

Standard)

AAMA/NWWDA 101/I.S. 2-97

Equivalence of Product Standards
Certified By

Product Approval Method

Method 1 Option A

Date Submitted

09/09/2005

Date Validated

11/10/2005

Date Pending FBC Approval

09/29/2005

Date Denied

Summary of Products

| FL # | Model, Number or Name | Description |
|---|-----------------------|---|
| 1788.1 | SERIES 3180 VINYL | BRICK MOLD |
| Limits of Use Approved for use in HVHZ: Approved for use outside HVHZ: Impact Resistant: Design Pressure: +/- Other: SERIES 375 48 X 48 FR-50 SERIES 900 48 X 48 FR-70 SERIES 3180 48 X 72 FR-80 | | Certification Agency Ce Installation Instruction PTID 1788 R1 I fixed.p Verified By: |
| 1788.2 | SERIES 375 ALUMINIUM | ALUMINUM |
| Limits of Use Approved for use in HVHZ: Approved for use outside HVHZ: Impact Resistant: Design Pressure: +/- Other: SERIES 375 48 X 48 FR-50 SERIES 900 48 X 48 FR-70 SERIES 3180 48 X 72 FR-80 | | Certification Agency Ce Installation Instruction Verified By: |
| 1788.3 | SERIES 900 VINYL | VINYL |
| Limits of Use Approved for use in HVHZ: Approved for use outside HVHZ: Impact Resistant: Design Pressure: +/- Other: SERIES 375 48 X 48 FR-50 SERIES 900 48 X 48 FR-70 SERIES 3180 48 X 72 FR-80 | | Certification Agency Ce Installation Instruction Verified By: |

Back

Next

DCA Administration

CERTIFIED TESTING LABORATORIES

Architectural Division • 7252 Narvoossee Rd. • Orlando, FL 32822
(407) 384-7744 • Fax (407) 384-7751
Web Site: www.ctlarch.com
E-mail: ctlarch.com

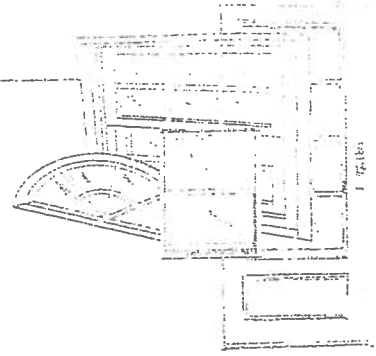

Report Number: CTLA-1038W-2-AWT
Report Date: March 4, 2003

STRUCTURAL PERFORMANCE TEST REPORT

Client: ACTION WINDOOR TECHNOLOGY INC.
1312 W. CROSBY ROAD
CARROLLTON, TX 75006

Product Type and Series: AWT Series 3180 Vinyl Fin Frame Picture Window F-R80 (48" x 72")

Test Specifications: AAMA/NWWDA 101/I.S.2-97 "Voluntary Specifications for Aluminum, Vinyl (PVC) and Wood Windows and Glass Doors"

Frame: Vinyl Fin frame measured 47.50" wide x 71.50" high overall. Mitered corner weld construction. Clear lite measured 44.50" wide x 68.50" high.

Ventilator: N/A

Weather Stripping: N/A
Hardware & Location: N/A

Glazing: 3/4" insulated annealed glass consisting of .1875" glass .375" air space with swiggle .1875" glass. Sash exterior glazed. Fixed lite interior glazed adhesive foam strip backbedding and vinyl snap in glazing bead.

Sealant: A silicone type sealant was used at frame corners and to seal specimen to test buck.

Weep System: N/A
Muntins: N/A

Reinforcement: N/A

Additional Description: N/A
Screen: N/A

Installation: Twenty-eight (28) 1.75" roofing nails were used to secure the specimen to the wood test buck. Six (6) were located in head and sill measuring 5.50", 13", 20.625", 28.25", 35.875" and 43.50" from left jamb. Eight (8) were located in each jamb measuring 5.50", 14", 22.75", 31.50", 40", 48.75", 57.75" and 66.50" from sill.

Surface Finish: White Vinyl

Comment: Nominal 2 mil polyethylene film was used to seal against air leakage during structural loads. The film was used in a manner that did not influence the test results.

Performance Test Results

| <u>Paragraph No</u> | <u>Title of Test</u> | <u>Method</u> | <u>Measured</u> | <u>Allowed</u> |
|--|--|---|-------------------------|-------------------------|
| 2.1.2 | Air Infiltration @1.57 psf | ASTM E283-91 | .02 cfm/ft ² | .34 cfm/ft ² |
| The tested specimen meets or exceeds the performance levels specified in AAMA/NWWDA 101/I.S.2-97. Results recorded in two (2) decimals at the clients request. | | | | |
| 2.1.3 | Water Resistance @ 5.0 gph/ft ² | ASTM E547-93 Four (4) five (5) minute cycles | No Entry | No Entry |
| | WTP= 13.5 psf | ASTM E331-93 Fifteen (15) minute duration | No Entry | No Entry |
| 2.1.4.2 | Uniform Load Structural Permanent Deformation @ 120 psf positive @ 120 psf negative | ASTM E330-90 Ten (10) second load | Neg. Neg. | .192" .192" |
| 2.1.7 | Welded Corner Test | AAMA/NWWDA 101/ IS2-97 | Passed | |
| 2.1.8 | Forced Entry Resistance Test D Window Assemblies This specimen as tested complies to a grade 10-T ¹ =5 minutes Tools used: A spatula (10.1.1.1) and a piece of stiff wire (10.1.3.2) | ASTM F 588-97 | Passed | |

Standard)

AAMA/NWWDA 101/I.S.2-97

Equivalence of Product Standards
Certified By

Product Approval Method

Method 1 Option A

Date Submitted

09/09/2005

Date Validated

11/14/2005

Date Pending FBC Approval

09/29/2005

Date Denied

| Summary of Products | | |
|---|-----------------------|---|
| FL # | Model, Number or Name | Description |
| 1782.1 | SERIES 2000 ALUMINUM | ALUMINIUM |
| Limits of Use Approved for use in HVHZ: Approved for use outside HVHZ: Impact Resistant: Design Pressure: +/- Other: SERIES 2000 ALUMINUM-44 X 72 R55 SERIES 2000 ALUMINUM-47 X 71 R40 SERIES 4300 44 X 72 H-R30 SERIES 4300 44 X 72 H- R35 (MODIF) SERIES 3950 44 X 60 H-R40 | | Certification Agency Ce Installation Instruction PTID 1782 R1 I singlel Verified By: |
| 1782.2 | SERIES 3950 VINYL | BRICK MOLD |
| Limits of Use Approved for use in HVHZ: Approved for use outside HVHZ: Impact Resistant: Design Pressure: +/- Other: SERIES 2000 ALUMINUM-44 X 72 R55 SERIES 2000 ALUMINUM-47 X 71 R40 SERIES 4300 44 X 72 H-R30 SERIES 4300 44 X 72 H- R35 (MODIF) SERIES 3950 44 X 60 H-R40 | | Certification Agency Ce Installation Instruction Verified By: |
| 1782.3 | SERIES 4300 VINYL | VINYL |
| Limits of Use Approved for use in HVHZ: Approved for use outside HVHZ: Impact Resistant: Design Pressure: +/- Other: SERIES 2000 ALUMINUM-44 X 72 R55 SERIES 2000 ALUMINUM-47 X 71 R40 SERIES 4300 44 X 72 H-R30 SERIES 4300 44 X 72 H- R35 (MODIF) SERIES 3950 44 X 60 H-R40 | | Certification Agency Ce Installation Instruction Verified By: |

CERTIFIED TESTING LABORATORIES

Architectural Division • 7252 Narcoossee Rd. • Orlando, FL 32822
(407) 384-7744 • Fax (407) 384-7751
Web Site: www.ctlarch.com
E-mail: ctlarch.com

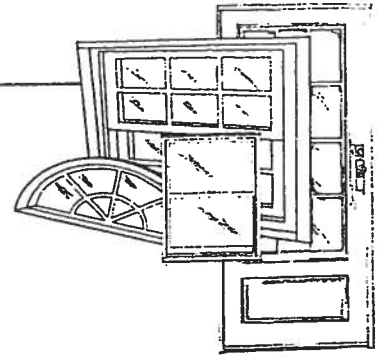

Report Number: CTLA-991W-1-AWT
Report Date: February 18, 2003

STRUCTURAL PERFORMANCE TEST REPORT

Client: ACTION WINDOOR TECHNOLOGY INC.
1312 W. CROSBY ROAD
CARROLLTON, TX 75006

Product Type and Series: AWT Series 3950 Vinyl Fin Frame Single Hung Window with Reinforced Sash Top Rail, Stiles & Meeting Rail H-R40 (36" x 72")

Test Specifications: AAMA/NWWDA 101/I.S.2-97 "Voluntary Specifications for Aluminum, Vinyl (PVC) and Wood Windows and Glass Doors"

Frame: Vinyl Fin frame measured 35.50" wide x 71.50" high overall. Mitered corner weld construction. Fixed meeting rail secured to each frame jamb with one (1) #8 x 2" PH., PH. screw.

Ventilator: Operable sash measured 33.375" wide x 35.25" high overall. Mitered corner weld construction. Clear lite measured 31.5625" high x 33.5625" high. Fixed lite measured 32.50" wide x 33.4375" high.

Weather Stripping: One (1) strip of woolpile .220" high with integral plastic fin frame sill. One (1) strip of woolpile .250" high with integral plastic fin sash top rail exterior. One (1) strip of woolpile .250" high each sash stile exterior leg. One (1) strip of woolpile .250" high with integral plastic fin each sash stile interior leg. One (1) strip of foam filled bulb weatherstrip sash bottom rail.

Hardware & Location: Two (2) metallic sweep locks located on sash top rail approx 8" from each end of rail. Two (2) metallic keepers located on fixed meeting rail. One (1) tilt latch at each end of sash top rail. One (1) block and tackle at each frame jamb. One (1) pivot bar at each end of sash bottom rail.

Glazing: 5/8" insulated annealed glass consisting of .125" glass .375" air space with swiggle .125" glass. Sash exterior glazed. Fixed lite interior glazed adhesive foam strip backbedding and vinyl snap in glazing bead.

Sealant: A silicone type sealant was used on sill and to seal specimen to test buck.

Weep System: Weep notch measuring 2.25" x leg height located each end of sill weeping to the exterior.

Muntins: N/A

Reinforcement: Fixed meeting rail has one (1) piece of extruded aluminum reinforcement measuring .662" wide x .755" high x .099" thick x full length. Top rail, and sash stiles has one (1) piece of extruded aluminum reinforcement measuring .590" wide x .995" high x .115" thick x full length.

Additional Description: N/A

Screen: Roll formed aluminum frame, fiberglass mesh with vinyl spline. Two (2) metallic retainer clips and two (2) metallic plungers. Corners secured with plastic corner keys

Installation: Twenty-six (26) 1.75" roofing nails were used to secure the specimen to the wood test buck. Five (5) were located in head and sill measuring 4", 13", 21", 29", and 33" from left jamb. Eight (8) were located in each jamb measuring 4.50", 14.25", 24", 32.75", 42", 57.25", 60.50" and 70" from sill.

Surface Finish: White Vinyl

Comment: Nominal 2 mil polyethylene film was used to seal against air leakage during structural loads. The film was used in a manner that did not influence the test results.

Performance Test Results

| <u>Paragraph No</u> | <u>Title of Test</u> | <u>Method</u> | <u>Measured</u> | <u>Allowed</u> |
|---|--|---|----------------------------|--------------------------------------|
| 2.1.2 | Air Infiltration @1.57 psf | ASTM E283-91 | .18 cfm/ft ² | .34 cfm/ft ² |
| The tested specimen meets or exceeds the performance levels specified in AAMA/NWWDA 101/I.S.2-97. Results recorded in two (2) decimals at the clients request. Unit tested with shims installed under cam locks. | | | | |
| 2.1.3 | Water Resistance @ 5.0 gph/ft ² | ASTM E547-93 Four (4) five (5) minute cycles | No Entry | No Entry |
| | WTP= 6.75 psf | ASTM E331-93 Fifteen (15) minute duration | No Entry | No Entry |
| Unit tested with insect screen. | | | | |
| 2.1.3 | Water Resistance @ 5.0 gph/ft ² | ASTM E547-93 Four (4) five (5) minute cycles | No Entry | No Entry |
| | WTP= 6 psf | ASTM E331-93 Fifteen (15) minute duration | No Entry | No Entry |
| Unit tested without insect screen. | | | | |
| 2.1.4.2 | Uniform Load Structural Permanent Deformation @ 60 psf positive @ 60 psf negative | ASTM E330-90 Ten (10) second load | .015" .005" | .134" .134" |
| 2.1.8 | Forced Entry Resistance Test A Test B Test C Test D, E and F Test G | AAMA 1302.5-76 | 0" 0" 0" 0" 0" | 1/2" 1/2" 1/2" 1/2" 1/2" |

Performance Test Results (continued)

| <u>Paragraph No</u> | <u>Title of Test</u> | <u>Method</u> | <u>Measured</u> | <u>Allowed</u> |
|---------------------|-------------------------|-------------------------|---------------------|----------------|
| 2.2.2.5.1 | Operating Force Sash | AAMA/NWWDA 101/I.S.2-97 | 18 lbs. | 30 lbs. |
| 2.2.2.5.2 | Deglazing | ASTM E987-88 | | |
| | Top Rail 70 lbs. | | .039" = 7.8% < 100% | |
| | Bottom Rail 70 lbs. | | .038" = 7.6% < 100% | |
| | Left Side 50 lbs. | | .050" = 10% < 100% | |
| | Right Side 50 lbs. | | .035" = 7.0% < 100% | |
| 2.1.7 | Welded Corner Test | AAMA/NWWDA 101/ IS2-97 | | Passed |

Test Date November 21, 2002

Test Completion Date: November 21, 2002

Remarks: Detailed drawings were available for laboratory records and comparison to the test specimen at the time of this report. A copy of this report along with representative sections of the test specimen will be retained by CTL for a period of four (4) years. The results obtained apply only to the specimen tested.

This test report does not constitute certification of this product, but only that the above test results were obtained using the designated test methods and they indicate compliance with the performance requirements (paragraphs as listed) of the above referenced specifications.

Certified Testing Laboratories assumes that all information provided by the client is accurate and that the physical and chemical properties of the components are as stated by the manufacturer.

Certified Testing Laboratories, Inc.

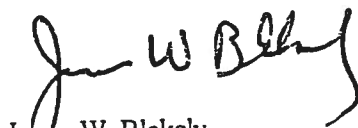

James W. Blakely
Vice President
Architectural Division

cc: Action Window Technology Inc. (3)
 File (1)