

Wind Pressure Summary for C4C Zones based Upon Areas Ch 30 Pt 1 (Table 1 of 3)  
All wind pressures include a load factor of 0.6

Zone	Figure	A <= 2.00 sq ft psf	A = 4.00 sq ft psf	A = 10.00 sq ft psf
1	30.3-2C	11.16 -21.30	10.26 -21.30	9.60 -21.30
2e	30.3-2C	11.16 -21.30	10.26 -21.30	9.60 -21.30
2n	30.3-2C	11.16 -33.99	10.26 -33.99	9.60 -33.99
2r	30.3-2C	11.16 -33.99	10.26 -33.99	9.60 -33.99
3e	30.3-2C	11.16 -33.99	10.26 -33.99	9.60 -33.99
3r	30.3-2C	11.16 -47.93	10.26 -47.93	9.60 -39.65
4	30.3-1	14.96 -16.23	14.96 -16.23	14.96 -16.23
5	30.3-1	14.96 -20.04	14.96 -20.04	14.96 -20.04

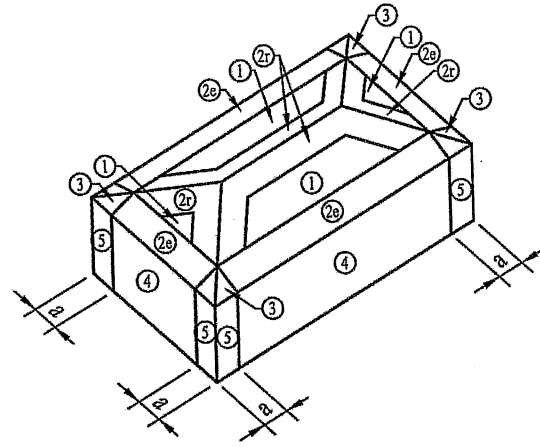

Hip Roof ( $7^\circ \leq \Theta \leq 45^\circ$ )

**PROFESSIONAL SERVICES BY**  
**DRISCOLL ENGINEERING, INC.**  
PO BOX 357577  
GAINESVILLE, FL 32609  
PH (352)-331-1513  
CA 8690

**PLANS AND SPECIFICATIONS**

The plans and specifications presented herein are applicable only for the anticipated construction at the locations shown. If construction plans change, the Design Professional should be notified so the plans and specifications can be re-evaluated. The Design Professional should be given the opportunity to review final plans and specifications to see if the intent of the plans and specifications has been followed and/or if supplemental details and recommendations are needed. The Design Professional warrants that the plans and specifications contained herein, have been prepared in accordance with generally accepted professional engineering practice. No other warranties are implied or expressed.

**CORPORATE PROTECTION**

It is understood and agreed that the Design Professional's Basic Services under this Agreement do not include project observation or review of the Contractor's performance or any other construction phase services, and that such services will be provided by the Client. The Client assumes all responsibility for interpretation of the contractor Documents and for construction observation and supervision and waives any claims against the Design Professional that may be in any way connected thereto.

In addition, the Client agrees, to the fullest extent permitted by law, to indemnify and hold the Design Professional harmless from any loss, claim or cost, including reasonable attorney's fees and costs of defense, arising or resulting from the performance of such services by other person or entities and from any and all claims arising from modifications, clarifications, interpretations, adjustments or changes made to Contract Documents to reflect changed field or other conditions, except for claims arising from the sole negligence or willful misconduct to the Design Professional.

**OWNERSHIP OF INSTRUMENTS OF SERVICE**

All reports, plans, specifications, computer files, field data, notes and other documents and instruments prepared by the Design Professional as instruments of service shall remain the property of the Design Professional. The Design Professional shall retain all common law, statutory and other reserved rights, including the copyright thereto.

**DEFECTS IN SERVICE**

The Client shall promptly report to the Design Professional any defects or suspected defects in the Design Professional's work or services of which the Client becomes aware, so that the Design Professional may take measures to minimize the consequences of such a defect. The Client warrants that he or she will impose a similar notification requirement on all contractors in his or her Client/Contractor contract and shall require all subcontractors at any level to contain a like requirement. Failure by the Client, and the Client's contractors or subcontractors to notify the Design Professional, shall relieve the Design Professional of the costs of remedying the defects above the sum such remedy would have cost had prompt notification been given.

**VERIFICATION OF EXISTING CONDITIONS**

Inasmuch as the remodeling and/or rehabilitation of an existing building requires that certain assumptions be made regarding existing conditions, and because some of these assumptions may not be verifiable without expending additional sums of money or destroying otherwise adequate or serviceable portions of the building, the Client agrees, to the fullest extent permitted by law, to indemnify and hold the Design Professional harmless from any claim, liability or cost (including reasonable attorney's fees and costs of defense) for injury or economic loss arising or allegedly arising out of the professional services provided under this Agreement, excepting only those damages, liabilities, or costs attributable to the sole negligence or willful misconduct of the Design Professional.

**Certification**

I hereby certify that the accompanying wind load analysis for a new residence demonstrates compliance with the FBC 2023 8th Edition Section 1609, to the best of my knowledge.

**Project Wind load Information**

1. Ultimate wind speed = 130 MPH
2. Nominal wind speed = 101 MPH
3. Risk Category = II
4. Wind exposure for this design is Exposure B
5. Interior Pressure Coefficient or Gcpi = +/- 0.18
6. For design of MWFRS: see attached MECAWind Version 2.1.0.6 per ASCE 7-22
7. Roof Design live load 20 psf.
8. Floor Design load 40 psf.

**Drawings**

See drawings for additional details. In case of conflict, the more restrictive requirements of the drawings or these calculations govern.

1. Roof Trusses: Pre-engineered wood roof trusses at 24" o.c. Builders FirstSource . Job# 5152938  
Signed & Sealed truss engineering signed & sealed by Joaquin Velez P.E. # 68182  
Dated: December 23, 2025.
2. Roof Sheathing: Sheathing to be or 15/32" Structural Sheathing or 7/16" osb. min. to adequately resist exterior shear and uplift forces due to nailing. Panels to be facenailed w/ #8 ring shank (0.113 Dia.) @ 6" oc along edges and @ 6" oc along interior supports. Galv. metal edging to be nailed @ 4" oc.
3. Roofing : Metal roof shall be installed per mfg. specifications to meet 130 m.p.h. windloading & in accord with the Florida Building Code 2023.

**Exterior load bearing & shearwalls**

- 1 Studs: Studs: 2 x 4 @ 16" o.c.  
Governing load combination: dead + wind  
Fv D+W = 55 psi  
Fb D-W = 1900 psi  
Use: SPF No. 2 grade or better

2. Shearwall Sheathing Minimum 7/16 structural sheathing, sheathing grade; attach all edges to framing with 8d common nails @ 6" o.c. attach to intermediate framing with 8d common nails @ 12" o.c. Sheathing shall be applied to outside face of all exterior frame walls. Use same nail pattern referenced above for non-shearwall segments also. Note that 8d common nails have a min 0.131 diameter.

See this sheet for shearwalls & holddown locations for Simpson Holddown type & locations.

**Headers**

1. Wood headers @ windows & doors 2- 2"x 12" #2 syp w/ 1/2" osb.
2. Garage door - 2 1.75 x 11-3/4" 2.0E 2500fb LVL in ply

Foundations (sizes based on wind load requirements only :

Monolithic footing: 12" wide x 20" deep w/ 2 #5 bars cont. 25" min lap

thickend slab @ cmu wall 12" wide x 8" deep w/ 1 #5 bar cont.

CONNECTOR SCHEDULE FOR LOAD BEARING & SHEAR WALLS					
TO CONNECT	TO	NO.	PRODUCT CODE	FASTENER	UPLIFT CAPACITY LBS
STUDS	BOTTOM PLATE		H2.5	32" SPACING MAX.	360
STUDS	TOP PLATE		H2.5T	32" SPACING MAX.	535
JACK STUDS	HEADER		CS16	(22 ) 8d COMMON NAILS	1705
JACK STUDS	BOTTOM PLATE		H2.5		360
JACK TRUSS	TOP PLATE		H2.5T		535
TRUSS (uno)	TOP PLATE		H2.5T		535
TRUSS T-03/T-04/ T-13/T-19/T-22			2-HTS24		1245 ea.
GABLE TRUSS	TOP PLATE/ BEAM		LTS 12	@ EACH VERTICAL	
HEADER	WOOD FRAME WALL		H8	8- 8d COMMON	860 EA
BOTTOM PLATE	FOOTING/ SLAB			1/2" DIA.X 12" ANCHOR BOLT W/ 2"X 2" X 1/8" WASHER @ 32" O.C. MAX. & AT EACH BOARD END & OPENING 7" MIN. EMBED	2200
BOTTOM PLATE / WALL	FOOTING/ SLAB		HTT4	1- 5/8" DIA./18-16D COMMON AS SHOWN ON HOLDDOWN LOCATION SHEET	3080

TRUSS T-03/T-04/ T-13/T-19/T-22 BEARING EQUIRES 4- 2"X 6" #2 SYP ATTACH TO CONCRETE W/ DTT2Z

**SHEAR WALLS QUANTITY**  
TRANSVERSAL SHEARWALLS = 69'-0" |  
LONGITUDINAL SHEARWALLS = 80'-0" —

X = SIMPSON HTT4 CONNECTOR

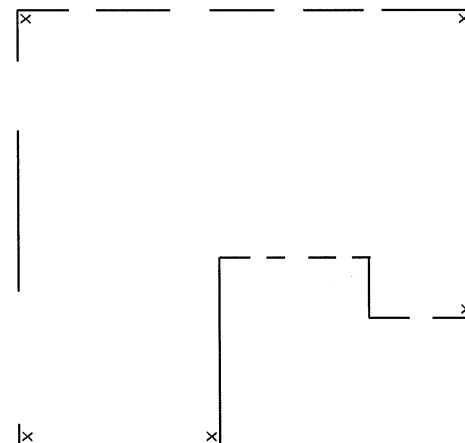

THIS ITEM HAS BEEN ELECTRONICALLY SIGNED AND SEALED BY MICHAEL E. DRISCOLL, P.E. USING A SHA AUTHENTICATION CODE. PRINTED COPIES OF THIS DOCUMENT ARE NOT CONSIDERED SIGNED AND SEALED AND THE SHA AUTHENTICATION CODE MUST BE VERIFIED ON ANY ELECTRONIC COPIES ON 12-30-25

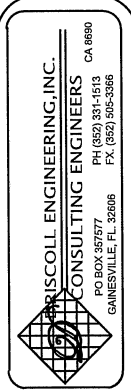

THEIRY  
20107 NW 249th ST  
HIGH SPRINGS, FL DS25-142

DATE: 12-24-25

sheet  
WL 1

MICHAEL E DRISCOLL PE  
FL REG # 43922

THIS ITEM HAS BEEN ELECTRONICALLY SIGNED AND SEALED BY MICHAEL E. DRISCOLL, P.E. USING A SHA AUTHENTICATION CODE. PRINTED COPIES OF THIS DOCUMENT ARE NOT CONSIDERED SIGNED AND SEALED AND THE SHA AUTHENTICATION CODE MUST BE VERIFIED ON ANY ELECTRONIC COPIES ON 12-30-25

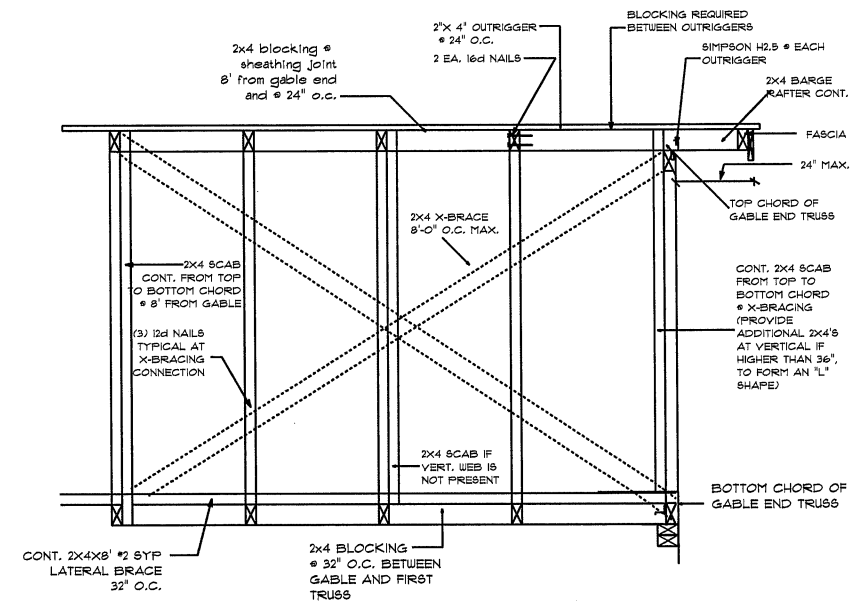

NOTES: 1) Unbraced length of x-bracing may not exceed 10 ft. If length exceeds 10 ft., additional scabs are required.  
2) Siding omitted for clarity.

**FRAMING GABLE END**

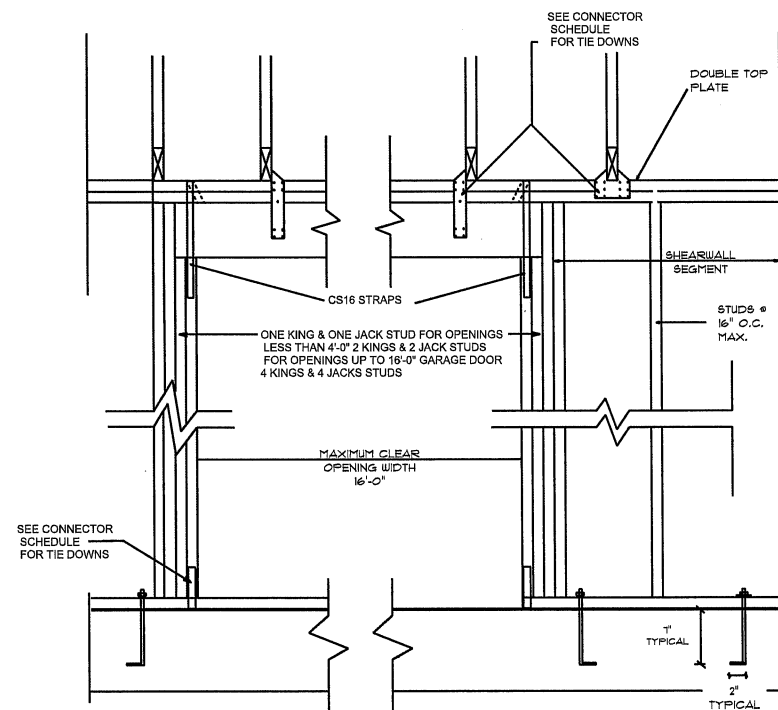

**LOAD BEARING WALL  
OPENING FRAMING DETAIL**

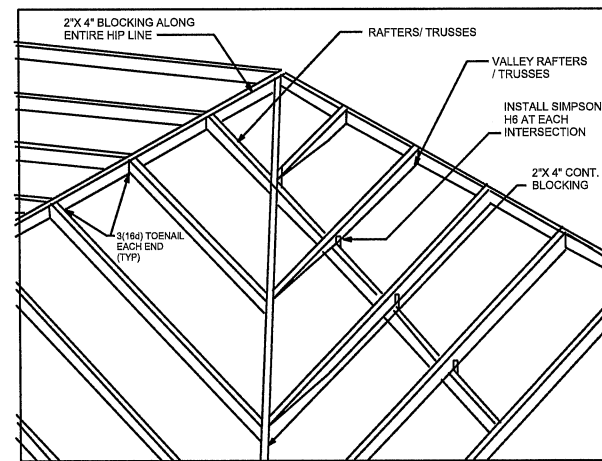

CONTINUOUS 2"x 4" MIN. VALLEY BLOCKING (2) EACH 16d TOENAILS EACH END EACH PIECE. ROOF SHEATHING FROM ADJACENT PLANES TO BE CONNECTED TO COMMON RAFTERS & BLOCKING

SHEATHING MAY BE PROVIDED BETWEEN MAIN ROOF TRUSSES & VALLEY SET TRUSSES

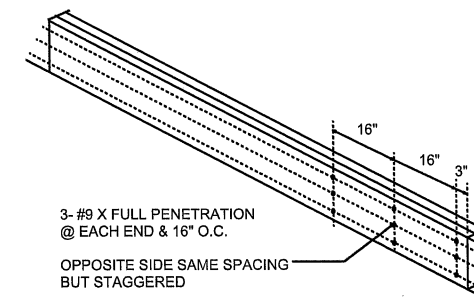

**BEAM LAMINATE  
IF APPLICABLE**

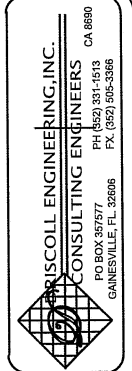

THEIRY  
20107 NW 249th ST  
HIGH SPRINGS, FL DS25-142

DATE: 12-24-25

sheet

WL 2

MICHAEL E DRISCOLL PE  
FL REG # 43922

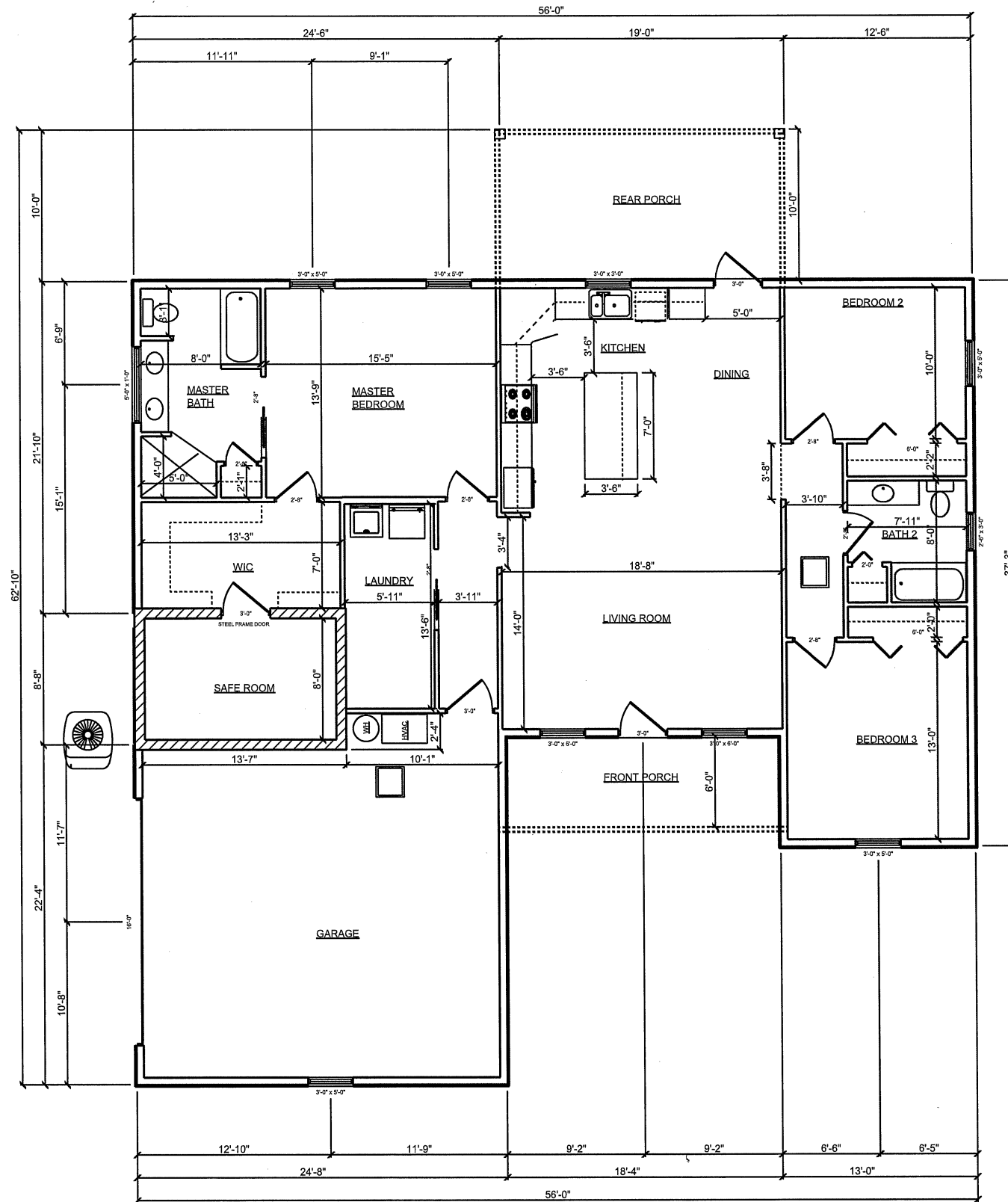

FLOOR PLAN

1. THIS RESIDENCE SHALL BE CONSTRUCTED IN ACCORD WITH THE REQUIREMENTS OF THE FLORIDA BUILDING CODE 2023 8TH EDITION
2. ALL CEILING SHEETROCK SHALL BE MIN 5/8"
3. SEPERATION BETWEEN GARAGE SHALL BE 5/8" SHEETROCK MIN.
4. DOOR SEPERATION GARAGE FROM LIVING AREA SHALL BE 1/2 HR FIRE RATED
5. ALL AREAS EXCEPT WHERE GFI RECEPTALS ARE REQUIRED RECEPTALS SHALL BE ARC FAULT
6. ELECTRICAL DESIGN BY ELECTRICAL CONTRACTOR.
7. CONTRACTOR SHALL VERIFY ALL DIMENSIONS PRIOR TO BEGINNING.
8. SMOKE DETECTORS SHALL BE WIRED TO ALARM SIMUTANIOUS WITH BATTERY BACKUP.

DESIGN CRITERIA	
ULTIMATE WIND SPEED:	130
NOMINAL WIND SPEED:	101
WIND EXPOSURE CATEGORY:	B
RISK CATEGORY	11
INTERIOR PRESSURE COEFFICIENT OR Gcpi=	+/- 0.18
ASSUMED DESIGN LOAD BEARING VALUE OF SOIL	1,500 PSF
FLOOR LIVE LOAD	40 PSF
ROOF LIVE LOAD	20 PSF

LIVING AREA	1768 SQ. FT
FRONT PORCH	157
REAR PORCH	120
GARAGE	572
<b>TOTAL</b>	<b>2617 SQ. FT</b>

THIS ITEM HAS BEEN ELECTRONICALLY SIGNED AND SEALED BY MICHAEL E. DRISCOLL, P.E. USING A SHA AUTHENTICATION CODE. PRINTED COPIES OF THIS DOCUMENT ARE NOT CONSIDERED SIGNED AND SEALED AND THE SHA AUTHENTICATION CODE MUST BE VERIFIED ON ANY ELECTRONIC COPIES ON 12-30-25

- Masonry Construction Notes**
- Concrete masonry work shall conform to "Building Code Requirements for Masonry Structures" (ACI 530-02/ASCE5-02) and "Specifications for Masonry Structures" (ACI 530.1-02/ASCE6-02).
  - Concrete masonry units shall be Type 1 and comply with "Standard Specifications for Hollow Load-Bearing Concrete Masonry Units" (ASTM C90-90).
  - The minimum net area compressive strength of masonry (f<sub>m</sub>), as determined by the unit strength method, shall be 1500 psi.
  - Mortar shall conform to ASTM C270. Type M Mortar shall be used unless otherwise noted. Type S Mortar shall be used with masonry in contact with earth.
  - Masonry column reinforcement shall have #2 ties in the bed joints at 8" oc, unless otherwise noted.
  - Grout for filling block cores and bond beams shall have a minimum compressive strength (f<sub>c</sub>) of 3,000 psi at the age of 28 days.

- Concrete Construction Notes**
- Concrete work shall conform to "Building Code Requirements for Reinforced Concrete" (ACI-318) and "Specifications for Structural Concrete" (ACI-301), Latest Edition.
  - Concrete mix shall conform to the following specifications. All concrete mixes shall contain a water-reducing admixture conforming to ASTM C-494. Air-entraining admixture shall conform to ASTM C-260.
- CONCRETE MIX A**
- |   |           |
|---|-----------|
| Ultimate Compressive Strength @ 28 days | 3,000 PSI |
| Slump Range                             | 4" +/- 1" |
| Maximum Aggregate Size                  | 1"        |
| Entrained Air                           | None      |
| Dry Weight per Cubic Foot               | 150 #     |
- All concrete shall be cured for a minimum of 28 days. If forms for vertical surfaces are removed prior to the end of the curing period, spray surfaces with liquid membrane curing compound.
  - Reinforcing steel shall conform to ASTM A615, Grade 40 (F<sub>y</sub>=40 ksi). Lap continuous bars for tension lap splice per ACI-318, unless otherwise noted. Provide corner bars of same size and spacing as horizontal wall reinforcement. Cover for concrete reinforcing steel shall be in accordance with ACI-318, Paragraph 7.7.
  - Welded wire fabric (WWF) shall conform to ASTM A185. Lap sheets two mesh spaces and wire tie adjacent sheets together securely. Cut alternate reinforcement at control joints.
  - All slabs on grade shall have construction or control joints not to exceed 10' - 0" spacing, unless otherwise noted.
  - Electrical conduit and other pipes to be embedded in structural concrete floor slabs or walls shall be placed in accordance with the requirements of ACI-318, Paragraph 6.3.

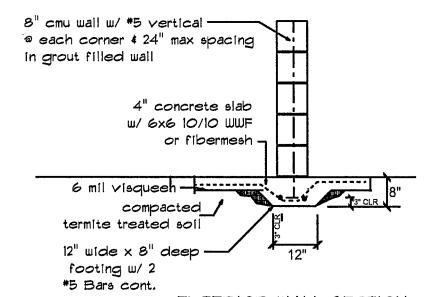

**EXTERIOR WALL SECTION- 4**

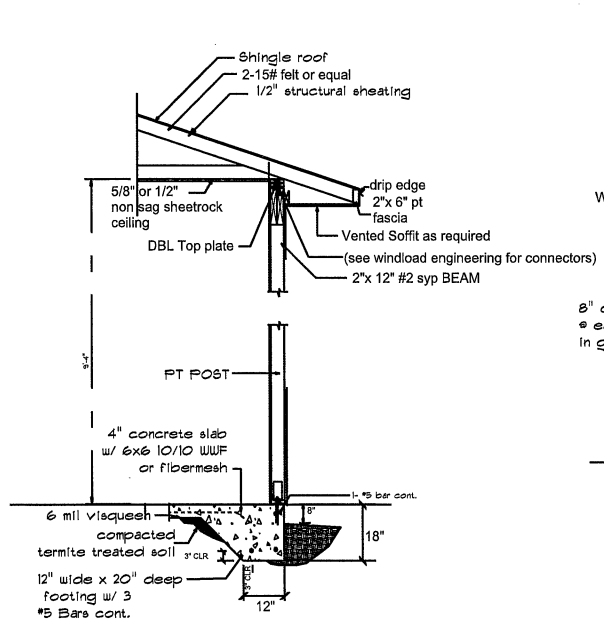

**EXTERIOR WALL SECTION- 2**

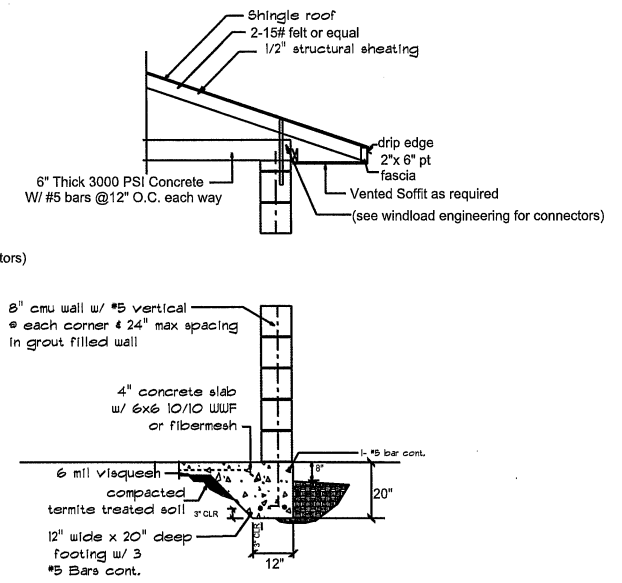

**EXTERIOR WALL SECTION- 3**

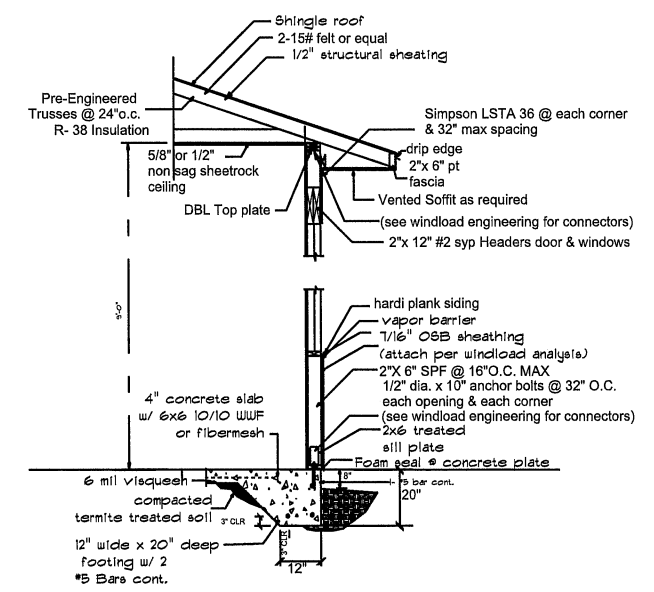

**EXTERIOR WALL SECTION- 1**

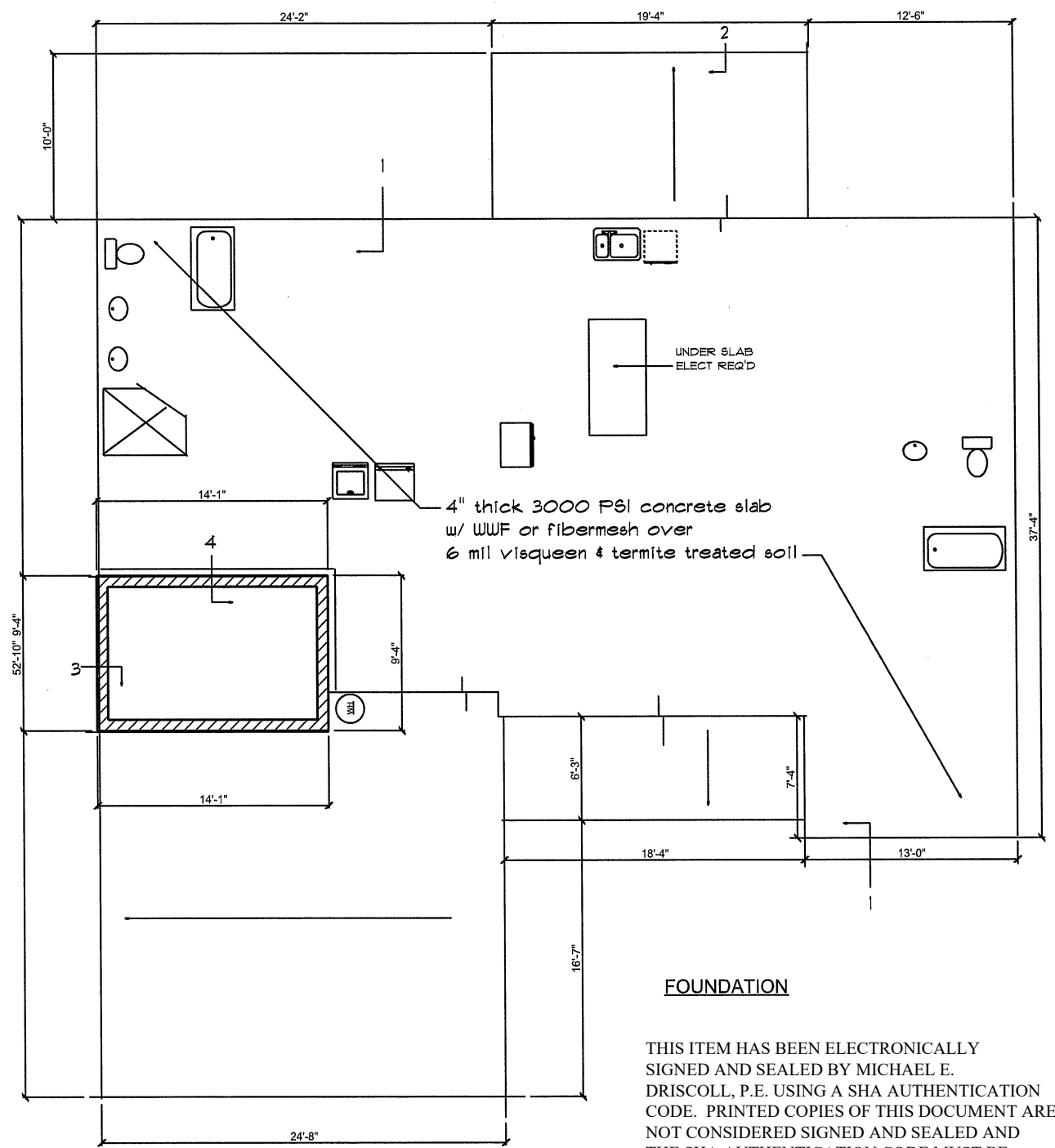

**FOUNDATION**

THIS ITEM HAS BEEN ELECTRONICALLY SIGNED AND SEALED BY MICHAEL E. DRISCOLL, P.E. USING A SHA AUTHENTICATION CODE. PRINTED COPIES OF THIS DOCUMENT ARE NOT CONSIDERED SIGNED AND SEALED AND THE SHA AUTHENTICATION CODE MUST BE VERIFIED ON ANY ELECTRONIC COPIES ON 12-30-25

THEIRY  
20107 NW 249th ST  
HIGH SPRINGS, FL DS25-142

DATE: 12-24-25

sheet  
**2**

THIS ITEM HAS BEEN ELECTRONICALLY  
 SIGNED AND SEALED BY MICHAEL E.  
 DRISCOLL, P.E. USING A SHA AUTHENTICATION  
 CODE. PRINTED COPIES OF THIS DOCUMENT ARE  
 NOT CONSIDERED SIGNED AND SEALED AND  
 THE SHA AUTHENTICATION CODE MUST BE  
 VERIFIED ON ANY ELECTRONIC COPIES ON 12-30-25

VENTILATION	
SQ.FT. OF NEW CEILING	2617/300 = 8.72 SQ.FT
NET FREE AREA / 2	= 4.4 SQ.FT. VENT SYSTEM REQUIRED
EQUALS	634 SQ. IN.
6 OFF RIDGE VENTS	= 660 SQ. IN.
TOTAL TO BE INSTALLED	660 SQ. IN.
SOFIT VENT SYSTEM	4.4 SQ.FT.
DIVIDED BY	0.03226 S.F. PER SQ.FT. OF SOFIT
EQUALS S.F. OF SOFIT PANEL PER SYSTEM	137 SQ.FT.
DIVIDED BY	1.5 = 91 L.F. OF VENTED SOFIT
BUILDING HAS	100+ OF SOFIT AVAILABLE

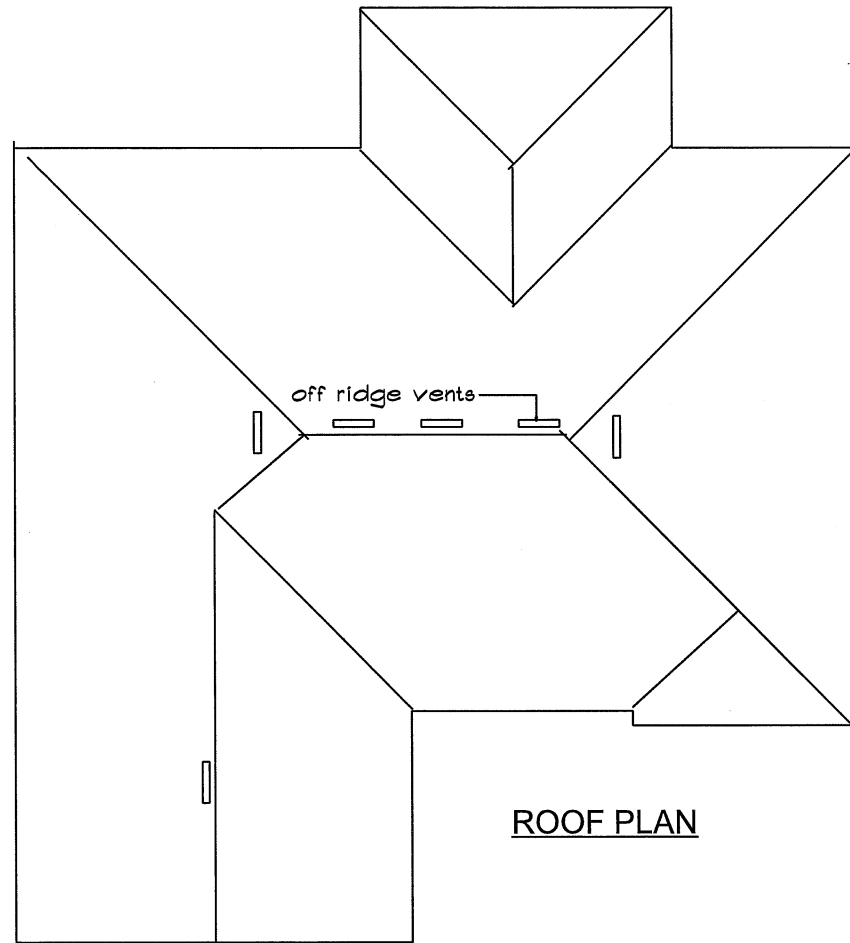

ROOF PLAN

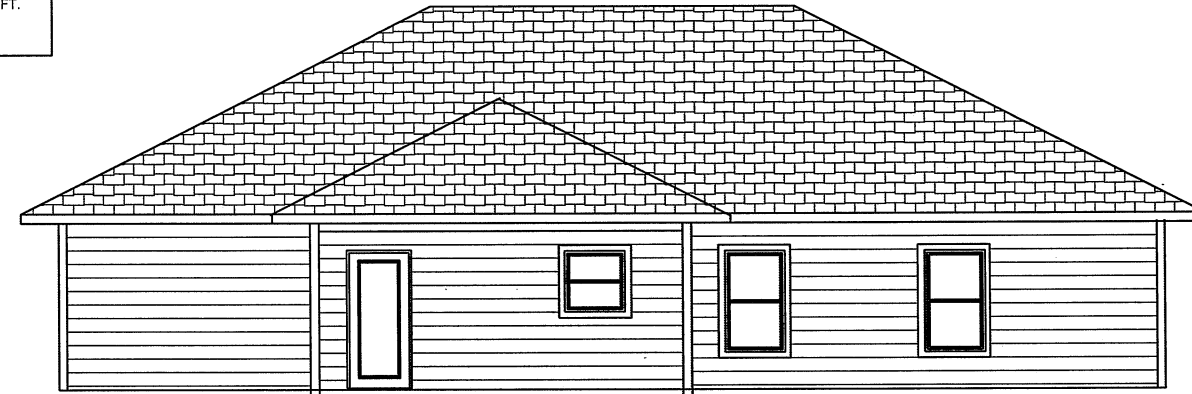

REAR ELEVATION

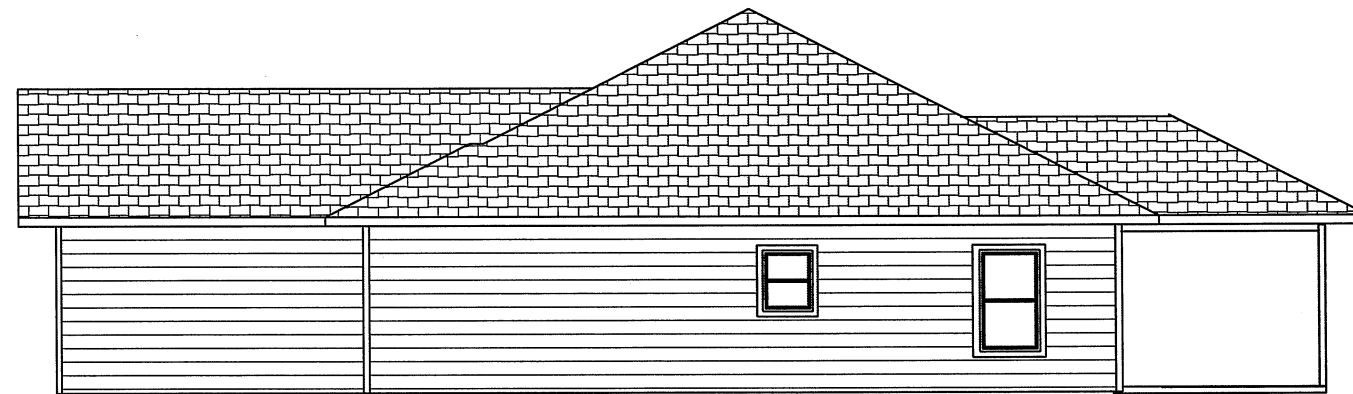

RIGHT ELEVATION

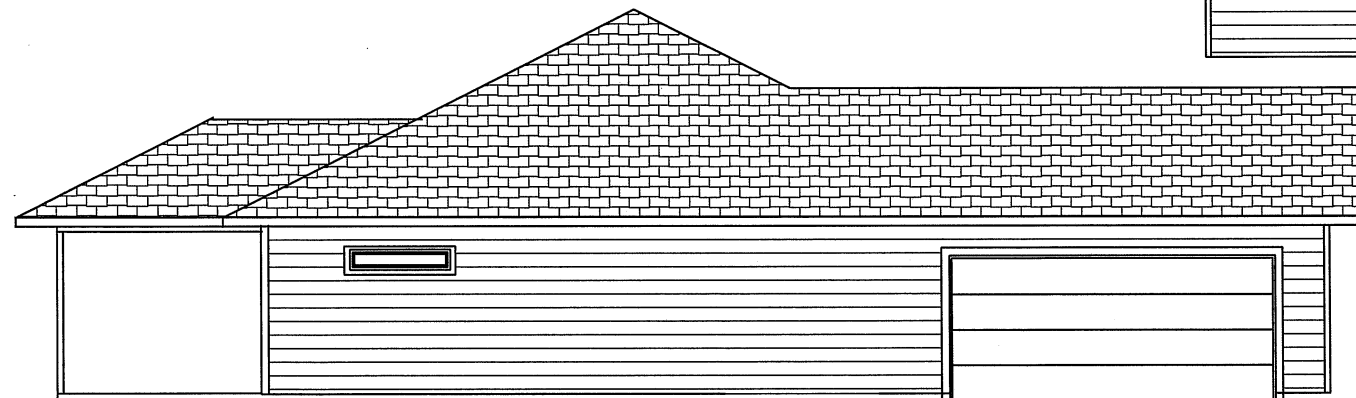

LEFT ELEVATION



FRONT ELEVATION

THEIRY  
 20107 NW 249th ST  
 HIGH SPRINGS, FL DS25-142

DATE: 12-24-25

sheet

3

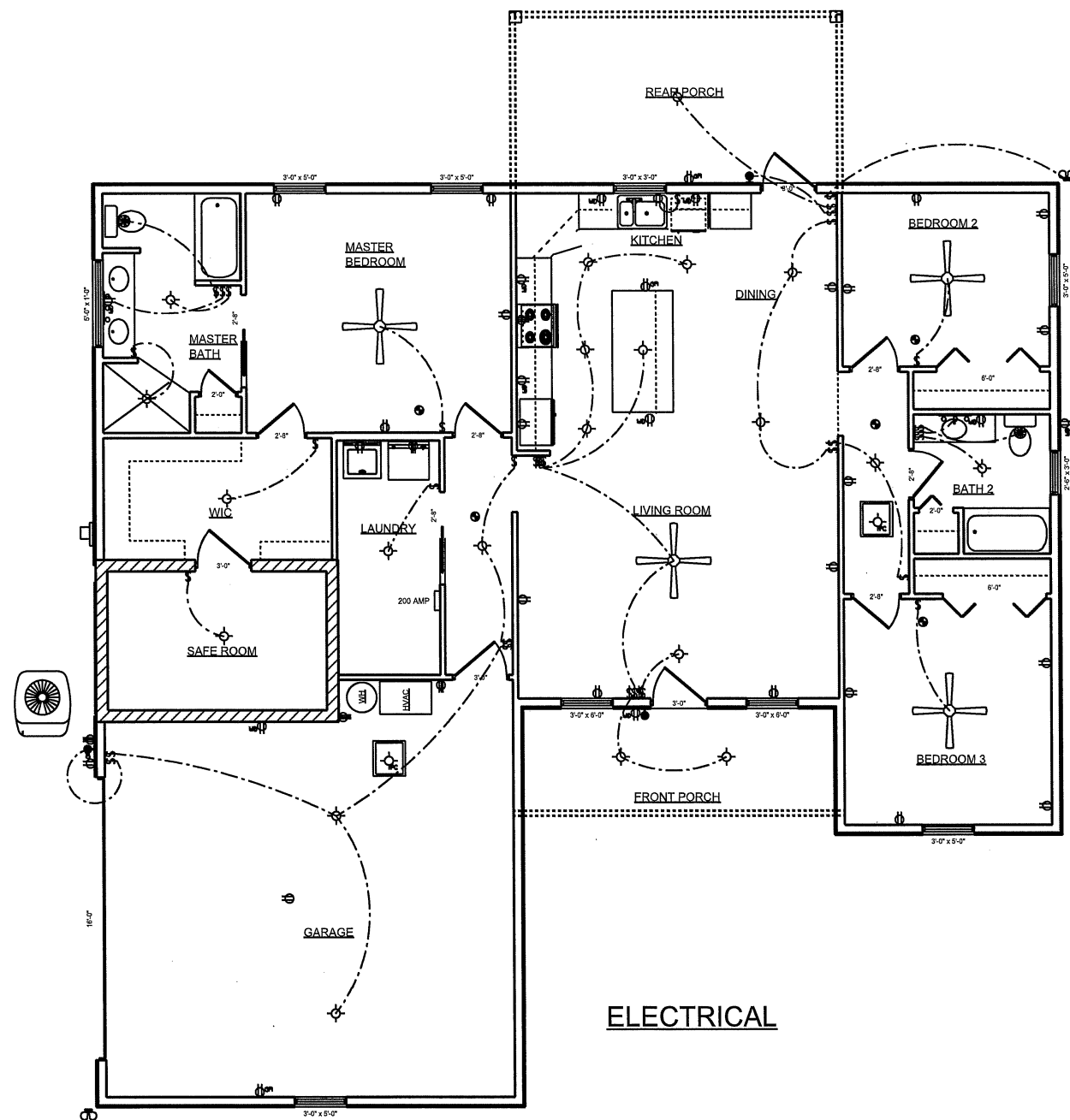

**ELECTRICAL**

Electrical symbols	
[Symbol]	single pole switch
[Symbol]	dimmer switch
[Symbol]	3 way switch
[Symbol]	110 amp fault outlet
[Symbol]	220 OUTLET
[Symbol]	GFI outlet
[Symbol]	switched outlet
[Symbol]	std overhead light
[Symbol]	recessed light
[Symbol]	light / exhaust fan 60 cfm
[Symbol]	wall mount light fixture
[Symbol]	std overhead light
[Symbol]	double flood light
[Symbol]	track bar light
[Symbol]	vanity bar light
[Symbol]	fluorescent light
[Symbol]	ceiling fan -light
[Symbol]	smoke/ CO2 detector
[Symbol]	phone outlet
[Symbol]	tv outlet
[Symbol]	THERMOSTAT

OVERHEAD POWER

sheet DATE: 12-24-25

**E**

THEIRY  
20107 NW 249th ST  
HIGH SPRINGS, FL DS25-142