

# My Favorite Pool Builder

www.myfavoritepoolbuilder.com  
 steve@mfpblc.com  
**CPC1459058**  
**Cell 386-965-0066**

4887 N US Hwy 441  
 Lake City, FL 32055

Toll – Fax 800-286-7929  
 Lake City 386-269-3307  
 Gainesville 382-519-3125  
 Jacksonville 904-248-4196  
 Valdosta, Ga. 229-469-9525  
 Tallahassee 850-296-3622

## Swimming Pool Specification For:

Reginald or Wendy Davis

242 SW Godbold Ave. Lake City, FL 32024

757-752-1401

Property ID - #11-4S-15-00336-019

Page 1	Title Page
Page 2	Deck and Equipment
Page 3	Pool Specifications
Page 4	Energy Efficiency Compliance Data
Page 5	3D pool Images
Page 6	Site Plan information
Page 7	Survey

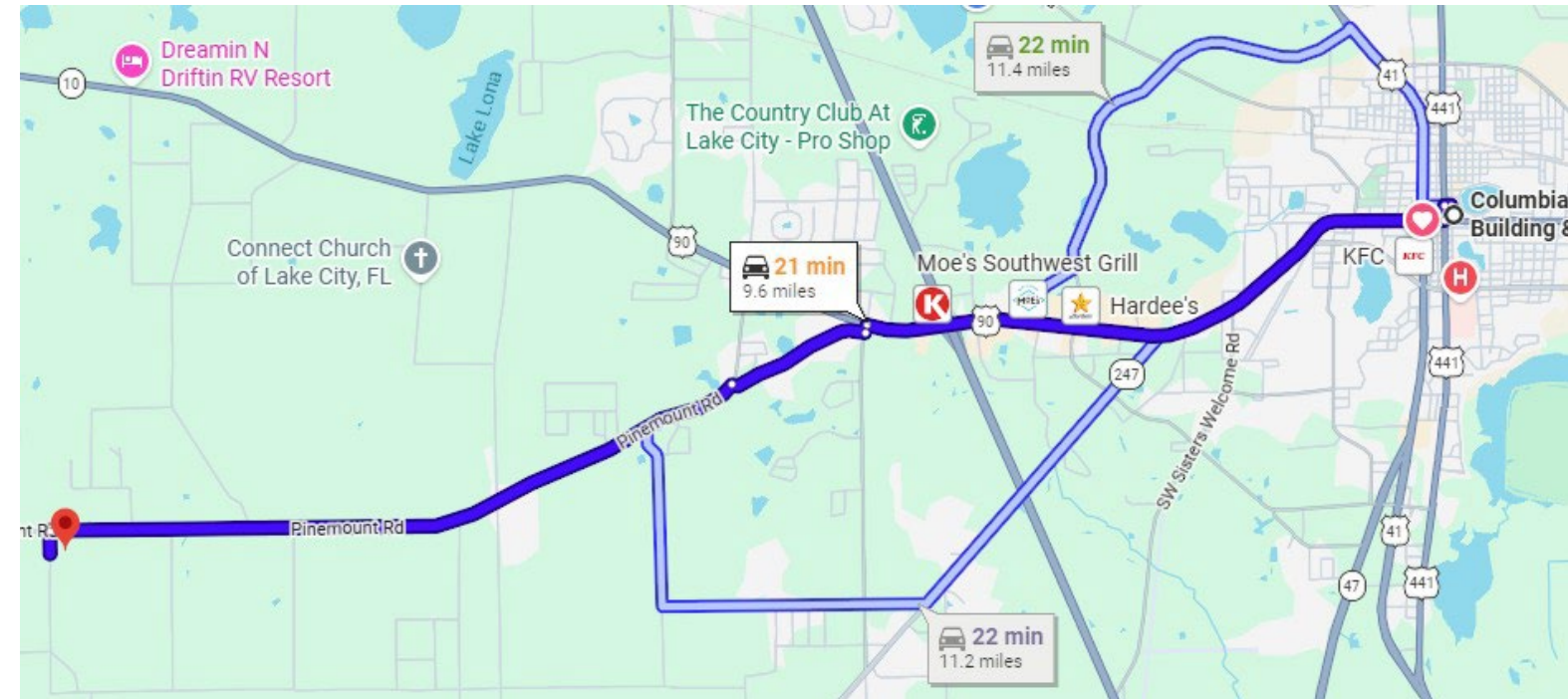

PLAN EXPIRES 1 YEAR FROM THE SIGNATURE DATE OR THE EFFECTIVE DATE OF A MAJOR FLORIDA BUILDING CODE CHANGE WHICHEVER IS SOONER

2/27/2026

My Favorite Pool Builder, Inc.  
 4887 N US Hwy 441  
 Lake City, FL 32055  
 (386) 269-3304 OFF  
 (386) 965-0066 Cell  
 CPC1459058

Swimming Pool Specification For:  
 Reginald or Wendy Davis  
 242 SW Godbold Ave. Lake City, FL 32024  
 757-752-1401

Scale: None Rev  
 Page 1 of 7

**TURNDOWN NOTES ALL MUST MEET FBC 8<sup>th</sup> EDITION**

- Detail is based on NO surcharge behind the Turndown and the Ground away from the Turndown is (>4 to 1) Turndown may abut Ribbon Footer and be tied into Footer if Appropriate, with #3 Rebar (24" Min Lap).
- Turndown shall bear on rock, clean sand or structurally sound soils (1,500 psi) that shall be compacted to provide optimum bearing capacity and prevent settling or shifting
- All Reinforcing steel is to conform to ASTM 615, Grade 40.
- Concrete shall contain Fiber mesh and have a 28 day compressive strength of 2,500 PSI.
- POOL SHALL CONFORM TO REQUIREMENTS**  
**FLORIDA BUILDING CODE, 8<sup>th</sup> EDITION, 2023 (FBC) ACCESSIBILITY, FBC BUILDING; FBC RESIDENTIAL, AND ANSI/APSP/ICC-3, ANSI/APSP/ICC-4, ANSI/APSP/ICC-5, ANSI/APSP/ICC-6 AND ANSI/APSP-7, ANSI/APSP-15, AND THE ADOPTED NATIONAL ELECTRIC CODE 2020 (NEC) AND CHAPTER 42 AND CHAPTER 45 OF THE 8<sup>th</sup> EDITION OF THE FBC, 2023, RESIDENTIAL.**
- Refer to Contractor's Plan on file with the building department for details on Turn down location.
- If the base of the turndown does not extend into the old (existing) ground, a 4" Ø pilaster will be required every 5' 0" that will be either 2' 0" into the ground or to 6" into the indigenous material, whichever is deeper. The pilaster will have a #3 rebar tied to a #5 rebar in the base of the vertical pour.
- A deck turndown is not intended to be substitute for a retaining wall. If the vertical dimension from the top of the concrete deck to the old (existing) ground reaches 42" for a 12" turndown, for more than 20% of the turndown length or the finished grade slope exceeds (steeper than) 4' horizontally and 1' vertically (1 in 4), a turndown shall not be used.
- For a paver deck, if the vertical dimension from the top of the deck to the old (existing) ground reaches 30.0" for a 12" turndown, 36.0" for a 18" turndown, for more than 20% of the turndown length or the finished grade slope exceeds (steeper than) 4' horizontally and 1' vertically (1 in 4), a turndown shall not be used.

**Pump**

Pentair 011075 or better Intelliflo 3HP Variable Speed Pool Pump 2"  
 Pipe  
 Self-Priming  
 230 volt Phase 1 16 amp with timer  
 With Dynamic Head 50  
 750 RPM-GPM Up to 25 Turn over at this speed 6.16 Hours  
 2,350 RPM-GPM Up to 90 Turn Over at this speed 3.19 Hours

**Filter**

Tank Diameter	Filter Area Sq. Ft.	Lbs. of Sand Required	Max Working Pressure (PSI)	Vrtl. Clearance Required	Design Flow Rate GPM	Max Water Temp
16"	1.40	100	30	45"	35	95°F
19"	1.92	150	35	49"	40	95°F
22"	2.64	250	40	55"	60	95°F
24"	3.15	300	50	58"	70	95°F
26"	3.69	350	50	60"	75	95°F

Product #	sq. ft.	Residential Maximum Cartridge Flow Rates				Commercial Maximum Cartridge Flow Rates			
		GPM	GPH	6 hour	8 hour	GPM	GPH	6 hour	8 hour
160314	50	50	3,000	18,000	24,000	19	1,140	6,840	9,120
160315	75	75	4,500	27,000	36,000	28	1,680	10,080	13,440
160316	100	100	6,000	36,000	48,000	38	2,280	13,680	18,240
160317	150	150	9,000	54,000	72,000	56	3,360	20,160	26,880
160318	200	150	9,000	54,000	72,000	75	4,500	27,000	36,000

(1) One GPM per sq. ft. shown, recommended flow rate for residential is .5 GPM per sq. ft.  
 (2) Commercial flow rate is a maximum of .375 GPM per sq. ft. of filter area.  
 NOTE: Actual system flow will depend on plumbing size and other system components.

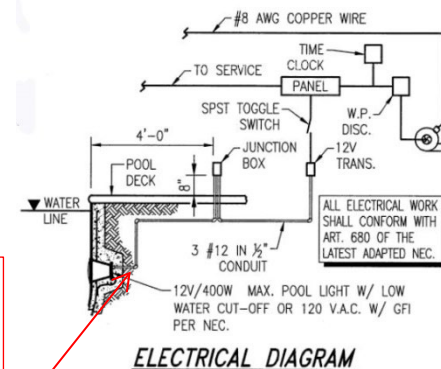
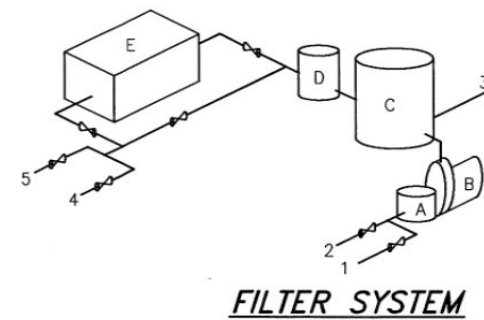

Light for pool is 12 – Volt LED Color powered by transformer

**Footer Notes**

- If a scree enclosure is to be installed, the swimming pool contractor must coordinate the design and construction of any required footer with the screen contractor. Specific details for the footer to be provided by the screen enclosure engineer.
- Footer shall bear on rock, clean sand or structurally sound soils (1,500 psi) that shall be compacted to provide optimum bearing capacity and prevent settling or shifting
- Concrete shall contain Fiber mesh and have a 28 day compressive strength of 2,500 PSI.
- (3) #3 Rebars is equivalent to (1) #5 rebar.
- #3 - #4 - #5 Rebar lap Minimum lap is 24 inches
- A footer must be installed with brick paver pool deck if required by the Jurisdiction or the option of the contractor and may be placed over the top Of the footer or abutting the side of the footer.

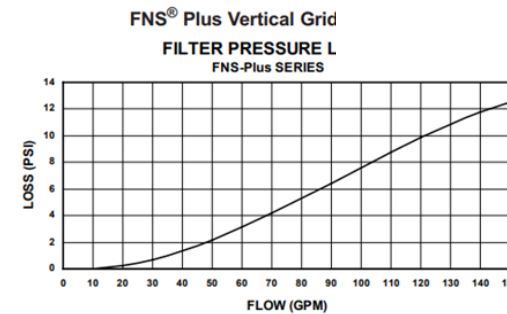
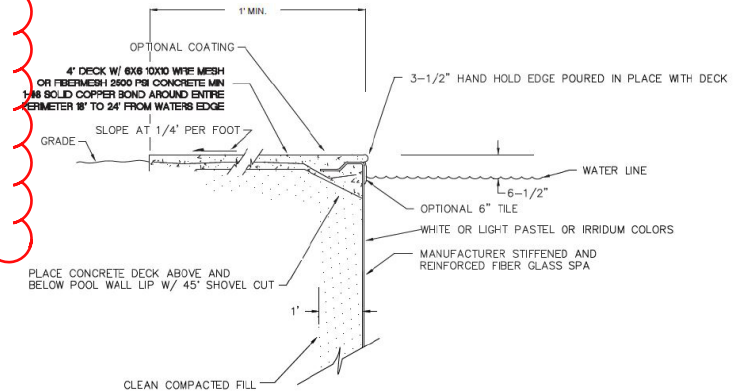
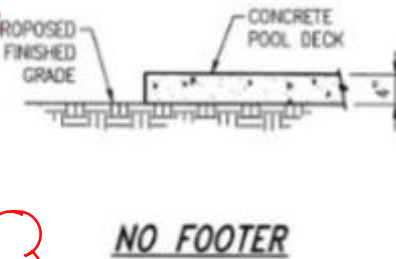
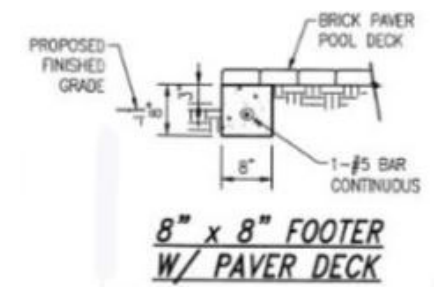
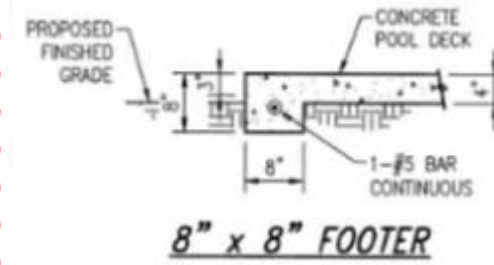

sq.ft.	Height	GPM	GPH	6 hour	8 hour
48	49"	120	7,200	43,200	57,600
60	55"	150	9,000	54,000	72,000

WALL SECTION NOT TO SCALE

**PoolBond PB-2008 Water Bonding Fitting**

**Installed near Pool Equipment**

**Horizontal All Installations**

PLAN EXPIRES 1 YEAR FROM THE SIGNATURE DATE OR THE EFFECTIVE DATE OF A MAJOR FLORIDA BUILDING CODE CHANGE WHICHEVER IS SOONER

2/27/2026



*John Duranko*

My Favorite Pool Builder, Inc.  
 4887 N US Hwy 441  
 Lake City, FL. 32055  
 (386) 269-3304 OFF  
 (386) 965-0066 Cell  
 CPC1459058

Swimming Pool Specification For:  
 Reginald or Wendy Davis  
 242 SW Godbold Ave. Lake City, FL 32024  
 757-752-1401

Scale: None Rev  
 Page 2 of 7

**2020 FBC, 7<sup>TH</sup> EDITION**

**R4510.4.4 Compliance**

All materials, piping, valves, equipment or appliances entering into the construction of swimming pools or portions thereof shall be of a type complying with this code or of a type recommended and approved by a nationally recognized testing agency or conforming to other recognized standards acceptable to the administrative authority.

**454.1.2 Swimming pool construction standards.**

**454.1.2.1 Pool structure.**

Pools shall be constructed of concrete or other impervious and structurally rigid material. All pools shall be watertight, free from structural cracks and shall have a nontoxic smooth and slipresistant finish. All materials shall be installed in accordance with manufacturer's specifications unless such specifications violate Chapter 64E-9, Florida Administrative Code, rule requirements or the approval criteria of NSF/ANSI Standard 50 or NSF/ANSI Standard 60.

**The subject pools are compound of fiberglass shells meeting the requirements. See "FIBERGLASS SHELL REQUIREMENTS"**

**The subject pools meet or exceed all loads prescribed 454.1.2.1 and IRC section 301. All**

**Pool** The construction tolerances for dimension for the overall length width and depth of the pool shall be +/- 3 inches. The construction tolerance is for all other dimension shall be +/- 2 inches, unless otherwise specified by the design engineer. **The subject pool meets the noted construction tolerances. Field installation tolerance should be verified during field inspections.**

**454.2.4.2.1 Flood Hazard Areas – and IRC section 322 - installations in flood Hazard A or V zones require additional hold - down features to be designed in a case-by-case basis.**

**454.1.2.7 Diving Water Envelopes - N/A** The subject pools are non-diving.

**454.1.2.2 Walls and Corners**

Walls in the shallow area and deep areas of the pool should have a wall-to-floor transition point that is less than 33 inches below the design water line. Above the transition point, the wall shall be within 11 degrees of vertical.

**The subject pools have a wall-to-floor transition 41" below the design waterline and the walls are within 6 degrees of vertical.**

**454.1.2.2.3 POOL FLOOR SLOPES** The radius of curvature between the floor and walls is excluded from these requirements. Multiple floor levels in pools are prohibited, however, an area meeting all of the requirements of a sun shelf shall not be considered a violation of this requirement.

**454.1.2.2.3.1** The subject pools have a single 1 unit vertical to 14 unit horizontal slope either meeting or making all the subjects requirements N/A.

**454.1.2.2.4 Pool Depths**

The design water depth as measured at the shallowest point in the shallow area shall be not less than 33 inches and not greater than 4 feet. Shallow area designed in accordance with Section 809.6, 809.7 and 809.8 shall be exempt from the minimum depth requirement. **The subject pools have a minimum depth of 3'- 8" (44")**

**454.1.2.7 Diving Areas**

**N/A** The subject pools are non-diving.

**454.1.9.2.6.1 Water Slides** N/A The subject pools do not include integral slides.

**454.1.2.5 Access** Pool shall have a means of entry and exit in all shallow areas where the design water depth of the shallow area at the shallowest point exceed 24 inches at the shallowest point. Entries and exits shall consist of one or a combination of the following: steps, stairs, ladders, Treads, ramps, Beach entries, underwater seats, benches, swim out and

other prove designs. The means of entry and exit shall be located on the shallow side of the first slope change. Where water depth in the Deep area the pool exceeds 5 feet, a means of entry and exit shall be provided in the deep area of the pool.

**454.1.6.5.9.4** Pool over 30 Foot wide N/A The subject pools are not in excess of 30' in width.

**454.1.2.5.3 Stairs.** Stairs shall have a minimum tread width of 10 inches (254 mm) and a maximum width of 48 inches (1219 mm) for a minimum tread length of 24 inches (610 mm) and a maximum riser height of 10 inches (254 mm). Treads and risers between the top and bottom treads shall be uniform to within 1/2 inch (12.7 mm) in width and height. The riser heights shall be measured at the marked step edges and the differences in elevation shall be considered the riser heights. The front 3/4 to 2 inches (19.1 to 51 mm) of the tread and the top 2 inches (51 mm) of the riser shall be tile, dark in color, contrasting with the interior of the pool. Tile shall be slip resistant.

**Cont..**

**454.1.2.5.3 Stairs** Bullnose tile that is slip resistant may be used when the 3/4-inch (19 mm) segment is placed on the tread or horizontal surface and the 2-inch (51 mm) segment is placed on the riser or vertical surface. Where the gutter is used as the top step, the tile on the gutter for the width of the steps shall be slip resistant. Vinyl liner and fiberglass pools may use other material for the step edge marking, provided the material is permanent, permanently secured, dark in color, nonfading and slip resistant.

**454.1.2.5.4 Swimouts.** Swimouts shall extend 18 (457 mm) to 24 inches (610 mm) back from the pool wall, shall be 4 to 5 feet (1219 mm to 1524 mm) wide, shall be a maximum of 12 inches (305 mm) below the deck, unless stairs are provided in the swimout, and shall be located only in areas of the pool greater than 5 feet (1524 mm) deep. Pools that do not utilize a continuous perimeter overflow system must provide a wall return inlet in the swimout for circulation. A permanent dark contrasting colored band of tile shall be installed at the intersection of the pool wall and the swimout and must extend 2 inches (51 mm) on the horizontal and vertical surfaces. Tile must be slip resistant. Bullnose tile may be substituted and installed in accordance with Section 454.1.2.5.3 above. **The subject pools have an underwater seat in the deep end.**

**454.1.9.6 Zero Depth Entry Pools. (BEACH AND SLOPING ENTRIES)**

**N/A** The subject pools do not include beach and sloping entries.

**TURNOVER RATE**

The circulation system equipment shall be sized to provide a turnover of the pool water not less than once every 12 hours. The system shall be designed to provide the required turnover rate based upon the manufacturer's specified flow rate of the filter, with clean media condition of the filter.

**The subject pools provide a turnover of the pool water not less than once every 12 hours.**

**STRAINER REQUIRED**

Pressure filter system shall be provided with a strainer located between the pool and the circulation pump.

**The subject pools provides a strainer located between the pool and the circulation pump.**

**454.2.17 Residential swimming barrier requirement.**

Residential swimming pools shall comply with Sections 454.2.17.1 through 454.2.17.3. **Exception:** A swimming pool with an approved safety pool cover complying with ASTM F1346.

**454.2.17.1.9** Where a wall of a dwelling serves as part of the barrier, one of the following shall apply:

1. All doors and windows providing direct access from the home to the pool shall be equipped with an exit alarm complying with UL 2017 that has a minimum sound pressure rating of 85 dBA at 10 feet (3048 mm). Any deactivation switch shall be located at least 54 inches (1372 mm) above the threshold of the access. Separate alarms are not required for each door or window if sensors wired to a central alarm sound when contact is broken at any opening.

**Exceptions:**

- a. Screened and protected windows having a bottom sill height of 48 inches (1219 mm) or more measured from the interior finished floor at the pool access level.
  - b. Windows facing the pool on the floor above the first story.
  - c. Screened or protected pass-through kitchen windows 42 inches (1067 mm) or higher with a counter beneath.
2. All doors providing direct access from the home to the pool must be equipped with a selfclosing, self-latching device with positive mechanical latching/locking installed a minimum of 54 inches (1372 mm) above the threshold, which is approved by the authority having jurisdiction.
  3. A swimming pool alarm that, when placed in a pool, sounds an alarm upon detection of an accidental or unauthorized entrance into the water. Such pool alarm must meet and be independently certified to ASTM F2208, titled "Standard Safety Specification for Residential Pool Alarms," which includes surface motion, pressure, sonar, laser, and infrared alarms. For purposes of this paragraph, the term "swimming pool alarm" does not include any swimming protection alarm device designed for individual use, such as an alarm attached to a child that sounds when the child exceeds a certain distance or becomes submerged in water.

**GENERAL CONSTRUCTION NOTES:**

- 1) –Backfill shall have bearing value greater than 60 PSF with Vertical angle of Repose. Back-fill material must not contain rocks that could damage pool walls. Back-fill shall be installed and compacted in lifts to match water level in pool and not deform pool.
- 2) –Therapy seats, where installed, shall be recessed in to the sides of such pool not more than 20 inches below water level, and in such a manner as to clearly distinguish such underwater obstructions from pool areas in to which persons may dive.
- 3) –Swimming pool skimmer(s) shall have deck openings.
- 4) –Electrical hook-up of pool equipment, rails, boxes, etc. and grounding of deck steel shall be in accordance with the National Electrical Code and all applicable state and local building codes by a licensed electrical contractor.
- 5) –Install 12 volt light. When allowed by local code. Higher voltage shall be GFI protected per NEC. At installers option LED or Fiberoptic Lighting may be used..
- 6) –If the slope from shallow end to deep end is more than 1:7 a safety rope shall be provided when required.
- 7) –Supports and steps shall be properly reinforced and of sufficient structural strength to safely carry all anticipated loads.
- 8) –All pipe to be PVC schedule40 suitable for potable water, or to local code.
- 9) –Direct suction pipes from the pool shall have Secondary Reliefs.

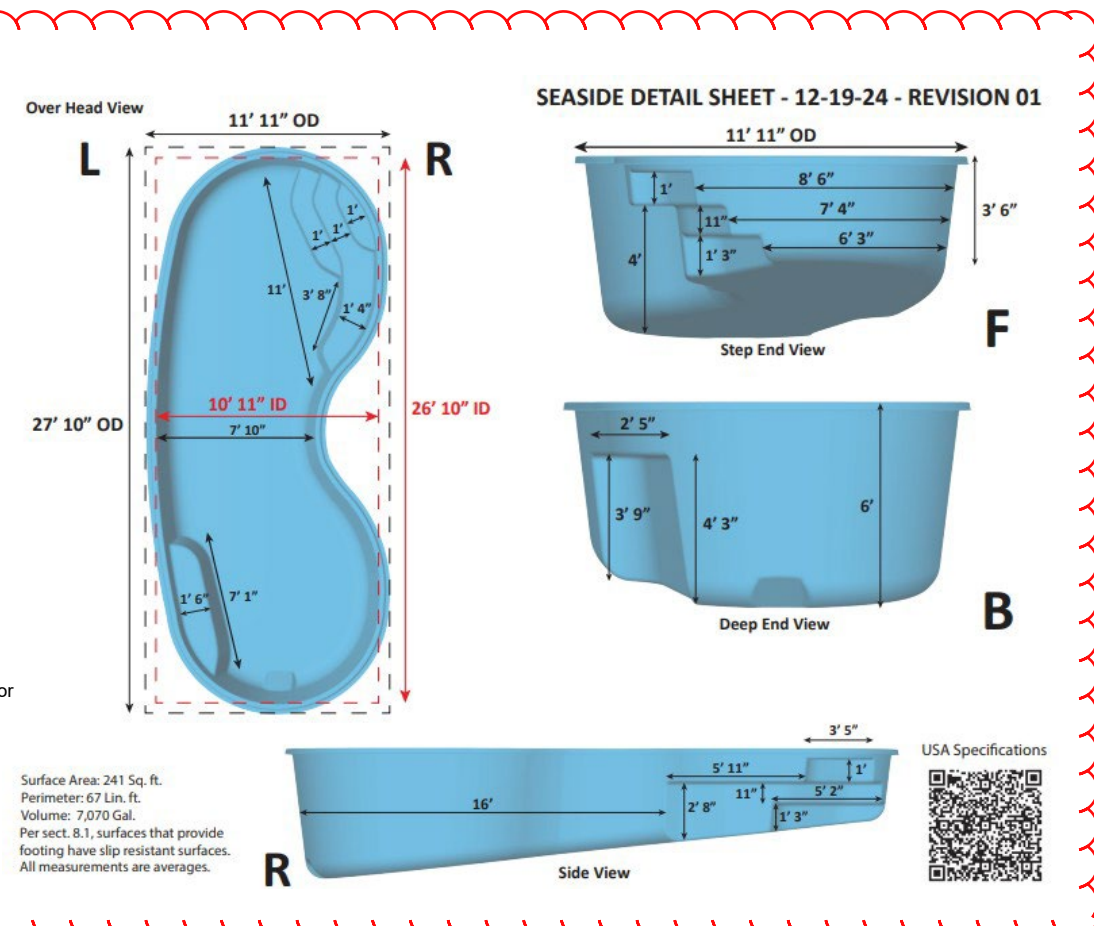

**GENERAL CONSTRUCTION NOTES: Cont-**

10. –Pool installation shall be by a qualified and licensed (approved by local building department and San Juan pools) pool contractor. The installation shall conform to all state and local building codes, as well as tenants of any association with Jurisdiction.
11. –Water supply and disposal shall be so arranged that there is no cross connection with domestic service.
12. –Main drain cover to be certified as compliant with ANSI/ASME A112.19.8M or a grate with a minimum open area of 144 sq. in. or as to local codes, securely fastened in place.
13. –All electric shall conform to N.E.C. No overhead wires shall pass within 10 feet of pool.
14. –Concrete shall be min. 2500 psi at 28 days. Deck Slab to have 6x6, #10/10 wwm or equal suspended in conc. Fibermesh conc. may be used in lieu of 6x6 10x10 wwm as allowed by local codes.
15. –Pool bottom to be placed in 4" min. sand or 3/8" max dia stone.
16. –Hydrostatic pressures: design assumes pool is full at all times, with any required hold downs and reinforcing by others.
17. –Hydrostatic relief valve not credited for more than 2 feet of the difference of head between pool bottom and floor criteria level, use where code requires.
18. – Pool shall bear on undisturbed soil, free of peat, muck or other deleterious material of any significant amount.

PLAN EXPIRES 1 YEAR FROM THE SIGNATURE DATE OR THE EFFECTIVE DATE OF A MAJOR FLORIDA BUILDING CODE CHANGE WHICHEVER IS SOONER	My Favorite Pool Builder, Inc. 4887 N US Hwy 441 Lake City, FL. 32055 (386) 269-3304 OFF (386) 965-0066 Cell CPC1459058
2/27/2026	Swimming Pool Specification For: Reginald or Wendy Davis 242 SW Godbold Ave. Lake City, FL 32024 757-752-1401
	Scale: None Rev Page 3 of 7

Contractor; My Favorite Pool Builder, Inc. CPC1459058 Steve Cronin  
386-965-0066 steve@mfpblc.com

Pump Pentair Inteliflow 3  
Filter Pentair SD80 Sand Filter  
Pump and filter information located on page 2 of 7

**Swimming Pool Energy Efficiency Compliance Information**  
**NOTE: These Requirements Apply ONLT to Filtration Pumps**  
**ANSI/APSP/ICC-15 2011**

**Flow Calculations**

Pool water volume 7,070 ÷ 360 = 20 GPM - this is the calculated flow rate

NOTE: for pools under 13,000 gals. The calculated flow rate or 36 gpm whichever is greater = filtration flow rate

Is there an Auxiliary load on the filter?  Yes  No  
If so what is the calculated auxiliary flow rate \_\_\_\_\_ gpm

Flow rate (low speed) 35 gpm @ 2000 rpm.  
Minimum suction side pipe size @ 6 fps 1.5 in. Minimum suction side branch pipe size @ 6 fps 1.5 in.  
Minimum return side pipe size @ 8 fps 1.5 in. Minimum return side branch pipe size @ 8 fps 1.5 in.

**Determine Filter Size:**

Filter Factors (GPM/SF): \_\_\_\_\_ Cartridge (0.375) \_\_\_\_\_ DE (2.0) \_\_\_\_\_ Sand (15)  
Filter Size: 75 (Flow rate) 15 (Filter Fact) 5 (Filter Size)

**Pump Controls**

Filtration pump has no auxiliary load - standard time clock   
Filtration pump with auxiliary load - Control model for low speed default within 24 hr.  
Filtration pump with auxiliary load - Control model for low speed default within 24 hr. Programmable controller

**Pump Model** Pentair 3hp Inteliflow VSF  
**Heater Model** Master Temp 125k Master Temp 125k  
Gas Heater efficiency rating 89  
Heat Pump efficiency C.O.P. 2 Eco Stealth Heat Pump

**ANSI 5 & ANSI 7 Compliance Work Sheet**

**Determine Simplified TDH:**

1. Distance from pool to pump in feet: 100 Pipe size suction 2in Pipe Size Return 2in  
2. Friction loss (in suction pipe) in (6) 2 Inch pipe per 1 ft. @ 0.06 GPM = 0.12 (from pipe flow/friction loss chart)  
3. Friction loss (in return pipe) in (8) 2 Inch pipe per 1 ft. @ 0.10 GPM = 0.2 (from pipe flow/friction loss chart)

Date	<u>2/27/2026</u>	Suction	<u>12</u>
Contractor Signature	<u>Reginald or Wendy Davis</u>	Return	<u>20</u>
CPC1459058	Owner Name	Filter	<u>1.8</u>
Contractors Cert #	<u>242 SW Godbold Ave</u>	Heater	<u>0</u>
386-965-0066	Lake City, FL 32024	TDH in Piping	<u>32</u>
Contractors Tele#	Address	Filter/Heater loss in TDH	<u>1.8</u>
	Scale None	All other Losses Fittings and Values	<u>8</u>
		Total Dynamic Head (TDH)	<u>41.8</u>

Pipe Size	Velocity - Feet Per Second					
	6 FPS		8 FPS		10 FPS	
1.5"	37 gpm	0.08'	50 gpm	.14'	62 gpm	.21'
2"	62 gpm	0.06'	82 gpm	.10"	103 gpm	.16'
2.5"	88 gpm	0.05'	117 gpm	.08'	148 gpm	.13'
3"	136 gpm	0.04'	181 gpm	.07'	227 gpm	.10'
4"	234 gpm	0.03'	313 gpm	.05'	392 gpm	.07'
6"	534 gpm	0.02'	712 gpm	.03'		

**SECTION IV. TECHNICAL DATA (cont'd)**  
B. FNS<sup>®</sup> PLUS FLOW RATES

Pump Performance Curves (3HP IntelliFlo Pumps)

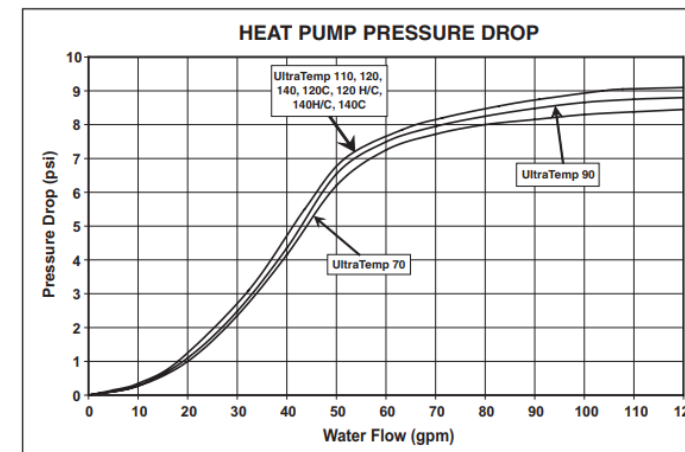
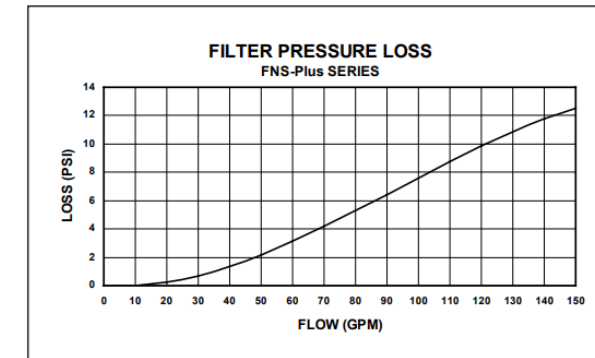
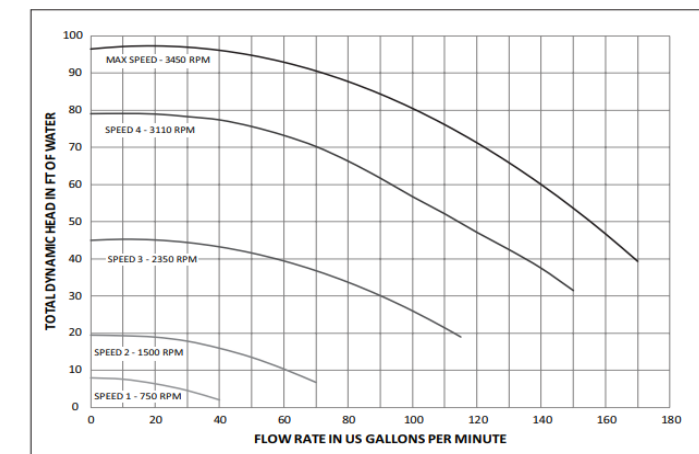

**.Safety - Aluminum fence**  
No Pool lighting is 12 volt LED  
No Footer  
3IN Deck drain across pool deck  
Bonding per code page 2 of 7  
Pool is 233 SqFt  
Pool Deck is 403 SQ Ft  
Pool depth 3' 6" to 6' 0" top of rim

PLAN EXPIRES 1 YEAR FROM THE SIGNATURE DATE OR THE EFFECTIVE DATE OF A MAJOR FLORIDA BUILDING CODE CHANGE WHICHEVER IS SOONER

2/27/2026

My Favorite Pool Builder, Inc.  
4887 N US Hwy 441  
Lake City, FL. 32055  
(386) 269-3304 OFF  
(386) 965-0066 Cell  
CPC1459058

Swimming Pool Specification For:  
Reginald or Wendy Davis  
242 SW Godbold Ave. Lake City, FL 32024  
757-752-1401

Scale: None Rev  
Page 4 of 7

Contractor; My Favorite Pool Builder, Inc. CPC1459058 Steve Cronin  
386-965-0066 steve@mfpblc.com

Pump Pentair Inteliflow 3  
Filter Pentair SD80 Sand Filter  
Pump and filter information located on page 2 of 7

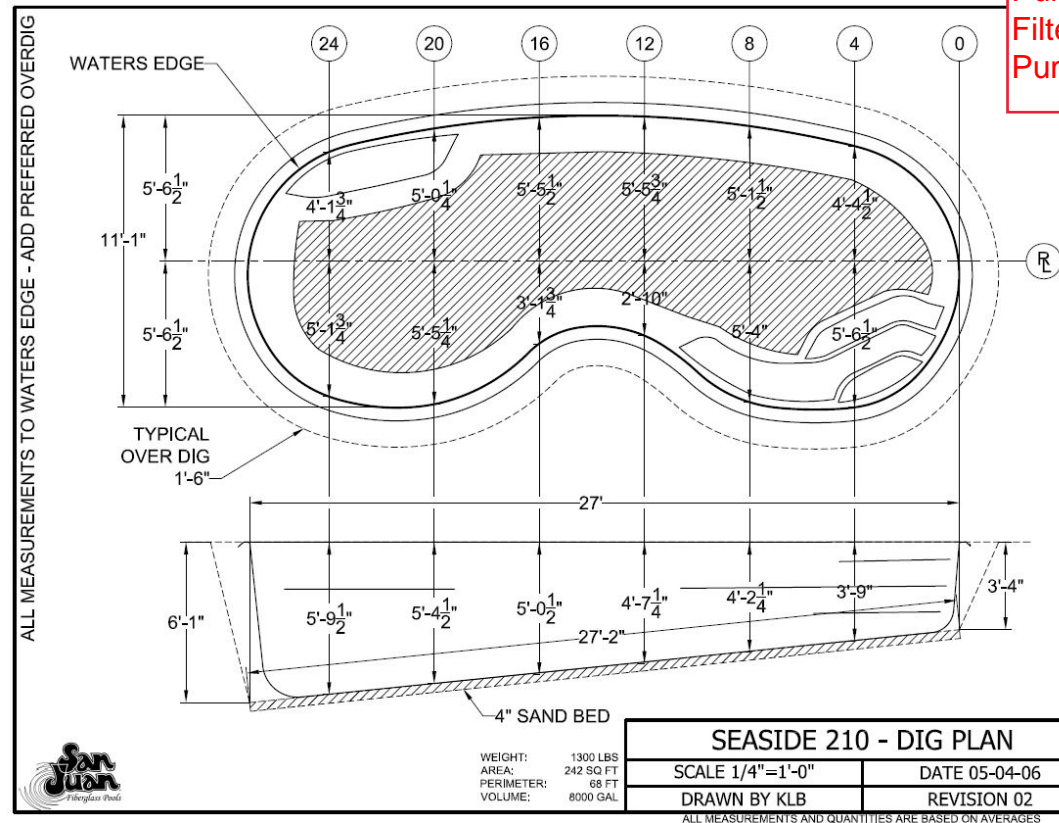

. Reginald or Wendy Davis  
. 242 SW Godbold Ave  
. Lake City, Fl. 32024  
. Par ID #11-4S-15-00336-019  
Contractor; My Favorite Pool Builder, Inc. CPC1459058 Steve Cronin  
386-965-0066 steve@mfpblc.com

Distance from Pool water line to property line.  
77 FT to North  
115 FT to South  
472 FT to East  
414 FT to West  
6' ≥ Pool to house  
< Well Water < power under ground  
Septic tank Right side of house and private well water  
Power Company FPL EI L side of house. Power to house is run underground and is more than 45.5' < away from pools waters edge

NO Glass with 60IN Of pools water

Pool deck water will Drain away from pool onto ground. 3" deck drain. No change to current water drainage direction

.Safety - Aluminum fence  
No Pool lighting is 12 volt LED  
No Footer  
3IN Deck drain across pool deck  
Bonding per code page 2 of 7  
Pool is 233 SqFt  
Pool Deck is 403 SQ Ft  
Pool depth 3' 6" to 6' 0" top of rim

PLAN EXPIRES 1 YEAR FROM THE SIGNATURE DATE OR THE EFFECTIVE DATE OF A MAJOR FLORIDA BUILDING CODE CHANGE WHICHEVER IS SOONER

2/27/2026

My Favorite Pool Builder, Inc.  
4887 N US Hwy 441  
Lake City, FL. 32055  
(386) 269-3304 OFF  
(386) 965-0066 Cell  
CPC1459058

Swimming Pool Specification For:  
Reginald or Wendy Davis  
242 SW Godbold Ave. Lake City, FL 32024  
757-752-1401

Scale: None Rev  
Page 5 of 7

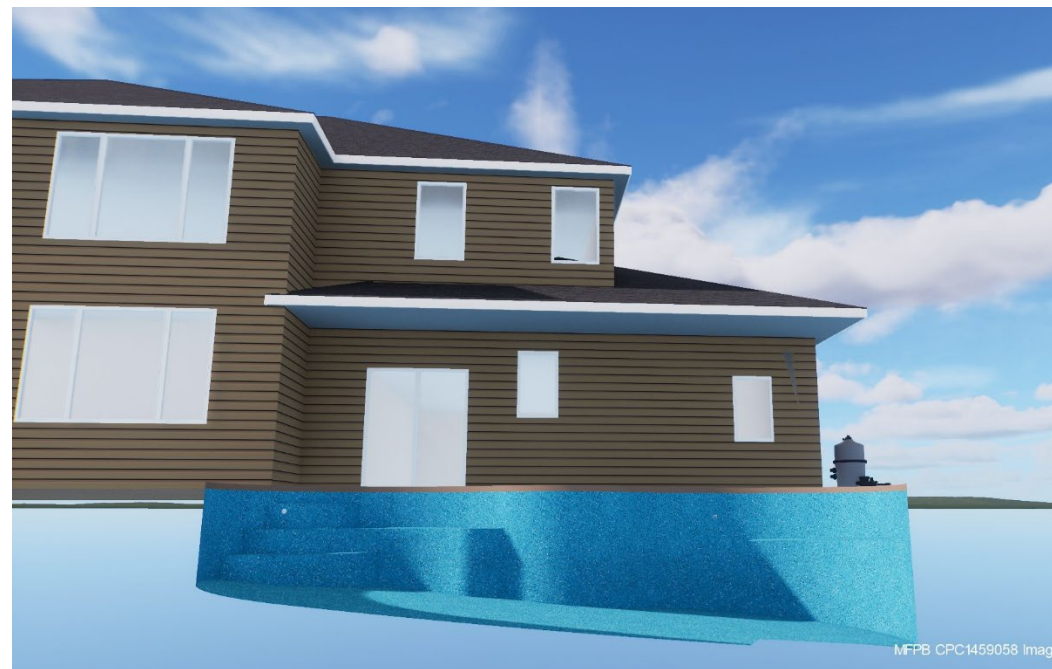

Plumbing and Light Details  
 All Pipe is Sch 40  
 - - - - - 2IN Skimmer - - - - -  
 ..... 2 IN Returns .....  
 — 12 Volt Color Led Light —  
 ..... 2IN Spa Return .....  
 - - - - - 2IN Spa Main Drain - - - - -

Contractor; My Favorite Pool Builder, Inc. CPC1459058 Steve Cronin  
 386-965-0066 steve@mfpblc.com  
 Pump Pentair Inteliflow 3  
 Filter Pentair SD80 Sand Filter  
 Pump and filter information located on page 2 of 7

. Reginald or Wendy Davis  
 . 242 SW Godbold Ave  
 . Lake City, Fl. 32024  
 .Par ID #11-4S-15-00336-019  
 Contractor; My Favorite Pool Builder, Inc. CPC1459058 Steve Cronin  
 386-965-0066 steve@mfpblc.com

Distance from Pool water line to property line.  
 77 FT to North  
 115 FT to South  
 472 FT to East  
 414 FT to West  
 6' ≥ Pool to house  
 < Well Water < power under ground  
 Septic tank Right side of house and private well water  
 Power Company FPL El L side of house. Power to house is run underground and is more than 45.5' < away from pools waters edge  
 NO Glass with 60IN Of pools water  
 Pool deck water will Drain away from pool onto ground. 3" deck drain. No change to current water drainage direction

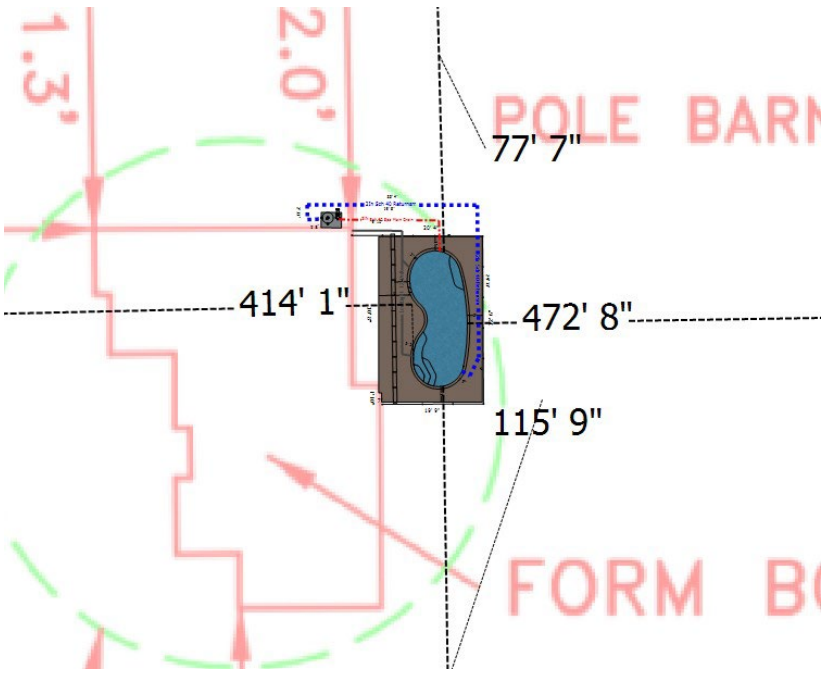
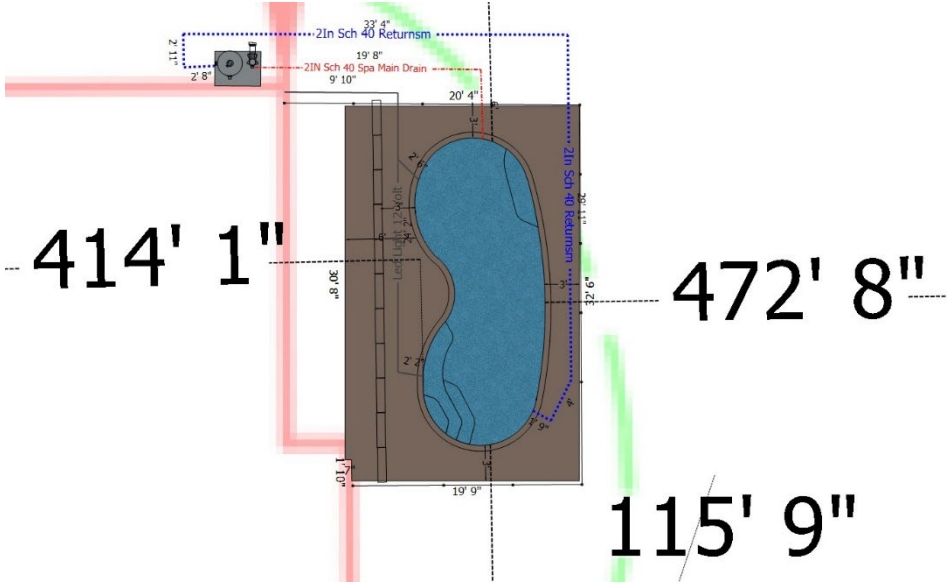

.Safety - Aluminum fence  
 No Pool lighting is 12 volt LED  
 No Footer  
 3IN Deck drain across pool deck  
 Bonding per code page 2 of 7  
 Pool is 233 SqFt  
 Pool Deck is 403 SQ Ft  
 Pool depth 3' 6" to 6' 0" top of rim

PLAN EXPIRES 1 YEAR FROM THE SIGNATURE DATE OR THE EFFECTIVE DATE OF A MAJOR FLORIDA BUILDING CODE CHANGE WHICHEVER IS SOONER

2/27/2026

My Favorite Pool Builder, Inc.  
 4887 N US Hwy 441  
 Lake City, FL. 32055  
 (386) 269-3304 OFF  
 (386) 965-0066 Cell  
 CPC1459058

Swimming Pool Specification For:  
 Reginald or Wendy Davis  
 242 SW Godbold Ave. Lake City, FL 32024  
 757-752-1401

Scale: None Rev  
 Page 6 of 7

Contractor; My Favorite Pool Builder, Inc. CPC1459058 Steve Cronin  
386-965-0066 steve@mfpblc.com

Pump Pentair Inteliflow 3  
Filter Pentair SD80 Sand Filter  
Pump and filter information located on page 2 of 7

Concrete	1 if you want 0 if you don't need		
Pool Perimeter			
66	27	1	2.44
Deck area 4 in Dec Yards			
403	80	1	5.04
Deck Perimeter			
69	80		8x8 footer
69	25		12x12 footer
Total Yards			7.5

. Reginald or Wendy Davis  
. 242 SW Godbold Ave  
. Lake City, Fl. 32024  
. Par ID #11-4S-15-00336-019  
Contractor; My Favorite Pool Builder, Inc. CPC1459058 Steve Cronin  
386-965-0066 steve@mfpblc.com

Distance from Pool water line to property line.  
77 FT to North  
115 FT to South  
472 FT to East  
414 FT to West  
6'± Pool to house  
< Well Water< power under ground  
Septic tank Right side of house and private well water  
Power Company FPL EI L side of house. Power to house is run underground and is more than 45.5'< away from pools waters edge

NO Glass with 60IN Of pools water

Pool deck water will Drain away from pool onto ground. 3" deck drain. No change to current water drainage direction

.Safety - Aluminum fence  
No Pool lighting is 12 volt LED  
No Footer  
3IN Deck drain across pool deck  
Bonding per code page 2 of 7  
Pool is 233 SqFt  
Pool Deck is 403 SQ Ft  
Pool depth 3' 6" to 6' 0" top of rim

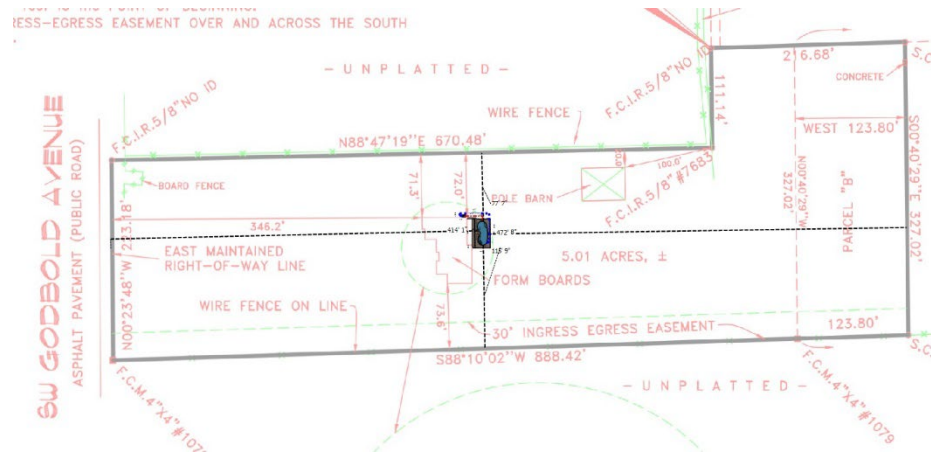

PLAN EXPIRES 1 YEAR FROM THE SIGNATURE DATE OR THE EFFECTIVE DATE OF A MAJOR FLORIDA BUILDING CODE CHANGE WHICHEVER IS SOONER

2/27/2026



My Favorite Pool Builder, Inc.  
4887 N US Hwy 441  
Lake City, FL. 32055  
(386) 269-3304 OFF  
(386) 965-0066 Cell  
CPC1459058

Swimming Pool Specification For:  
Reginald or Wendy Davis  
242 SW Godbold Ave. Lake City, FL  
32024  
757-752-1401

Scale: None Rev  
Page 7 of 7