



**STRUCTURAL DESIGN**  
**ENCLOSED BUILDING**  
**EXPOSURE B**

**MAXIMUM 30'-0" WIDE X 20'-0" EAVE HEIGHT- BOX EAVE  
FRAME AND BOW FRAME**

**29 July 2021**

**Revision 6**

**M&A Project No. 16022S/17300S/20352S**

**Prepared for:**

**Tubular Building Systems, LLC  
631 SE Industrial Circle  
Lake City, Florida 32025**

**Prepared by:**

**Moore and Associates Engineering and Consulting, Inc.  
1009 East Avenue  
North Augusta, SC 29841**

**401 S. Main Street, Suite 200  
Mount Airy, NC 27030**



This item has been electronically signed and sealed by Wayne S. Moore, PE. using a Digital Signature and date.

Printed copies of this document are not considered signed and sealed and the signature must be verified on any electronic copies.



This item has been electronically signed and sealed by Wayne S. Moore, PE. using a Digital Signature and date.

Printed copies of this document are not considered signed and sealed and the signature must be verified on any electronic copies.

<b>MOORE AND ASSOCIATES ENGINEERING AND CONSULTING, INC.</b>	DRAWN BY: JG		<b>TUBULAR BUILDING SYSTEMS 30'-0"x20'-0" ENCLOSED BUILDING EXP. B PE SEAL COVER SHEET</b>	
	CHECKED BY: PDH			
THIS DOCUMENT IS THE PROPERTY OF MOORE AND ASSOCIATES ENGINEERING AND CONSULTING. THE UNAUTHORIZED REPRODUCTION, COPYING, OR OTHERWISE USE OF THIS DOCUMENT IS STRICTLY PROHIBITED AND ANY INFRINGEMENT THEREUPON MAY BE SUBJECT TO LEGAL ACTION.	PROJECT MGR: WSM	DATE: 7-29-21	SCALE: NTS	JOB NO: 16022S/ 17300S/20352S
	CLIENT: TBS	SHT. 1	DWG. NO: SK-3	REV: 6

# DRAWING INDEX

SHEET 1	PE SEAL COVER SHEET
SHEET 2	DRAWING INDEX
SHEET 3	INSTALLATION NOTES AND SPECIFICATIONS
SHEET 4	TYPICAL SIDE AND END ELEVATIONS
SHEET 5	TYPICAL RAFTER COLUMN END AND SIDE FRAMING SECTIONS (BOX EAVE RAFTER)
SHEET 5A	TYPICAL RAFTER COLUMN END AND SIDE FRAMING SECTIONS (BOX EAVE RAFTER)
SHEET 5B	TYPICAL RAFTER COLUMN END AND SIDE FRAMING SECTIONS (BOX EAVE RAFTER)
SHEET 6	TYPICAL RAFTER COLUMN CONNECTION DETAILS (LACED COLUMN)
SHEET 6A	TYPICAL RAFTER COLUMN CONNECTION DETAILS (DOUBLE COLUMN)
SHEET 6B	TYPICAL RAFTER COLUMN CONNECTION DETAILS (SINGLE COLUMN)
SHEET 7	TYPICAL RAFTER COLUMN END AND SIDE FRAMING SECTIONS (BOW RAFTER)
SHEET 7A	TYPICAL RAFTER COLUMN END AND SIDE FRAMING SECTIONS (BOW RAFTER)
SHEET 8	TYPICAL RAFTER COLUMN CONNECTION DETAILS (DOUBLE COLUMN)
SHEET 8A	TYPICAL RAFTER COLUMN CONNECTION DETAILS (SINGLE COLUMN)
SHEET 9	BASE RAIL ANCHORAGE OPTIONS FOR LOW AND HIGH WIND SPEED
SHEET 9A	OPTIONAL FOUNDATION ANCHORAGE FOR LOW AND HIGH WIND SPEED
SHEET 9B	BASE RAIL ANCHORAGE OPTION
SHEET 9C	BASE RAIL ANCHORAGE OPTIONS
SHEET 10	BOX EAVE RAFTER END WALL AND SIDE WALL OPENINGS
SHEET 11	BOW RAFTER END WALL AND SIDE WALL OPENINGS
SHEET 12	CONNECTION DETAILS
SHEET 13	CONNECTION DETAILS
SHEET 14	BOX EAVE RAFTER LEAN-TO OPTIONS
SHEET 14A	BOX EAVE RAFTER LEAN-TO OPTIONS
SHEET 15	BOW RAFTER LEAN-TO OPTIONS
SHEET 16	VERTICAL ROOF/SIDING OPTION
SHEET 17	OPTIONAL DOOR HEADER
SHEET 18	FLOOD VENT DETAIL
SHEET 19	STAND-ALONE STEM WALL DETAIL
SHEET 20	VERTICAL SLIDING WINDOW DETAIL
SHEET 21	STRIP FOOTING OPTION



This item has been electronically signed and sealed by Wayne S. Moore, PE. using a Digital Signature and date.

Printed copies of this document are not considered signed and sealed and the signature must be verified on any electronic copies.

**MOORE AND ASSOCIATES  
ENGINEERING AND CONSULTING, INC.**

**DRAWN BY: JG**

**CHECKED BY: PDH**

**PROJECT MGR: WSM**

**CLIENT: TBS**

**TUBULAR BUILDING SYSTEMS  
631 SE INDUSTRIAL CIRCLE  
LAKE CITY, FLORIDA 32025  
30'-0"x20'-0" ENCLOSED BUILDING EXP. B**

**DATE: 7-29-21**

**SCALE: NTS**

**JOB NO: 16022S/  
17300S/20352S**

**SHT: 2**

**DWG. NO: SK-3**

**REV: 6**

THIS DOCUMENT IS THE PROPERTY OF MOORE AND ASSOCIATES ENGINEERING AND CONSULTING. THE UNAUTHORIZED REPRODUCTION, COPYING, OR OTHERWISE USE OF THIS DOCUMENT IS STRICTLY PROHIBITED AND ANY INFRINGEMENT THEREUPON MAY BE SUBJECT TO LEGAL ACTION.

## INSTALLATION NOTES AND SPECIFICATIONS

- 1 DESIGN IS FOR A MAXIMUM 30'-0" WIDE x 20'-0" EAVE HEIGHT ENCLOSED STRUCTURES
- 2 DESIGN WAS DONE IN ACCORDANCE WITH THE 2020 FLORIDA BUILDING CODE (FBC) 7TH EDITION, 2012 INTERNATIONAL BUILDING CODE (IBC), 2015 IBC, AND 2018 IBC
- 3 DESIGN LOADS ARE AS FOLLOWS:
  - A) DEAD LOAD = 15 PSF
  - B) LIVE LOAD = 12 PSF
  - C) GROUND SNOW LOAD = 10 PSF
- 4 LOW ULTIMATE WIND SPEED 105 TO 140 MPH (NOMINAL WIND SPEED 81 TO 108 MPH): MAXIMUM RAFTER/POST AND END POST SPACING = 5.0 FEET
- 5 HIGH ULTIMATE WIND SPEED 141 TO 170 MPH (NOMINAL WIND SPEED 109 TO 132 MPH): MAXIMUM RAFTER/POST AND END POST SPACING = 4.0 FEET
- 6 END WALL COLUMNS (POSTS) AND SIDE WALL COLUMNS ARE EQUIVALENT IN SIZE AND SPACING (UNLESS NOTED OTHERWISE)
- 7 RISK CATEGORY I
- 8 WIND EXPOSURE CATEGORY B
- 9 SPECIFICATIONS APPLICABLE TO 29 GAUGE METAL PANELS FASTENED DIRECTLY TO 2 1/2" x 2 1/2" - 14 GAUGE TUBE STEEL (TS) FRAMING MEMBERS FOR VERTICAL PANELS. 29 GAUGE METAL PANELS SHALL BE FASTENED TO 18 GAUGE HAT CHANNELS (UNLESS OTHERWISE NOTED)
- 10 AVERAGE FASTENER SPACING ON-CENTERS ALONG RAFTERS OR PURLINS, AND POSTS INTERIOR = 9" OR END = 6" (MAX)
- 11 FASTENERS CONSIST OF #12-14x3/4" SELF-DRILLING FASTENER (SDF), USE CONTROL SEAL WASHER WITH EXTERIOR FASTENERS SPECIFICATIONS APPLICABLE ONLY FOR MEAN ROOF HEIGHT OF 20 FEET OR LESS, AND ROOF SLOPES OF 14° (3:12 PITCH) OR LESS. SPACING REQUIREMENTS FOR OTHER ROOF HEIGHTS AND/OR SLOPES MAY VARY. ROOF SLOPES LESS THAN 3:12 REQUIRE USE OF JOINT SEALANT
- 12 STANDARD ANCHORS SHALL BE INSTALLED THROUGH BASE RAIL WITHIN 5" OF EACH COLUMN
- 13 STANDARD GROUND ANCHORS (SOIL NAILS) CONSIST OF #4 REBAR W/WELDED NUT x 30" LONG IN SUITABLE SOIL CONDITIONS MAY BE USED FOR LOW (< 138 MPH NOMINAL) WIND SPEEDS ONLY. OPTIONAL ANCHORAGE MAY BE USED IN SUITABLE SOILS AND MUST BE USED IN UNSUITABLE SOILS AS NOTED. COORDINATE WITH LOCAL CODES/ORDINANCES REGARDING MINIMUM LENGTH FOR FROST DEPTH PROTECTION
- 14 WIND FORCES GOVERN OVER SEISMIC FORCES. SEISMIC PARAMETERS ANALYZED ARE:
  - SOIL SITE CLASS = D
  - RISK CATEGORY I
  - R = 325                      I<sub>e</sub> = 10
  - S<sub>DS</sub> = 1522 g              V = 0.5W
  - S<sub>D1</sub> = 0839 g



This item has been electronically signed and sealed by Wayne S. Moore, PE, using a Digital Signature and date.

Printed copies of this document are not considered signed and sealed and the signature must be verified on any electronic copies.

**MOORE AND ASSOCIATES  
ENGINEERING AND CONSULTING, INC.**

**DRAWN BY: JG**

**CHECKED BY: PDH**

**PROJECT MGR: WSM**

**CLIENT: TBS**

**TUBULAR BUILDING SYSTEMS  
631 SE INDUSTRIAL CIRCLE  
LAKE CITY, FLORIDA 32025  
30'-0"x20'-0" ENCLOSED BUILDING EXP. B**

**DATE: 7-29-21**

**SCALE: NTS**

**SHT. 3**

**DWG. NO: SK-3**

**JOB NO: 16022S/  
17300S/20352S**

**REV: 6**

THIS DOCUMENT IS THE PROPERTY OF MOORE AND ASSOCIATES ENGINEERING AND CONSULTING. THE UNAUTHORIZED REPRODUCTION, COPYING, OR OTHERWISE USE OF THIS DOCUMENT IS STRICTLY PROHIBITED AND ANY INFRINGEMENT THEREUPON MAY BE SUBJECT TO LEGAL ACTION.

## BOX EAVE FRAME RAFTER ENCLOSED BUILDING

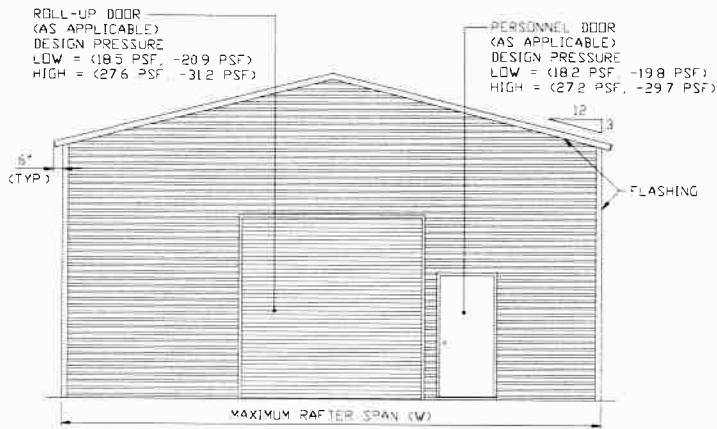

**TYPICAL END ELEVATION**

SCALE: NTS

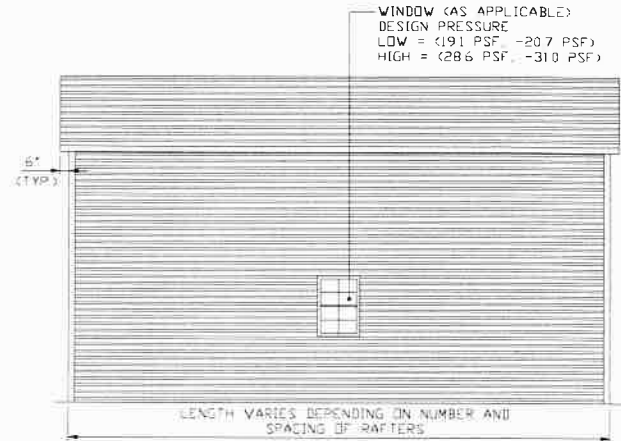

**TYPICAL SIDE ELEVATION**

SCALE: NTS

## BOW FRAME RAFTER ENCLOSED BUILDING

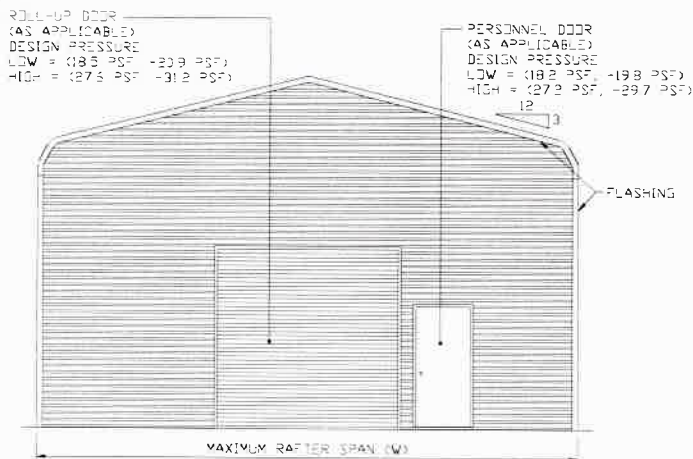

**TYPICAL END ELEVATION**

SCALE: NTS

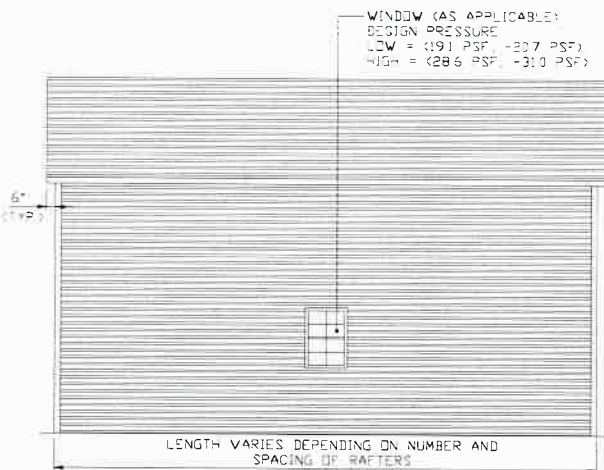

**TYPICAL SIDE ELEVATION**

SCALE: NTS



This item has been electronically signed and sealed by Wayne S. Moore, PE, using a Digital Signature and date.

Printed copies of this document are not considered signed and sealed and the signature must be verified on any electronic copies.

**MOORE AND ASSOCIATES  
ENGINEERING AND CONSULTING, INC.**

DRAWN BY: JG

CHECKED BY: PDH

PROJECT MGR: WSM

CLIENT: TBS

TUBULAR BUILDING SYSTEMS  
631 SE INDUSTRIAL CIRCLE  
LAKE CITY, FLORIDA 32025  
30'-0"X20'-0" ENCLOSED BUILDING EXP. B

DATE: 7-29-21

SHT. 4

SCALE: NTS

DWG. NO: SK-3

JOB NO: 16022S/  
17300S/20352S

REV.: 6

THIS DOCUMENT IS THE PROPERTY OF MOORE AND ASSOCIATES ENGINEERING AND CONSULTING. THE UNAUTHORIZED REPRODUCTION, COPYING, OR OTHERWISE USE OF THIS DOCUMENT IS STRICTLY PROHIBITED AND ANY INFRINGEMENT THEREUPON MAY BE SUBJECT TO LEGAL ACTION.

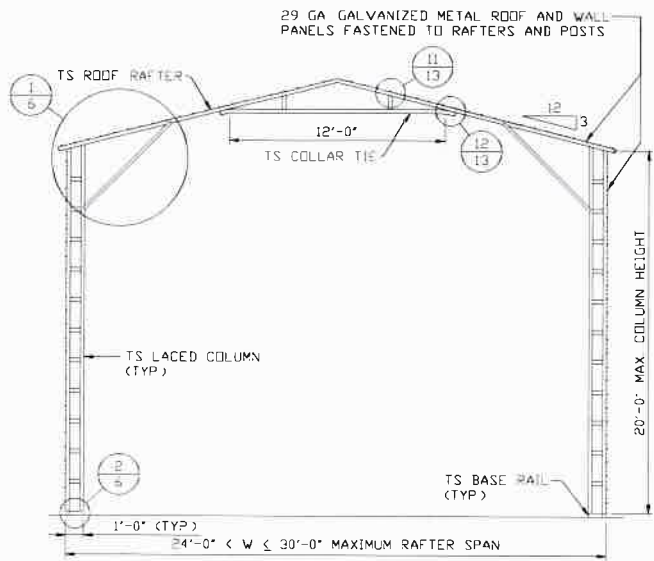

**TYPICAL RAFTER/COLUMN END FRAME SECTION**  
SCALE: NTS

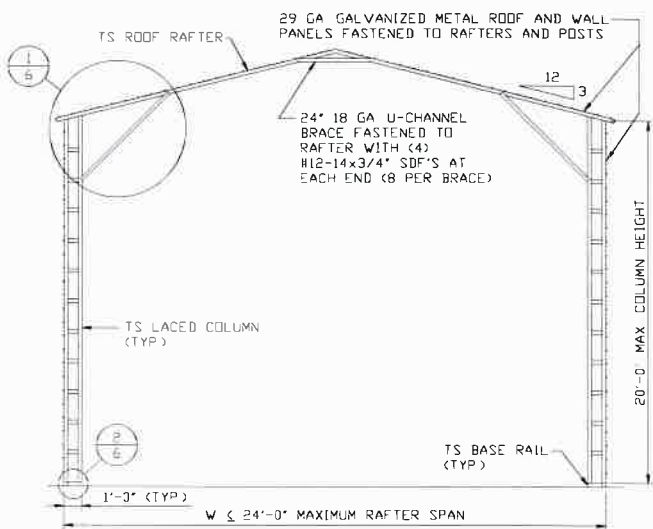

**TYPICAL RAFTER/COLUMN END FRAME SECTION**  
SCALE: NTS

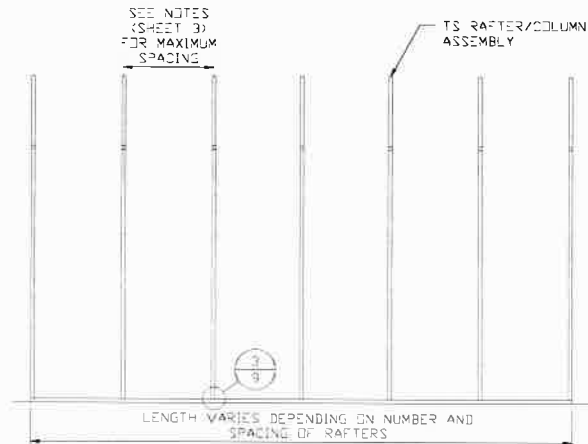

**TYPICAL RAFTER/COLUMN SIDE FRAMING SECTION**  
SCALE: NTS



This item has been electronically signed and sealed by Wayne S. Moore, PE, using a Digital Signature and date.

Printed copies of this document are not considered signed and sealed and the signature must be verified on any electronic copies.

**MOORE AND ASSOCIATES  
ENGINEERING AND CONSULTING, INC.**

DRAWN BY: JG		TUBULAR BUILDING SYSTEMS 631 SE INDUSTRIAL CIRCLE LAKE CITY, FLORIDA 32025 30'-0"x20'-0" ENCLOSED BUILDING EXP. B		
CHECKED BY: PDH				
PROJECT MGR: WSM	DATE: 7-29-21	SCALE: NTS	JOB NO: 16022S/ 17300S/20352S	
CLIENT: TBS	SHT. 5	DWG. NO: SK-3	REV.: 6	

THIS DOCUMENT IS THE PROPERTY OF MOORE AND ASSOCIATES ENGINEERING AND CONSULTING. THE UNAUTHORIZED REPRODUCTION, COPYING, OR OTHERWISE USE OF THIS DOCUMENT IS STRICTLY PROHIBITED AND ANY INFRINGEMENT THEREUPON MAY BE SUBJECT TO LEGAL ACTION.

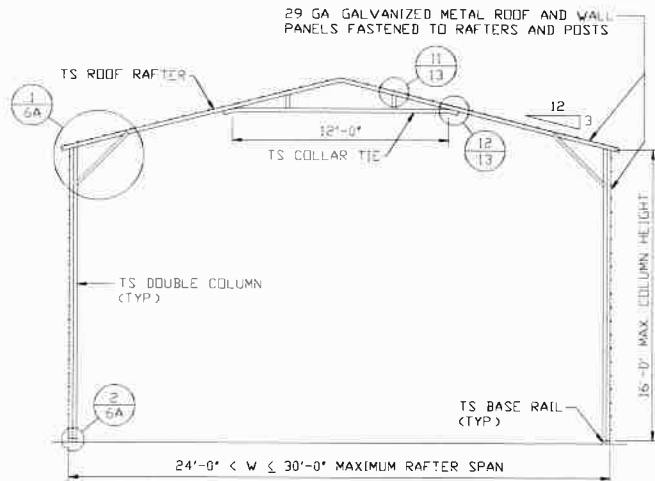

**TYPICAL RAFTER/COLUMN END FRAME SECTION**

SCALE: NTS

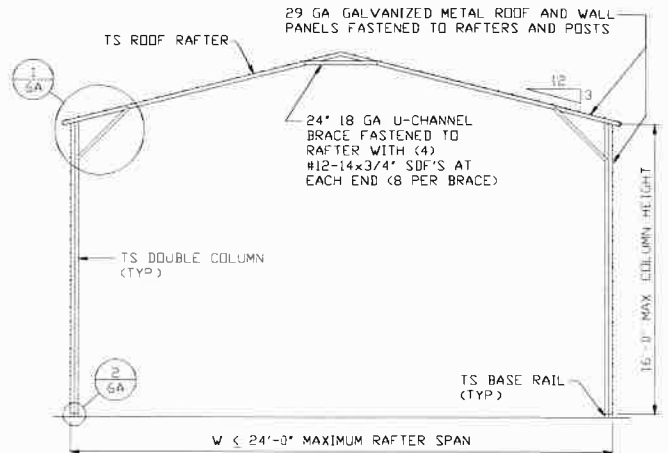

**TYPICAL RAFTER/COLUMN END FRAME SECTION**

SCALE: NTS

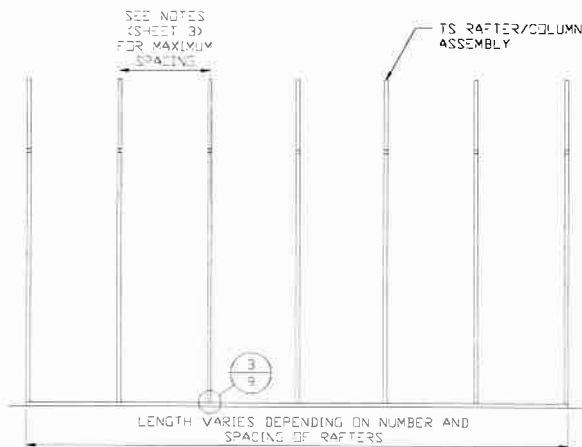

**TYPICAL RAFTER/COLUMN SIDE FRAMING SECTION**

SCALE: NTS



This item has been electronically signed and sealed by Wayne S. Moore, PE. using a Digital Signature and date.

Printed copies of this document are not considered signed and sealed and the signature must be verified on any electronic copies.

**MOORE AND ASSOCIATES  
ENGINEERING AND CONSULTING, INC.**

**DRAWN BY: JG**

**CHECKED BY: PDH**

**TUBULAR BUILDING SYSTEMS  
631 SE INDUSTRIAL CIRCLE  
LAKE CITY, FLORIDA 32025  
30'-0"x20'-0" ENCLOSED BUILDING EXP. B**

THIS DOCUMENT IS THE PROPERTY OF MOORE AND ASSOCIATES ENGINEERING AND CONSULTING. THE UNAUTHORIZED REPRODUCTION, COPYING, OR OTHERWISE USE OF THIS DOCUMENT IS STRICTLY PROHIBITED AND ANY INFRINGEMENT THEREUPON MAY BE SUBJECT TO LEGAL ACTION.

**PROJECT MGR: WSM**

**CLIENT: TBS**

**DATE: 7-29-21**

**SHT. 5A**

**SCALE: NTS**

**DWG. NO: SK-3**

**JOB NO: 16022S/  
17300S/20352S**

**REV: 6**

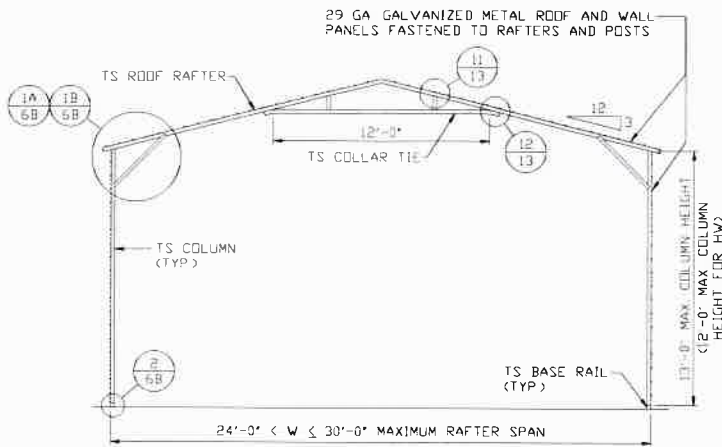

**TYPICAL RAFTER/COLUMN END FRAME SECTION**

SCALE: NTS

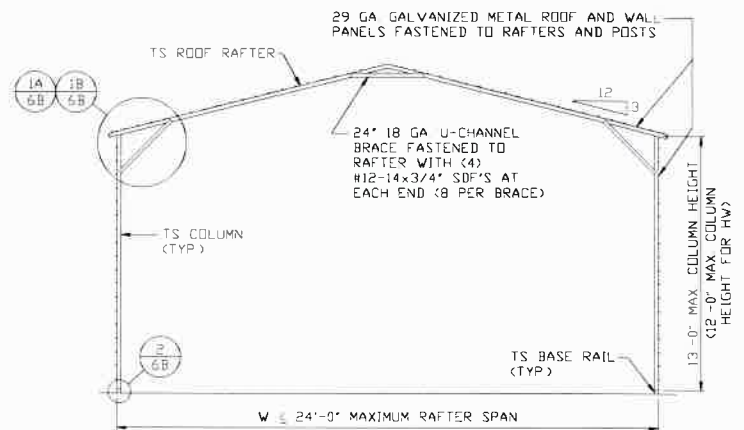

**TYPICAL RAFTER/COLUMN END FRAME SECTION**

SCALE: NTS

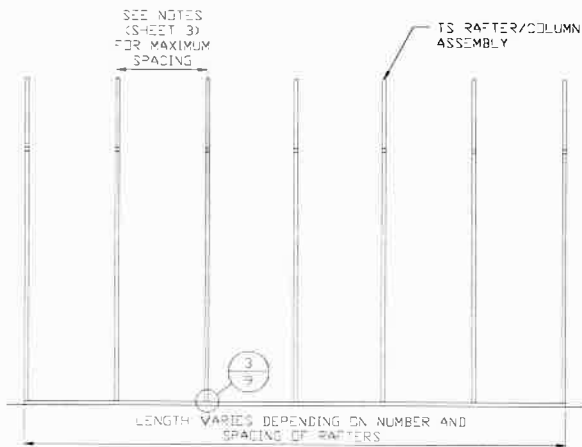

**TYPICAL RAFTER/COLUMN SIDE FRAMING SECTION**

SCALE: NTS



This item has been electronically signed and sealed by Wayne S. Moore, PE, using a Digital Signature and date.

Printed copies of this document are not considered signed and sealed and the signature must be verified on any electronic copies.

**MOORE AND ASSOCIATES  
ENGINEERING AND CONSULTING, INC.**

THIS DOCUMENT IS THE PROPERTY OF MOORE AND ASSOCIATES ENGINEERING AND CONSULTING. THE UNAUTHORIZED REPRODUCTION, COPYING, OR OTHERWISE USE OF THIS DOCUMENT IS STRICTLY PROHIBITED AND ANY INFRINGEMENT THEREUPON MAY BE SUBJECT TO LEGAL ACTION.

DRAWN BY: JG

CHECKED BY: PDH

PROJECT MGR: WSM

CLIENT: TBS

TUBULAR BUILDING SYSTEMS  
631 SE INDUSTRIAL CIRCLE  
LAKE CITY, FLORIDA 32025  
30'-0" x 20'-0" ENCLOSED BUILDING EXP. B

DATE: 7-29-21

SCALE: NTS

JOB NO: 16022S/  
17300S/20352S

SHT. 5B

DWG. NO: SK-3

REV: 6

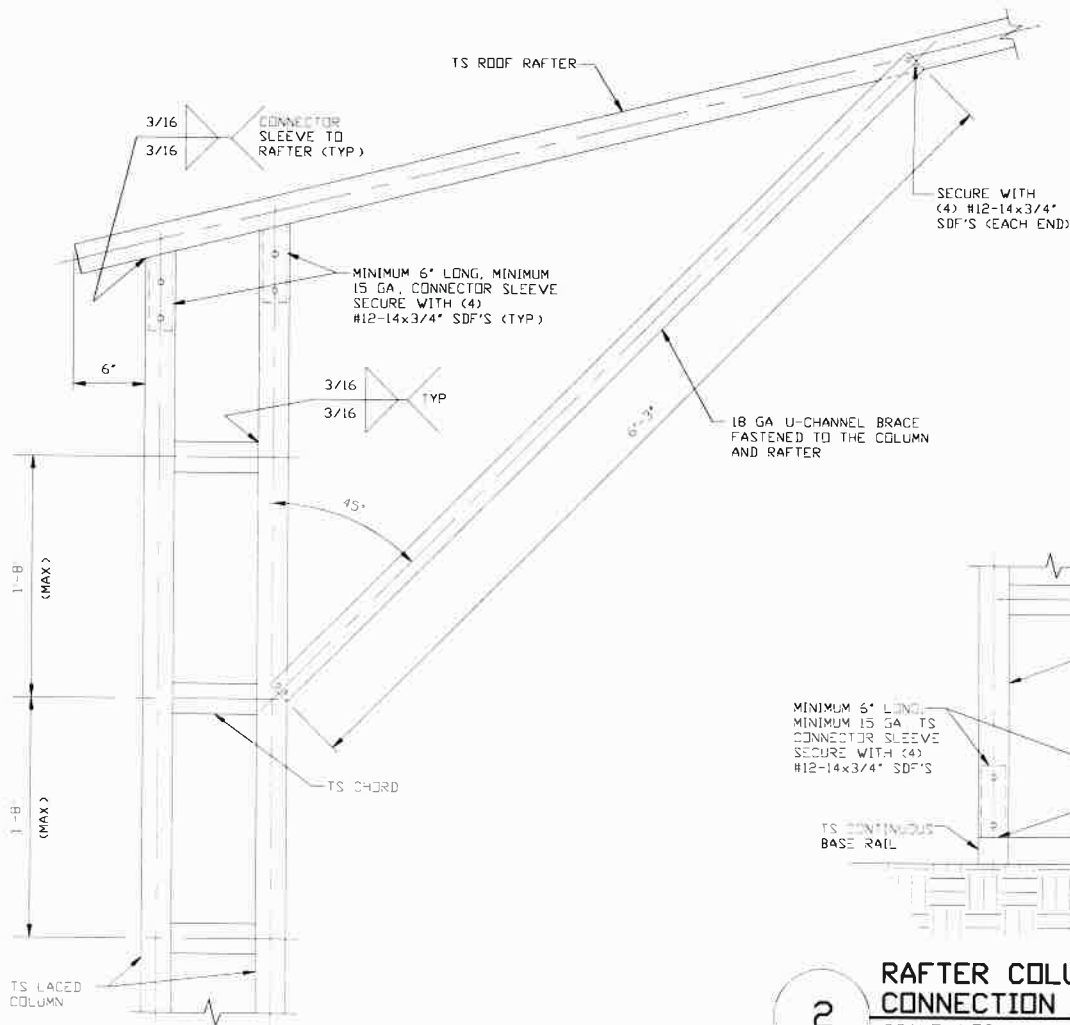

**1** BOX EAVE RAFTER COLUMN CONNECTION DETAIL FOR HEIGHTS 16'-0" < TO ≤ 20'-0" SCALE: NTS

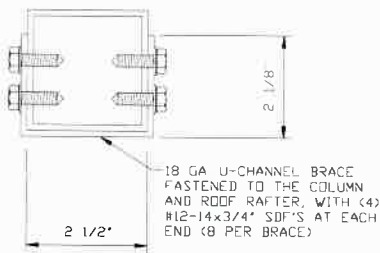

**BRACE SECTION** SCALE: NTS

**2** RAFTER COLUMN/BASE RAIL CONNECTION DETAIL SCALE: NTS

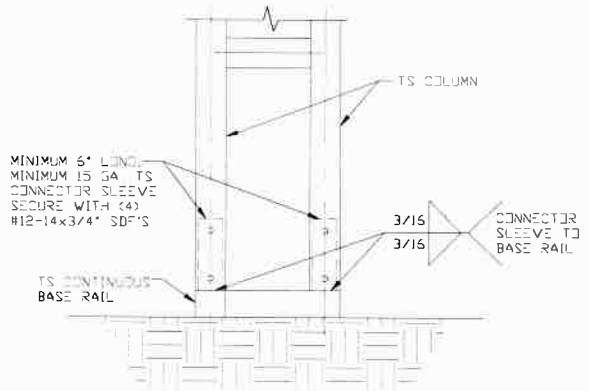

This item has been electronically signed and sealed by Wayne S. Moore, PE. using a Digital Signature and date.

Printed copies of this document are not considered signed and sealed and the signature must be verified on any electronic copies.

**MOORE AND ASSOCIATES ENGINEERING AND CONSULTING, INC.**

DRAWN BY: JG

CHECKED BY: PDH

PROJECT MGR: WSM

CLIENT: TBS

TUBULAR BUILDING SYSTEMS  
631 SE INDUSTRIAL CIRCLE  
LAKE CITY, FLORIDA 32025  
30'-0"x20'-0" ENCLOSED BUILDING EXP. B

DATE: 7-29-21

SCALE: NTS

JOB NO: 16022S/  
17300S/20352S

SHT. 6

DWG. NO: SK-3

REV.: 6

THIS DOCUMENT IS THE PROPERTY OF MOORE AND ASSOCIATES ENGINEERING AND CONSULTING. THE UNAUTHORIZED REPRODUCTION, COPYING, OR OTHERWISE USE OF THIS DOCUMENT IS STRICTLY PROHIBITED AND ANY INFRINGEMENT THEREUPON MAY BE SUBJECT TO LEGAL ACTION.

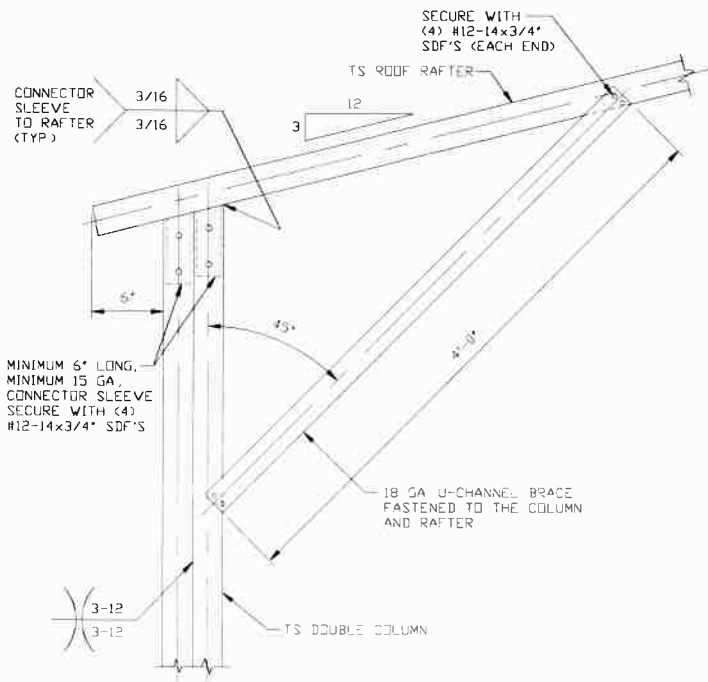

**1** BOX EAVE RAFTER COLUMN CONNECTION DETAIL FOR HEIGHTS 13'-0" < TO ≤ 16'-0"

SCALE: NTS

NOTE: COLUMN HEIGHTS 12'-0" < TO ≤ 15'-0" FOR HIGH WIND

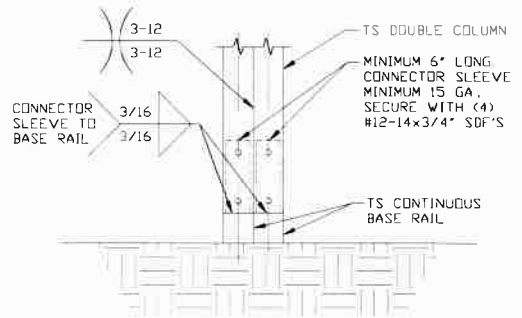

**2** RAFTER COLUMN/BASE RAIL CONNECTION DETAIL

SCALE: NTS

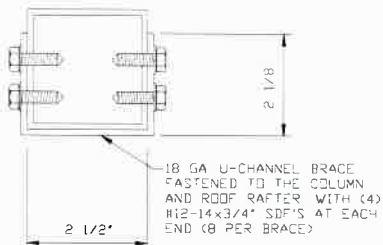

**BRACE SECTION**

SCALE: NTS



This item has been electronically signed and sealed by Wayne S. Moore, PE. using a Digital Signature and date.

Printed copies of this document are not considered signed and sealed and the signature must be verified on any electronic copies.

**MOORE AND ASSOCIATES  
ENGINEERING AND CONSULTING, INC.**

DRAWN BY: JG

CHECKED BY: PDH

PROJECT MGR: WSM

CLIENT: TBS

TUBULAR BUILDING SYSTEMS  
631 SE INDUSTRIAL CIRCLE  
LAKE CITY, FLORIDA 32025  
30'-0"x20'-0" ENCLOSED BUILDING EXP. B

DATE: 7-29-21

SCALE: NTS

DWG. NO: SK-3

JOB NO: 16022S/  
17300S/20352S

REV: 6

THIS DOCUMENT IS THE PROPERTY OF MOORE AND ASSOCIATES ENGINEERING AND CONSULTING. THE UNAUTHORIZED REPRODUCTION, COPYING, OR OTHERWISE USE OF THIS DOCUMENT IS STRICTLY PROHIBITED AND ANY INFRINGEMENT THEREUPON MAY BE SUBJECT TO LEGAL ACTION.

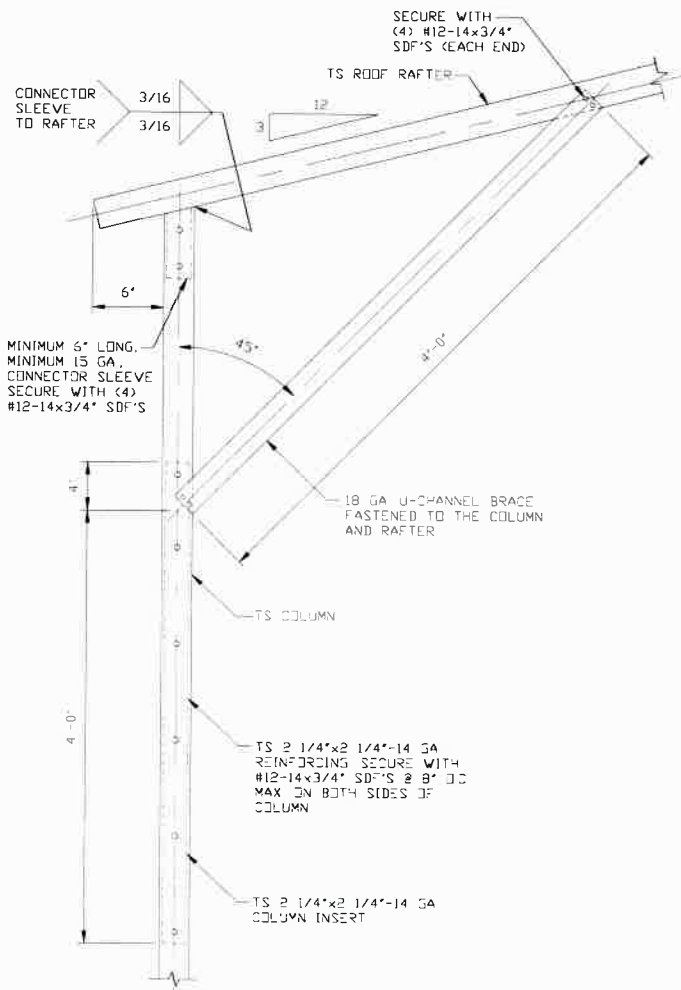

1A

**BOX EAVE RAFTER COLUMN CONNECTION DETAIL FOR HEIGHTS 10'-0" < TO <= 13'-0"**

SCALE: NTS  
NOTE: MAXIMUM COLUMN HEIGHT IS 12'-0" FOR HIGH WIND

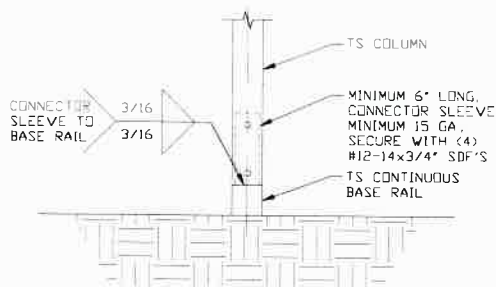

2

**RAFTER COLUMN/BASE RAIL CONNECTION DETAIL**

SCALE: NTS

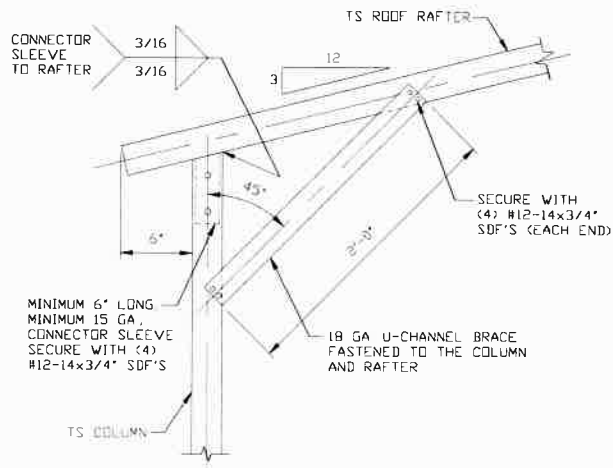

1B

**BOX EAVE RAFTER COLUMN CONNECTION DETAIL FOR HEIGHTS <= 10'-0"**

SCALE: NTS

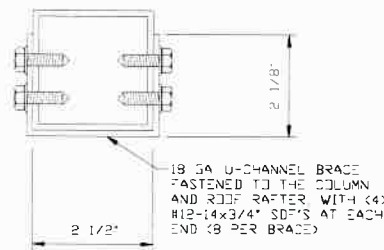

**BRACE SECTION**

SCALE: NTS

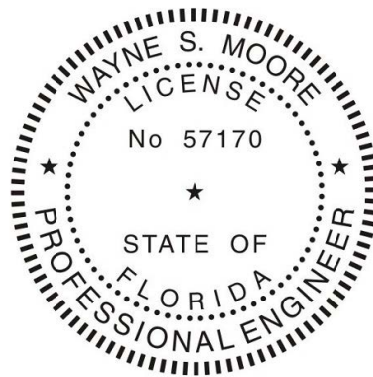

This item has been electronically signed and sealed by Wayne S. Moore, PE, using a Digital Signature and date.

Printed copies of this document are not considered signed and sealed and the signature must be verified on any electronic copies.

**MOORE AND ASSOCIATES ENGINEERING AND CONSULTING, INC.**

DRAWN BY: JG

CHECKED BY: PDH

PROJECT MGR: WSM

CLIENT: TBS

TUBULAR BUILDING SYSTEMS  
631 SE INDUSTRIAL CIRCLE  
LAKE CITY, FLORIDA 32025  
30'-0" x 20'-0" ENCLOSED BUILDING EXP. B

DATE: 7-29-21

SHT. 6B

SCALE: NTS

DWG. NO: SK-3

JOB NO: 16022S/  
17300S/20352S

REV: 6

THIS DOCUMENT IS THE PROPERTY OF MOORE AND ASSOCIATES ENGINEERING AND CONSULTING. THE UNAUTHORIZED REPRODUCTION, COPYING, OR OTHERWISE USE OF THIS DOCUMENT IS STRICTLY PROHIBITED AND ANY INFRINGEMENT THEREUPON MAY BE SUBJECT TO LEGAL ACTION.

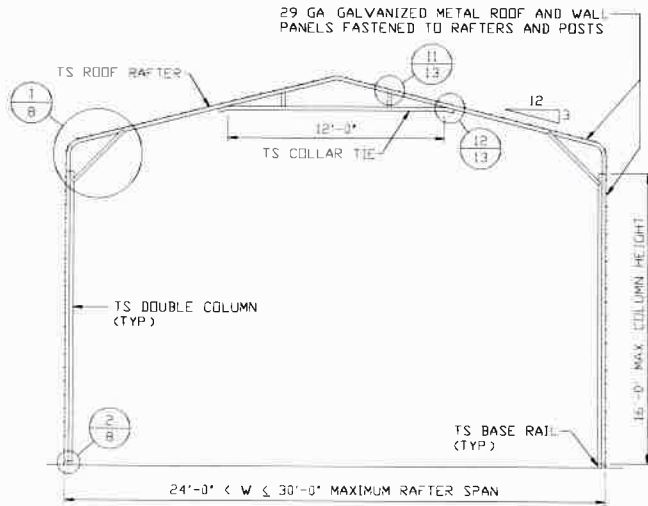

**TYPICAL RAFTER/COLUMN END FRAME SECTION**

SCALE: NTS

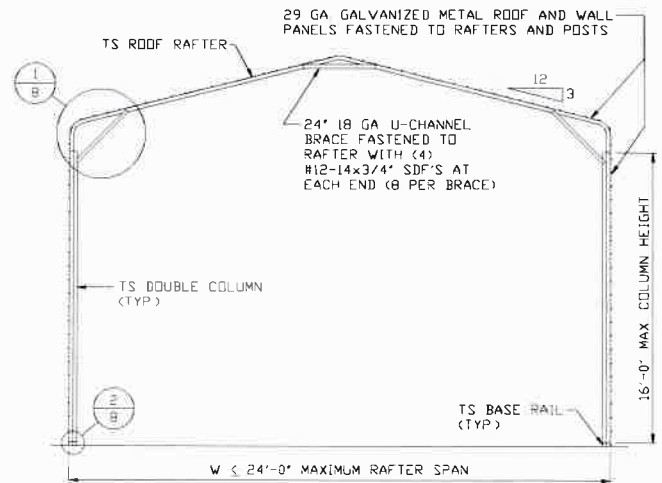

**TYPICAL RAFTER/COLUMN END FRAME SECTION**

SCALE: NTS

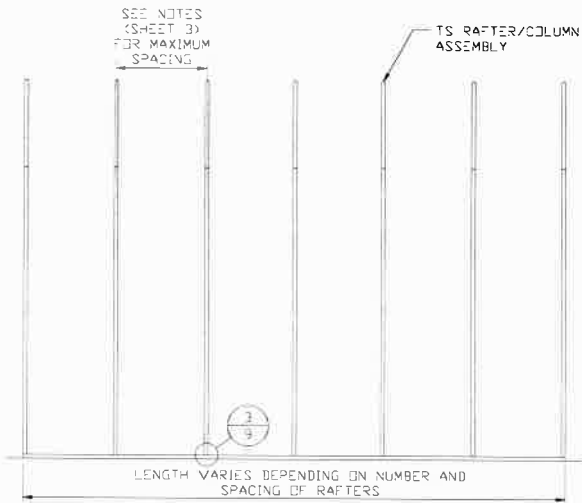

**TYPICAL RAFTER/COLUMN SIDE FRAMING SECTION**

SCALE: NTS

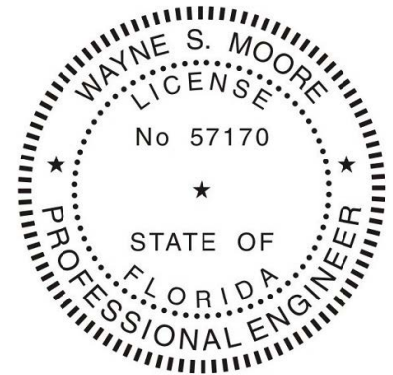

This item has been electronically signed and sealed by Wayne S. Moore, PE. using a Digital Signature and date.

Printed copies of this document are not considered signed and sealed and the signature must be verified on any electronic copies.

**MOORE AND ASSOCIATES  
ENGINEERING AND CONSULTING, INC.**

**DRAWN BY:** JG

**CHECKED BY:** PDH

**PROJECT MGR:** WSM

**CLIENT:** TBS

**TUBULAR BUILDING SYSTEMS  
631 SE INDUSTRIAL CIRCLE  
LAKE CITY, FLORIDA 32025  
30'-0" x 20'-0" ENCLOSED BUILDING EXP. B**

**DATE:** 7-29-21

**SHT.** 7

**SCALE:** NTS

**DWG. NO:** SK-3

**JOB NO:** 16022S/  
17300S/20352S

**REV.:** 6

THIS DOCUMENT IS THE PROPERTY OF MOORE AND ASSOCIATES ENGINEERING AND CONSULTING. THE UNAUTHORIZED REPRODUCTION, COPYING, OR OTHERWISE USE OF THIS DOCUMENT IS STRICTLY PROHIBITED AND ANY INFRINGEMENT THEREUPON MAY BE SUBJECT TO LEGAL ACTION.

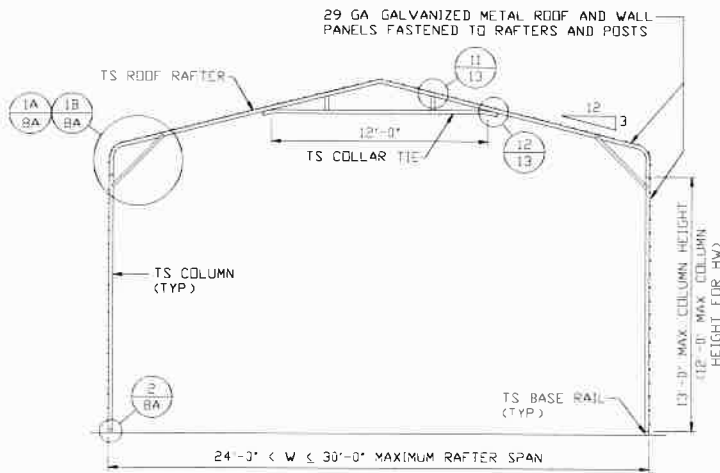

**TYPICAL RAFTER/COLUMN END FRAME SECTION**  
SCALE: NTS

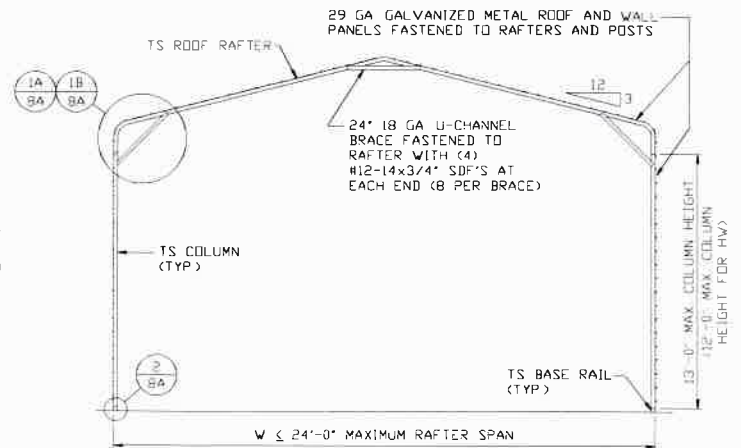

**TYPICAL RAFTER/COLUMN END FRAME SECTION**  
SCALE: NTS

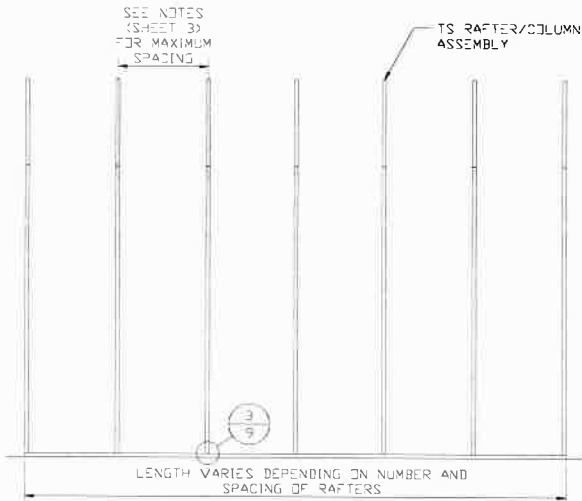

**TYPICAL RAFTER/COLUMN SIDE FRAMING SECTION**  
SCALE: NTS



This item has been electronically signed and sealed by Wayne S. Moore, PE, using a Digital Signature and date.

Printed copies of this document are not considered signed and sealed and the signature must be verified on any electronic copies.

**MOORE AND ASSOCIATES  
ENGINEERING AND CONSULTING, INC.**

DRAWN BY: JG

CHECKED BY: PDH

PROJECT MGR: WSM

CLIENT: TBS

TUBULAR BUILDING SYSTEMS  
631 SE INDUSTRIAL CIRCLE  
LAKE CITY, FLORIDA 32025  
30'-0" x 20'-0" ENCLOSED BUILDING EXP. B

DATE: 7-29-21

SCALE: NTS

JOB NO: 16022S/  
17300S/20352S

SHT. 7A

DWG. NO: SK-3

REV: 6

THIS DOCUMENT IS THE PROPERTY OF MOORE AND ASSOCIATES ENGINEERING AND CONSULTING. THE UNAUTHORIZED REPRODUCTION, COPYING, OR OTHERWISE USE OF THIS DOCUMENT IS STRICTLY PROHIBITED AND ANY INFRINGEMENT THEREUPON MAY BE SUBJECT TO LEGAL ACTION.

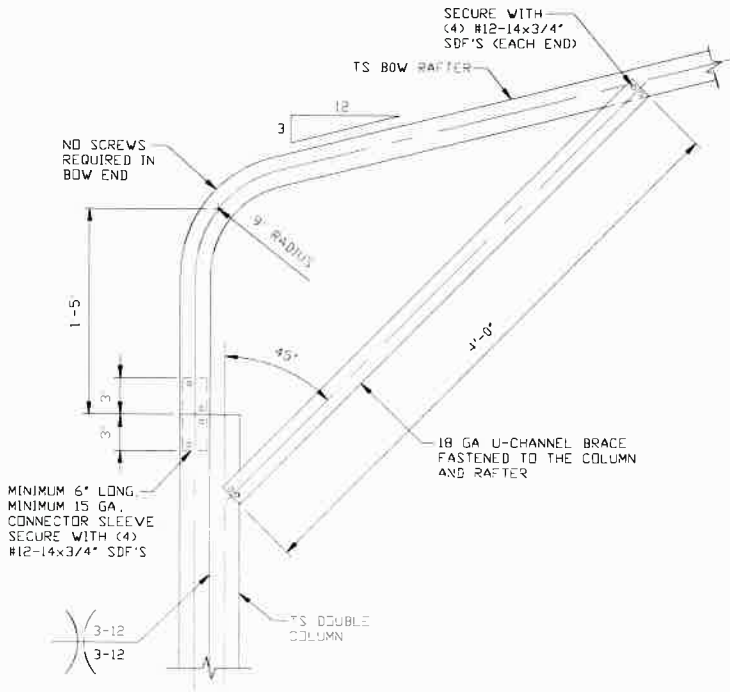

**1** BOX EAVE RAFTER COLUMN CONNECTION DETAIL FOR HEIGHTS 13'-0" < TO ≤ 16'-0"

SCALE: NTS  
NOTE: COLUMN HEIGHTS 12'-0" < TO ≤ 15'-0" FOR HIGH WIND

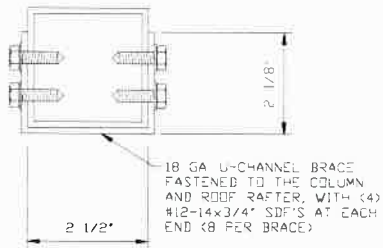

BRACE SECTION  
SCALE: NTS

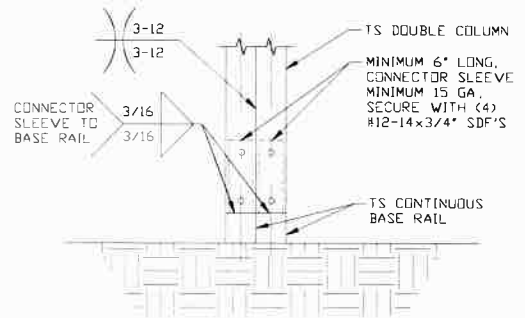

**2** RAFTER COLUMN/BASE RAIL CONNECTION DETAIL

SCALE: NTS

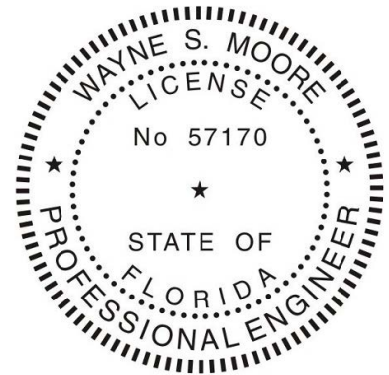

This item has been electronically signed and sealed by Wayne S. Moore, PE, using a Digital Signature and date.

Printed copies of this document are not considered signed and sealed and the signature must be verified on any electronic copies.

**MOORE AND ASSOCIATES  
ENGINEERING AND CONSULTING, INC.**

**DRAWN BY:** JG

**CHECKED BY:** PDH

**PROJECT MGR:** WSM

**CLIENT:** TBS

**TUBULAR BUILDING SYSTEMS  
631 SE INDUSTRIAL CIRCLE  
LAKE CITY, FLORIDA 32025  
30'-0" x 20'-0" ENCLOSED BUILDING EXP. B**

**DATE:** 7-29-21

**SCALE:** NTS

**JOB NO:** 16022S/  
17300S/20352S

**SHT.** 8

**DWG. NO:** SK-3

**REV.:** 6

THIS DOCUMENT IS THE PROPERTY OF MOORE AND ASSOCIATES ENGINEERING AND CONSULTING. THE UNAUTHORIZED REPRODUCTION, COPYING, OR OTHERWISE USE OF THIS DOCUMENT IS STRICTLY PROHIBITED AND ANY INFRINGEMENT THEREUPON MAY BE SUBJECT TO LEGAL ACTION.

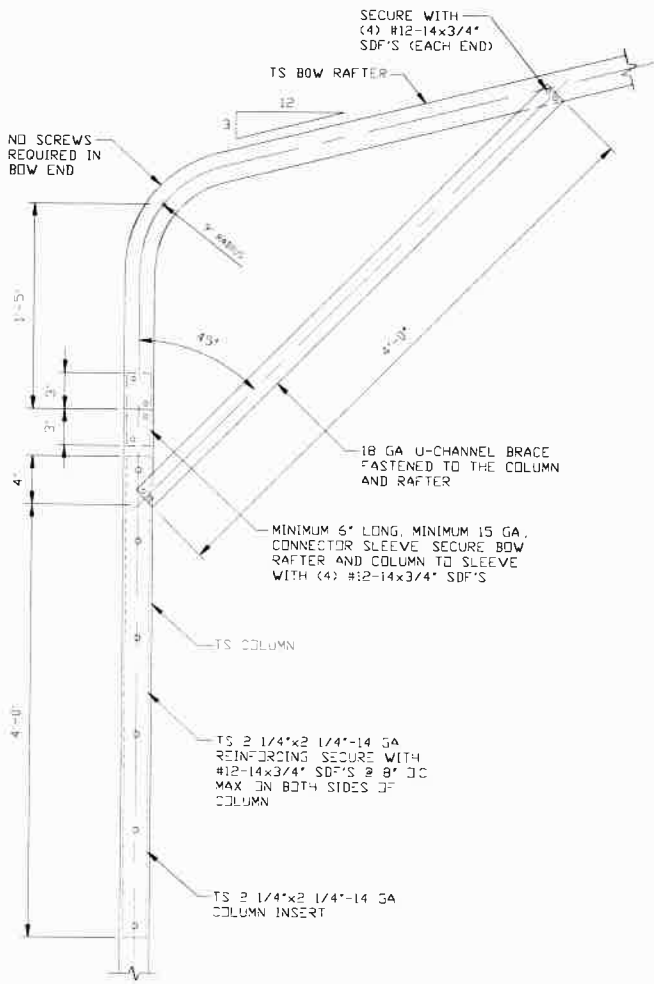

**1A**  
**BOX EAVE RAFTER COLUMN CONNECTION DETAIL FOR HEIGHTS 10'-0" < TO ≤ 13'-0"**  
 SCALE: NTS  
 NOTE: MAXIMUM COLUMN HEIGHT IS 12'-0" FOR HIGH WIND

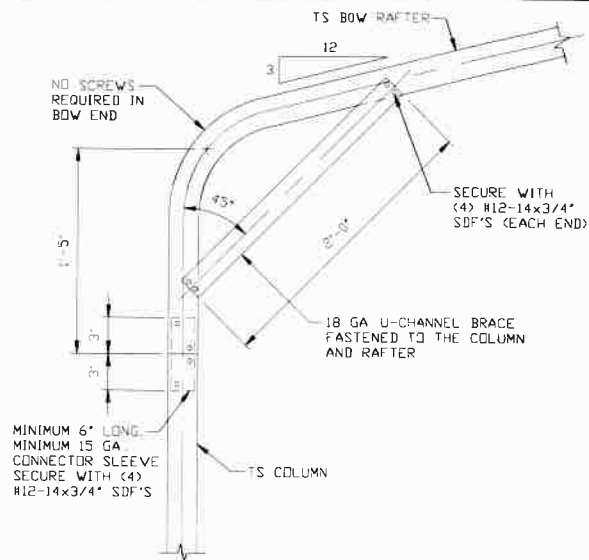

**1B**  
**BOX EAVE RAFTER COLUMN CONNECTION DETAIL FOR HEIGHTS ≤ 10'-0"**  
 SCALE: NTS

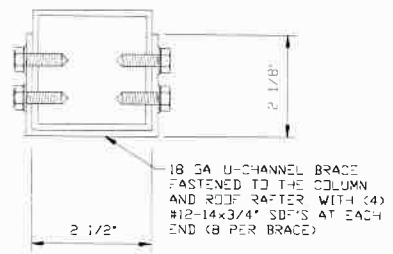

**BRACE SECTION**  
 SCALE: NTS

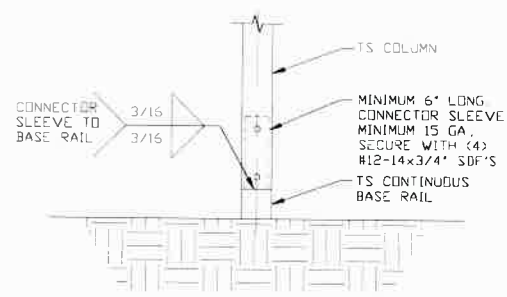

**2**  
**RAFTER COLUMN/BASE RAIL CONNECTION DETAIL**  
 SCALE: NTS



This item has been electronically signed and sealed by Wayne S. Moore, PE, using a Digital Signature and date.

Printed copies of this document are not considered signed and sealed and the signature must be verified on any electronic copies.

**MOORE AND ASSOCIATES ENGINEERING AND CONSULTING, INC.**

DRAWN BY: JG		TUBULAR BUILDING SYSTEMS	
CHECKED BY: PDH		631 SE INDUSTRIAL CIRCLE	
PROJECT MGR: WSM		LAKE CITY, FLORIDA 32025	
CLIENT: TBS		DATE: 7-29-21	30'-0" x 20'-0" ENCLOSED BUILDING EXP. B
		SCALE: NTS	JOB NO: 16022S/17300S/20352S
		SHT. 8A	REV. 6
		DWG. NO: SK-3	

THIS DOCUMENT IS THE PROPERTY OF MOORE AND ASSOCIATES ENGINEERING AND CONSULTING. THE UNAUTHORIZED REPRODUCTION, COPYING, OR OTHERWISE USE OF THIS DOCUMENT IS STRICTLY PROHIBITED AND ANY INFRINGEMENT THEREUPON MAY BE SUBJECT TO LEGAL ACTION.

# BASE RAIL ANCHORAGE OPTIONS FOR LOW AND HIGH WIND SPEED

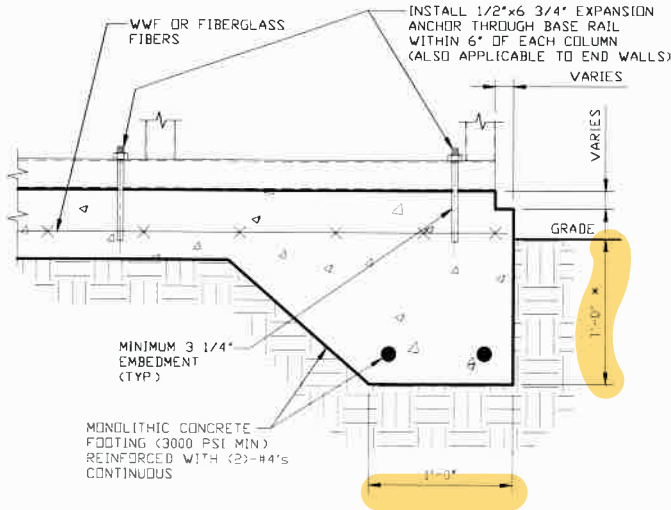

**3A CONCRETE MONOLITHIC SLAB BASE RAIL ANCHORAGE**

SCALE: NTS  
 MINIMUM ANCHOR EDGE DISTANCE IS 4"  
 \* COORDINATE WITH LOCAL CODES/ORD REGARDING MINIMUM FROST DEPTH REQ

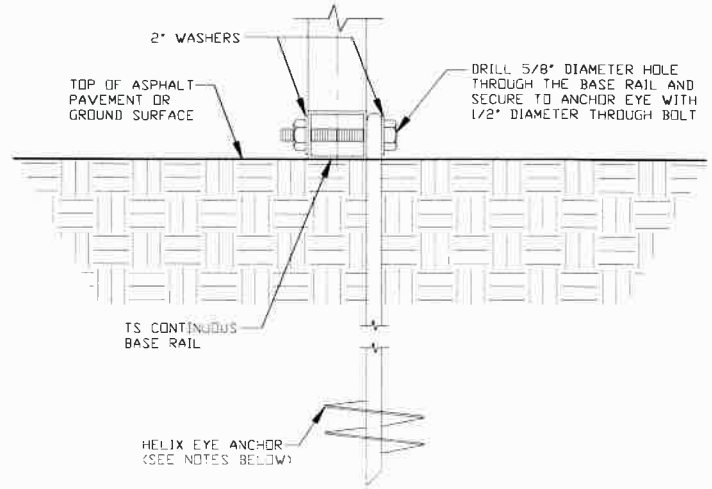

**3B GROUND BASE HELIX ANCHORAGE**

SCALE: NTS  
 (CAN BE USED FOR ASPHALT)  
 \* COORDINATE WITH LOCAL CODES/ORD REGARDING MINIMUM FROST DEPTH REQ

## GENERAL NOTES

NOTE: CONCRETE MONOLITHIC SLAB DESIGN ON MINIMUM SOIL BEARING CAPACITY OF 1500 PSF

### CONCRETE:

CONCRETE SHALL HAVE A MINIMUM SPECIFIED COMPRESSIVE STRENGTH OF 3,000 PSI AT 28 DAYS

### COVER OVER REINFORCING STEEL:

FOR FOUNDATIONS, MINIMUM CONCRETE COVER OVER REINFORCING BARS SHALL BE PER ACI-318  
 3 INCHES IN FOUNDATIONS WHERE THE CONCRETE IS CAST AGAINST AND PERMANENTLY IN CONTACT WITH THE EARTH OR EXPOSED TO THE EARTH OR WEATHER, AND 1 1/2 INCHES ELSEWHERE

### REINFORCING STEEL:

THE TURNDOWN REINFORCING STEEL SHALL BE ASTM A615 GRADE 50 THE SLAB REINFORCEMENT SHALL BE WELDED WIRE FABRIC MEETING ASTM A185 OR FIBERGLASS FIBER REINFORCEMENT

### REINFORCEMENT MAY BE BENT IN THE SHOP OR THE FIELD PROVIDED:

- 1 REINFORCEMENT IS BENT COLD
- 2 THE DIAMETER OF THE BEND, MEASURED ON THE INSIDE OF THE BAR, IS NOT LESS THAN SIX-BAR DIAMETERS
- 3 REINFORCEMENT PARTIALLY EMBEDDED IN CONCRETE SHALL NOT BE FIELD BENT

### HELIX ANCHOR NOTES:

- 1 FOR VERY DENSE AND/OR CEMENTED SANDS COARSE GRAVEL AND COBBLES, CALICHE, PRELDADED SILTS AND CLAYS USE MINIMUM (2) 4" HELICES WITH MINIMUM 30 INCH EMBEDMENT
- 2 FOR CORAL USE MINIMUM (2) 4" HELICES WITH MINIMUM 30 INCH EMBEDMENT
- 3 FOR MEDIUM DENSE COARSE SANDS, SANDY GRAVELS, VERY STIFF SILTS, AND CLAYS USE MINIMUM (2) 4" HELICES WITH MINIMUM 30 INCH EMBEDMENT
- 4 FOR LOOSE TO MEDIUM DENSE SANDS, FIRM TO STIFF CLAYS AND SILTS ALLUVIAL FILL USE MINIMUM (2) 6" HELICES WITH MINIMUM 50 INCH EMBEDMENT
- 5 FOR VERY LOSE TO MEDIUM DENSE SANDS, FIRM TO STIFFER CLAYS AND SILTS, ALLUVIAL FILL USE MINIMUM (2) 8" HELICES WITH MINIMUM 60 INCH EMBEDMENT



This item has been electronically signed and sealed by Wayne S. Moore, PE, using a Digital Signature and date.

Printed copies of this document are not considered signed and sealed and the signature must be verified on any electronic copies.

**MOORE AND ASSOCIATES  
 ENGINEERING AND CONSULTING, INC.**

DRAWN BY: JG

CHECKED BY: PDH

PROJECT MGR: WSM

CLIENT: TBS

TUBULAR BUILDING SYSTEMS  
 631 SE INDUSTRIAL CIRCLE  
 LAKE CITY, FLORIDA 32025  
 30'-0" x 20'-0" ENCLOSED BUILDING EXP. B

DATE: 7-29-21

SCALE: NTS

JOB NO: 16022S/  
 17300S/20352S

SHT. 9

DWG. NO: SK-3

REV: 6

THIS DOCUMENT IS THE PROPERTY OF MOORE AND ASSOCIATES ENGINEERING AND CONSULTING. THE UNAUTHORIZED REPRODUCTION, COPYING, OR OTHERWISE USE OF THIS DOCUMENT IS STRICTLY PROHIBITED AND ANY INFRINGEMENT THEREUPON MAY BE SUBJECT TO LEGAL ACTION.

# OPTIONAL FOUNDATION ANCHORAGE FOR LOW AND HIGH WIND SPEED

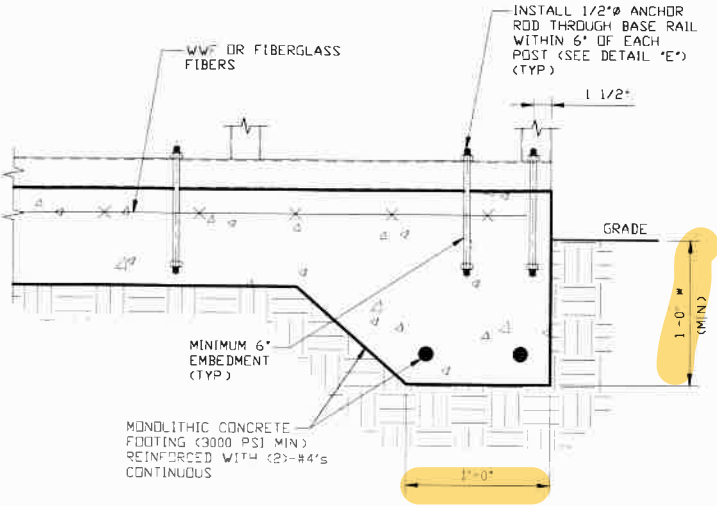

**3C CONCRETE MONOLITHIC SLAB BASE RAIL ANCHORAGE**  
 SCALE: NTS  
 MINIMUM ANCHOR EDGE DISTANCE IS 1 1/2"  
 \* COORDINATE WITH LOCAL CODES/ORD REGARDING MINIMUM FROST DEPTH REQ

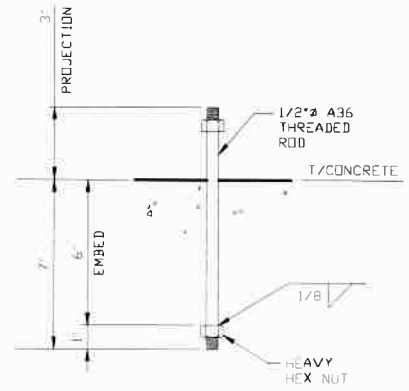

**3D ANCHOR ROD THROUGH BASE RAIL DETAIL**  
 SCALE: NTS

## GENERAL NOTES

NOTE: CONCRETE MONOLITHIC SLAB DESIGN ON MINIMUM SOIL BEARING CAPACITY OF 1,500 PSF

### CONCRETE:

CONCRETE SHALL HAVE A MINIMUM SPECIFIED COMPRESSIVE STRENGTH OF 3,000 PSI AT 28 DAYS

### COVER OVER REINFORCING STEEL:

FOR FOUNDATIONS, MINIMUM CONCRETE COVER OVER REINFORCING BARS SHALL BE PER ACI-318  
 3 INCHES IN FOUNDATIONS WHERE THE CONCRETE IS CAST AGAINST AND PERMANENTLY IN CONTACT WITH THE EARTH OR EXPOSED TO THE EARTH OR WEATHER, AND 1 1/2 INCHES ELSEWHERE

### REINFORCING STEEL:

THE TURNDOWN REINFORCING STEEL SHALL BE ASTM A615 GRADE 60 THE SLAB REINFORCEMENT SHALL BE WELDED WIRE FABRIC MEETING ASTM A185 OR FIBERGLASS FIBER REINFORCEMENT

### REINFORCEMENT MAY BE BENT IN THE SHOP OR THE FIELD PROVIDED:

- 1 REINFORCEMENT IS BENT COLD
- 2 THE DIAMETER OF THE BEND MEASURED ON THE INSIDE OF THE BAR, IS NOT LESS THAN SIX-BAR DIAMETERS
- 3 REINFORCEMENT PARTIALLY EMBEDDED IN CONCRETE SHALL NOT BE FIELD BENT



This item has been electronically signed and sealed by Wayne S. Moore, PE, using a Digital Signature and date.

Printed copies of this document are not considered signed and sealed and the signature must be verified on any electronic copies.

**MOORE AND ASSOCIATES  
 ENGINEERING AND CONSULTING, INC.**

**DRAWN BY:** JG

**CHECKED BY:** PDH

**PROJECT MGR:** WSM

**CLIENT:** TBS

**TUBULAR BUILDING SYSTEMS  
 631 SE INDUSTRIAL CIRCLE  
 LAKE CITY, FLORIDA 32025  
 30'-0" x 20'-0" ENCLOSED BUILDING EXP. B**

**DATE:** 7-29-21

**SHT.** 9A

**SCALE:** NTS

**DWG. NO.:** SK-3

**JOB NO.:** 16022S/  
 17300S/20352S

**REV.:** 6

THIS DOCUMENT IS THE PROPERTY OF MOORE AND ASSOCIATES ENGINEERING AND CONSULTING. THE UNAUTHORIZED REPRODUCTION, COPYING, OR OTHERWISE USE OF THIS DOCUMENT IS STRICTLY PROHIBITED AND ANY INFRINGEMENT THEREUPON MAY BE SUBJECT TO LEGAL ACTION.

# BASE RAIL ANCHORAGE OPTION

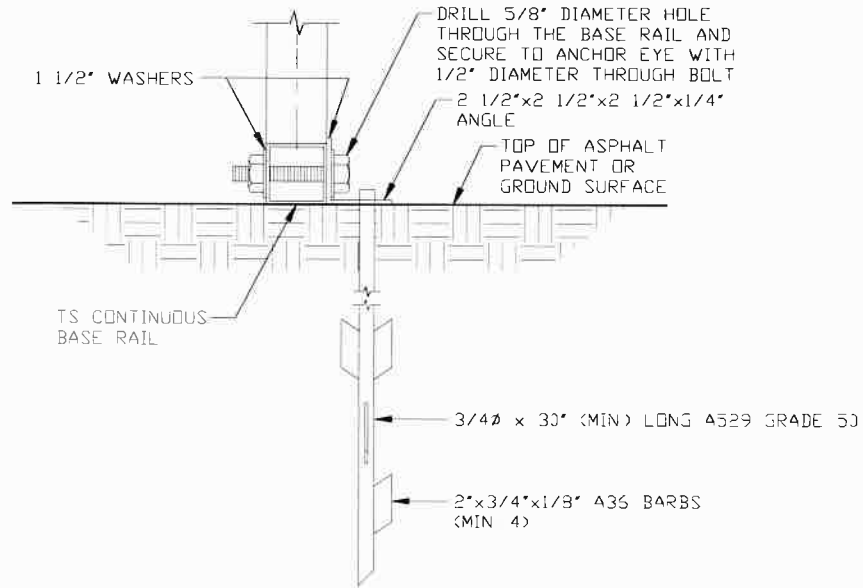

## 3E ASPHALT BASE ANCHORAGE (HP 9 BARBED DRIVE ANCHOR)

SCALE: NTS  
 (CAN BE USED FOR ASPHALT)  
 \* COORDINATE WITH LOCAL CODES/ORD  
 REGARDING MINIMUM FROST DEPTH REQ



This item has been electronically signed and sealed by Wayne S. Moore, PE, using a Digital Signature and date.

Printed copies of this document are not considered signed and sealed and the signature must be verified on any electronic copies.

**MOORE AND ASSOCIATES  
 ENGINEERING AND CONSULTING, INC.**

**DRAWN BY:** JG

**CHECKED BY:** PDH

**PROJECT MGR:** WSM

**CLIENT:** TBS

**TUBULAR BUILDING SYSTEMS  
 631 SE INDUSTRIAL CIRCLE  
 LAKE CITY, FLORIDA 32025  
 30'-0" x 20'-0" ENCLOSED BUILDING EXP. B**

**DATE:** 7-29-21

**SHT.** 9B

**SCALE:** NTS

**DWG. NO:** SK-3

**JOB NO:** 16022S/  
 17300S/20352S

**REV.:** 6

THIS DOCUMENT IS THE PROPERTY OF MOORE AND ASSOCIATES ENGINEERING AND CONSULTING. THE UNAUTHORIZED REPRODUCTION, COPYING, OR OTHERWISE USE OF THIS DOCUMENT IS STRICTLY PROHIBITED AND ANY INFRINGEMENT THEREUPON MAY BE SUBJECT TO LEGAL ACTION.

# BASE RAIL ANCHORAGE OPTIONS

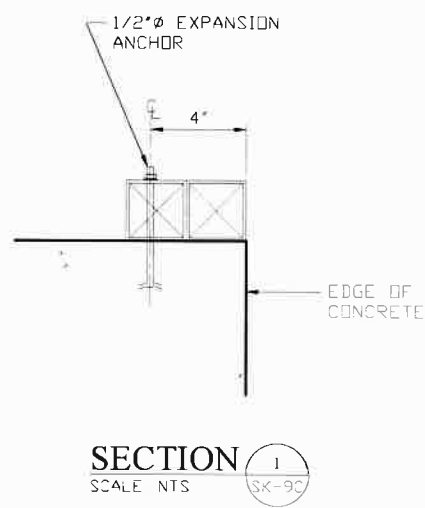
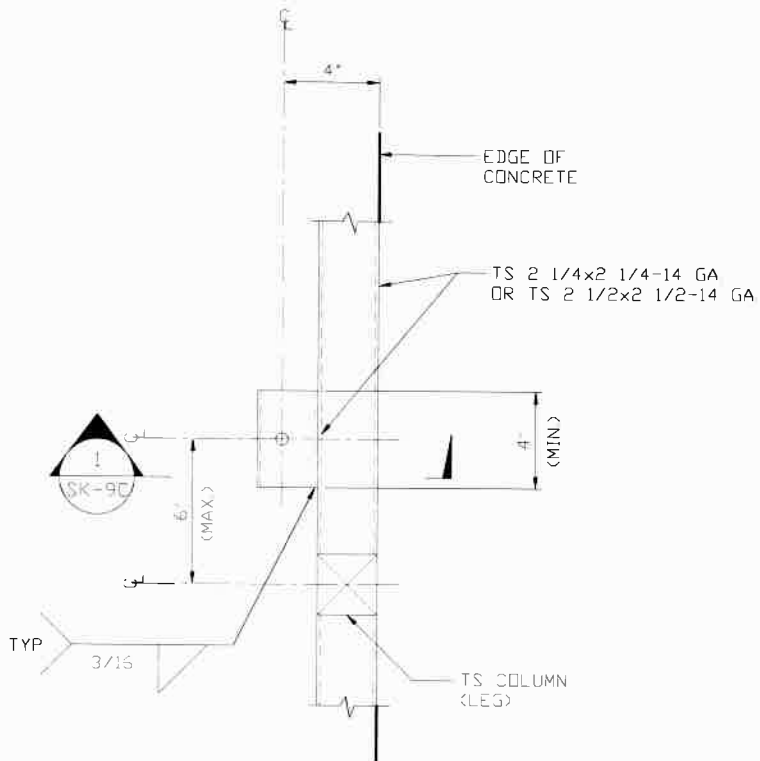

**TYPICAL ANCHOR DETAIL WHEN BASE RAIL IS NEAR EDGE OF CONCRETE**

SCALE: NTS

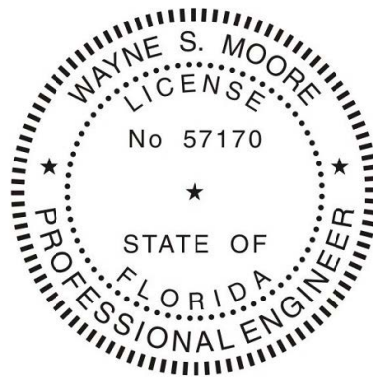

This item has been electronically signed and sealed by Wayne S. Moore, PE. using a Digital Signature and date.

Printed copies of this document are not considered signed and sealed and the signature must be verified on any electronic copies.

**MOORE AND ASSOCIATES  
ENGINEERING AND CONSULTING, INC.**

**DRAWN BY: JG**

**CHECKED BY: PDH**

**PROJECT MGR: WSM**

**CLIENT: TBS**

**TUBULAR BUILDING SYSTEMS  
631 SE INDUSTRIAL CIRCLE  
LAKE CITY, FLORIDA 32025  
30'-0" x 20'-0" ENCLOSED BUILDING EXP. B**

**DATE: 7-29-21**

**SHT. 9C**

**SCALE: NTS**

**DWG. NO: SK-3**

**JOB NO: 16022S/  
17300S/20352S**

**REV: 6**

THIS DOCUMENT IS THE PROPERTY OF MOORE AND ASSOCIATES ENGINEERING AND CONSULTING. THE UNAUTHORIZED REPRODUCTION, COPYING, OR OTHERWISE USE OF THIS DOCUMENT IS STRICTLY PROHIBITED AND ANY INFRINGEMENT THEREUPON MAY BE SUBJECT TO LEGAL ACTION.

# BOX EAVE RAFTER END WALL AND SIDE WALL OPENINGS

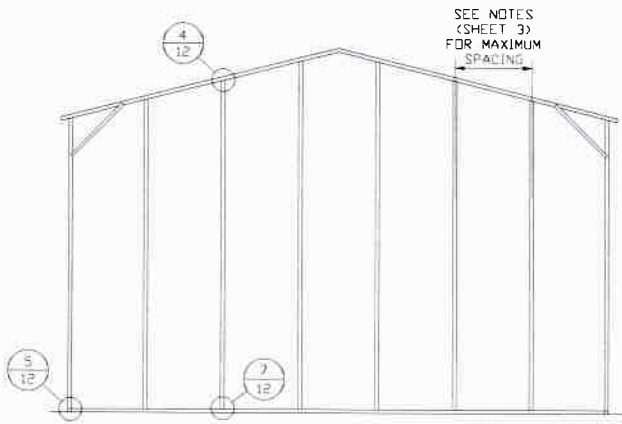

**TYPICAL BOX EAVE RAFTER  
END WALL FRAMING SECTION**

SCALE: NTS

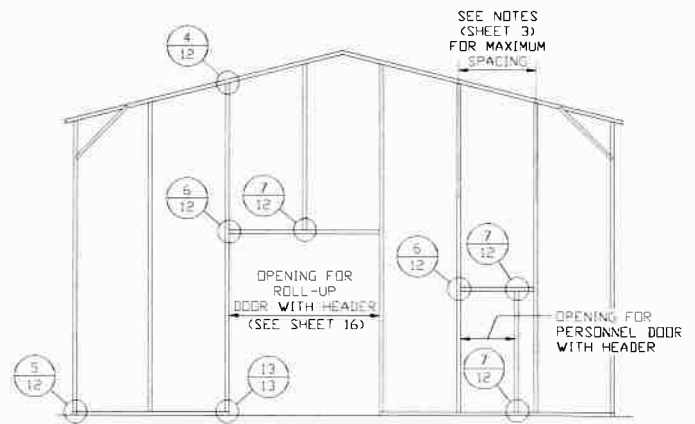

**TYPICAL BOX EAVE RAFTER END  
WALL OPENINGS FRAMING SECTION**

SCALE: NTS

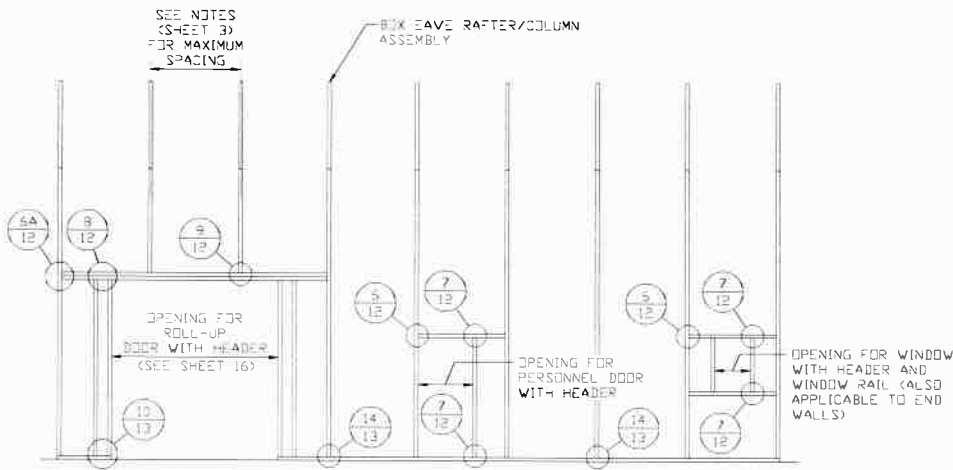

**TYPICAL BOX EAVE RAFTER  
SIDE WALL OPENINGS FRAMING SECTION**

SCALE: NTS



This item has been electronically signed and sealed by Wayne S. Moore, PE. using a Digital Signature and date.

Printed copies of this document are not considered signed and sealed and the signature must be verified on any electronic copies.

**MOORE AND ASSOCIATES  
ENGINEERING AND CONSULTING, INC.**

<b>DRAWN BY:</b> JG	<b>TUBULAR BUILDING SYSTEMS</b> 631 SE INDUSTRIAL CIRCLE LAKE CITY, FLORIDA 32025 30'-0" x 20'-0" ENCLOSED BUILDING EXP. B		
<b>CHECKED BY:</b> PDH			
<b>PROJECT MGR:</b> WSM	<b>DATE:</b> 7-29-21	<b>SCALE:</b> NTS	<b>JOB NO:</b> 16022S/ 17300S/20352S
<b>CLIENT:</b> TBS	<b>SHT.</b> 10	<b>DWG. NO:</b> SK-3	<b>REV.</b> 6

THIS DOCUMENT IS THE PROPERTY OF MOORE AND ASSOCIATES ENGINEERING AND CONSULTING. THE UNAUTHORIZED REPRODUCTION, COPYING, OR OTHERWISE USE OF THIS DOCUMENT IS STRICTLY PROHIBITED AND ANY INFRINGEMENT THEREUPON MAY BE SUBJECT TO LEGAL ACTION.

# BOW RAFTER END WALL AND SIDE WALL OPENINGS

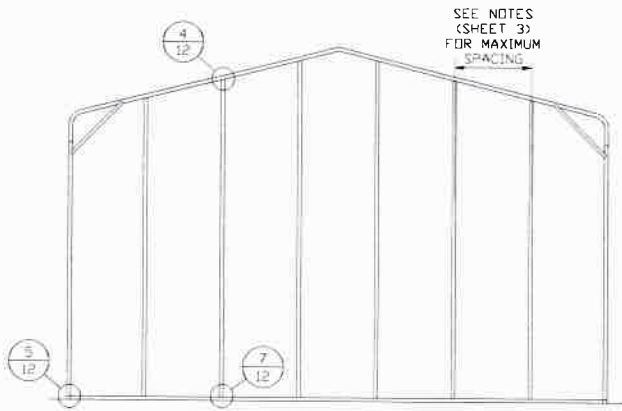

**TYPICAL BOX EAVE RAFTER  
END WALL FRAMING SECTION**

SCALE: NTS

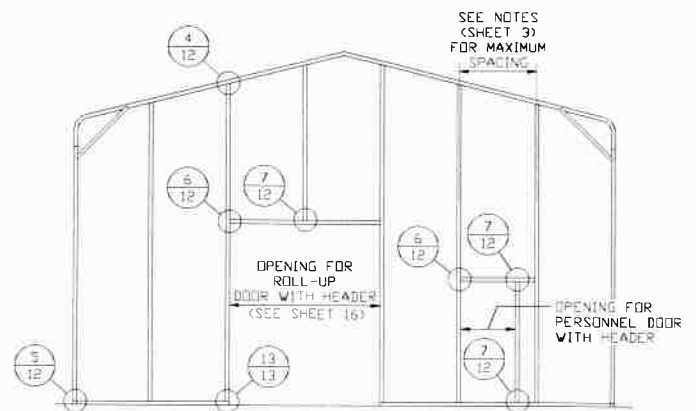

**TYPICAL BOX EAVE RAFTER END  
WALL OPENINGS FRAMING SECTION**

SCALE: NTS

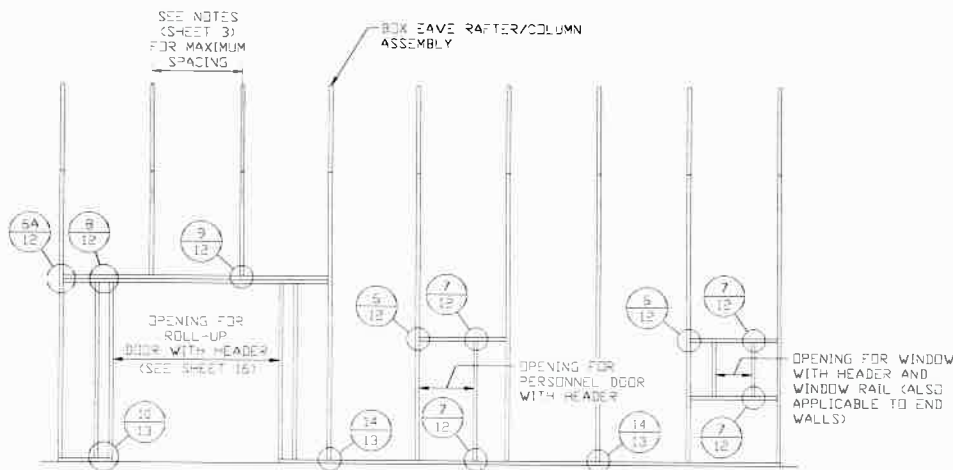

**TYPICAL BOX EAVE RAFTER SIDE  
WALL OPENINGS FRAMING SECTION**

SCALE: NTS

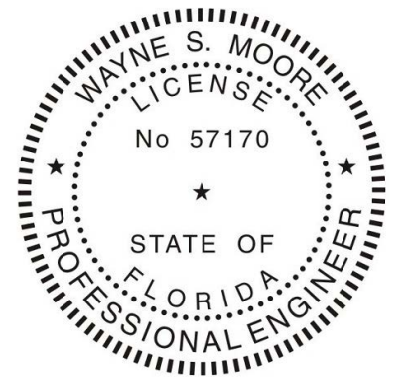

This item has been electronically signed and sealed by Wayne S. Moore, PE, using a Digital Signature and date.

Printed copies of this document are not considered signed and sealed and the signature must be verified on any electronic copies.

**MOORE AND ASSOCIATES  
ENGINEERING AND CONSULTING, INC.**

**DRAWN BY: JG**

**CHECKED BY: PDH**

**PROJECT MGR: WSM**

**CLIENT: TBS**

**TUBULAR BUILDING SYSTEMS  
631 SE INDUSTRIAL CIRCLE  
LAKE CITY, FLORIDA 32025  
30'-0" x 20'-0" ENCLOSED BUILDING EXP. B**

**DATE: 7-29-21**

**SCALE: NTS**

**JOB NO: 16022S/  
17300S/20352S**

**SHT. 11**

**DWG. NO: SK-3**

**REV: 6**

THIS DOCUMENT IS THE PROPERTY OF MOORE AND ASSOCIATES ENGINEERING AND CONSULTING. THE UNAUTHORIZED REPRODUCTION, COPYING, OR OTHERWISE USE OF THIS DOCUMENT IS STRICTLY PROHIBITED AND ANY INFRINGEMENT THEREUPON MAY BE SUBJECT TO LEGAL ACTION.

# CONNECTION DETAILS

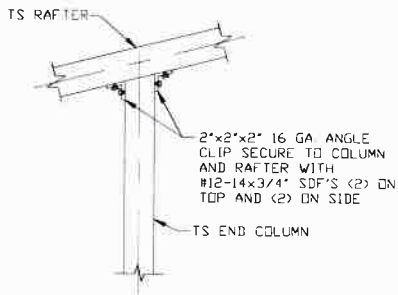

**4** END COLUMN/RAFTER CONNECTION DETAIL

SCALE: NTS

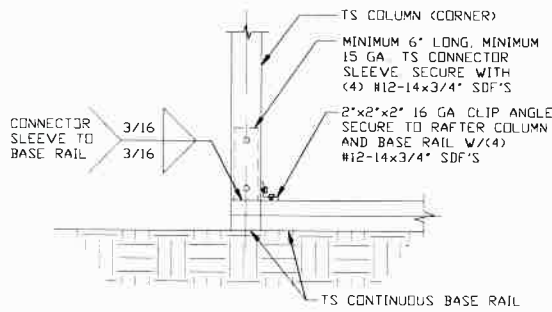

**5** END COLUMN/BASE RAIL CONNECTION DETAIL

SCALE: NTS

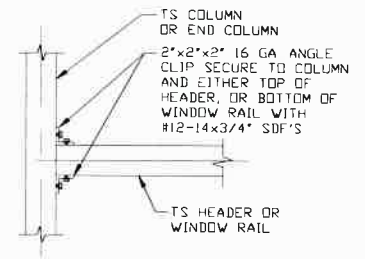

**6** HEADER OR WINDOW RAIL TO COLUMN CONNECTION DETAIL

SCALE: NTS

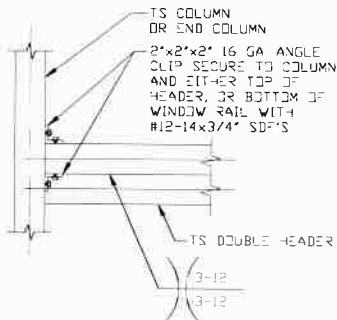

**6A** DOUBLE HEADER TO COLUMN CONNECTION DETAIL

SCALE: NTS

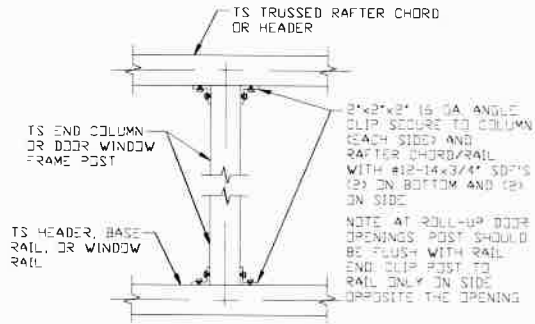

**7** COLUMN TO HEADER, BASE RAIL, OR WINDOW RAIL CONNECTION DETAIL

SCALE: NTS

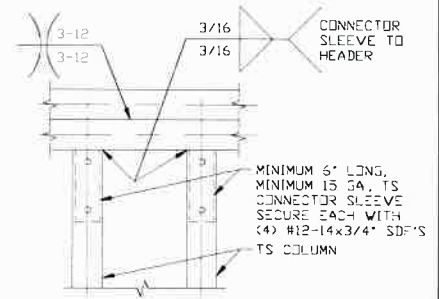

**8** DOUBLE HEADER/COLUMN CONNECTION DETAIL

SCALE: NTS

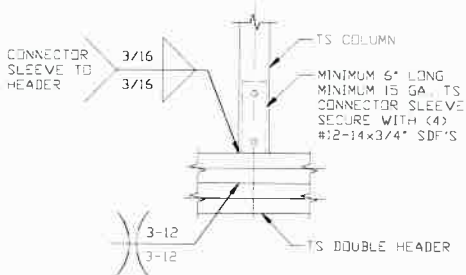

**9** COLUMN/DOUBLE HEADER CONNECTION DETAIL

SCALE: NTS



This item has been electronically signed and sealed by Wayne S. Moore, PE, using a Digital Signature and date.

Printed copies of this document are not considered signed and sealed and the signature must be verified on any electronic copies.

**MOORE AND ASSOCIATES  
ENGINEERING AND CONSULTING, INC.**

DRAWN BY: JG

CHECKED BY: PDH

PROJECT MGR: WSM

CLIENT: TBS

TUBULAR BUILDING SYSTEMS  
631 SE INDUSTRIAL CIRCLE  
LAKE CITY, FLORIDA 32025  
30'-0" x 20'-0" ENCLOSED BUILDING EXP. B

DATE: 7-29-21

SCALE: NTS

JOB NO: 16022S/  
17300S/20352S

SHT. 12

DWG. NO: SK-3

REV: 6

THIS DOCUMENT IS THE PROPERTY OF MOORE AND ASSOCIATES ENGINEERING AND CONSULTING. THE UNAUTHORIZED REPRODUCTION, COPYING, OR OTHERWISE USE OF THIS DOCUMENT IS STRICTLY PROHIBITED AND ANY INFRINGEMENT THEREUPON MAY BE SUBJECT TO LEGAL ACTION.

# CONNECTION DETAILS

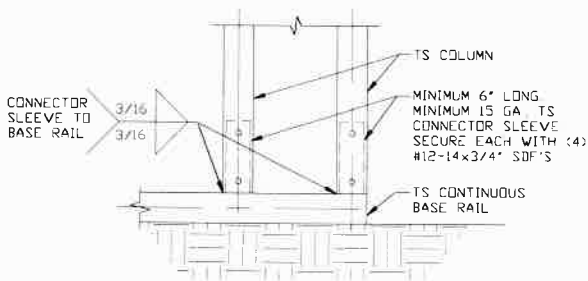

**10** COLUMN/BASE RAIL CONNECTION DETAIL

SCALE: NTS

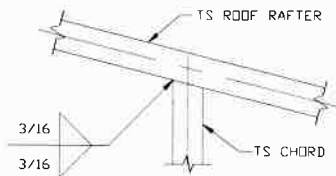

**11** RAFTER TO CHORD CONNECTION DETAIL

SCALE: NTS

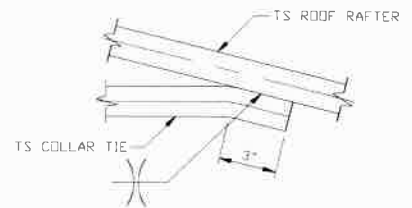

**12** COLLAR TIE CONNECTION DETAIL

SCALE: NTS

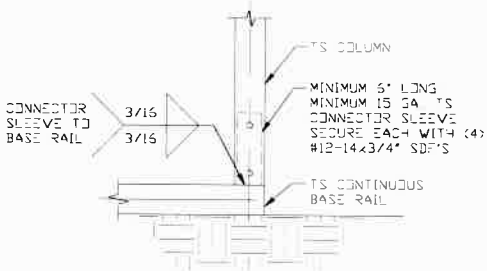

**13** COLUMN/BASE RAIL CONNECTION DETAIL

SCALE: NTS

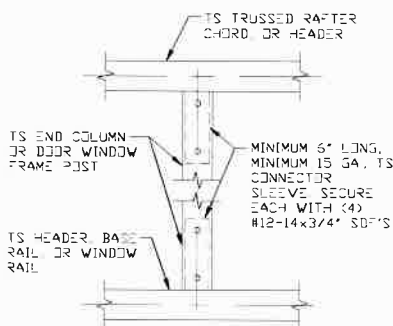

**14** COLUMN TO HEADER, BASE RAIL CONNECTION DETAIL

SCALE: NTS

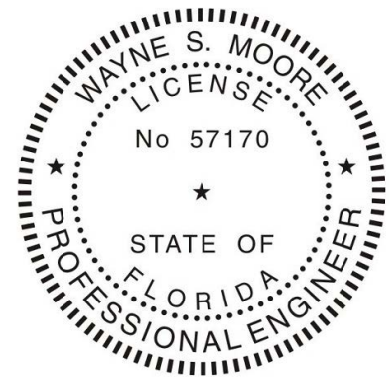

This item has been electronically signed and sealed by Wayne S. Moore, PE, using a Digital Signature and date.

Printed copies of this document are not considered signed and sealed and the signature must be verified on any electronic copies.

**MOORE AND ASSOCIATES  
ENGINEERING AND CONSULTING, INC.**

DRAWN BY: JG

CHECKED BY: PDH

PROJECT MGR: WSM

CLIENT: TBS

TUBULAR BUILDING SYSTEMS  
631 SE INDUSTRIAL CIRCLE  
LAKE CITY, FLORIDA 32025  
30'-0" x 20'-0" ENCLOSED BUILDING EXP. B

DATE: 7-29-21

SCALE: NTS

JOB NO: 16022S/  
17300S/20352S

SHT. 13

DWG. NO: SK-3

REV: 6

THIS DOCUMENT IS THE PROPERTY OF MOORE AND ASSOCIATES ENGINEERING AND CONSULTING. THE UNAUTHORIZED REPRODUCTION, COPYING, OR OTHERWISE USE OF THIS DOCUMENT IS STRICTLY PROHIBITED AND ANY INFRINGEMENT THEREUPON MAY BE SUBJECT TO LEGAL ACTION.

# BOX EAVE RAFTER LEAN-TO OPTIONS

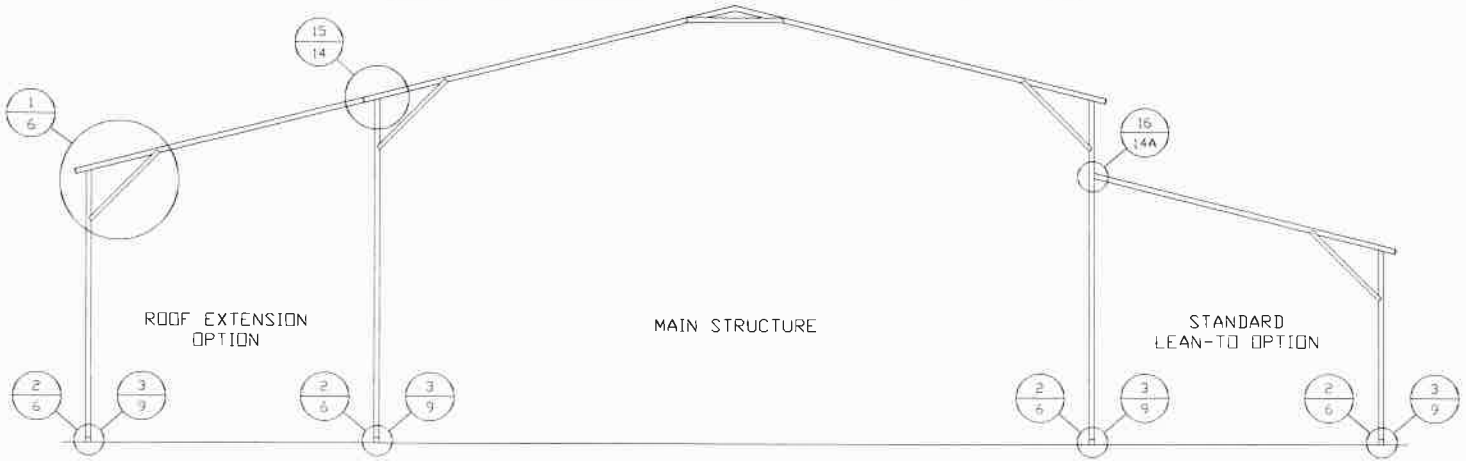

## TYPICAL BOX EAVE RAFTER LEAN-TO OPTIONS FRAMING SECTION (BOTH OPTIONS SHOWN)

SCALE: NTS

MAIN BUILDING COLUMNS WITH LEAN-TO OR ROOF EXTENSION ATTACHED ARE REQUIRED TO BE LACED COLUMNS FOR EAVE HEIGHTS 16'-0" < TO < 20'-0"  
 MAIN BUILDING COLUMNS WITH LEAN-TO OR ROOF EXTENSION ATTACHED ARE REQUIRED TO BE DOUBLE COLUMNS FOR EAVE HEIGHTS 13'-0" (12'-0" FOR HIGH WIND) < TO < 15'-0"  
 MAIN BUILDING COLUMNS WITH LEAN-TO OR ROOF EXTENSION ATTACHED ARE REQUIRED TO BE SINGLE COLUMNS FOR EAVE HEIGHTS 10'-0" < TO < 13'-0" (12'-0" FOR HIGH WIND) (WITH 4'-4" INSERT)  
 MAIN BUILDING COLUMNS WITH LEAN-TO OR ROOF EXTENSION ATTACHED ARE REQUIRED TO BE SINGLE COLUMNS FOR EAVE HEIGHTS < 10'-0"  
 KNEE BRACES MUST BE 4'-0" (5'-0" FOR HIGH WIND) WHEN LEAN-TO'S ARE ADDED.

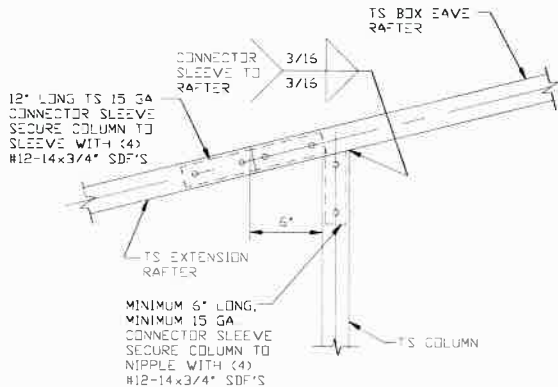

15

### SIDE EXTENSION RAFTER/COLUMN DETAIL FOR RAFTER SPANS <= 15'-0"

SCALE: NTS

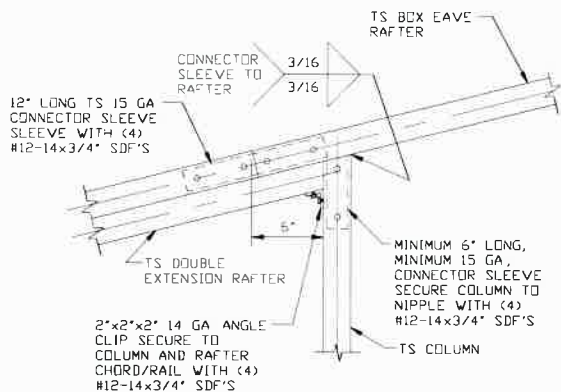

15A

### SIDE EXTENSION RAFTER/COLUMN DETAIL FOR RAFTER SPANS 15'-0" < TO <= 24'-0"

SCALE: NTS

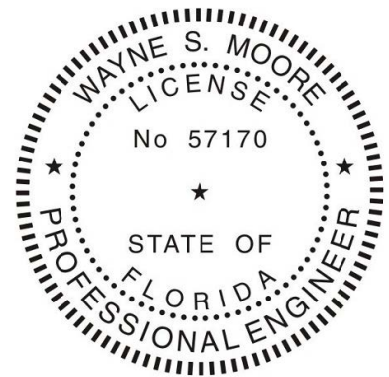

This item has been electronically signed and sealed by Wayne S. Moore, PE. using a Digital Signature and date.

Printed copies of this document are not considered signed and sealed and the signature must be verified on any electronic copies.

**MOORE AND ASSOCIATES  
ENGINEERING AND CONSULTING, INC.**

DRAWN BY: JG

CHECKED BY: PDH

PROJECT MGR: WSM

CLIENT: TBS

TUBULAR BUILDING SYSTEMS  
631 SE INDUSTRIAL CIRCLE  
LAKE CITY, FLORIDA 32025  
30'-0" x 20'-0" ENCLOSED BUILDING EXP. B

DATE: 7-29-21

SHT. 14

SCALE: NTS

DWG. NO: SK-3

JOB NO: 16022S/  
17300S/20352S

REV: 6

THIS DOCUMENT IS THE PROPERTY OF MOORE AND ASSOCIATES ENGINEERING AND CONSULTING. THE UNAUTHORIZED REPRODUCTION, COPYING, OR OTHERWISE USE OF THIS DOCUMENT IS STRICTLY PROHIBITED AND ANY INFRINGEMENT THEREUPON MAY BE SUBJECT TO LEGAL ACTION.

# BOX EAVE RAFTER LEAN-TO OPTIONS

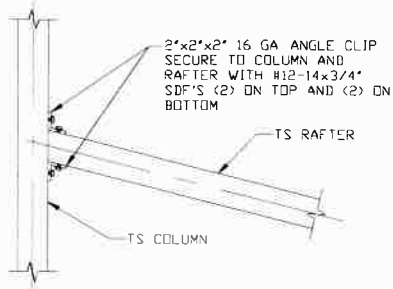

**LEAN-TO RAFTER TO RAFTER  
COLUMN CONNECTION DETAIL  
FOR RAFTER SPANS  $\leq 15'-0''$**

16

SCALE: NTS

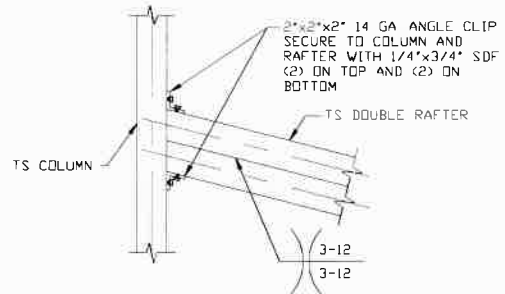

**LEAN-TO RAFTER TO RAFTER  
COLUMN CONNECTION DETAIL  
FOR RAFTER SPANS  
 $15'-0'' < TO \leq 24'-0''$**

16A

SCALE: NTS



This item has been electronically signed and sealed by Wayne S. Moore, PE. using a Digital Signature and date.

Printed copies of this document are not considered signed and sealed and the signature must be verified on any electronic copies.

**MOORE AND ASSOCIATES  
ENGINEERING AND CONSULTING, INC.**

DRAWN BY: JG

CHECKED BY: PDH

PROJECT MGR: WSM

CLIENT: TBS

TUBULAR BUILDING SYSTEMS  
631 SE INDUSTRIAL CIRCLE  
LAKE CITY, FLORIDA 32025  
30'-0" x 20'-0" ENCLOSED BUILDING EXP. B

DATE: 7-29-21

SCALE: NTS

JOB NO: 16022S/  
17300S/20352S

SHT. 14A

DWG. NO: SK-3

REV.: 6

THIS DOCUMENT IS THE PROPERTY OF MOORE AND ASSOCIATES ENGINEERING AND CONSULTING. THE UNAUTHORIZED REPRODUCTION, COPYING, OR OTHERWISE USE OF THIS DOCUMENT IS STRICTLY PROHIBITED AND ANY INFRINGEMENT THEREUPON MAY BE SUBJECT TO LEGAL ACTION.

# BOW RAFTER LEAN-TO OPTIONS

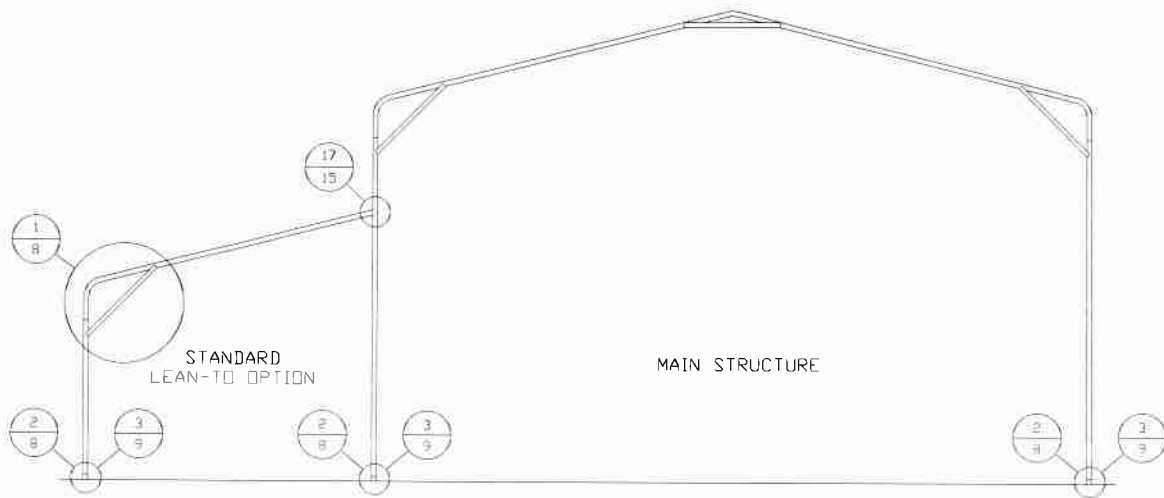

## TYPICAL BOW RAFTER LEAN-TO OPTIONS FRAMING SECTION (BOTH OPTIONS SHOWN)

SCALE: NTS

MAIN BUILDING COLUMNS WITH LEAN-TO OR ROOF EXTENSION ATTACHED ARE REQUIRED TO BE DOUBLE COLUMNS FOR EAVE HEIGHTS 13'-0" (12'-0" FOR HIGH WIND) < TO < 15'-0"

MAIN BUILDING COLUMNS WITH LEAN-TO OR ROOF EXTENSION ATTACHED ARE REQUIRED TO BE SINGLE COLUMNS FOR EAVE HEIGHTS 10'-0" < TO < 13'-0" (12'-0" FOR HIGH WIND) (WITH 4'-4" INSERT)

MAIN BUILDING COLUMNS WITH LEAN-TO OR ROOF EXTENSION ATTACHED ARE REQUIRED TO BE SINGLE COLUMNS FOR EAVE HEIGHTS < 10'-0"

KNEE BRACES MUST BE 4'-0" (5'-0" FOR HIGH WIND) WHEN LEAN-TO'S ARE ADDED

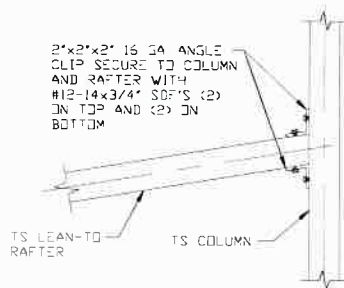

### LEAN-TO RAFTER TO RAFTER COLUMN CONNECTION DETAIL FOR RAFTER SPANS ≤ 15'-0"

17

SCALE: NTS

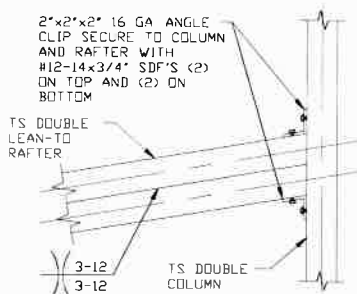

### LEAN-TO RAFTER TO RAFTER COLUMN CONNECTION DETAIL FOR RAFTER SPANS 15'-0" < TO ≤ 24'-0"

17A

SCALE: NTS



This item has been electronically signed and sealed by Wayne S. Moore, PE. using a Digital Signature and date.

Printed copies of this document are not considered signed and sealed and the signature must be verified on any electronic copies.

**MOORE AND ASSOCIATES  
ENGINEERING AND CONSULTING, INC.**

**DRAWN BY: JG**

**CHECKED BY: PDH**

**PROJECT MGR: WSM**

**CLIENT: TBS**

TUBULAR BUILDING SYSTEMS  
631 SE INDUSTRIAL CIRCLE  
LAKE CITY, FLORIDA 32025  
30'-0"x20'-0" ENCLOSED BUILDING EXP. B

**DATE: 7-29-21**

**SCALE: NTS**

**JOB NO: 16022S/  
17300S/20352S**

**SHT. 15**

**DWG. NO: SK-3**

**REV: 6**

THIS DOCUMENT IS THE PROPERTY OF MOORE AND ASSOCIATES ENGINEERING AND CONSULTING. THE UNAUTHORIZED REPRODUCTION, COPYING, OR OTHERWISE USE OF THIS DOCUMENT IS STRICTLY PROHIBITED AND ANY INFRINGEMENT THEREUPON MAY BE SUBJECT TO LEGAL ACTION.

# BOX EAVE RAFTER VERTICAL ROOF/SIDING OPTION

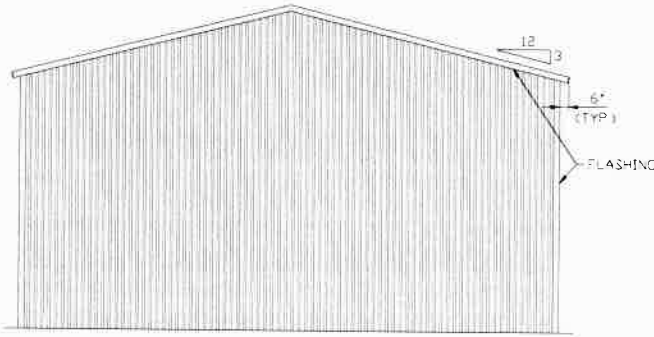

**TYPICAL END ELEVATION  
VERTICAL ROOF/SIDING OPTION**

SCALE: NTS

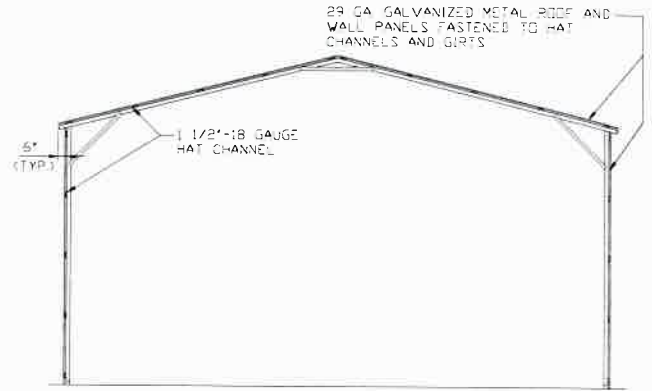

**TYPICAL SECTION VERTICAL  
ROOF/SIDING OPTION**

SCALE: NTS

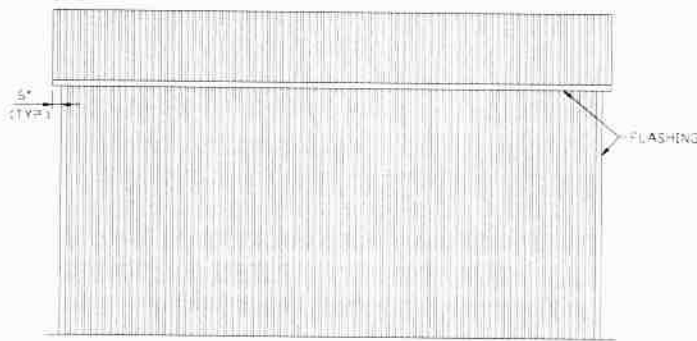

**TYPICAL SIDE ELEVATION  
VERTICAL ROOF/SIDING OPTION**

SCALE: NTS

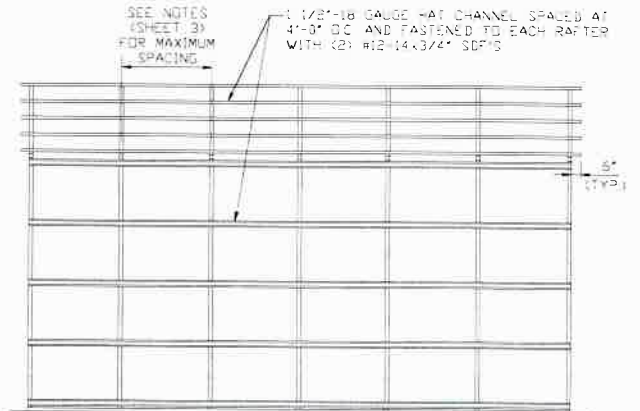

**TYPICAL FRAMING SECTION  
VERTICAL ROOF/SIDING OPTION**

SCALE: NTS

NOTE: ITS WALL GIRTS CAN BE USED AS AN OPTION IN PLACE OF HAT CHANNELS. ITS GIRTS MUST BE SPACED AT 4'-0" (MAX) OC.

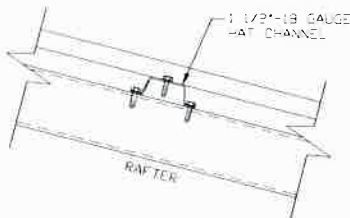

**ROOF PANEL ATTACHMENT**

(ALTERNATE FOR VERTICAL ROOF PANELS)  
SCALE: NTS



This item has been electronically signed and sealed by Wayne S. Moore, PE, using a Digital Signature and date.

Printed copies of this document are not considered signed and sealed and the signature must be verified on any electronic copies.

**MOORE AND ASSOCIATES  
ENGINEERING AND CONSULTING, INC.**

**DRAWN BY:** JG

**CHECKED BY:** PDH

**PROJECT MGR:** WSM

**CLIENT:** TBS

**TUBULAR BUILDING SYSTEMS  
631 SE INDUSTRIAL CIRCLE  
LAKE CITY, FLORIDA 32025  
30'-0"x20'-0" ENCLOSED BUILDING EXP. B**

**DATE:** 7-29-21

**SHT.** 16

**SCALE:** NTS

**DWG. NO.:** SK-3

**JOB NO.:** 16022S/  
17300S/20352S

**REV.:** 6

THIS DOCUMENT IS THE PROPERTY OF MOORE AND ASSOCIATES ENGINEERING AND CONSULTING. THE UNAUTHORIZED REPRODUCTION, COPYING, OR OTHERWISE USE OF THIS DOCUMENT IS STRICTLY PROHIBITED AND ANY INFRINGEMENT THEREUPON MAY BE SUBJECT TO LEGAL ACTION.

## SIDE WALL HEADER OPTIONS

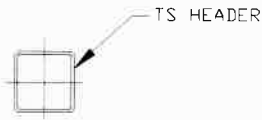

**HEADER DETAIL FOR DOOR  
OPENINGS  $\leq 10'-0''$**

SCALE: NTS

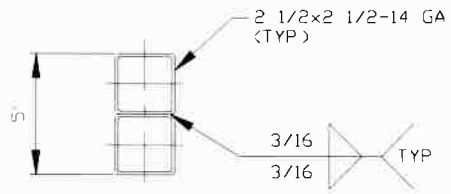

**HEADER DETAIL FOR DOOR  
OPENINGS  $10'-0'' < \text{LENGTH} \leq 15'-0''$**

SCALE: NTS

## END WALL HEADER OPTIONS

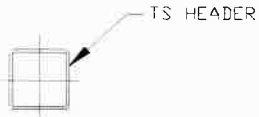

**HEADER DETAIL FOR DOOR  
OPENINGS  $\leq 12'-0''$**

SCALE: NTS

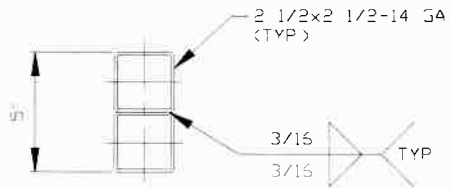

**HEADER DETAIL FOR DOOR  
OPENINGS  $12'-0'' < \text{LENGTH} \leq 15'-0''$**

SCALE: NTS



This item has been electronically signed and sealed by Wayne S. Moore, PE. using a Digital Signature and date.

Printed copies of this document are not considered signed and sealed and the signature must be verified on any electronic copies.

**MOORE AND ASSOCIATES  
ENGINEERING AND CONSULTING, INC.**

**DRAWN BY: JG**

**CHECKED BY: PDH**

**PROJECT MGR: WSM**

**CLIENT: TBS**

**TUBULAR BUILDING SYSTEMS  
631 SE INDUSTRIAL CIRCLE  
LAKE CITY, FLORIDA 32025  
30'-0"x20'-0" ENCLOSED BUILDING EXP. B**

**DATE: 7-29-21**

**SHT. 17**

**SCALE: NTS**

**DWG. NO: SK-3**

**JOB NO: 16022S/  
17300S/20352S**

**REV.: 6**

THIS DOCUMENT IS THE PROPERTY OF MOORE AND ASSOCIATES ENGINEERING AND CONSULTING. THE UNAUTHORIZED REPRODUCTION, COPYING, OR OTHERWISE USE OF THIS DOCUMENT IS STRICTLY PROHIBITED AND ANY INFRINGEMENT THEREUPON MAY BE SUBJECT TO LEGAL ACTION.

## FLOOD VENT DETAIL

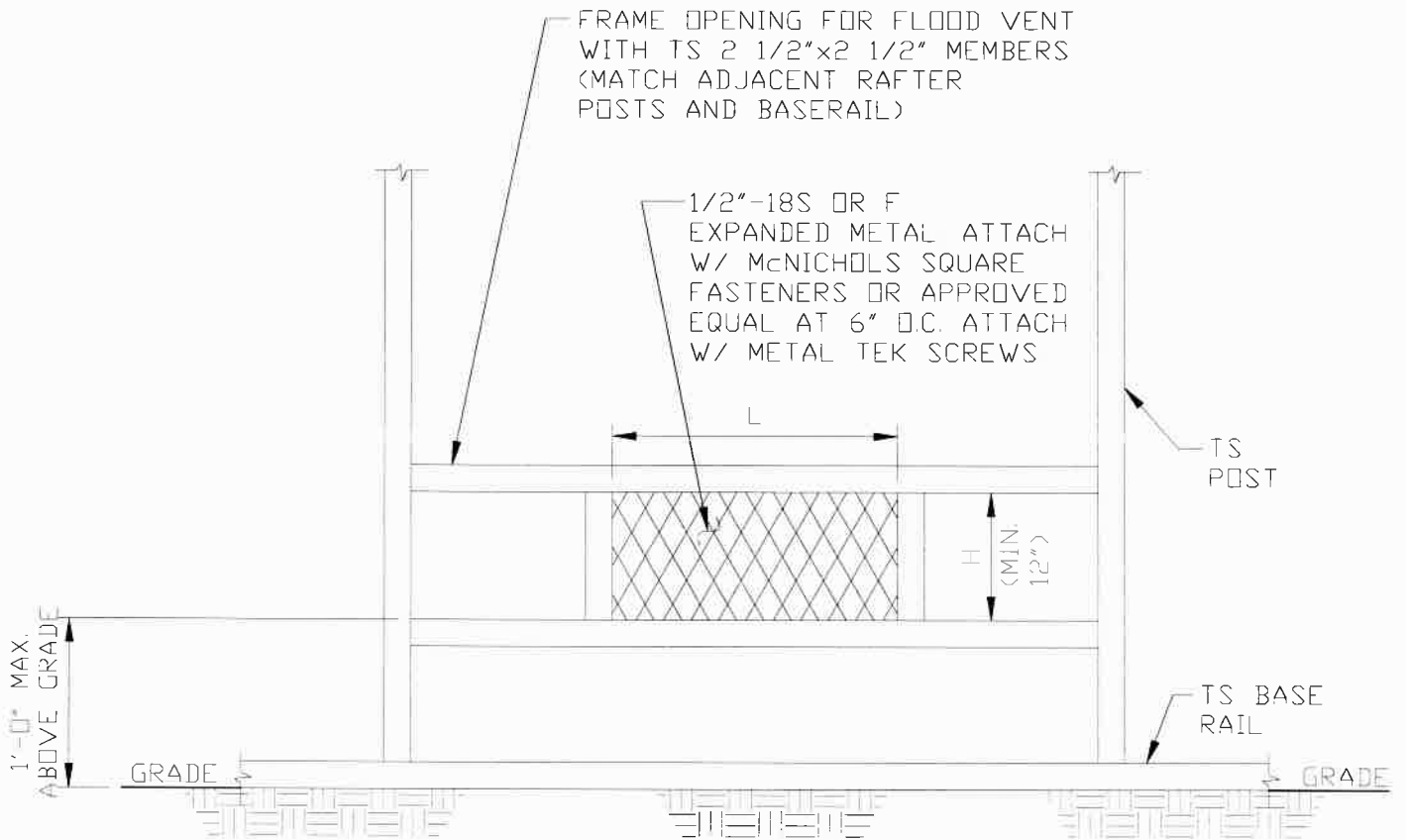

### TYPICAL FLOOD VENT DETAIL

SCALE: NTS

1. MINIMUM VENT SPACE REQUIRED = 1 SQ INCH OF OPEN VENT AREA PER SQ FOOT OF BUILDING AREA
2. THERE SHALL BE A MINIMUM OF TWO OPENINGS ON DIFFERENT SIDES FOR EACH ENCLOSED BUILDING
3. APPLY 13 FACTOR WHEN CALCULATING TOTAL OPEN AREA WHEN USING 1/2"-18GA S OR F EXPANDED METAL.
4. TOTAL OPEN AREA OF VENT =  $L \times H (\text{MIN } 12")$
5. FLOOD VENT DETAIL COMPLIES WITH FEMA/NFIP
6. PREFABRICATED FLOOD VENTS MEETING THE REQUIREMENTS OF FEMA/NIFIP MAY BE USED



This item has been electronically signed and sealed by Wayne S. Moore, PE. using a Digital Signature and date.

Printed copies of this document are not considered signed and sealed and the signature must be verified on any electronic copies.

**MOORE AND ASSOCIATES  
ENGINEERING AND CONSULTING, INC.**

**DRAWN BY: JG**

**CHECKED BY: PDH**

**PROJECT MGR: WSM**

**CLIENT: TBS**

**TUBULAR BUILDING SYSTEMS  
631 SE INDUSTRIAL CIRCLE  
LAKE CITY, FLORIDA 32025  
30'-0"x20'-0" ENCLOSED BUILDING EXP. B**

**DATE: 7-29-21**

**SCALE: NTS**

**SHT. 10**

**DWG. NO: SK-3**

**JOB NO: 16022S/  
17300S/20352S**

**REV.: 6**

THIS DOCUMENT IS THE PROPERTY OF MOORE AND ASSOCIATES ENGINEERING AND CONSULTING. THE UNAUTHORIZED REPRODUCTION, COPYING, OR OTHERWISE USE OF THIS DOCUMENT IS STRICTLY PROHIBITED AND ANY INFRINGEMENT THEREUPON MAY BE SUBJECT TO LEGAL ACTION.

# STAND-ALONE STEM WALL DETAIL

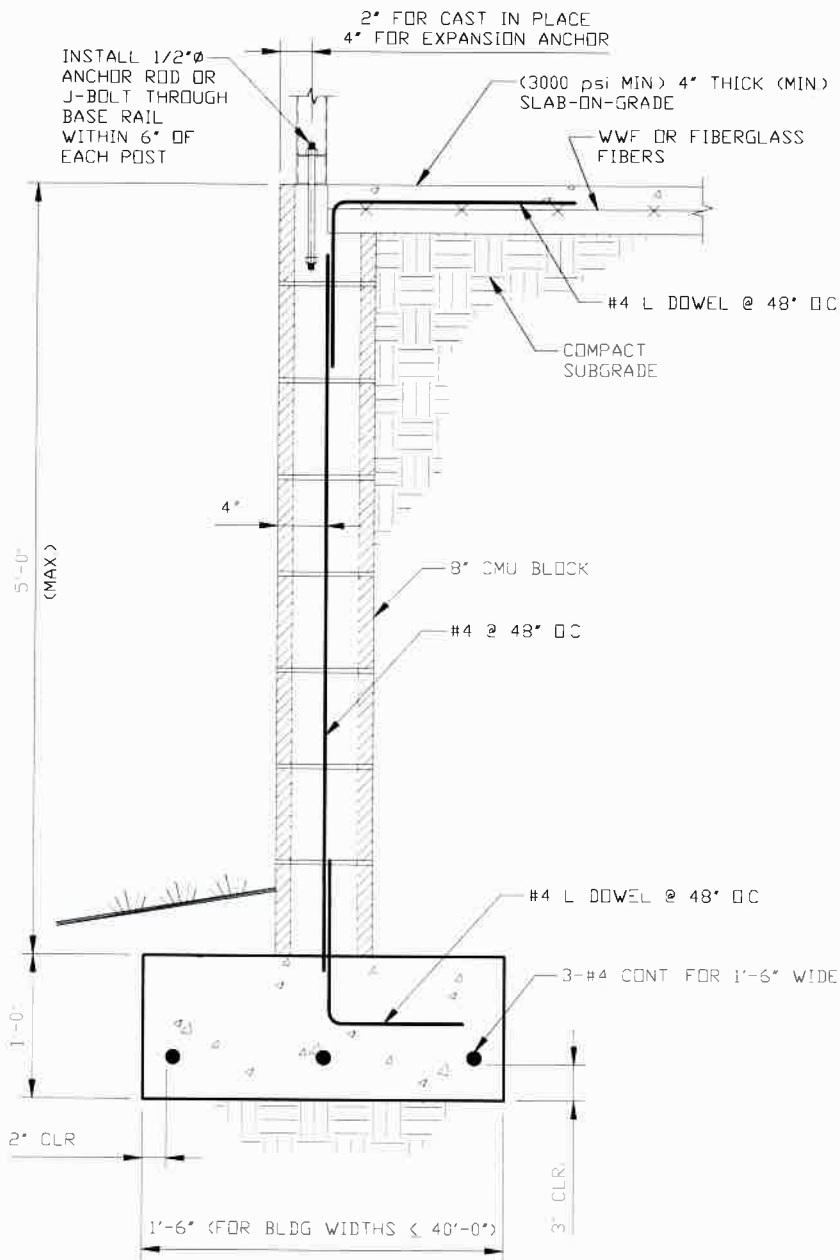

**STAND-ALONE CONCRETE MASONRY UNIT (CMU)  
FOUNDATION STEM WALL DETAIL**

SCALE: NTS



This item has been electronically signed and sealed by Wayne S. Moore, PE. using a Digital Signature and date.

Printed copies of this document are not considered signed and sealed and the signature must be verified on any electronic copies.

**MOORE AND ASSOCIATES  
ENGINEERING AND CONSULTING, INC.**

**DRAWN BY: JG**

**CHECKED BY: PDH**

**PROJECT MGR: WSM**

**CLIENT: TBS**

**TUBULAR BUILDING SYSTEMS  
631 SE INDUSTRIAL CIRCLE  
LAKE CITY, FLORIDA 32025  
30'-0"x20'-0" ENCLOSED BUILDING EXP. B**

**DATE: 7-29-21**

**SCALE: NTS**

**JOB NO: 16022S/  
17300S/20352S**

**SHT. 19**

**DWG. NO: SK-3**

**REV.: 6**

THIS DOCUMENT IS THE PROPERTY OF MOORE AND ASSOCIATES ENGINEERING AND CONSULTING. THE UNAUTHORIZED REPRODUCTION, COPYING, OR OTHERWISE USE OF THIS DOCUMENT IS STRICTLY PROHIBITED AND ANY INFRINGEMENT THEREUPON MAY BE SUBJECT TO LEGAL ACTION.

# VERTICAL SLIDING WINDOW DETAIL

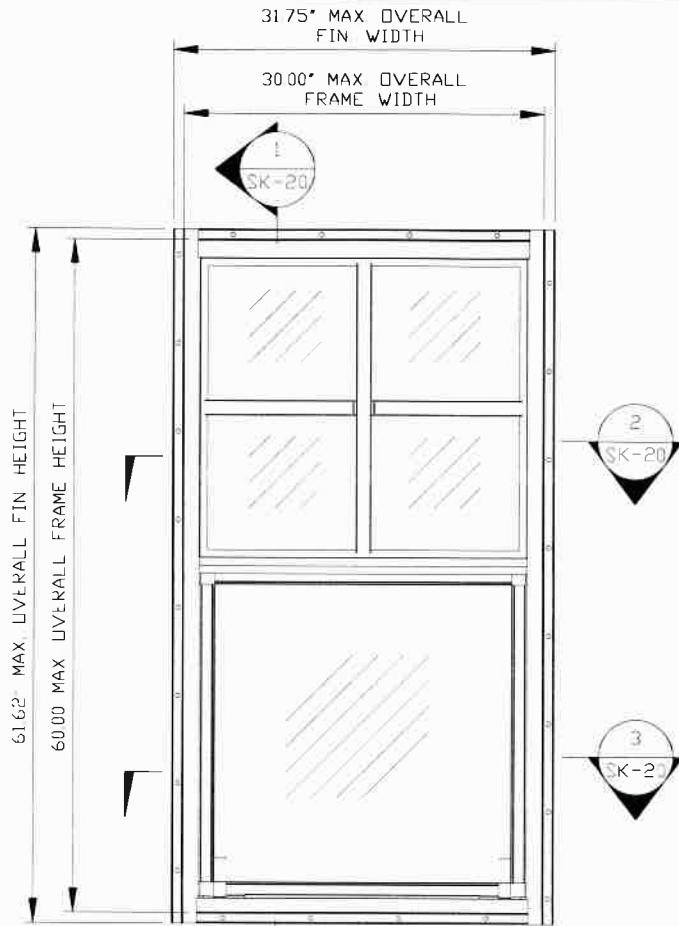

**ELEVATION VIEW**

SCALE: NTS

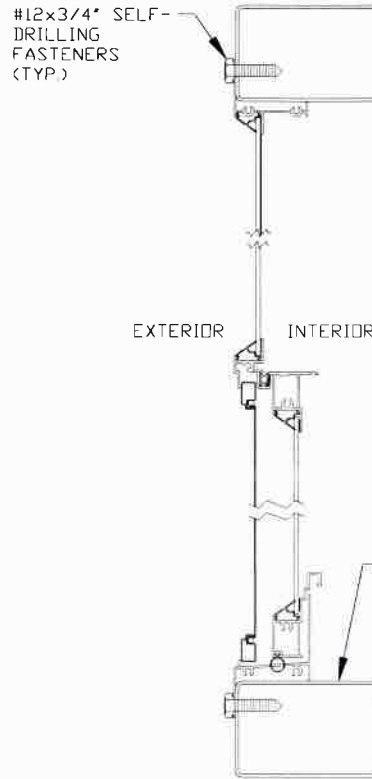

**SECTION 1**  
SCALE: 3"=1'-0" SK-20

NOTE: KINRO SERIES 18000-R VS OR EQUIVALENT WINDOW IS REQUIRED

**POSITIVE WALL PRESSURE: +40.0 PSF**

**NEGATIVE WALL PRESSURE: -40.0 PSF**

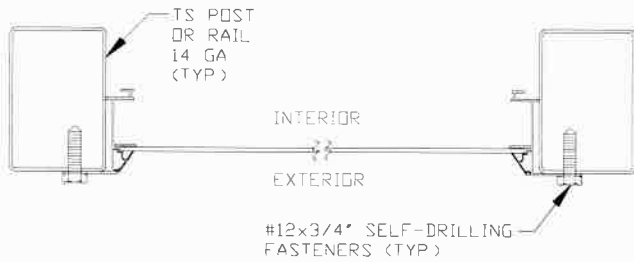

**SECTION 2**  
SCALE: 3"=1'-0" SK-20

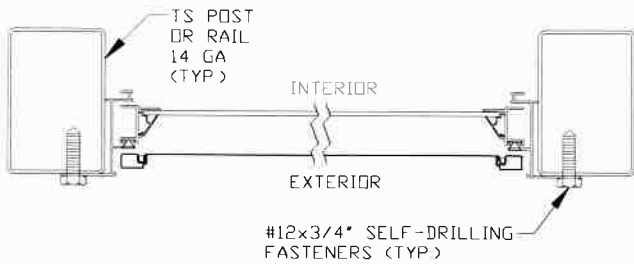

**SECTION 3**  
SCALE: 3"=1'-0" SK-20



This item has been electronically signed and sealed by Wayne S. Moore, PE, using a Digital Signature and date.

Printed copies of this document are not considered signed and sealed and the signature must be verified on any electronic copies.

**MOORE AND ASSOCIATES  
ENGINEERING AND CONSULTING, INC.**

**DRAWN BY: JG**

**CHECKED BY: PDH**

**PROJECT MGR: WSM**

**CLIENT: TBS**

**TUBULAR BUILDING SYSTEMS  
631 SE INDUSTRIAL CIRCLE  
LAKE CITY, FLORIDA 32025  
30'-0" x 20'-0" ENCLOSED BUILDING EXP. B**

**DATE: 7-29-21**

**SHT. 20**

**SCALE: NTS**

**DWG. NO: SK-3**

**JOB NO: 16022S/  
17300S/20352S**

**REV: 6**

THIS DOCUMENT IS THE PROPERTY OF MOORE AND ASSOCIATES ENGINEERING AND CONSULTING. THE UNAUTHORIZED REPRODUCTION, COPYING, OR OTHERWISE USE OF THIS DOCUMENT IS STRICTLY PROHIBITED AND ANY INFRINGEMENT THEREUPON MAY BE SUBJECT TO LEGAL ACTION.

# OPTIONAL CONCRETE STRIP FOOTING

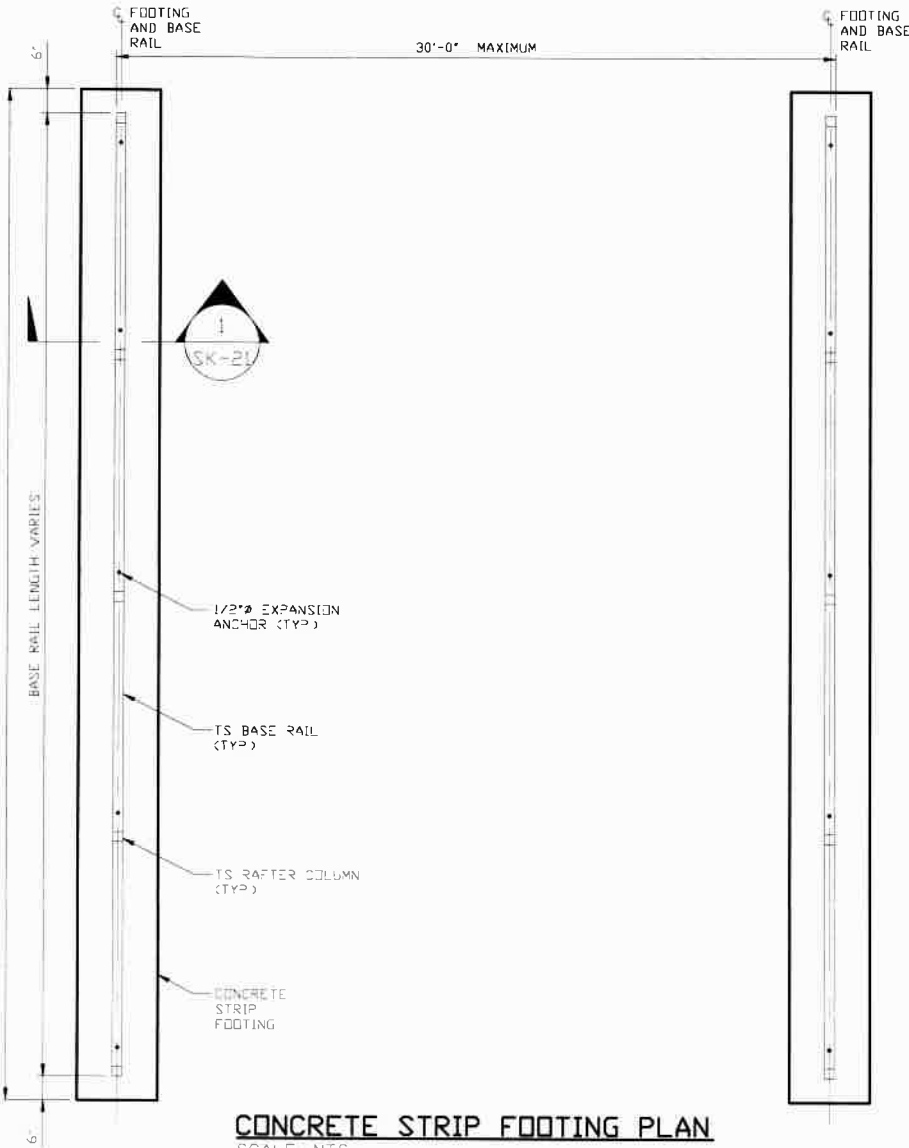

**CONCRETE STRIP FOOTING PLAN**  
SCALE: NTS

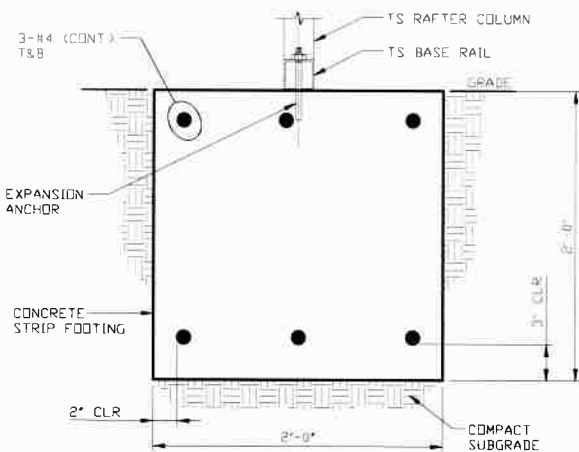

**SECTION 1**  
SCALE: NTS (SK-21)

\* COORDINATE WITH LOCAL CODES/ORD

- 1 STRIP FOOTING DESIGN BASED ON MINIMUM SOIL BEARING CAPACITY OF 1,500 PSF
- 2 CONCRETE SHALL HAVE A MINIMUM SPECIFIED COMPRESSIVE STRENGTH OF 3,000 PSI AT 28 DAYS
- 3 FOR FOUNDATIONS, MINIMUM CONCRETE COVER OVER REINFORCING BARS SHALL BE PER ACI-318: 3" IN FOUNDATIONS WHERE THE CONCRETE IS CAST AGAINST AND PERMANENTLY IN CONTACT WITH THE EARTH OR EXPOSED TO THE EARTH OR WEATHER, AND 1 1/2" ELSEWHERE
- 4 THE STRIP FOOTING REINFORCING STEEL SHALL BE ASTM A615 GRADE 60
- 5 REINFORCEMENT MAY BE BENT IN THE SHOP OR IN THE FIELD PROVIDED
  - A) REINFORCEMENT IS BENT COLD
  - B) THE DIAMETER OF THE BEND, MEASURED ON THE INSIDE OF THE BAR, IS NOT LESS THAN SIX-BAR DIAMETERS
  - C) REINFORCEMENT PARTIALLY EMBEDDED IN CONCRETE SHALL NOT BE FIELD BENT



This item has been electronically signed and sealed by Wayne S. Moore, PE, using a Digital Signature and date.

Printed copies of this document are not considered signed and sealed and the signature must be verified on any electronic copies.

**MOORE AND ASSOCIATES  
ENGINEERING AND CONSULTING, INC.**

**DRAWN BY:** JG

**CHECKED BY:** PDH

**PROJECT MGR:** WSM

**CLIENT:** TBS

**TUBULAR BUILDING SYSTEMS**  
631 SE INDUSTRIAL CIRCLE  
LAKE CITY, FLORIDA 32025  
30'-0"x20'-0" ENCLOSED BUILDING EXP. B

**DATE:** 7-29-21

**SHT.** 21

**SCALE:** NTS

**DWG. NO:** SK-3

**JOB NO:** 16022S/  
17300S/20352S

**REV.:** 6

THIS DOCUMENT IS THE PROPERTY OF MOORE AND ASSOCIATES ENGINEERING AND CONSULTING. THE UNAUTHORIZED REPRODUCTION, COPYING, OR OTHERWISE USE OF THIS DOCUMENT IS STRICTLY PROHIBITED AND ANY INFRINGEMENT THEREUPON MAY BE SUBJECT TO LEGAL ACTION.