



Lumber design values are in accordance with ANSI/TPI 1 section 6.3
These truss designs rely on lumber values established by others.

RE: 1398-A - Velo's Residence

MiTek, Inc.
16023 Swingley Ridge Rd.
Chesterfield, MO 63017
314.434.1200

Site Information:

Customer Info: Andres Velo Project Name: Velo Residence Model: .
Lot/Block: . Subdivision: .
Address: ., .
City: Ft. White State: FL

Name Address and License # of Structural Engineer of Record, If there is one, for the building.

Name: License #:
Address:
City: State:

General Truss Engineering Criteria & Design Loads (Individual Truss Design Drawings Show Special Loading Conditions):

Design Code: FBC2023/TPI2014 Design Program: MiTek 20/20 8.7
Wind Code: ASCE 7-22 Wind Speed: 130 mph
Roof Load: 40.0 psf Floor Load: N/A psf

This package includes 20 individual, Truss Design Drawings and 0 Additional Drawings.
With my seal affixed to this sheet, I hereby certify that I am the Truss Design Engineer and this index sheet conforms to 61G15-31.003, section 5 of the Florida Board of Professional Engineers Rules.

No.	Seal#	Truss Name	Date
1	T33229855	F1	3/14/24
2	T33229856	F2	3/14/24
3	T33229857	F3	3/14/24
4	T33229858	F4	3/14/24
5	T33229859	F5	3/14/24
6	T33229860	F6	3/14/24
7	T33229861	F7	3/14/24
8	T33229862	F8	3/14/24
9	T33229863	F10	3/14/24
10	T33229864	G1	3/14/24
11	T33229865	G2	3/14/24
12	T33229866	GA1	3/14/24
13	T33229867	GR1	3/14/24
14	T33229868	S1	3/14/24
15	T33229869	S2	3/14/24
16	T33229870	S3	3/14/24
17	T33229871	V1	3/14/24
18	T33229872	V2	3/14/24
19	T33229873	V3	3/14/24
20	T33229874	V4	3/14/24

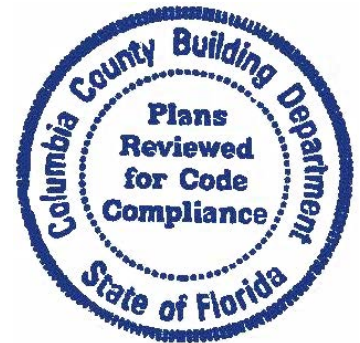

The truss drawing(s) referenced above have been prepared by MiTek USA, Inc. under my direct supervision based on the parameters provided by 19 Lumber, Inc..

Truss Design Engineer's Name: Lee, Julius
My license renewal date for the state of Florida is February 28, 2025.

IMPORTANT NOTE: The seal on these truss component designs is a certification that the engineer named is licensed in the jurisdiction(s) identified and that the designs comply with ANSI/TPI 1. These designs are based upon parameters shown (e.g., loads, supports, dimensions, shapes and design codes), which were given to MiTek or TRENCO. Any project specific information included is for MiTek's or TRENCO's customers file reference purpose only, and was not taken into account in the preparation of these designs. MiTek or TRENCO has not independently verified the applicability of the design parameters or the designs for any particular building. Before use, the building designer should verify applicability of design parameters and properly incorporate these designs into the overall building design per ANSI/TPI 1, Chapter 2.

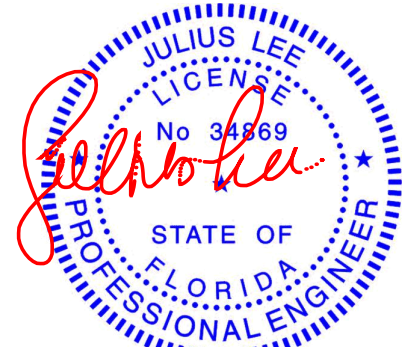

Julius Lee PE No. 34869
MiTek Inc. DBA MiTek USA FL Cert 6634
16023 Swingley Ridge Rd. Chesterfield, MO 63017
Date:

March 14, 2024

Job 1398-A	Truss F1	Truss Type Floor Supported Gable	Qty 1	Ply 1	Velo's Residence Job Reference (optional)	T33229855
---------------	-------------	-------------------------------------	----------	----------	--	-----------

19 Lumber, Inc., Old Town, FL - 32680,

Run: 8.73 S Feb 22 2024 Print: 8.730 S Feb 22 2024 MiTek Industries, Inc. Wed Mar 13 12:56:56

Page: 1

ID:VAvd_D0qrJ57MWtrgydTzdduw-RfC?PsB70Hq3NSgPqnL8w3uITXbGKWrcDoi7J4zJC?F

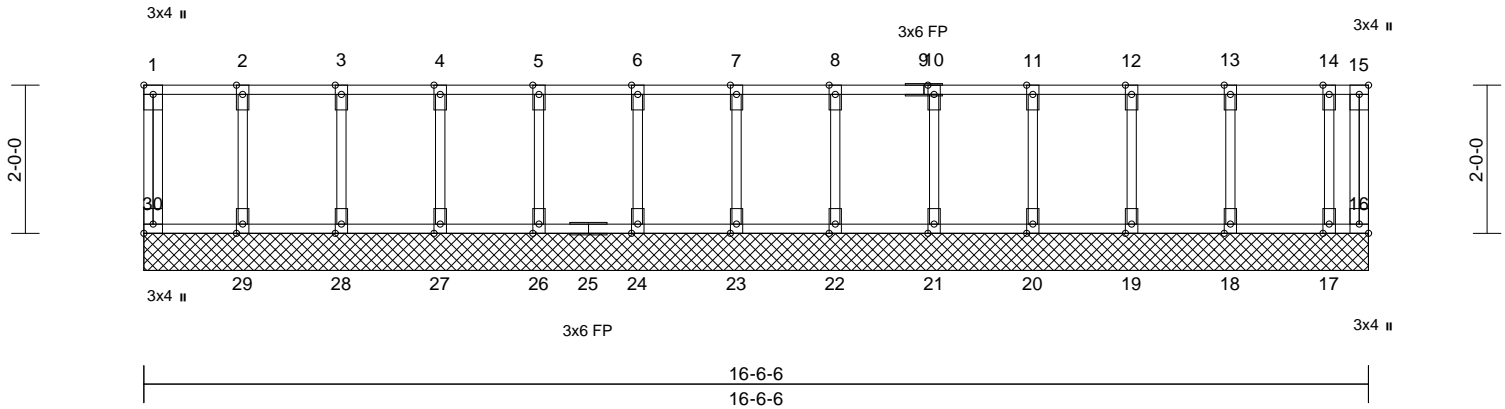

Scale = 1:31.1

Plate Offsets (X, Y): [1:Edge,0-1-8], [16:Edge,0-1-8], [30:Edge,0-1-8]

Loading	(psf)	Spacing	1-4-0	CSI	DEFL	in	(loc)	l/defl	L/d	PLATES	GRIP	
TCLL	40.0	Plate Grip DOL	1.00	TC	0.52	Vert(LL)	n/a	-	n/a	999	MT20	244/190
TCDL	10.0	Lumber DOL	1.00	BC	0.11	Vert(TL)	n/a	-	n/a	999		
BCLL	0.0	Rep Stress Incr	NO	WB	0.12	Horiz(TL)	0.00	16	n/a	n/a		
BCDL	5.0	Code	FBC2023/TPI2014	Matrix-AS							Weight: 91 lb	FT = 20%F, 11%E

LUMBER
TOP CHORD 2x4 SP No.2(flat)
BOT CHORD 2x4 SP No.2(flat)
WEBS 2x4 SP No.2(flat)
OTHERS 2x4 SP No.2(flat)

BRACING
TOP CHORD Structural wood sheathing directly applied, except end verticals.
BOT CHORD Rigid ceiling directly applied.

REACTIONS (size) 16=16-6-6, 17=16-6-6, 18=16-6-6, 19=16-6-6, 20=16-6-6, 21=16-6-6, 22=16-6-6, 23=16-6-6, 24=16-6-6, 26=16-6-6, 27=16-6-6, 28=16-6-6, 29=16-6-6, 30=16-6-6
Max Grav 16=80 (LC 1), 17=518 (LC 1), 18=813 (LC 1), 19=769 (LC 1), 20=780 (LC 1), 21=777 (LC 1), 22=778 (LC 1), 23=778 (LC 1), 24=778 (LC 1), 26=778 (LC 1), 27=777 (LC 1), 28=780 (LC 1), 29=776 (LC 1), 30=316 (LC 1)

FORCES (lb) - Maximum Compression/Maximum Tension
TOP CHORD 1-30=-315/0, 15-16=-28/0, 1-2=-22/0, 2-3=-22/0, 3-4=-22/0, 4-5=-22/0, 5-6=-22/0, 6-7=-22/0, 7-8=-22/0, 8-10=-22/0, 10-11=-22/0, 11-12=-22/0, 12-13=-22/0, 13-14=-22/0, 14-15=-22/0
BOT CHORD 29-30=0/22, 28-29=0/22, 27-28=0/22, 26-27=0/22, 24-26=0/22, 23-24=0/22, 22-23=0/22, 21-22=0/22, 20-21=0/22, 19-20=0/22, 18-19=0/22, 17-18=0/22, 16-17=0/22
WEBS 2-29=-765/0, 3-28=-772/0, 4-27=-768/0, 5-26=-769/0, 6-24=-769/0, 7-23=-769/0, 8-22=-769/0, 10-21=-768/0, 11-20=-771/0, 12-19=-761/0, 13-18=-801/0, 14-17=-564/0

NOTES

- Unbalanced floor live loads have been considered for this design.
- All plates are 2x4 MT20 unless otherwise indicated.
- Gable requires continuous bottom chord bearing.
- Truss to be fully sheathed from one face or securely braced against lateral movement (i.e. diagonal web).
- Gable studs spaced at 1-4-0 oc.
- All bearings are assumed to be SP No.2.
- This truss design requires that a minimum of 7/16" structural wood sheathing be applied directly to the top chord and 1/2" gypsum sheetrock be applied directly to the bottom chord.
- Recommend 2x6 strongbacks, on edge, spaced at 10-00-00 oc and fastened to each truss with 3-10d (0.131" X 3") nails. Strongbacks to be attached to walls at their outer ends or restrained by other means.
- In the LOAD CASE(S) section, loads applied to the face of the truss are noted as front (F) or back (B).

LOAD CASE(S) Standard
1) Dead + Floor Live (balanced): Lumber Increase=1.00, Plate Increase=1.00
Uniform Loads (lb/ft)
Vert: 16-30=-7, 1-15=-577 (F=-510)

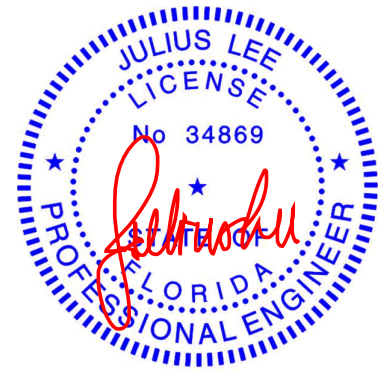

Julius Lee PE No. 34869
MiTek Inc. DBA MiTek USA FL Cert 6634
16023 Swingley Ridge Rd. Chesterfield, MO 63017
Date:

March 14, 2024

WARNING - Verify design parameters and READ NOTES ON THIS AND INCLUDED MITEK REFERENCE PAGE MII-7473 rev. 1/2/2023 BEFORE USE.

Design valid for use only with MiTek® connectors. This design is based only upon parameters shown, and is for an individual building component, not a truss system. Before use, the building designer must verify the applicability of design parameters and properly incorporate this design into the overall building design. Bracing indicated is to prevent buckling of individual truss web and/or chord members only. Additional temporary and permanent bracing is always required for stability and to prevent collapse with possible personal injury and property damage. For general guidance regarding the fabrication, storage, delivery, erection and bracing of trusses and truss systems, see **ANSI/TPI1 Quality Criteria and DSB-22** available from Truss Plate Institute (www.tpinst.org) and **BCSI Building Component Safety Information** available from the Structural Building Component Association (www.sbcsccomponents.com)

MiTek®

16023 Swingley Ridge Rd.
Chesterfield, MO 63017
314.434.1200 / MiTek-US.com

Job	Truss	Truss Type	Qty	Ply	Velo's Residence	T33229856
1398-A	F2	Floor	23	1	Job Reference (optional)	

19 Lumber, Inc., Old Town, FL - 32680,

Run: 8.73 S Feb 22 2024 Print: 8.730 S Feb 22 2024 MiTek Industries, Inc. Wed Mar 13 12:56:57
 ID:zNT?BZ0ScyRjIw53PNTs?7zdduv-RfC?PsB70Hq3NSgPqnL8w3uITXbGKWrCDoi7J4zJC?f

Page: 1

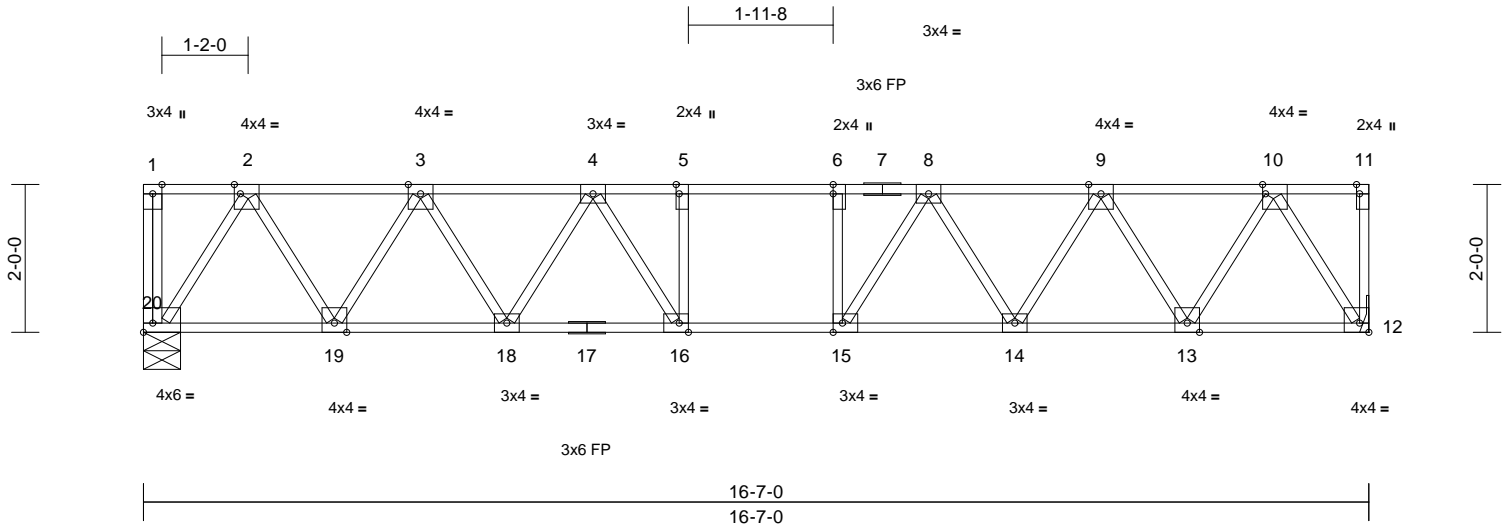

Scale = 1:31.2

Plate Offsets (X, Y): [2:0-1-0,Edge], [5:0-1-8,Edge], [6:0-1-8,Edge], [10:0-0-8,Edge], [11:0-1-8,Edge], [12:Edge,0-1-8], [15:0-1-8,Edge], [16:0-1-8,Edge], [20:Edge,0-1-8]

Loading	(psf)	Spacing	1-4-0	CSI	DEFL	in	(loc)	l/defl	L/d	PLATES	GRIP	
TCLL	40.0	Plate Grip DOL	1.00	TC	0.39	Vert(LL)	-0.08	16-18	>999	360	MT20	244/190
TCDL	10.0	Lumber DOL	1.00	BC	0.46	Vert(CT)	-0.10	16-18	>999	240		
BCLL	0.0	Rep Stress Incr	YES	WB	0.15	Horz(CT)	0.02	12	n/a	n/a		
BCDL	5.0	Code	FBC2023/TPI2014	Matrix-AS							Weight: 98 lb	FT = 20%F, 11%E

LUMBER

TOP CHORD 2x4 SP No.2(flat)
 BOT CHORD 2x4 SP No.2(flat)
 WEBS 2x4 SP No.2(flat)

BRACING

TOP CHORD Structural wood sheathing directly applied, except end verticals.
 BOT CHORD Rigid ceiling directly applied.

REACTIONS (size) 12= Mechanical, 20=0-6-0
 Max Grav 12=601 (LC 1), 20=601 (LC 1)

FORCES (lb) - Maximum Compression/Maximum Tension

TOP CHORD 1-20=-26/0, 11-12=-23/0, 1-2=0/0,
 2-3=-662/0, 3-4=-1077/0, 4-5=-1299/0,
 5-6=-1302/0, 6-8=-1298/0, 8-9=-1069/0,
 9-10=-648/0, 10-11=0/0

BOT CHORD 19-20=0/391, 18-19=0/922, 16-18=0/1224,
 15-16=0/1302, 14-15=0/1218, 13-14=0/910,
 12-13=0/374

WEBS 10-12=-683/0, 2-20=-690/0, 10-13=0/518,
 2-19=0/512, 9-13=-497/0, 3-19=-491/0,
 9-14=0/300, 3-18=0/295, 8-14=-283/0,
 4-18=-277/0, 8-15=-32/310, 4-16=-39/303,
 5-16=-193/0, 6-15=-197/0

NOTES

- 1) Unbalanced floor live loads have been considered for this design.
- 2) Bearings are assumed to be: Joint 20 SP No.2 .
- 3) Refer to girder(s) for truss to truss connections.
- 4) This truss design requires that a minimum of 7/16" structural wood sheathing be applied directly to the top chord and 1/2" gypsum sheetrock be applied directly to the bottom chord.
- 5) Recommend 2x6 strongbacks, on edge, spaced at 10-00-00 oc and fastened to each truss with 3-10d (0.131" X 3") nails. Strongbacks to be attached to walls at their outer ends or restrained by other means.

LOAD CASE(S) Standard

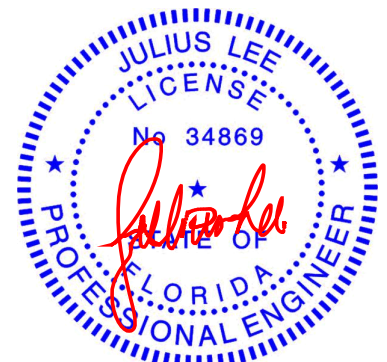

Julius Lee PE No. 34869
 MiTek Inc. DBA MiTek USA FL Cert 6634
 16023 Swingley Ridge Rd. Chesterfield, MO 63017
 Date:

March 14, 2024

WARNING - Verify design parameters and READ NOTES ON THIS AND INCLUDED MITEK REFERENCE PAGE MII-7473 rev. 1/2/2023 BEFORE USE.

Design valid for use only with MiTek® connectors. This design is based only upon parameters shown, and is for an individual building component, not a truss system. Before use, the building designer must verify the applicability of design parameters and properly incorporate this design into the overall building design. Bracing indicated is to prevent buckling of individual truss web and/or chord members only. Additional temporary and permanent bracing is always required for stability and to prevent collapse with possible personal injury and property damage. For general guidance regarding the fabrication, storage, delivery, erection and bracing of trusses and truss systems, see **ANSI/TPI1 Quality Criteria and DSB-22** available from Truss Plate Institute (www.tpinst.org) and **BCSI Building Component Safety Information** available from the Structural Building Component Association (www.sbcsccomponents.com)

MiTek®

16023 Swingley Ridge Rd.
 Chesterfield, MO 63017
 314.434.1200 / MiTek-US.com

Job 1398-A	Truss F3	Truss Type Floor Supported Gable	Qty 1	Ply 1	Velo's Residence Job Reference (optional)	T33229857
---------------	-------------	-------------------------------------	----------	----------	--	-----------

19 Lumber, Inc., Old Town, FL - 32680,

Run: 8.73 S Feb 22 2024 Print: 8.730 S Feb 22 2024 MiTek Industries, Inc. Wed Mar 13 12:56:57
ID:zNT?BZ0ScyRjIW53PNTs?7zdduv-RfC?PsB70Hq3NSgPqnL8w3uITXbGKWrCDoi7J4zJC7f

Page: 1

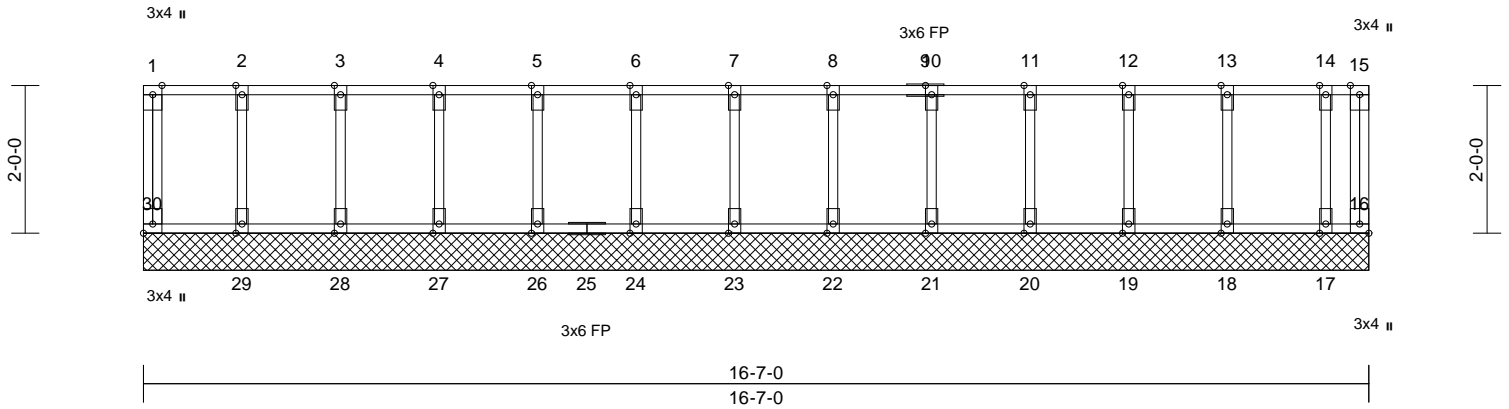

Scale = 1:31.2

Plate Offsets (X, Y): [10:Edge,0-1-0], [16:Edge,0-1-8], [30:Edge,0-1-8]

Loading	(psf)	Spacing	1-4-0	CSI	DEFL	in	(loc)	l/defl	L/d	PLATES	GRIP	
TCLL	40.0	Plate Grip DOL	1.00	TC	0.52	Vert(LL)	n/a	-	n/a	999	MT20	244/190
TCDL	10.0	Lumber DOL	1.00	BC	0.11	Vert(TL)	n/a	-	n/a	999		
BCLL	0.0	Rep Stress Incr	NO	WB	0.12	Horiz(TL)	0.00	16	n/a	n/a		
BCDL	5.0	Code	FBC2023/TPI2014	Matrix-AS							Weight: 91 lb	FT = 20%F, 11%E

LUMBER
TOP CHORD 2x4 SP No.2(flat)
BOT CHORD 2x4 SP No.2(flat)
WEBS 2x4 SP No.2(flat)
OTHERS 2x4 SP No.2(flat)

BRACING
TOP CHORD Structural wood sheathing directly applied, except end verticals.
BOT CHORD Rigid ceiling directly applied.

REACTIONS (size) 16=16-7-0, 17=16-7-0, 18=16-7-0, 19=16-7-0, 20=16-7-0, 21=16-7-0, 22=16-7-0, 23=16-7-0, 24=16-7-0, 26=16-7-0, 27=16-7-0, 28=16-7-0, 29=16-7-0, 30=16-7-0
Max Grav 16=97 (LC 1), 17=531 (LC 1), 18=813 (LC 1), 19=769 (LC 1), 20=780 (LC 1), 21=777 (LC 1), 22=778 (LC 1), 23=778 (LC 1), 24=778 (LC 1), 26=778 (LC 1), 27=777 (LC 1), 28=779 (LC 1), 29=778 (LC 1), 30=314 (LC 1)

FORCES (lb) - Maximum Compression/Maximum Tension
TOP CHORD 1-30=-314/0, 15-16=-51/0, 1-2=-21/0, 2-3=-21/0, 3-4=-21/0, 4-5=-21/0, 5-6=-21/0, 6-7=-21/0, 7-8=-21/0, 8-10=-21/0, 10-11=-21/0, 11-12=-21/0, 12-13=-21/0, 13-14=-21/0, 14-15=-21/0
BOT CHORD 29-30=0/21, 28-29=0/21, 27-28=0/21, 26-27=0/21, 24-26=0/21, 23-24=0/21, 22-23=0/21, 21-22=0/21, 20-21=0/21, 19-20=0/21, 18-19=0/21, 17-18=0/21, 16-17=0/21
WEBS 2-29=-765/0, 3-28=-771/0, 4-27=-768/0, 5-26=-769/0, 6-24=-769/0, 7-23=-769/0, 8-22=-769/0, 10-21=-768/0, 11-20=-771/0, 12-19=-761/0, 13-18=-801/0, 14-17=-572/0

NOTES

- Unbalanced floor live loads have been considered for this design.
- All plates are 2x4 MT20 unless otherwise indicated.
- Gable requires continuous bottom chord bearing.
- Truss to be fully sheathed from one face or securely braced against lateral movement (i.e. diagonal web).
- Gable studs spaced at 1-4-0 oc.
- All bearings are assumed to be SP No.2 .
- This truss design requires that a minimum of 7/16" structural wood sheathing be applied directly to the top chord and 1/2" gypsum sheetrock be applied directly to the bottom chord.
- Recommend 2x6 strongbacks, on edge, spaced at 10-00-00 oc and fastened to each truss with 3-10d (0.131" X 3") nails. Strongbacks to be attached to walls at their outer ends or restrained by other means.
- In the LOAD CASE(S) section, loads applied to the face of the truss are noted as front (F) or back (B).

LOAD CASE(S) Standard
1) Dead + Floor Live (balanced): Lumber Increase=1.00, Plate Increase=1.00
Uniform Loads (lb/ft)
Vert: 16-30=-7, 1-15=-577 (F=-510)



Julius Lee PE No. 34869
MiTek Inc. DBA MiTek USA FL Cert 6634
16023 Swingley Ridge Rd. Chesterfield, MO 63017
Date:

March 14, 2024

WARNING - Verify design parameters and READ NOTES ON THIS AND INCLUDED MITEK REFERENCE PAGE MII-7473 rev. 1/2/2023 BEFORE USE.

Design valid for use only with MiTek® connectors. This design is based only upon parameters shown, and is for an individual building component, not a truss system. Before use, the building designer must verify the applicability of design parameters and properly incorporate this design into the overall building design. Bracing indicated is to prevent buckling of individual truss web and/or chord members only. Additional temporary and permanent bracing is always required for stability and to prevent collapse with possible personal injury and property damage. For general guidance regarding the fabrication, storage, delivery, erection and bracing of trusses and truss systems, see **ANSI/TPI1 Quality Criteria and DSB-22** available from Truss Plate Institute (www.tpinst.org) and **BCSI Building Component Safety Information** available from the Structural Building Component Association (www.sbcsccomponents.com)

MiTek®

16023 Swingley Ridge Rd.
Chesterfield, MO 63017
314.434.1200 / MiTek-US.com

Job 1398-A	Truss F4	Truss Type Floor Girder	Qty 1	Ply 2	Velo's Residence Job Reference (optional)	T33229858
---------------	-------------	----------------------------	----------	----------	--	-----------

19 Lumber, Inc., Old Town, FL - 32680,

Run: 8.73 S Feb 22 2024 Print: 8.730 S Feb 22 2024 MiTek Industries, Inc. Wed Mar 13 12:56:57
ID:tcX69z5E?7scZTn1VbxHdzdeVY-RfC?PsB70Hq3NSgPqnL8w3uITXbGKWrCDoi7J4zJC7f

Page: 1

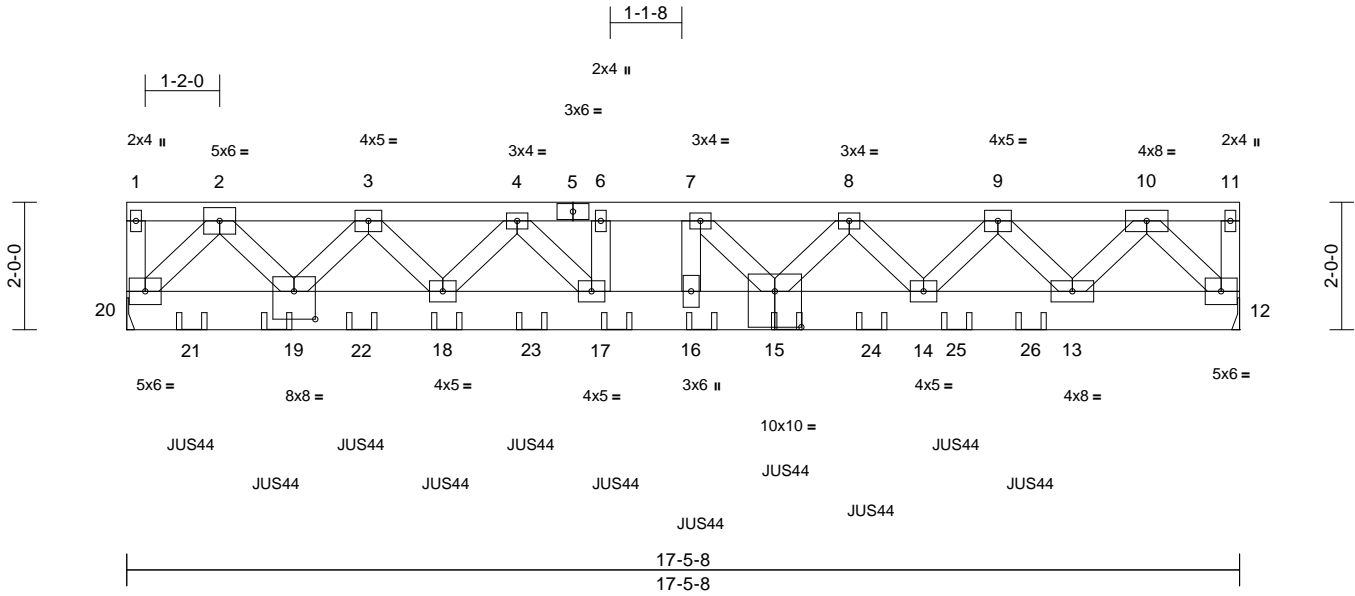

Scale = 1:36.1

Plate Offsets (X, Y): [15:0-5-0,0-6-12], [19:0-4-0,0-5-4]

Loading	(psf)	Spacing	1-4-0	CSI	DEFL	in	(loc)	l/defl	L/d	PLATES	GRIP
TCLL	40.0	Plate Grip DOL	1.00	TC	0.84	Vert(LL)	-0.23	16	>910	360	MT20 244/190
TCDL	10.0	Lumber DOL	1.00	BC	0.54	Vert(CT)	-0.31	16	>666	240	
BCLL	0.0	Rep Stress Incr	NO	WB	0.67	Horz(CT)	0.04	12	n/a	n/a	
BCDL	5.0	Code	FBC2023/TPI2014	Matrix-MS							Weight: 235 lb FT = 11%

LUMBER

TOP CHORD 2x4 SP No.2
BOT CHORD 2x8 SP DSS
WEBS 2x4 SP No.2

BRACING

TOP CHORD Structural wood sheathing directly applied or 2-4-11 oc purlins, except end verticals.
BOT CHORD Rigid ceiling directly applied or 10-0-0 oc bracing.

REACTIONS (size) 12= Mechanical, 20= Mechanical
Max Grav 12=3721 (LC 1), 20=4623 (LC 1)

FORCES (lb) - Maximum Compression/Maximum Tension

TOP CHORD 1-20=-106/0, 11-12=-92/0, 1-2=-116/0, 2-3=-6246/0, 3-4=-10155/0, 4-6=-12195/0, 6-7=-12195/0, 7-8=-11674/0, 8-9=-9667/0, 9-10=-5518/0, 10-11=-89/0
BOT CHORD 19-20=0/3389, 18-19=0/8254, 17-18=0/11188, 16-17=0/12195, 14-16=0/12195, 13-14=0/7651, 12-13=0/2996

WEBS 10-12=-4502/0, 2-20=-5068/0, 10-13=0/4199, 2-19=0/4755, 9-13=-3550/0, 3-19=-3343/0, 9-14=0/3355, 3-18=0/3163, 8-14=-1771/0, 4-18=-1720/0, 8-15=0/1644, 4-17=0/1670, 7-15=-926/0, 6-17=-2/6, 7-16=0/617

NOTES

- 2-ply truss to be connected together with 10d (0.131"x3") nails as follows:
Top chords connected as follows: 2x4 - 1 row at 0-6-0 oc.
Bottom chords connected as follows: 2x8 - 2 rows staggered at 0-9-0 oc.
Web connected as follows: 2x4 - 1 row at 0-9-0 oc.

- All loads are considered equally applied to all plies, except if noted as front (F) or back (B) face in the LOAD CASE(S) section. Ply to ply connections have been provided to distribute only loads noted as (F) or (B), unless otherwise indicated.
- Unbalanced floor live loads have been considered for this design.
- The Fabrication Tolerance at joint 5 = 11%
- Refer to girder(s) for truss to truss connections.
- Recommend 2x6 strongbacks, on edge, spaced at 10-00-00 oc and fastened to each truss with 3-10d (0.131" X 3") nails. Strongbacks to be attached to walls at their outer ends or restrained by other means.
- Use MiTek JUS44 (With 4-16d nails into Girder & 2-16d nails into Truss) or equivalent spaced at 1-4-0 oc max. starting at 1-0-4 from the left end to 14-2-4 to connect truss(es) to front face of bottom chord.
- Fill all nail holes where hanger is in contact with lumber.

LOAD CASE(S) Standard

- Dead + Floor Live (balanced): Lumber Increase=1.00, Plate Increase=1.00
Uniform Loads (lb/ft)
Vert: 12-20=-7, 1-11=-67
Concentrated Loads (lb)
Vert: 15=-644 (F), 19=-644 (F), 18=-644 (F), 17=-644 (F), 16=-644 (F), 21=-644 (F), 22=-644 (F), 23=-644 (F), 24=-644 (F), 25=-644 (F), 26=-644 (F)

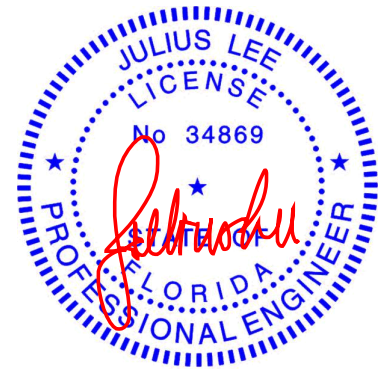

Julius Lee PE No. 34869
MiTek Inc. DBA MiTek USA FL Cert 6634
16023 Swingley Ridge Rd. Chesterfield, MO 63017
Date:

March 14, 2024

WARNING - Verify design parameters and READ NOTES ON THIS AND INCLUDED MITEK REFERENCE PAGE MII-7473 rev. 1/2/2023 BEFORE USE.

Design valid for use only with MiTek® connectors. This design is based only upon parameters shown, and is for an individual building component, not a truss system. Before use, the building designer must verify the applicability of this design into the overall building design. Bracing indicated is to prevent buckling of individual truss web and/or chord members only. Additional temporary and permanent bracing is always required for stability and to prevent collapse with possible personal injury and property damage. For general guidance regarding the fabrication, storage, delivery, erection and bracing of trusses and truss systems, see **ANSI/TPI1 Quality Criteria and DSB-22** available from Truss Plate Institute (www.tpinst.org) and **BCSI Building Component Safety Information** available from the Structural Building Component Association (www.sbcsccomponents.com)

MiTek®

16023 Swingley Ridge Rd.
Chesterfield, MO 63017
314.434.1200 / MiTek-US.com

Job 1398-A	Truss F5	Truss Type Floor Supported Gable	Qty 2	Ply 1	Velo's Residence Job Reference (optional)	T33229859
---------------	-------------	-------------------------------------	----------	----------	--	-----------

19 Lumber, Inc., Old Town, FL - 32680,

Run: 8.73 S Feb 22 2024 Print: 8.730 S Feb 22 2024 MiTek Industries, Inc. Wed Mar 13 12:56:57
ID:zNT?BZ0ScyRjIW53PNTs?7zdduv-RfC?PsB70Hq3NSgPqnL8w3uITXbGKWrCDoi7J4zJC?f

Page: 1

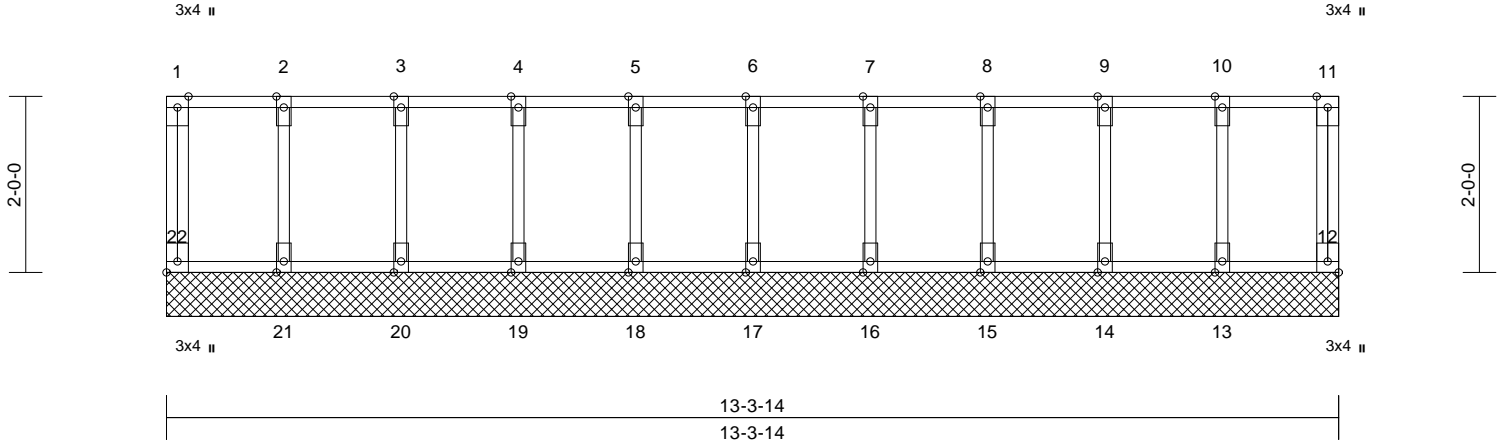

Scale = 1:26.2

Plate Offsets (X, Y): [12:Edge,0-1-8], [22:Edge,0-1-8]

Loading	(psf)	Spacing	1-4-0	CSI	DEFL	in	(loc)	l/defl	L/d	PLATES	GRIP	
TCLL	40.0	Plate Grip DOL	1.00	TC	0.49	Vert(LL)	n/a	-	n/a	999	MT20	244/190
TCDL	10.0	Lumber DOL	1.00	BC	0.05	Vert(TL)	n/a	-	n/a	999		
BCLL	0.0	Rep Stress Incr	NO	WB	0.11	Horiz(TL)	0.00	12	n/a	n/a		
BCDL	5.0	Code	FBC2023/TPI2014	Matrix-AS							Weight: 73 lb	FT = 20%F, 11%E

LUMBER

TOP CHORD 2x4 SP No.2(flat)
 BOT CHORD 2x4 SP No.2(flat)
 WEBS 2x4 SP No.2(flat)
 OTHERS 2x4 SP No.2(flat)

BRACING

TOP CHORD Structural wood sheathing directly applied, except end verticals.
 BOT CHORD Rigid ceiling directly applied.

REACTIONS

(size) 12=13-3-14, 13=13-3-14, 14=13-3-14, 15=13-3-14, 16=13-3-14, 17=13-3-14, 18=13-3-14, 19=13-3-14, 20=13-3-14, 21=13-3-14, 22=13-3-14
 Max Grav 12=331 (LC 1), 13=750 (LC 1), 14=786 (LC 1), 15=776 (LC 1), 16=778 (LC 1), 17=778 (LC 1), 18=778 (LC 1), 19=776 (LC 1), 20=785 (LC 1), 21=755 (LC 1), 22=333 (LC 1)

FORCES

(lb) - Maximum Compression/Maximum Tension

TOP CHORD 1-22=-323/0, 11-12=-320/0, 1-2=-31/0, 2-3=-31/0, 3-4=-31/0, 4-5=-31/0, 5-6=-31/0, 6-7=-31/0, 7-8=-31/0, 8-9=-31/0, 9-10=-31/0, 10-11=-31/0
 BOT CHORD 21-22=0/31, 20-21=0/31, 19-20=0/31, 18-19=0/31, 17-18=0/31, 16-17=0/31, 15-16=0/31, 14-15=0/31, 13-14=0/31, 12-13=0/31
 WEBS 2-21=-754/0, 3-20=-774/0, 4-19=-768/0, 5-18=-769/0, 6-17=-769/0, 7-16=-769/0, 8-15=-767/0, 9-14=-775/0, 10-13=-750/0

NOTES

- Unbalanced floor live loads have been considered for this design.
- All plates are 2x4 MT20 unless otherwise indicated.

- Gable requires continuous bottom chord bearing.
- Truss to be fully sheathed from one face or securely braced against lateral movement (i.e. diagonal web).
- Gable studs spaced at 1-4-0 oc.
- All bearings are assumed to be SP No.2 .
- This truss design requires that a minimum of 7/16" structural wood sheathing be applied directly to the top chord and 1/2" gypsum sheetrock be applied directly to the bottom chord.
- Recommend 2x6 strongbacks, on edge, spaced at 10-00-00 oc and fastened to each truss with 3-10d (0.131" X 3") nails. Strongbacks to be attached to walls at their outer ends or restrained by other means.
- In the LOAD CASE(S) section, loads applied to the face of the truss are noted as front (F) or back (B).

LOAD CASE(S) Standard

- Dead + Floor Live (balanced): Lumber Increase=1.00, Plate Increase=1.00
 Uniform Loads (lb/ft)
 Vert: 12-22=-7, 1-11=-577 (F=-510)

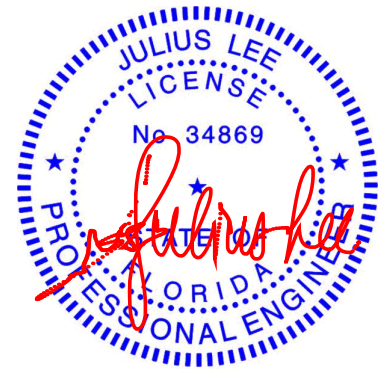

Julius Lee PE No. 34869
 MiTek Inc. DBA MiTek USA FL Cert 6634
 16023 Swingley Ridge Rd. Chesterfield, MO 63017
 Date:

March 14, 2024

WARNING - Verify design parameters and READ NOTES ON THIS AND INCLUDED MITEK REFERENCE PAGE MII-7473 rev. 1/2/2023 BEFORE USE.

Design valid for use only with MiTek® connectors. This design is based only upon parameters shown, and is for an individual building component, not a truss system. Before use, the building designer must verify the applicability of design parameters and properly incorporate this design into the overall building design. Bracing indicated is to prevent buckling of individual truss web and/or chord members only. Additional temporary and permanent bracing is always required for stability and to prevent collapse with possible personal injury and property damage. For general guidance regarding the fabrication, storage, delivery, erection and bracing of trusses and truss systems, see **ANSI/TPI1 Quality Criteria and DSB-22** available from Truss Plate Institute (www.tpinst.org) and **BCSI Building Component Safety Information** available from the Structural Building Component Association (www.sbcsccomponents.com)

MiTek®

16023 Swingley Ridge Rd.
 Chesterfield, MO 63017
 314.434.1200 / MiTek-US.com

Job 1398-A	Truss F6	Truss Type Floor	Qty 11	Ply 1	Velo's Residence Job Reference (optional)	T33229860
---------------	-------------	---------------------	-----------	----------	--	-----------

19 Lumber, Inc., Old Town, FL - 32680,

Run: 8.73 S Nov 16 2023 Print: 8.730 S Nov 16 2023 MiTek Industries, Inc. Thu Mar 14 15:02:36
ID:tcX69z5E?7scZTXn1VbxHdzdeVY-wuSJ0?tJhpgCZZ2vd02tJ8d_??oqRDccWAYomzb?Co

Page: 1

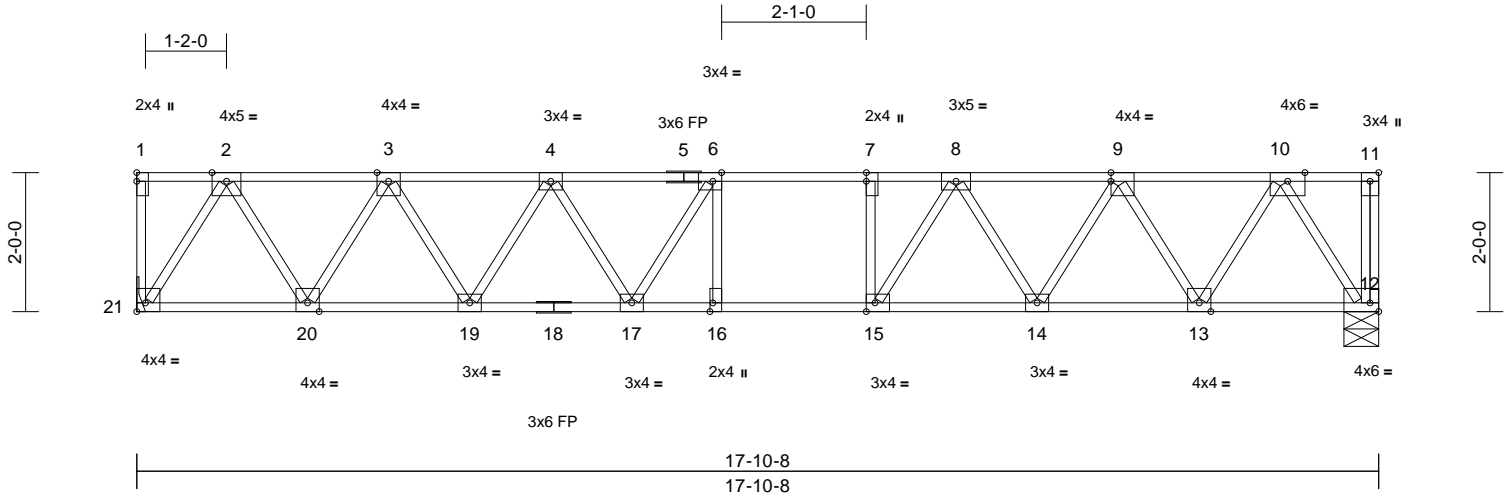

Scale = 1:33.2

Plate Offsets (X, Y): [6:0-1-8,Edge], [7:0-1-8,Edge], [9:0-0-0,Edge], [12:Edge,0-1-8], [15:0-1-8,Edge], [16:0-1-8,Edge], [21:Edge,0-1-8]

Loading	(psf)	Spacing	1-4-0	CSI	DEFL	in (loc)	l/defl	L/d	PLATES	GRIP		
TCLL	40.0	Plate Grip DOL	1.00	TC	0.53	Vert(LL)	-0.12	16-17	>999	360	MT20	244/190
TCDL	10.0	Lumber DOL	1.00	BC	0.75	Vert(CT)	-0.16	16-17	>999	240		
BCLL	0.0	Rep Stress Incr	YES	WB	0.16	Horz(CT)	0.03	12	n/a	n/a		
BCDL	5.0	Code	FBC2023/TPI2014	Matrix-AS							Weight: 105 lb	FT = 20%F, 11%E

LUMBER

TOP CHORD 2x4 SP No.2(flat)
 BOT CHORD 2x4 SP No.2(flat)
 WEBS 2x4 SP No.2(flat)

BRACING

TOP CHORD Structural wood sheathing directly applied, except end verticals.
 BOT CHORD Rigid ceiling directly applied.

REACTIONS (lb/size) 12=649/0-6-0, 21=649/ Mechanical

FORCES (lb) - Max. Comp./Max. Ten. - All forces 250 (lb) or less except when shown.

TOP CHORD 2-3=-708/0, 3-4=-1191/0, 4-5=-1456/0, 5-6=-1456/0, 6-7=-1511/0, 7-8=-1506/0, 8-9=-1194/0, 9-10=-725/0

BOT CHORD 20-21=0/406, 19-20=0/998, 18-19=0/1376, 17-18=0/1376, 16-17=0/1512, 15-16=0/1511, 14-15=0/1375, 13-14=0/1013, 12-13=0/424

WEBS 10-12=-748/0, 2-21=-741/0, 10-13=0/570, 2-20=0/571, 9-13=-544/0, 3-20=-549/0, 9-14=0/343, 3-19=0/365, 8-14=-344/0, 4-19=-351/0, 8-15=0/397, 6-17=-270/67

NOTES

- Unbalanced floor live loads have been considered for this design.
- Refer to girder(s) for truss to truss connections.
- This truss design requires that a minimum of 7/16" structural wood sheathing be applied directly to the top chord and 1/2" gypsum sheetrock be applied directly to the bottom chord.
- Recommend 2x6 strongbacks, on edge, spaced at 10-00-00 oc and fastened to each truss with 3-10d (0.131" X 3") nails. Strongbacks to be attached to walls at their outer ends or restrained by other means.

LOAD CASE(S) Standard



Julius Lee PE No. 34869
 MiTek Inc. DBA MiTek USA FL Cert 6634
 16023 Swingley Ridge Rd. Chesterfield, MO 63017
 Date:

March 14, 2024

WARNING - Verify design parameters and READ NOTES ON THIS AND INCLUDED MITEK REFERENCE PAGE MII-7473 rev. 1/2/2023 BEFORE USE.

Design valid for use only with MiTek® connectors. This design is based only upon parameters shown, and is for an individual building component, not a truss system. Before use, the building designer must verify the applicability of design parameters and properly incorporate this design into the overall building design. Bracing indicated is to prevent buckling of individual truss web and/or chord members only. Additional temporary and permanent bracing is always required for stability and to prevent collapse with possible personal injury and property damage. For general guidance regarding the fabrication, storage, delivery, erection and bracing of trusses and truss systems, see **ANSI/TPI1 Quality Criteria and DSB-22** available from Truss Plate Institute (www.tpinst.org) and **BCSI Building Component Safety Information** available from the Structural Building Component Association (www.sbcsccomponents.com)

MiTek®

16023 Swingley Ridge Rd.
 Chesterfield, MO 63017
 314.434.1200 / MiTek-US.com

Job 1398-A	Truss F7	Truss Type Floor	Qty 11	Ply 1	Velo's Residence Job Reference (optional)	T33229861
---------------	-------------	---------------------	-----------	----------	--	-----------

19 Lumber, Inc., Old Town, FL - 32680,

Run: 8.73 S Feb 22 2024 Print: 8.730 S Feb 22 2024 MiTek Industries, Inc. Wed Mar 13 12:56:57
ID:zNT?BZ0ScyRjIw53PNTs?7zdduv-RfC?PsB70Hq3NSgPqnL8w3uITxbGKWrCdoi7J4zJC?f

Page: 1

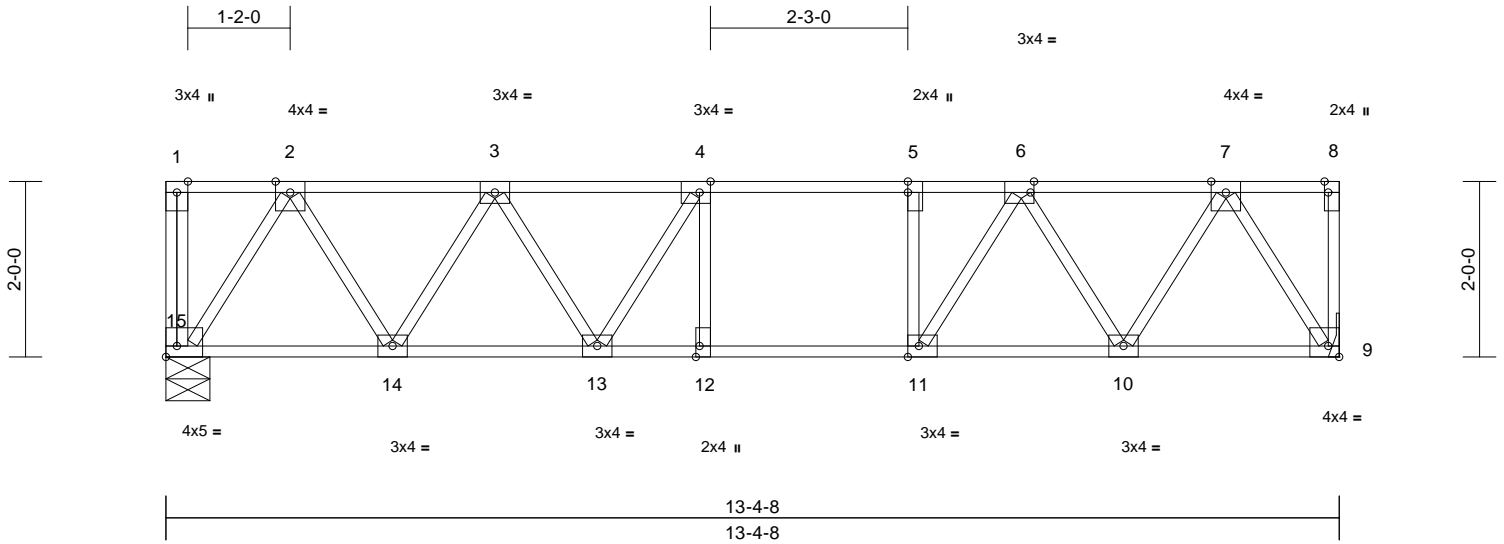

Scale = 1:26.3

Plate Offsets (X, Y): [4:0-1-8,Edge], [5:0-1-8,Edge], [6:0-0-8,Edge], [8:0-1-8,Edge], [9:Edge,0-1-8], [11:0-1-8,Edge], [12:0-1-8,Edge], [15:Edge,0-1-8]

Loading	(psf)	Spacing	1-4-0	CSI	DEFL	in	(loc)	l/defl	L/d	PLATES	GRIP	
TCLL	40.0	Plate Grip DOL	1.00	TC	0.48	Vert(LL)	-0.08	12-13	>999	360	MT20	244/190
TCDL	10.0	Lumber DOL	1.00	BC	0.55	Vert(CT)	-0.10	12-13	>999	240		
BCLL	0.0	Rep Stress Incr	YES	WB	0.11	Horz(CT)	0.01	9	n/a	n/a		
BCDL	5.0	Code	FBC2023/TPI2014	Matrix-AS							Weight: 79 lb	FT = 20%F, 11%E

LUMBER

TOP CHORD 2x4 SP No.2(flat)
BOT CHORD 2x4 SP No.2(flat)
WEBS 2x4 SP No.2(flat)

BRACING

TOP CHORD Structural wood sheathing directly applied, except end verticals.
BOT CHORD Rigid ceiling directly applied.

REACTIONS (size) 9= Mechanical, 15=0-6-0
Max Grav 9=484 (LC 1), 15=484 (LC 1)

FORCES (lb) - Maximum Compression/Maximum Tension

TOP CHORD 1-15=-29/0, 8-9=-21/0, 1-2=0/0, 2-3=-508/0, 3-4=-777/0, 4-5=-829/0, 5-6=-824/0, 6-7=-491/0, 7-8=0/0

BOT CHORD 14-15=0/309, 13-14=0/697, 12-13=0/830, 11-12=0/829, 10-11=0/682, 9-10=0/299

WEBS 7-9=-545/0, 2-15=-546/0, 7-10=0/363, 2-14=0/376, 6-10=-362/0, 3-14=-358/0, 6-11=0/354, 3-13=0/193, 4-13=-205/5, 4-12=-92/45, 5-11=-211/0

NOTES

- Unbalanced floor live loads have been considered for this design.
- Bearings are assumed to be: Joint 15 SP No.2 .
- Refer to girder(s) for truss to truss connections.
- This truss design requires that a minimum of 7/16" structural wood sheathing be applied directly to the top chord and 1/2" gypsum sheetrock be applied directly to the bottom chord.
- Recommend 2x6 strongbacks, on edge, spaced at 10-00-00 oc and fastened to each truss with 3-10d (0.131" X 3") nails. Strongbacks to be attached to walls at their outer ends or restrained by other means.

LOAD CASE(S) Standard



Julius Lee PE No. 34869
MiTek Inc. DBA MiTek USA FL Cert 6634
16023 Swingley Ridge Rd. Chesterfield, MO 63017
Date:

March 14, 2024

WARNING - Verify design parameters and READ NOTES ON THIS AND INCLUDED MITEK REFERENCE PAGE MII-7473 rev. 1/2/2023 BEFORE USE.

Design valid for use only with MiTek® connectors. This design is based only upon parameters shown, and is for an individual building component, not a truss system. Before use, the building designer must verify the applicability of the design parameters and properly incorporate this design into the overall building design. Bracing indicated is to prevent buckling of individual truss web and/or chord members only. Additional temporary and permanent bracing is always required for stability and to prevent collapse with possible personal injury and property damage. For general guidance regarding the fabrication, storage, delivery, erection and bracing of trusses and truss systems, see **ANSI/TPI1 Quality Criteria and DSB-22** available from Truss Plate Institute (www.tpinst.org) and **BCSI Building Component Safety Information** available from the Structural Building Component Association (www.sbcsccomponents.com)

MiTek®

16023 Swingley Ridge Rd.
Chesterfield, MO 63017
314.434.1200 / MiTek-US.com

Job 1398-A	Truss F8	Truss Type Floor	Qty 12	Ply 1	Velo's Residence Job Reference (optional)	T33229862
---------------	-------------	---------------------	-----------	----------	--	-----------

19 Lumber, Inc., Old Town, FL - 32680,

Run: 8.73 S Feb 22 2024 Print: 8.730 S Feb 22 2024 MiTek Industries, Inc. Wed Mar 13 12:56:58
ID:zNT?BZ0ScyRjIw53PNTs?7zdduv-RfC?PsB70Hq3NSgPqnL8w3uITxBGKWrCDoi7J4zJC7f

Page: 1

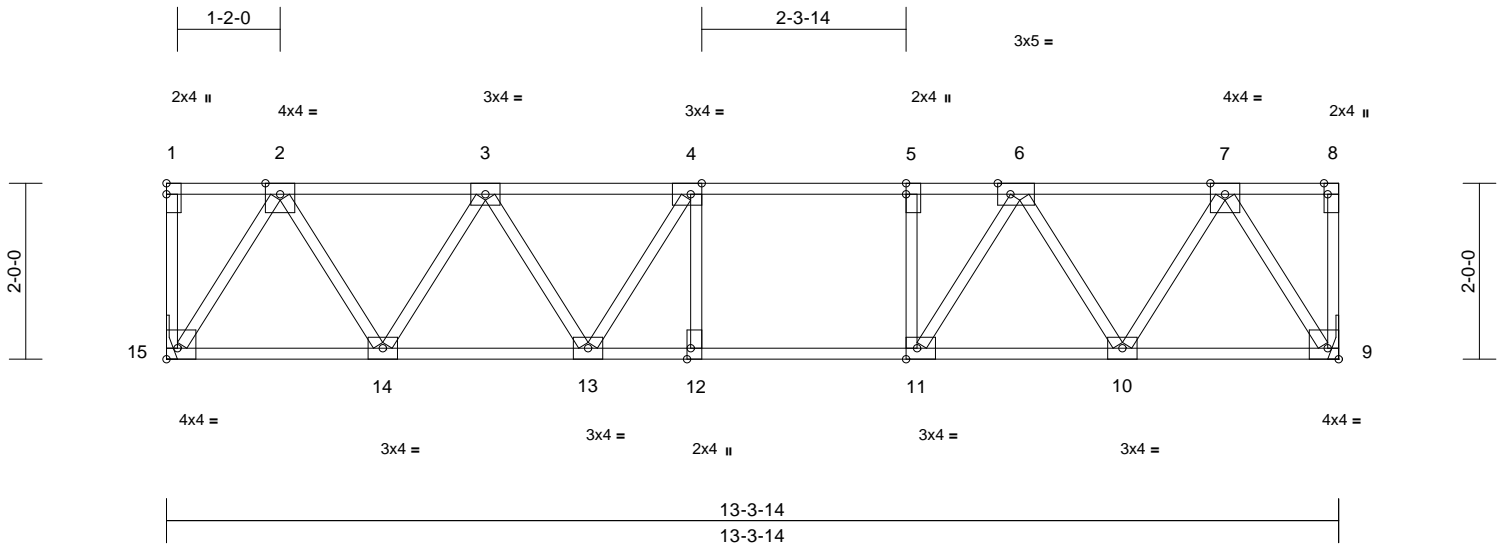

Scale = 1:26.2

Plate Offsets (X, Y): [4:0-1-8,Edge], [5:0-1-8,Edge], [6:0-1-12,Edge], [8:0-1-8,Edge], [9:Edge,0-1-8], [11:0-1-8,Edge], [12:0-1-8,Edge], [15:Edge,0-1-8]

Loading	(psf)	Spacing	1-4-0	CSI	DEFL	in	(loc)	l/defl	L/d	PLATES	GRIP	
TCLL	40.0	Plate Grip DOL	1.00	TC	0.49	Vert(LL)	-0.08	12-13	>999	360	MT20	244/190
TCDL	10.0	Lumber DOL	1.00	BC	0.55	Vert(CT)	-0.10	12-13	>999	240		
BCLL	0.0	Rep Stress Incr	YES	WB	0.11	Horz(CT)	0.01	9	n/a	n/a		
BCDL	5.0	Code	FBC2023/TPI2014	Matrix-AS							Weight: 77 lb	FT = 20%F, 11%E

LUMBER

TOP CHORD 2x4 SP No.2(flat)
BOT CHORD 2x4 SP No.2(flat)
WEBS 2x4 SP No.2(flat)

BRACING

TOP CHORD Structural wood sheathing directly applied, except end verticals.
BOT CHORD Rigid ceiling directly applied.

REACTIONS (size) 9= Mechanical, 15= Mechanical
Max Grav 9=484 (LC 1), 15=484 (LC 1)

FORCES (lb) - Maximum Compression/Maximum Tension
TOP CHORD 1-15=-26/0, 8-9=-21/0, 1-2=0/0, 2-3=-498/0, 3-4=-774/0, 4-5=-830/0, 5-6=-825/0, 6-7=-491/0, 7-8=0/0

BOT CHORD 14-15=0/297, 13-14=0/690, 12-13=0/831, 11-12=0/830, 10-11=0/683, 9-10=0/299

WEBS 7-9=-546/0, 2-15=-541/0, 7-10=0/364, 2-14=0/381, 6-10=-362/0, 3-14=-364/0, 6-11=0/356, 3-13=0/199, 4-13=-212/0, 4-12=-90/47, 5-11=-215/0

NOTES

- Unbalanced floor live loads have been considered for this design.
- Refer to girder(s) for truss to truss connections.
- This truss design requires that a minimum of 7/16" structural wood sheathing be applied directly to the top chord and 1/2" gypsum sheetrock be applied directly to the bottom chord.
- Recommend 2x6 strongbacks, on edge, spaced at 10-00-00 oc and fastened to each truss with 3-10d (0.131" X 3") nails. Strongbacks to be attached to walls at their outer ends or restrained by other means.

LOAD CASE(S) Standard

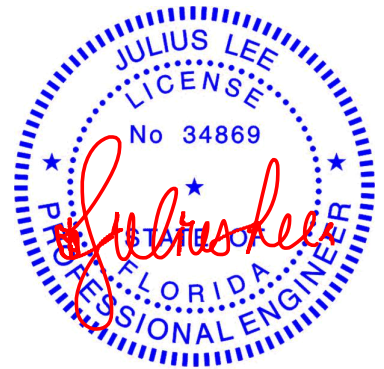

Julius Lee PE No. 34869
MiTek Inc. DBA MiTek USA FL Cert 6634
16023 Swingley Ridge Rd. Chesterfield, MO 63017
Date:

March 14, 2024

WARNING - Verify design parameters and READ NOTES ON THIS AND INCLUDED MITEK REFERENCE PAGE MII-7473 rev. 1/2/2023 BEFORE USE.

Design valid for use only with MiTek® connectors. This design is based only upon parameters shown, and is for an individual building component, not a truss system. Before use, the building designer must verify the applicability of design parameters and properly incorporate this design into the overall building design. Bracing indicated is to prevent buckling of individual truss web and/or chord members only. Additional temporary and permanent bracing is always required for stability and to prevent collapse with possible personal injury and property damage. For general guidance regarding the fabrication, storage, delivery, erection and bracing of trusses and truss systems, see **ANSI/TPI1 Quality Criteria and DSB-22** available from Truss Plate Institute (www.tpinst.org) and **BCSI Building Component Safety Information** available from the Structural Building Component Association (www.sbcsccomponents.com)

MiTek®

16023 Swingley Ridge Rd.
Chesterfield, MO 63017
314.434.1200 / MiTek-US.com

Job	Truss	Truss Type	Qty	Ply	Velo's Residence	T33229863
1398-A	F10	Floor Supported Gable	1	1	Job Reference (optional)	

19 Lumber, Inc., Old Town, FL - 32680,

Run: 8.73 S Feb 22 2024 Print: 8.730 S Feb 22 2024 MiTek Industries, Inc. Wed Mar 13 12:56:58
 ID:zNT?BZ0ScyRjIW53PNTs?7zdduv-RfC?PsB70Hq3NSgPqnL8w3uITXbGKWrCDoi7J4zJC?f

Page: 1

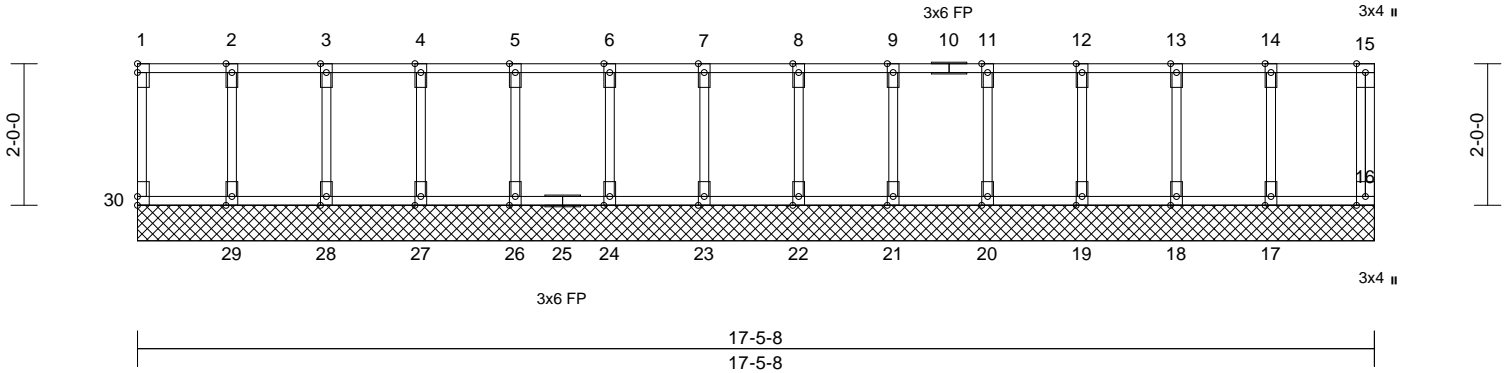

Scale = 1:32.5

Loading	(psf)	Spacing	1-4-0	CSI	DEFL	in	(loc)	l/defl	L/d	PLATES	GRIP	
TCLL	40.0	Plate Grip DOL	1.00	TC	0.51	Vert(LL)	n/a	-	n/a	999	MT20	244/190
TCDL	10.0	Lumber DOL	1.00	BC	0.12	Vert(TL)	n/a	-	n/a	999		
BCLL	0.0	Rep Stress Incr	NO	WB	0.12	Horiz(TL)	0.00	16	n/a	n/a		
BCDL	5.0	Code	FBC2023/TPI2014	Matrix-AS							Weight: 91 lb	FT = 20%F, 11%E

LUMBER
 TOP CHORD 2x4 SP No.2(flat)
 BOT CHORD 2x4 SP No.2(flat)
 WEBS 2x4 SP No.2(flat)
 OTHERS 2x4 SP No.2(flat)

BRACING
 TOP CHORD Structural wood sheathing directly applied, except end verticals.
 BOT CHORD Rigid ceiling directly applied.

REACTIONS (size) 16=17-5-8, 17=17-5-8, 18=17-5-8, 19=17-5-8, 20=17-5-8, 21=17-5-8, 22=17-5-8, 23=17-5-8, 24=17-5-8, 26=17-5-8, 27=17-5-8, 28=17-5-8, 29=17-5-8, 30=17-5-8
 Max Grav 16=360 (LC 1), 17=814 (LC 1), 18=770 (LC 1), 19=780 (LC 1), 20=777 (LC 1), 21=778 (LC 1), 22=778 (LC 1), 23=778 (LC 1), 24=778 (LC 1), 26=778 (LC 1), 27=778 (LC 1), 28=777 (LC 1), 29=786 (LC 1), 30=345 (LC 1)

FORCES (lb) - Maximum Compression/Maximum Tension
 TOP CHORD 1-30=-325/0, 15-16=-358/0, 1-2=-29/0, 2-3=-29/0, 3-4=-29/0, 4-5=-29/0, 5-6=-29/0, 6-7=-29/0, 7-8=-29/0, 8-9=-29/0, 9-11=-29/0, 11-12=-29/0, 12-13=-29/0, 13-14=-29/0, 14-15=-29/0
 BOT CHORD 29-30=0/29, 28-29=0/29, 27-28=0/29, 26-27=0/29, 24-26=0/29, 23-24=0/29, 22-23=0/29, 21-22=0/29, 20-21=0/29, 19-20=0/29, 18-19=0/29, 17-18=0/29, 16-17=0/29
 WEBS 2-29=-797/0, 3-28=-763/0, 4-27=-770/0, 5-26=-769/0, 6-24=-769/0, 7-23=-769/0, 8-22=-769/0, 9-21=-769/0, 11-20=-768/0, 12-19=-771/0, 13-18=-762/0, 14-17=-801/0

NOTES
 1) Unbalanced floor live loads have been considered for this design.

- All plates are 2x4 MT20 unless otherwise indicated.
 - Gable requires continuous bottom chord bearing.
 - Truss to be fully sheathed from one face or securely braced against lateral movement (i.e. diagonal web).
 - Gable studs spaced at 1-4-0 oc.
 - All bearings are assumed to be SP No.2 .
 - This truss design requires that a minimum of 7/16" structural wood sheathing be applied directly to the top chord and 1/2" gypsum sheetrock be applied directly to the bottom chord.
 - Recommend 2x6 strongbacks, on edge, spaced at 10-00-00 oc and fastened to each truss with 3-10d (0.131" X 3") nails. Strongbacks to be attached to walls at their outer ends or restrained by other means.
 - In the LOAD CASE(S) section, loads applied to the face of the truss are noted as front (F) or back (B).
- LOAD CASE(S)** Standard
 1) Dead + Floor Live (balanced): Lumber Increase=1.00, Plate Increase=1.00
 Uniform Loads (lb/ft)
 Vert: 16-30=-7, 1-15=-577 (F=-510)

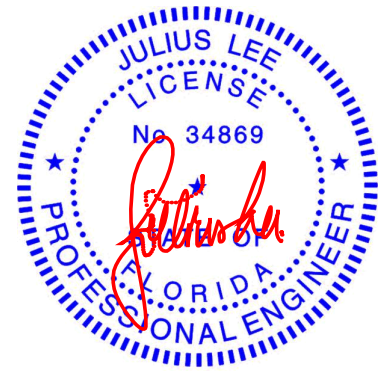

Julius Lee PE No. 34869
 MiTek Inc. DBA MiTek USA FL Cert 6634
 16023 Swingley Ridge Rd. Chesterfield, MO 63017
 Date:

March 14, 2024

WARNING - Verify design parameters and READ NOTES ON THIS AND INCLUDED MITEK REFERENCE PAGE MII-7473 rev. 1/2/2023 BEFORE USE.

Design valid for use only with MiTek® connectors. This design is based only upon parameters shown, and is for an individual building component, not a truss system. Before use, the building designer must verify the applicability of the design parameters and properly incorporate this design into the overall building design. Bracing indicated is to prevent buckling of individual truss web and/or chord members only. Additional temporary and permanent bracing is always required for stability and to prevent collapse with possible personal injury and property damage. For general guidance regarding the fabrication, storage, delivery, erection and bracing of trusses and truss systems, see **ANSI/TPI1 Quality Criteria and DSB-22** available from Truss Plate Institute (www.tpinst.org) and **BCSI Building Component Safety Information** available from the Structural Building Component Association (www.sbcscomponents.com)

MiTek®

16023 Swingley Ridge Rd.
 Chesterfield, MO 63017
 314.434.1200 / MiTek-US.com

Job 1398-A	Truss G1	Truss Type Common Supported Gable	Qty 2	Ply 1	Velo's Residence Job Reference (optional)	T33229864
---------------	-------------	--------------------------------------	----------	----------	--	-----------

19 Lumber, Inc., Old Town, FL - 32680,

Run: 8.73 S Feb 22 2024 Print: 8.730 S Feb 22 2024 MiTek Industries, Inc. Wed Mar 13 12:56:58
ID:2SAqvvt0QH6SrY4dgEUX1MzdeVe-RfC?PsB70Hq3NSgPqnL8w3uTXbGKwRCD0i7J4zJC7f

Page: 1

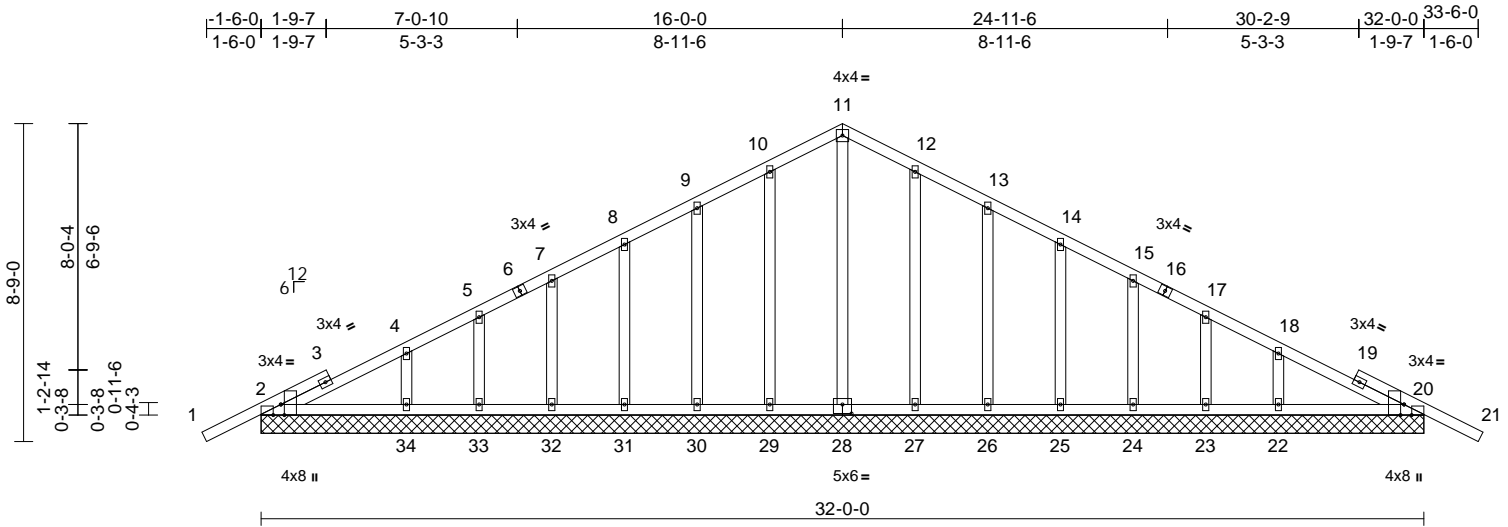

Scale = 1:63.4

Plate Offsets (X, Y): [2:0-3-8,Edge], [2:0-2-8,Edge], [20:0-3-8,Edge], [20:0-2-8,Edge], [28:0-3-0,0-3-0]

Loading	(psf)	Spacing	2-0-0	CSI	DEFL	in	(loc)	l/defl	L/d	PLATES	GRIP	
TCLL (roof)	20.0	Plate Grip DOL	1.25	TC	0.19	Vert(LL)	n/a	-	n/a	999	MT20	244/190
TCDL	10.0	Lumber DOL	1.25	BC	0.08	Vert(CT)	n/a	-	n/a	999		
BCLL	0.0*	Rep Stress Incr	YES	WB	0.21	Horz(CT)	0.01	20	n/a	n/a		
BCDL	10.0	Code	FBC2023/TPI2014	Matrix-MS								
											Weight: 192 lb	FT = 20%

LUMBER
TOP CHORD 2x4 SP No.2
BOT CHORD 2x4 SP No.2
OTHERS 2x4 SP No.2

BRACING
TOP CHORD Structural wood sheathing directly applied or 10-0-0 oc purlins.
BOT CHORD Rigid ceiling directly applied or 6-0-0 oc bracing.

REACTIONS (size)
2=32-0-0, 20=32-0-0, 22=32-0-0, 23=32-0-0, 24=32-0-0, 25=32-0-0, 26=32-0-0, 27=32-0-0, 28=32-0-0, 29=32-0-0, 30=32-0-0, 31=32-0-0, 32=32-0-0, 33=32-0-0, 34=32-0-0, 35=32-0-0, 38=32-0-0
Max Horiz 2=190 (LC 12), 35=190 (LC 12)
Max Uplift 2=-58 (LC 13), 20=-76 (LC 13), 22=-131 (LC 13), 23=-75 (LC 13), 24=-94 (LC 13), 25=-89 (LC 13), 26=-94 (LC 13), 27=-88 (LC 13), 29=90 (LC 12), 30=92 (LC 12), 31=-89 (LC 12), 32=-93 (LC 12), 33=-78 (LC 12), 34=-122 (LC 12), 35=-58 (LC 13), 38=-76 (LC 13)
Max Grav 2=246 (LC 25), 20=246 (LC 26), 22=280 (LC 26), 23=113 (LC 1), 24=172 (LC 26), 25=157 (LC 1), 26=159 (LC 1), 27=169 (LC 26), 28=219 (LC 22), 29=169 (LC 25), 30=159 (LC 1), 31=157 (LC 1), 32=172 (LC 25), 33=113 (LC 1), 34=280 (LC 25), 35=246 (LC 25), 38=246 (LC 26)

FORCES (lb) - Maximum Compression/Maximum Tension

TOP CHORD 1-2=0/42, 2-4=-202/114, 4-5=-126/118, 5-7=-75/137, 7-8=-42/164, 8-9=-54/211, 9-10=-76/287, 10-11=-99/357, 11-12=-99/357, 12-13=-76/287, 13-14=-54/211, 14-15=-32/138, 15-17=-13/65, 17-18=-45/44, 18-20=-124/84, 20-21=0/42
BOT CHORD 2-34=-73/225, 33-34=-73/225, 32-33=-73/225, 31-32=-73/225, 30-31=-73/225, 29-30=-73/225, 27-29=-73/225, 26-27=-73/225, 25-26=-73/225, 24-25=-73/225, 23-24=-73/225, 22-23=-73/225, 20-22=-73/225
WEBS 11-28=-200/19, 10-29=-129/139, 9-30=-119/149, 8-31=-119/143, 7-32=-126/149, 5-33=-94/132, 4-34=-192/195, 12-27=-129/139, 13-26=-119/149, 14-25=-119/143, 15-24=-126/149, 17-23=-94/132, 18-22=-192/194

NOTES
1) Unbalanced roof live loads have been considered for this design.
2) Wind: ASCE 7-22; Vult=130mph (3-second gust) Vasd=101mph; TCDL=5.0psf; BCDL=5.0psf; h=25ft; Cat. II; Exp C; Enclosed; MWFRS (envelope) exterior (2) zone and C-C Zone3 zone; cantilever left and right exposed; end vertical left and right exposed; C-C for members and forces & MWFRS for reactions shown; Lumber DOL=1.60 plate grip DOL=1.60
3) Truss designed for wind loads in the plane of the truss only. For studs exposed to wind (normal to the face), see Standard Industry Gable End Details as applicable, or consult qualified building designer as per ANSI/TPI 1.
4) Building Designer / Project engineer responsible for verifying applied roof live load shown covers rain loading requirements specific to the use of this truss component.
5) All plates are 2x4 MT20 unless otherwise indicated.

6) Gable requires continuous bottom chord bearing.
7) Gable studs spaced at 2-0-0 oc.
8) This truss has been designed for a 10.0 psf bottom chord live load nonconcurrent with any other live loads.
9) * This truss has been designed for a live load of 20.0psf on the bottom chord in all areas where a rectangle 3-06-00 tall by 2-00-00 wide will fit between the bottom chord and any other members.
10) All bearings are assumed to be SP No.2.
11) Provide mechanical connection (by others) of truss to bearing plate capable of withstanding 58 lb uplift at joint 2, 76 lb uplift at joint 20, 90 lb uplift at joint 29, 92 lb uplift at joint 30, 89 lb uplift at joint 31, 93 lb uplift at joint 32, 78 lb uplift at joint 33, 122 lb uplift at joint 34, 88 lb uplift at joint 27, 94 lb uplift at joint 26, 89 lb uplift at joint 25, 94 lb uplift at joint 24, 75 lb uplift at joint 23, 131 lb uplift at joint 22, 58 lb uplift at joint 2 and 76 lb uplift at joint 20.

LOAD CASE(S) Standard

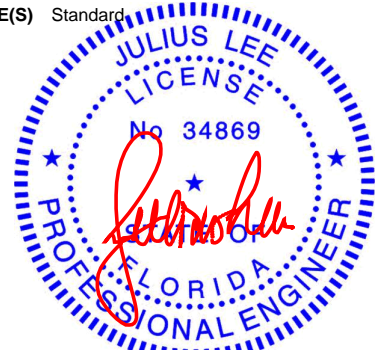

Julius Lee PE No. 34869
MiTek Inc. DBA MiTek USA FL Cert 6634
16023 Swingley Ridge Rd. Chesterfield, MO 63017
Date:

March 14, 2024

WARNING - Verify design parameters and READ NOTES ON THIS AND INCLUDED MITEK REFERENCE PAGE MII-7473 rev. 1/2023 BEFORE USE.

Design valid for use only with MiTek® connectors. This design is based only upon parameters shown, and is for an individual building component, not a truss system. Before use, the building designer must verify the applicability of the design parameters and properly incorporate this design into the overall building design. Bracing indicated is to prevent buckling of individual truss web and/or chord members only. Additional temporary and permanent bracing is always required for stability and to prevent collapse with possible personal injury and property damage. For general guidance regarding the fabrication, storage, delivery, erection and bracing of trusses and truss systems, see **ANSI/TPI1 Quality Criteria and DSB-22** available from Truss Plate Institute (www.tpinst.org) and **BCSI Building Component Safety Information** available from the Structural Building Component Association (www.sbcsccomponents.com)

MiTek®

16023 Swingley Ridge Rd.
Chesterfield, MO 63017
314.434.1200 / MiTek-US.com

Job 1398-A	Truss G2	Truss Type Common Supported Gable	Qty 3	Ply 1	Velo's Residence Job Reference (optional)	T33229865
---------------	-------------	--------------------------------------	----------	----------	--	-----------

19 Lumber, Inc., Old Town, FL - 32680,

Run: 8.73 S Feb 22 2024 Print: 8.730 S Feb 22 2024 MiTek Industries, Inc. Wed Mar 13 12:56:58
ID:2SAqv0TQH6SrY4dgEUX1MzdeVe-RfC?PsB70Hq3NSgPqnL8w3uTXbGKWRCDoi7J4zJC7f

Page: 1

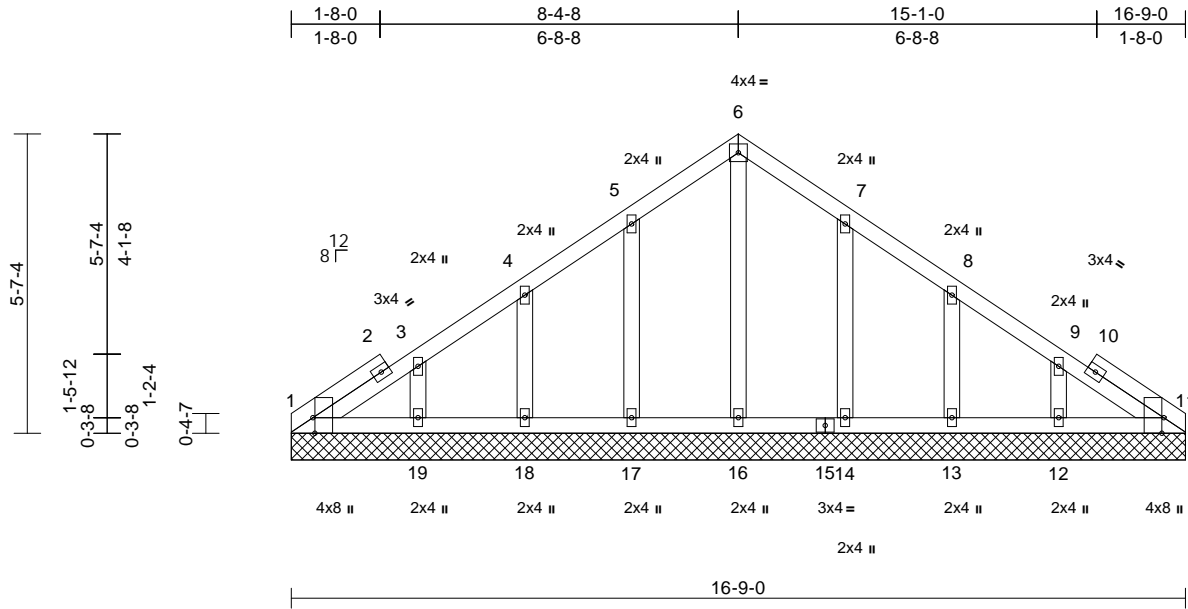

Scale = 1:43.2
Plate Offsets (X, Y): [1:0-3-8,Edge], [11:0-3-8,Edge]

Loading	(psf)	Spacing	2-0-0	CSI	DEFL	in	(loc)	l/defl	L/d	PLATES	GRIP	
TCLL (roof)	20.0	Plate Grip DOL	1.25	TC	0.07	Vert(LL)	n/a	-	n/a	999	MT20	244/190
TCDL	10.0	Lumber DOL	1.25	BC	0.05	Vert(TL)	n/a	-	n/a	999		
BCLL	0.0*	Rep Stress Incr	YES	WB	0.06	Horiz(TL)	0.00	11	n/a	n/a		
BCDL	10.0	Code	FBC2023/TPI2014	Matrix-MS							Weight: 89 lb	FT = 20%

LUMBER
TOP CHORD 2x4 SP No.2
BOT CHORD 2x4 SP No.2
OTHERS 2x4 SP No.2

BRACING
TOP CHORD Structural wood sheathing directly applied or 6-0-0 oc purlins.
BOT CHORD Rigid ceiling directly applied or 10-0-0 oc bracing.

REACTIONS (size) 1=16-9-0, 11=16-9-0, 12=16-9-0, 13=16-9-0, 14=16-9-0, 16=16-9-0, 17=16-9-0, 18=16-9-0, 19=16-9-0, 20=16-9-0, 23=16-9-0
Max Horiz 1=-175 (LC 8), 20=-175 (LC 8)
Max Uplift 1=-22 (LC 8), 12=-115 (LC 13), 13=-108 (LC 13), 14=-115 (LC 13), 17=-117 (LC 12), 18=-108 (LC 12), 19=-110 (LC 12), 20=-22 (LC 8)
Max Grav 1=106 (LC 20), 11=87 (LC 1), 12=217 (LC 20), 13=170 (LC 20), 14=192 (LC 20), 16=163 (LC 22), 17=193 (LC 19), 18=170 (LC 19), 19=212 (LC 19), 20=106 (LC 20), 23=87 (LC 1)

FORCES (lb) - Maximum Compression/Maximum Tension
TOP CHORD 1-3=-147/134, 3-4=-118/105, 4-5=-99/114, 5-6=-119/205, 6-7=-119/205, 7-8=-65/100, 8-9=-68/39, 9-11=-105/71
BOT CHORD 1-19=-61/132, 18-19=-61/132, 17-18=-61/132, 16-17=-61/132, 14-16=-61/132, 13-14=-61/132, 12-13=-61/132, 11-12=-61/132
WEBS 6-16=-123/20, 5-17=-151/169, 4-18=-137/171, 3-19=-145/156, 7-14=-150/169, 8-13=-138/171, 9-12=-151/156

- Unbalanced roof live loads have been considered for this design.
- Wind: ASCE 7-22; Vult=130mph (3-second gust) Vasd=101mph; TCDL=5.0psf; BCDL=5.0psf; h=25ft; Cat. II; Exp C; Enclosed; MWFRS (envelope) exterior (2) zone and C-C Zone3 zone; cantilever left and right exposed ; end vertical left and right exposed;C-C for members and forces & MWFRS for reactions shown; Lumber DOL=1.60 plate grip DOL=1.60
- Truss designed for wind loads in the plane of the truss only. For studs exposed to wind (normal to the face), see Standard Industry Gable End Details as applicable, or consult qualified building designer as per ANSI/TPI 1.
- Building Designer / Project engineer responsible for verifying applied roof live load shown covers rain loading requirements specific to the use of this truss component.
- Gable requires continuous bottom chord bearing.
- Gable studs spaced at 2-0-0 oc.
- This truss has been designed for a 10.0 psf bottom chord live load nonconcurrent with any other live loads.
- * This truss has been designed for a live load of 20.0psf on the bottom chord in all areas where a rectangle 3-06-00 tall by 2-00-00 wide will fit between the bottom chord and any other members.
- All bearings are assumed to be SP No.2 .
- Provide mechanical connection (by others) of truss to bearing plate capable of withstanding 22 lb uplift at joint 1, 117 lb uplift at joint 17, 108 lb uplift at joint 18, 110 lb uplift at joint 19, 115 lb uplift at joint 14, 108 lb uplift at joint 13, 115 lb uplift at joint 12 and 22 lb uplift at joint 1.

LOAD CASE(S) Standard



Julius Lee PE No. 34869
MiTek Inc. DBA MiTek USA FL Cert 6634
16023 Swingley Ridge Rd. Chesterfield, MO 63017
Date:

March 14, 2024

WARNING - Verify design parameters and READ NOTES ON THIS AND INCLUDED MITEK REFERENCE PAGE MII-7473 rev. 1/2/2023 BEFORE USE.

Design valid for use only with MiTek® connectors. This design is based only upon parameters shown, and is for an individual building component, not a truss system. Before use, the building designer must verify the applicability of design parameters and properly incorporate this design into the overall building design. Bracing indicated is to prevent buckling of individual truss web and/or chord members only. Additional temporary and permanent bracing is always required for stability and to prevent collapse with possible personal injury and property damage. For general guidance regarding the fabrication, storage, delivery, erection and bracing of trusses and truss systems, see **ANSI/TPI1 Quality Criteria and DSB-22** available from Truss Plate Institute (www.tpinst.org) and **BCSI Building Component Safety Information** available from the Structural Building Component Association (www.sbcscomponents.com)

MiTek®
16023 Swingley Ridge Rd.
Chesterfield, MO 63017
314.434.1200 / MiTek-US.com

Job 1398-A	Truss GA1	Truss Type Common Supported Gable	Qty 1	Ply 1	Velo's Residence Job Reference (optional)	T33229866
---------------	--------------	--------------------------------------	----------	----------	--	-----------

19 Lumber, Inc., Old Town, FL - 32680,

Run: 8.73 S Feb 22 2024 Print: 8.730 S Feb 22 2024 MiTek Industries, Inc. Wed Mar 13 12:56:58
ID:2SAqv0TQH6SrY4dgEUX1MzdeVe-RfC?PsB70Hq3NSgPqnL8w3uTXbGKWrCDoi7J4zJC7f

Page: 1

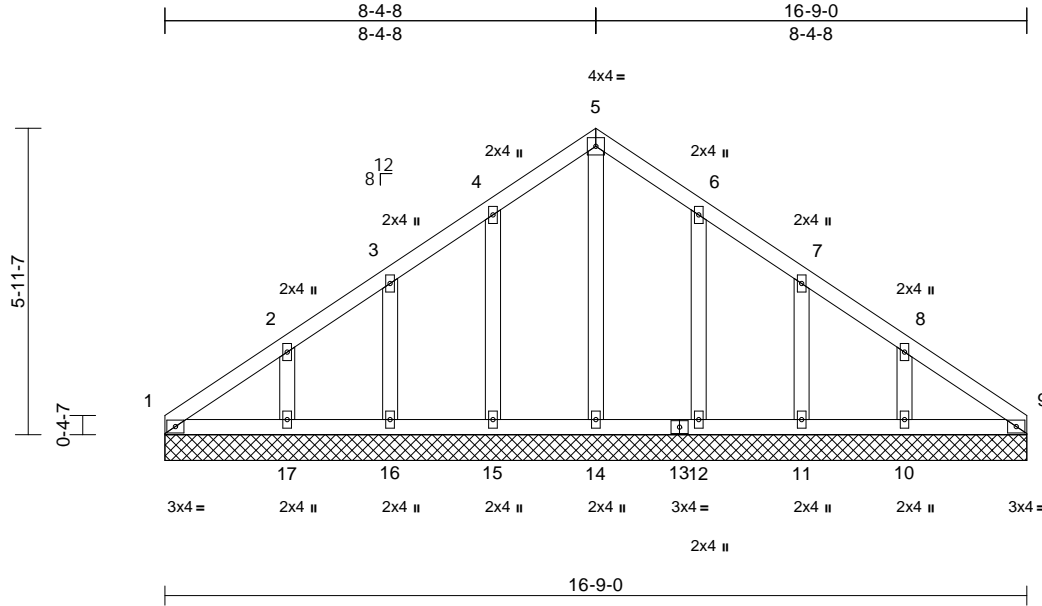

Loading	(psf)	Spacing	2-0-0	CSI	DEFL	in	(loc)	l/defl	L/d	PLATES	GRIP	
TCLL (roof)	20.0	Plate Grip DOL	1.25	TC	0.07	Vert(LL)	n/a	-	n/a	999	MT20	244/190
TCDL	10.0	Lumber DOL	1.25	BC	0.07	Vert(TL)	n/a	-	n/a	999		
BCLL	0.0*	Rep Stress Incr	YES	WB	0.07	Horiz(TL)	0.00	9	n/a	n/a		
BCDL	10.0	Code	FBC2023/TPI2014	Matrix-MS							Weight: 88 lb	FT = 20%

LUMBER
TOP CHORD 2x4 SP No.2
BOT CHORD 2x4 SP No.2
OTHERS 2x4 SP No.2

BRACING
TOP CHORD Structural wood sheathing directly applied or 6-0-0 oc purlins.
BOT CHORD Rigid ceiling directly applied or 10-0-0 oc bracing.

REACTIONS (size)
1=16-9-0, 9=16-9-0, 10=16-9-0, 11=16-9-0, 12=16-9-0, 14=16-9-0, 15=16-9-0, 16=16-9-0, 17=16-9-0, 18=16-9-0, 22=16-9-0
Max Horiz 1=186 (LC 9), 18=186 (LC 9)
Max Uplift 1=-39 (LC 8), 10=-145 (LC 13), 11=-101 (LC 13), 12=-116 (LC 13), 15=-118 (LC 12), 16=-100 (LC 12), 17=-146 (LC 12), 18=-39 (LC 8)
Max Grav 1=123 (LC 20), 9=94 (LC 19), 10=232 (LC 20), 11=164 (LC 20), 12=193 (LC 20), 14=165 (LC 22), 15=195 (LC 19), 16=163 (LC 19), 17=233 (LC 19), 18=123 (LC 20), 22=94 (LC 19)

FORCES (lb) - Maximum Compression/Maximum Tension
TOP CHORD 1-2=-157/141, 2-3=-123/104, 3-4=-104/126, 4-5=-132/226, 5-6=-132/226, 6-7=-78/120, 7-8=-73/37, 8-9=-112/73
BOT CHORD 1-17=-63/138, 16-17=-63/138, 15-16=-63/138, 14-15=-63/138, 12-14=-63/138, 11-12=-63/138, 10-11=-63/138, 9-10=-63/138
WEBS 5-14=-137/34, 4-15=-152/170, 3-16=-132/164, 2-17=-164/187, 6-12=-151/170, 7-11=-133/164, 8-10=-163/187

NOTES
1) Unbalanced roof live loads have been considered for this design.

- Wind: ASCE 7-22; Vult=130mph (3-second gust) Vasd=101mph; TC DL=5.0psf; BC DL=5.0psf; h=25ft; Cat. II; Exp C; Enclosed; MWFRS (envelope) exterior (2) zone and C-C Zone3 zone; cantilever left and right exposed ; end vertical left and right exposed; C-C for members and forces & MWFRS for reactions shown; Lumber DOL=1.60 plate grip DOL=1.60
 - Truss designed for wind loads in the plane of the truss only. For studs exposed to wind (normal to the face), see Standard Industry Gable End Details as applicable, or consult qualified building designer as per ANSI/TPI 1.
 - Building Designer / Project engineer responsible for verifying applied roof live load shown covers rain loading requirements specific to the use of this truss component.
 - Gable requires continuous bottom chord bearing.
 - Gable studs spaced at 2-0-0 oc.
 - This truss has been designed for a 10.0 psf bottom chord live load nonconcurrent with any other live loads.
 - * This truss has been designed for a live load of 20.0psf on the bottom chord in all areas where a rectangle 3-06-00 tall by 2-00-00 wide will fit between the bottom chord and any other members.
 - All bearings are assumed to be SP No.2 .
 - Provide mechanical connection (by others) of truss to bearing plate capable of withstanding 39 lb uplift at joint 1, 118 lb uplift at joint 15, 100 lb uplift at joint 16, 146 lb uplift at joint 17, 116 lb uplift at joint 12, 101 lb uplift at joint 11, 145 lb uplift at joint 10 and 39 lb uplift at joint 1.
- LOAD CASE(S)** Standard

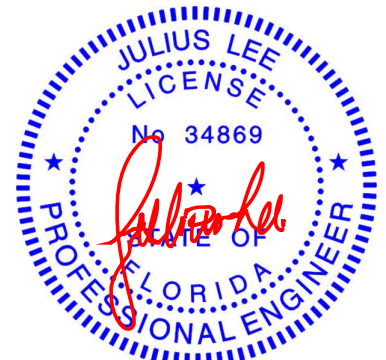

Julius Lee PE No. 34869
MiTek Inc. DBA MiTek USA FL Cert 6634
16023 Swingley Ridge Rd. Chesterfield, MO 63017
Date:

March 14, 2024

WARNING - Verify design parameters and READ NOTES ON THIS AND INCLUDED MITEK REFERENCE PAGE MII-7473 rev. 1/2023 BEFORE USE.

Design valid for use only with MiTek® connectors. This design is based only upon parameters shown, and is for an individual building component, not a truss system. Before use, the building designer must verify the applicability of design parameters and properly incorporate this design into the overall building design. Bracing indicated is to prevent buckling of individual truss web and/or chord members only. Additional temporary and permanent bracing is always required for stability and to prevent collapse with possible personal injury and property damage. For general guidance regarding the fabrication, storage, delivery, erection and bracing of trusses and truss systems, see **ANSI/TPI1 Quality Criteria and DSB-22** available from Truss Plate Institute (www.tpinst.org) and **BCSI Building Component Safety Information** available from the Structural Building Component Association (www.sbcsccomponents.com)

MiTek®

16023 Swingley Ridge Rd.
Chesterfield, MO 63017
314.434.1200 / MiTek-US.com

Job 1398-A	Truss GR1	Truss Type Flat Girder	Qty 1	Ply 2	Velo's Residence Job Reference (optional)	T33229867
---------------	--------------	---------------------------	----------	----------	--	-----------

19 Lumber, Inc., Old Town, FL - 32680,

Run: 8.73 S Feb 22 2024 Print: 8.730 S Feb 22 2024 MiTek Industries, Inc. Wed Mar 13 12:56:58
ID:Ny87pb3Lvtplczpe4V0Zdlzddus-RfC?PsB70Hq3NSgPqnL8w3uITXbGKWvRCDoi7J4zJC?f

Page: 1

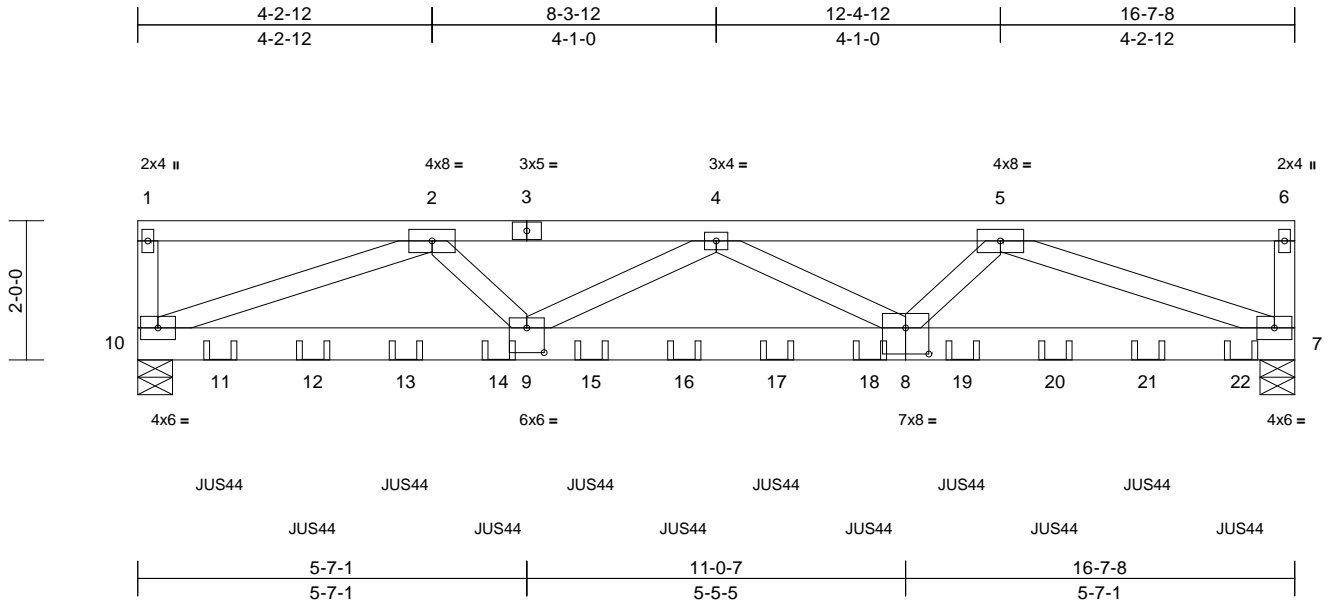

Scale = 1:33.1

Plate Offsets (X, Y): [8:0-4-0,0-4-8], [9:0-3-0,0-4-4]

Loading	(psf)	Spacing	2-0-0	CSI	DEFL	in	(loc)	l/defl	L/d	PLATES	GRIP	
TCLL (roof)	20.0	Plate Grip DOL	1.25	TC	0.53	Vert(LL)	-0.16	8-9	>999	240	MT20	244/190
TCDL	10.0	Lumber DOL	1.25	BC	0.52	Vert(CT)	-0.24	8-9	>818	180		
BCLL	0.0*	Rep Stress Incr	NO	WB	0.59	Horz(CT)	0.04	7	n/a	n/a		
BCDL	10.0	Code	FBC2023/TPI2014	Matrix-MS							Weight: 188 lb	FT = 20%

LUMBER
TOP CHORD 2x4 SP No.2
BOT CHORD 2x6 SP 2400F 2.0E
WEBS 2x4 SP No.2

BRACING
TOP CHORD Structural wood sheathing directly applied or 4-0-8 oc purlins, except end verticals.
BOT CHORD Rigid ceiling directly applied or 10-0-0 oc bracing.

REACTIONS (size) 7=0-6-0, 10=0-6-0
Max Horiz 10=79 (LC 7)
Max Grav 7=3223 (LC 14), 10=3078 (LC 14)

FORCES (lb) - Maximum Compression/Maximum Tension
TOP CHORD 1-10=-131/72, 1-2=-239/10, 2-4=-7522/0, 4-5=-7531/0, 5-6=-243/9, 6-7=-131/72
BOT CHORD 9-10=0/5714, 7-9=0/7630
WEBS 2-9=0/2816, 2-10=-5892/0, 4-9=-248/165, 4-8=-245/166, 5-8=0/2818, 5-7=-5896/0

- Building Designer / Project engineer responsible for verifying applied roof live load shown covers rain loading requirements specific to the use of this truss component.
- Provide adequate drainage to prevent water ponding.
- This truss has been designed for a 10.0 psf bottom chord live load nonconcurrent with any other live loads.
- * This truss has been designed for a live load of 20.0psf on the bottom chord in all areas where a rectangle 3-06-00 tall by 2-00-00 wide will fit between the bottom chord and any other members.
- All bearings are assumed to be SP 2400F 2.0E .
- Use MiTek JUS44 (With 4-16d nails into Girder & 2-16d nails into Truss) or equivalent spaced at 1-4-0 oc max. starting at 1-2-4 from the left end to 15-10-4 to connect truss(es) to front face of bottom chord.
- Fill all nail holes where hanger is in contact with lumber.

LOAD CASE(S) Standard

- Dead + Roof Live (balanced): Lumber Increase=1.25, Plate Increase=1.25
Uniform Loads (lb/ft)
Vert: 1-6=-60, 7-10=-20
Concentrated Loads (lb)
Vert: 11=-119 (F), 12=-119 (F), 13=-119 (F), 14=-119 (F), 15=-119 (F), 16=-119 (F), 17=-119 (F), 18=-119 (F), 19=-119 (F), 20=-119 (F), 21=-119 (F), 22=-119 (F)

- NOTES**
- 2-ply truss to be connected together with 10d (0.131"x3") nails as follows:
Top chords connected as follows: 2x4 - 1 row at 0-9-0 oc.
Bottom chords connected as follows: 2x6 - 2 rows staggered at 0-9-0 oc.
Web connected as follows: 2x4 - 1 row at 0-9-0 oc.
 - All loads are considered equally applied to all plies, except if noted as front (F) or back (B) face in the LOAD CASE(S) section. Ply to ply connections have been provided to distribute only loads noted as (F) or (B), unless otherwise indicated.
 - Wind: ASCE 7-22; Vult=130mph (3-second gust)
Vasd=101mph; TCDL=5.0psf; BCDL=5.0psf; h=25ft; Cat. II; Exp C; Enclosed; MWFRS (envelope) exterior (2) zone; cantilever left and right exposed ; end vertical left and right exposed; Lumber DOL=1.60 plate grip DOL=1.60



Julius Lee PE No. 34869
MiTek Inc. DBA MiTek USA FL Cert 6634
16023 Swingley Ridge Rd. Chesterfield, MO 63017
Date:

March 14, 2024

WARNING - Verify design parameters and READ NOTES ON THIS AND INCLUDED MITEK REFERENCE PAGE MII-7473 rev. 1/2/2023 BEFORE USE.

Design valid for use only with MiTek® connectors. This design is based only upon parameters shown, and is for an individual building component, not a truss system. Before use, the building designer must verify the applicability of design parameters and properly incorporate this design into the overall building design. Bracing indicated is to prevent buckling of individual truss web and/or chord members only. Additional temporary and permanent bracing is always required for stability and to prevent collapse with possible personal injury and property damage. For general guidance regarding the fabrication, storage, delivery, erection and bracing of trusses and truss systems, see **ANSI/TPI1 Quality Criteria and DSB-22** available from Truss Plate Institute (www.tpinst.org) and **BCSI Building Component Safety Information** available from the Structural Building Component Association (www.sbcsccomponents.com)

MiTek®
16023 Swingley Ridge Rd.
Chesterfield, MO 63017
314.434.1200 / MiTek-US.com

Job 1398-A	Truss S1	Truss Type Scissor	Qty 5	Ply 1	Velo's Residence Job Reference (optional)	T33229868
---------------	-------------	-----------------------	----------	----------	--	-----------

19 Lumber, Inc., Old Town, FL - 32680,

Run: 8.73 S Feb 22 2024 Print: 8.730 S Feb 22 2024 MiTek Industries, Inc. Wed Mar 13 12:56:58
ID:aGcShZ0rf_bDOVR7XzlU8zdeVf-RfC?PsB70Hq3NSgPqnL8w3uTXbGKWrCDoi7J4zJC7f

Page: 1

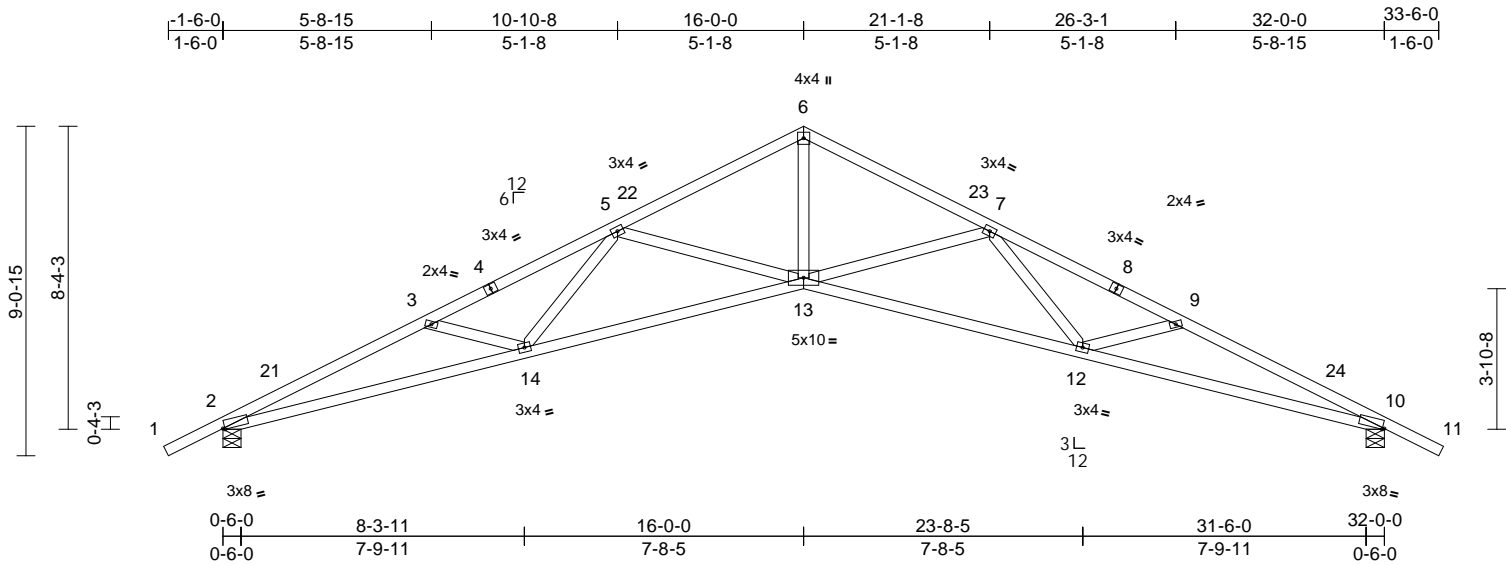

Scale = 1:63.5

Plate Offsets (X, Y): [2:0-0-10,Edge], [10:0-0-10,Edge]

Loading	(psf)	Spacing	2-0-0	CSI	DEFL	in	(loc)	l/defl	L/d	PLATES	GRIP	
TCLL (roof)	20.0	Plate Grip DOL	1.25	TC	0.67	Vert(LL)	0.39	13-14	>982	240	MT20	244/190
TCDL	10.0	Lumber DOL	1.25	BC	0.45	Vert(CT)	-0.78	12-13	>489	180		
BCLL	0.0*	Rep Stress Incr	YES	WB	0.50	Horz(CT)	0.48	10	n/a	n/a		
BCDL	10.0	Code	FBC2023/TPI2014	Matrix-MS							Weight: 149 lb	FT = 20%

LUMBER
TOP CHORD 2x4 SP No.2
BOT CHORD 2x4 SP 2400F 2.0E
WEBS 2x4 SP No.2

BRACING
TOP CHORD Structural wood sheathing directly applied or 2-2-0 oc purlins.
BOT CHORD Rigid ceiling directly applied or 7-1-3 oc bracing.

REACTIONS (size) 2=0-6-0, 10=0-6-0
Max Horiz 2=198 (LC 12)
Max Uplift 2=455 (LC 12), 10=455 (LC 13)
Max Grav 2=1374 (LC 1), 10=1374 (LC 1)

FORCES (lb) - Maximum Compression/Maximum Tension
TOP CHORD 1-2=0/42, 2-3=-4247/1405, 3-5=-3885/1190,
5-6=-2846/792, 6-7=-2846/778,
7-9=-3885/1066, 9-10=-4247/1212,
10-11=0/42
BOT CHORD 2-14=-1368/3843, 13-14=-980/3306,
12-13=-770/3306, 10-12=-1008/3843
WEBS 6-13=-536/2206, 7-13=-769/499,
7-12=-128/531, 9-12=-318/337,
5-13=-769/494, 5-14=-117/531,
3-14=-318/329

- Building Designer / Project engineer responsible for verifying applied roof live load shown covers rain loading requirements specific to the use of this truss component.
- This truss has been designed for a 10.0 psf bottom chord live load nonconcurrent with any other live loads.
- * This truss has been designed for a live load of 20.0psf on the bottom chord in all areas where a rectangle 3-06-00 tall by 2-00-00 wide will fit between the bottom chord and any other members.
- All bearings are assumed to be SP 2400F 2.0E .
- Bearing at joint(s) 2, 10 considers parallel to grain value using ANSI/TPI 1 angle to grain formula. Building designer should verify capacity of bearing surface.
- Provide mechanical connection (by others) of truss to bearing plate capable of withstanding 455 lb uplift at joint 2 and 455 lb uplift at joint 10.

LOAD CASE(S) Standard

- NOTES**
- Unbalanced roof live loads have been considered for this design.
 - Wind: ASCE 7-22; Vult=130mph (3-second gust)
Vasd=101mph; TCDL=5.0psf; BCDL=5.0psf; h=25ft; Cat. II; Exp C; Enclosed; MWFRS (envelope) exterior (2) zone and C-C Zone3 -1-6-13 to 1-7-10, Zone1 1-7-10 to 16-0-0, Zone2 16-0-0 to 20-6-5, Zone1 20-6-5 to 33-6-13 zone; cantilever left and right exposed ; end vertical left and right exposed;C-C for members and forces & MWFRS for reactions shown; Lumber DOL=1.60 plate grip DOL=1.60

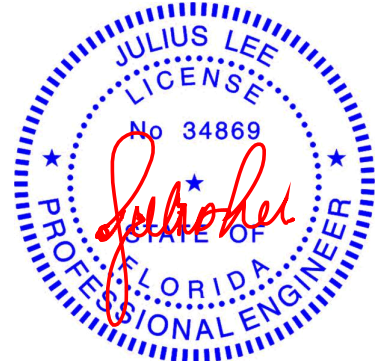

Julius Lee PE No. 34869
MiTek Inc. DBA MiTek USA FL Cert 6634
16023 Swingley Ridge Rd. Chesterfield, MO 63017
Date:

March 14,2024

WARNING - Verify design parameters and READ NOTES ON THIS AND INCLUDED MITEK REFERENCE PAGE MII-7473 rev. 1/2/2023 BEFORE USE.

Design valid for use only with MiTek® connectors. This design is based only upon parameters shown, and is for an individual building component, not a truss system. Before use, the building designer must verify the applicability of design parameters and properly incorporate this design into the overall building design. Bracing indicated is to prevent buckling of individual truss web and/or chord members only. Additional temporary and permanent bracing is always required for stability and to prevent collapse with possible personal injury and property damage. For general guidance regarding the fabrication, storage, delivery, erection and bracing of trusses and truss systems, see **ANSI/TPI1 Quality Criteria and DSB-22** available from Truss Plate Institute (www.tpinst.org) and **BCSI Building Component Safety Information** available from the Structural Building Component Association (www.sbcsccomponents.com)

MiTek®
16023 Swingley Ridge Rd.
Chesterfield, MO 63017
314.434.1200 / MiTek-US.com

Job 1398-A	Truss S3	Truss Type Common	Qty 5	Ply 1	Velo's Residence Job Reference (optional)	T33229870
---------------	-------------	----------------------	----------	----------	--	-----------

19 Lumber, Inc., Old Town, FL - 32680,

Run: 8.73 S Feb 22 2024 Print: 8.730 S Feb 22 2024 MiTek Industries, Inc. Wed Mar 13 12:56:59
ID:aGcShZ0r_bDOVR7XzIU8zdeVf-RfC?PsB70Hq3NSgPqnL8w3uTXbGKWrCDoi7J4zJC?f

Page: 1

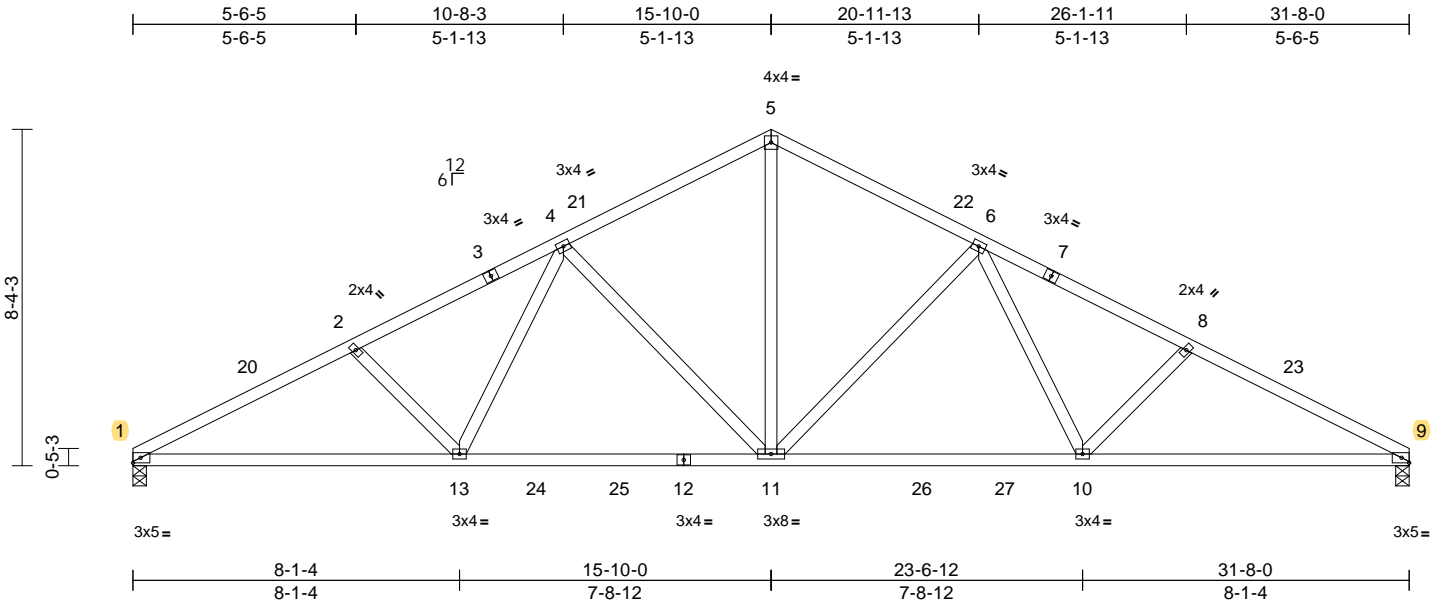

Scale = 1:57.2

Loading	(psf)	Spacing	2-0-0	CSI	DEFL	in	(loc)	l/defl	L/d	PLATES	GRIP	
TCLL (roof)	20.0	Plate Grip DOL	1.25	TC	0.32	Vert(LL)	-0.18	10-11	>999	240	MT20	244/190
TCDL	10.0	Lumber DOL	1.25	BC	0.83	Vert(CT)	-0.33	10-11	>999	180		
BCLL	0.0*	Rep Stress Incr	YES	WB	0.59	Horz(CT)	0.10	9	n/a	n/a		
BCDL	10.0	Code	FBC2023/TPI2014	Matrix-MS							Weight: 161 lb	FT = 20%

LUMBER
TOP CHORD 2x4 SP No.2
BOT CHORD 2x4 SP No.2
WEBS 2x4 SP No.2

BRACING
TOP CHORD Structural wood sheathing directly applied or 3-5-10 oc purlins.
BOT CHORD Rigid ceiling directly applied or 6-9-5 oc bracing.

REACTIONS (size) 1=0-4-0, 9=0-4-0
Max Horiz 1=178 (LC 12)
Max Uplift 1=-396 (LC 12), 9=-396 (LC 13)
Max Grav 1=1377 (LC 2), 9=1377 (LC 2)

FORCES (lb) - Maximum Compression/Maximum Tension
TOP CHORD 1-2=-2516/778, 2-4=-2331/736, 4-5=-1629/604, 5-6=-1629/604, 6-8=-2331/736, 8-9=-2516/778
BOT CHORD 1-13=-748/2203, 11-13=-511/1809, 10-11=-425/1809, 9-10=-597/2203
WEBS 5-11=-334/1164, 6-11=-603/372, 6-10=-129/532, 8-10=-295/265, 4-11=-603/372, 4-13=-128/532, 2-13=-295/265

- NOTES**
- Unbalanced roof live loads have been considered for this design.
 - Wind: ASCE 7-22; Vult=130mph (3-second gust) Vasd=101mph; TCDL=5.0psf; BCDL=5.0psf; h=25ft; Cat. II; Exp C; Enclosed; MWFRS (envelope) exterior (2) zone and C-C Zone3 0-2-0 to 3-4-0, Zone1 3-4-0 to 16-0-0, Zone2 16-0-0 to 20-5-12, Zone1 20-5-12 to 31-10-0 zone; cantilever left and right exposed; end vertical left and right exposed; C-C for members and forces & MWFRS for reactions shown; Lumber DOL=1.60 plate grip DOL=1.60
 - Building Designer / Project engineer responsible for verifying applied roof live load shown covers rain loading requirements specific to the use of this truss component.

- This truss has been designed for a 10.0 psf bottom chord live load nonconcurrent with any other live loads.
 - * This truss has been designed for a live load of 20.0psf on the bottom chord in all areas where a rectangle 3-06-00 tall by 2-00-00 wide will fit between the bottom chord and any other members, with BCDL = 10.0psf.
 - All bearings are assumed to be SP No.2 .
 - Provide mechanical connection (by others) of truss to bearing plate capable of withstanding 396 lb uplift at joint 1 and 396 lb uplift at joint 9.
- LOAD CASE(S)** Standard

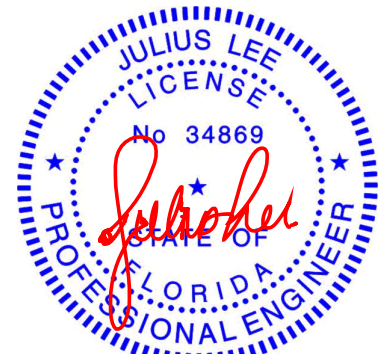

Julius Lee PE No. 34869
MiTek Inc. DBA MiTek USA FL Cert 6634
16023 Swingley Ridge Rd. Chesterfield, MO 63017
Date:

March 14, 2024

WARNING - Verify design parameters and READ NOTES ON THIS AND INCLUDED MITEK REFERENCE PAGE MII-7473 rev. 1/2/2023 BEFORE USE.

Design valid for use only with MiTek® connectors. This design is based only upon parameters shown, and is for an individual building component, not a truss system. Before use, the building designer must verify the applicability of design parameters and properly incorporate this design into the overall building design. Bracing indicated is to prevent buckling of individual truss web and/or chord members only. Additional temporary and permanent bracing is always required for stability and to prevent collapse with possible personal injury and property damage. For general guidance regarding the fabrication, storage, delivery, erection and bracing of trusses and truss systems, see **ANSI/TPI1 Quality Criteria and DSB-22** available from Truss Plate Institute (www.tpinst.org) and **BCSI Building Component Safety Information** available from the Structural Building Component Association (www.sbcsccomponents.com)

MiTek®

16023 Swingley Ridge Rd.
Chesterfield, MO 63017
314.434.1200 / MiTek-US.com

Job 1398-A	Truss V1	Truss Type Valley	Qty 4	Ply 1	Velo's Residence Job Reference (optional)	T33229871
---------------	-------------	----------------------	----------	----------	--	-----------

19 Lumber, Inc., Old Town, FL - 32680,

Run: 8.73 S Feb 22 2024 Print: 8.730 S Feb 22 2024 MiTek Industries, Inc. Wed Mar 13 12:56:59
ID:WekD6F15BbEJTrfpEy?maZzdeVd-RfC?PsB70Hq3NSgPqnL8w3uITXbGKWrCDoi7J4zJC?F

Page: 1

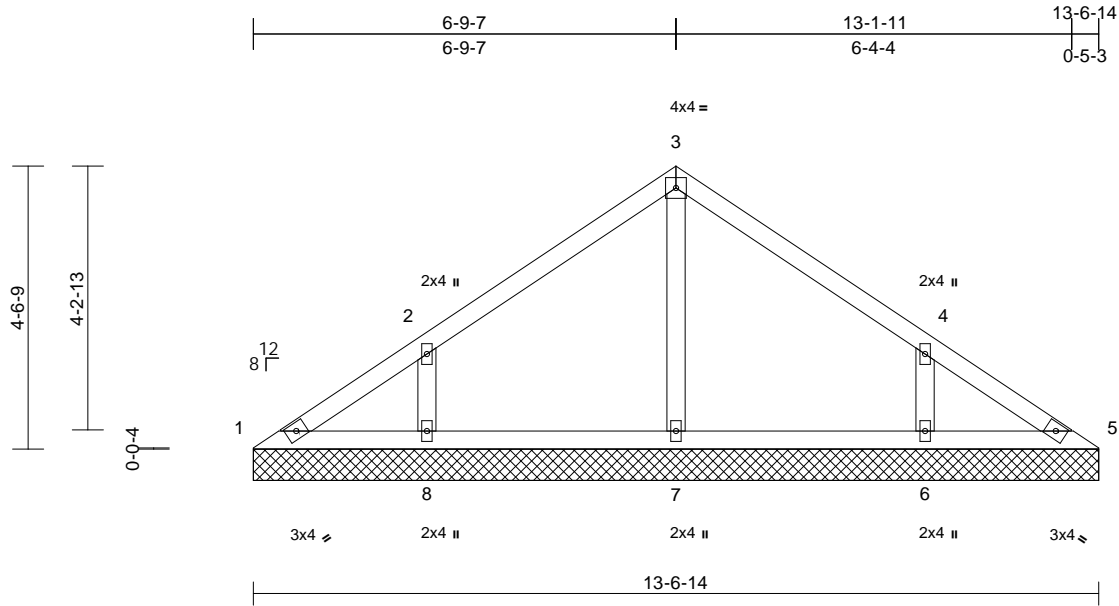

Scale = 1:37

Loading	(psf)	Spacing	2-0-0	CSI	DEFL	in	(loc)	l/defl	L/d	PLATES	GRIP	
TCLL (roof)	20.0	Plate Grip DOL	1.25	TC	0.19	Vert(LL)	n/a	-	n/a	999	MT20	244/190
TCDL	10.0	Lumber DOL	1.25	BC	0.12	Vert(TL)	n/a	-	n/a	999		
BCLL	0.0*	Rep Stress Incr	YES	WB	0.07	Horiz(TL)	0.00	5	n/a	n/a		
BCDL	10.0	Code	FBC2023/TPI2014	Matrix-MS							Weight: 53 lb	FT = 20%

LUMBER

TOP CHORD 2x4 SP No.2
BOT CHORD 2x4 SP No.2
OTHERS 2x4 SP No.2

BRACING

TOP CHORD Structural wood sheathing directly applied or 6-0-0 oc purlins.
BOT CHORD Rigid ceiling directly applied or 6-0-0 oc bracing.

REACTIONS

(size) 1=13-6-14, 5=13-6-14, 6=13-6-14, 7=13-6-14, 8=13-6-14
Max Horiz 1=-146 (LC 8)
Max Uplift 1=-31 (LC 13), 5=-7 (LC 12), 6=-217 (LC 13), 8=-219 (LC 12)
Max Grav 1=102 (LC 20), 5=80 (LC 1), 6=359 (LC 20), 7=291 (LC 1), 8=362 (LC 19)

FORCES

(lb) - Maximum Compression/Maximum Tension

TOP CHORD 1-2=-142/130, 2-3=-109/146, 3-4=-98/145, 4-5=-101/80
BOT CHORD 1-8=-56/117, 7-8=-52/87, 6-7=-52/87, 5-6=-52/87
WEBS 3-7=-210/43, 2-8=-283/300, 4-6=-282/300

NOTES

- Unbalanced roof live loads have been considered for this design.
- Wind: ASCE 7-22; Vult=130mph (3-second gust) Vasd=101mph; TCDL=5.0psf; BCDL=5.0psf; h=25ft; Cat. II; Exp C; Enclosed; MWFRS (envelope) exterior (2) zone and C-C Zone3 0-0-6 to 2-9-13, Zone1 2-9-13 to 6-9-13, Zone2 6-9-13 to 10-9-13, Zone1 10-9-13 to 13-7-4 zone; cantilever left and right exposed; end vertical left and right exposed; C-C for members and forces & MWFRS for reactions shown; Lumber DOL=1.60 plate grip DOL=1.60
- Truss designed for wind loads in the plane of the truss only. For studs exposed to wind (normal to the face), see Standard Industry Gable End Details as applicable, or consult qualified building designer as per ANSI/TPI 1.

- Building Designer / Project engineer responsible for verifying applied roof live load shown covers rain loading requirements specific to the use of this truss component.
- Gable requires continuous bottom chord bearing.
- Gable studs spaced at 4-0-0 oc.
- This truss has been designed for a 10.0 psf bottom chord live load nonconcurrent with any other live loads.
- * This truss has been designed for a live load of 20.0psf on the bottom chord in all areas where a rectangle 3-06-00 tall by 2-00-00 wide will fit between the bottom chord and any other members.
- All bearings are assumed to be SP No.2.
- Provide mechanical connection (by others) of truss to bearing plate capable of withstanding 31 lb uplift at joint 1, 7 lb uplift at joint 5, 219 lb uplift at joint 8 and 217 lb uplift at joint 6.

LOAD CASE(S) Standard

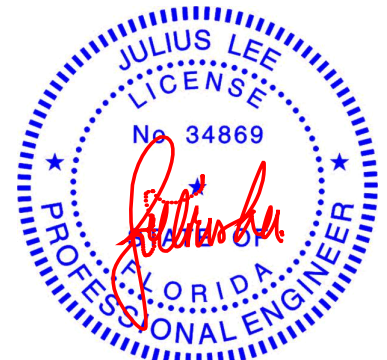

Julius Lee PE No. 34869
MiTek Inc. DBA MiTek USA FL Cert 6634
16023 Swingley Ridge Rd. Chesterfield, MO 63017
Date:

March 14, 2024

WARNING - Verify design parameters and READ NOTES ON THIS AND INCLUDED MITEK REFERENCE PAGE MII-7473 rev. 1/2/2023 BEFORE USE.

Design valid for use only with MiTek® connectors. This design is based only upon parameters shown, and is for an individual building component, not a truss system. Before use, the building designer must verify the applicability of design parameters and properly incorporate this design into the overall building design. Bracing indicated is to prevent buckling of individual truss web and/or chord members only. Additional temporary and permanent bracing is always required for stability and to prevent collapse with possible personal injury and property damage. For general guidance regarding the fabrication, storage, delivery, erection and bracing of trusses and truss systems, see **ANSI/TPI1 Quality Criteria and DSB-22** available from Truss Plate Institute (www.tpinst.org) and **BCSI Building Component Safety Information** available from the Structural Building Component Association (www.sbcsccomponents.com)

MiTek®

16023 Swingley Ridge Rd.
Chesterfield, MO 63017
314.434.1200 / MiTek-US.com

Job	Truss	Truss Type	Qty	Ply	Velo's Residence	T33229872
1398-A	V2	Valley	4	1	Job Reference (optional)	

19 Lumber, Inc., Old Town, FL - 32680,

Run: 8.73 S Feb 22 2024 Print: 8.730 S Feb 22 2024 MiTek Industries, Inc. Wed Mar 13 12:56:59
 ID:WekD6F15BbEJTrfpEy?maZzdeVd-RfC?PsB70Hq3NSgPqnL8w3uITXbGKWrCDoi7J4zJC?F

Page: 1

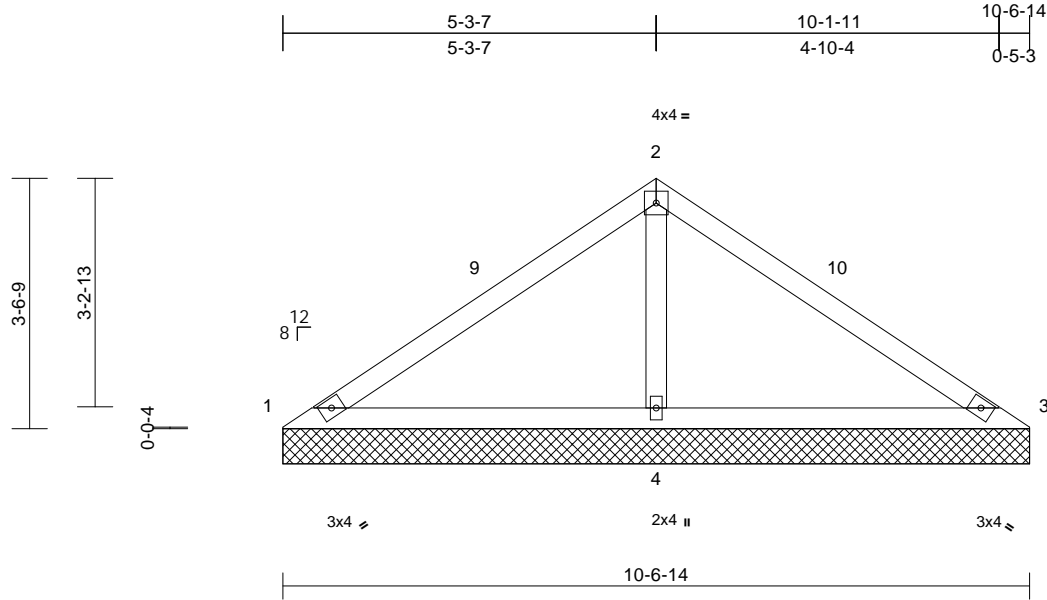

Scale = 1:32.6

Loading	(psf)	Spacing	2-0-0	CSI	DEFL	in	(loc)	l/defl	L/d	PLATES	GRIP	
TCLL (roof)	20.0	Plate Grip DOL	1.25	TC	0.30	Vert(LL)	n/a	-	n/a	999	MT20	244/190
TCDL	10.0	Lumber DOL	1.25	BC	0.34	Vert(TL)	n/a	-	n/a	999		
BCLL	0.0*	Rep Stress Incr	YES	WB	0.12	Horiz(TL)	0.00	4	n/a	n/a		
BCDL	10.0	Code	FBC2023/TPI2014	Matrix-MS							Weight: 37 lb	FT = 20%

LUMBER
 TOP CHORD 2x4 SP No.2
 BOT CHORD 2x4 SP No.2
 OTHERS 2x4 SP No.2

BRACING
 TOP CHORD Structural wood sheathing directly applied or 10-0-0 oc purlins.
 BOT CHORD Rigid ceiling directly applied or 6-0-0 oc bracing.

REACTIONS (size) 1=10-6-14, 3=10-6-14, 4=10-6-14
 Max Horiz 1=112 (LC 11)
 Max Uplift 1=-38 (LC 26), 3=-38 (LC 25), 4=-278 (LC 12)
 Max Grav 1=67 (LC 25), 3=67 (LC 26), 4=807 (LC 1)

FORCES (lb) - Maximum Compression/Maximum Tension
 TOP CHORD 1-2=-284/387, 2-3=-287/387
 BOT CHORD 1-4=-342/364, 3-4=-342/364
 WEBS 2-4=-636/559

- NOTES**
- Unbalanced roof live loads have been considered for this design.
 - Wind: ASCE 7-22; Vult=130mph (3-second gust) Vasd=101mph; TCDL=5.0psf; BCDL=5.0psf; h=25ft; Cat. II; Exp C; Enclosed; MWFRS (envelope) exterior (2) zone and C-C Zone3 0-0-6 to 3-0-6, Zone1 3-0-6 to 5-3-13, Zone2 5-3-13 to 9-8-1, Zone1 9-8-1 to 10-7-4 zone; cantilever left and right exposed ; end vertical left and right exposed;C-C for members and forces & MWFRS for reactions shown; Lumber DOL=1.60 plate grip DOL=1.60
 - Truss designed for wind loads in the plane of the truss only. For studs exposed to wind (normal to the face), see Standard Industry Gable End Details as applicable, or consult qualified building designer as per ANSI/TPI 1.
 - Building Designer / Project engineer responsible for verifying applied roof live load shown covers rain loading requirements specific to the use of this truss component.

- Gable requires continuous bottom chord bearing.
- Gable studs spaced at 4-0-0 oc.
- This truss has been designed for a 10.0 psf bottom chord live load nonconcurrent with any other live loads.
- * This truss has been designed for a live load of 20.0psf on the bottom chord in all areas where a rectangle 3-06-00 tall by 2-00-00 wide will fit between the bottom chord and any other members.
- All bearings are assumed to be SP No.2 .
- Provide mechanical connection (by others) of truss to bearing plate capable of withstanding 38 lb uplift at joint 1, 38 lb uplift at joint 3 and 278 lb uplift at joint 4.

LOAD CASE(S) Standard

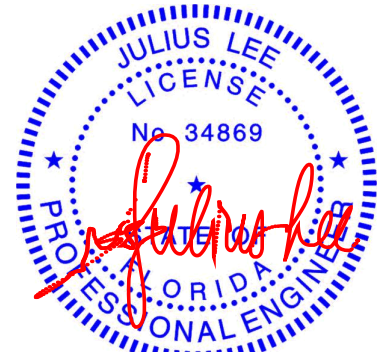

Julius Lee PE No. 34869
 MiTek Inc. DBA MiTek USA FL Cert 6634
 16023 Swingley Ridge Rd. Chesterfield, MO 63017
 Date:

March 14,2024

WARNING - Verify design parameters and READ NOTES ON THIS AND INCLUDED MITEK REFERENCE PAGE MII-7473 rev. 1/2/2023 BEFORE USE.

Design valid for use only with MiTek® connectors. This design is based only upon parameters shown, and is for an individual building component, not a truss system. Before use, the building designer must verify the applicability of design parameters and properly incorporate this design into the overall building design. Bracing indicated is to prevent buckling of individual truss web and/or chord members only. Additional temporary and permanent bracing is always required for stability and to prevent collapse with possible personal injury and property damage. For general guidance regarding the fabrication, storage, delivery, erection and bracing of trusses and truss systems, see **ANSI/TPI1 Quality Criteria and DSB-22** available from Truss Plate Institute (www.tpinst.org) and **BCSI Building Component Safety Information** available from the Structural Building Component Association (www.sbcsccomponents.com)

MiTek®

16023 Swingley Ridge Rd.
 Chesterfield, MO 63017
 314.434.1200 / MiTek-US.com

Job 1398-A	Truss V3	Truss Type Valley	Qty 4	Ply 1	Velo's Residence Job Reference (optional)	T33229873
---------------	-------------	----------------------	----------	----------	--	-----------

19 Lumber, Inc., Old Town, FL - 32680,

Run: 8.73 S Feb 22 2024 Print: 8.730 S Feb 22 2024 MiTek Industries, Inc. Wed Mar 13 12:56:59
ID:WekD6F15BbEJTrfpEy?maZzdeVdRfC?PsB70Hq3NSgPqnL8w3uITxBGKWrCDoi7J4zJC?F

Page: 1

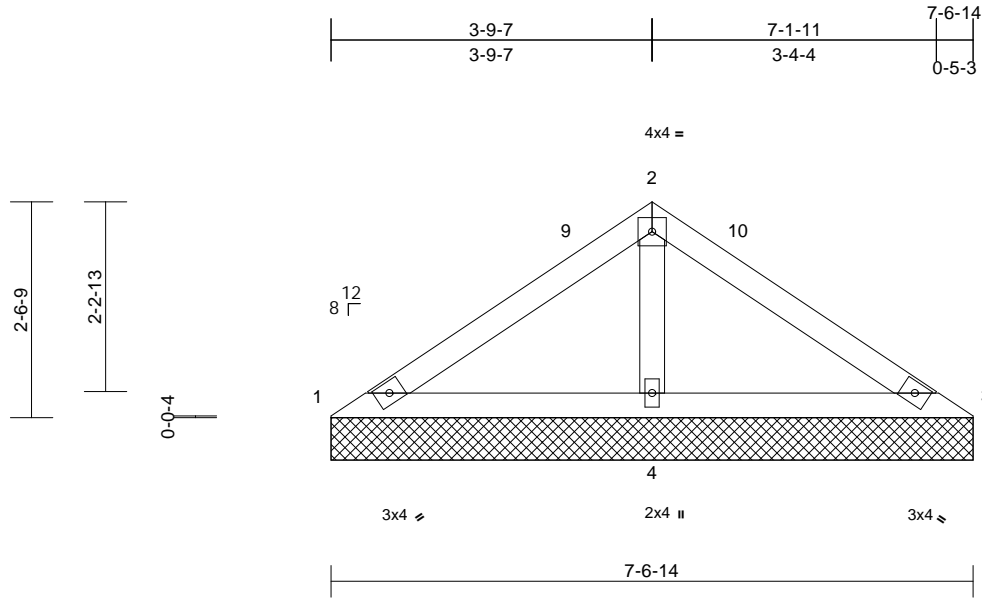

Scale = 1:27.2

Loading	(psf)	Spacing	2-0-0	CSI	DEFL	in	(loc)	l/defl	L/d	PLATES	GRIP	
TCLL (roof)	20.0	Plate Grip DOL	1.25	TC	0.19	Vert(LL)	n/a	-	n/a	999	MT20	244/190
TCDL	10.0	Lumber DOL	1.25	BC	0.27	Vert(TL)	n/a	-	n/a	999		
BCLL	0.0*	Rep Stress Incr	YES	WB	0.08	Horiz(TL)	0.00	3	n/a	n/a		
BCDL	10.0	Code	FBC2023/TPI2014	Matrix-MP							Weight: 26 lb	FT = 20%

LUMBER

TOP CHORD 2x4 SP No.2
BOT CHORD 2x4 SP No.2
OTHERS 2x4 SP No.2

BRACING

TOP CHORD Structural wood sheathing directly applied or 7-6-14 oc purlins.
BOT CHORD Rigid ceiling directly applied or 6-0-0 oc bracing.

REACTIONS

(size) 1=7-6-14, 3=7-6-14, 4=7-6-14
Max Horiz 1=79 (LC 9)
Max Uplift 1=-7 (LC 26), 3=-22 (LC 8), 4=-175 (LC 12)
Max Grav 1=68 (LC 25), 3=68 (LC 26), 4=525 (LC 1)

FORCES

(lb) - Maximum Compression/Maximum Tension

TOP CHORD 1-2=-209/227, 2-3=-224/226
BOT CHORD 1-4=-230/328, 3-4=-230/328
WEBS 2-4=-388/438

NOTES

- Unbalanced roof live loads have been considered for this design.
- Wind: ASCE 7-22; Vult=130mph (3-second gust) Vasd=101mph; TCDL=5.0psf; BCDL=5.0psf; h=25ft; Cat. II; Exp C; Enclosed; MWFRS (envelope) exterior (2) zone and C-C Zone3 0-0-6 to 3-0-6, Zone1 3-0-6 to 3-9-13, Zone3 3-9-13 to 7-7-4 zone; cantilever left and right exposed; end vertical left and right exposed; C-C for members and forces & MWFRS for reactions shown; Lumber DOL=1.60 plate grip DOL=1.60
- Truss designed for wind loads in the plane of the truss only. For studs exposed to wind (normal to the face), see Standard Industry Gable End Details as applicable, or consult qualified building designer as per ANSI/TPI 1.
- Building Designer / Project engineer responsible for verifying applied roof live load shown covers rain loading requirements specific to the use of this truss component.
- Gable requires continuous bottom chord bearing.

- Gable studs spaced at 4-0-0 oc.
- This truss has been designed for a 10.0 psf bottom chord live load nonconcurrent with any other live loads.
- * This truss has been designed for a live load of 20.0psf on the bottom chord in all areas where a rectangle 3-06-00 tall by 2-00-00 wide will fit between the bottom chord and any other members.
- All bearings are assumed to be SP No.2 .
- Provide mechanical connection (by others) of truss to bearing plate capable of withstanding 7 lb uplift at joint 1, 22 lb uplift at joint 3 and 175 lb uplift at joint 4.

LOAD CASE(S) Standard

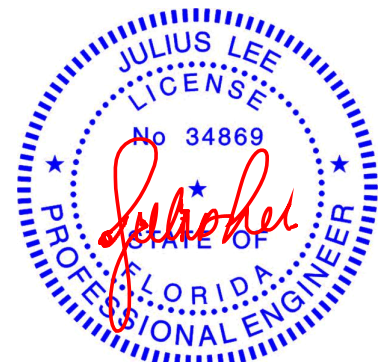

Julius Lee PE No. 34869
MiTek Inc. DBA MiTek USA FL Cert 6634
16023 Swingley Ridge Rd. Chesterfield, MO 63017
Date:

March 14, 2024

WARNING - Verify design parameters and READ NOTES ON THIS AND INCLUDED MITEK REFERENCE PAGE MII-7473 rev. 1/2/2023 BEFORE USE.

Design valid for use only with MiTek® connectors. This design is based only upon parameters shown, and is for an individual building component, not a truss system. Before use, the building designer must verify the applicability of design parameters and properly incorporate this design into the overall building design. Bracing indicated is to prevent buckling of individual truss web and/or chord members only. Additional temporary and permanent bracing is always required for stability and to prevent collapse with possible personal injury and property damage. For general guidance regarding the fabrication, storage, delivery, erection and bracing of trusses and truss systems, see **ANSI/TPI1 Quality Criteria and DSB-22** available from Truss Plate Institute (www.tpinst.org) and **BCSI Building Component Safety Information** available from the Structural Building Component Association (www.sbcsccomponents.com)

MiTek®

16023 Swingley Ridge Rd.
Chesterfield, MO 63017
314.434.1200 / MiTek-US.com

Job 1398-A	Truss V4	Truss Type Valley	Qty 4	Ply 1	Velo's Residence Job Reference (optional) T33229874
---------------	-------------	----------------------	----------	----------	---

19 Lumber, Inc., Old Town, FL - 32680,

Run: 8.73 S Feb 22 2024 Print: 8.730 S Feb 22 2024 MiTek Industries, Inc. Wed Mar 13 12:56:59
ID:WekD6F15BbEJTfPey?maZzdeVd-RfC?PsB70Hq3NSgPqnL8w3uITXbGKWrCDoi7J4zJC?

Page: 1

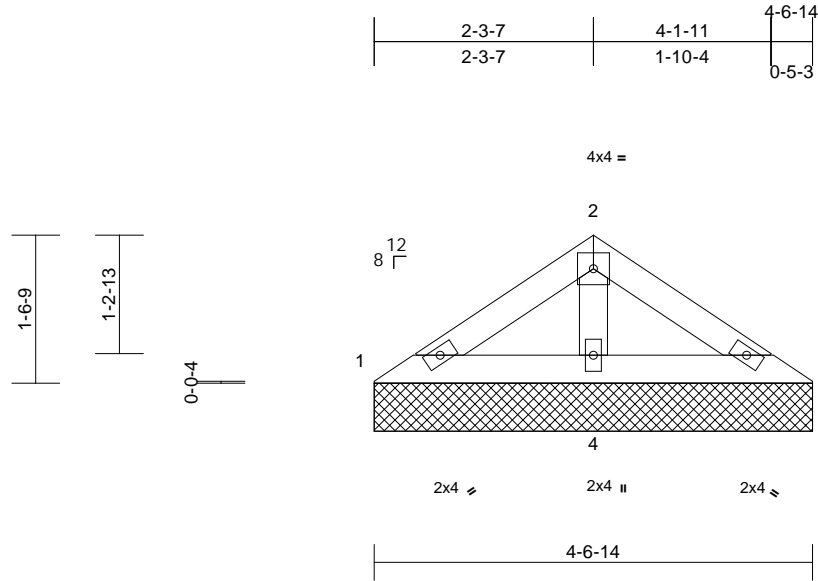

Scale = 1:24

Loading	(psf)	Spacing	2-0-0	CSI	DEFL	in	(loc)	l/defl	L/d	PLATES	GRIP	
TCLL (roof)	20.0	Plate Grip DOL	1.25	TC	0.05	Vert(LL)	n/a	-	n/a	999	MT20	244/190
TCDL	10.0	Lumber DOL	1.25	BC	0.10	Vert(TL)	n/a	-	n/a	999		
BCLL	0.0*	Rep Stress Incr	YES	WB	0.03	Horiz(TL)	0.00	4	n/a	n/a		
BCDL	10.0	Code	FBC2023/TPI2014	Matrix-MP							Weight: 15 lb	FT = 20%

LUMBER

TOP CHORD 2x4 SP No.2
BOT CHORD 2x4 SP No.2
OTHERS 2x4 SP No.2

BRACING

TOP CHORD Structural wood sheathing directly applied or 4-6-14 oc purlins.
BOT CHORD Rigid ceiling directly applied or 6-0-0 oc bracing.

REACTIONS

(size) 1=4-6-14, 3=4-6-14, 4=4-6-14
Max Horiz 1=-46 (LC 8)
Max Uplift 1=-16 (LC 12), 3=-24 (LC 13), 4=-79 (LC 12)
Max Grav 1=60 (LC 25), 3=60 (LC 26), 4=266 (LC 1)

FORCES

(lb) - Maximum Compression/Maximum Tension

TOP CHORD 1-2=-56/89, 2-3=-56/85
BOT CHORD 1-4=-93/148, 3-4=-93/148
WEBS 2-4=-159/192

NOTES

- Unbalanced roof live loads have been considered for this design.
- Wind: ASCE 7-22; Vult=130mph (3-second gust) Vasd=101mph; TCDL=5.0psf; BCDL=5.0psf; h=25ft; Cat. II; Exp C; Enclosed; MWFRS (envelope) exterior (2) zone and C-C Zone3 zone; cantilever left and right exposed; end vertical left and right exposed; C-C for members and forces & MWFRS for reactions shown; Lumber DOL=1.60 plate grip DOL=1.60
- Truss designed for wind loads in the plane of the truss only. For studs exposed to wind (normal to the face), see Standard Industry Gable End Details as applicable, or consult qualified building designer as per ANSI/TPI 1.
- Building Designer / Project engineer responsible for verifying applied roof live load shown covers rain loading requirements specific to the use of this truss component.
- Gable requires continuous bottom chord bearing.
- Gable studs spaced at 4-0-0 oc.

- This truss has been designed for a 10.0 psf bottom chord live load nonconcurrent with any other live loads.
- * This truss has been designed for a live load of 20.0psf on the bottom chord in all areas where a rectangle 3-06-00 tall by 2-00-00 wide will fit between the bottom chord and any other members.
- All bearings are assumed to be SP No.2 .
- Provide mechanical connection (by others) of truss to bearing plate capable of withstanding 16 lb uplift at joint 1, 24 lb uplift at joint 3 and 79 lb uplift at joint 4.

LOAD CASE(S) Standard

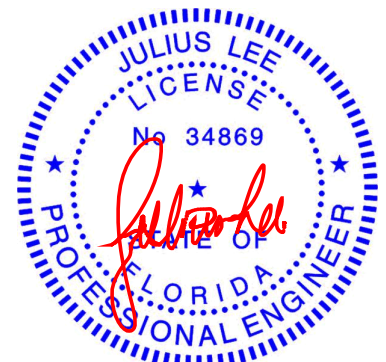

Julius Lee PE No. 34869
MiTek Inc. DBA MiTek USA FL Cert 6634
16023 Swingley Ridge Rd. Chesterfield, MO 63017
Date:

March 14, 2024

WARNING - Verify design parameters and READ NOTES ON THIS AND INCLUDED MITEK REFERENCE PAGE MII-7473 rev. 1/2/2023 BEFORE USE.

Design valid for use only with MiTek® connectors. This design is based only upon parameters shown, and is for an individual building component, not a truss system. Before use, the building designer must verify the applicability of design parameters and properly incorporate this design into the overall building design. Bracing indicated is to prevent buckling of individual truss web and/or chord members only. Additional temporary and permanent bracing is always required for stability and to prevent collapse with possible personal injury and property damage. For general guidance regarding the fabrication, storage, delivery, erection and bracing of trusses and truss systems, see **ANSI/TPI1 Quality Criteria and DSB-22** available from Truss Plate Institute (www.tpinst.org) and **BCSI Building Component Safety Information** available from the Structural Building Component Association (www.sbcsccomponents.com)

MiTek®

16023 Swingley Ridge Rd.
Chesterfield, MO 63017
314.434.1200 / MiTek-US.com

Symbols

PLATE LOCATION AND ORIENTATION

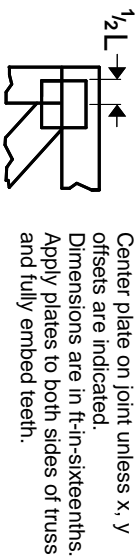

Center plate on joint unless x, y offsets are indicated. Dimensions are in ft-in-sixteenths. Apply plates to both sides of truss and fully embed teeth.

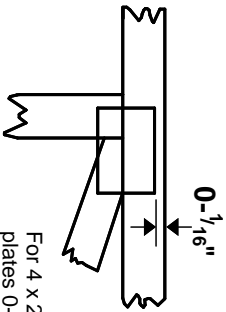

For 4 x 2 orientation, locate plates 0- 1/16\" from outside edge of truss.



This symbol indicates the required direction of slots in connector plates.

* Plate location details available in MITtek software or upon request.

PLATE SIZE

4 X 4

The first dimension is the plate width measured perpendicular to slots. Second dimension is the length parallel to slots.

LATERAL BRACING LOCATION



Indicated by symbol shown and/or by text in the bracing section of the output. Use T or I bracing if indicated.

BEARING

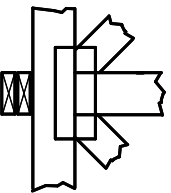

Indicates location where bearings (supports) occur. Icons vary but reaction section indicates joint number/letter where bearings occur. Min size shown is for crushing only.

Industry Standards:

ANSI/TP1: National Design Specification for Metal Plate Connected Wood Truss Construction.
DSB-22: Design Standard for Bracing.
BCSI: Building Component Safety Information, Guide to Good Practice for Handling, Installing, Restraining & Bracing of Metal Plate Connected Wood Trusses.

Numbering System

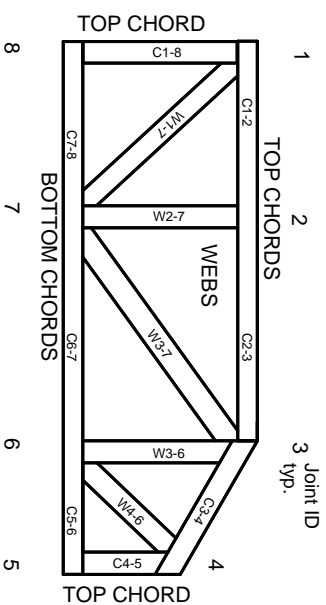

JOINTS ARE GENERALLY NUMBERED/LETTERED CLOCKWISE AROUND THE TRUSS STARTING AT THE JOINT FARTHEST TO THE LEFT.

CHORDS AND WEBS ARE IDENTIFIED BY END JOINT NUMBERS/LETTERS.

Product Code Approvals

ICC-ES Reports:

ESR-1-1988, ESR-2-362, ESR-2-685, ESR-3-282
ESR-4-722, ESL-1-388

Design General Notes

Trusses are designed for wind loads in the plane of the truss unless otherwise shown.

Lumber design values are in accordance with ANSI/TP1 section 6.3. These truss designs rely on Lumber values established by others.

© 2023 MITtek® All Rights Reserved

General Safety Notes

Failure to Follow Could Cause Property Damage or Personal Injury

1. Additional stability/bracing for truss system, e.g. diagonal or X-bracing, is always required. See BCSI.
2. Truss bracing must be designed by an engineer. For wide truss spacing, individual lateral braces themselves may require bracing, or alternative Tor I bracing should be considered.
3. Never exceed the design loading shown and never stack materials on inadequately braced trusses.
4. Provide copies of this truss design to the building designer, erection supervisor, property owner and all other interested parties.
5. Cut members to bear tightly against each other.
6. Place plates on each face of truss at each joint and embed fully. Knots and wane at joint locations are regulated by ANSI/TP1 1.
7. Design assumes trusses will be suitably protected from the environment in accord with ANSI/TP1 1.
8. Unless otherwise noted, moisture content of lumber shall not exceed 19% at time of fabrication.
9. Unless expressly noted, this design is not applicable for use with fire retardant, preservative treated, or green lumber.
10. Camber is a non-structural consideration and is the responsibility of truss fabricator. General practice is to camber for dead load deflection.
11. Plate type, size, orientation and location dimensions indicated are minimum plating requirements.
12. Lumber used shall be of the species and size, and in all respects, equal to or better than that specified.
13. Top chords must be sheathed or purlins provided at spacing indicated on design.
14. Bottom chords require lateral bracing at 10 ft. spacing, or less, if no ceiling is installed, unless otherwise noted.
15. Connections not shown are the responsibility of others.
16. Do not cut or alter truss member or plate without prior approval of an engineer.
17. Install and load vertically unless indicated otherwise.
18. Use of green or treated lumber may pose unacceptable environmental, health or performance risks. Consult with project engineer before use.
19. Review all portions of this design (front, back, words and pictures) before use. Reviewing pictures alone is not sufficient.
20. Design assumes manufacture in accordance with ANSI/TP1 1 Quality Criteria.
21. The design does not take into account any dynamic or other loads other than those expressly stated.

MITek®

MITtek Engineering Reference Sheet: Mill-7473 rev. 1/2/2023