

# COLUMBIA COUNTY Property Appraiser

## Parcel 35-3S-16-02309-045

### Owners

LIM CONSUELO SEACHON  
208 NW HARRIS LAKE DR  
LAKE CITY, FL 32055

GIS

Pictometry

### Parcel Summary

Location	208 NW HARRIS LAKE DR
Use Code	0100: SINGLE FAMILY
Tax District	2: COUNTY
Acreage	0.450
Township	3S
Range	16
Subdivision	FRWAY VIEW
Exemptions	01: HOMESTEAD (196.031a&b) (100%)

### Legal Description

LOT 45 FAIRWAY VIEW S/D UNIT I.

451-481, 741-2046, 742-665, LE 1431-938,  
DC 1540-674

### Working Values

	2026
Total Building	\$274,551
Total Extra Features	\$3,634
Total Market Land	\$42,000
Total Ag Land	\$0

	2026
Total Market	\$320,185
Total Assessed	\$209,934
Total Exempt	\$51,411
Total Taxable	\$158,523
SOH Diff	\$110,251

## Value History

	2025	2024	2023	2022	2021	2020
Total Building	\$273,818	\$260,534	\$241,719	\$221,653	\$189,606	\$175,869
Total Extra Features	\$3,634	\$3,634	\$3,634	\$3,634	\$3,634	\$3,634
Total Market Land	\$42,000	\$36,000	\$36,000	\$28,200	\$21,000	\$21,000
Total Ag Land	\$0	\$0	\$0	\$0	\$0	\$0
Total Market	\$319,452	\$300,168	\$281,353	\$253,487	\$214,240	\$200,503
Total Assessed	\$204,415	\$198,654	\$192,868	\$187,250	\$181,796	\$179,286
Total Exempt	\$50,722	\$50,000	\$50,000	\$50,000	\$50,000	\$50,000
Total Taxable	\$153,693	\$148,654	\$142,868	\$137,250	\$131,796	\$129,286
SOH Diff	\$115,037	\$101,514	\$88,485	\$66,237	\$32,444	\$21,217

## Document/Transfer/Sales History

Instrument / Official Record	Date	Q/U	Reason	Type	V/I	Sale Price	Ownership
<u>LE</u> 1431/938	2021-02-24	<u>U</u>	<u>14</u>	LIFE ESTATE DEED	Improved	\$100	Grantor: LIM OCTAVIO NAVARRO Grantee: LIM OCTAVIO NAVARRO
<u>WD</u> 0741/2046	1991-02-13	<u>Q</u>		WARRANTY DEED	Vacant	\$2,300	Grantor: DELIWALA Grantee: OCTAVIO

## Buildings

### Building # 1, Section # 1, 173426, SFR

Type	Style	Heated Sq Ft	Repl Cost New	YrBlt	Year Eff	Gross Area	Other % Dpr	Normal % Dpr	% Cond	Value
<u>0100</u>	<u>01</u>	2532	\$415,987	1991	1991	3,379	0.00%	34.00%	66.00%	\$274,551

## Structural Elements

## Sub Areas

Type	Description	Code	Details
EW	Exterior Wall	19	COMMON BRK
RS	Roof Structure	08	IRREGULAR
RC	Roof Cover	03	COMP SHNGL
IW	Interior Wall	05	DRYWALL
IF	Interior Flooring	14	CARPET
IF	Interior Flooring	08	SHT VINYL
AC	Air Conditioning	03	CENTRAL
HT	Heating Type	04	AIR DUCTED
BDR	Bedrooms	3.00	
BTH	Bathrooms	3.00	
FR	Frame	01	NONE
STR	Stories	1.	1.
AR	Architectural Type	05	CONV
COND	Condition Adjustment	03	03
KTCH	Kitchen Adjustment	01	01

Type	Gross Area	Percent of Base	Adjusted Area
<u>BAS</u>	2,532	100%	2,532
<u>FGR</u>	447	55%	246
<u>FOP</u>	49	30%	15
<u>FSP</u>	351	40%	140

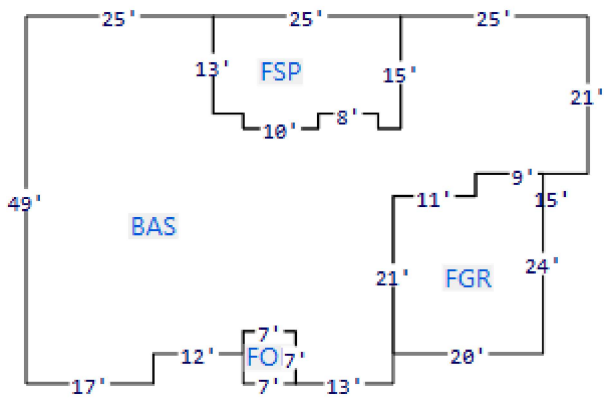

## Extra Features

Code	Description	Length	Width	Units	Unit Price	<u>AYB</u>	% Good Condition	Final Value
0166	CONC,PAVMT	90	15	1350.00	\$1.40	0	100%	\$1,890
0190	FPLC PF			1.00	\$1,200.00	0	100%	\$1,200
0166	CONC,PAVMT			272.00	\$2.00	1993	100%	\$544

## Land Lines

Code	Description	Zone	Front	Depth	Units	Rate/Unit	Acreage	Total Adj	Value
0140	SFR GOLF	00	.00	.00	1.00	\$35,000.00/ <u>LT</u>	0.45	1.20	\$42,000

## Personal Property

None

## Permits

Date	Permit	Type	Status	Description
Jan 23, 2007	25387	MAINT/ALTR	COMPLETED	MAINT/ALTR

## TRIM Notices

2025

2024

2023

## Disclaimer

All parcel data on this page is for use by the Columbia County Assessor for assessment purposes only. The summary data on this page may not be a complete representation of the parcel or of the improvements thereon. Building information, including unit counts and number of permitted units, should be verified with the appropriate building and planning agencies. Zoning information should be verified with the appropriate planning agency. All parcels are reappraised each year. This is a true and accurate copy of the records of the Columbia County Assessor's Office as of May 11, 2026.