

COLUMBIA COUNTY Property Appraiser

Parcel 09-3S-16-02049-119

Owners

RICHARDSON JAMES V
RICHARDSON ANDREA M
169 NW DALTON GLN
LAKE CITY, FL 32055

Parcel Summary

Location	169 NW DALTON GLN
Use Code	0100: SINGLE FAMILY
Tax District	3: COUNTY
Acreage	5.010
Township	3S
Range	16
Subdivision	ROLNG OAKS
Exemptions	01: HOMESTEAD (196.031a&b) (100%)

Legal Description

LOT 19 ROLLING OAKS S/D.

734-429, 774-2254, 806-346, 886-571,
890-870, 919-1272, LE 1555-2057

Working Values

	2026
Total Building	\$197,320
Total Extra Features	\$12,165
Total Market Land	\$55,000
Total Ag Land	\$0



//

	2026
Total Market	\$264,485
Total Assessed	\$185,507
Total Exempt	\$51,411
Total Taxable	\$134,096
SOH Diff	\$78,978

Value History

	2025	2024	2023	2022	2021	2020
Total Building	\$197,322	\$188,230	\$175,060	\$153,917	\$145,174	\$122,594
Total Extra Features	\$12,165	\$12,165	\$12,165	\$12,165	\$12,165	\$12,165
Total Market Land	\$50,000	\$45,000	\$45,000	\$45,000	\$39,000	\$39,000
Total Ag Land	\$0	\$0	\$0	\$0	\$0	\$0
Total Market	\$259,487	\$245,395	\$232,225	\$211,082	\$196,339	\$173,759
Total Assessed	\$180,630	\$175,539	\$170,426	\$165,462	\$160,643	\$158,425
Total Exempt	\$50,722	\$50,000	\$50,000	\$50,000	\$50,000	\$50,000
Total Taxable	\$129,908	\$125,539	\$120,426	\$115,462	\$110,643	\$108,425
SOH Diff	\$78,857	\$69,856	\$61,799	\$45,620	\$35,696	\$15,334

Document/Transfer/Sales History

Instrument / Official Record	Date	Q/U	Reason	Type	V/I	Sale Price	Ownership
<u>LE</u> 1555/2057	2025-12-02	<u>U</u>	14	LIFE ESTATE DEED	Improved	\$100	Grantor: RICHARDSON JAMES VINCENT Grantee: RICHARDSON JAMES VINCENT (ENH LIFE EST)
<u>WD</u> 0919/1272	2001-01-31	<u>Q</u>		WARRANTY DEED	Vacant	\$25,000	Grantor: LONES' Grantee: RICHARDSON'S
<u>WD</u> 0806/0346	1995-05-20	<u>Q</u>		WARRANTY DEED	Vacant	\$20,000	Grantor: KIM N BASCOMBE Grantee: DEVILLE E. & LILLIAN K LONES
<u>WD</u> 0774/2254	1993-05-14	<u>U</u>	12	WARRANTY DEED	Vacant	\$14,000	Grantor: JOHNNIE STACY JR Grantee: KIM N BASCOMBE
<u>WD</u> 0734/0429	1990-10-20	<u>Q</u>		WARRANTY DEED	Vacant	\$17,500	Grantor: PATTEN CORP Grantee: JOHNNIE STACY

Buildings

Building # 1, Section # 1, 120616, SFR

Type	Style	Heated Sq Ft	Repl Cost New	YrBlt	Year Eff	Gross Area	Other % Dpr	Normal % Dpr	% Cond	Value
0100	01	1799	\$281,886	2001	2001	3,006	0.00%	30.00%	70.00%	\$197,320

Structural Elements

Type	Description	Code	Details
EW	Exterior Wall	31	VINYL SID
RS	Roof Structure	03	GABLE/HIP
RC	Roof Cover	03	COMP SHNGL
IW	Interior Wall	05	DRYWALL
IF	Interior Flooring	14	CARPET
IF	Interior Flooring	15	HARDTILE
AC	Air Conditioning	03	CENTRAL
HT	Heating Type	04	AIR DUCTED
BDR	Bedrooms	3.00	
BTH	Bathrooms	2.00	
FR	Frame	02	WOOD FRAME
STR	Stories	1.	1.
AR	Architectural Type	05	CONV
COND	Condition Adjustment	03	03
KTCH	Kitchen Adjustment	01	01

Sub Areas

Type	Gross Area	Percent of Base	Adjusted Area
BAS	1,799	100%	1,799
FGR	574	55%	316
FOP	42	30%	13
FOP	216	30%	65
FSP	375	40%	150

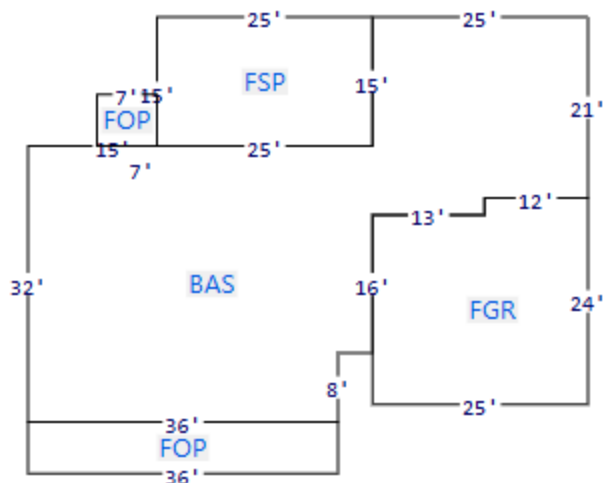

Extra Features

Code	Description	Length	Width	Units	Unit Price	AYB	% Good Condition	Final Value
0166	CONC,PAVMT			1650.00	\$1.50	2001	100%	\$2,475
0190	FPLC PF			1.00	\$1,200.00	2001	100%	\$1,200
0060	CARPORT F	33	12	396.00	\$2.50	0	100%	\$990
0070	CARPORT UF	20	30	600.00	\$2.50	2008	100%	\$1,500

Code	Description	Length	Width	Units	Unit Price	AYB	% Good Condition	Final Value
0031	BARN,MT AE	33	24	1.00	\$0.00	0	100%	\$6,000

Land Lines

Code	Description	Zone	Front	Depth	Units	Rate/Unit	Acreage	Total Adj	Value
0100	SFR	A-1	.00	.00	1.00	\$55,000.00/LT	5.01	1.00	\$55,000

Personal Property

None

Permits

Date	Permit	Type	Status	Description
Apr 5, 2021	000041639	REROOF SFR	COMPLETED	Roof Replacement or Repair
	18346	SFR	COMPLETED	SFR

TRIM Notices

2025

2024

2023

Disclaimer

All parcel data on this page is for use by the Columbia County Assessor for assessment purposes only. The summary data on this page may not be a complete representation of the parcel or of the improvements thereon. Building information, including unit counts and number of permitted units, should be verified with the appropriate building and planning agencies. Zoning information should be verified with the appropriate planning agency. All parcels are reappraised each year. This is a true and accurate copy of the records of the Columbia County Assessor's Office as of May 04, 2026.