

COLUMBIA COUNTY Property Appraiser

Parcel 36-4S-16-03382-004

Owners

FUOCO CHRISTIE L
FUOCO MICAH JAMES
118 SW SWEETBRIAR DR
LAKE CITY, FL 32024

Parcel Summary

Location	118 SW SWEETBRIAR DR
Use Code	0100: SINGLE FAMILY
Tax District	:
Acreage	1.9700
Section	36
Township	4S
Range	16
Subdivision	SOUTHWOOD
Exemptions	01: HOMESTEAD (196.031a&b) (100%)

Legal Description

LOT 4 SOUTHWOOD ACRES S/D UNIT 4.

ORB 338-494, 653-639. WD 1016-163, CT 1275-1311,
WD 1283-1190, WD 1323-2715,

Working Values

	2026
Total Building	\$374,986
Total Extra Features	\$60,726
Total Market Land	\$35,460



	2026
Total Ag Land	\$0
Total Market	\$471,172
Total Assessed	\$335,442
Total Exempt	\$50,722
Total Taxable	\$284,720
SOH Diff	\$135,730

Value History

	2025	2024	2023	2022	2021	2020	2019
Total Building	\$380,583	\$362,040	\$335,808	\$307,869	\$289,633	\$244,017	\$228,034
Total Extra Features	\$64,156	\$67,586	\$70,158	\$66,483	\$47,128	\$48,059	\$49,921
Total Market Land	\$35,460	\$29,550	\$29,550	\$29,550	\$25,413	\$25,392	\$25,392
Total Ag Land	\$0	\$0	\$0	\$0	\$0	\$0	\$0
Total Market	\$480,199	\$459,176	\$435,516	\$403,902	\$362,174	\$317,468	\$303,347
Total Assessed	\$325,672	\$316,494	\$307,276	\$298,326	\$289,637	\$285,638	\$279,216
Total Exempt	\$50,722	\$50,000	\$50,000	\$50,000	\$50,000	\$50,000	\$50,000
Total Taxable	\$274,950	\$266,494	\$257,276	\$248,326	\$239,637	\$235,638	\$229,216
SOH Diff	\$154,527	\$142,682	\$128,240	\$105,576	\$72,537	\$31,830	\$24,131

Document/Transfer/Sales History

Instrument / Official Record	Date	Q/U	Reason	Type	V/I	Sale Price	Ownership
WD 1323/2715	2016-10-14	Q	01	WARRANTY DEED	Improved	\$339,000	Grantor: BILLIE L VINCENT Grantee: CHRISTIE L FUOCO
WD 1283/1190	2014-10-21	U	12	WARRANTY DEED	Improved	\$262,500	Grantor: FIRST FEDERAL BANK OF FLORIDA Grantee: BILLIE L VINCENT
CT 1275/1311	2014-06-02	U	18	CERTIFICATE OF TITLE	Improved	\$100	Grantor: CLERK OF COURT (CURRY) Grantee: FIRST FEDERAL BANK OF AMERICA
WD 1016/0163	2004-05-14	U	07	WARRANTY DEED	Improved	\$258,000	Grantor: BRIAN & PETRA JOHNSON

Instrument / Official Record	Date	Q/U	Reason	Type	V/I	Sale Price	Ownership
							Grantee: CHRISTOPHER & HEATHER CURRY
<u>WD</u> 0653/0639	1988-05-27	<u>Q</u>		WARRANTY DEED	Vacant	\$8,500	Grantor: CAIN ROGER & Grantee: JOHNSON BRIAN B &

Buildings

Building # 1, Section # 1, 240674, SFR

Type	Model	Heated Area	Gross Area	Repl Cost New	YrBlt	Year Eff	Other % Dpr	Normal % Dpr	% Cond	Value
<u>0100</u>	<u>01</u>	3202	5095	\$559,681	1992	1992	0.00%	33.00%	67.00%	\$374,986

Structural Elements

Type	Description	Code	Details
EW	Exterior Wall	19	COMMON BRK
RS	Roof Structure	08	IRREGULAR
RC	Roof Cover	03	COMP SHNGL
IW	Interior Wall	05	DRYWALL
IF	Interior Flooring	12	HARDWOOD
IF	Interior Flooring	15	HARDTILE
AC	Air Conditioning	03	CENTRAL
HT	Heating Type	04	AIR DUCTED
BDR	Bedrooms	3.00	
BTH	Bathrooms	3.00	
FR	Frame		
STR	Stories	1.	1.
AR	Architectual Type	05	CONV
COND	Condition Adjustment	03	03
KTCH	Kitchen Adjustment	02	02

Sub Areas

Type	Gross Area	Percent of Base	Adjusted Area
<u>BAS</u>	478	100%	478
<u>BAS</u>	2,724	100%	2,724
<u>FGR</u>	600	55%	330
<u>FOP</u>	298	30%	89
<u>PTO</u>	275	5%	14
<u>PTO</u>	720	5%	36

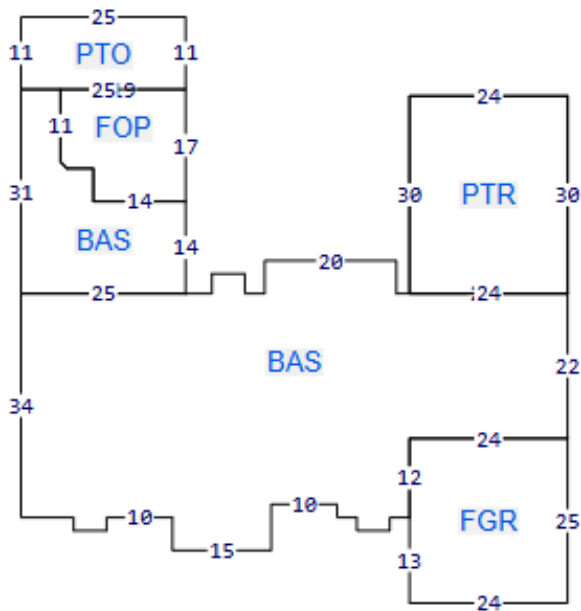

Extra Features

Code	Description	Length	Width	Units	Unit Price	AYB	% Good Condition	Final Value
0180	FPLC 1STRY			1.00	\$2,000.00	0	100%	\$2,000
0166	CONC,PAVMT	45	24	1080.00	\$2.00	1993	100%	\$2,160
0280	POOL R/CON	25	49	1225.00	\$70.00	2004	43%	\$36,873
0166	CONC,PAVMT			4030.00	\$2.00	2004	100%	\$8,060
0169	FENCE/WOOD			208.00	\$15.50	2009	100%	\$3,224
0166	CONC,PAVMT	18	18	324.00	\$2.25	2009	100%	\$729
0210	GARAGE U	20	24	480.00	\$16.00	2009	100%	\$7,680

Land Lines

Code	Description	Zone	Front	Depth	Units	Rate/Unit	Acreage	Total Adj	Value
0100	SFR	A-1	.00	.00	1.97	\$18,000.00/AC	1.97	1.00	\$35,460

Personal Property

None

Permits

Date	Permit	Type	Status	Description
Nov 4, 2024	000051357	REROOF SFR	COMPLETED	Roof Replacement or Repair
Nov 4, 2024	000051359	REROOF SFR	COMPLETED	Roof Replacement or Repair
	21955	POOL	COMPLETED	POOL
	21923	ADDN SFR	COMPLETED	ADDN SFR

TRIM Notices

2025

2024

2023

Disclaimer

All parcel data on this page is for use by the Columbia County Assessor for assessment purposes only. The summary data on this page may not be a complete representation of the parcel or of the improvements thereon. Building information, including unit counts and number of permitted units, should be verified with the appropriate building and planning agencies. Zoning information should be verified with the appropriate planning agency. All parcels are reappraised each year. This is a true and accurate copy of the records of the Columbia County Assessor's Office as of November 10, 2025.

Copyright © 2022 Columbia County. All rights reserved.
