



Lumber design values are in accordance with ANSI/TPI 1 section 6.3
These truss designs rely on lumber values established by others.

RE: 5240843 -

MiTek, Inc.
16023 Swingley Ridge Rd.
Chesterfield, MO 63017
314.434.1200

Site Information:

Customer Info: DWC CONTRACTING Project Name: Spec Hse Model: Custom
Lot/Block: 97 Subdivision: Emerald Cove
Address: TBD, N/A
City: Lake City, State: FL

Name Address and License # of Structural Engineer of Record, if there is one, for the building.

Name: License #:
Address:
City: State:

General Truss Engineering Criteria & Design Loads (Individual Truss Design Drawings Show Special Loading Conditions):

Design Code: FBC2023/TPI2014 Design Program: MiTek 20/20 8.8
Wind Code: ASCE 7-22 Wind Speed: 130 mph
Roof Load: 40.0 psf Floor Load: N/A psf

This package includes 36 individual, Truss Design Drawings and 0 Additional Drawings.
With my seal affixed to this sheet, I hereby certify that I am the Truss Design Engineer and this index sheet conforms to 61G15-31.003, section 5 of the Florida Board of Professional Engineers Rules.

No.	Seal#	Truss Name	Date	No.	Seal#	Truss Name	Date
1	T40398674	CJ01	3/10/26	15	T40398688	HJ03	3/10/26
2	T40398675	CJ02	3/10/26	16	T40398689	HJ04	3/10/26
3	T40398676	CJ02A	3/10/26	17	T40398690	T03	3/10/26
4	T40398677	CJ03	3/10/26	18	T40398691	T03G	3/10/26
5	T40398678	CJ03A	3/10/26	19	T40398692	T04	3/10/26
6	T40398679	CJ04	3/10/26	20	T40398693	T05	3/10/26
7	T40398680	CJ05	3/10/26	21	T40398694	T06	3/10/26
8	T40398681	EJ01	3/10/26	22	T40398695	T07	3/10/26
9	T40398682	EJ02	3/10/26	23	T40398696	T08	3/10/26
10	T40398683	EJ03	3/10/26	24	T40398697	T09	3/10/26
11	T40398684	EJ04	3/10/26	25	T40398698	T10	3/10/26
12	T40398685	EJ05	3/10/26	26	T40398699	T11	3/10/26
13	T40398686	HJ01	3/10/26	27	T40398700	T12	3/10/26
14	T40398687	HJ02	3/10/26	28	T40398701	T13	3/10/26

This item has been digitally signed and sealed by ORegan, Philip, PE on the date adjacent to the seal.
Printed copies of this document are not considered signed and sealed and the signature must be verified on any electronic copies

The truss drawing(s) referenced above have been prepared by
MiTek USA, Inc. under my direct supervision based on the parameters
provided by Builders FirstSource-Lake City, FL.

Truss Design Engineer's Name: ORegan, Philip
My license renewal date for the state of Florida is February 28, 2027.

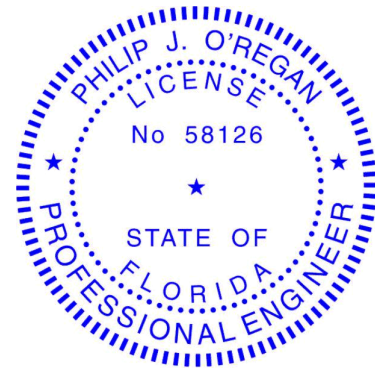

Philip J. O'Regan PE No.58126
MiTek Inc. DBA MiTek USA FL Cert 6634
16023 Swingley Ridge Rd. Chesterfield, MO 63017
Date:

IMPORTANT NOTE: The seal on these truss component designs is a certification that the engineer named is licensed in the jurisdiction(s) identified and that the designs comply with ANSI/TPI 1. These designs are based upon parameters shown (e.g., loads, supports, dimensions, shapes and design codes), which were given to MiTek or TRENCO. Any project specific information included is for MiTek's or TRENCO's customers file reference purpose only, and was not taken into account in the preparation of these designs. MiTek or TRENCO has not independently verified the applicability of the design parameters or the designs for any particular building. Before use, the building designer should verify applicability of design parameters and properly incorporate these designs into the overall building design per ANSI/TPI 1, Chapter 2.

March 10,2026



RE: 5240843 -

MiTek, Inc.
16023 Swingley Ridge Rd.
Chesterfield, MO 63017
314.434.1200

Site Information:

Customer Info: DWC CONTRACTING Project Name: Spec Hse Model: Custom
Lot/Block: 97 Subdivision: Emerald Cove
Address: TBD, N/A
City: Lake City, State: FL

No.	Seal#	Truss Name	Date
29	T40398702	T14	3/10/26
30	T40398703	T15	3/10/26
31	T40398704	T16	3/10/26
32	T40398705	T17	3/10/26
33	T40398706	T18	3/10/26
34	T40398707	T19	3/10/26
35	T40398708	T20	3/10/26
36	T40398709	T21	3/10/26

Job	Truss	Truss Type	Qty	Ply	Job Reference (optional)	T40398674
5240843	CJ01	Jack-Open	12	1		

Builders FirstSource (Lake City,FL), Lake City, FL - 32055,

Run: 8.83 S Jan 22 2026 Print: 8.830 S Jan 22 2026 MiTek Industries, Inc. Mon Mar 09 14:41:35
ID:vU7nDT107ZtscsUlkwq6GzrvJ?-RfC?PsB70Hq3NSgPqnL8w3uITXbGKWRCDoi7J4zJC?f

Page: 1

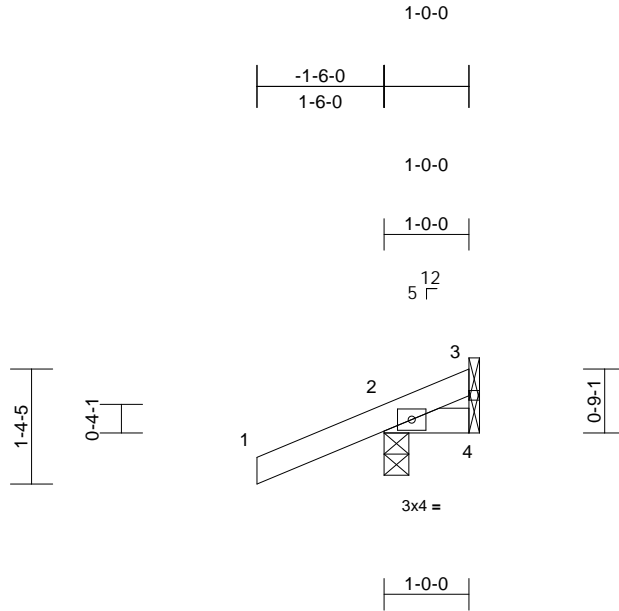

Scale = 1:27.2

Loading	(psf)	Spacing	2-0-0	CSI	DEFL	in	(loc)	l/defl	L/d	PLATES	GRIP	
TCLL (roof)	20.0	Plate Grip DOL	1.25	TC	0.15	Vert(LL)	0.00	7	>999	240	MT20	244/190
TCDL	10.0	Lumber DOL	1.25	BC	0.03	Vert(CT)	0.00	7	>999	180		
BCLL	0.0*	Rep Stress Incr	YES	WB	0.00	Horz(CT)	0.00	4	n/a	n/a		
BCDL	10.0	Code	FBC2023/TPI2014	Matrix-MP							Weight: 6 lb	FT = 20%

LUMBER

TOP CHORD 2x4 SP No.2
BOT CHORD 2x4 SP No.2

6) Provide mechanical connection (by others) of truss to bearing plate capable of withstanding 105 lb uplift at joint 2, 23 lb uplift at joint 4 and 6 lb uplift at joint 3.

BRACING

TOP CHORD Structural wood sheathing directly applied or 1-0-0 oc purlins.
BOT CHORD Rigid ceiling directly applied or 10-0-0 oc bracing.

LOAD CASE(S) Standard

REACTIONS

(size) 2=0-3-8, 3= Mechanical, 4= Mechanical
Max Horiz 2=37 (LC 8)
Max Uplift 2=-105 (LC 8), 3=-6 (LC 1), 4=-23 (LC 1)
Max Grav 2=198 (LC 1), 3=8 (LC 8), 4=17 (LC 8)

FORCES

(lb) - Maximum Compression/Maximum Tension

TOP CHORD 1-2=0/35, 2-3=-62/43
BOT CHORD 2-4=-47/67

NOTES

- 1) Wind: ASCE 7-22; Vult=130mph (3-second gust) Vasd=101mph; TCDL=4.2psf; BCDL=3.0psf; h=18ft; Cat. II; Exp B; Enclosed; MWFRS (envelope) exterior (2) zone and C-C Zone3 zone; porch left and right exposed;C-C for members and forces & MWFRS for reactions shown; Lumber DOL=1.60 plate grip DOL=1.60
- 2) Building Designer / Project engineer responsible for verifying applied roof live load shown covers rain loading requirements specific to the use of this truss component.
- 3) This truss has been designed for a 10.0 psf bottom chord live load nonconcurrent with any other live loads.
- 4) * This truss has been designed for a live load of 20.0psf on the bottom chord in all areas where a rectangle 3-06-00 tall by 2-00-00 wide will fit between the bottom chord and any other members.
- 5) Refer to girder(s) for truss to truss connections.

This item has been digitally signed and sealed by O'Regan, Philip, PE on the date indicated here. Printed copies of this document are not considered signed and sealed and the signature must be verified on any electronic copies.

Philip J. O'Regan PE No.58126
MiTek Inc. DBA MiTek USA FL Cert 6634
16023 Swingley Ridge Rd. Chesterfield, MO 63017
Date:

March 10,2026

WARNING - Verify design parameters and READ NOTES ON THIS AND INCLUDED MITEK REFERENCE PAGE MII-7473 rev. 1/2/2023 BEFORE USE.

Design valid for use only with MiTek® connectors. This design is based only upon parameters shown, and is for an individual building component, not a truss system. Before use, the building designer must verify the applicability of design parameters and properly incorporate this design into the overall building design. Bracing indicated is to prevent buckling of individual truss web and/or chord members only. Additional temporary and permanent bracing is always required for stability and to prevent collapse with possible personal injury and property damage. For general guidance regarding the fabrication, storage, delivery, erection and bracing of trusses and truss systems, see **ANSI/TPI1 Quality Criteria and DSB-22** available from Truss Plate Institute (www.tpinst.org) and **BCSI Building Component Safety Information** available from the Structural Building Component Association (www.sbcsccomponents.com)

MiTek®

16023 Swingley Ridge Rd.
Chesterfield, MO 63017
314.434.1200 / MiTek-US.com

Job 5240843	Truss CJ02	Truss Type Jack-Open	Qty 9	Ply 1	Job Reference (optional) T40398675
----------------	---------------	-------------------------	----------	----------	---------------------------------------

Builders FirstSource (Lake City,FL), Lake City, FL - 32055,

Run: 8.83 S Jan 22 2026 Print: 8.830 S Jan 22 2026 MiTek Industries, Inc. Mon Mar 09 14:41:36
ID:KKKLQJGYPI00x0bv8HWwUzvnvh-RfC?PsB70Hq3NSgPqnL8w3uITXbGKWrCdoi7J4zJC?f

Page: 1

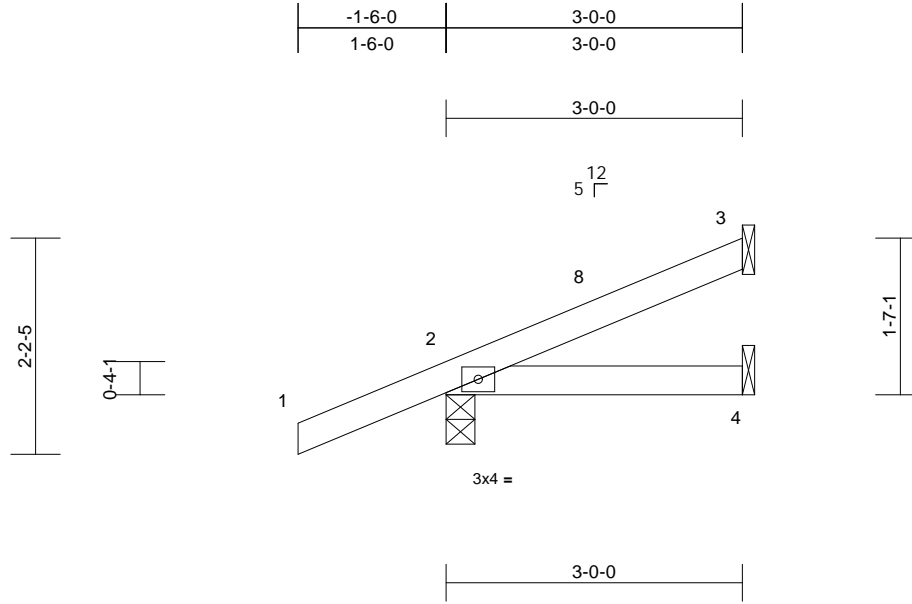

Loading	(psf)	Spacing	2-0-0	CSI	DEFL	in	(loc)	l/defl	L/d	PLATES	GRIP	
TCLL (roof)	20.0	Plate Grip DOL	1.25	TC	0.15	Vert(LL)	0.00	4-7	>999	240	MT20	244/190
TCDL	10.0	Lumber DOL	1.25	BC	0.07	Vert(CT)	-0.01	4-7	>999	180		
BCLL	0.0*	Rep Stress Incr	YES	WB	0.00	Horz(CT)	0.00	3	n/a	n/a		
BCDL	10.0	Code	FBC2023/TPI2014	Matrix-MP							Weight: 12 lb	FT = 20%

LUMBER
TOP CHORD 2x4 SP No.2
BOT CHORD 2x4 SP No.2

BRACING
TOP CHORD Structural wood sheathing directly applied or 3-0-0 oc purlins.
BOT CHORD Rigid ceiling directly applied or 10-0-0 oc bracing.

REACTIONS (size) 2=0-3-8, 3= Mechanical, 4= Mechanical
Max Horiz 2=68 (LC 12)
Max Uplift 2=-102 (LC 8), 3=-36 (LC 12), 4=-19 (LC 9)
Max Grav 2=230 (LC 1), 3=64 (LC 1), 4=50 (LC 3)

FORCES (lb) - Maximum Compression/Maximum Tension
TOP CHORD 1-2=0/35, 2-3=-75/32
BOT CHORD 2-4=-31/57

6) Provide mechanical connection (by others) of truss to bearing plate capable of withstanding 36 lb uplift at joint 3, 102 lb uplift at joint 2 and 19 lb uplift at joint 4.

LOAD CASE(S) Standard

- NOTES**
- 1) Wind: ASCE 7-22; Vult=130mph (3-second gust) Vasd=101mph; TCDL=4.2psf; BCDL=3.0psf; h=18ft; Cat. II; Exp B; Enclosed; MWFRS (envelope) exterior (2) zone and C-C Zone3 -1-6-0 to 1-6-0, Zone1 1-6-0 to 2-11-4 zone; porch left and right exposed; C-C for members and forces & MWFRS for reactions shown; Lumber DOL=1.60 plate grip DOL=1.60
 - 2) Building Designer / Project engineer responsible for verifying applied roof live load shown covers rain loading requirements specific to the use of this truss component.
 - 3) This truss has been designed for a 10.0 psf bottom chord live load nonconcurrent with any other live loads.
 - 4) * This truss has been designed for a live load of 20.0psf on the bottom chord in all areas where a rectangle 3-06-00 tall by 2-00-00 wide will fit between the bottom chord and any other members.
 - 5) Refer to girder(s) for truss to truss connections.

This item has been digitally signed and sealed by ORegan, Philip, PE on the date indicated here. Printed copies of this document are not considered signed and sealed and the signature must be verified on any electronic copies.

Philip J. O'Regan PE No.58126
MiTek Inc. DBA MiTek USA FL Cert 6634
16023 Swingley Ridge Rd. Chesterfield, MO 63017
Date:

March 10,2026

WARNING - Verify design parameters and READ NOTES ON THIS AND INCLUDED MITEK REFERENCE PAGE MII-7473 rev. 1/2/2023 BEFORE USE.

Design valid for use only with MiTek® connectors. This design is based only upon parameters shown, and is for an individual building component, not a truss system. Before use, the building designer must verify the applicability of design parameters and properly incorporate this design into the overall building design. Bracing indicated is to prevent buckling of individual truss web and/or chord members only. Additional temporary and permanent bracing is always required for stability and to prevent collapse with possible personal injury and property damage. For general guidance regarding the fabrication, storage, delivery, erection and bracing of trusses and truss systems, see **ANSI/TPI1 Quality Criteria and DSB-22** available from Truss Plate Institute (www.tpinst.org) and **BCSI Building Component Safety Information** available from the Structural Building Component Association (www.sbcsccomponents.com)

MiTek®

16023 Swingley Ridge Rd.
Chesterfield, MO 63017
314.434.1200 / MiTek-US.com

Job 5240843	Truss CJ02A	Truss Type Jack-Open	Qty 1	Ply 1	Job Reference (optional) T40398676
----------------	----------------	-------------------------	----------	----------	---------------------------------------

Builders FirstSource (Lake City,FL), Lake City, FL - 32055,

Run: 8.83 S Jan 22 2026 Print: 8.830 S Jan 22 2026 MiTek Industries, Inc. Mon Mar 09 14:41:36

Page: 1

ID:MGusvri?feBN8VeCMM4btfznuul-RFC?PsB70Hq3NSgPqnL8w3uITXbGKWrcDoi7J4zJC?f

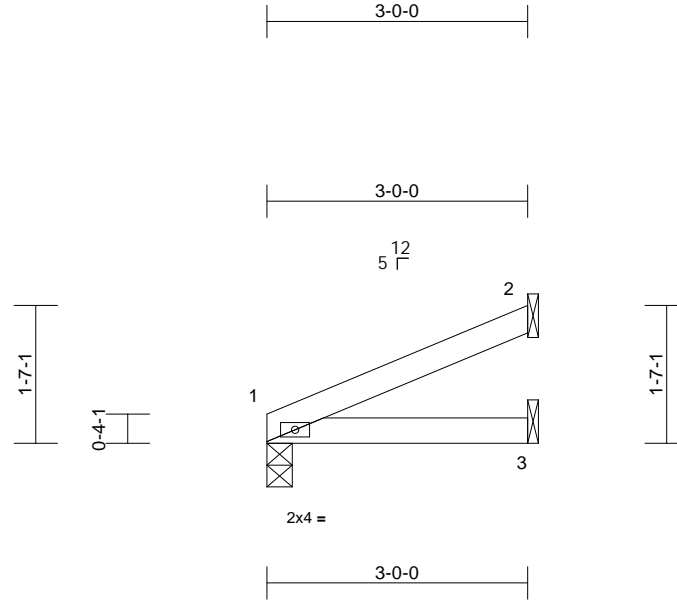

Scale = 1:26.5

Loading	(psf)	Spacing	2-0-0	CSI	DEFL	in	(loc)	l/defl	L/d	PLATES	GRIP	
TCLL (roof)	20.0	Plate Grip DOL	1.25	TC	0.10	Vert(LL)	0.00	3-6	>999	240	MT20	244/190
TCDL	10.0	Lumber DOL	1.25	BC	0.10	Vert(CT)	-0.01	3-6	>999	180		
BCLL	0.0*	Rep Stress Incr	YES	WB	0.00	Horz(CT)	0.00	1	n/a	n/a		
BCDL	10.0	Code	FBC2023/TPI2014	Matrix-MP							Weight: 9 lb	FT = 20%

LUMBER

TOP CHORD 2x4 SP No.2
BOT CHORD 2x4 SP No.2

BRACING

TOP CHORD Structural wood sheathing directly applied or 3-0-0 oc purlins.
BOT CHORD Rigid ceiling directly applied or 10-0-0 oc bracing.

REACTIONS

(size) 1=0-3-8, 2= Mechanical, 3= Mechanical
Max Horiz 1=47 (LC 12)
Max Uplift 1=-25 (LC 12), 2=-41 (LC 12), 3=-5 (LC 12)
Max Grav 1=118 (LC 1), 2=75 (LC 1), 3=54 (LC 3)

FORCES

(lb) - Maximum Compression/Maximum Tension
TOP CHORD 1-2=-58/24
BOT CHORD 1-3=-42/48

NOTES

- 1) Wind: ASCE 7-22; Vult=130mph (3-second gust) Vasd=101mph; TCDL=4.2psf; BCDL=3.0psf; h=18ft; Cat. II; Exp B; Enclosed; MWFRS (envelope) exterior (2) zone and C-C Zone3 zone;C-C for members and forces & MWFRS for reactions shown; Lumber DOL=1.60 plate grip DOL=1.60
- 2) Building Designer / Project engineer responsible for verifying applied roof live load shown covers rain loading requirements specific to the use of this truss component.
- 3) This truss has been designed for a 10.0 psf bottom chord live load nonconcurrent with any other live loads.
- 4) * This truss has been designed for a live load of 20.0psf on the bottom chord in all areas where a rectangle 3-06-00 tall by 2-00-00 wide will fit between the bottom chord and any other members.
- 5) Refer to girder(s) for truss to truss connections.
- 6) Provide mechanical connection (by others) of truss to bearing plate capable of withstanding 25 lb uplift at joint 1, 41 lb uplift at joint 2 and 5 lb uplift at joint 3.

LOAD CASE(S) Standard

This item has been digitally signed and sealed by ORegan, Philip, PE on the date indicated here. Printed copies of this document are not considered signed and sealed and the signature must be verified on any electronic copies.

Philip J. O'Regan PE No.58126
MiTek Inc. DBA MiTek USA FL Cert 6634
16023 Swingley Ridge Rd. Chesterfield, MO 63017
Date:

March 10,2026

WARNING - Verify design parameters and READ NOTES ON THIS AND INCLUDED MITEK REFERENCE PAGE MII-7473 rev. 1/2/2023 BEFORE USE.

Design valid for use only with MiTek® connectors. This design is based only upon parameters shown, and is for an individual building component, not a truss system. Before use, the building designer must verify the applicability of design parameters and properly incorporate this design into the overall building design. Bracing indicated is to prevent buckling of individual truss web and/or chord members only. Additional temporary and permanent bracing is always required for stability and to prevent collapse with possible personal injury and property damage. For general guidance regarding the fabrication, storage, delivery, erection and bracing of trusses and truss systems, see **ANSI/TPI1 Quality Criteria and DSB-22** available from Truss Plate Institute (www.tpinst.org) and **BCSI Building Component Safety Information** available from the Structural Building Component Association (www.sbcsccomponents.com)

MiTek®

16023 Swingley Ridge Rd.
Chesterfield, MO 63017
314.434.1200 / MiTek-US.com

Job 5240843	Truss CJ03	Truss Type Jack-Open	Qty 3	Ply 1	Job Reference (optional) T40398677
----------------	---------------	-------------------------	----------	----------	---------------------------------------

Builders FirstSource (Lake City,FL), Lake City, FL - 32055,

Run: 8.83 S Jan 22 2026 Print: 8.830 S Jan 22 2026 MiTek Industries, Inc. Mon Mar 09 14:41:36
ID:sPIOnnTbedQlxOFgrVZGZsznvIR-RfC?PsB70Hq3NSgPqnL8w3uTXbGKWrCDoi7J4zJC?f

Page: 1

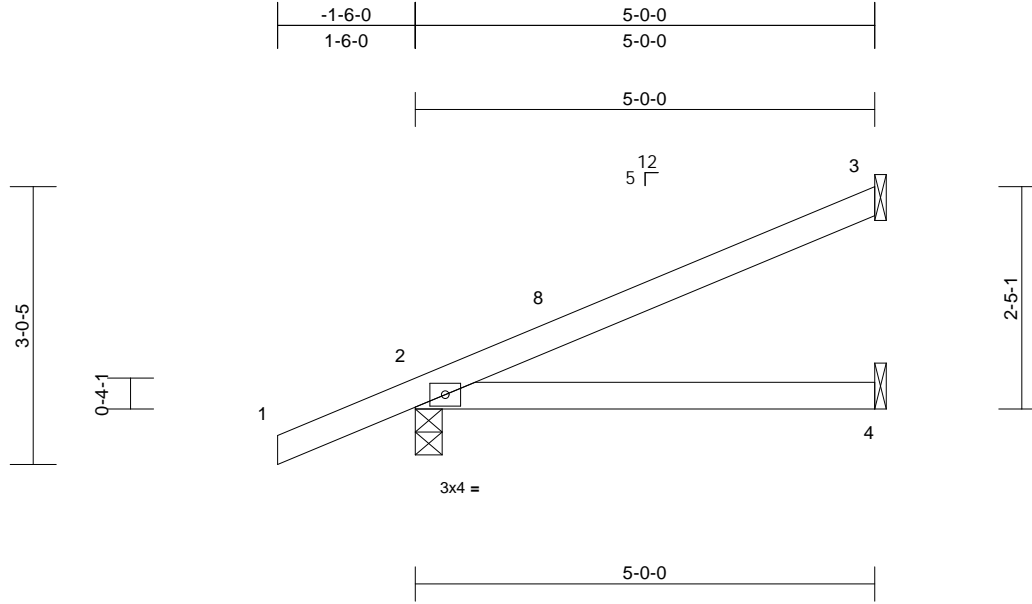

Scale = 1:25.1

Loading	(psf)	Spacing	2-0-0	CSI	DEFL	in	(loc)	l/defl	L/d	PLATES	GRIP	
TCLL (roof)	20.0	Plate Grip DOL	1.25	TC	0.30	Vert(LL)	0.05	4-7	>999	240	MT20	244/190
TCDL	10.0	Lumber DOL	1.25	BC	0.24	Vert(CT)	-0.05	4-7	>999	180		
BCLL	0.0*	Rep Stress Incr	YES	WB	0.00	Horz(CT)	0.00	3	n/a	n/a		
BCDL	10.0	Code	FBC2023/TPI2014	Matrix-MP							Weight: 18 lb	FT = 20%

LUMBER

TOP CHORD 2x4 SP No.2
BOT CHORD 2x4 SP No.2

BRACING

TOP CHORD Structural wood sheathing directly applied or 5-0-0 oc purlins.
BOT CHORD Rigid ceiling directly applied or 10-0-0 oc bracing.

REACTIONS

(size) 2=0-3-8, 3= Mechanical, 4= Mechanical
Max Horiz 2=100 (LC 12)
Max Uplift 2=-123 (LC 8), 3=-70 (LC 12), 4=-33 (LC 9)
Max Grav 2=301 (LC 1), 3=123 (LC 1), 4=89 (LC 3)

FORCES

(lb) - Maximum Compression/Maximum Tension
TOP CHORD 1-2=0/35, 2-3=-65/38
BOT CHORD 2-4=-51/46

NOTES

- 1) Wind: ASCE 7-22; Vult=130mph (3-second gust) Vasd=101mph; TCDL=4.2psf; BCDL=3.0psf; h=18ft; Cat. II; Exp B; Enclosed; MWFRS (envelope) exterior (2) zone and C-C Zone3 -1-6-0 to 1-6-0, Zone1 1-6-0 to 4-11-4 zone; porch left and right exposed;C-C for members and forces & MWFRS for reactions shown; Lumber DOL=1.60 plate grip DOL=1.60
- 2) Building Designer / Project engineer responsible for verifying applied roof live load shown covers rain loading requirements specific to the use of this truss component.
- 3) This truss has been designed for a 10.0 psf bottom chord live load nonconcurrent with any other live loads.
- 4) * This truss has been designed for a live load of 20.0psf on the bottom chord in all areas where a rectangle 3-06-00 tall by 2-00-00 wide will fit between the bottom chord and any other members.
- 5) Refer to girder(s) for truss to truss connections.

- 6) Provide mechanical connection (by others) of truss to bearing plate capable of withstanding 70 lb uplift at joint 3, 123 lb uplift at joint 2 and 33 lb uplift at joint 4.

LOAD CASE(S) Standard

This item has been digitally signed and sealed by ORegan, Philip, PE on the date indicated here. Printed copies of this document are not considered signed and sealed and the signature must be verified on any electronic copies.

Philip J. O'Regan PE No.58126
MiTek Inc. DBA MiTek USA FL Cert 6634
16023 Swingley Ridge Rd. Chesterfield, MO 63017
Date:

March 10,2026

WARNING - Verify design parameters and READ NOTES ON THIS AND INCLUDED MITEK REFERENCE PAGE MII-7473 rev. 1/2/2023 BEFORE USE.

Design valid for use only with MiTek® connectors. This design is based only upon parameters shown, and is for an individual building component, not a truss system. Before use, the building designer must verify the applicability of design parameters and properly incorporate this design into the overall building design. Bracing indicated is to prevent buckling of individual truss web and/or chord members only. Additional temporary and permanent bracing is always required for stability and to prevent collapse with possible personal injury and property damage. For general guidance regarding the fabrication, storage, delivery, erection and bracing of trusses and truss systems, see **ANSI/TPI1 Quality Criteria and DSB-22** available from Truss Plate Institute (www.tpinst.org) and **BCSI Building Component Safety Information** available from the Structural Building Component Association (www.sbcsccomponents.com)

MiTek®

16023 Swingley Ridge Rd.
Chesterfield, MO 63017
314.434.1200 / MiTek-US.com

Job 5240843	Truss CJ03A	Truss Type Jack-Open	Qty 1	Ply 1	Job Reference (optional) T40398678
----------------	----------------	-------------------------	----------	----------	---------------------------------------

Builders FirstSource (Lake City,FL), Lake City, FL - 32055,

Run: 8.83 S Jan 22 2026 Print: 8.830 S Jan 22 2026 MiTek Industries, Inc. Mon Mar 09 14:41:36

Page: 1

ID:Y6WbeoeE3oRDQaB2?6zBdOznuuO-RfC?PsB70Hq3NSgPqnL8w3uTXbGKwRCDoi7J4zJC??

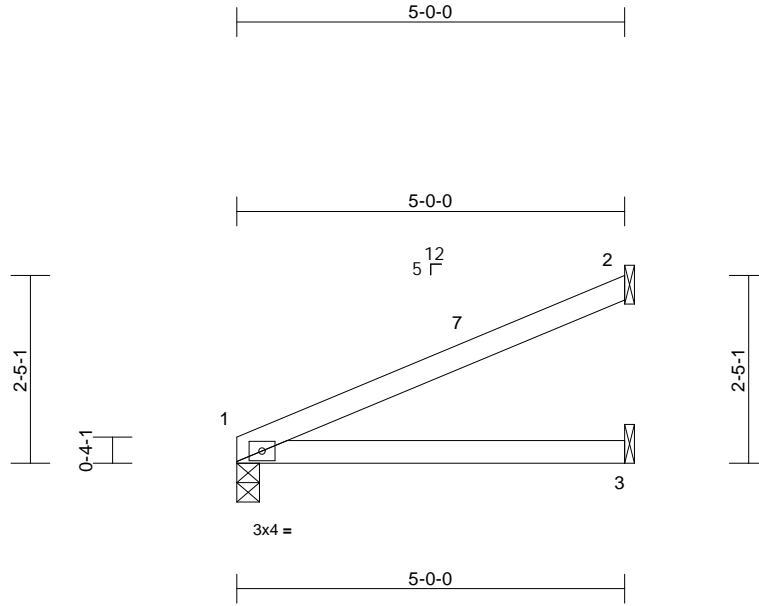

Scale = 1:29.7

Loading	(psf)	Spacing	2-0-0	CSI	DEFL	in	(loc)	l/defl	L/d	PLATES	GRIP	
TCLL (roof)	20.0	Plate Grip DOL	1.25	TC	0.33	Vert(LL)	0.03	3-6	>999	240	MT20	244/190
TCDL	10.0	Lumber DOL	1.25	BC	0.28	Vert(CT)	-0.07	3-6	>906	180		
BCLL	0.0*	Rep Stress Incr	YES	WB	0.00	Horz(CT)	0.00	1	n/a	n/a		
BCDL	10.0	Code	FBC2023/TPI2014	Matrix-MP							Weight: 16 lb	FT = 20%

LUMBER

TOP CHORD 2x4 SP No.2
BOT CHORD 2x4 SP No.2

BRACING

TOP CHORD Structural wood sheathing directly applied or 5-0-0 oc purlins.
BOT CHORD Rigid ceiling directly applied or 10-0-0 oc bracing.

REACTIONS

(size) 1=0-3-8, 2= Mechanical, 3= Mechanical
Max Horiz 1=79 (LC 12)
Max Uplift 1=-43 (LC 12), 2=-73 (LC 12), 3=-4 (LC 12)
Max Grav 1=198 (LC 1), 2=130 (LC 1), 3=91 (LC 3)

FORCES

(lb) - Maximum Compression/Maximum Tension

TOP CHORD 1-2=-96/40
BOT CHORD 1-3=-74/88

NOTES

- 1) Wind: ASCE 7-22; Vult=130mph (3-second gust) Vasd=101mph; TCDL=4.2psf; BCDL=3.0psf; h=18ft; Cat. II; Exp B; Enclosed; MWFRS (envelope) exterior (2) zone and C-C Zone3 0-0-0 to 3-0-0, Zone1 3-0-0 to 4-11-4 zone;C-C for members and forces & MWFRS for reactions shown; Lumber DOL=1.60 plate grip DOL=1.60
- 2) Building Designer / Project engineer responsible for verifying applied roof live load shown covers rain loading requirements specific to the use of this truss component.
- 3) This truss has been designed for a 10.0 psf bottom chord live load nonconcurrent with any other live loads.
- 4) * This truss has been designed for a live load of 20.0psf on the bottom chord in all areas where a rectangle 3-06-00 tall by 2-00-00 wide will fit between the bottom chord and any other members.
- 5) Refer to girder(s) for truss to truss connections.

- 6) Provide mechanical connection (by others) of truss to bearing plate capable of withstanding 43 lb uplift at joint 1, 73 lb uplift at joint 2 and 4 lb uplift at joint 3.

LOAD CASE(S) Standard

This item has been digitally signed and sealed by ORegan, Philip, PE on the date indicated here. Printed copies of this document are not considered signed and sealed and the signature must be verified on any electronic copies.

Philip J. O'Regan PE No.58126
MiTek Inc. DBA MiTek USA FL Cert 6634
16023 Swingley Ridge Rd. Chesterfield, MO 63017
Date:

March 10,2026

WARNING - Verify design parameters and READ NOTES ON THIS AND INCLUDED MITEK REFERENCE PAGE MII-7473 rev. 1/2/2023 BEFORE USE.

Design valid for use only with MiTek® connectors. This design is based only upon parameters shown, and is for an individual building component, not a truss system. Before use, the building designer must verify the applicability of design parameters and properly incorporate this design into the overall building design. Bracing indicated is to prevent buckling of individual truss web and/or chord members only. Additional temporary and permanent bracing is always required for stability and to prevent collapse with possible personal injury and property damage. For general guidance regarding the fabrication, storage, delivery, erection and bracing of trusses and truss systems, see **ANSI/TPI1 Quality Criteria and DSB-22** available from Truss Plate Institute (www.tpinst.org) and **BCSI Building Component Safety Information** available from the Structural Building Component Association (www.sbcsccomponents.com)

MiTek®

16023 Swingley Ridge Rd.
Chesterfield, MO 63017
314.434.1200 / MiTek-US.com

Job	Truss	Truss Type	Qty	Ply	Job Reference (optional)	T40398679
5240843	CJ04	Jack-Open	2	1		

Builders FirstSource (Lake City,FL), Lake City, FL - 32055,

Run: 8.83 S Jan 22 2026 Print: 8.830 S Jan 22 2026 MiTek Industries, Inc. Mon Mar 09 14:41:37
ID:fqG6g9GYi5zCcfF0FSCvI4znvDX-RfC?PsB70Hq3NSgPqnL8w3ulTXbGKWRcDoi7J4zJC?#

Page: 1

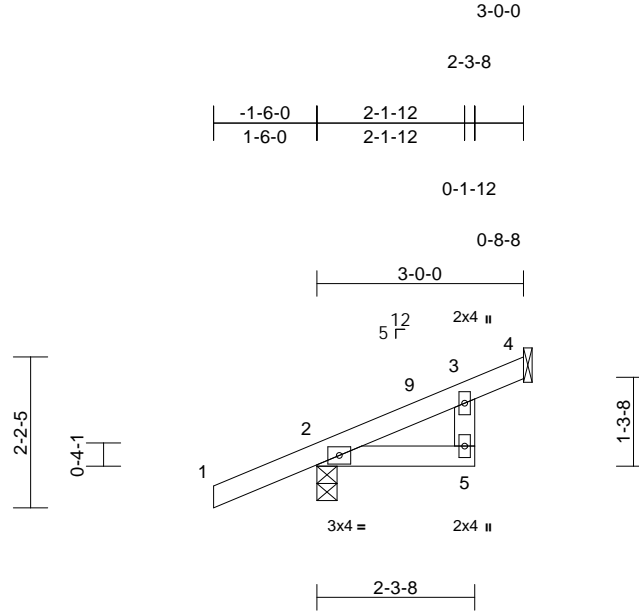

Scale = 1:33.5

Loading	(psf)	Spacing	2-0-0	CSI		DEFL	in	(loc)	l/defl	L/d	PLATES	GRIP
TCLL (roof)	20.0	Plate Grip DOL	1.25	TC	0.15	Vert(LL)	0.00	5	>999	240	MT20	244/190
TCDL	10.0	Lumber DOL	1.25	BC	0.06	Vert(CT)	-0.01	5-8	>999	180		
BCLL	0.0*	Rep Stress Incr	YES	WB	0.02	Horz(CT)	0.00	4	n/a	n/a		
BCDL	10.0	Code	FBC2023/TPI2014	Matrix-MP							Weight: 12 lb	FT = 20%

LUMBER

TOP CHORD 2x4 SP No.2
BOT CHORD 2x4 SP No.2
WEBS 2x4 SP No.3

LOAD CASE(S) Standard

BRACING

TOP CHORD Structural wood sheathing directly applied or 2-3-8 oc purlins.
BOT CHORD Rigid ceiling directly applied or 10-0-0 oc bracing.

REACTIONS (size) 2=0-3-8, 4= Mechanical

Max Horiz 2=68 (LC 12)
Max Uplift 2=-76 (LC 8), 4=-39 (LC 12)
Max Grav 2=228 (LC 1), 4=81 (LC 1)

FORCES (lb) - Maximum Compression/Maximum Tension

TOP CHORD 1-2=0/35, 2-3=-92/28, 3-4=-27/31
BOT CHORD 2-5=-31/72
WEBS 3-5=-4/42

NOTES

- 1) Wind: ASCE 7-22; Vult=130mph (3-second gust)
Vasd=101mph; TCDL=4.2psf; BCDL=3.0psf; h=18ft; Cat. II; Exp B; Enclosed; MWFRS (envelope) exterior (2) zone and C-C Zone3 -1-6-0 to 1-6-0, Zone1 1-6-0 to 2-11-4 zone;C-C for members and forces & MWFRS for reactions shown; Lumber DOL=1.60 plate grip DOL=1.60
- 2) Building Designer / Project engineer responsible for verifying applied roof live load shown covers rain loading requirements specific to the use of this truss component.
- 3) This truss has been designed for a 10.0 psf bottom chord live load nonconcurrent with any other live loads.
- 4) * This truss has been designed for a live load of 20.0psf on the bottom chord in all areas where a rectangle 3-06-00 tall by 2-00-00 wide will fit between the bottom chord and any other members.
- 5) Refer to girder(s) for truss to truss connections.
- 6) Provide mechanical connection (by others) of truss to bearing plate capable of withstanding 39 lb uplift at joint 4 and 76 lb uplift at joint 2.

This item has been digitally signed and sealed by ORegan, Philip, PE on the date indicated here. Printed copies of this document are not considered signed and sealed and the signature must be verified on any electronic copies.

Philip J. O'Regan PE No.58126
MiTek Inc. DBA MiTek USA FL Cert 6634
16023 Swingley Ridge Rd. Chesterfield, MO 63017
Date:

March 10,2026

WARNING - Verify design parameters and READ NOTES ON THIS AND INCLUDED MITEK REFERENCE PAGE MII-7473 rev. 1/2/2023 BEFORE USE.

Design valid for use only with MiTek® connectors. This design is based only upon parameters shown, and is for an individual building component, not a truss system. Before use, the building designer must verify the applicability of design parameters and properly incorporate this design into the overall building design. Bracing indicated is to prevent buckling of individual truss web and/or chord members only. Additional temporary and permanent bracing is always required for stability and to prevent collapse with possible personal injury and property damage. For general guidance regarding the fabrication, storage, delivery, erection and bracing of trusses and truss systems, see **ANSI/TPI1 Quality Criteria and DSB-22** available from Truss Plate Institute (www.tpinst.org) and **BCSI Building Component Safety Information** available from the Structural Building Component Association (www.sbcsccomponents.com)

MiTek®

16023 Swingley Ridge Rd.
Chesterfield, MO 63017
314.434.1200 / MiTek-US.com

Job 5240843	Truss CJ05	Truss Type Jack-Open	Qty 2	Ply 1	Job Reference (optional) T40398680
----------------	---------------	-------------------------	----------	----------	---------------------------------------

Builders FirstSource (Lake City,FL), Lake City, FL - 32055,

Run: 8.83 S Jan 22 2026 Print: 8.830 S Jan 22 2026 MiTek Industries, Inc. Mon Mar 09 14:41:37

Page: 1

ID:fdWbYxYcl6oPlrtoLD6rtznvFF-RfC?PsB70Hq3NSgPqnL8w3ulTXbGKWRcDoi7J4zJC?i

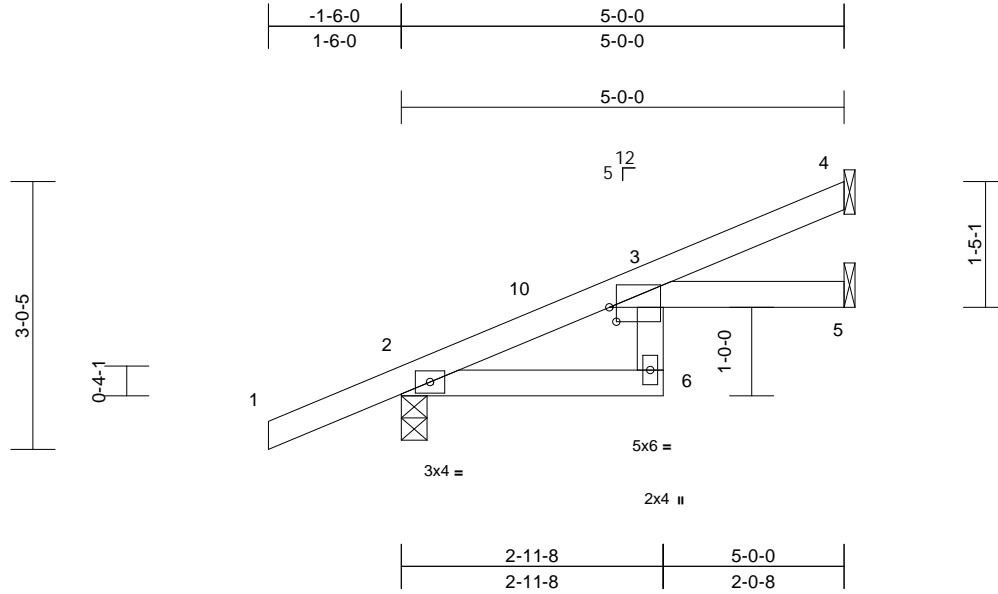

Scale = 1:26

Plate Offsets (X, Y): [3:0-0-15,0-1-15]

Loading	(psf)	Spacing	2-0-0	CSI	DEFL	in	(loc)	l/defl	L/d	PLATES	GRIP	
TCLL (roof)	20.0	Plate Grip DOL	1.25	TC	0.45	Vert(LL)	0.05	6	>999	240	MT20	244/190
TCDL	10.0	Lumber DOL	1.25	BC	0.28	Vert(CT)	-0.09	6	>696	180		
BCLL	0.0*	Rep Stress Incr	YES	WB	0.00	Horz(CT)	0.04	5	n/a	n/a		
BCDL	10.0	Code	FBC2023/TPI2014	Matrix-MR							Weight: 20 lb	FT = 20%

LUMBER

TOP CHORD 2x4 SP No.2
 BOT CHORD 2x4 SP No.2 *Except* 6-3:2x4 SP No.3

BRACING

TOP CHORD Structural wood sheathing directly applied or 5-0-0 oc purlins.
 BOT CHORD Rigid ceiling directly applied or 6-0-0 oc bracing.

REACTIONS

(size) 2=0-3-8, 4= Mechanical, 5= Mechanical
 Max Horiz 2=100 (LC 12)
 Max Uplift 2=-86 (LC 12), 4=-52 (LC 12), 5=-17 (LC 12)
 Max Grav 2=303 (LC 1), 4=108 (LC 1), 5=84 (LC 3)

FORCES

(lb) - Maximum Compression/Maximum Tension

TOP CHORD 1-2=0/35, 2-3=-105/0, 3-4=-41/36
 BOT CHORD 2-6=-31/74, 3-6=-37/95, 3-5=-4/3

NOTES

- 1) Wind: ASCE 7-22; Vult=130mph (3-second gust) Vasd=101mph; TCDL=4.2psf; BCDL=3.0psf; h=18ft; Cat. II; Exp B; Enclosed; MWFRS (envelope) exterior (2) zone and C-C Zone3 -1-6-0 to 1-6-0, Zone1 1-6-0 to 4-11-4 zone;C-C for members and forces & MWFRS for reactions shown; Lumber DOL=1.60 plate grip DOL=1.60
- 2) Building Designer / Project engineer responsible for verifying applied roof live load shown covers rain loading requirements specific to the use of this truss component.
- 3) This truss has been designed for a 10.0 psf bottom chord live load nonconcurrent with any other live loads.
- 4) * This truss has been designed for a live load of 20.0psf on the bottom chord in all areas where a rectangle 3-06-00 tall by 2-00-00 wide will fit between the bottom chord and any other members.
- 5) Refer to girder(s) for truss to truss connections.

- 6) Provide mechanical connection (by others) of truss to bearing plate capable of withstanding 52 lb uplift at joint 4, 86 lb uplift at joint 2 and 17 lb uplift at joint 5.

LOAD CASE(S) Standard

This item has been digitally signed and sealed by ORegan, Philip, PE on the date indicated here. Printed copies of this document are not considered signed and sealed and the signature must be verified on any electronic copies.

Philip J. O'Regan PE No.58126
 MiTek Inc. DBA MiTek USA FL Cert 6634
 16023 Swingley Ridge Rd. Chesterfield, MO 63017
 Date:

March 10,2026

WARNING - Verify design parameters and READ NOTES ON THIS AND INCLUDED MITEK REFERENCE PAGE MII-7473 rev. 1/2/2023 BEFORE USE.

Design valid for use only with MiTek® connectors. This design is based only upon parameters shown, and is for an individual building component, not a truss system. Before use, the building designer must verify the applicability of design parameters and properly incorporate this design into the overall building design. Bracing indicated is to prevent buckling of individual truss web and/or chord members only. Additional temporary and permanent bracing is always required for stability and to prevent collapse with possible personal injury and property damage. For general guidance regarding the fabrication, storage, delivery, erection and bracing of trusses and truss systems, see **ANSI/TPI1 Quality Criteria and DSB-22** available from Truss Plate Institute (www.tpinst.org) and **BCSI Building Component Safety Information** available from the Structural Building Component Association (www.sbcsccomponents.com)

MiTek®

16023 Swingley Ridge Rd.
 Chesterfield, MO 63017
 314.434.1200 / MiTek-US.com

Job 5240843	Truss EJ01	Truss Type Jack-Partial	Qty 14	Ply 1	Job Reference (optional) T40398681
----------------	---------------	----------------------------	-----------	----------	---------------------------------------

Builders FirstSource (Lake City,FL), Lake City, FL - 32055,

Run: 8.83 S Jan 22 2026 Print: 8.830 S Jan 22 2026 MiTek Industries, Inc. Mon Mar 09 14:41:37
ID:Lm4BXd7XNjgJtSD?NnW0dlznvGI-RfC?PsB70Hq3NSgPqnL8w3ulTXbGKWrCDoi7J4zJC?f

Page: 1

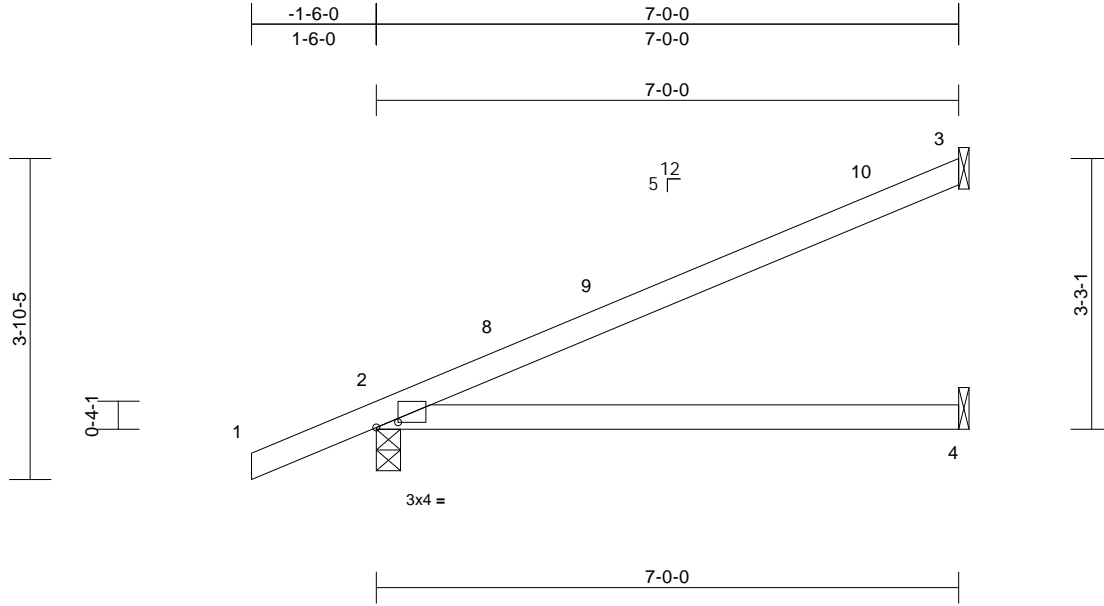

Scale = 1:27.7

Plate Offsets (X, Y): [2:0-3-2,0-0-12]

Loading	(psf)	Spacing	2-0-0	CSI	DEFL	in	(loc)	l/defl	L/d	PLATES	GRIP	
TCLL (roof)	20.0	Plate Grip DOL	1.25	TC	0.68	Vert(LL)	0.11	4-7	>777	240	MT20	244/190
TCDL	10.0	Lumber DOL	1.25	BC	0.53	Vert(CT)	-0.23	4-7	>369	180		
BCLL	0.0*	Rep Stress Incr	YES	WB	0.00	Horz(CT)	0.00	2	n/a	n/a		
BCDL	10.0	Code	FBC2023/TPI2014	Matrix-MP							Weight: 24 lb	FT = 20%

LUMBER

TOP CHORD 2x4 SP No.2
BOT CHORD 2x4 SP No.2

BRACING

TOP CHORD Structural wood sheathing directly applied or 6-0-0 oc purlins.
BOT CHORD Rigid ceiling directly applied or 10-0-0 oc bracing.

REACTIONS

(size) 2=0-3-8, 3= Mechanical, 4= Mechanical
Max Horiz 2=128 (LC 12)
Max Uplift 2=-103 (LC 12), 3=-90 (LC 12), 4=-1 (LC 12)
Max Grav 2=377 (LC 1), 3=180 (LC 1), 4=127 (LC 3)

FORCES

(lb) - Maximum Compression/Maximum Tension

TOP CHORD 1-2=0/35, 2-3=-109/55
BOT CHORD 2-4=-39/97

NOTES

- 1) Wind: ASCE 7-22; Vult=130mph (3-second gust) Vasd=101mph; TCDL=4.2psf; BCDL=3.0psf; h=18ft; Cat. II; Exp B; Enclosed; MWFRS (envelope) exterior (2) zone and C-C Zone3 -1-6-0 to 1-6-0, Zone1 1-6-0 to 6-11-4 zone;C-C for members and forces & MWFRS for reactions shown; Lumber DOL=1.60 plate grip DOL=1.60
- 2) Building Designer / Project engineer responsible for verifying applied roof live load shown covers rain loading requirements specific to the use of this truss component.
- 3) This truss has been designed for a 10.0 psf bottom chord live load nonconcurrent with any other live loads.
- 4) * This truss has been designed for a live load of 20.0psf on the bottom chord in all areas where a rectangle 3-06-00 tall by 2-00-00 wide will fit between the bottom chord and any other members.
- 5) Refer to girder(s) for truss to truss connections.

6) Provide mechanical connection (by others) of truss to bearing plate capable of withstanding 90 lb uplift at joint 3, 103 lb uplift at joint 2 and 1 lb uplift at joint 4.

LOAD CASE(S) Standard

This item has been digitally signed and sealed by ORegan, Philip, PE on the date indicated here. Printed copies of this document are not considered signed and sealed and the signature must be verified on any electronic copies.

Philip J. O'Regan PE No.58126
MiTek Inc. DBA MiTek USA FL Cert 6634
16023 Swingley Ridge Rd. Chesterfield, MO 63017
Date:

March 10,2026

WARNING - Verify design parameters and READ NOTES ON THIS AND INCLUDED MITEK REFERENCE PAGE MII-7473 rev. 1/2/2023 BEFORE USE.

Design valid for use only with MiTek® connectors. This design is based only upon parameters shown, and is for an individual building component, not a truss system. Before use, the building designer must verify the applicability of design parameters and properly incorporate this design into the overall building design. Bracing indicated is to prevent buckling of individual truss web and/or chord members only. Additional temporary and permanent bracing is always required for stability and to prevent collapse with possible personal injury and property damage. For general guidance regarding the fabrication, storage, delivery, erection and bracing of trusses and truss systems, see **ANSI/TPI1 Quality Criteria and DSB-22** available from Truss Plate Institute (www.tpinst.org) and **BCSI Building Component Safety Information** available from the Structural Building Component Association (www.sbcsccomponents.com)

MiTek®

16023 Swingley Ridge Rd.
Chesterfield, MO 63017
314.434.1200 / MiTek-US.com

Job 5240843	Truss EJ02	Truss Type Jack-Partial	Qty 3	Ply 1	Job Reference (optional)	T40398682
----------------	---------------	----------------------------	----------	----------	--------------------------	-----------

Builders FirstSource (Lake City,FL), Lake City, FL - 32055,

Run: 8.83 S Jan 22 2026 Print: 8.830 S Jan 22 2026 MiTek Industries, Inc. Mon Mar 09 14:41:37
ID:LafTE3kWN54UHcos_xMBVzrvFV-RfC?PsB70Hq3NSgPqnL8w3uTXbGKWrCD0i7J4zJC7f

Page: 1

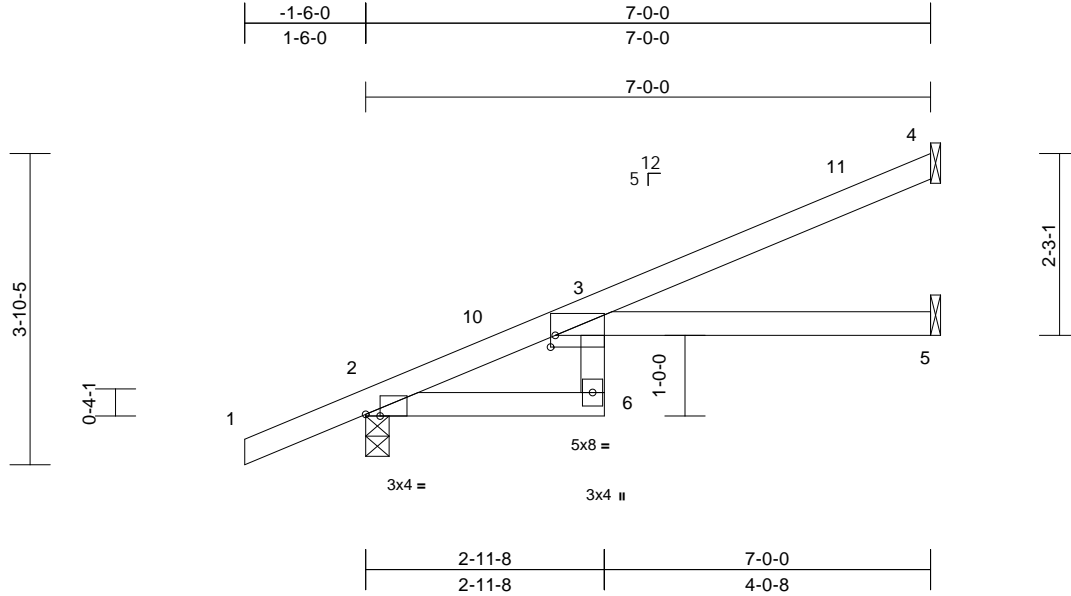

Scale = 1:28.6

Plate Offsets (X, Y): [2:0-2-2,Edge], [3:0-0-11,0-1-12]

Loading	(psf)	Spacing	2-0-0	CSI	DEFL	in	(loc)	l/defl	L/d	PLATES	GRIP	
TCLL (roof)	20.0	Plate Grip DOL	1.25	TC	0.87	Vert(LL)	0.17	6	>486	240	MT20	244/190
TCDL	10.0	Lumber DOL	1.25	BC	0.65	Vert(CT)	-0.31	6	>269	180		
BCLL	0.0*	Rep Stress Incr	YES	WB	0.00	Horz(CT)	0.13	5	n/a	n/a		
BCDL	10.0	Code	FBC2023/TPI2014	Matrix-MR							Weight: 26 lb	FT = 20%

LUMBER

TOP CHORD 2x4 SP No.2
BOT CHORD 2x4 SP No.2 *Except* 6-3:2x4 SP No.3

BRACING

TOP CHORD Structural wood sheathing directly applied or 2-2-0 oc purlins.
BOT CHORD Rigid ceiling directly applied or 6-0-0 oc bracing.

REACTIONS

(size) 2=0-3-8, 4= Mechanical, 5= Mechanical
Max Horiz 2=128 (LC 12)
Max Uplift 2=-102 (LC 12), 4=-73 (LC 12), 5=-17 (LC 12)
Max Grav 2=379 (LC 1), 4=164 (LC 1), 5=122 (LC 3)

FORCES

(lb) - Maximum Compression/Maximum Tension

TOP CHORD 1-2=0/35, 2-3=-174/0, 3-4=-59/53
BOT CHORD 2-6=-43/111, 3-6=-47/131, 3-5=-3/2

NOTES

- 1) Wind: ASCE 7-22; Vult=130mph (3-second gust) Vasd=101mph; TCDL=4.2psf; BCDL=3.0psf; h=18ft; Cat. II; Exp B; Enclosed; MWFRS (envelope) exterior (2) zone and C-C Zone3 -1-6-0 to 1-6-0, Zone1 1-6-0 to 6-11-4 zone;C-C for members and forces & MWFRS for reactions shown; Lumber DOL=1.60 plate grip DOL=1.60
- 2) Building Designer / Project engineer responsible for verifying applied roof live load shown covers rain loading requirements specific to the use of this truss component.
- 3) This truss has been designed for a 10.0 psf bottom chord live load nonconcurrent with any other live loads.
- 4) * This truss has been designed for a live load of 20.0psf on the bottom chord in all areas where a rectangle 3-06-00 tall by 2-00-00 wide will fit between the bottom chord and any other members.
- 5) Refer to girder(s) for truss to truss connections.

- 6) Provide mechanical connection (by others) of truss to bearing plate capable of withstanding 73 lb uplift at joint 4, 102 lb uplift at joint 2 and 17 lb uplift at joint 5.

LOAD CASE(S) Standard

This item has been digitally signed and sealed by ORegan, Philip, PE on the date indicated here. Printed copies of this document are not considered signed and sealed and the signature must be verified on any electronic copies.

Philip J. O'Regan PE No.58126
MiTek Inc. DBA MiTek USA FL Cert 6634
16023 Swingley Ridge Rd. Chesterfield, MO 63017
Date:

March 10,2026

WARNING - Verify design parameters and READ NOTES ON THIS AND INCLUDED MITEK REFERENCE PAGE MII-7473 rev. 1/2/2023 BEFORE USE.

Design valid for use only with MiTek® connectors. This design is based only upon parameters shown, and is for an individual building component, not a truss system. Before use, the building designer must verify the applicability of design parameters and properly incorporate this design into the overall building design. Bracing indicated is to prevent buckling of individual truss web and/or chord members only. Additional temporary and permanent bracing is always required for stability and to prevent collapse with possible personal injury and property damage. For general guidance regarding the fabrication, storage, delivery, erection and bracing of trusses and truss systems, see **ANSI/TPI1 Quality Criteria and DSB-22** available from Truss Plate Institute (www.tpinst.org) and **BCSI Building Component Safety Information** available from the Structural Building Component Association (www.sbcsccomponents.com)

MiTek®

16023 Swingley Ridge Rd.
Chesterfield, MO 63017
314.434.1200 / MiTek-US.com

Job 5240843	Truss EJ03	Truss Type Jack-Partial	Qty 2	Ply 1	Job Reference (optional) T40398683
----------------	---------------	----------------------------	----------	----------	---------------------------------------

Builders FirstSource (Lake City,FL), Lake City, FL - 32055,

Run: 8.83 S Jan 22 2026 Print: 8.830 S Jan 22 2026 MiTek Industries, Inc. Mon Mar 09 14:41:37
ID:6a4enAQCVOqmNldpLXTG81znvFv-RfC?PsB70Hq3NSgPqnL8w3uTXbGKWrCDoi7J4zJC?f

Page: 1

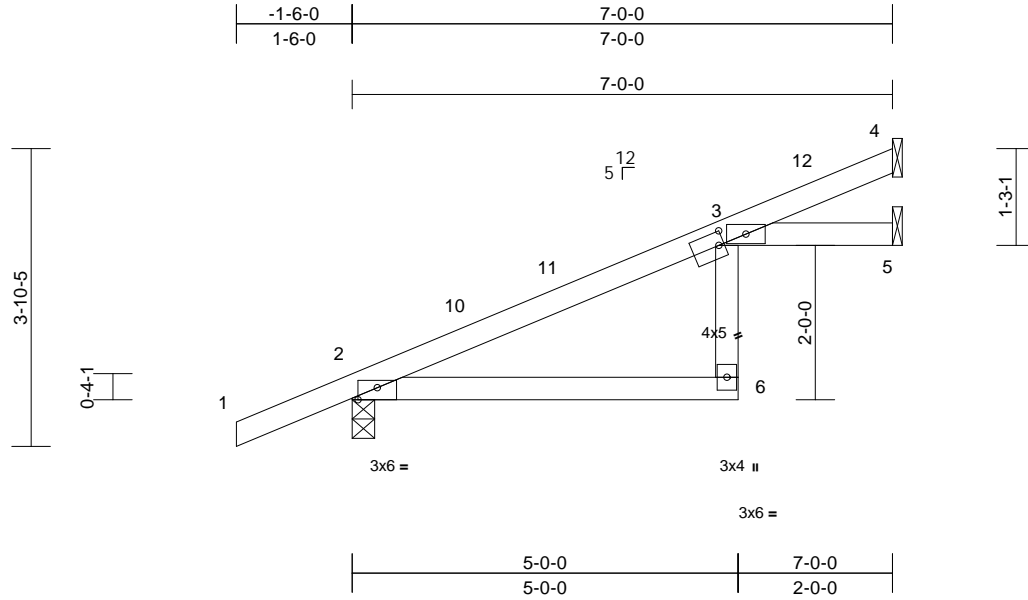

Scale = 1:29.8

Plate Offsets (X, Y): [2:0-3-0,Edge], [3:0-1-3,0-0-4], [3:0-0-13,0-2-2]

Loading	(psf)	Spacing	2-0-0	CSI	DEFL	in	(loc)	l/defl	L/d	PLATES	GRIP	
TCLL (roof)	20.0	Plate Grip DOL	1.25	TC	0.94	Vert(LL)	0.18	6	>454	240	MT20	244/190
TCDL	10.0	Lumber DOL	1.25	BC	0.52	Vert(CT)	-0.32	6	>260	180		
BCLL	0.0*	Rep Stress Incr	YES	WB	0.00	Horz(CT)	0.13	5	n/a	n/a		
BCDL	10.0	Code	FBC2023/TPI2014	Matrix-MR							Weight: 27 lb	FT = 20%

LUMBER

TOP CHORD 2x4 SP No.2
BOT CHORD 2x4 SP No.2 *Except* 6-3:2x4 SP No.3

BRACING

TOP CHORD Structural wood sheathing directly applied or 2-2-0 oc purlins.
BOT CHORD Rigid ceiling directly applied or 10-0-0 oc bracing.

REACTIONS

(size) 2=0-3-8, 4= Mechanical, 5= Mechanical
Max Horiz 2=128 (LC 12)
Max Uplift 2=-103 (LC 12), 4=-57 (LC 12), 5=-33 (LC 12)
Max Grav 2=378 (LC 1), 4=147 (LC 1), 5=122 (LC 1)

FORCES

(lb) - Maximum Compression/Maximum Tension

TOP CHORD 1-2=0/35, 2-3=-151/0, 3-4=-44/52
BOT CHORD 2-6=-46/111, 3-6=-29/139, 3-5=0/0

NOTES

- 1) Wind: ASCE 7-22; Vult=130mph (3-second gust) Vasd=101mph; TCDL=4.2psf; BCDL=3.0psf; h=18ft; Cat. II; Exp B; Enclosed; MWFRS (envelope) exterior (2) zone and C-C Zone3 -1-6-0 to 1-6-0, Zone1 1-6-0 to 6-11-4 zone;C-C for members and forces & MWFRS for reactions shown; Lumber DOL=1.60 plate grip DOL=1.60
- 2) Building Designer / Project engineer responsible for verifying applied roof live load shown covers rain loading requirements specific to the use of this truss component.
- 3) This truss has been designed for a 10.0 psf bottom chord live load nonconcurrent with any other live loads.
- 4) * This truss has been designed for a live load of 20.0psf on the bottom chord in all areas where a rectangle 3-06-00 tall by 2-00-00 wide will fit between the bottom chord and any other members.
- 5) Refer to girder(s) for truss to truss connections.

- 6) Provide mechanical connection (by others) of truss to bearing plate capable of withstanding 57 lb uplift at joint 4, 103 lb uplift at joint 2 and 33 lb uplift at joint 5.

LOAD CASE(S) Standard

This item has been digitally signed and sealed by ORegan, Philip, PE on the date indicated here. Printed copies of this document are not considered signed and sealed and the signature must be verified on any electronic copies.

Philip J. O'Regan PE No.58126
MiTek Inc. DBA MiTek USA FL Cert 6634
16023 Swingley Ridge Rd. Chesterfield, MO 63017
Date:

March 10,2026

WARNING - Verify design parameters and READ NOTES ON THIS AND INCLUDED MITEK REFERENCE PAGE MII-7473 rev. 1/2/2023 BEFORE USE.

Design valid for use only with MiTek® connectors. This design is based only upon parameters shown, and is for an individual building component, not a truss system. Before use, the building designer must verify the applicability of design parameters and properly incorporate this design into the overall building design. Bracing indicated is to prevent buckling of individual truss web and/or chord members only. Additional temporary and permanent bracing is always required for stability and to prevent collapse with possible personal injury and property damage. For general guidance regarding the fabrication, storage, delivery, erection and bracing of trusses and truss systems, see **ANSI/TPI1 Quality Criteria and DSB-22** available from Truss Plate Institute (www.tpinst.org) and **BCSI Building Component Safety Information** available from the Structural Building Component Association (www.sbcsccomponents.com)

MiTek®

16023 Swingley Ridge Rd.
Chesterfield, MO 63017
314.434.1200 / MiTek-US.com

Job 5240843	Truss EJ04	Truss Type Jack-Partial	Qty 2	Ply 1	Job Reference (optional) T40398684
----------------	---------------	----------------------------	----------	----------	---------------------------------------

Builders FirstSource (Lake City,FL), Lake City, FL - 32055,

Run: 8.83 S Jan 22 2026 Print: 8.830 S Jan 22 2026 MiTek Industries, Inc. Mon Mar 09 14:41:38
ID:0sBi?68LVXArstK20H00ITzrvCO-RFC?PsB70Hq3NSgPqnL8w3ulTXbGKWrCDoi7J4zJC?f

Page: 1

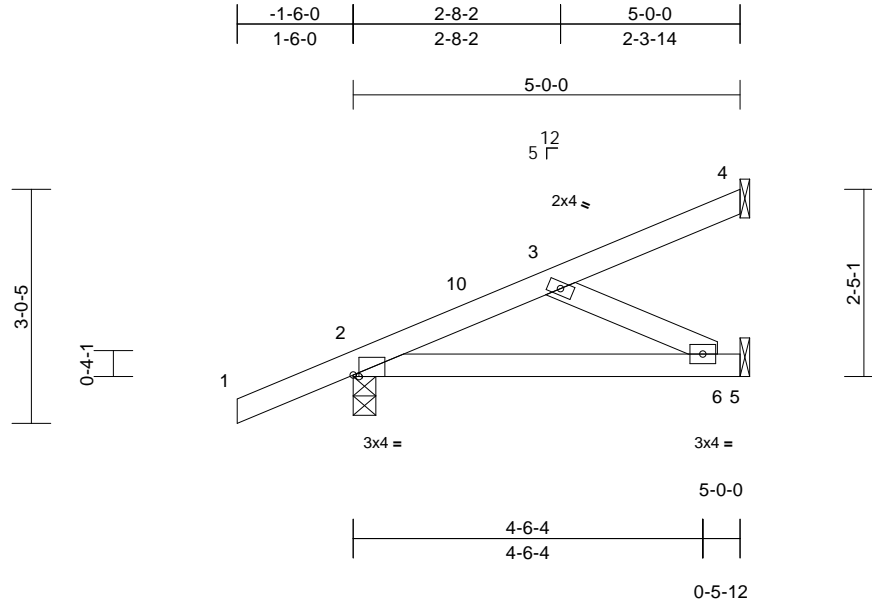

Scale = 1:29.8

Plate Offsets (X, Y): [2:0-0-14,Edge]

Loading	(psf)	Spacing	2-0-0	CSI	DEFL	in	(loc)	l/defl	L/d	PLATES	GRIP	
TCLL (roof)	20.0	Plate Grip DOL	1.25	TC	0.17	Vert(LL)	-0.02	6-9	>999	240	MT20	244/190
TCDL	10.0	Lumber DOL	1.25	BC	0.20	Vert(CT)	-0.03	6-9	>999	180		
BCLL	0.0*	Rep Stress Incr	YES	WB	0.05	Horz(CT)	0.00	5	n/a	n/a		
BCDL	10.0	Code	FBC2023/TPI2014	Matrix-MP							Weight: 22 lb	FT = 20%

LUMBER

TOP CHORD 2x4 SP No.2
BOT CHORD 2x4 SP No.2
WEBS 2x4 SP No.3

- Refer to girder(s) for truss to truss connections.
- Provide mechanical connection (by others) of truss to bearing plate capable of withstanding 39 lb uplift at joint 4, 86 lb uplift at joint 2 and 31 lb uplift at joint 5.

LOAD CASE(S) Standard

BRACING

TOP CHORD Structural wood sheathing directly applied or 5-0-0 oc purlins.
BOT CHORD Rigid ceiling directly applied or 10-0-0 oc bracing.

REACTIONS

(size) 2=0-3-8, 4= Mechanical, 5= Mechanical
Max Horiz 2=100 (LC 12)
Max Uplift 2=-86 (LC 12), 4=-39 (LC 12), 5=-31 (LC 12)
Max Grav 2=301 (LC 1), 4=59 (LC 1), 5=130 (LC 3)

FORCES

(lb) - Maximum Compression/Maximum Tension

TOP CHORD 1-2=0/35, 2-3=-217/87, 3-4=-38/17
BOT CHORD 2-6=-161/196, 5-6=0/0
WEBS 3-6=-218/179

NOTES

- Wind: ASCE 7-22; Vult=130mph (3-second gust)
Vasd=101mph; TCDL=4.2psf; BCDL=3.0psf; h=18ft; Cat. II; Exp B; Enclosed; MWFRS (envelope) exterior (2) zone and C-C Zone3 -1-6-0 to 1-6-0, Zone1 1-6-0 to 4-11-4 zone;C-C for members and forces & MWFRS for reactions shown; Lumber DOL=1.60 plate grip DOL=1.60
- Building Designer / Project engineer responsible for verifying applied roof live load shown covers rain loading requirements specific to the use of this truss component.
- This truss has been designed for a 10.0 psf bottom chord live load nonconcurrent with any other live loads.
- * This truss has been designed for a live load of 20.0psf on the bottom chord in all areas where a rectangle 3-06-00 tall by 2-00-00 wide will fit between the bottom chord and any other members.

This item has been digitally signed and sealed by ORegan, Philip, PE on the date indicated here. Printed copies of this document are not considered signed and sealed and the signature must be verified on any electronic copies.

Philip J. O'Regan PE No.58126
MiTek Inc. DBA MiTek USA FL Cert 6634
16023 Swingley Ridge Rd. Chesterfield, MO 63017
Date:

March 10,2026

WARNING - Verify design parameters and READ NOTES ON THIS AND INCLUDED MITEK REFERENCE PAGE MII-7473 rev. 1/2/2023 BEFORE USE.

Design valid for use only with MiTek® connectors. This design is based only upon parameters shown, and is for an individual building component, not a truss system. Before use, the building designer must verify the applicability of design parameters and properly incorporate this design into the overall building design. Bracing indicated is to prevent buckling of individual truss web and/or chord members only. Additional temporary and permanent bracing is always required for stability and to prevent collapse with possible personal injury and property damage. For general guidance regarding the fabrication, storage, delivery, erection and bracing of trusses and truss systems, see **ANSI/TPI1 Quality Criteria and DSB-22** available from Truss Plate Institute (www.tpinst.org) and **BCSI Building Component Safety Information** available from the Structural Building Component Association (www.sbcsccomponents.com)

MiTek®

16023 Swingley Ridge Rd.
Chesterfield, MO 63017
314.434.1200 / MiTek-US.com

Job 5240843	Truss EJ05	Truss Type Jack-Open	Qty 1	Ply 1	Job Reference (optional) T40398685
----------------	---------------	-------------------------	----------	----------	---------------------------------------

Builders FirstSource (Lake City,FL), Lake City, FL - 32055,

Run: 8.83 S Jan 22 2026 Print: 8.830 S Jan 22 2026 MiTek Industries, Inc. Mon Mar 09 14:41:38
ID:Vj0xluc7pJw2NE9zY1n42OznvIF-RfC?PsB70Hq3NSgPqnL8w3ulTXbGKWrCDoi7J4zJC?

Page: 1

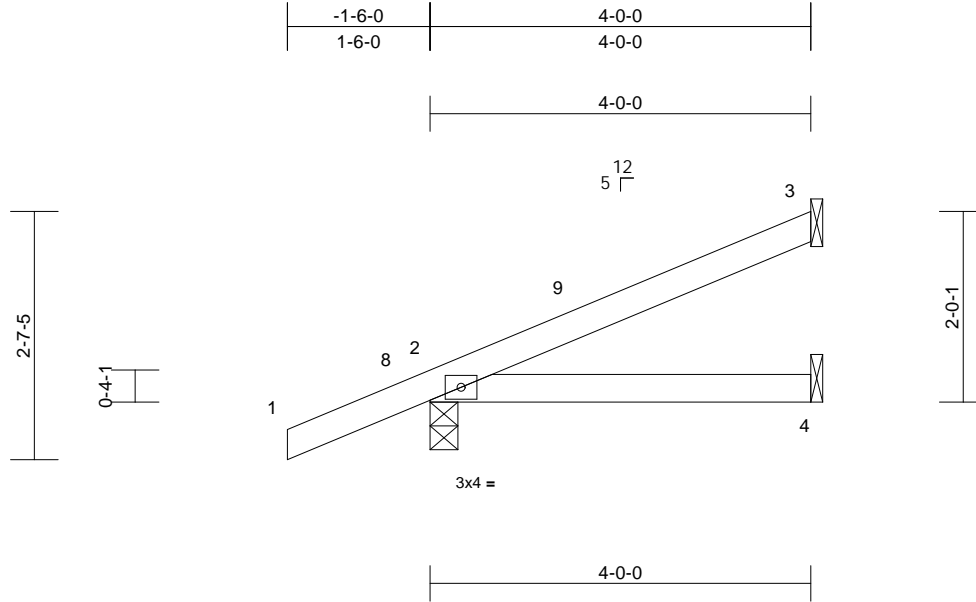

Loading	(psf)	Spacing	2-0-0	CSI	DEFL	in	(loc)	l/defl	L/d	PLATES	GRIP	
TCLL (roof)	20.0	Plate Grip DOL	1.25	TC	0.17	Vert(LL)	0.02	4-7	>999	240	MT20	244/190
TCDL	10.0	Lumber DOL	1.25	BC	0.14	Vert(CT)	-0.02	4-7	>999	180		
BCLL	0.0*	Rep Stress Incr	YES	WB	0.00	Horz(CT)	0.00	3	n/a	n/a		
BCDL	10.0	Code	FBC2023/TPI2014	Matrix-MP							Weight: 15 lb	FT = 20%

LUMBER
TOP CHORD 2x4 SP No.2
BOT CHORD 2x4 SP No.2

BRACING
TOP CHORD Structural wood sheathing directly applied or 4-0-0 oc purlins.
BOT CHORD Rigid ceiling directly applied or 10-0-0 oc bracing.

REACTIONS (size) 2=0-3-8, 3= Mechanical, 4= Mechanical
Max Horiz 2=84 (LC 12)
Max Uplift 2=-112 (LC 8), 3=-53 (LC 12), 4=-26 (LC 9)
Max Grav 2=265 (LC 1), 3=95 (LC 1), 4=69 (LC 3)

FORCES (lb) - Maximum Compression/Maximum Tension
TOP CHORD 1-2=0/35, 2-3=-70/29
BOT CHORD 2-4=-32/43

6) Provide mechanical connection (by others) of truss to bearing plate capable of withstanding 53 lb uplift at joint 3, 112 lb uplift at joint 2 and 26 lb uplift at joint 4.

LOAD CASE(S) Standard

- NOTES**
- 1) Wind: ASCE 7-22; Vult=130mph (3-second gust) Vasd=101mph; TCDL=4.2psf; BCDL=3.0psf; h=18ft; Cat. II; Exp B; Enclosed; MWFRS (envelope) exterior (2) zone and C-C Zone3 -1-6-0 to 1-6-0, Zone1 1-6-0 to 3-11-4 zone; porch left and right exposed; C-C for members and forces & MWFRS for reactions shown; Lumber DOL=1.60 plate grip DOL=1.60
 - 2) Building Designer / Project engineer responsible for verifying applied roof live load shown covers rain loading requirements specific to the use of this truss component.
 - 3) This truss has been designed for a 10.0 psf bottom chord live load nonconcurrent with any other live loads.
 - 4) * This truss has been designed for a live load of 20.0psf on the bottom chord in all areas where a rectangle 3-06-00 tall by 2-00-00 wide will fit between the bottom chord and any other members.
 - 5) Refer to girder(s) for truss to truss connections.

This item has been digitally signed and sealed by ORegan, Philip, PE on the date indicated here. Printed copies of this document are not considered signed and sealed and the signature must be verified on any electronic copies.

Philip J. O'Regan PE No.58126
MiTek Inc. DBA MiTek USA FL Cert 6634
16023 Swingley Ridge Rd. Chesterfield, MO 63017
Date:

March 10,2026

WARNING - Verify design parameters and READ NOTES ON THIS AND INCLUDED MITEK REFERENCE PAGE MII-7473 rev. 1/2/2023 BEFORE USE.

Design valid for use only with MiTek® connectors. This design is based only upon parameters shown, and is for an individual building component, not a truss system. Before use, the building designer must verify the applicability of design parameters and properly incorporate this design into the overall building design. Bracing indicated is to prevent buckling of individual truss web and/or chord members only. Additional temporary and permanent bracing is always required for stability and to prevent collapse with possible personal injury and property damage. For general guidance regarding the fabrication, storage, delivery, erection and bracing of trusses and truss systems, see **ANSI/TPI1 Quality Criteria and DSB-22** available from Truss Plate Institute (www.tpinst.org) and **BCSI Building Component Safety Information** available from the Structural Building Component Association (www.sbcsccomponents.com)

MiTek®

16023 Swingley Ridge Rd.
Chesterfield, MO 63017
314.434.1200 / MiTek-US.com

Job 5240843	Truss HJ01	Truss Type Diagonal Hip Girder	Qty 2	Ply 1	Job Reference (optional)	T40398686
----------------	---------------	-----------------------------------	----------	----------	--------------------------	-----------

Builders FirstSource (Lake City,FL), Lake City, FL - 32055,

Run: 8.83 S Jan 22 2026 Print: 8.830 S Jan 22 2026 MiTek Industries, Inc. Mon Mar 09 14:41:38

Page: 1

ID:1cZGMoQ82uNYvXnszbUoGWznHC-RfC?PsB70Hq3NSgPqnL8w3uITXbGKWRcDoi7J4zJC?f

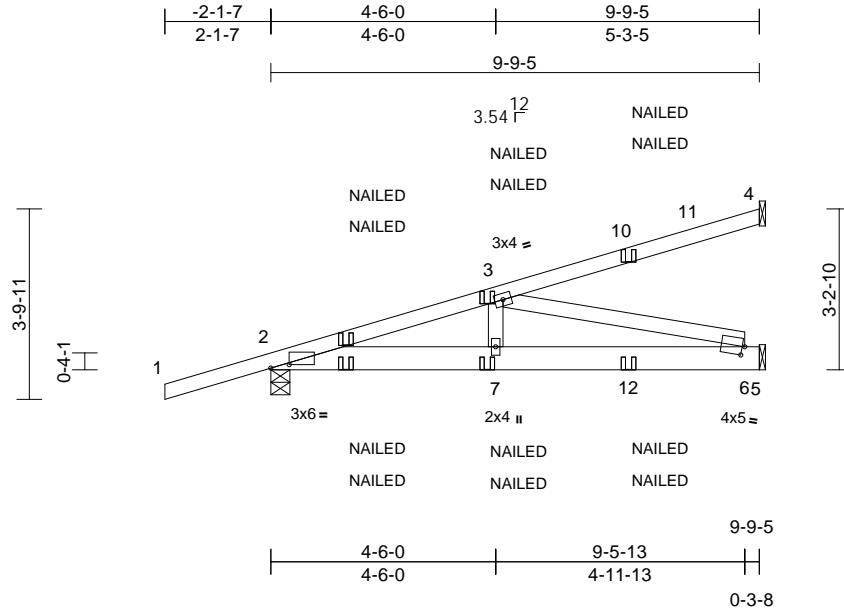

Scale = 1:46.1

Plate Offsets (X, Y): [2:0-4-7,0-0-13], [6:0-0-10,0-2-1]

Loading	(psf)	Spacing	2-0-0	CSI	DEFL	in	(loc)	l/defl	L/d	PLATES	GRIP	
TCLL (roof)	20.0	Plate Grip DOL	1.25	TC	0.62	Vert(LL)	0.04	6-7	>999	240	MT20	244/190
TCDL	10.0	Lumber DOL	1.25	BC	0.36	Vert(CT)	-0.06	6-7	>999	180		
BCLL	0.0*	Rep Stress Incr	NO	WB	0.50	Horz(CT)	0.01	5	n/a	n/a		
BCDL	10.0	Code	FBC2023/TPI2014	Matrix-MS							Weight: 50 lb	FT = 20%

LUMBER
TOP CHORD 2x4 SP No.2
BOT CHORD 2x6 SP No.2
WEBS 2x4 SP No.3

BRACING
TOP CHORD Structural wood sheathing directly applied or 5-7-6 oc purlins.
BOT CHORD Rigid ceiling directly applied or 10-0-0 oc bracing.

REACTIONS (size) 2=0-4-9, 4= Mechanical, 5= Mechanical
Max Horiz 2=138 (LC 25)
Max Uplift 2=-219 (LC 4), 4=-83 (LC 4), 5=-148 (LC 8)
Max Grav 2=518 (LC 1), 4=162 (LC 1), 5=311 (LC 1)

FORCES (lb) - Maximum Compression/Maximum Tension

TOP CHORD 1-2=0/36, 2-3=-964/429, 3-4=-66/37
BOT CHORD 2-7=-468/903, 6-7=-467/903, 5-6=0/0
WEBS 3-7=-56/242, 3-6=-933/483

NOTES

- 1) Wind: ASCE 7-22; Vult=130mph (3-second gust) Vasd=101mph; TCDL=4.2psf; BCDL=3.0psf; h=18ft; Cat. II; Exp B; Enclosed; MWFRS (envelope) exterior (2) zone; Lumber DOL=1.60 plate grip DOL=1.60
- 2) Building Designer / Project engineer responsible for verifying applied roof live load shown covers rain loading requirements specific to the use of this truss component.
- 3) This truss has been designed for a 10.0 psf bottom chord live load nonconcurrent with any other live loads.
- 4) * This truss has been designed for a live load of 20.0psf on the bottom chord in all areas where a rectangle 3-06-00 tall by 2-00-00 wide will fit between the bottom chord and any other members.
- 5) Refer to girder(s) for truss to truss connections.

- 6) Provide mechanical connection (by others) of truss to bearing plate capable of withstanding 83 lb uplift at joint 4, 219 lb uplift at joint 2 and 148 lb uplift at joint 5.
- 7) "NAILED" indicates 3-10d (0.148"x3") or 2-12d (0.148"x3.25") toe-nails per NDS guidelines.
- 8) In the LOAD CASE(S) section, loads applied to the face of the truss are noted as front (F) or back (B).

LOAD CASE(S) Standard

- 1) Dead + Roof Live (balanced): Lumber Increase=1.25, Plate Increase=1.25
Uniform Loads (lb/ft)
Vert: 1-4=-60, 2-5=-20
Concentrated Loads (lb)
Vert: 7=-8 (F=-4, B=-4), 9=63 (F=31, B=31), 10=-77 (F=-39, B=-39), 12=-64 (F=-32, B=-32)

This item has been digitally signed and sealed by ORegan, Philip, PE on the date indicated here. Printed copies of this document are not considered signed and sealed and the signature must be verified on any electronic copies.

Philip J. O'Regan PE No.58126
MiTek Inc. DBA MiTek USA FL Cert 6634
16023 Swingley Ridge Rd. Chesterfield, MO 63017
Date:

March 10,2026

WARNING - Verify design parameters and READ NOTES ON THIS AND INCLUDED MITEK REFERENCE PAGE MII-7473 rev. 1/2/2023 BEFORE USE.

Design valid for use only with MiTek® connectors. This design is based only upon parameters shown, and is for an individual building component, not a truss system. Before use, the building designer must verify the applicability of design parameters and properly incorporate this design into the overall building design. Bracing indicated is to prevent buckling of individual truss web and/or chord members only. Additional temporary and permanent bracing is always required for stability and to prevent collapse with possible personal injury and property damage. For general guidance regarding the fabrication, storage, delivery, erection and bracing of trusses and truss systems, see **ANSI/TPI1 Quality Criteria and DSB-22** available from Truss Plate Institute (www.tpinst.org) and **BCSI Building Component Safety Information** available from the Structural Building Component Association (www.sbcsccomponents.com)

MiTek®

16023 Swingley Ridge Rd.
Chesterfield, MO 63017
314.434.1200 / MiTek-US.com

Job 5240843	Truss HJ03	Truss Type Diagonal Hip Girder	Qty 2	Ply 1	Job Reference (optional) T40398688
----------------	---------------	-----------------------------------	----------	----------	---------------------------------------

Builders FirstSource (Lake City,FL), Lake City, FL - 32055,

Run: 8.83 S Jan 22 2026 Print: 8.830 S Jan 22 2026 MiTek Industries, Inc. Mon Mar 09 14:41:38
ID:Qvp_VWmup?GEe6S5iGyl?xzvCt-RfC?PsB70Hq3NSgPqnL8w3uITXbGKWrCDoi7J4zC?F

Page: 1

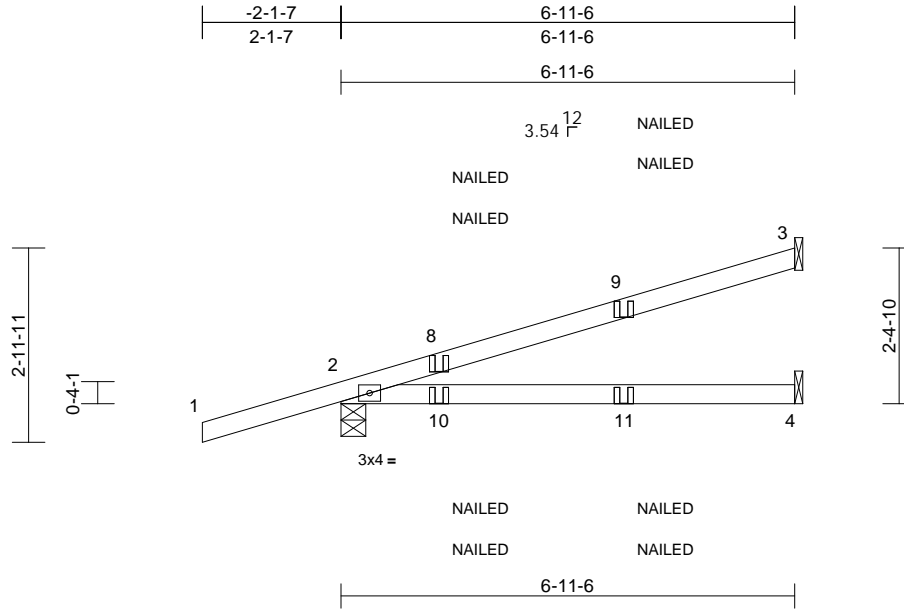

Scale = 1:35.3

Loading	(psf)	Spacing	2-0-0	CSI	DEFL	in	(loc)	l/defl	L/d	PLATES	GRIP	
TCLL (roof)	20.0	Plate Grip DOL	1.25	TC	0.66	Vert(LL)	-0.09	4-7	>900	240	MT20	244/190
TCDL	10.0	Lumber DOL	1.25	BC	0.49	Vert(CT)	-0.18	4-7	>457	180		
BCLL	0.0*	Rep Stress Incr	NO	WB	0.00	Horz(CT)	0.00	3	n/a	n/a		
BCDL	10.0	Code	FBC2023/TPI2014	Matrix-MP							Weight: 25 lb	FT = 20%

LUMBER

TOP CHORD 2x4 SP No.2
BOT CHORD 2x4 SP No.2

BRACING

TOP CHORD Structural wood sheathing directly applied or 6-0-0 oc purlins.
BOT CHORD Rigid ceiling directly applied or 10-0-0 oc bracing.

REACTIONS

(size) 2=0-4-9, 3= Mechanical, 4= Mechanical
Max Horiz 2=110 (LC 25)
Max Uplift 2=-156 (LC 4), 3=-87 (LC 8), 4=-41 (LC 5)
Max Grav 2=376 (LC 1), 3=167 (LC 1), 4=118 (LC 3)

FORCES

(lb) - Maximum Compression/Maximum Tension

TOP CHORD 1-2=0/36, 2-3=-209/137
BOT CHORD 2-4=-128/166

NOTES

- 1) Wind: ASCE 7-22; Vult=130mph (3-second gust) Vasd=101mph; TCDL=4.2psf; BCDL=3.0psf; h=18ft; Cat. II; Exp B; Enclosed; MWFRS (envelope) exterior (2) zone; porch left and right exposed; Lumber DOL=1.60 plate grip DOL=1.60
- 2) Building Designer / Project engineer responsible for verifying applied roof live load shown covers rain loading requirements specific to the use of this truss component.
- 3) This truss has been designed for a 10.0 psf bottom chord live load nonconcurrent with any other live loads.
- 4) * This truss has been designed for a live load of 20.0psf on the bottom chord in all areas where a rectangle 3-06-00 tall by 2-00-00 wide will fit between the bottom chord and any other members.
- 5) Refer to girder(s) for truss to truss connections.
- 6) Provide mechanical connection (by others) of truss to bearing plate capable of withstanding 87 lb uplift at joint 3, 156 lb uplift at joint 2 and 41 lb uplift at joint 4.

- 7) "NAILED" indicates 3-10d (0.148"x3") or 2-12d (0.148"x3.25") toe-nails per NDS guidelines.
 - 8) In the LOAD CASE(S) section, loads applied to the face of the truss are noted as front (F) or back (B).
- LOAD CASE(S)** Standard
- 1) Dead + Roof Live (balanced): Lumber Increase=1.25, Plate Increase=1.25
Uniform Loads (lb/ft)
Vert: 1-3=-60, 4-5=-20
Concentrated Loads (lb)
Vert: 10=63 (F=31, B=31), 11=-8 (F=-4, B=-4)

This item has been digitally signed and sealed by ORegan, Philip, PE on the date indicated here. Printed copies of this document are not considered signed and sealed and the signature must be verified on any electronic copies.

Philip J. O'Regan PE No.58126
MiTek Inc. DBA MiTek USA FL Cert 6634
16023 Swingley Ridge Rd. Chesterfield, MO 63017
Date:

March 10,2026

WARNING - Verify design parameters and READ NOTES ON THIS AND INCLUDED MITEK REFERENCE PAGE MII-7473 rev. 1/2/2023 BEFORE USE.

Design valid for use only with MiTek® connectors. This design is based only upon parameters shown, and is for an individual building component, not a truss system. Before use, the building designer must verify the applicability of design parameters and properly incorporate this design into the overall building design. Bracing indicated is to prevent buckling of individual truss web and/or chord members only. Additional temporary and permanent bracing is always required for stability and to prevent collapse with possible personal injury and property damage. For general guidance regarding the fabrication, storage, delivery, erection and bracing of trusses and truss systems, see **ANSI/TPI1 Quality Criteria and DSB-22** available from Truss Plate Institute (www.tpinst.org) and **BCSI Building Component Safety Information** available from the Structural Building Component Association (www.sbcsccomponents.com)

MiTek®

16023 Swingley Ridge Rd.
Chesterfield, MO 63017
314.434.1200 / MiTek-US.com

Job 5240843	Truss HJ04	Truss Type Diagonal Hip Girder	Qty 1	Ply 1	Job Reference (optional) T40398689
----------------	---------------	-----------------------------------	----------	----------	---------------------------------------

Builders FirstSource (Lake City,FL), Lake City, FL - 32055,

Run: 8.83 S Jan 22 2026 Print: 8.830 S Jan 22 2026 MiTek Industries, Inc. Mon Mar 09 14:41:39
ID:9IHuNoyJ_DaxMitYlcoukVzrvHo-RfC?PsB70Hq3NSgPqnL8w3uITxbGKWrCDoi7J4zJC?f

Page: 1

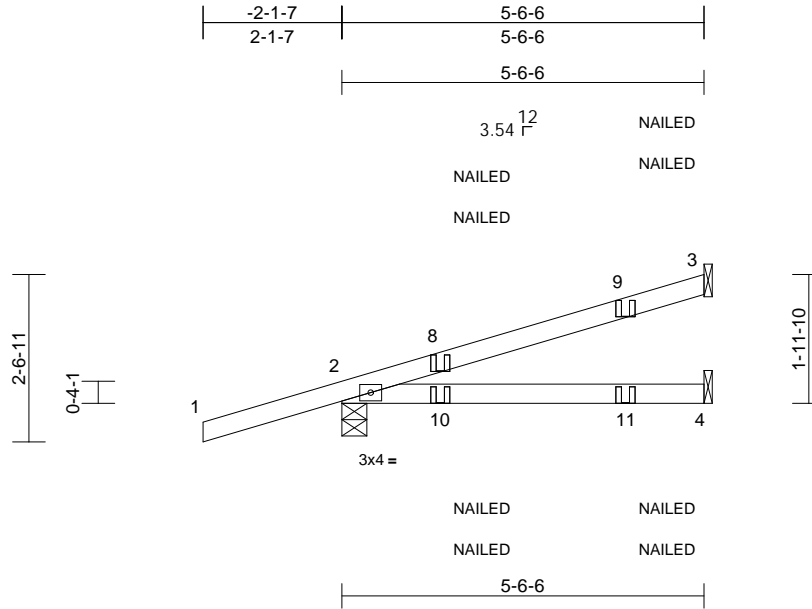

Loading	(psf)	Spacing	2-0-0	CSI	DEFL	in	(loc)	l/defl	L/d	PLATES	GRIP	
TCLL (roof)	20.0	Plate Grip DOL	1.25	TC	0.35	Vert(LL)	-0.04	4-7	>999	240	MT20	244/190
TCDL	10.0	Lumber DOL	1.25	BC	0.26	Vert(CT)	-0.06	4-7	>999	180		
BCLL	0.0*	Rep Stress Incr	NO	WB	0.00	Horz(CT)	0.00	2	n/a	n/a		
BCDL	10.0	Code	FBC2023/TPI2014	Matrix-MP							Weight: 20 lb	FT = 20%

LUMBER
TOP CHORD 2x4 SP No.2
BOT CHORD 2x4 SP No.2

BRACING
TOP CHORD Structural wood sheathing directly applied or 5-6-6 oc purlins.
BOT CHORD Rigid ceiling directly applied or 10-0-0 oc bracing.

REACTIONS (size) 2=0-4-9, 3= Mechanical, 4= Mechanical
Max Horiz 2=94 (LC 25)
Max Uplift 2=-138 (LC 4), 3=-62 (LC 8), 4=-33 (LC 9)
Max Grav 2=327 (LC 1), 3=125 (LC 1), 4=88 (LC 3)

FORCES (lb) - Maximum Compression/Maximum Tension
TOP CHORD 1-2=0/36, 2-3=-202/160
BOT CHORD 2-4=-154/170

- NOTES**
- 1) Wind: ASCE 7-22; Vult=130mph (3-second gust) Vasd=101mph; TCDL=4.2psf; BCDL=3.0psf; h=18ft; Cat. II; Exp B; Enclosed; MWFRS (envelope) exterior (2) zone; porch left and right exposed; Lumber DOL=1.60 plate grip DOL=1.60
 - 2) Building Designer / Project engineer responsible for verifying applied roof live load shown covers rain loading requirements specific to the use of this truss component.
 - 3) This truss has been designed for a 10.0 psf bottom chord live load nonconcurrent with any other live loads.
 - 4) * This truss has been designed for a live load of 20.0psf on the bottom chord in all areas where a rectangle 3-06-00 tall by 2-00-00 wide will fit between the bottom chord and any other members.
 - 5) Refer to girder(s) for truss to truss connections.
 - 6) Provide mechanical connection (by others) of truss to bearing plate capable of withstanding 62 lb uplift at joint 3, 138 lb uplift at joint 2 and 33 lb uplift at joint 4.

- 7) "NAILED" indicates 3-10d (0.148"x3") or 2-12d (0.148"x3.25") toe-nails per NDS guidelines.
 - 8) In the LOAD CASE(S) section, loads applied to the face of the truss are noted as front (F) or back (B).
- LOAD CASE(S)** Standard
- 1) Dead + Roof Live (balanced): Lumber Increase=1.25, Plate Increase=1.25
Uniform Loads (lb/ft)
Vert: 1-3=-60, 4-5=-20
Concentrated Loads (lb)
Vert: 10=63 (F=31, B=31), 11=-9 (F=-5, B=-5)

This item has been digitally signed and sealed by O'Regan, Philip, PE on the date indicated here. Printed copies of this document are not considered signed and sealed and the signature must be verified on any electronic copies.

Philip J. O'Regan PE No.58126
MiTek Inc. DBA MiTek USA FL Cert 6634
16023 Swingley Ridge Rd. Chesterfield, MO 63017
Date:

March 10, 2026

WARNING - Verify design parameters and READ NOTES ON THIS AND INCLUDED MITEK REFERENCE PAGE MII-7473 rev. 1/2/2023 BEFORE USE.

Design valid for use only with MiTek® connectors. This design is based only upon parameters shown, and is for an individual building component, not a truss system. Before use, the building designer must verify the applicability of design parameters and properly incorporate this design into the overall building design. Bracing indicated is to prevent buckling of individual truss web and/or chord members only. Additional temporary and permanent bracing is always required for stability and to prevent collapse with possible personal injury and property damage. For general guidance regarding the fabrication, storage, delivery, erection and bracing of trusses and truss systems, see **ANSI/TPI1 Quality Criteria and DSB-22** available from Truss Plate Institute (www.tpinst.org) and **BCSI Building Component Safety Information** available from the Structural Building Component Association (www.sbcsccomponents.com)

MiTek®

16023 Swingley Ridge Rd.
Chesterfield, MO 63017
314.434.1200 / MiTek-US.com

Job 5240843	Truss T03	Truss Type Common	Qty 7	Ply 1	Job Reference (optional)	T40398690
----------------	--------------	----------------------	----------	----------	--------------------------	-----------

Builders FirstSource (Lake City,FL), Lake City, FL - 32055,

Run: 8.83 S Jan 22 2026 Print: 8.830 S Jan 22 2026 MiTek Industries, Inc. Mon Mar 09 14:41:39
ID:DcWQjIWDuFPpETm8WXWqlzrvAd-RfC?PsB70Hq3NSgPqnL8w3ulTXbGKWrcDoi7J4zJC?f

Page: 1

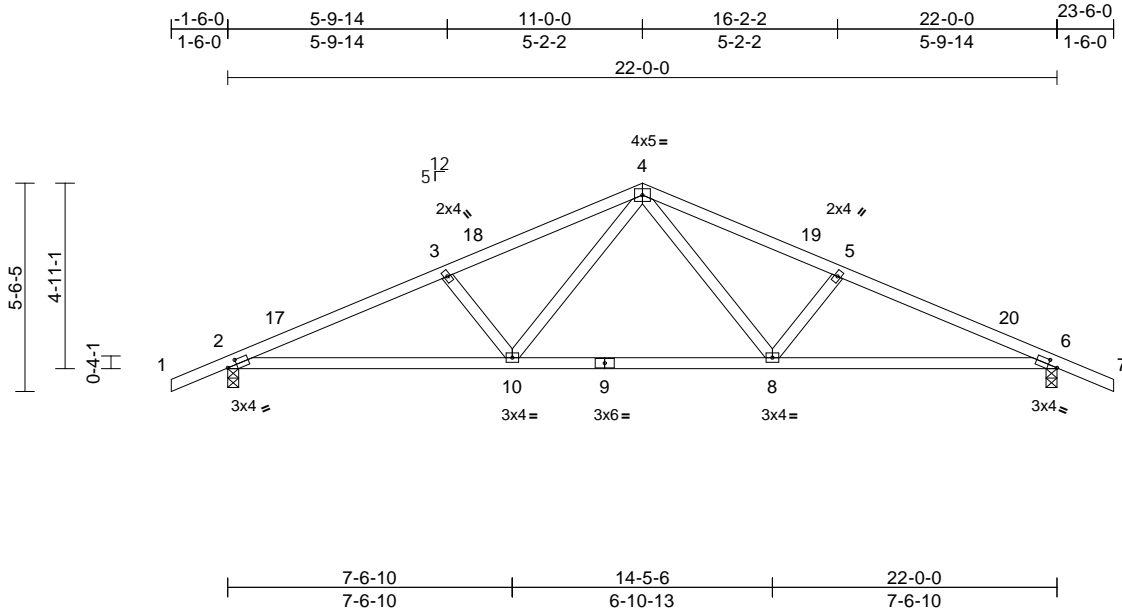

Scale = 1:61.1

Plate Offsets (X, Y): [2:0-3-0-0-1-8], [6:0-3-0-0-1-8]

Loading	(psf)	Spacing	2-0-0	CSI	DEFL	in	(loc)	l/defl	L/d	PLATES	GRIP	
TCLL (roof)	20.0	Plate Grip DOL	1.25	TC	0.41	Vert(LL)	-0.08	8-16	>999	240	MT20	244/190
TCDL	10.0	Lumber DOL	1.25	BC	0.71	Vert(CT)	-0.20	8-16	>999	180		
BCLL	0.0*	Rep Stress Incr	NO	WB	0.68	Horz(CT)	0.05	6	n/a	n/a		
BCDL	10.0	Code	FBC2023/TPI2014	Matrix-MS							Weight: 98 lb	FT = 20%

LUMBER
TOP CHORD 2x4 SP No.2
BOT CHORD 2x4 SP No.2
WEBS 2x4 SP No.3

BRACING
TOP CHORD Structural wood sheathing directly applied or 3-9-15 oc purlins.
BOT CHORD Rigid ceiling directly applied or 8-8-14 oc bracing.

REACTIONS (size) 2=0-3-8, 6=0-3-8
Max Horiz 2=-87 (LC 13)
Max Uplift 2=-277 (LC 12), 6=-287 (LC 13)
Max Grav 2=1057 (LC 1), 6=1090 (LC 1)

FORCES (lb) - Maximum Compression/Maximum Tension
TOP CHORD 1-2=0/35, 2-3=-1956/477, 3-4=-1766/443, 4-5=-1848/468, 5-6=-2038/502, 6-7=0/35
BOT CHORD 2-10=-451/1773, 8-10=-235/1250, 6-8=-387/1849
WEBS 3-10=-351/204, 4-10=-156/543, 4-8=-215/736, 5-8=-350/204

- NOTES**
- Unbalanced roof live loads have been considered for this design.
 - Wind: ASCE 7-22; Vult=130mph (3-second gust) Vasd=101mph; TCDL=4.2psf; BCDL=3.0psf; h=18ft; Cat. II; Exp B; Enclosed; MWFRS (envelope) exterior (2) zone and C-C Zone3 -1-6-0 to 1-6-0, Zone1 1-6-0 to 11-0-0, Zone2 11-0-0 to 15-2-15, Zone1 15-2-15 to 23-6-0 zone;C-C for members and forces & MWFRS for reactions shown; Lumber DOL=1.60 plate grip DOL=1.60
 - Building Designer / Project engineer responsible for verifying applied roof live load shown covers rain loading requirements specific to the use of this truss component.
 - This truss has been designed for a 10.0 psf bottom chord live load nonconcurrent with any other live loads.

- * This truss has been designed for a live load of 20.0psf on the bottom chord in all areas where a rectangle 3-06-00 tall by 2-00-00 wide will fit between the bottom chord and any other members.
 - Provide mechanical connection (by others) of truss to bearing plate capable of withstanding 277 lb uplift at joint 2 and 287 lb uplift at joint 6.
- LOAD CASE(S)** Standard
- Dead + Roof Live (balanced): Lumber Increase=1.25, Plate Increase=1.25
Uniform Loads (lb/ft)
Vert: 1-4=-60, 4-7=-60, 11-14=-20, 4-8=-60

This item has been digitally signed and sealed by ORegan, Philip, PE on the date indicated here. Printed copies of this document are not considered signed and sealed and the signature must be verified on any electronic copies.

Philip J. O'Regan PE No.58126
MiTek Inc. DBA MiTek USA FL Cert 6634
16023 Swingley Ridge Rd. Chesterfield, MO 63017
Date:

March 10,2026

<p>WARNING - Verify design parameters and READ NOTES ON THIS AND INCLUDED MITEK REFERENCE PAGE MII-7473 rev. 1/2/2023 BEFORE USE.</p> <p>Design valid for use only with MiTek® connectors. This design is based only upon parameters shown, and is for an individual building component, not a truss system. Before use, the building designer must verify the applicability of design parameters and properly incorporate this design into the overall building design. Bracing indicated is to prevent buckling of individual truss web and/or chord members only. Additional temporary and permanent bracing is always required for stability and to prevent collapse with possible personal injury and property damage. For general guidance regarding the fabrication, storage, delivery, erection and bracing of trusses and truss systems, see ANSI/TPI1 Quality Criteria and DSB-22 available from Truss Plate Institute (www.tpinst.org) and BCSI Building Component Safety Information available from the Structural Building Component Association (www.sbcsccomponents.com)</p>	 <p>16023 Swingley Ridge Rd. Chesterfield, MO 63017 314.434.1200 / MiTek-US.com</p>
--	--

Job 5240843	Truss T03G	Truss Type Common Supported Gable	Qty 1	Ply 1	Job Reference (optional)	T40398691
----------------	---------------	--------------------------------------	----------	----------	--------------------------	-----------

Builders FirstSource (Lake City,FL), Lake City, FL - 32055,

Run: 8.83 S Jan 22 2026 Print: 8.830 S Jan 22 2026 MiTek Industries, Inc. Mon Mar 09 14:41:39
ID:QggNRTFFiIkZn49O0cfdsczeHD-RfC?PsB70Hq3NSgPqnL8w3uITxGKWrCDoi7J4zJC7f

Page: 1

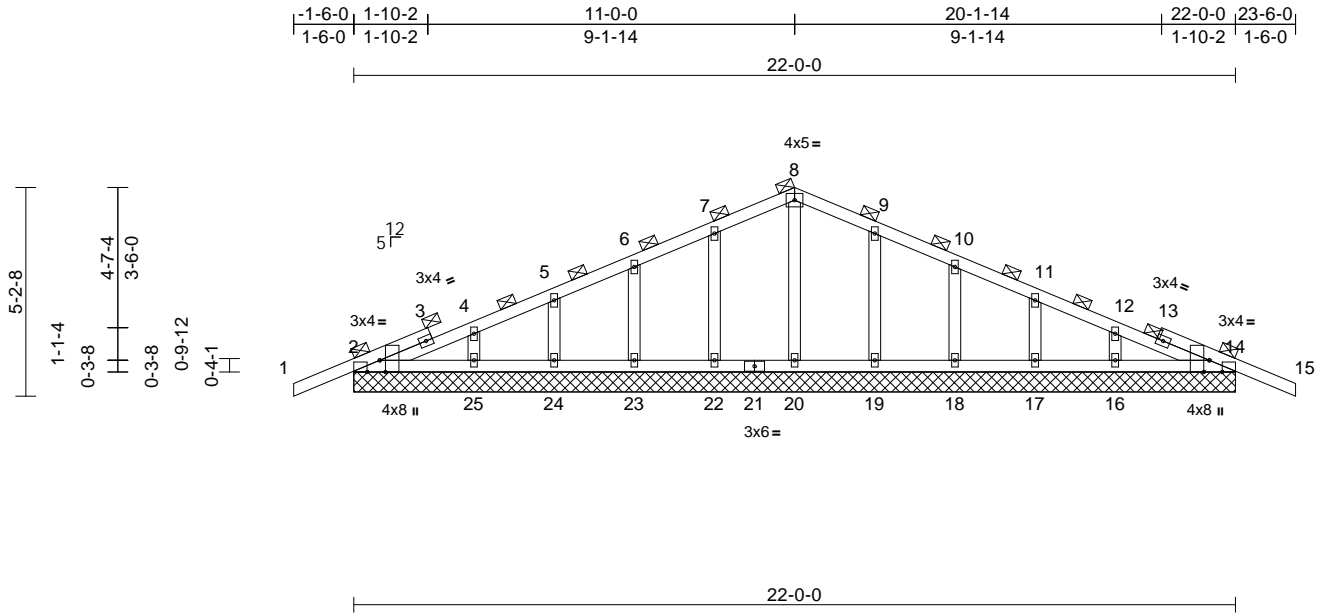

Scale = 1:57.5

Plate Offsets (X, Y): [2:0-3-8,Edge], [2:0-3-13,Edge], [14:0-3-8,Edge], [14:0-3-13,Edge]

Loading	(psf)	Spacing	2-0-0	CSI	DEFL	in	(loc)	l/defl	L/d	PLATES	GRIP	
TCLL (roof)	20.0	Plate Grip DOL	1.25	TC	0.15	Vert(LL)	n/a	-	n/a	999	MT20	244/190
TCDL	10.0	Lumber DOL	1.25	BC	0.05	Vert(CT)	n/a	-	n/a	999		
BCLL	0.0*	Rep Stress Incr	YES	WB	0.04	Horz(CT)	0.00	29	n/a	n/a		
BCDL	10.0	Code	FBC2023/TPI2014	Matrix-MS							Weight: 107 lb	FT = 20%

LUMBER

- TOP CHORD 2x4 SP No.2
- BOT CHORD 2x4 SP No.2
- OTHERS 2x4 SP No.3

BRACING

- TOP CHORD 2-0-0 oc purlins (6-0-0 max.).
- BOT CHORD Rigid ceiling directly applied or 10-0-0 oc bracing.

REACTIONS

- (size) 2=22-0-0, 14=22-0-0, 16=22-0-0, 17=22-0-0, 18=22-0-0, 19=22-0-0, 20=22-0-0, 22=22-0-0, 23=22-0-0, 24=22-0-0, 25=22-0-0
- Max Horiz 2=-82 (LC 13)
- Max Uplift 2=-75 (LC 8), 14=-78 (LC 9), 16=-66 (LC 13), 17=-61 (LC 13), 18=-62 (LC 13), 19=-65 (LC 13), 22=-65 (LC 12), 23=-62 (LC 12), 24=-61 (LC 12), 25=-62 (LC 12)
- Max Grav 2=220 (LC 1), 14=220 (LC 1), 16=201 (LC 1), 17=149 (LC 26), 18=161 (LC 1), 19=168 (LC 26), 20=145 (LC 22), 22=168 (LC 25), 23=161 (LC 1), 24=149 (LC 25), 25=201 (LC 1)

FORCES

- (lb) - Maximum Compression/Maximum Tension
- TOP CHORD 1-2=0/35, 2-4=-68/53, 4-5=-53/58, 5-6=-32/76, 6-7=-39/98, 7-8=-55/136, 8-9=-55/136, 9-10=-39/98, 10-11=-28/60, 11-12=-30/25, 12-14=-34/27, 14-15=0/35
- BOT CHORD 2-25=-26/76, 24-25=-26/76, 23-24=-26/76, 22-23=-26/76, 20-22=-26/76, 19-20=-26/76, 18-19=-26/76, 17-18=-26/76, 16-17=-26/76, 14-16=-26/76
- WEBS 8-20=-105/0, 7-22=-129/83, 6-23=-120/82, 5-24=-116/84, 4-25=-139/80, 9-19=-129/83, 10-18=-120/82, 11-17=-116/84, 12-16=-139/80

NOTES

- Unbalanced roof live loads have been considered for this design.
- Wind: ASCE 7-22; Vult=130mph (3-second gust) Vasd=101mph; TCdL=4.2psf; BCdL=3.0psf; h=18ft; Cat. II; Exp B; Enclosed; MWFRS (envelope) exterior (2) zone and C-C Zone3 zone; C-C for members and forces & MWFRS for reactions shown; Lumber DOL=1.60 plate grip DOL=1.60
- Truss designed for wind loads in the plane of the truss only. For studs exposed to wind (normal to the face), see Standard Industry Gable End Details as applicable, or consult qualified building designer as per ANSI/TPI 1.
- Building Designer / Project engineer responsible for verifying applied roof live load shown covers rain loading requirements specific to the use of this truss component.
- All plates are 2x4 (||) MT20 unless otherwise indicated.
- Gable requires continuous bottom chord bearing.
- Gable studs spaced at 2-0-0 oc.
- This truss has been designed for a 10.0 psf bottom chord live load nonconcurrent with any other live loads.
- * This truss has been designed for a live load of 20.0psf on the bottom chord in all areas where a rectangle 3-06-00 tall by 2-00-00 wide will fit between the bottom chord and any other members.
- Provide mechanical connection (by others) of truss to bearing plate capable of withstanding 75 lb uplift at joint 2, 78 lb uplift at joint 14, 65 lb uplift at joint 22, 62 lb uplift at joint 23, 61 lb uplift at joint 24, 62 lb uplift at joint 25, 65 lb uplift at joint 19, 62 lb uplift at joint 18, 61 lb uplift at joint 17, 66 lb uplift at joint 16, 75 lb uplift at joint 2 and 78 lb uplift at joint 14.
- Graphical purlin representation does not depict the size or the orientation of the purlin along the top and/or bottom chord.

LOAD CASE(S) Standard

This item has been digitally signed and sealed by O'Regan, Philip, PE on the date indicated here. Printed copies of this document are not considered signed and sealed and the signature must be verified on any electronic copies.

Philip J. O'Regan PE No.58126
MiTek Inc. DBA MiTek USA FL Cert 6634
16023 Swingley Ridge Rd. Chesterfield, MO 63017
Date:

March 10, 2026

WARNING - Verify design parameters and READ NOTES ON THIS AND INCLUDED MITEK REFERENCE PAGE MII-7473 rev. 1/2/2023 BEFORE USE.

Design valid for use only with MiTek® connectors. This design is based only upon parameters shown, and is for an individual building component, not a truss system. Before use, the building designer must verify the applicability of the design parameters and properly incorporate this design into the overall building design. Bracing indicated is to prevent buckling of individual truss web and/or chord members only. Additional temporary and permanent bracing is always required for stability and to prevent collapse with possible personal injury and property damage. For general guidance regarding the fabrication, storage, delivery, erection and bracing of trusses and truss systems, see **ANSI/TPI1 Quality Criteria and DSB-22** available from Truss Plate Institute (www.tpinst.org) and **BCSI Building Component Safety Information** available from the Structural Building Component Association (www.sbcsccomponents.com)

MiTek®

16023 Swingley Ridge Rd.
Chesterfield, MO 63017
314.434.1200 / MiTek-US.com

Job 5240843	Truss T04	Truss Type Common	Qty 4	Ply 1	Job Reference (optional)	T40398692
----------------	--------------	----------------------	----------	----------	--------------------------	-----------

Builders FirstSource (Lake City,FL), Lake City, FL - 32055,

Run: 8.83 S Jan 22 2026 Print: 8.830 S Jan 22 2026 MiTek Industries, Inc. Mon Mar 09 14:41:40
ID:hL7f3jxAf?prdceVhMfklhznvA4-RfC?PsB70Hq3NSgPqnL8w3ulTXbGKWRcDoi7J4zJC?f

Page: 1

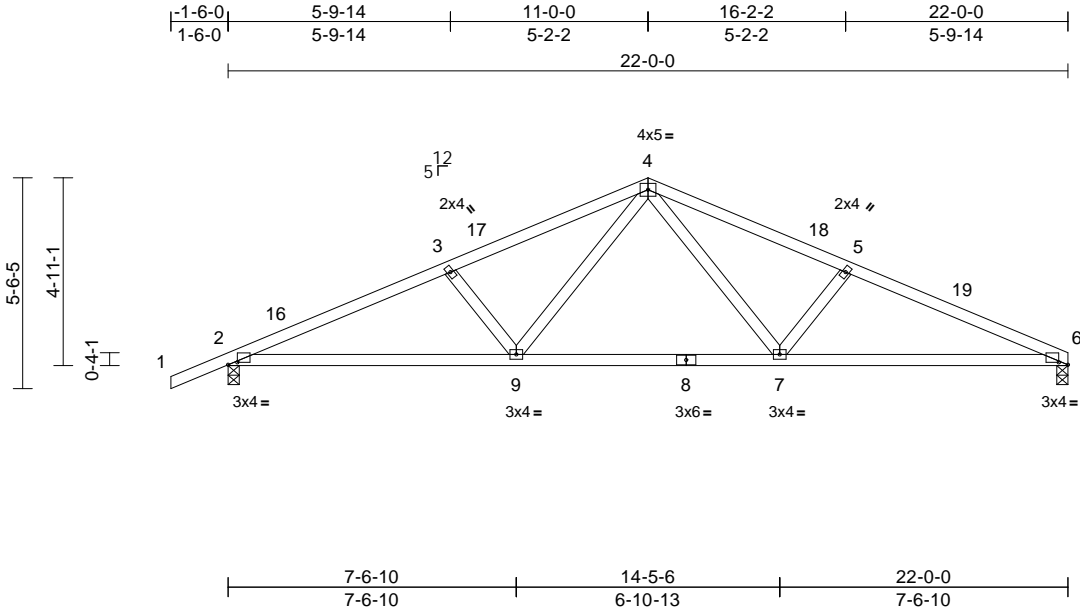

Scale = 1:60.4

Plate Offsets (X, Y): [2:0-2-14,0-0-12], [6:0-2-14,0-0-12]

Loading	(psf)	Spacing	2-0-0	CSI	DEFL	in	(loc)	l/defl	L/d	PLATES	GRIP	
TCLL (roof)	20.0	Plate Grip DOL	1.25	TC	0.43	Vert(LL)	-0.08	7-12	>999	240	MT20	244/190
TCDL	10.0	Lumber DOL	1.25	BC	0.68	Vert(CT)	-0.19	7-12	>999	180		
BCLL	0.0*	Rep Stress Incr	NO	WB	0.21	Horz(CT)	0.05	6	n/a	n/a		
BCDL	10.0	Code	FBC2023/TPI2014	Matrix-MS							Weight: 96 lb	FT = 20%

LUMBER

TOP CHORD 2x4 SP No.2
BOT CHORD 2x4 SP No.2
WEBS 2x4 SP No.3

BRACING

TOP CHORD Structural wood sheathing directly applied or 4-0-4 oc purlins.
BOT CHORD Rigid ceiling directly applied or 9-3-2 oc bracing.

REACTIONS

(size) 2=0-3-8, 6=0-3-8
Max Horiz 2=97 (LC 12)
Max Uplift 2=-251 (LC 12), 6=-212 (LC 13)
Max Grav 2=973 (LC 1), 6=877 (LC 1)

FORCES

(lb) - Maximum Compression/Maximum Tension
TOP CHORD 1-2=0/35, 2-3=-1741/411, 3-4=-1550/377, 4-5=-1564/386, 5-6=-1757/421
BOT CHORD 2-9=-401/1575, 7-9=-184/1050, 6-7=-335/1593
WEBS 4-9=-157/545, 3-9=-353/205, 4-7=-166/563, 5-7=-363/210

NOTES

- Unbalanced roof live loads have been considered for this design.
- Wind: ASCE 7-22; Vult=130mph (3-second gust) Vasd=101mph; TCDL=4.2psf; BCDL=3.0psf; h=18ft; Cat. II; Exp B; Enclosed; MWFRS (envelope) exterior (2) zone and C-C Zone3 -1-6-0 to 1-6-0, Zone1 1-6-0 to 11-0-0, Zone2 11-0-0 to 15-2-15, Zone1 15-2-15 to 22-0-0 zone;C-C for members and forces & MWFRS for reactions shown; Lumber DOL=1.60 plate grip DOL=1.60
- Building Designer / Project engineer responsible for verifying applied roof live load shown covers rain loading requirements specific to the use of this truss component.
- This truss has been designed for a 10.0 psf bottom chord live load nonconcurrent with any other live loads.

- * This truss has been designed for a live load of 20.0psf on the bottom chord in all areas where a rectangle 3-06-00 tall by 2-00-00 wide will fit between the bottom chord and any other members.
- Provide mechanical connection (by others) of truss to bearing plate capable of withstanding 212 lb uplift at joint 6 and 251 lb uplift at joint 2.

LOAD CASE(S) Standard

- Dead + Roof Live (balanced): Lumber Increase=1.25, Plate Increase=1.25
Uniform Loads (lb/ft)
Vert: 1-4=-60, 4-6=-60, 10-13=-20

This item has been digitally signed and sealed by ORegan, Philip, PE on the date indicated here. Printed copies of this document are not considered signed and sealed and the signature must be verified on any electronic copies.

Philip J. O'Regan PE No.58126
MiTek Inc. DBA MiTek USA FL Cert 6634
16023 Swingley Ridge Rd. Chesterfield, MO 63017
Date:

March 10,2026

WARNING - Verify design parameters and READ NOTES ON THIS AND INCLUDED MITEK REFERENCE PAGE MII-7473 rev. 1/2/2023 BEFORE USE.

Design valid for use only with MiTek® connectors. This design is based only upon parameters shown, and is for an individual building component, not a truss system. Before use, the building designer must verify the applicability of design parameters and properly incorporate this design into the overall building design. Bracing indicated is to prevent buckling of individual truss web and/or chord members only. Additional temporary and permanent bracing is always required for stability and to prevent collapse with possible personal injury and property damage. For general guidance regarding the fabrication, storage, delivery, erection and bracing of trusses and truss systems, see **ANSI/TPI1 Quality Criteria and DSB-22** available from Truss Plate Institute (www.tpinst.org) and **BCSI Building Component Safety Information** available from the Structural Building Component Association (www.sbcsccomponents.com)

MiTek®

16023 Swingley Ridge Rd.
Chesterfield, MO 63017
314.434.1200 / MiTek-US.com

Job 5240843	Truss T05	Truss Type Half Hip Girder	Qty 1	Ply 2	Job Reference (optional) T40398693
----------------	--------------	-------------------------------	----------	----------	---------------------------------------

Builders FirstSource (Lake City,FL), Lake City, FL - 32055,

Run: 8.83 S Jan 22 2026 Print: 8.830 S Jan 22 2026 MiTek Industries, Inc. Mon Mar 09 14:41:40
ID:1hgeHXCXY0kzWoXFZWPM2_znuPz-RfC?PsB70Hq3NSgPqnL8w3uITXbGKWRcDoi7J4zJC?f

Page: 1

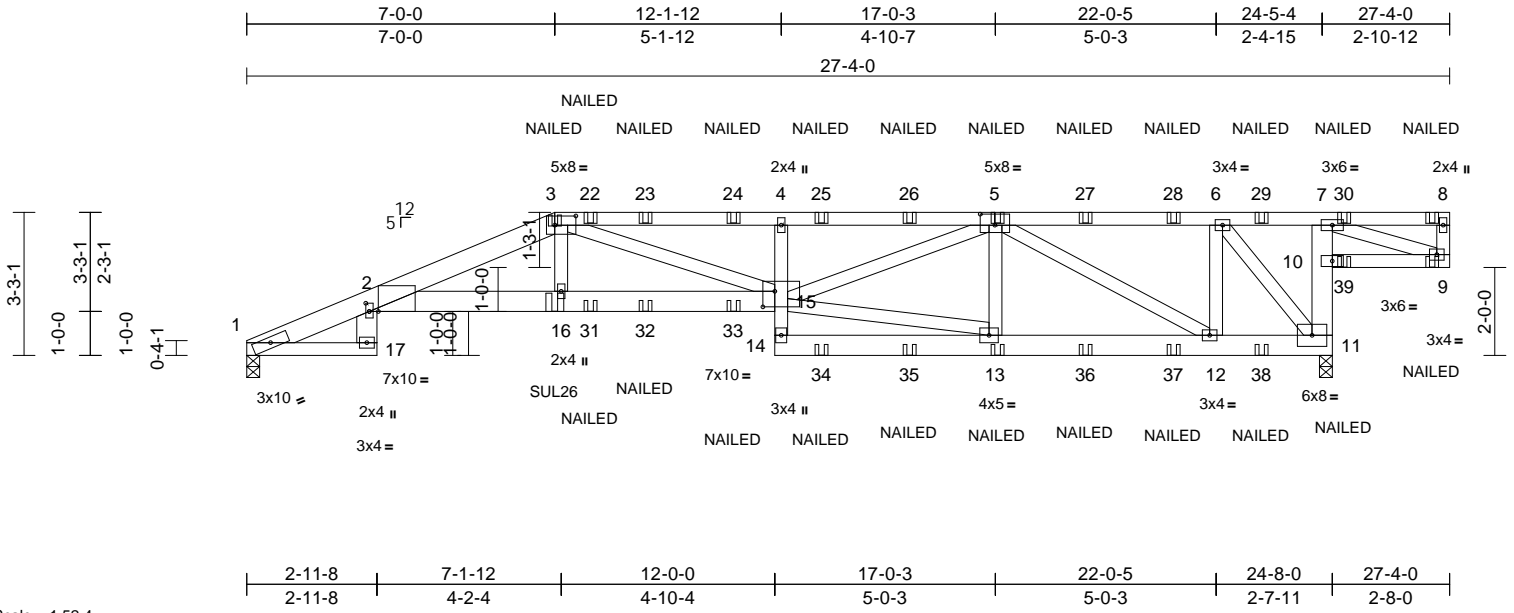

Scale = 1:52.4
Plate Offsets (X, Y): [2:0-2-8,Edge], [2:0-2-4,0-0-15], [3:0-5-12,0-2-8], [5:0-4-0,0-3-0], [15:0-3-4,0-4-4]

Loading	(psf)	Spacing	2-0-0	CSI	DEFL	in	(loc)	l/defl	L/d	PLATES	GRIP	
TCLL (roof)	20.0	Plate Grip DOL	1.25	TC	0.94	Vert(LL)	0.28	2-16	>999	2/4	MT20	244/190
TCDL	10.0	Lumber DOL	1.25	BC	0.77	Vert(CT)	-0.53	15-16	>550	180		
BCLL	0.0*	Rep Stress Incr	NO	WB	0.58	Horz(CT)	0.26	11	n/a	n/a		
BCDL	10.0	Code	FBC2023/TPI2014	Matrix-MS								

Weight: 335 lb FT = 20%

LUMBER
TOP CHORD 2x4 SP No.2 *Except* 1-3:2x6 SP 2400F 2.0E or 2x6 SP M 26
BOT CHORD 2x4 SP No.2 *Except* 17-2,14-11,11-7:2x6 SP No.2, 2-15:2x6 SP 2400F 2.0E or 2x6 SP M 26
WEBS 2x4 SP No.3

BRACING
TOP CHORD Structural wood sheathing directly applied or 4-2-6 oc purlins.
BOT CHORD Rigid ceiling directly applied or 10-0-0 oc bracing, Except: 6-0-0 oc bracing: 9-10.

REACTIONS (size) 1=0-3-8, 11=0-3-8
Max Horiz 1=114 (LC 27)
Max Uplift 1=625 (LC 8), 11=958 (LC 5)
Max Grav 1=1885 (LC 1), 11=2809 (LC 1)

FORCES (lb) - Maximum Compression/Maximum Tension
TOP CHORD 1-2=-1135/309, 2-3=-6645/2285, 3-4=-6818/2330, 4-6=-6673/2285, 6-7=-111/303, 7-8=0/0
BOT CHORD 1-17=-98/259, 2-17=-194/569, 2-16=-2193/6236, 15-16=-2232/6358, 14-15=-16/220, 4-15=-562/279, 13-14=-297/892, 12-13=-1272/3809, 11-12=-475/1418, 10-11=-753/283, 7-10=-613/234, 9-10=-834/296
WEBS 8-9=-165/68, 3-16=-513/1580, 3-15=-183/635, 5-13=-387/244, 13-15=-997/2980, 5-15=-1109/3069, 6-12=-461/1633, 6-11=-2680/896, 5-12=-2755/920, 7-9=-314/884

- 2-ply truss to be connected together with 10d (0.131"x3") nails as follows:
Top chords connected as follows: 2x6 - 2 rows staggered at 0-9-0 oc, 2x4 - 1 row at 0-9-0 oc.
Bottom chords connected as follows: 2x4 - 1 row at 0-9-0 oc, 2x6 - 2 rows staggered at 0-9-0 oc.
Web connected as follows: 2x4 - 1 row at 0-9-0 oc.
- All loads are considered equally applied to all plies, except if noted as front (F) or back (B) face in the LOAD CASE(S) section. Ply to ply connections have been provided to distribute only loads noted as (F) or (B), unless otherwise indicated.
- Unbalanced roof live loads have been considered for this design.
- Wind: ASCE 7-22; Vult=130mph (3-second gust) Vasd=101mph; TC DL=4.2psf; BC DL=3.0psf; h=18ft; Cat. II; Exp B; Enclosed; MWFRS (envelope) exterior (2) zone; cantilever right exposed ; Lumber DOL=1.60 plate grip DOL=1.60
- Building Designer / Project engineer responsible for verifying applied roof live load shown covers rain loading requirements specific to the use of this truss component.
- Provide adequate drainage to prevent water ponding.
- This truss has been designed for a 10.0 psf bottom chord live load nonconcurrent with any other live loads.
- * This truss has been designed for a live load of 20.0psf on the bottom chord in all areas where a rectangle 3-06-00 tall by 2-00-00 wide will fit between the bottom chord and any other members.
- Provide mechanical connection (by others) of truss to bearing plate capable of withstanding 625 lb uplift at joint 1 and 958 lb uplift at joint 11.
- Use Simpson Strong-Tie SUL26 (6-10d Girder, 6-10dx1 1/2 Truss) or equivalent at 7-0-0 from the left end to connect truss(es) to front face of bottom chord, skewed 45.0 deg.to the left, sloping 0.0 deg. down.
- Fill all nail holes where hanger is in contact with lumber.
- "NAILED" indicates 3-10d (0.148"x3") or 2-12d (0.148"x3.25") toe-nails per NDS guidelines.

13) Hanger(s) or other connection device(s) shall be provided sufficient to support concentrated load(s) 110 lb down and 52 lb up at 27-2-4 on top chord, and 110 lb down and 37 lb up at 27-2-4 on bottom chord. The design/selection of such connection device(s) is the responsibility of others.

LOAD CASE(S) Standard
1) Dead + Roof Live (balanced): Lumber Increase=1.25, Plate Increase=1.25
Uniform Loads (lb/ft)
Vert: 2-20=-60, 2-3=-60, 3-8=-60, 1-17=-20, 2-15=-20, 11-14=-20, 9-10=-20
Concentrated Loads (lb)
Vert: 8=-110 (F), 16=-424 (F), 13=-68 (F), 5=-120 (F), 9=-110 (F), 22=-104 (F), 23=-104 (F), 24=-104 (F), 25=-120 (F), 26=-120 (F), 27=-120 (F), 28=-120 (F), 29=-120 (F), 30=-87 (F), 31=-85 (F), 32=-85 (F), 33=-85 (F), 34=-68 (F), 35=-68 (F), 36=-68 (F), 37=-68 (F), 38=-68 (F), 39=-102 (F)

This item has been digitally signed and sealed by O'Regan, Philip, PE on the date indicated here. Printed copies of this document are not considered signed and sealed and the signature must be verified on any electronic copies.

Philip J. O'Regan PE No.58126
MiTek Inc. DBA MiTek USA FL Cert 6634
16023 Swingley Ridge Rd. Chesterfield, MO 63017
Date:

March 10, 2026

Job 5240843	Truss T06	Truss Type Half Hip	Qty 1	Ply 1	Job Reference (optional)	T40398694
----------------	--------------	------------------------	----------	----------	--------------------------	-----------

Builders FirstSource (Lake City,FL), Lake City, FL - 32055,

Run: 8.83 S Jan 22 2026 Print: 8.830 S Jan 22 2026 MiTek Industries, Inc. Mon Mar 09 14:41:41
ID:N1JzwN1hODWkNtccNe90cXznuRU-RfC?PsB70Hq3NSgPqnL8w3uITxBGKWrCDoi7J4zJC?f

Page: 1

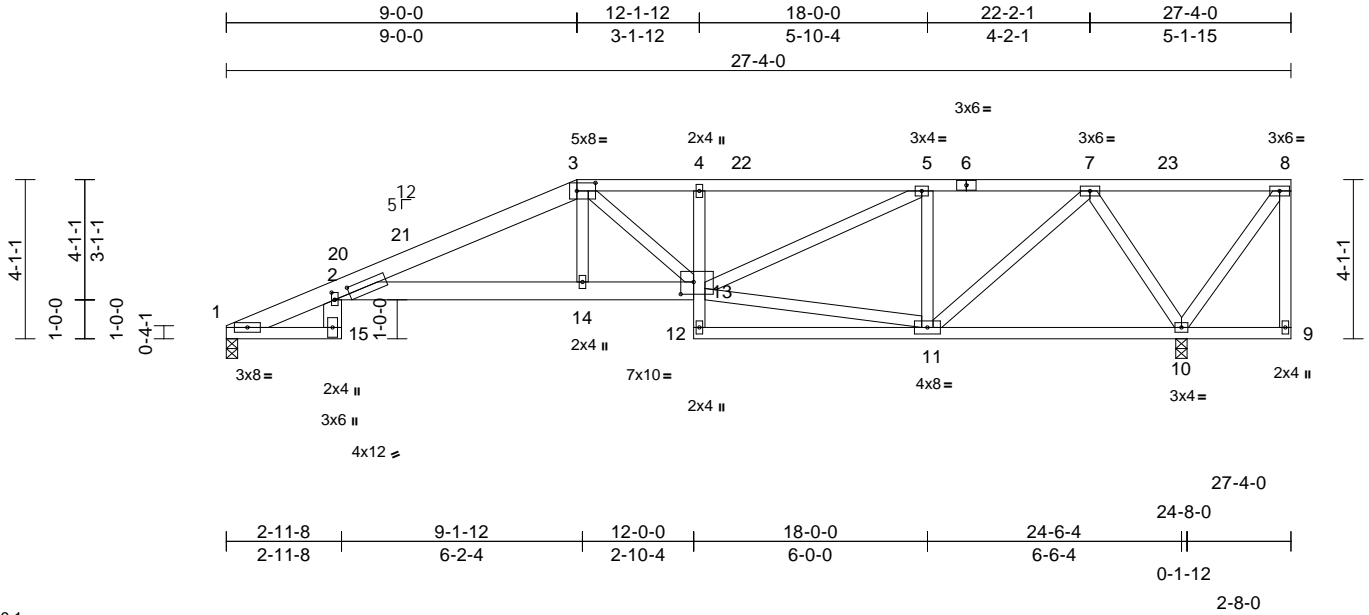

Scale = 1:59.1

Plate Offsets (X, Y): [2:0-4-14,0-2-0], [2:0-2-4,0-0-15], [3:0-5-12,0-2-8], [13:0-4-0,0-3-12]

Loading	(psf)	Spacing	2-0-0	CSI	DEFL	in	(loc)	l/defl	L/d	PLATES	GRIP	
TCLL (roof)	20.0	Plate Grip DOL	1.25	TC	0.79	Vert(LL)	0.30	2-14	>981	240	MT20	244/190
TCDL	10.0	Lumber DOL	1.25	BC	0.72	Vert(CT)	-0.58	2-14	>506	180		
BCLL	0.0*	Rep Stress Incr	YES	WB	0.46	Horz(CT)	0.26	10	n/a	n/a		
BCDL	10.0	Code	FBC2023/TPI2014	Matrix-MS							Weight: 163 lb	FT = 20%

LUMBER

TOP CHORD 2x4 SP No.2 *Except* 1-3:2x6 SP 2400F 2.0E or 2x6 SP M 26
 BOT CHORD 2x4 SP No.2 *Except* 15-2:2x6 SP No.2, 2-13:2x6 SP 2400F 2.0E or 2x6 SP M 26, 4-12:2x4 SP No.3
 WEBS 2x4 SP No.3

BRACING

TOP CHORD Structural wood sheathing directly applied or 3-6-14 oc purlins, except end verticals.
 BOT CHORD Rigid ceiling directly applied or 10-0-0 oc bracing.

REACTIONS

(size) 1=0-3-8, 10=0-3-8
 Max Horiz 1=146 (LC 12)
 Max Uplift 1=-267 (LC 12), 10=-402 (LC 9)
 Max Grav 1=966 (LC 1), 10=1200 (LC 1)

FORCES

(lb) - Maximum Compression/Maximum Tension
 TOP CHORD 1-2=-565/60, 2-3=-2384/688, 3-4=-2088/638, 4-5=-2108/650, 5-7=-1207/344, 7-8=-56/86, 8-9=-32/12
 BOT CHORD 1-15=-74/134, 2-15=-95/305, 2-14=-691/2187, 13-14=-699/2220, 12-13=0/106, 4-13=-274/141, 11-12=-54/232, 10-11=-158/500, 9-10=-7/12
 WEBS 3-14=-140/603, 3-13=-174/80, 11-13=-306/1012, 8-10=-171/109, 5-11=-714/274, 5-13=-354/969, 7-11=-264/967, 7-10=-1115/375

NOTES

1) Unbalanced roof live loads have been considered for this design.

- 2) Wind: ASCE 7-22; Vult=130mph (3-second gust) Vasd=101mph; TCCL=4.2psf; BCDL=3.0psf; h=18ft; Cat. II; Exp B; Enclosed; MWFRS (envelope) exterior (2) zone and C-C Zone3 0-1-12 to 3-1-12, Zone1 3-1-12 to 9-0-0, Zone2 9-0-0 to 13-2-15, Zone1 13-2-15 to 27-2-4 zone; cantilever right exposed ;C-C for members and forces & MWFRS for reactions shown; Lumber DOL=1.60 plate grip DOL=1.60
- 3) Building Designer / Project engineer responsible for verifying applied roof live load shown covers rain loading requirements specific to the use of this truss component.
- 4) Provide adequate drainage to prevent water ponding.
- 5) This truss has been designed for a 10.0 psf bottom chord live load nonconcurrent with any other live loads.
- 6) * This truss has been designed for a live load of 20.0psf on the bottom chord in all areas where a rectangle 3-06-00 tall by 2-00-00 wide will fit between the bottom chord and any other members.
- 7) Provide mechanical connection (by others) of truss to bearing plate capable of withstanding 267 lb uplift at joint 1 and 402 lb uplift at joint 10.

LOAD CASE(S) Standard

This item has been digitally signed and sealed by O'Regan, Philip, PE on the date indicated here. Printed copies of this document are not considered signed and sealed and the signature must be verified on any electronic copies.

Philip J. O'Regan PE No.58126
 MiTek Inc. DBA MiTek USA FL Cert 6634
 16023 Swingley Ridge Rd. Chesterfield, MO 63017
 Date:

March 10,2026

WARNING - Verify design parameters and READ NOTES ON THIS AND INCLUDED MITEK REFERENCE PAGE MII-7473 rev. 1/2/2023 BEFORE USE.

Design valid for use only with MiTek® connectors. This design is based only upon parameters shown, and is for an individual building component, not a truss system. Before use, the building designer must verify the applicability of design parameters and properly incorporate this design into the overall building design. Bracing indicated is to prevent buckling of individual truss web and/or chord members only. Additional temporary and permanent bracing is always required for stability and to prevent collapse with possible personal injury and property damage. For general guidance regarding the fabrication, storage, delivery, erection and bracing of trusses and truss systems, see **ANSI/TPI1 Quality Criteria and DSB-22** available from Truss Plate Institute (www.tpinst.org) and **BCSI Building Component Safety Information** available from the Structural Building Component Association (www.sbcsccomponents.com)

MiTek®

16023 Swingley Ridge Rd.
 Chesterfield, MO 63017
 314.434.1200 / MiTek-US.com

Job 5240843	Truss T07	Truss Type Hip	Qty 1	Ply 1	Job Reference (optional)	T40398695
----------------	--------------	-------------------	----------	----------	--------------------------	-----------

Builders FirstSource (Lake City,FL), Lake City, FL - 32055,

Run: 8.83 S Jan 22 2026 Print: 8.830 S Jan 22 2026 MiTek Industries, Inc. Mon Mar 09 14:41:41
ID:FRvLwg2TKJD9Rw287C0qRznuSI-RfC?PsB70Hq3NSgPqnL8w3uTXbGKWrCDoi7J4zJC?f

Page: 1

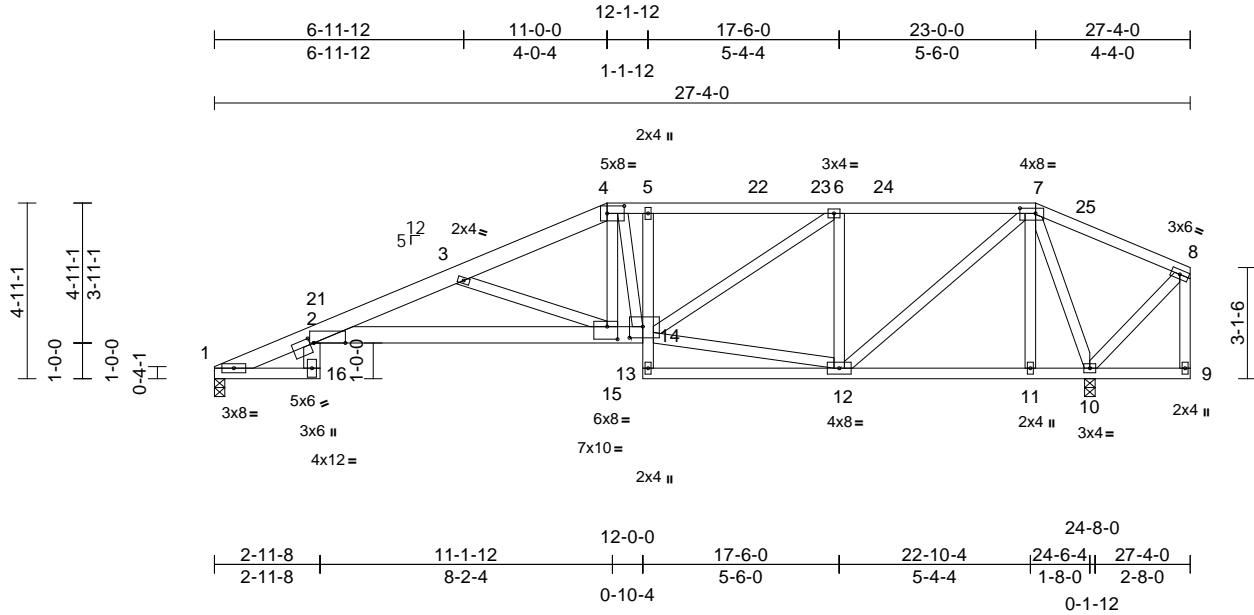

Scale = 1:64.5

Plate Offsets (X, Y): [2:0-10-10,Edge], [2:0-1-5,0-2-3], [4:0-5-12,0-2-8], [7:0-5-4,0-1-12], [14:0-4-8,0-3-12], [15:0-3-8,0-4-4]

Loading	(psf)	Spacing	2-0-0	CSI	DEFL	in	(loc)	l/defl	L/d	PLATES	GRIP	
TCLL (roof)	20.0	Plate Grip DOL	1.25	TC	0.79	Vert(LL)	0.27	2-15	>999	240	MT20	244/190
TCDL	10.0	Lumber DOL	1.25	BC	0.71	Vert(CT)	-0.55	2-15	>531	180		
BCLL	0.0*	Rep Stress Incr	YES	WB	0.52	Horz(CT)	0.24	10	n/a	n/a		
BCDL	10.0	Code	FBC2023/TPI2014	Matrix-MS							Weight: 181 lb	FT = 20%

LUMBER
TOP CHORD 2x4 SP No.2 *Except* 1-4:2x6 SP 2400F 2.0E or 2x6 SP M 26
BOT CHORD 2x4 SP No.2 *Except* 16-2:2x6 SP No.2, 2-14:2x6 SP 2400F 2.0E or 2x6 SP M 26, 5-13:2x4 SP No.3
WEBS 2x4 SP No.3
BRACING
TOP CHORD Structural wood sheathing directly applied or 4-4-5 oc purlins, except end verticals.
BOT CHORD Rigid ceiling directly applied or 10-0-0 oc bracing.
REACTIONS (size) 1=0-3-8, 10=0-3-8
Max Horiz 1=140 (LC 12)
Max Uplift 1=-263 (LC 12), 10=-341 (LC 9)
Max Grav 1=970 (LC 25), 10=1200 (LC 1)
FORCES (lb) - Maximum Compression/Maximum Tension
TOP CHORD 1-2=-568/67, 2-3=-2823/849, 3-4=-1949/545, 4-5=-1650/512, 5-6=-1646/514, 6-7=-1058/325, 7-8=-30/138, 8-9=-24/43
BOT CHORD 1-16=-72/134, 2-16=-93/306, 2-15=-891/2717, 14-15=-493/1755, 13-14=0/99, 5-14=-271/139, 12-13=-28/133, 11-12=-69/281, 10-11=-70/279, 9-10=-8/14
WEBS 3-15=-1072/435, 4-15=-255/1066, 4-14=-391/62, 6-14=-257/688, 7-12=-278/1024, 7-11=0/141, 7-10=-1099/282, 8-10=-137/83, 6-12=-740/270, 12-14=-263/961

- Wind: ASCE 7-22; Vult=130mph (3-second gust) Vasd=101mph; TC DL=4.2psf; BC DL=3.0psf; h=18ft; Cat. II; Exp B; Enclosed; MWFRS (envelope) exterior (2) zone and C-C Zone3 0-1-12 to 3-1-12, Zone1 3-1-12 to 11-0-0, Zone2 11-0-0 to 15-2-15, Zone1 15-2-15 to 23-0-0, Zone3 23-0-0 to 27-2-4 zone; cantilever right exposed ;C-C for members and forces & MWFRS for reactions shown; Lumber DOL=1.60 plate grip DOL=1.60
 - Building Designer / Project engineer responsible for verifying applied roof live load shown covers rain loading requirements specific to the use of this truss component.
 - Provide adequate drainage to prevent water ponding.
 - This truss has been designed for a 10.0 psf bottom chord live load nonconcurrent with any other live loads.
 - * This truss has been designed for a live load of 20.0psf on the bottom chord in all areas where a rectangle 3-06-00 tall by 2-00-00 wide will fit between the bottom chord and any other members.
 - Provide mechanical connection (by others) of truss to bearing plate capable of withstanding 263 lb uplift at joint 1 and 341 lb uplift at joint 10.
- LOAD CASE(S)** Standard

NOTES
1) Unbalanced roof live loads have been considered for this design.

This item has been digitally signed and sealed by ORegan, Philip, PE on the date indicated here. Printed copies of this document are not considered signed and sealed and the signature must be verified on any electronic copies.

Philip J. O'Regan PE No.58126
MiTek Inc. DBA MiTek USA FL Cert 6634
16023 Swingley Ridge Rd. Chesterfield, MO 63017
Date:

March 10,2026

WARNING - Verify design parameters and READ NOTES ON THIS AND INCLUDED MITEK REFERENCE PAGE MII-7473 rev. 1/2/2023 BEFORE USE.

Design valid for use only with MiTek® connectors. This design is based only upon parameters shown, and is for an individual building component, not a truss system. Before use, the building designer must verify the applicability of design parameters and properly incorporate this design into the overall building design. Bracing indicated is to prevent buckling of individual truss web and/or chord members only. Additional temporary and permanent bracing is always required for stability and to prevent collapse with possible personal injury and property damage. For general guidance regarding the fabrication, storage, delivery, erection and bracing of trusses and truss systems, see **ANSI/TPI1 Quality Criteria and DSB-22** available from Truss Plate Institute (www.tpinst.org) and **BCSI Building Component Safety Information** available from the Structural Building Component Association (www.sbcsccomponents.com)

MiTek®
16023 Swingley Ridge Rd.
Chesterfield, MO 63017
314.434.1200 / MiTek-US.com

Job 5240843	Truss T08	Truss Type Hip	Qty 1	Ply 1	Job Reference (optional)	T40398696
----------------	--------------	-------------------	----------	----------	--------------------------	-----------

Builders FirstSource (Lake City,FL), Lake City, FL - 32055,

Run: 8.83 S Jan 22 2026 Print: 8.830 S Jan 22 2026 MiTek Industries, Inc. Mon Mar 09 14:41:42
ID:xnTsHm8KiCV5mrLVkQ_MjFznbuF-RfC?PsB70Hq3NSgPqnL8w3uITXbGKWrCdoi7J4zJC?F

Page: 1

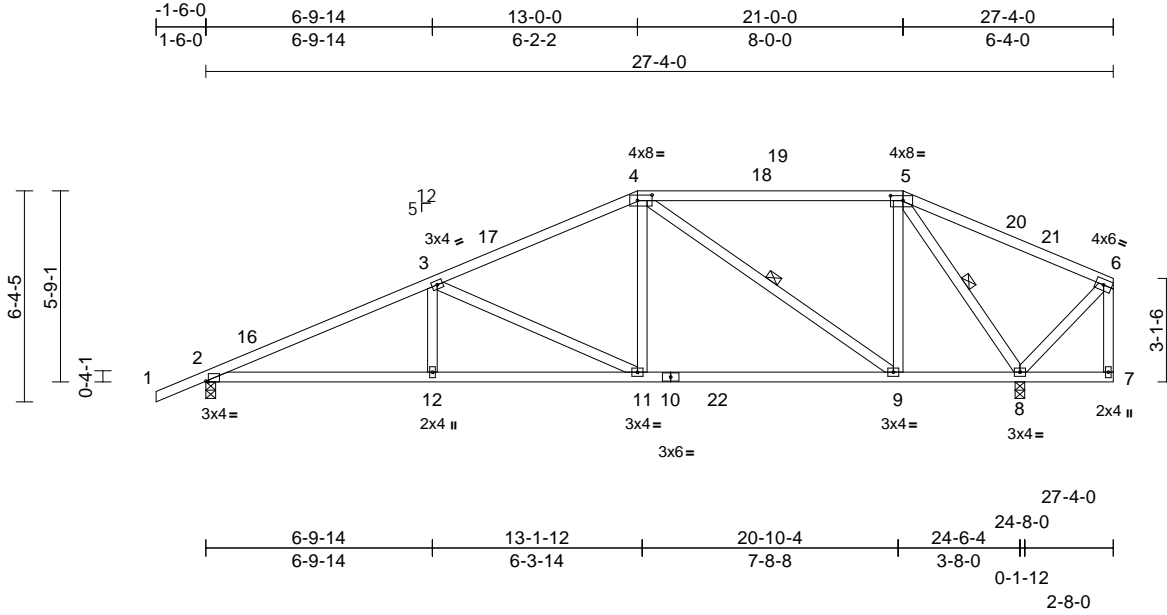

Scale = 1:69.4

Plate Offsets (X, Y): [2:0-0-14,Edge], [4:0-5-4,0-2-0], [5:0-4-8,0-1-12]

Loading	(psf)	Spacing	2-0-0	CSI	DEFL	in	(loc)	l/defl	L/d	PLATES	GRIP	
TCLL (roof)	20.0	Plate Grip DOL	1.25	TC	0.94	Vert(LL)	-0.12	9-11	>999	240	MT20	244/190
TCDL	10.0	Lumber DOL	1.25	BC	0.74	Vert(CT)	-0.24	9-11	>999	180		
BCLL	0.0*	Rep Stress Incr	YES	WB	0.68	Horz(CT)	0.06	8	n/a	n/a		
BCDL	10.0	Code	FBC2023/TPI2014	Matrix-MS							Weight: 148 lb	FT = 20%

LUMBER

TOP CHORD 2x4 SP No.2
BOT CHORD 2x4 SP No.2
WEBS 2x4 SP No.3

BRACING

TOP CHORD Structural wood sheathing directly applied, except end verticals.
BOT CHORD Rigid ceiling directly applied or 7-9-10 oc bracing.
WEBS 1 Row at midpt 4-9, 5-8

REACTIONS

(size) 2=0-3-8, 8=0-3-8
Max Horiz 2=173 (LC 12)
Max Uplift 2=-297 (LC 12), 8=-309 (LC 9)
Max Grav 2=1121 (LC 2), 8=1299 (LC 2)

FORCES

(lb) - Maximum Compression/Maximum Tension
TOP CHORD 1-2=0/35, 2-3=-2074/504, 3-4=-1373/339, 4-5=-609/187, 5-6=-33/193, 6-7=-26/51
BOT CHORD 2-12=-553/1881, 11-12=-553/1881, 9-11=-294/1224, 8-9=-119/592, 7-8=-21/32
WEBS 3-12=0/264, 3-11=-739/287, 4-11=-73/590, 4-9=-762/227, 5-9=-89/671, 5-8=-1282/274, 6-8=-202/111

NOTES

- Unbalanced roof live loads have been considered for this design.
- Wind: ASCE 7-22; Vult=130mph (3-second gust) Vasd=101mph; TC DL=4.2psf; BCDL=3.0psf; h=18ft; Cat. II; Exp B; Enclosed; MWFRS (envelope) exterior (2) zone and C-C Zone3 -1-6-0 to 1-6-0, Zone1 1-6-0 to 13-0-0, Zone2 13-0-0 to 17-2-15, Zone1 17-2-15 to 21-0-0, Zone2 21-0-0 to 25-2-15, Zone1 25-2-15 to 27-2-4 zone; cantilever right exposed ;C-C for members and forces & MWFRS for reactions shown; Lumber DOL=1.60 plate grip DOL=1.60
- Building Designer / Project engineer responsible for verifying applied roof live load shown covers rain loading requirements specific to the use of this truss component.

- Provide adequate drainage to prevent water ponding.
- This truss has been designed for a 10.0 psf bottom chord live load nonconcurrent with any other live loads.
- * This truss has been designed for a live load of 20.0psf on the bottom chord in all areas where a rectangle 3-06-00 tall by 2-00-00 wide will fit between the bottom chord and any other members, with BCDL = 10.0psf.
- Provide mechanical connection (by others) of truss to bearing plate capable of withstanding 309 lb uplift at joint 8 and 297 lb uplift at joint 2.

LOAD CASE(S) Standard

This item has been digitally signed and sealed by ORegan, Philip, PE on the date indicated here. Printed copies of this document are not considered signed and sealed and the signature must be verified on any electronic copies.

Philip J. O'Regan PE No.58126
MiTek Inc. DBA MiTek USA FL Cert 6634
16023 Swingley Ridge Rd. Chesterfield, MO 63017
Date:

March 10,2026

WARNING - Verify design parameters and READ NOTES ON THIS AND INCLUDED MITEK REFERENCE PAGE MII-7473 rev. 1/2/2023 BEFORE USE.

Design valid for use only with MiTek® connectors. This design is based only upon parameters shown, and is for an individual building component, not a truss system. Before use, the building designer must verify the applicability of design parameters and properly incorporate this design into the overall building design. Bracing indicated is to prevent buckling of individual truss web and/or chord members only. Additional temporary and permanent bracing is always required for stability and to prevent collapse with possible personal injury and property damage. For general guidance regarding the fabrication, storage, delivery, erection and bracing of trusses and truss systems, see **ANSI/TPI1 Quality Criteria and DSB-22** available from Truss Plate Institute (www.tpinst.org) and **BCSI Building Component Safety Information** available from the Structural Building Component Association (www.sbcsccomponents.com)

MiTek®

16023 Swingley Ridge Rd.
Chesterfield, MO 63017
314.434.1200 / MiTek-US.com

Job 5240843	Truss T09	Truss Type Hip	Qty 1	Ply 1	Job Reference (optional)	T40398697
----------------	--------------	-------------------	----------	----------	--------------------------	-----------

Builders FirstSource (Lake City,FL), Lake City, FL - 32055,

Run: 8.83 S Jan 22 2026 Print: 8.830 S Jan 22 2026 MiTek Industries, Inc. Mon Mar 09 14:41:42
ID:AQN0FIOSS0xp02pZjZptc_znv8C-RfC?PsB70Hq3NSgPqnL8w3uITXbGKwRCD0i7J4zJC?

Page: 1

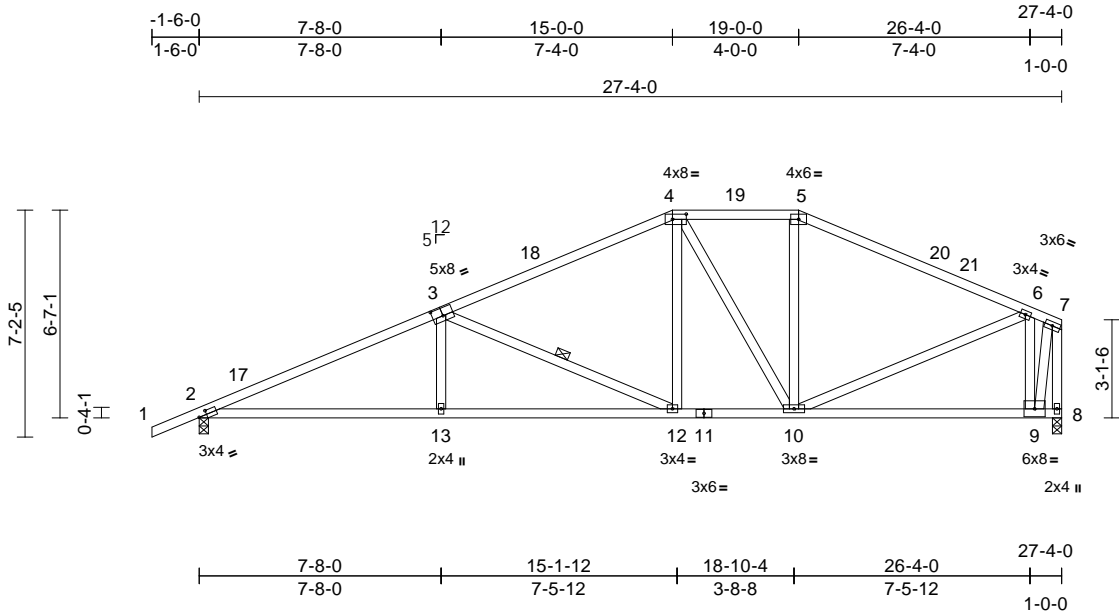

Scale = 1:73

Plate Offsets (X, Y): [2:0-3-0,0-1-8], [3:0-4-0,0-3-0], [4:0-5-4,0-2-0]

Loading	(psf)	Spacing	2-0-0	CSI	DEFL	in	(loc)	l/defl	L/d	PLATES	GRIP	
TCLL (roof)	20.0	Plate Grip DOL	1.25	TC	0.67	Vert(LL)	0.11	13-16	>999	240	MT20	244/190
TCDL	10.0	Lumber DOL	1.25	BC	0.75	Vert(CT)	-0.24	13-16	>999	180		
BCLL	0.0*	Rep Stress Incr	YES	WB	0.51	Horz(CT)	0.06	8	n/a	n/a		
BCDL	10.0	Code	FBC2023/TPI2014	Matrix-MS							Weight: 155 lb	FT = 20%

LUMBER

TOP CHORD 2x4 SP No.2
BOT CHORD 2x4 SP No.2
WEBS 2x4 SP No.3

BRACING

TOP CHORD Structural wood sheathing directly applied or 3-2-14 oc purlins, except end verticals.
BOT CHORD Rigid ceiling directly applied or 7-5-1 oc bracing.
WEBS 1 Row at midpt 3-12

REACTIONS

(size) 2=0-3-8, 8=0-3-8
Max Horiz 2=187 (LC 12)
Max Uplift 2=-320 (LC 12), 8=-234 (LC 13)
Max Grav 2=1180 (LC 1), 8=1085 (LC 1)

FORCES

(lb) - Maximum Compression/Maximum Tension
TOP CHORD 1-2=0/35, 2-4=-2210/550, 4-5=-1021/286, 5-6=-1199/288, 6-7=-252/29, 7-8=-1136/171
BOT CHORD 2-13=-603/1979, 12-13=-603/1979, 10-12=-289/1181, 9-10=-106/389, 8-9=-4/19
WEBS 3-13=0/334, 3-12=-880/345, 4-12=-101/465, 4-10=-385/149, 5-10=-36/214, 6-10=-152/685, 6-9=-1148/431, 7-9=-348/1328

NOTES

- Unbalanced roof live loads have been considered for this design.
- Wind: ASCE 7-22; Vult=130mph (3-second gust) Vasd=101mph; TCDL=4.2psf; BCDL=3.0psf; h=18ft; Cat. II; Exp B; Enclosed; MWFRS (envelope) exterior (2) zone and C-C Zone3 -1-6-0 to 1-6-0, Zone1 1-6-0 to 15-0-0, Zone3 15-0-0 to 19-0-0, Zone2 19-0-0 to 23-2-15, Zone1 23-2-15 to 27-2-4 zone; C-C for members and forces & MWFRS for reactions shown; Lumber DOL=1.60 plate grip DOL=1.60
- Building Designer / Project engineer responsible for verifying applied roof live load shown covers rain loading requirements specific to the use of this truss component.

- Provide adequate drainage to prevent water ponding.
- This truss has been designed for a 10.0 psf bottom chord live load nonconcurrent with any other live loads.
- * This truss has been designed for a live load of 20.0psf on the bottom chord in all areas where a rectangle 3-06-00 tall by 2-00-00 wide will fit between the bottom chord and any other members.
- Provide mechanical connection (by others) of truss to bearing plate capable of withstanding 234 lb uplift at joint 8 and 320 lb uplift at joint 2.

LOAD CASE(S) Standard

This item has been digitally signed and sealed by O'Regan, Philip, PE on the date indicated here. Printed copies of this document are not considered signed and sealed and the signature must be verified on any electronic copies.

Philip J. O'Regan PE No.58126
MiTek Inc. DBA MiTek USA FL Cert 6634
16023 Swingley Ridge Rd. Chesterfield, MO 63017
Date:

March 10,2026

WARNING - Verify design parameters and READ NOTES ON THIS AND INCLUDED MITEK REFERENCE PAGE MII-7473 rev. 1/2/2023 BEFORE USE.

Design valid for use only with MiTek® connectors. This design is based only upon parameters shown, and is for an individual building component, not a truss system. Before use, the building designer must verify the applicability of design parameters and properly incorporate this design into the overall building design. Bracing indicated is to prevent buckling of individual truss web and/or chord members only. Additional temporary and permanent bracing is always required for stability and to prevent collapse with possible personal injury and property damage. For general guidance regarding the fabrication, storage, delivery, erection and bracing of trusses and truss systems, see **ANSI/TPI1 Quality Criteria and DSB-22** available from Truss Plate Institute (www.tpinst.org) and **BCSI Building Component Safety Information** available from the Structural Building Component Association (www.sbcsccomponents.com)

MiTek®

16023 Swingley Ridge Rd.
Chesterfield, MO 63017
314.434.1200 / MiTek-US.com

Job 5240843	Truss T10	Truss Type Common	Qty 3	Ply 1	Job Reference (optional)	T40398698
----------------	--------------	----------------------	----------	----------	--------------------------	-----------

Builders FirstSource (Lake City,FL), Lake City, FL - 32055,

Run: 8.83 S Jan 22 2026 Print: 8.830 S Jan 22 2026 MiTek Industries, Inc. Mon Mar 09 14:41:42

Page: 1

ID:Bn085pQmN_elj6puCwroZvzv6t-RfC?PsB70Hq3NSgPqnL8w3uITXbGKWRcDoi7J4zJC?#f

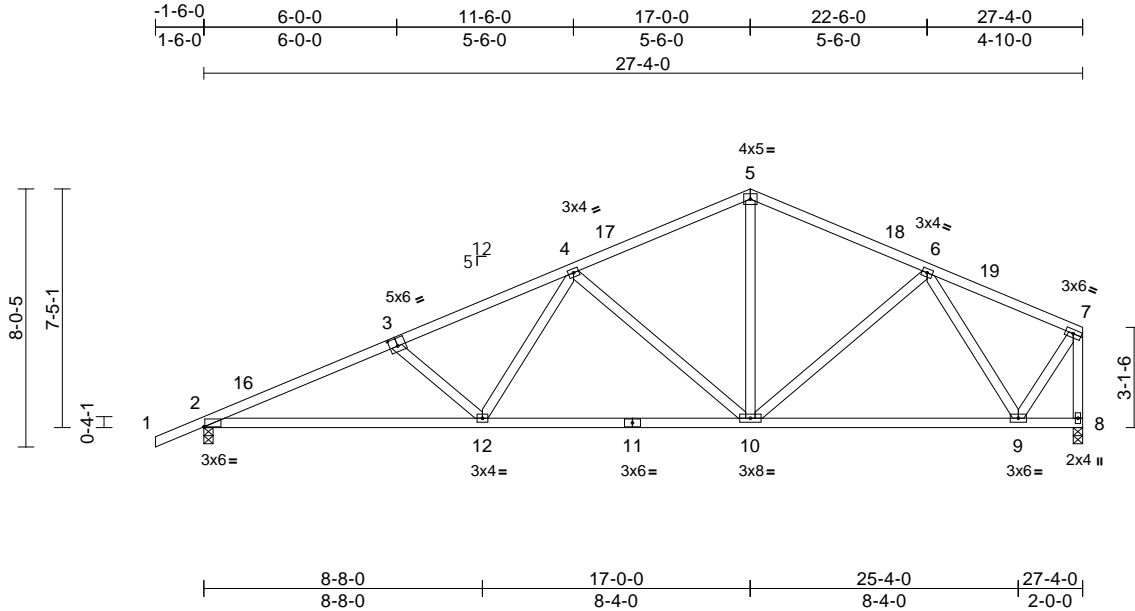

Scale = 1:71.7

Plate Offsets (X, Y): [2:0-0-6,Edge], [3:0-3-0,0-3-0]

Loading	(psf)	Spacing	2-0-0	CSI	DEFL	in	(loc)	l/defl	L/d	PLATES	GRIP	
TCLL (roof)	20.0	Plate Grip DOL	1.25	TC	0.41	Vert(LL)	-0.12	12-15	>999	240	MT20	244/190
TCDL	10.0	Lumber DOL	1.25	BC	0.82	Vert(CT)	-0.28	12-15	>999	180		
BCLL	0.0*	Rep Stress Incr	YES	WB	0.72	Horz(CT)	0.06	8	n/a	n/a		
BCDL	10.0	Code	FBC2023/TPI2014	Matrix-MS							Weight: 148 lb	FT = 20%

LUMBER

TOP CHORD 2x4 SP No.2
 BOT CHORD 2x4 SP No.2
 WEBS 2x4 SP No.3

BRACING

TOP CHORD Structural wood sheathing directly applied or 3-5-11 oc purlins, except end verticals.
 BOT CHORD Rigid ceiling directly applied or 7-3-6 oc bracing.

REACTIONS

(size) 2=0-3-8, 8=0-3-8
 Max Horiz 2=201 (LC 12)
 Max Uplift 2=-317 (LC 12), 8=-230 (LC 13)
 Max Grav 2=1180 (LC 1), 8=1085 (LC 1)

FORCES

(lb) - Maximum Compression/Maximum Tension
 TOP CHORD 1-2=0/35, 2-4=-2234/570, 4-5=-1150/301, 5-6=-1150/317, 6-7=-605/131, 7-8=-1109/217
 BOT CHORD 2-12=-648/2028, 10-12=-441/1513, 9-10=-189/893, 8-9=-11/15
 WEBS 7-9=-149/927, 3-12=-362/206, 4-12=-111/528, 4-10=-692/299, 5-10=-122/534, 6-10=-36/231, 6-9=-741/202

NOTES

- Unbalanced roof live loads have been considered for this design.
- Wind: ASCE 7-22; Vult=130mph (3-second gust) Vasd=101mph; TC DL=4.2psf; BC DL=3.0psf; h=18ft; Cat. II; Exp B; Enclosed; MWFRS (envelope) exterior (2) zone and C-C Zone3 -1-6-0 to 1-6-0, Zone1 1-6-0 to 17-0-0, Zone2 17-0-0 to 21-2-15, Zone1 21-2-15 to 27-2-4 zone;C-C for members and forces & MWFRS for reactions shown; Lumber DOL=1.60 plate grip DOL=1.60
- Building Designer / Project engineer responsible for verifying applied roof live load shown covers rain loading requirements specific to the use of this truss component.
- This truss has been designed for a 10.0 psf bottom chord live load nonconcurrent with any other live loads.

- * This truss has been designed for a live load of 20.0psf on the bottom chord in all areas where a rectangle 3-06-00 tall by 2-00-00 wide will fit between the bottom chord and any other members.
- Provide mechanical connection (by others) of truss to bearing plate capable of withstanding 230 lb uplift at joint 8 and 317 lb uplift at joint 2.

LOAD CASE(S) Standard

This item has been digitally signed and sealed by O'Regan, Philip, PE on the date indicated here. Printed copies of this document are not considered signed and sealed and the signature must be verified on any electronic copies.

Philip J. O'Regan PE No.58126
 MiTek Inc. DBA MiTek USA FL Cert 6634
 16023 Swingley Ridge Rd. Chesterfield, MO 63017
 Date:

March 10,2026

WARNING - Verify design parameters and READ NOTES ON THIS AND INCLUDED MITEK REFERENCE PAGE MII-7473 rev. 1/2/2023 BEFORE USE.

Design valid for use only with MiTek® connectors. This design is based only upon parameters shown, and is for an individual building component, not a truss system. Before use, the building designer must verify the applicability of design parameters and properly incorporate this design into the overall building design. Bracing indicated is to prevent buckling of individual truss web and/or chord members only. Additional temporary and permanent bracing is always required for stability and to prevent collapse with possible personal injury and property damage. For general guidance regarding the fabrication, storage, delivery, erection and bracing of trusses and truss systems, see **ANSI/TPI1 Quality Criteria and DSB-22** available from Truss Plate Institute (www.tpinst.org) and **BCSI Building Component Safety Information** available from the Structural Building Component Association (www.sbcsccomponents.com)

MiTek®

16023 Swingley Ridge Rd.
 Chesterfield, MO 63017
 314.434.1200 / MiTek-US.com

Job 5240843	Truss T11	Truss Type Roof Special Girder	Qty 1	Ply 1	Job Reference (optional) T40398699
----------------	--------------	-----------------------------------	----------	----------	---------------------------------------

Builders FirstSource (Lake City,FL), Lake City, FL - 32055,

Run: 8.83 S Jan 22 2026 Print: 8.830 S Jan 22 2026 MiTek Industries, Inc. Mon Mar 09 14:41:43
ID:xvisEaB9FDRGaq?hJdC6znui3-RfC?PsB70Hq3NSgPqnL8w3uITxBGKwCDoI7J4zJC?r

Page: 1

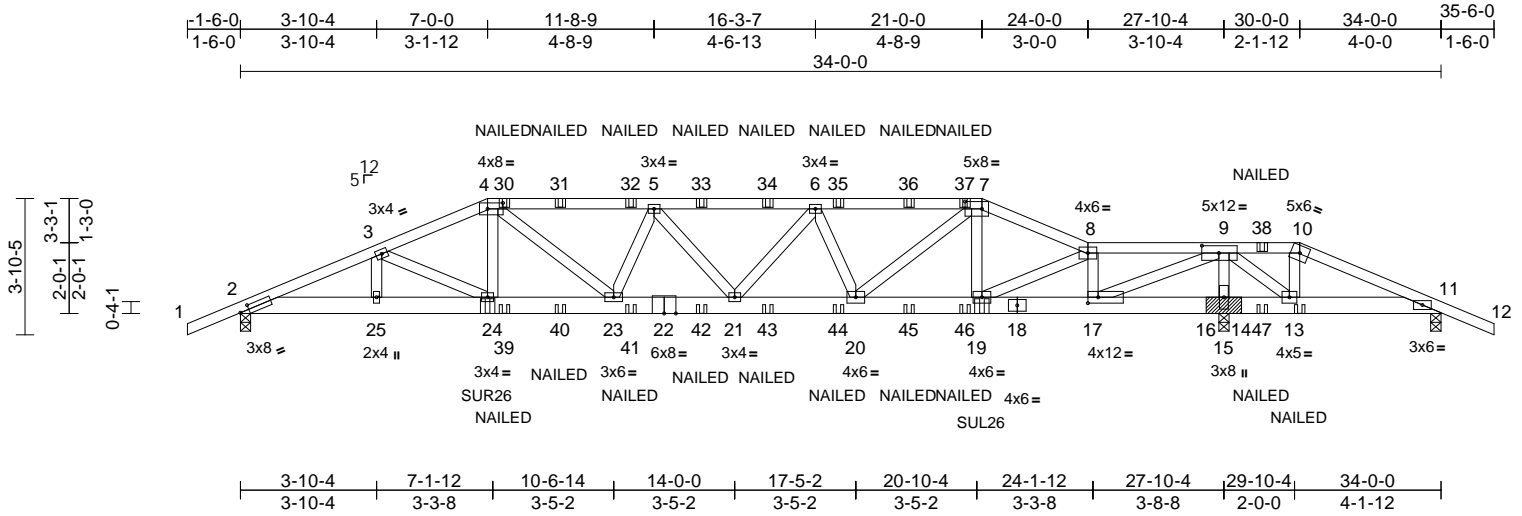

Scale = 1:65.2
Plate Offsets (X, Y): [2:0-3-1,0-1-8], [4:0-5-4,0-2-0], [7:0-5-12,0-2-8], [9:0-5-12,0-2-8], [17:0-3-8,0-2-0]

Loading	(psf)	Spacing	2-0-0	CSI	DEFL	in	(loc)	l/defl	L/d	PLATES	GRIP	
TCLL (roof)	20.0	Plate Grip DOL	1.25	TC	0.96	Vert(LL)	0.25	21-23	>999	240	MT20	244/190
TCDL	10.0	Lumber DOL	1.25	BC	0.98	Vert(CT)	-0.49	21-23	>681	180		
BCLL	0.0*	Rep Stress Incr	NO	WB	0.79	Horz(CT)	0.08	15	n/a	n/a		
BCDL	10.0	Code	FBC2023/TPI2014	Matrix-MS							Weight: 203 lb	FT = 20%

LUMBER
TOP CHORD 2x4 SP No.2 *Except* 4-7:2x4 SP No.1
BOT CHORD 2x6 SP No.2
WEBS 2x4 SP No.3 *Except* 9-17:2x4 SP No.1

BRACING
TOP CHORD Structural wood sheathing directly applied.
BOT CHORD Rigid ceiling directly applied or 3-2-14 oc bracing.

REACTIONS (size)
2=0-3-8, 11=0-3-8, 15=(0-3-8 + bearing block), (req. 0-4-8)
Max Horiz 2=59 (LC 12)
Max Uplift 2=-652 (LC 8), 11=-868 (LC 21), 15=-1340 (LC 5)
Max Grav 2=1989 (LC 1), 11=278 (LC 8), 15=3819 (LC 1)

FORCES (lb) - Maximum Compression/Maximum Tension
TOP CHORD 1-2=0/35, 2-3=-4492/1469, 3-4=-4299/1489, 4-5=-4722/1644, 5-6=-4775/1664, 6-7=-4112/1449, 7-8=-3013/1080, 8-9=-778/298, 9-10=-807/2547, 10-11=-885/2686, 11-12=0/35
BOT CHORD 2-25=-1346/4122, 24-25=-1346/4122, 23-24=-1311/3980, 21-23=-1632/4897, 20-21=-1495/4491, 19-20=-900/2748, 17-19=-280/974, 15-17=-3795/1329, 13-15=-3795/1329, 11-13=-2451/849
WEBS 4-24=-213/645, 7-19=-398/152, 8-19=-735/2078, 8-17=-2229/799, 9-13=-584/1610, 10-13=-1131/376, 3-24=-194/192, 3-25=-16/77, 7-20=-576/1786, 4-23=-314/1018, 5-23=-517/234, 5-21=-217/121, 6-21=-116/476, 6-20=-1048/416, 9-15=-3327/1190, 9-17=-1678/4969

- 2x6 SP No.2 bearing block 12" long at jt. 15 attached to front face with 3 rows of 10d (0.131"x3") nails spaced 3" o.c. 12 Total fasteners. Bearing is assumed to be SP No.2.
- Unbalanced roof live loads have been considered for this design.
- Wind: ASCE 7-22; Vult=130mph (3-second gust) Vasd=101mph; TC DL=4.2psf; BC DL=3.0psf; h=18ft; Cat II; Exp B; Enclosed; MWFRS (envelope) exterior (2) zone; porch right exposed; Lumber DOL=1.60 plate grip DOL=1.60
- Building Designer / Project engineer responsible for verifying applied roof live load shown covers rain loading requirements specific to the use of this truss component.
- Provide adequate drainage to prevent water ponding.
- This truss has been designed for a 10.0 psf bottom chord live load nonconcurrent with any other live loads.
- * This truss has been designed for a live load of 20.0psf on the bottom chord in all areas where a rectangle 3-06-00 tall by 2-00-00 wide will fit between the bottom chord and any other members.
- Provide mechanical connection (by others) of truss to bearing plate capable of withstanding 868 lb uplift at joint 11, 652 lb uplift at joint 2 and 1340 lb uplift at joint 15.
- Use Simpson Strong-Tie SUR26 (6-10dx1 1/2 Girder, 6-10dx1 1/2 Truss, Single Ply Girder) or equivalent at 7-0-0 from the left end to connect truss(es) to back face of bottom chord, skewed 45.0 deg.to the right, sloping 0.0 deg. down.
- Use Simpson Strong-Tie SUL26 (6-16d Girder, 6-10dx1 1/2 Truss) or equivalent at 21-0-0 from the left end to connect truss(es) to back face of bottom chord, skewed 45.0 deg.to the left, sloping 0.0 deg. down.
- Fill all nail holes where hanger is in contact with lumber.
- "NAILED" indicates 3-10d (0.148"x3") or 3-12d (0.148"x3.25") toe-nails per NDS guidelines.
- In the LOAD CASE(S) section, loads applied to the face of the truss are noted as front (F) or back (B).

LOAD CASE(S) Standard
1) Dead + Roof Live (balanced): Lumber Increase=1.25, Plate Increase=1.25
Uniform Loads (lb/ft)
Vert: 1-4=-60, 4-7=-60, 7-8=-60, 8-10=-60, 10-12=-60, 2-11=-20
Concentrated Loads (lb)
Vert: 24=-283 (B), 19=-283 (B), 13=-31 (B), 30=-120 (B), 31=-120 (B), 32=-120 (B), 33=-120 (B), 34=-120 (B), 35=-120 (B), 36=-120 (B), 37=-120 (B), 38=-35 (B), 39=-68 (B), 40=-68 (B), 41=-68 (B), 42=-68 (B), 43=-68 (B), 44=-68 (B), 45=-68 (B), 46=-68 (B), 47=-26 (B)

This item has been digitally signed and sealed by O'Regan, Philip, PE on the date indicated here. Printed copies of this document are not considered signed and sealed and the signature must be verified on any electronic copies.

Philip J. O'Regan PE No.58126
MiTek Inc. DBA MiTek USA FL Cert 6364
16023 Swingley Ridge Rd. Chesterfield, MO 63017
Date:

March 10,2026

WARNING - Verify design parameters and READ NOTES ON THIS AND INCLUDED MITEK REFERENCE PAGE MII-7473 rev. 1/2/2023 BEFORE USE.

Design valid for use only with MiTek® connectors. This design is based only upon parameters shown, and is for an individual building component, not a truss system. Before use, the building designer must verify the applicability of the design parameters and properly incorporate this design into the overall building design. Bracing indicated is to prevent buckling of individual truss web and/or chord members only. Additional temporary and permanent bracing is always required for stability and to prevent collapse with possible personal injury and property damage. For general guidance regarding the fabrication, storage, delivery, erection and bracing of trusses and truss systems, see **ANSI/TPI1 Quality Criteria and DSB-22** available from Truss Plate Institute (www.tpinst.org) and **BCSI Building Component Safety Information** available from the Structural Building Component Association (www.sbcsccomponents.com)

MiTek®
16023 Swingley Ridge Rd.
Chesterfield, MO 63017
314.434.1200 / MiTek-US.com

Job 5240843	Truss T13	Truss Type Roof Special	Qty 1	Ply 1	Job Reference (optional) T40398701
----------------	--------------	----------------------------	----------	----------	---------------------------------------

Builders FirstSource (Lake City,FL), Lake City, FL - 32055,

Run: 8.83 S Jan 22 2026 Print: 8.830 S Jan 22 2026 MiTek Industries, Inc. Mon Mar 09 14:41:44
ID:mVxshojZzSs?JuNSY8cMYNznuva-RfC?PsB70Hq3NSgPqnL8w3ulTXbGKWRcDoi7J4zJC?#

Page: 1

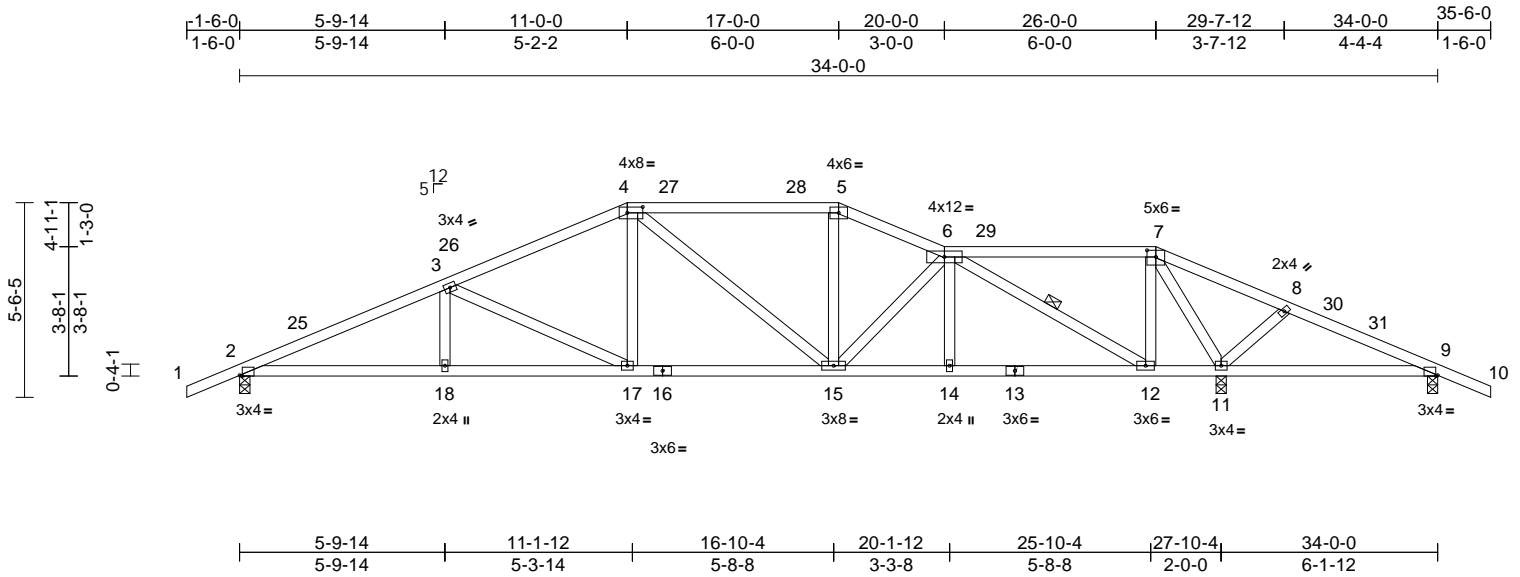

Scale = 1:65.4

Plate Offsets (X, Y): [2:0-0-14,Edge], [4:0-5-4,0-2-0], [7:0-3-0,0-2-4], [9:0-0-10,Edge]

Loading	(psf)	Spacing	2-0-0	CSI	DEFL	in	(loc)	l/defl	L/d	PLATES	GRIP	
TCLL (roof)	20.0	Plate Grip DOL	1.25	TC	0.55	Vert(LL)	-0.09	17	>999	240	MT20	244/190
TCDL	10.0	Lumber DOL	1.25	BC	0.57	Vert(CT)	-0.20	15-17	>999	180		
BCLL	0.0*	Rep Stress Incr	YES	WB	0.59	Horz(CT)	0.06	11	n/a	n/a		
BCDL	10.0	Code	FBC2023/TPI2014	Matrix-MS							Weight: 178 lb	FT = 20%

LUMBER

TOP CHORD 2x4 SP No.2
BOT CHORD 2x4 SP No.2
WEBS 2x4 SP No.3

BRACING

TOP CHORD Structural wood sheathing directly applied or 3-9-4 oc purlins.
BOT CHORD Rigid ceiling directly applied or 6-0-0 oc bracing.

WEBS 1 Row at midpt 6-12

REACTIONS

(size) 2=0-3-8, 9=0-3-8, 11=0-3-8
Max Horiz 2=87 (LC 16)
Max Uplift 2=-267 (LC 12), 9=-199 (LC 25), 11=-480 (LC 9)
Max Grav 2=1107 (LC 1), 9=38 (LC 12), 11=1895 (LC 1)

FORCES

(lb) - Maximum Compression/Maximum Tension
TOP CHORD 1-2=0/35, 2-3=-2115/465, 3-4=-1560/388, 4-5=-1256/359, 5-6=-1386/374, 6-7=-6/154, 7-8=-209/1155, 8-9=-177/959, 9-10=0/35
BOT CHORD 2-18=-421/1904, 17-18=-421/1904, 15-17=-222/1392, 14-15=-245/1295, 12-14=-244/1299, 11-12=-184/119, 9-11=-834/211
WEBS 3-17=-580/240, 4-17=-65/412, 4-15=-276/97, 5-15=-36/299, 6-15=-124/114, 6-14=0/177, 6-12=-1634/383, 7-12=-136/867, 7-11=-1813/392, 8-11=-264/155, 3-18=0/223

NOTES

1) Unbalanced roof live loads have been considered for this design.

- 2) Wind: ASCE 7-22; Vult=130mph (3-second gust) Vasd=101mph; TCDL=4.2psf; BCDL=3.0psf; h=18ft; Cat. II; Exp B; Enclosed; MWFRS (envelope) exterior (2) zone and C-C Zone3 -1-6-0 to 1-10-13, Zone1 1-10-13 to 11-0-0, Zone2 11-0-0 to 15-9-11, Zone1 15-9-11 to 17-0-0, Zone3 17-0-0 to 20-0-0, Zone1 20-0-0 to 26-0-0, Zone2 26-0-0 to 30-9-11, Zone1 30-9-11 to 35-6-0 zone; porch right exposed; C-C for members and forces & MWFRS for reactions shown; Lumber DOL=1.60 plate grip DOL=1.60
- 3) Building Designer / Project engineer responsible for verifying applied roof live load shown covers rain loading requirements specific to the use of this truss component.
- 4) Provide adequate drainage to prevent water ponding.
- 5) This truss has been designed for a 10.0 psf bottom chord live load nonconcurrent with any other live loads.
- 6) * This truss has been designed for a live load of 20.0psf on the bottom chord in all areas where a rectangle 3-06-00 tall by 2-00-00 wide will fit between the bottom chord and any other members.
- 7) Provide mechanical connection (by others) of truss to bearing plate capable of withstanding 199 lb uplift at joint 9, 480 lb uplift at joint 11 and 267 lb uplift at joint 2.

LOAD CASE(S) Standard

This item has been digitally signed and sealed by O'Regan, Philip, PE on the date indicated here. Printed copies of this document are not considered signed and sealed and the signature must be verified on any electronic copies.

Philip J. O'Regan PE No.58126
MiTek Inc. DBA MiTek USA FL Cert 6634
16023 Swingley Ridge Rd. Chesterfield, MO 63017
Date:

March 10, 2026

WARNING - Verify design parameters and READ NOTES ON THIS AND INCLUDED MITEK REFERENCE PAGE MII-7473 rev. 1/2023 BEFORE USE.

Design valid for use only with MiTek® connectors. This design is based only upon parameters shown, and is for an individual building component, not a truss system. Before use, the building designer must verify the applicability of design parameters and properly incorporate this design into the overall building design. Bracing indicated is to prevent buckling of individual truss web and/or chord members only. Additional temporary and permanent bracing is always required for stability and to prevent collapse with possible personal injury and property damage. For general guidance regarding the fabrication, storage, delivery, erection and bracing of trusses and truss systems, see **ANSI/TPI1 Quality Criteria and DSB-22** available from Truss Plate Institute (www.tpinst.org) and **BCSI Building Component Safety Information** available from the Structural Building Component Association (www.sbcsccomponents.com)

MiTek®

16023 Swingley Ridge Rd.
Chesterfield, MO 63017
314.434.1200 / MiTek-US.com

Job 5240843	Truss T15	Truss Type Roof Special	Qty 1	Ply 1	Job Reference (optional)	T40398703
----------------	--------------	----------------------------	----------	----------	--------------------------	-----------

Builders FirstSource (Lake City,FL), Lake City, FL - 32055,

Run: 8.83 S Jan 22 2026 Print: 8.830 S Jan 22 2026 MiTek Industries, Inc. Mon Mar 09 14:41:44
ID:asnGwclMRoedKcwfyTp5fOznujC-RfC?PsB70Hq3NSgPqnL8w3uITXbGKwRCDoi7J4zJC?f

Page: 1

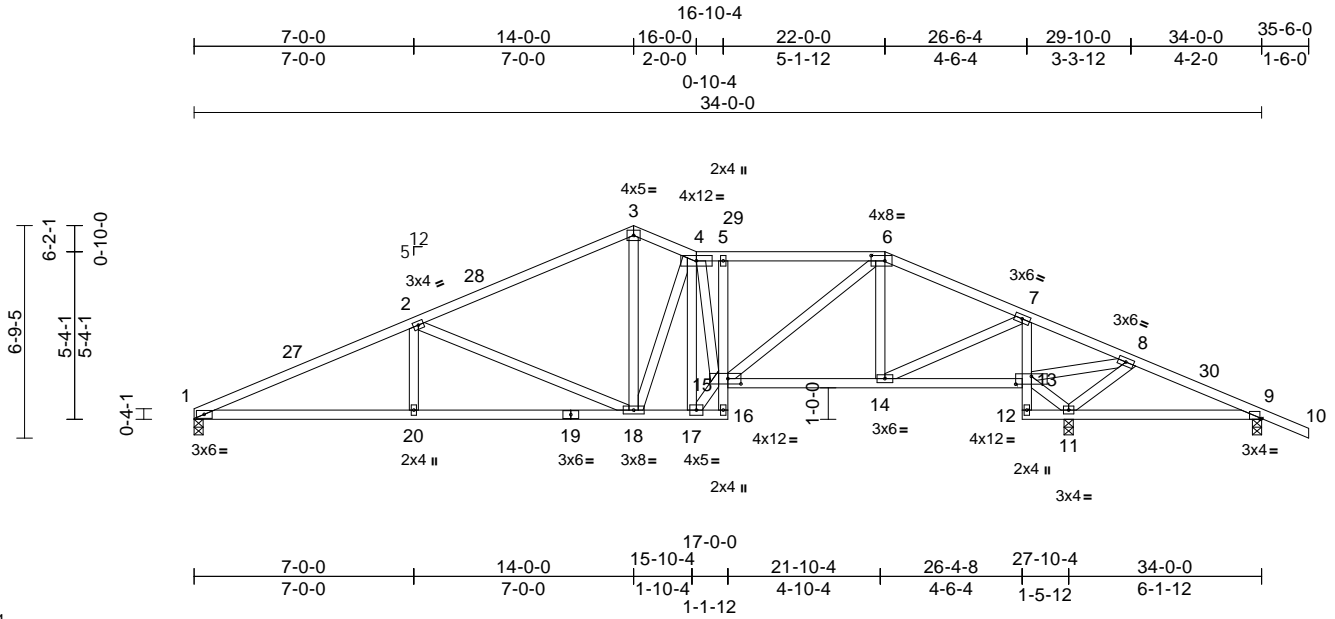

Scale = 1:73.4

Plate Offsets (X, Y): [6:0-5-4,0-2-0], [9:0-0-10,Edge], [13:0-6-0,0-3-0], [15:0-5-0,0-2-0]

Loading	(psf)	Spacing	2-0-0	CSI	DEFL	in	(loc)	l/defl	L/d	PLATES	GRIP	
TCLL (roof)	20.0	Plate Grip DOL	1.25	TC	0.58	Vert(LL)	-0.10	20-23	>999	240	MT20	244/190
TCDL	10.0	Lumber DOL	1.25	BC	0.70	Vert(CT)	-0.23	18-20	>999	180		
BCLL	0.0*	Rep Stress Incr	YES	WB	0.92	Horz(CT)	0.07	11	n/a	n/a		
BCDL	10.0	Code	FBC2023/TPI2014	Matrix-MS							Weight: 197 lb	FT = 20%

LUMBER

TOP CHORD 2x4 SP No.2
 BOT CHORD 2x4 SP No.2 *Except* 16-5,7-12:2x4 SP No.3
 WEBS 2x4 SP No.3

BRACING

TOP CHORD Structural wood sheathing directly applied or 3-6-1 oc purlins.
 BOT CHORD Rigid ceiling directly applied or 6-0-0 oc bracing.

REACTIONS

(size) 1=0-3-8, 9=0-3-8, 11=0-3-8
 Max Horiz 1=-118 (LC 13)
 Max Uplift 1=-254 (LC 12), 9=-147 (LC 25), 11=-428 (LC 13)
 Max Grav 1=1018 (LC 1), 9=35 (LC 12), 11=1882 (LC 1)

FORCES

(lb) - Maximum Compression/Maximum Tension
 TOP CHORD 1-2=-2083/503, 2-3=-1302/321, 3-4=-1208/340, 4-5=-1427/380, 5-6=-1457/385, 6-7=-921/267, 7-8=-107/611, 8-9=-149/909, 9-10=0/35
 BOT CHORD 1-20=-488/1883, 18-20=-488/1883, 17-18=-190/1208, 16-17=-25/111, 15-16=-23/15, 5-15=-285/164, 14-15=-66/780, 13-14=-497/172, 12-13=-104/62, 7-13=-1392/340, 11-12=-49/9, 9-11=-790/164
 WEBS 4-17=-1058/145, 15-17=-242/1594, 4-15=-170/915, 6-15=-209/860, 6-14=-467/135, 7-14=-255/1423, 11-13=-1819/444, 8-11=-802/242, 8-13=-181/895, 2-20=0/305, 2-18=-835/332, 3-18=-151/619, 4-18=-311/159

NOTES

1) Unbalanced roof live loads have been considered for this design.

- 2) Wind: ASCE 7-22; Vult=130mph (3-second gust) Vasd=101mph; TC DL=4.2psf; BC DL=3.0psf; h=18ft; Cat. II; Exp B; Enclosed; MWFRS (envelope) exterior (2) zone and C-C Zone3 0-0-0 to 3-4-13, Zone1 3-4-13 to 14-0-0, Zone3 14-0-0 to 16-0-0, Zone1 16-0-0 to 22-0-0, Zone2 22-0-0 to 26-6-4, Zone1 26-6-4 to 35-6-0 zone; porch right exposed; C-C for members and forces & MWFRS for reactions shown; Lumber DOL=1.60 plate grip DOL=1.60
- 3) Building Designer / Project engineer responsible for verifying applied roof live load shown covers rain loading requirements specific to the use of this truss component.
- 4) Provide adequate drainage to prevent water ponding.
- 5) This truss has been designed for a 10.0 psf bottom chord live load nonconcurrent with any other live loads.
- 6) * This truss has been designed for a live load of 20.0psf on the bottom chord in all areas where a rectangle 3-06-00 tall by 2-00-00 wide will fit between the bottom chord and any other members.
- 7) Provide mechanical connection (by others) of truss to bearing plate capable of withstanding 254 lb uplift at joint 1, 147 lb uplift at joint 9 and 428 lb uplift at joint 11.

LOAD CASE(S) Standard

This item has been digitally signed and sealed by O'Regan, Philip, PE on the date indicated here. Printed copies of this document are not considered signed and sealed and the signature must be verified on any electronic copies.

Philip J. O'Regan PE No.58126
 MiTek Inc. DBA MiTek USA FL Cert 6634
 16023 Swingley Ridge Rd. Chesterfield, MO 63017
 Date:

March 10, 2026

WARNING - Verify design parameters and READ NOTES ON THIS AND INCLUDED MITEK REFERENCE PAGE MII-7473 rev. 1/2/2023 BEFORE USE.

Design valid for use only with MiTek® connectors. This design is based only upon parameters shown, and is for an individual building component, not a truss system. Before use, the building designer must verify the applicability of the design parameters and properly incorporate this design into the overall building design. Bracing indicated is to prevent buckling of individual truss web and/or chord members only. Additional temporary and permanent bracing is always required for stability and to prevent collapse with possible personal injury and property damage. For general guidance regarding the fabrication, storage, delivery, erection and bracing of trusses and truss systems, see **ANSI/TPI1 Quality Criteria and DSB-22** available from Truss Plate Institute (www.tpinst.org) and **BCSI Building Component Safety Information** available from the Structural Building Component Association (www.sbcsccomponents.com)

MiTek®

16023 Swingley Ridge Rd.
 Chesterfield, MO 63017
 314.434.1200 / MiTek-US.com

Job 5240843	Truss T18	Truss Type Roof Special	Qty 2	Ply 1	Job Reference (optional) T40398706
----------------	--------------	----------------------------	----------	----------	---------------------------------------

Builders FirstSource (Lake City,FL), Lake City, FL - 32055,

Run: 8.83 S Jan 22 2026 Print: 8.830 S Jan 22 2026 MiTek Industries, Inc. Mon Mar 09 14:41:46
ID:sM8D5t9HOWJLYxpGOZEkkznusQ-RfC?PsB70Hq3NSgPqnL8w3uITXbGKWrCdoi7J4zJC?f

Page: 1

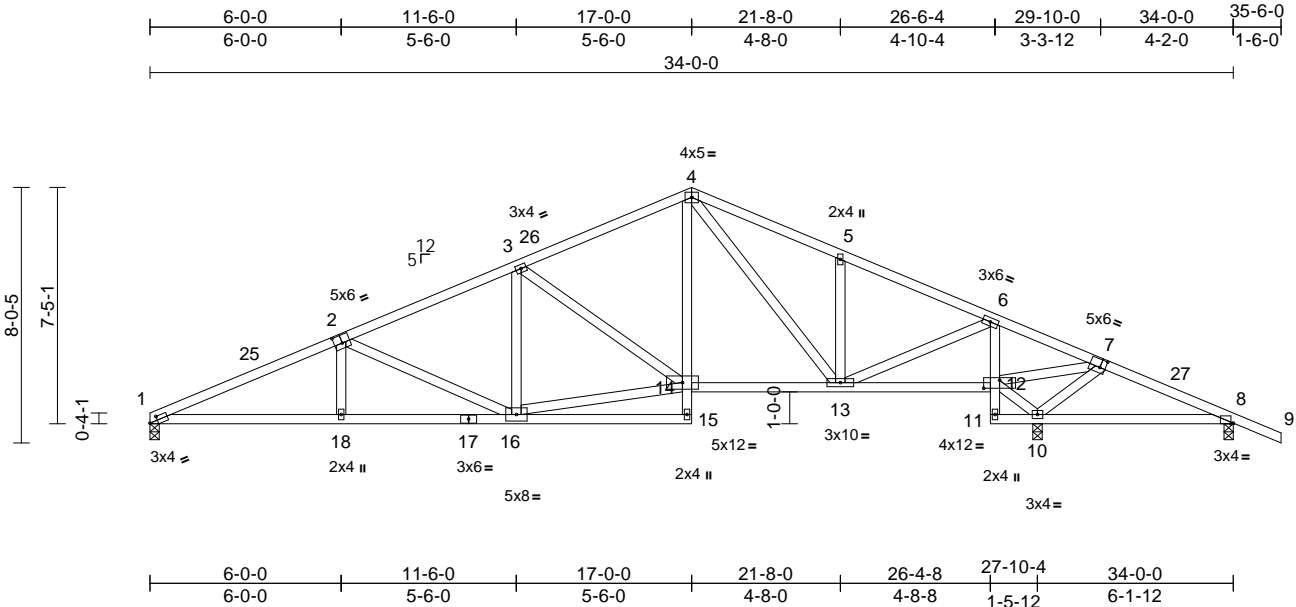

Scale = 1:72.3
Plate Offsets (X, Y): [1:0-3-0,0-1-8], [2:0-3-0,0-3-0], [7:0-2-0,0-3-0], [8:0-0-14,Edge], [12:0-6-0,0-3-0]

Loading	(psf)	Spacing	2-0-0	CSI	DEFL	in	(loc)	l/defl	L/d	PLATES	GRIP	
TCLL (roof)	20.0	Plate Grip DOL	1.25	TC	0.38	Vert(LL)	-0.08	16-18	>999	240	MT20	244/190
TCDL	10.0	Lumber DOL	1.25	BC	0.65	Vert(CT)	-0.17	15-16	>999	180		
BCLL	0.0*	Rep Stress Incr	YES	WB	0.52	Horz(CT)	0.06	10	n/a	n/a		
BCDL	10.0	Code	FBC2023/TPI2014	Matrix-MS							Weight: 193 lb	FT = 20%

LUMBER
TOP CHORD 2x4 SP No.2
BOT CHORD 2x4 SP No.2 *Except* 15-4,6-11:2x4 SP No.3
WEBS 2x4 SP No.3

BRACING
TOP CHORD Structural wood sheathing directly applied or 3-6-11 oc purlins.
BOT CHORD Rigid ceiling directly applied or 6-0-0 oc bracing.

REACTIONS (size) 1=0-3-8, 8=0-3-8, 10=0-3-8
Max Horiz 1=-139 (LC 13)
Max Uplift 1=-270 (LC 12), 8=-120 (LC 25), 10=-378 (LC 13)
Max Grav 1=1033 (LC 1), 8=74 (LC 26), 10=1797 (LC 1)

FORCES (lb) - Maximum Compression/Maximum Tension
TOP CHORD 1-3=-2166/557, 3-4=-1160/314, 4-5=-1035/328, 5-6=-1033/240, 6-8=-157/744, 8-9=0/35
BOT CHORD 1-18=-565/1963, 16-18=-565/1964, 15-16=-9/71, 14-15=0/103, 4-14=-174/637, 13-14=-151/995, 12-13=-296/144, 11-12=-102/62, 6-12=-1280/293, 10-11=-45/9, 8-10=-638/171
WEBS 2-16=-604/239, 3-16=0/234, 14-16=-345/1368, 3-14=-535/236, 4-13=-263/70, 6-13=-267/1309, 10-12=-1630/378, 5-13=-305/188, 7-10=-831/222, 7-12=-149/945, 2-18=0/231

- Wind: ASCE 7-22; Vult=130mph (3-second gust) Vasd=101mph; TCDL=4.2psf; BCDL=3.0psf; h=18ft; Cat. II; Exp B; Enclosed; MWFRS (envelope) exterior (2) zone and C-C Zone3 0-0-0 to 3-4-13, Zone1 3-4-13 to 17-0-0, Zone2 17-0-0 to 21-8-0, Zone1 21-8-0 to 35-6-0 zone; porch right exposed;C-C for members and forces & MWFRS for reactions shown; Lumber DOL=1.60 plate grip DOL=1.60
- Building Designer / Project engineer responsible for verifying applied roof live load shown covers rain loading requirements specific to the use of this truss component.
- This truss has been designed for a 10.0 psf bottom chord live load nonconcurrent with any other live loads.
- * This truss has been designed for a live load of 20.0psf on the bottom chord in all areas where a rectangle 3-06-00 tall by 2-00-00 wide will fit between the bottom chord and any other members.
- Provide mechanical connection (by others) of truss to bearing plate capable of withstanding 270 lb uplift at joint 1, 120 lb uplift at joint 8 and 378 lb uplift at joint 10.

LOAD CASE(S) Standard

NOTES
1) Unbalanced roof live loads have been considered for this design.

This item has been digitally signed and sealed by ORegan, Philip, PE on the date indicated here. Printed copies of this document are not considered signed and sealed and the signature must be verified on any electronic copies.

Philip J. O'Regan PE No.58126
MiTek Inc. DBA MiTek USA FL Cert 6634
16023 Swingley Ridge Rd. Chesterfield, MO 63017
Date:

March 10,2026

<p>WARNING - Verify design parameters and READ NOTES ON THIS AND INCLUDED MITEK REFERENCE PAGE MII-7473 rev. 1/2/2023 BEFORE USE.</p> <p>Design valid for use only with MiTek® connectors. This design is based only upon parameters shown, and is for an individual building component, not a truss system. Before use, the building designer must verify the applicability of design parameters and properly incorporate this design into the overall building design. Bracing indicated is to prevent buckling of individual truss web and/or chord members only. Additional temporary and permanent bracing is always required for stability and to prevent collapse with possible personal injury and property damage. For general guidance regarding the fabrication, storage, delivery, erection and bracing of trusses and truss systems, see ANSI/TPI1 Quality Criteria and DSB-22 available from Truss Plate Institute (www.tpinst.org) and BCSI Building Component Safety Information available from the Structural Building Component Association (www.sbcsccomponents.com)</p>	 <p>16023 Swingley Ridge Rd. Chesterfield, MO 63017 314.434.1200 / MiTek-US.com</p>
--	--

Job 5240843	Truss T20	Truss Type Common	Qty 1	Ply 1	Job Reference (optional)	T40398708
----------------	--------------	----------------------	----------	----------	--------------------------	-----------

Builders FirstSource (Lake City,FL), Lake City, FL - 32055,

Run: 8.83 S Jan 22 2026 Print: 8.830 S Jan 22 2026 MiTek Industries, Inc. Mon Mar 09 14:41:46
ID:KRWTMmDEHmQc50iXQi0i5Kzrv4Y-RfC?PsB70Hq3NSgPqnL8w3ulTXbGKwRCDoi7J4zJC?f

Page: 1

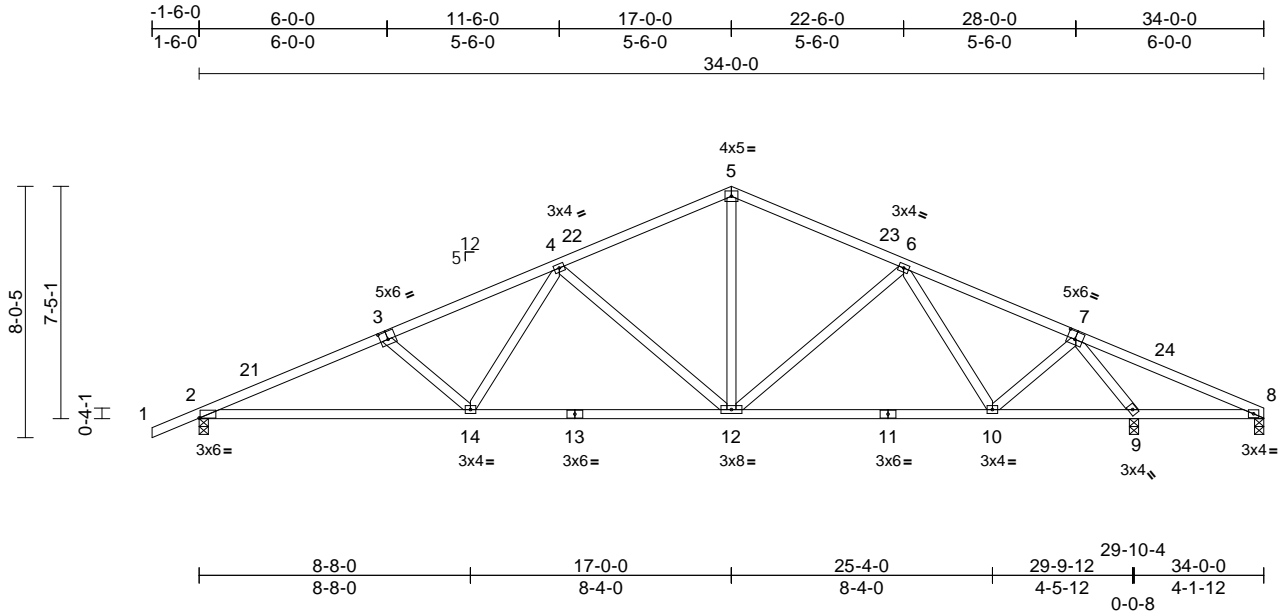

Scale = 1:73.6

Plate Offsets (X, Y): [2:0-0-6,Edge], [3:0-3-0,0-3-0], [7:0-3-0,0-3-0]

Loading	(psf)	Spacing	2-0-0	CSI	DEFL	in	(loc)	l/defl	L/d	PLATES	GRIP	
TCLL (roof)	20.0	Plate Grip DOL	1.25	TC	0.57	Vert(LL)	-0.13	14-20	>999	240	MT20	244/190
TCDL	10.0	Lumber DOL	1.25	BC	0.83	Vert(CT)	-0.30	14-20	>999	180		
BCLL	0.0*	Rep Stress Incr	YES	WB	0.71	Horz(CT)	0.07	9	n/a	n/a		
BCDL	10.0	Code	FBC2023/TPI2014	Matrix-MS							Weight: 170 lb	FT = 20%

LUMBER
TOP CHORD 2x4 SP No.2
BOT CHORD 2x4 SP No.2
WEBS 2x4 SP No.3

BRACING
TOP CHORD Structural wood sheathing directly applied or 3-4-5 oc purlins.
BOT CHORD Rigid ceiling directly applied or 5-4-10 oc bracing.

REACTIONS (size) 2=0-3-8, 8=0-3-8, 9=0-3-8
Max Horiz 2=139 (LC 12)
Max Uplift 2=-327 (LC 12), 8=-251 (LC 25), 9=-394 (LC 13)
Max Grav 2=1233 (LC 1), 8=78 (LC 12), 9=1826 (LC 1)

FORCES (lb) - Maximum Compression/Maximum Tension
TOP CHORD 1-2=0/35, 2-4=-2370/597, 4-5=-1289/327, 5-6=-1289/344, 6-8=-1027/1099
BOT CHORD 2-14=-610/2154, 12-14=-403/1640, 10-12=-175/1138, 9-10=-81/343, 8-9=-949/240
WEBS 4-14=-111/526, 3-14=-362/206, 4-12=-691/299, 5-12=-142/634, 6-12=-144/158, 6-10=-496/154, 7-10=-124/794, 7-9=-2084/467

- Building Designer / Project engineer responsible for verifying applied roof live load shown covers rain loading requirements specific to the use of this truss component.
 - This truss has been designed for a 10.0 psf bottom chord live load nonconcurrent with any other live loads.
 - * This truss has been designed for a live load of 20.0psf on the bottom chord in all areas where a rectangle 3-06-00 tall by 2-00-00 wide will fit between the bottom chord and any other members.
 - Provide mechanical connection (by others) of truss to bearing plate capable of withstanding 251 lb uplift at joint 8, 394 lb uplift at joint 9 and 327 lb uplift at joint 2.
- LOAD CASE(S)** Standard

- NOTES**
- Unbalanced roof live loads have been considered for this design.
 - Wind: ASCE 7-22; Vult=130mph (3-second gust) Vasd=101mph; TC DL=4.2psf; BCDL=3.0psf; h=18ft; Cat. II; Exp B; Enclosed; MWFRS (envelope) exterior (2) zone and C-C Zone3 -1-6-0 to 1-10-13, Zone1 1-10-13 to 17-0-0, Zone2 17-0-0 to 21-9-11, Zone1 21-9-11 to 34-0-0 zone; porch right exposed; C-C for members and forces & MWFRS for reactions shown; Lumber DOL=1.60 plate grip DOL=1.60

This item has been digitally signed and sealed by O'Regan, Philip, PE on the date indicated here. Printed copies of this document are not considered signed and sealed and the signature must be verified on any electronic copies.

Philip J. O'Regan PE No.58126
MiTek Inc. DBA MiTek USA FL Cert 6634
16023 Swingley Ridge Rd. Chesterfield, MO 63017
Date:

March 10, 2026

WARNING - Verify design parameters and READ NOTES ON THIS AND INCLUDED MITEK REFERENCE PAGE MII-7473 rev. 1/2/2023 BEFORE USE.

Design valid for use only with MiTek® connectors. This design is based only upon parameters shown, and is for an individual building component, not a truss system. Before use, the building designer must verify the applicability of design parameters and properly incorporate this design into the overall building design. Bracing indicated is to prevent buckling of individual truss web and/or chord members only. Additional temporary and permanent bracing is always required for stability and to prevent collapse with possible personal injury and property damage. For general guidance regarding the fabrication, storage, delivery, erection and bracing of trusses and truss systems, see **ANSI/TPI1 Quality Criteria and DSB-22** available from Truss Plate Institute (www.tpinst.org) and **BCSI Building Component Safety Information** available from the Structural Building Component Association (www.sbcsccomponents.com)

MiTek®

16023 Swingley Ridge Rd.
Chesterfield, MO 63017
314.434.1200 / MiTek-US.com

Job 5240843	Truss T21	Truss Type Hip Girder	Qty 1	Ply 1	Job Reference (optional)	T40398709
----------------	--------------	--------------------------	----------	----------	--------------------------	-----------

Builders FirstSource (Lake City,FL), Lake City, FL - 32055,

Run: 8.83 S Jan 22 2026 Print: 8.830 S Jan 22 2026 MiTek Industries, Inc. Mon Mar 09 14:41:47
ID:U3k4CS9zGqIU0vEa_XFIhznvCN-RfC?PsB70Hq3NSgPqnL8w3uITXbGKWrCDoi7J4zJC?f

Page: 1

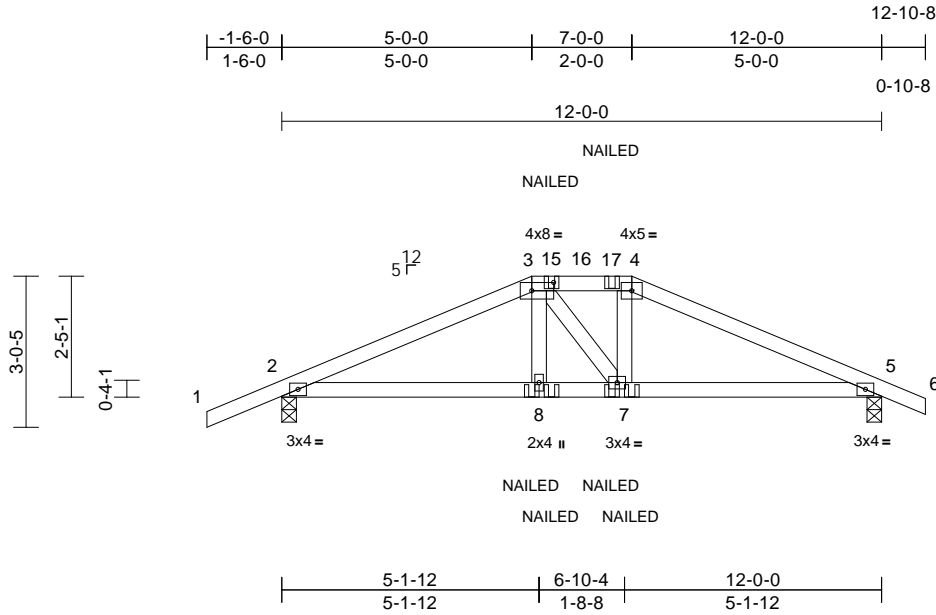

Scale = 1:46.1

Plate Offsets (X, Y): [3:0-5-4,0-2-0]

Loading	(psf)	Spacing	2-0-0	CSI	DEFL	in	(loc)	l/defl	L/d	PLATES	GRIP	
TCLL (roof)	20.0	Plate Grip DOL	1.25	TC	0.34	Vert(LL)	0.04	7-14	>999	240	MT20	244/190
TCDL	10.0	Lumber DOL	1.25	BC	0.45	Vert(CT)	-0.07	7-14	>999	180		
BCLL	0.0*	Rep Stress Incr	NO	WB	0.11	Horz(CT)	0.02	5	n/a	n/a		
BCDL	10.0	Code	FBC2023/TPI2014	Matrix-MS							Weight: 50 lb	FT = 20%

LUMBER

TOP CHORD 2x4 SP No.2
BOT CHORD 2x4 SP No.2
WEBS 2x4 SP No.3

BRACING

TOP CHORD Structural wood sheathing directly applied or 4-11-11 oc purlins.
BOT CHORD Rigid ceiling directly applied or 9-4-12 oc bracing.

REACTIONS (size) 2=0-3-8, 5=0-3-8

Max Horiz 2=50 (LC 12)
Max Uplift 2=-304 (LC 4), 5=-281 (LC 5)
Max Grav 2=732 (LC 1), 5=687 (LC 1)

FORCES (lb) - Maximum Compression/Maximum Tension

TOP CHORD 1-2=0/35, 2-3=-1179/462, 3-4=-1069/456, 4-5=-1179/466, 5-6=0/20
BOT CHORD 2-8=-379/1041, 7-8=-385/1057, 5-7=-383/1052
WEBS 3-8=-88/286, 3-7=-78/103, 4-7=-98/290

NOTES

- Unbalanced roof live loads have been considered for this design.
- Wind: ASCE 7-22; Vult=130mph (3-second gust) Vasd=101mph; TCDL=4.2psf; BCDL=3.0psf; h=18ft; Cat. II; Exp B; Enclosed; MWFRS (envelope) exterior (2) zone; porch left and right exposed; Lumber DOL=1.60 plate grip DOL=1.60
- Building Designer / Project engineer responsible for verifying applied roof live load shown covers rain loading requirements specific to the use of this truss component.
- Provide adequate drainage to prevent water ponding.
- This truss has been designed for a 10.0 psf bottom chord live load nonconcurrent with any other live loads.
- * This truss has been designed for a live load of 20.0psf on the bottom chord in all areas where a rectangle 3-06-00 tall by 2-00-00 wide will fit between the bottom chord and any other members.

- Provide mechanical connection (by others) of truss to bearing plate capable of withstanding 304 lb uplift at joint 2 and 281 lb uplift at joint 5.
 - "NAILED" indicates 3-10d (0.148"x3") or 3-12d (0.148"x3.25") toe-nails per NDS guidelines.
 - In the LOAD CASE(S) section, loads applied to the face of the truss are noted as front (F) or back (B).
- LOAD CASE(S)** Standard
- Dead + Roof Live (balanced): Lumber Increase=1.25, Plate Increase=1.25
Uniform Loads (lb/ft)
Vert: 1-3=-60, 3-4=-60, 4-6=-60, 9-12=-20
Concentrated Loads (lb)
Vert: 8=-156 (B), 7=-156 (B), 15=-2 (B), 17=-2 (B)

This item has been digitally signed and sealed by ORegan, Philip, PE on the date indicated here. Printed copies of this document are not considered signed and sealed and the signature must be verified on any electronic copies.

Philip J. O'Regan PE No.58126
MiTek Inc. DBA MiTek USA FL Cert 6634
16023 Swingley Ridge Rd. Chesterfield, MO 63017
Date:

March 10,2026

WARNING - Verify design parameters and READ NOTES ON THIS AND INCLUDED MITEK REFERENCE PAGE MII-7473 rev. 1/2/2023 BEFORE USE.

Design valid for use only with MiTek® connectors. This design is based only upon parameters shown, and is for an individual building component, not a truss system. Before use, the building designer must verify the applicability of design parameters and properly incorporate this design into the overall building design. Bracing indicated is to prevent buckling of individual truss web and/or chord members only. Additional temporary and permanent bracing is always required for stability and to prevent collapse with possible personal injury and property damage. For general guidance regarding the fabrication, storage, delivery, erection and bracing of trusses and truss systems, see **ANSI/TPI1 Quality Criteria and DSB-22** available from Truss Plate Institute (www.tpinst.org) and **BCSI Building Component Safety Information** available from the Structural Building Component Association (www.sbcsccomponents.com)

MiTek®

16023 Swingley Ridge Rd.
Chesterfield, MO 63017
314.434.1200 / MiTek-US.com

Symbols

PLATE LOCATION AND ORIENTATION

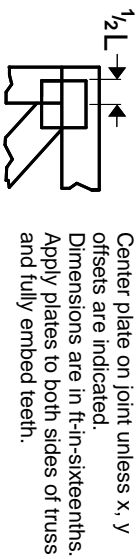

Center plate on joint unless x, y offsets are indicated. Dimensions are in ft-in-sixteenths. Apply plates to both sides of truss and fully embed teeth.

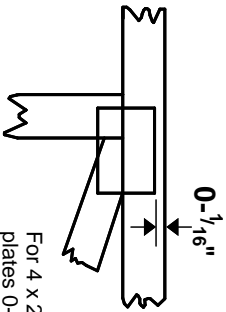

For 4 x 2 orientation, locate plates 0- 1/16\"/>



This symbol indicates the required direction of slots in connector plates.

* Plate location details available in MITtek software or upon request.

PLATE SIZE

4 X 4

The first dimension is the plate width measured perpendicular to slots. Second dimension is the length parallel to slots.

LATERAL BRACING LOCATION



Indicated by symbol shown and/or by text in the bracing section of the output. Use T or I bracing if indicated.

BEARING

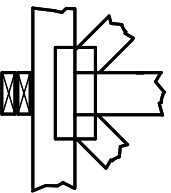

Indicates location where bearings (supports) occur. Icons vary but reaction section indicates joint number/letter where bearings occur. Min size shown is for crushing only.

Industry Standards:

ANSI/TP1: National Design Specification for Metal Plate Connected Wood Truss Construction.
DSB-22: Design Standard for Bracing.
BCSI: Building Component Safety Information, Guide to Good Practice for Handling, Installing, Restraining & Bracing of Metal Plate Connected Wood Trusses.

Numbering System

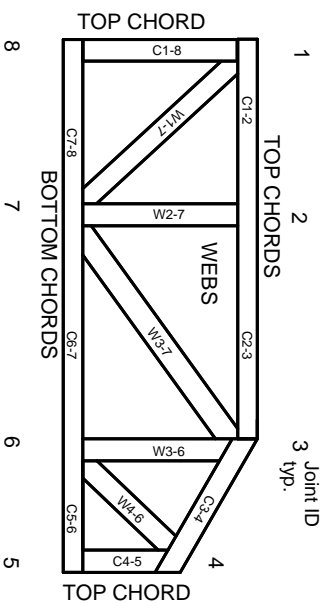

JOINTS ARE GENERALLY NUMBERED/LETTERED CLOCKWISE AROUND THE TRUSS STARTING AT THE JOINT FARTHEST TO THE LEFT.

CHORDS AND WEBS ARE IDENTIFIED BY END JOINT NUMBERS/LETTERS.

Product Code Approvals

ICC-ES Reports:

ESR-1-1988, ESR-2-362, ESR-2-685, ESR-3-282
ESR-4-722, ESL-1-388

Design General Notes

Trusses are designed for wind loads in the plane of the truss unless otherwise shown.

Lumber design values are in accordance with ANSI/TP1 section 6.3. These truss designs rely on Lumber values established by others.

© 2023 MITtek® All Rights Reserved

General Safety Notes

Failure to Follow Could Cause Property Damage or Personal Injury

1. Additional stability/bracing for truss system, e.g. diagonal or X-bracing, is always required. See BCSI.
2. Truss bracing must be designed by an engineer. For wide truss spacing, individual lateral braces themselves may require bracing, or alternative Tor I bracing should be considered.
3. Never exceed the design loading shown and never stack materials on inadequately braced trusses.
4. Provide copies of this truss design to the building designer, erection supervisor, property owner and all other interested parties.
5. Cut members to bear tightly against each other.
6. Place plates on each face of truss at each joint and embed fully. Knots and wane at joint locations are regulated by ANSI/TP1 1.
7. Design assumes trusses will be suitably protected from the environment in accord with ANSI/TP1 1.
8. Unless otherwise noted, moisture content of lumber shall not exceed 19% at time of fabrication.
9. Unless expressly noted, this design is not applicable for use with fire retardant, preservative treated, or green lumber.
10. Camber is a non-structural consideration and is the responsibility of truss fabricator. General practice is to camber for dead load deflection.
11. Plate type, size, orientation and location dimensions indicated are minimum plating requirements.
12. Lumber used shall be of the species and size, and in all respects, equal to or better than that specified.
13. Top chords must be sheathed or purlins provided at spacing indicated on design.
14. Bottom chords require lateral bracing at 10 ft. spacing, or less, if no ceiling is installed, unless otherwise noted.
15. Connections not shown are the responsibility of others.
16. Do not cut or alter truss member or plate without prior approval of an engineer.
17. Install and load vertically unless indicated otherwise.
18. Use of green or treated lumber may pose unacceptable environmental, health or performance risks. Consult with project engineer before use.
19. Review all portions of this design (front, back, words and pictures) before use. Reviewing pictures alone is not sufficient.
20. Design assumes manufacture in accordance with ANSI/TP1 1 Quality Criteria.
21. The design does not take into account any dynamic or other loads other than those expressly stated.

MITek®

MITtek Engineering Reference Sheet: Mill-7473 rev. 1/2/2023