

COLUMBIA COUNTY Property Appraiser

Parcel 12-3S-16-02069-000

Owners

J&J FLORIDA DEVELOPMENT, LLC
242 SE MIMOSA PL
LAKE CITY, FL 32025

GSA GIS

Pictometry



Parcel Summary

Location	282 NW FALLING CREEK RD
Use Code	0202: MOBILE HOME/M HOME
Tax District	3: COUNTY
Acreage	22.3100
Section	12
Township	3S
Range	16
Subdivision	DIST 3

Additional Site Addresses

284 NW FALLING CREEK RD

Legal Description

ALL THAT PORTION OF SEC 1,2,11 & 12 LYING E OF
US 41, N OF SR-131 & S OF CARTERS ACRES S/D.

841-1377, WD 1494-2051,2053

Working Values

	2026
Total Building	\$101,948
Total Extra Features	\$14,616
Total Market Land	\$232,024

//

	2026
Total Ag Land	\$0
Total Market	\$348,588
Total Assessed	\$348,588
Total Exempt	\$0
Total Taxable	\$348,588
SOH Diff	\$0

Value History

	2025	2024	2023	2022	2021	2020
Total Building	\$101,948	\$81,777	\$74,352	\$57,991	\$49,059	\$40,805
Total Extra Features	\$14,616	\$14,616	\$14,616	\$10,866	\$7,616	\$7,616
Total Market Land	\$232,024	\$232,024	\$232,024	\$232,024	\$99,183	\$99,102
Total Ag Land	\$0	\$0	\$0	\$0	\$0	\$0
Total Market	\$348,588	\$328,417	\$320,992	\$300,881	\$155,858	\$147,523
Total Assessed	\$348,588	\$328,417	\$188,588	\$171,444	\$155,858	\$147,523
Total Exempt	\$0	\$0	\$0	\$0	\$0	\$0
Total Taxable	\$348,588	\$328,417	\$188,588	\$171,444	\$155,858	\$147,523
SOH Diff	\$0	\$0	\$132,404	\$129,437	\$0	\$0

Document/Transfer/Sales History

Instrument / Official Record	Date	Q/U	Reason	Type	V/I	Sale Price	Ownership
<u>WD</u> 1494/2053	2023-07-07	<u>Q</u>	<u>01</u>	WARRANTY DEED	Improved	\$375,000	Grantor: HAFNER HALA J Grantee: J&J FLORIDA DEVELOPMENT, LLC
<u>WD</u> 1494/2051	2023-07-07	<u>U</u>	<u>11</u>	WARRANTY DEED	Improved	\$100	Grantor: CARIB INVESTMENTS INC Grantee: HAFNER HALA J
<u>WD</u> 0841/1377	1997-06-30	<u>U</u>	<u>35</u>	WARRANTY DEED	Improved	\$31,500	Grantor: HAFNER Grantee: CARIB INVESTMENTS INC

Buildings

Building # 1, Section # 1, 35121, COMMERCIAL BLDGS

Type	Models	Heated Sq Ft	Repl Cost New	YrBlt	Year Eff	Gross Area	Other % Dpr	Normal % Dpr	% Cond	Value
<u>0800</u>	<u>04</u>	6312	\$219,341	1975	1975	6,679	0.00%	60.00%	40.00%	\$87,736

Structural Elements

Type	Description	Code	Details
EW	Exterior Wall	08	WD OR PLY
EW	Exterior Wall	26	ALM SIDING
RS	Roof Structure	03	GABLE/HIP
RC	Roof Cover	01	MINIMUM
IW	Interior Wall	04	PLYWOOD
IF	Interior Flooring	14	CARPET
IF	Interior Flooring	08	SHT VINYL
CE	Ceiling	02	F.NOT SUS
AC	Air Conditioning	03	CENTRAL
HT	Heating Type	04	AIR DUCTED
FIX	Fixtures	6.00	
FR	Frame	02	WOOD FRAME
SH	Story Height	8.00	
RMS	RMS	24.00	
STR	Stories	1.	1.
COND	Condition Adjustment	03	03

Sub Areas

Type	Gross Area	Percent of Base	Adjusted Area
<u>BAS</u>	6,312	100%	6,312
<u>FOP</u>	60	30%	18
<u>FOP</u>	144	30%	43
<u>UOP</u>	163	20%	33

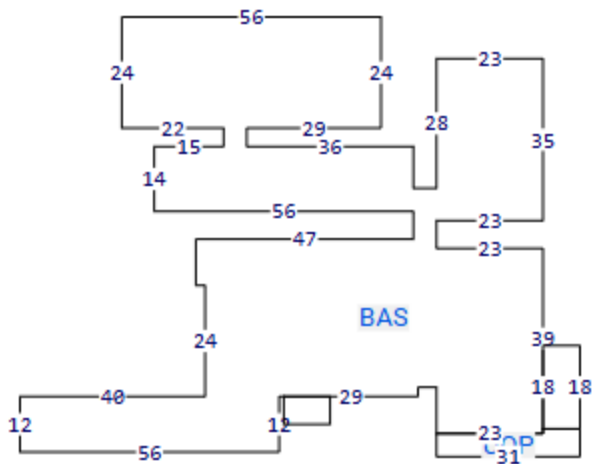

Building # 2, Section # 1, 5684, MOBILE HOME

Type	Models	Heated Sq Ft	Repl Cost New	YrBlt	Year Eff	Gross Area	Other % Dpr	Normal % Dpr	% Cond	Value
<u>0800</u>	<u>02</u>	672	\$35,529	1973	1973	672	0.00%	60.00%	40.00%	\$14,212

Structural Elements

Sub Areas

Type	Description	Code	Details
EW	Exterior Wall	26	ALM SIDING
RS	Roof Structure	03	GABLE/HIP
RC	Roof Cover	01	MINIMUM
IW	Interior Wall	04	PLYWOOD
IF	Interior Flooring	14	CARPET
IF	Interior Flooring	08	SHT VINYL
AC	Air Conditioning	01	NONE
HT	Heating Type	01	NONE
BDR	Bedrooms	3.00	
BTH	Bathrooms	2.00	
STR	Stories	1.	1.
AR	Architectual Type	01	CONV
COND	Condition Adjustment	03	03
KTCH	Kitchen Adjustment	01	01

Type	Gross Area	Percent of Base	Adjusted Area
<u>BAS</u>	672	100%	672

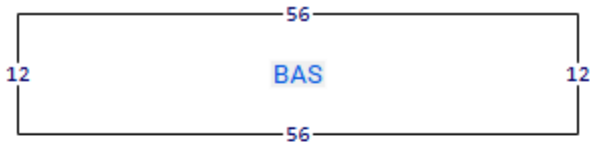

Extra Features

Code	Description	Length	Width	Units	Unit Price	<u>AYB</u>	% Good Condition	Final Value
0040	BARN,POLE	20	41	820.00	\$2.00	1993	100%	\$1,640
0040	BARN,POLE	24	83	1992.00	\$3.00	1993	100%	\$5,976
9945	Well/Sept			1.00	\$7,000.00		100%	\$7,000

Land Lines

Code	Description	Zone	Front	Depth	Units	Rate/Unit	Acreage	Total Adj	Value
0200	MBL HM	<u>CHI</u>	.00	.00	6.90	\$13,000.00/ <u>AC</u>	6.90	0.80	\$71,760

Code	Description	Zone	Front	Depth	Units	Rate/Unit	Acreage	Total Adj	Value
0000	VAC RES	A-1	.00	.00	5.13	\$13,000.00/AC	5.13	0.80	\$53,352
1000	VACANT COMMERCIAL	CHI	.00	.00	10.28	\$13,000.00/AC	10.28	0.80	\$106,912

Personal Property

Account	Secured/ Unsecured	Owner	Description
06411-000	Unsecured	HAFNER ENTERPRISES INC	B - BUSINESS

Permits

Date	Permit	Type	Status	Description
Sep 4, 2025	000053914	GENERATOR	PENDING	Right-of-Way Access/Driveway
Jun 16, 2025	000053356	GENERATOR	PENDING	Right-of-Way Access/Driveway

TRIM Notices

2025
2024
2023

Disclaimer

All parcel data on this page is for use by the Columbia County Assessor for assessment purposes only. The summary data on this page may not be a complete representation of the parcel or of the improvements thereon. Building information, including unit counts and number of permitted units, should be verified with the appropriate building and planning agencies. Zoning information should be verified with the appropriate planning agency. All parcels are reappraised each year. This is a true and accurate copy of the records of the Columbia County Assessor's Office as of April 02, 2026.