

UNINHABITED UTILITY SHED UP TO 12' WIDE x UP TO 24' LONG

PPTR, TR/TRD800

NOTES:

- BUILDING CODE:** FLORIDA BUILDING CODE, 8th EDITION (2023)
BUILDINGS ARE NOT FOR HIGH-VELOCITY HURRICANE ZONES (HVHZ)
- DESIGN LOADING:**
 WIND SPEED: $V_{ult} = 155$
 $V_{asd} = 120$
 EXPOSURE: C
 ROOF LIVE LOAD: 20 PSF
 ROOF DEAD LOAD: 10 PSF
 FLOOR LIVE LOAD: MIN. 50 PSF (SEE NOTE 5, DETAIL 1, SHEET 3)
 RISK CATEGORY: I
 COMPONENT AND CLADDING: ROOF: 29/-58 PSF (ZONE 1)
 WIND PRESSURE (psf) (ASD VALUES) 29/-77 PSF (ZONE 2)
 (BASED ON 10 SQ FT) 29/-101 PSF (ZONE 3)
 WALL: 31/-34 PSF (ZONE 4)
 31/-42 PSF (ZONE 5)

HEADER NAILING:
 HEADER TO STUD - 4-16d END NAIL DOUBLED HEADER
 - 16d @ 16" STAGGERED FACE NAIL

NAILING:
 REFER TO SHEET 2 FOR WALL AND ROOF SHEATHING NAILING.

MAX WALL HEIGHT FOR EACH SHED:
 PPTR - 7'-8 1/4" (92 1/4")
 TR/TRD800 - 7'-8 1/4" (92 1/4")

SHED SIZE CHART				
WIDTH	PITCH	SIDEWALL HEIGHT	OVERALL HEIGHT	MID-ROOF HEIGHT
6'	4/12	7'-8 1/4"	9'-5 3/4"	8'-10 13/16"
8'	4/12	7'-8 1/4"	9'-9 5/8"	9'-0 3/4"
10'	4/12	7'-8 1/4"	10'-1 9/16"	9'-2 1 1/16"
12'	4/12	7'-8 1/4"	10'-5 1/2"	9'-4 5/8"
6'	5/12	7'-8 1/4"	9'-9"	9'-0 1/4"
8'	5/12	7'-8 1/4"	10'-2"	9'-2 3/4"
10'	5/12	7'-8 1/4"	10'-6 15/16"	9'-5 3/16"
12'	5/12	7'-8 1/4"	10'-11 15/16"	9'-7 1 1/16"

ROOF SHEATHING (7/16" OSB)			
WIDTH	LENGTH	FIELD NAILING	EDGE NAILING
6'	6'-24'	8d NAILS @ 6" O.C.	8d NAILS @ 4" O.C.
8'	8'-24'	8d NAILS @ 6" O.C.	8d NAILS @ 4" O.C.
10'	10'-24'	8d NAILS @ 6" O.C.	8d NAILS @ 4" O.C.
12'	12'-24'	8d NAILS @ 6" O.C.	8d NAILS @ 4" O.C.

NOTES:
 USE GALVANIZED 0.113"Øx2 3/8" RING SHANK NAILS OR 8d COMMON NAILS

3/8" SMARTSIDE NAILING REQUIREMENTS 7/16" OSB NAILING REQUIREMENTS			
SIDEWALL NAILING (MIN. 2'-6" RETURN EACH END)			
WIDTH	LENGTH	FIELD NAILING	EDGE NAILING
6'	6'-24'	8d NAILS @ 6" O.C.	8d NAILS @ 3" O.C.
8'	8'-24'	8d NAILS @ 6" O.C.	8d NAILS @ 3" O.C.
10'	10'-24'	8d NAILS @ 6" O.C.	8d NAILS @ 3" O.C.
12'	12'-24'	8d NAILS @ 6" O.C.	8d NAILS @ 3" O.C.

3/8" SMARTSIDE NAILING REQUIREMENTS 7/16" OSB NAILING REQUIREMENTS			
END WALL NAILING (MIN. 2'-6" RETURN EACH END)			
WIDTH	LENGTH	FIELD NAILING	EDGE NAILING
6'	6'-24'	8d NAILS @ 6" O.C.	8d NAILS @ 3" O.C.
8'	8'-24'	8d NAILS @ 6" O.C.	8d NAILS @ 3" O.C.
10'	10'-24'	8d NAILS @ 6" O.C.	8d NAILS @ 3" O.C.
12'	12'-24'	8d NAILS @ 6" O.C.	8d NAILS @ 3" O.C.

SIDING TABLE NOTES:

- NAILING IS FOR 3/8" SMARTSIDE PANEL OR 3/8" SMARTSIDE WITH FOIL BACKER.
- MINIMUM 2'-6" RETURN FROM EACH END OF EACH WALL.**
- NO SINGLE OPENING GREATER THAN 8'-0"
- * 6' WIDE X 6'-9' LENGTH BUILDINGS ARE BASED ON 3-SIDED DIAPHRAGM. THE END WALL OPPOSITE OF THE OPENING MUST BE FULLY SHEATHED, IN THE 3-SIDED DIAPHRAGM CASES (NO OPENINGS) AND NAILED AS SPECIFIED. THE END WALL WITH THE OPENING DOES NOT HAVE A MIN. RETURN WALL ON EACH SIDE OF THE OPENING.
- USE COMMON OR GALVANIZED BOX NAILS WITH A MINIMUM LENGTH OF 2 1/2".

FL PRODUCT APPROVALS			
PRODUCT TYPE	MANUFACTURER	MODEL	FL PRODUCT #
SIDING (PANEL)	LP BUILDING SOLUTIONS	SIDING	FL9190.3
SIDING (LAP)	JAMES HARDIE BUILDING PRODUCTS, INC	LAP	FL10477.1
SIDING (CEMENT)	JAMES HARDIE BUILDING PRODUCTS, INC	CEMENT STUCCO	FL13223.2
IMPACT SLIDING WINDOW	ECO IMPACT SLIDER	IMPACT SLIDER	NOA 20-1119.09
SLIDING WINDOW	TAFCO CORP.	SLIDER	FL20743.1
TUFF SHED DOUBLE DOOR	TUFF SHED, INC.	SHED DOOR	FL22202.1
TUFF SHED DOUBLE DOOR (HVHZ)	TUFF SHED, INC.	SHED DOOR	FL22202.2
TUFF SHED SINGLE DOOR	TUFF SHED, INC.	SHED DOOR	FL22202.3
TUFF SHED SINGLE DOOR (HVHZ)	TUFF SHED, INC.	SHED DOOR	FL22202.4
STEEL DOOR INSWING	JELD-WEN	6 PANEL/3068	FL11136.1
STEEL DOOR OUTSWING	JELD-WEN	6 PANEL/3068	FL11136.2
FULL LITE DOOR	JELD-WEN	EXTERIOR DOOR	FL17454.1
9 LITE DOOR INSWING	JELD-WEN	EXTERIOR DOOR	FL12509.2
9 LITE DOOR OUTSWING	JELD-WEN	EXTERIOR DOOR	FL12509.4
FLOOD VENTS	FLOOD FLAPS	VENT	FL17381
RIDGE VENTS	GAF COBRA RIDGE RUNNER	RIDGE VENT	NOA 22-0726.06
RIDGE VENTS	GAF COBRA RIDGE VENT3	RIDGE VENT	FL6267.1
IMPACT RESISTANT OVERHEAD GARAGE DOOR	OVERHEAD GARAGE CORP.	GARAGE DOOR	FL14170.6
ROOF UNDERLAYMENT (HVHZ)	GAF	FELTBUSTER	FL10626.1
ROOF UNDERLAYMENT (NON-HVHZ)	GAF	FELTBUSTER	FL10626.2
ASPHALT SHINGLES (HVHZ)	GAF	SHINGLES	FL10124.1
ASPHALT SHINGLES (NON-HVHZ)	GAF	SHINGLES	FL10124.2

- BUILDING SIZES BELOW REQUIRE SHEATHING ON BOTH SIDES OF WALL WITH OPENING (7/16" OSB ON INSIDE OF WALL):
 6'X20'-24' WITH NO OPENINGS ON END WALL WITH 6' OF SHEAR
 8'X24' WITH NO OPENINGS ON END WALL WITH 8' OF SHEAR
 8'X18'-24' WITH 2' OF OPENING ON END WALL WITH 6' OF SHEAR
 8'X16'-22' WITH 3' OF OPENING ON END WALL WITH 5' OF SHEAR
 10'X24' WITH 2' OF OPENING ON END WALL WITH 8' OF SHEAR
 10'X20'-24' WITH 3' OF OPENING ON END WALL WITH 7' OF SHEAR
 10'X18'-24' WITH 4' OF OPENING ON END WALL WITH 6' OF SHEAR
 10'X16'-24' WITH 5' OF OPENING ON END WALL WITH 5' OF SHEAR
 12'X22'-24' WITH 4' OF OPENING ON END WALL WITH 8' OF SHEAR
 12'X20'-24' WITH 5' OF OPENING ON END WALL WITH 7' OF SHEAR
 12'X18'-24' WITH 6' OF OPENING ON END WALL WITH 6' OF SHEAR
 12'X14'-24' WITH 7' OF OPENING ON END WALL WITH 5' OF SHEAR
- NO OPENINGS ARE ALLOWED ON THE END WALLS OF 6' WIDE BUILDINGS LONGER THAN 9'.

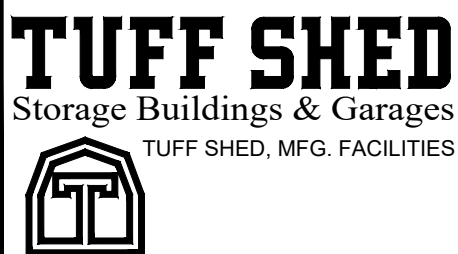

Order #: _____
 Customer: _____
 Site Address: _____
 Building Size: WIDTH - LENGTH - HEIGHT - SQ. FT. AREA

P.O. # _____
 Drawn By: TB
 Date: 12/5/23
 Checked By: _____
 Date: _____
 Scale: N.T.S.

THESE DRAWINGS AND THE DESIGN ARE THE PROPERTY OF TUFF SHED, INC. THESE DRAWINGS ARE FOR A BUILDING TO BE SUPPLIED AND BUILT BY TUFF SHED. ANY OTHER USE IS FORBIDDEN BY BOTH TUFF SHED AND THE ENGINEER OF RECORD.

TUFF SHED, INC.
 ENGINEERING DEPARTMENT

RICHARD J. WILLS, P.E.
 RWILLS@TUFFSHED.COM
 1777 S. HARRISON STREET
 DENVER, COLORADO 80210
 (303) 753-8833

TITLE

GENERAL NOTES

FBC, 8th EDITION (2023)

155C

DRAWING NO.

FL-PPTR-TR800-01

REV. LEVEL 01

SHEET 1

PAGE 1 OF 4

This item has been digitally signed and sealed by Richard Wills, PE, on the date adjacent to the seal.
 Printed copies of this document are not considered signed and sealed and the signature must be verified on any electronic copies.

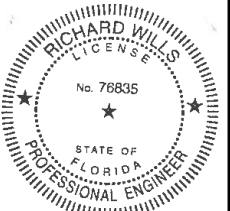

OVERHANG OPTIONS

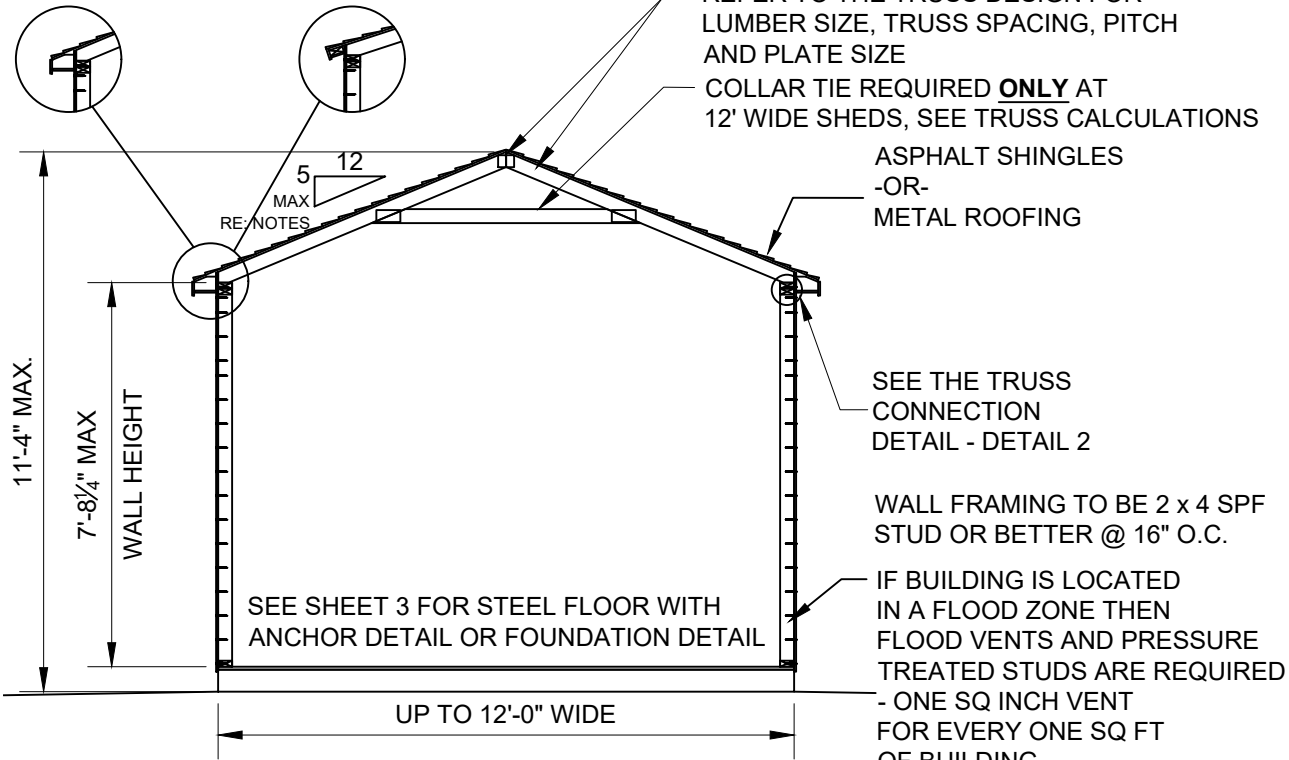

1 BUILDING SECTION
SCALE: N.T.S.

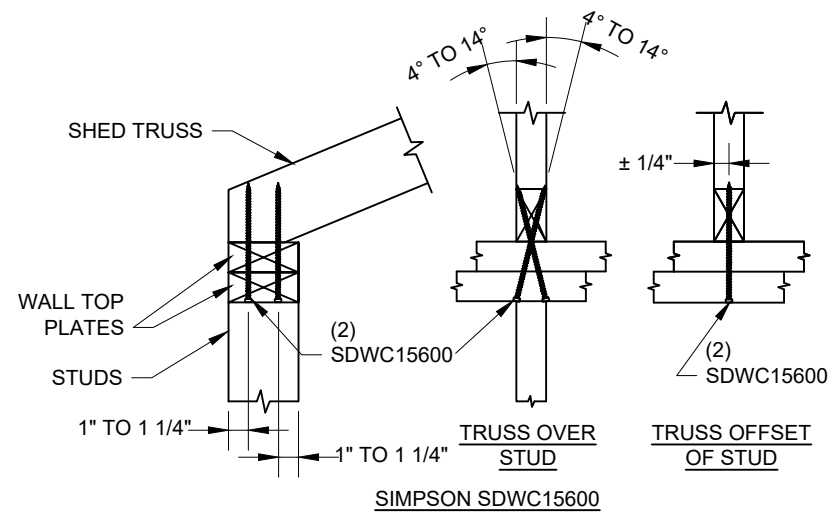

2 TRUSS TO WALL CONNECTION DETAIL
SCALE: N.T.S.

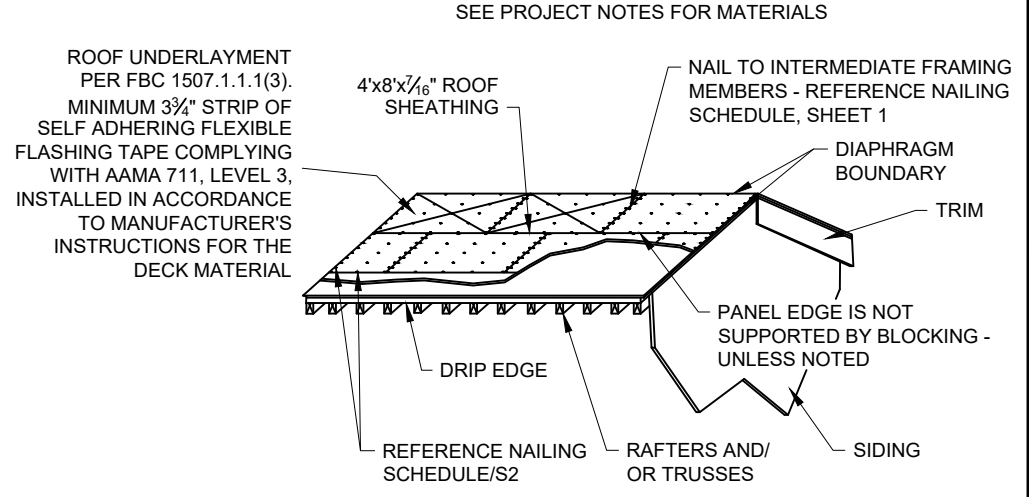

3 ROOF SHEATHING AND UNDERLAYMENT DETAIL
SCALE: N.T.S.

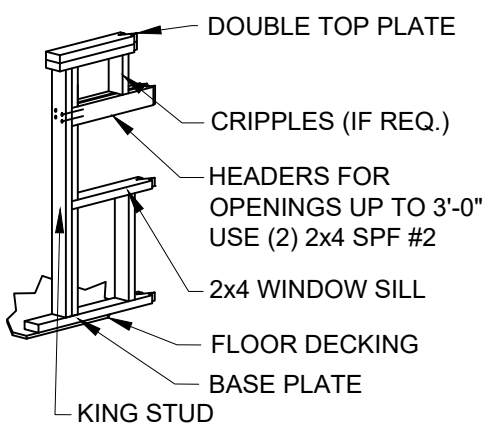

4A WINDOW HEADER DETAIL FOR SIDE WALLS
SCALE: N.T.S.

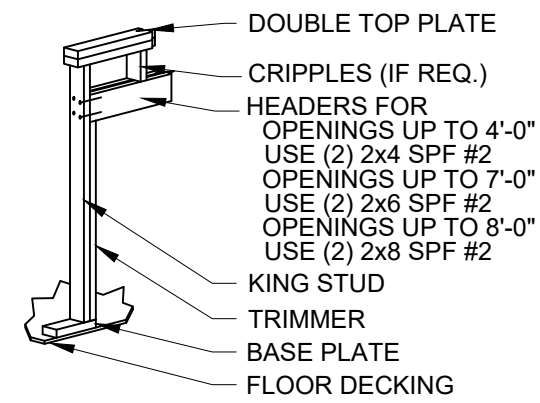

4B DOOR HEADER DETAIL FOR SIDE WALLS
SCALE: N.T.S.

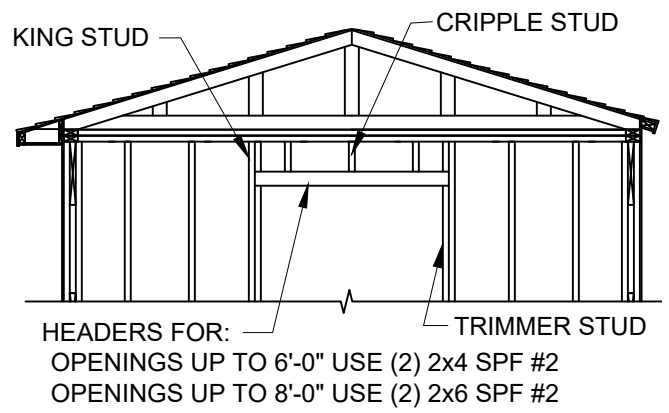

5 HEADER DETAIL FOR END WALLS
SCALE: N.T.S.

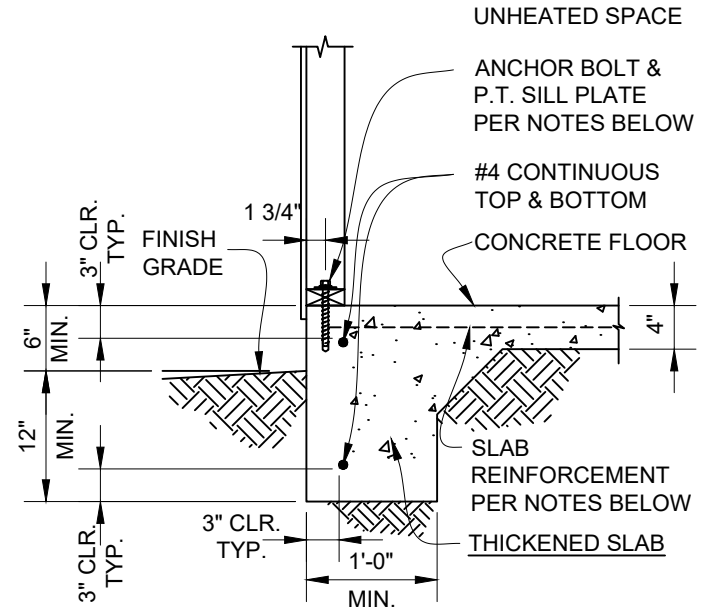

6 OPTIONAL CONCRETE FOUNDATION DETAIL
SCALE: N.T.S.

CONTINUOUS FOOTING NOTES

- TOP OF SLAB TO BE 6" MIN. ABOVE GRADE. SLAB REINFORCEMENT SHALL BE WWF 6X6 W1.4xW1.4. LOCATE AT MID-DEPTH OF SLAB.
 - OR-
 - SLAB REINFORCEMENT SHALL BE FIBERMESH 150 OR BLENDED FIBERMESH150. FIBERMESH SHOULD BE DISPERSED UNIFORMLY THROUGH CONCRETE W/ MIN. 1 POUND PER CUBIC YARD OF CONCRETE. ALL FOOTING FORMS SHALL BE INSPECTED FOR SIZE AND REINFORCING BEFORE POURING CONCRETE.
- FOOTINGS SHALL BEAR ON UNDISTURBED NATURAL, COMPETENT SOIL, OR PROPERLY COMPACTED STRUCTURAL FILL. ALLOWABLE SOIL BEARING PRESSURE IS 1000 PSF AT 12" BELOW GRADE.
- CONCRETE: MINIMUM 28 DAY COMPRESSIVE STRENGTH, $f_c = 2500$ PSI.
- REINFORCING STEEL: A615, GRADE 40 OR GRADE 60. ALL REINFORCING STEEL SHOWN TO BE CONTINUOUS MAY BE LAPPED A MINIMUM OF 38 BAR DIAMETERS OR 24" MINIMUM, WHICHEVER IS LARGER.
- SEISMIC DESIGN CATEGORY: A
 - A. ATTACH PRESSURE TREATED SOLE PLATE TO THE FOOTING USING 1/2" X 8" LONG SIMPSON TITEN HD ANCHOR WITH WASHERS.
 - B. EXPANSION BOLTS SHALL BE EMBEDDED AT LEAST 5" INTO THE CONCRETE AND SHALL BE SPACED NOT MORE THAN 6' OC.
 - C. THERE SHALL BE A MINIMUM OF 2 BOLTS PER SOLE PLATE PIECE WITH 1 BOLT LOCATED NOT MORE THAN 12" NOR LESS THAN 7 BOLT DIAMETERS FROM EACH END OF EACH PIECE. A MINIMUM OF 4 BOLTS ARE REQUIRED PER SIDE OF THE BUILDING.

NOTE: FOR BUILDINGS 18' AND LONGER OR ANY BUILDING DESIGNED AS A 3-SIDED DIAPHRAGM, ADD SIMPSON SSTB16 ANCHORS AND HDU2 HOLD DOWNS AT EACH CORNER OF THE END WALLS. FOLLOW MANUFACTURER'S INSTALLATION INSTRUCTIONS.

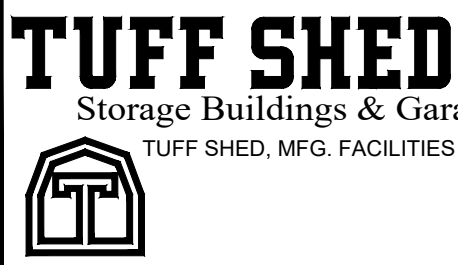

Order #. _____
 Customer: _____
 Site Address: _____
 Building Size: WIDTH - LENGTH - HEIGHT - SQ. FT. AREA _____

P.O. # _____
 Drawn By: TB
 Date: 12/5/23
 Checked By: _____
 Date: _____
 Scale: N.T.S.

THESE DRAWINGS AND THE DESIGN ARE THE PROPERTY OF TUFF SHED, INC. THESE DRAWINGS ARE FOR A BUILDING TO BE SUPPLIED AND BUILT BY TUFF SHED. ANY OTHER USE IS FORBIDDEN BY BOTH TUFF SHED AND THE ENGINEER OF RECORD.

TUFF SHED, INC.
 ENGINEERING DEPARTMENT
 RICHARD J. WILLS, P.E.
 RWILLS@TUFFSHED.COM
 1777 S. HARRISON STREET
 DENVER, COLORADO 80210
 (303) 753-8833

TITLE
 BUILDING SECTIONS
 HEADER FRAMING DETAILS
 FBC, 8th EDITION (2023)
 155C

DRAWING NO.
 FL-PPTR-TR800-01
REV. LEVEL 01
SHEET 2
PAGE 2 OF 4

This item has been digitally signed and sealed by Richard Wills, PE, on the date adjacent to the seal.
 Printed copies of this document are not considered signed and sealed and the signature must be verified on any electronic copies.



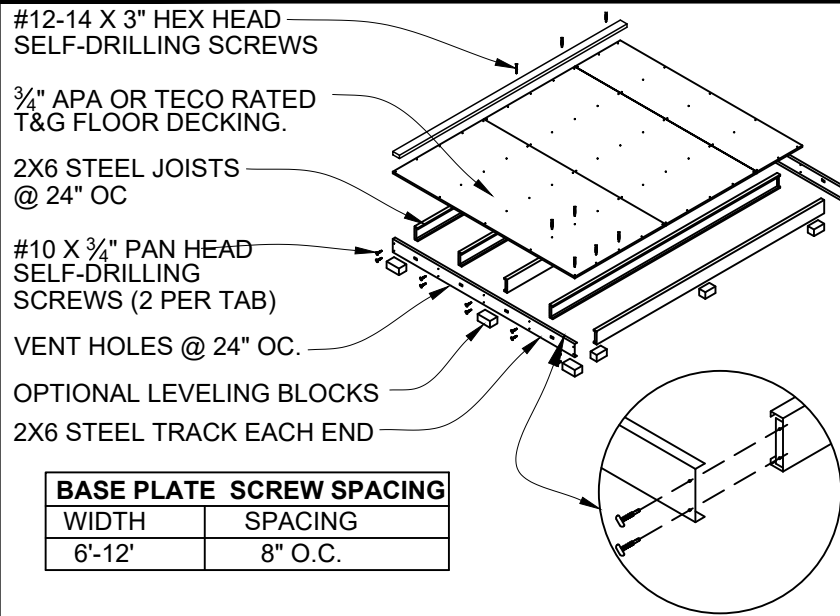

- STEEL SHED FOUNDATION:
600T125-054 - 16 GAUGE STEEL TRACKS G140 ZINC COATED
600S137-054 - 16 GAUGE STEEL JOISTS G140 ZINC COATED @ 24" O.C.
(SUPPLIER: ALLIED STUDCO (JOIST: 600S137-054 / TRACK: 600T125-054) ICC ER-4943P.
- 3/4" APA OR TECO RATED TONGUE AND GROOVE FLOOR DECKING. 24" MAX PANEL SPAN. STAGGER PANEL LAYOUT.
- FASTEN FLOOR DECKING TO JOIST & TRACKS USING #8 x 1 5/8" ZINC PLATED SCREWS @ 12" O.C. NO BLOCKING REQUIRED. ALL EDGES SHALL LIE ON FLOOR JOISTS. STAGGER PANEL LAYOUT PER APA CONDITION 1.
- FASTEN SOLE PLATE THROUGH FLOOR DECKING INTO JOISTS OR TRACKS WITH #12-14 X 3" GALVANIZED SELF-DRILLING SCREWS. REFERENCE SPACING CHART.
- ALLOWABLE FLOOR LIVE LOAD: 75 PSF FOR STEEL JOISTS CONTINUOUSLY SUPPORTED. 50 PSF FOR JOISTS ON BLOCKS AS SHOWN.
- USE OPTIONAL CONCRETE BLOCKS AS REQUIRED TO LEVEL BUILDING:
SUGGESTED SIZES: 2" x 8" x 16", 4" x 8" x 16", OR 8" x 8" x 16".
BLOCKS UNDER JOISTS SPACED @ 8'-0" O.C. MAXIMUM.
BLOCKS UNDER TRACK SPACED @ 4'-0" O.C. MAXIMUM.

BASE PLATE SCREW SPACING	
WIDTH	SPACING
6'-12'	8" O.C.

1 OPTIONAL STEEL SHED BASE DETAIL

SCALE: N.T.S.

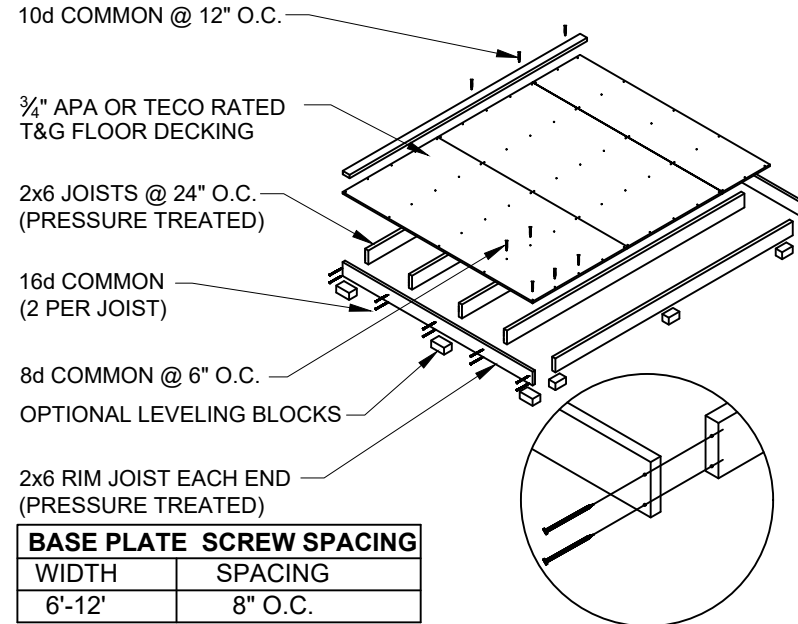

BASE PLATE SCREW SPACING	
WIDTH	SPACING
6'-12'	8" O.C.

2 OPTIONAL WOOD SHED BASE DETAIL

SCALE: N.T.S.

- WOOD SHED FOUNDATION:
2x6 #2 PRESSURE TREATED SPRUCE-PINE-FIR RIM JOISTS
2x6 #2 PRESSURE TREATED SPF JOISTS @ 24" O.C.
- 3/4" APA OR TECO RATED TONGUE AND GROOVE FLOOR DECKING. 24" MAX PANEL SPAN. NO BLOCKING REQUIRED. ALL EDGES SHALL LIE ON FLOOR JOISTS. STAGGER PANEL LAYOUT PER APA CONDITION 1. NAIL PLYWOOD TO JOISTS AND RIM JOISTS:
BORDER: 8d COMMON SPACED @ 6" O.C.
EDGE: 8d COMMON SPACED @ 6" O.C.
FIELD: 8d COMMON SPACED @ 12" O.C.
- FASTEN SOLE PLATE THROUGH FLOOR DECKING INTO JOISTS OR RIM JOISTS WITH 10d COMMON SPACED @ 12" O.C.
- ALLOWABLE FLOOR LIVE LOAD: 40 PSF
- USE OPTIONAL CONCRETE BLOCKS AS REQUIRED TO LEVEL BUILDING:
SUGGESTED SIZES: 2" x 8" x 16", 4" x 8" x 16", OR 8" x 8" x 16".
BLOCKS UNDER JOISTS SPACED @ 8'-0" O.C. MAXIMUM.
BLOCKS UNDER RIM JOISTS SPACED @ 4'-0" O.C. MAXIMUM.

TITEN HD ANCHOR BOLTS (INTO CONCRETE) RE: DETAIL 3, SHEET 3

WIDTH	LENGTH	QTY
6'	6'-14'	4
6'	16'-22'	6
6'	24'	8
8'	8'-10'	4
8'	12'-16'	6
8'	18'-22'	8
8'	24'	10
10'	10'-14'	6
10'	16'-18'	8
10'	20'-22'	10
10'	24'	12
12'	12'-14'	8
12'	16'-18'	10
12'	20'-24'	14

- NOTES:
- ANCHORS TO BE SIMPSON TITEN HD ANCHORS. ANCHORS MAY BE GALVANIZED OR STAINLESS STEEL.
 - PROVIDE (1) ANCHOR AT EA. CORNER OF THE BUILDING. THE REMAINING ANCHORS EQUALLY SPACED ALONG THE LENGTH OF THE BUILDING. (1/2 THE REMAINING ANCHORS ON EA. LENGTH SIDE EQUALLY SPACED).

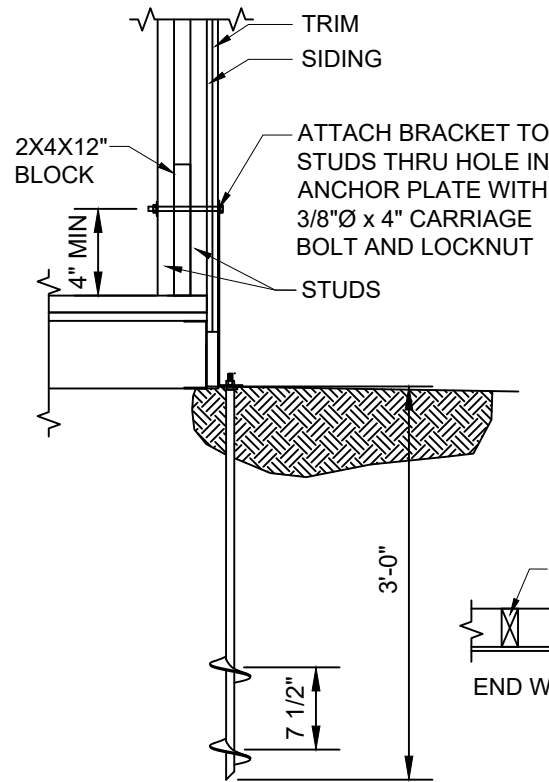

AUGER ANCHOR COMPONENTS BY OLIVER TECHNOLOGIES

- PART NUMBERS:
OT3644BGMP - 5/8" X 36" (36" IMBED) GALVANIZED AUGER REPORT NO. RAD-3060
OT17SWB - SIDEWALL BRACKET FOR USE WITH THRU BOLTS REPORT NO. LO-FJ90129-A
-OR-
OT24SWB - SIDEWALL BRACKET FOR USE WITH THRU BOLTS REPORT NO. LO-FJ90129-B
- WORKING LOAD FOR ANCHOR SYSTEM IS 3,150 LBS WITH THE MAXIMUM LOAD OF 4,725 LBS

AUGER ANCHORS		
WIDTH	LENGTH	# OF ANCHORS
6'	6'-24'	4 ANCHORS
8'	8'-18'	4 ANCHORS
8'	20'-24'	6 ANCHORS
10'	10'-14'	4 ANCHORS
10'	16'-22'	6 ANCHORS
10'	24'	8 ANCHORS
12'	12'-18'	6 ANCHORS
12'	20'-24'	8 ANCHORS

4-ANCHORS PROVIDE (1) AT EACH CORNER OF THE BUILDING.
6-ANCHORS PROVIDE (1) AT EACH CORNER OF THE BUILDING AND (1) AT THE CENTER OF EACH SIDE WALL.
8-ANCHORS PROVIDE (1) AT EACH CORNER OF THE BUILDING AND (1) AT THE CENTER OF EACH WALL.

3 OPTIONAL AUGER ANCHOR DETAIL

SCALE: N.T.S.

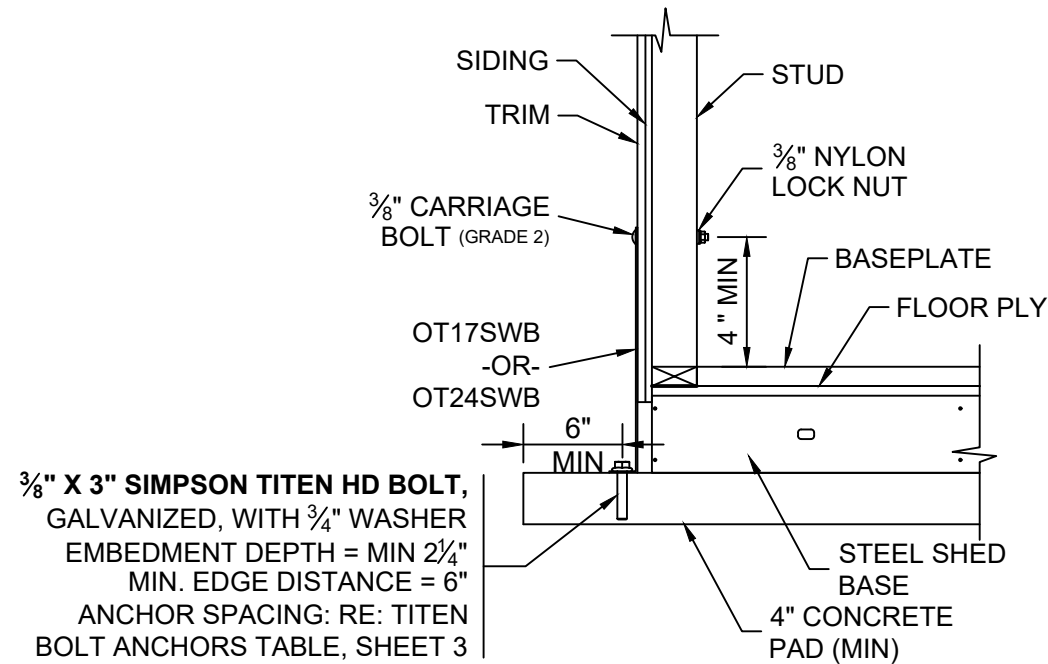

3/8" X 3" SIMPSON TITEN HD BOLT, GALVANIZED, WITH 3/4" WASHER
EMBEDMENT DEPTH = MIN 2 1/4"
MIN. EDGE DISTANCE = 6"
ANCHOR SPACING: RE: TITEN BOLT ANCHORS TABLE, SHEET 3

4 OPTIONAL SIDEWALL BRACKET DETAIL

SCALE: N.T.S.

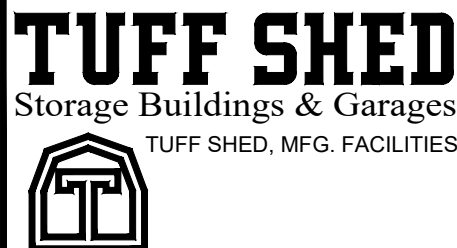

Order #: _____
Customer: _____
Site Address: _____
Building Size: WIDTH - LENGTH - HEIGHT - SQ. FT. AREA _____

P.O. # _____
Drawn By: TB
Date: 12/5/23
Checked By: _____
Date: _____
Scale: N.T.S.

THESE DRAWINGS AND THE DESIGN ARE THE PROPERTY OF TUFF SHED, INC. THESE DRAWINGS ARE FOR A BUILDING TO BE SUPPLIED AND BUILT BY TUFF SHED. ANY OTHER USE IS FORBIDDEN BY BOTH TUFF SHED AND THE ENGINEER OF RECORD.

TUFF SHED, INC.
ENGINEERING DEPARTMENT

RICHARD J. WILLS, P.E.
RWILLS@TUFFSHED.COM
1777 S. HARRISON STREET
DENVER, COLORADO 80210
(303) 753-8833

TITLE
DETAILS
FBC, 8th EDITION (2023)
155C

DRAWING NO.
FL-PPTR-TR800-01
REV. LEVEL 01
SHEET 3
PAGE 3 OF 4

This item has been digitally signed and sealed by Richard Wills, PE, on the date adjacent to the seal.
Printed copies of this document are not considered signed and sealed and the signature must be verified on any electronic copies.

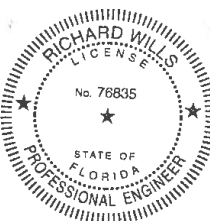

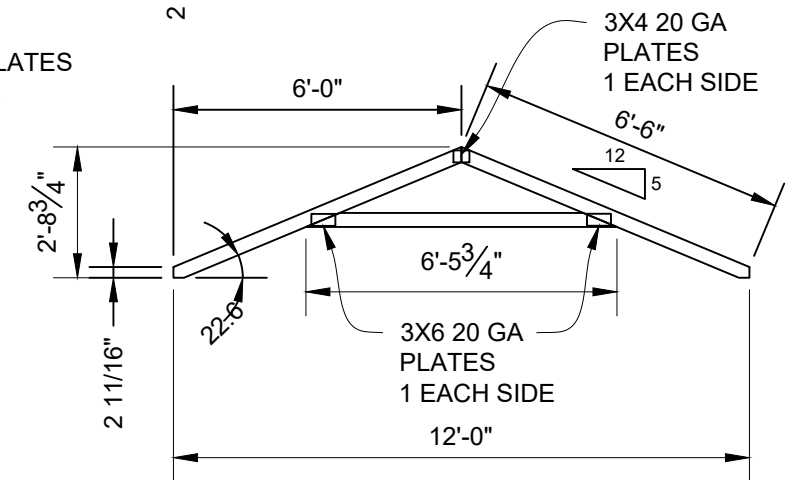
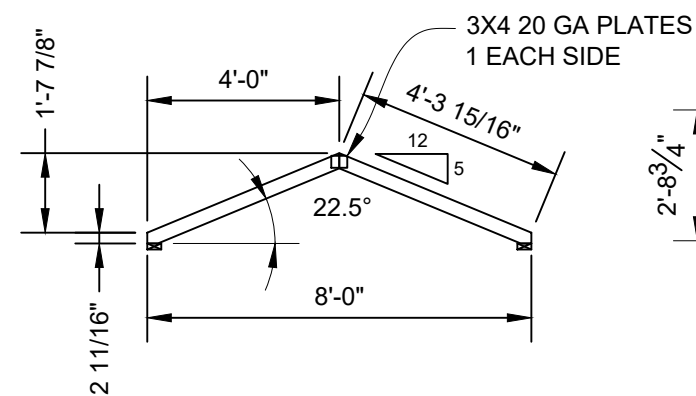
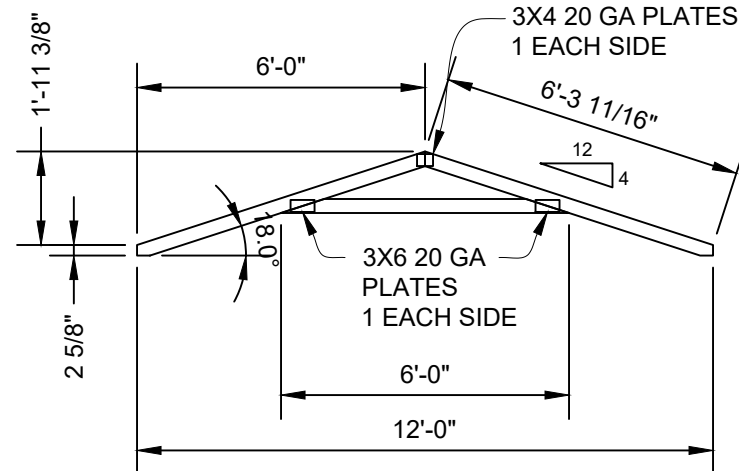
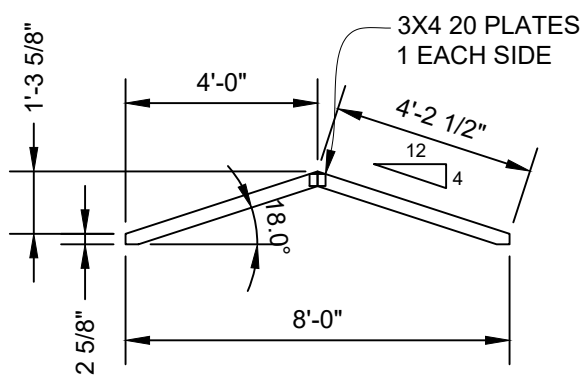
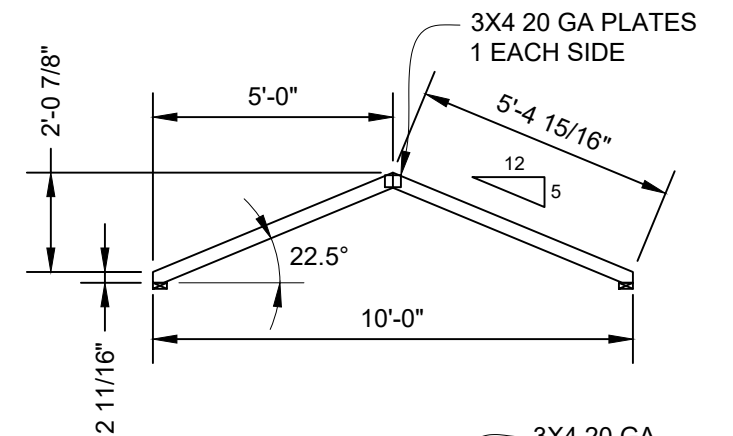
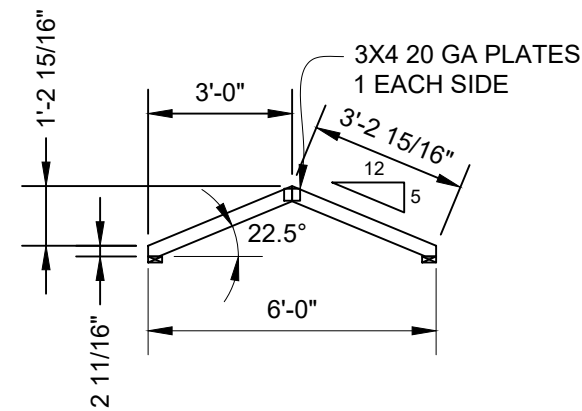
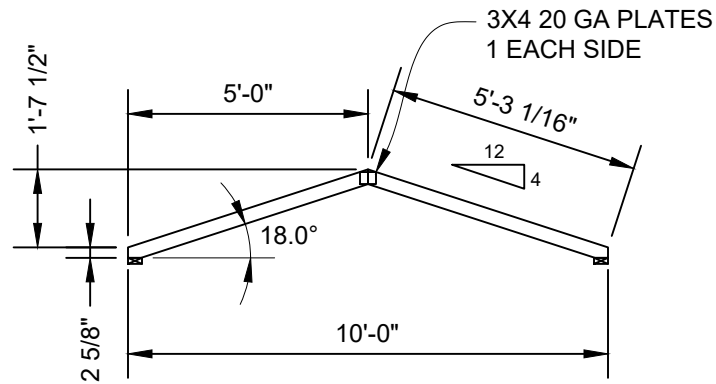
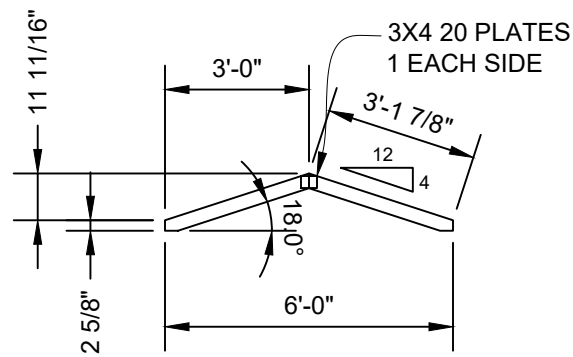

DESIGN LOADS:
 TOP CHORD LIVE LOAD = 20 PSF
 TOP CHORD DEAD LOAD = 10 PSF
 COLLAR TIE DEAD LOAD = 5 PSF

NOTES:
 FBC, 8th EDITION (2023)
 ANSI/TPI 1-2014
 TRUSSES TO BE SPACED @ 24" OC
 MATERIAL TO BE 2X4 SPRUCE PINE FIR GRADE #2
 OR BETTER
 PLATES ARE TO BE PRESSED IN THE WOOD PER
 TPI.

REP MEMBER INCREASE: YES
 LUMBER D.O.L.: 1.25

WIND:
 ASCE 7-22, 155 mph, Exposure C, D.O.L.=1.60

PLATES ARE MANUFACTURED BY EAGLE METAL
 PRODUCTS, ICC-ES #ESR-1082.

6' SPAN
 REACTIONS:
 MAX. VERTICAL: 180 LBS.
 MAX. UPLIFT: -160 LBS.

NOTE:
 TRUSS MAY BE USED ON BUILDING LENGTHS
 UP TO 12FT UNLESS CEILING JOIST OR OTHER
 TENSION TIE IS PROVIDED.

8' SPAN
 REACTIONS:
 MAX. VERTICAL: 240 LBS.
 MAX. UPLIFT: -195 LBS.

NOTE:
 TRUSS MAY BE USED ON BUILDING LENGTHS
 UP TO 14FT UNLESS CEILING JOIST OR OTHER
 TENSION TIE IS PROVIDED.

10' SPAN
 REACTIONS:
 MAX. VERTICAL: 300 LBS.
 MAX. UPLIFT: -250 LBS.

NOTE:
 TRUSS MAY BE USED ON BUILDING LENGTHS
 UP TO 16FT UNLESS CEILING JOIST OR OTHER
 TENSION TIE IS PROVIDED.

12' SPAN
 REACTIONS:
 MAX. VERTICAL: 405 LBS.
 MAX. UPLIFT: -290 LBS.

NOTE:
 TRUSS MAY BE USED ON BUILDING LENGTHS
 UP TO 20FT UNLESS CEILING JOIST OR OTHER
 TENSION TIE IS PROVIDED.

MAXIMUM DEFLECTION (12 FT. SPAN)
 VERT LL: 0.06 in.
 VERT TL: 0.08 in.

ALL PERSONS FABRICATING, HANDLING, ERECTING OR INSTALLING THIS TRUSS ARE TO DO SO IN
 ACCORDANCE TO THE RECOMMENDATIONS OF THE LATEST VERSION OF THE BCSI.



Order #: _____
 Customer: _____
 Site Address: _____
 Building Size: WIDTH - LENGTH - HEIGHT - SQ. FT. AREA _____

P.O. # _____
 Drawn By: TB
 Date: 12/5/23
 Checked By: _____
 Date: _____
 Scale: N.T.S.

THESE DRAWINGS AND THE
 DESIGN ARE THE PROPERTY
 OF TUFF SHED, INC. THESE
 DRAWINGS ARE FOR A
 BUILDING TO BE SUPPLIED
 AND BUILT BY TUFF SHED.
 ANY OTHER USE IS
 FORBIDDEN BY BOTH TUFF
 SHED AND THE ENGINEER OF
 RECORD.

TUFF SHED, INC.
 ENGINEERING DEPARTMENT
 RICHARD J. WILLS, P.E.
 RWILLS@TUFFSHED.COM
 1777 S. HARRISON STREET
 DENVER, COLORADO 80210
 (303) 753-8833

TITLE
 TRUSS DETAILS
 FBC, 8th EDITION (2023)
 155C

DRAWING NO.
 FL-PPTR-TR800-01
 REV. LEVEL 01
 SHEET 4
 PAGE 4 OF 4

This item has been digitally signed and sealed by
 Richard Wills, PE, on the date adjacent to the seal.
 Printed copies of this document are not considered
 signed and sealed and the signature must be
 verified on any electronic copies.

