

DESIGN CRITERIA:

APPLICABLE CODES, REGULATIONS & STANDARDS:

1. THE 2023 FLORIDA BUILDING CODE 8TH EDITION, SPECIFICALLY CHAPTER 16 STRUCTURAL DESIGN, CH. 20 ALUM. & CH. 23 WOOD.
2. AA ASM 35 & SPECIFICATIONS FOR ALUMINUM STRUCTURES, PART 1-A OF THE ALUMINUM DESIGN MANUAL PREPARED BY THE ALUMINUM ASSOCIATION, INC. WASHINGTON D.C. 2005 ED.
3. ASCE 7-22 & SE17
4. NDS NATIONAL DESIGN SPECIFICATION FOR WOOD.
5. ACI318 CONCRETE REFERENCE MANUAL.

WIND LOADS:

1. BUILDING OCCUPANCY CATEGORY, PARAGRAPH 1604.5 & TABLE 1604.5: RISK CATEGORY: I
2. BASIC WIND SPEED, TABLE 1609C, STATE OF FLORIDA DEBRIS REGION & BASIC WIND SPEED, PARAGRAPH 1609.3.1 & TABLE 1609.3.1 EQUIVALENT BASIC WIND SPEED: $\frac{110}{C}$ MPH EXPOSURE CATEGORY, PARAGRAPH 1609.4.3: $\frac{110}{C}$
3. WIND LOADS PER FBC TABLE 2002.4 (MWFRS) VULT = 110 MPH & EXPOSURE = C

FOR 20 X 20 X 0.013" MESH SCREEN
 HORIZONTAL PRESSURES ON WINDWARD SURFACES = $\frac{21 \text{ PSF}}{16 \text{ PSF}}$
 HORIZONTAL PRESSURES ON LEEWARD SURFACES = $\frac{16 \text{ PSF}}{7 \text{ PSF}}$
 VERTICAL PRESSURES ON SCREEN SURFACES = $\frac{7 \text{ PSF}}{21 \text{ PSF}}$
 VERTICAL PRESSURES ON SOLID SURFACES = $\frac{21 \text{ PSF}}{21 \text{ PSF}}$

FOR 18 X 14 X 0.013" MESH SCREEN, APPLIED FACTOR = $\frac{.88}{.6}$
 FOR ALLOWABLE STRESS DESIGN, APPLIED FACTOR = $\frac{.88}{.6}$

FOUNDATION DESIGN:

NO ADDITIONAL FOOTING OR FOUNDATION SYSTEM IS REQUIRED BY THE PROPOSED CONSTRUCTION IF A MINIMUM 4" CONCRETE SLAB IS PROVIDED IN SOUND CONDITION, FREE FROM STRUCTURAL CRACKING, SPALLING & OTHER DETERIORATION. EXISTING FOUNDATION/FOOTING UNDER CONCRETE SLAB MINIMUM 8"x8" w/ (1) #5 BAR TO BE VERIFIED BY CONTRACTOR. SEE TYPICAL FOOTING DETAILS FOR NEW FOOTING DESIGN MINIMUM REQUIREMENTS.

MISCELLANEOUS:

1. SCREENED ENCLOSURES CONTAINING SWIMMING POOLS SHALL COMPLY WITH THE APPLICABLE REQUIREMENTS OF FBC R4501.17 RESIDENTIAL SWIMMING BARRIER REQUIREMENTS.
2. ALUMINUM ADDITIONS ARE NOT TO BE INSTALLED ON A MANUFACTURED HOME, TRAILER HOME, OR PRE-FAB HOME. IF THE EXISTING STRUCTURE IS ONE OF THESE, A SEPARATE 4TH WALL SUPPORT SYSTEM IS SO TO BE ENGINEERED SO THAT NO ADDITIONAL LOADING IS PLACED ON THE MANUFACTURED HOME.
3. THE ENGINEERING ON THESE PLANS IS SITE SPECIFIC FOR (1) STRUCTURE ONLY AT THE PROVIDED ADDRESS(ES).

FASTENER SPECIFICATIONS:

1. FASTENERS ARE REQUIRED TO BE SAE GRADE 2 OR BETTER ZINC PLATED. (CONCRETE ANCHORS ARE TO BE 410 S.S. TAPCONS OR BETTER, INSTALLED TO MFG. SPECIFICATIONS)
2. WHERE WOOD DECK IS PRESENT USE 1/4" X 3-1/2" GALV. LAG SCREWS IN LIEU OF MASONRY ANCHORS. UNLESS OTHERWISE SPECIFIED.
3. FOR 1"x2" NON-STRUCTURAL MEMBERS ATTACHED TO HOST
 - a. FOR MASONRY/CONCRETE APPLICATION USE GALVANIZED 1/4" X 2-3/4" TAPCONS 6" FROM ENDS & 24" CENTER TO CENTER.
 - b. FOR WOOD APPLICATION USE # 14 X 2-3/4" WOOD SCREW AT 6" FROM ENDS & 24" CENTER TO CENTER.
 - c. FOR ALUMINUM APPLICATION USE #10 X 1-1/2" SMS OR TEK 6" FROM ENDS & 24" CENTER TO CENTER..
 - d. WHERE 1"x2" INSTALLED THROUGHOUT AN "OPEN VIEW" SPACING SHALL BE REDUCED TO 6" FROM ENDS & 18" C.C.

RESPONSIBILITIES:

1. ALL SITE WORK SHALL BE PERFORMED BY A LICENSED CONTRACTOR IN ACCORDANCE WITH APPLICABLE BUILDING CODES, LOCAL ORDANANCES, AND THE ENGINEER SHALL BE NOTIFIED OF ANY DISCREPANCIES.
2. FOR FASTENERS WHICH ARE NOT VISIBLE AFTER INSTALLATION, THE CONTRACTOR SHALL VERIFY AND ENSURE INSTALLATION HAS BEEN ACCOMPLISHED IN ACCORDANCE WITH MANUFACTURERS SPECIFICATIONS AND IN ACCORDANCE WITH THE ATTACHED DETAILS.
3. CONTRACTOR TO PROVIDE NOA'S & INSTALL ALL MATERIALS AS PER MANUFACTURER'S SPECIFICATIONS.
4. INTEGRITY OF EXISTING/ HOST STRUCTURE SHALL NOT BE COMPROMISED WITH THE ATTACHMENT OF THE PROPOSED STRUCTURE.
5. IT IS THE OWNERS RESPONSIBILITY TO MAINTAIN THE SCREENS & FASTENERS TO MANUFACTURING SPECIFICATIONS.
6. METAL WITHIN 5FT OF THE WATERS EDGE REQUIRE A CONTINUOUS BOND PER NEC NFPA 70: NATIONAL ELECTRIC CODE 680.43(D)(4): ALL METAL SURFACES THAT ARE WITHIN 1.5M (5FT) OF THE INSIDE WALLS OF THE SPA OR HOT TUB AND THAT ARE NOT SEPERATED FROM THE SPA OR HOT TUB AREA BY A PERMANENT BARRIER SHALL BE BONDED TOGETHER.

ALUMINUM SPECIFICATIONS:

1. ALUMINUM EXTRUSIONS SHALL BE 6005 T5 ALLOY UNLESS OTHERWISE NOTED.
2. ALL SELF MATING BEAM SECTIONS ARE TO BE STITCHED WITH
 - a. #14 SCREWS 6" FROM ENDS & 24" CENTER TO CENTER.
 - b. #12 SCREWS 6" FROM ENDS & 18" CENTER TO CENTER.
 - c. #10 SCREW 6" FROM ENDS & 12" CENTER TO CENTER.
3. ROOF BRACING SHALL BE A MINIMUM 2"x3"x.050".
4. THE MINIMUM NORMAL THICKNESS OF PROTECTOR PANELS (KICKPLATES) SHALL BE AN INDUSTRY STANDARD OF 0.024 INCHES.
5. SCREEN MATERIAL SHALL BE 18/14 SCREEN UNLESS APPROVED BY FLORIDA ENGINEERING LLC.
6. 1"x2" & 1"x3" NON-STRUCTURAL MEMBERS MAY BE USED INTERCHANGEABLY.
7. DOOR LOCATION MAY BE DETERMINED/ RELOCATED BY CONTRACTOR IN THE FIELD. NOT TO AFFECT DESIGN SPANS AND STRUCTURAL MEMEBRS SHOWN

CONCRETE SPECIFICATIONS:

THE FOLLOWING SPECIFICATIONS ARE APPLICABLE TO THIS PROJECT:

1. WHERE CONCRETE SPECIFICATIONS ARE REQUIRED, WHETHER IN THE SCREEN ENCLOSURE SCOPE OR NOT, BY ONE OR MORE REGULATORY AGENCIES, THE FOLLOWING SPECIFICATIONS ARE APPLICABLE:
 - a. CONCRETE SHALL CONFORM TO ASTM C94 FOR THE FOLLOWING COMPONENTS:
 - i. PORTLAND CEMENT TYPE 1 - ASTM C 150
 - ii AGGREGATES - LARGE AGGREGATE 3/4 MAX. - ASTM C 33
 - iii. AIR ENTRAINING +/- 1 % - ASTM C 260
 - iv. WATER REDUCING AGENT - ASTM C 494
 - v. CLEAN POTABLE WATER
 - vi. OTHER ADMIXTURES NOT PERMITTED
 - b. METAL ACCESSORIES SHALL CONFORM TO:
 - i. REINFORCING BARS - ASTM A615, GRADE 60
 - ii. WELDED WIRE FABRIC - ASTM A185
 - c. CONCRETE SLUMP AT DISCHARGE CHUTE NOT LESS THAN 3" OR MORE THAN 5". WATER ADDED AFTER BATCHING IS NOT PERMITTED.
 - d. PREPARE & PLACE CONCRETE PER AMERICAN CONCRETE INSTITUTE MANUAL OF STANDARD PRACTICE, PART 1, 2, & 3 INCLUDING HOT WEATHER RECOMMENDATIONS.
 - e. MOIST CURE OR POLYETHYLENE CURING PERMITTED.
 - f. PRIOR TO PLACING CONCRETE, TREAT THE ENTIRE SUBSURFACE AREA FOR TERMITES IN COMPLIANCE WITH THE FBC. FOR RISK CATEGORY II, III, & IV STRUCTURES ONLY.
 - g. CONCRETE SLAB SHALL BE PLACED OVER A POLYETHYLENE VAPOR BARRIER. (SLAB ONLY)
2. WHEN PAVERS ARE UNDER ALUMINUM MEMBERS, CONTRACTOR SHALL EPOXY TO DECK OR GROUT TO DECK w/ 2000 PSI GROUT WITH BONDING AGENT
3. WHEN APPLICABLE FOR NEW SLAB ADDITION TO ADJACENT DRILL & EPOXY # 4 X 8" REBAR INTO EX. FOUNDATION EMBED 4" MIN W/ NON-SHRINKING SIMPSON EPOXY-TIE (OR EQUAL) 48" O.C. TYP. ALL LOCATIONS
4. WHEN APPLICABLE FOR NEW FOOTER TO EXISTING, DRILL & EPOXY NEW STEEL INTO EX. FOUNDATION WITH EMBED 6" MIN W/ NON-SHRINKING SIMPSON EPOXY-TIE (OR EQUAL) TYP. ALL LOCATIONS
5. WHERE PAVERS ARE UNDER ALUMINUM MEMBERS, CONTRACTOR SHALL EPOXY TO DECK OR GROUT TO DECK w/3000 PSI GROUT WITH BONDING AGENT.
6. MINIMUM CONCRETE STRENGTH 3000 PSI UNLESS OTHERWISE NOTED.

MASONRY SPECIFICATIONS:

1. CONCRETE MASONRY UNITS (CMU) SHALL BE STANDARD HOLLOW UNITS AND SHALL BE 1900 PSI MINIMUM BASED ON TYPE M OR S MORTAR.
2. ALL MORTAR SHALL BE TYPE M OR S.
3. ALL GROUT SHALL BE 1800 PSI MINIMUM AND HAVE MAXIMUM COARSE AGGREGATE SIZE OF 3/8".
4. PROVIDE CLEAN-OUTS FOR REINFORCED CELLS CONTAINING REINFORCEMENT WHEN GROUT POUR EXCEEDS 5'-0" IN HEIGHT.

FOOTER SPECIFICATIONS:

1. PROVIDE 1-1/2" COVERAGE TOP, SIDES, BOTTOM AND 1" BETWEEN ADJACENT REBAR LAPS.
2. PROVIDE MIN. 3" COVERAGE OF REBAR FOR ALL CONCRETE IN CONTACT WITH THE EARTH.
3. FOOTING CONCRETE SHALL BE MIN. 3000 PSI AT 28 DAYS
4. FOOTING REINFORCEMENT SHALL BE MIN. GRADE 60
5. MINIMUM REBAR LAP SPLICE (40d) d= DIAMETER OF REBAR
6. PROVIDE POSITIVE DRAINAGE AWAY FROM STRUCTURE TO CITY / CO. REQUIREMENTS
7. PROVIDE 2500 PSF BEARING (TYPICAL) UNDER FOUNDATION
8. SEE GENERAL NOTES SHEET/01 FOR TYING INTO EXISTING FOUNDATIONS
9. SEE GENERAL NOTES SHEET/01 FOR ADDITIONAL CONCRETE INFORMATION & SPECS.

ALUMINUM MEMBERS DIMENSIONS:

HOLLOW SECTIONS
 2 x 2: 2" x 2" x 0.050"
 2 x 3: 2" x 3" x 0.050"
 2 x 4: 2" x 4" x 0.050"
 2 x 5: 2" x 5" x 0.050"

OPEN BACK SECTIONS
 1 x 2: 1" x 2" x 0.044"
 1 x 3: 1" x 3" x 0.045"

SNAP SECTIONS
 2 x 2 SNAP: 2" x 2" x 0.045"
 2 x 3 SNAP: 2" x 3" x 0.050"
 2 x 4 SNAP: 2" x 4" x 0.045"

SELF MATING (SMB)
 2 x 4 SMB: 2" x 4" x 0.046" x 0.100"
 2 x 5 SMB: 2" x 5" x 0.050" x 0.116"
 2 x 6 SMB: 2" x 6" x 0.050" x 0.120"
 2 x 7 SMB: 2" x 7" x 0.055" x 0.120"
 2 x 8 SMB: 2" x 8" x 0.072" x 0.224"
 2 x 9 SMB: 2" x 9" x 0.072" x 0.224"
 2 x 9(H) SMB: 2" x 9" x 0.082" x 0.306"
 2 x 10 SMB: 2" x 10" x 0.092" x 0.374"

ALL MAY NOT APPLY
 DETAIL "A" MEMEBR DIMENSIONS

DESIGN LOADS:

1. DEAD LOADS =	MEMBER SELF-WEIGHT
2. LIVE LOADS	
a. PRIMARY MEMBERS =	300 LB. VERT. LOAD
b. SECONDARY MEMBERS =	200 LB. VERT. LOAD
c. SCREEN ROOF =	5 PSF
d. SOLID ROOF =	20 PSF

3-D FINITE ELEMENT ANALYSIS
 PERFORMED STRUCTURE COMPLIES
 W/ FBC 2023 8th EDITION

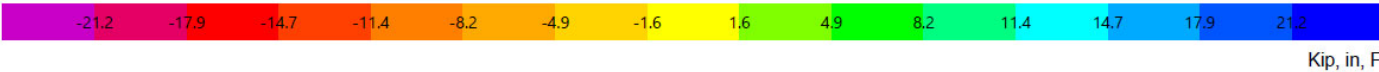
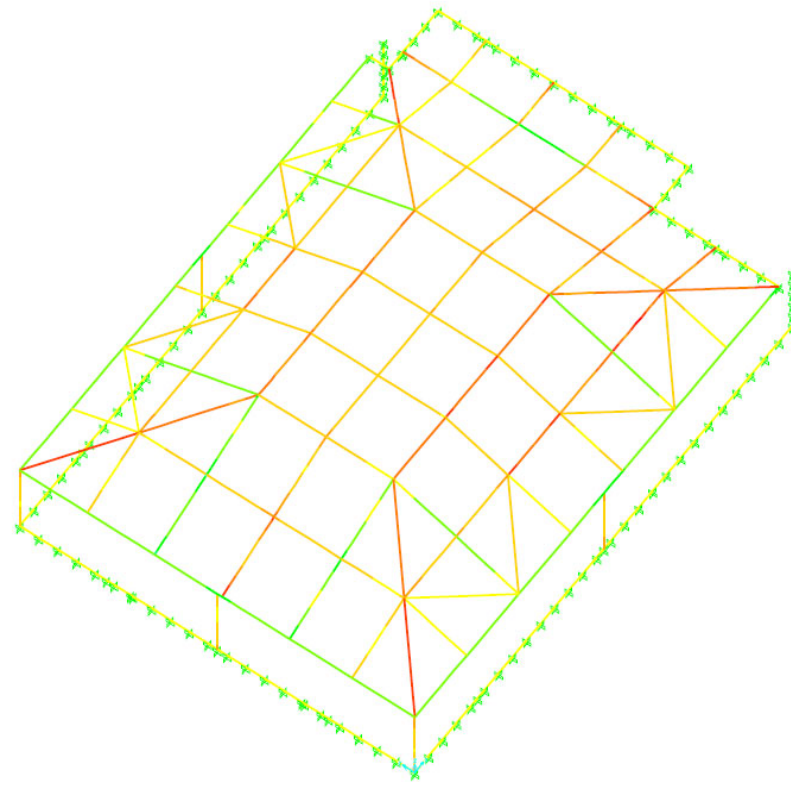

This item has been digitally signed and sealed by Richard E. Walker, P.E. on the date adjacent to the seal. Printed copies of this document are not considered signed and sealed and the signature must be verified on any electronic copies.

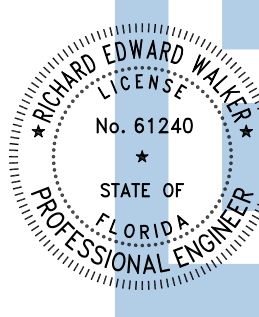

Digitally signed by
 Richard E Walker
 Date: 2025.01.10
 15:32:48-05'00'

SHEET NO.	DRAWING INDEX
S/01	GENERAL NOTES
S/02	PLAN/ ELEVATIONS
S/03	DETAILS
S/04	DETAILS
S/05	DETAILS

FLORIDA ENGINEERING LLC
 4161 TAMiami TRAIL, UNIT 101
 PORT CHARLOTTE, FLORIDA 33952
 (941) 391-5980
 FLEng.com
 Orders@FLEng.com

PROJECT NO. 2435303

CA CERT. #50782

CONTRACTOR:
 AMERICAN METALS LLC
 5000 NW 27 CT SUITE D
 GAINESVILLE, FL 32603

PROJECT ADDRESS:
 PEELER POOL HUCHIGSON
 355 SWEETBREEZE DR
 LAKE CITY FL 32024

DESIGN DATE:	01/10/2025
REVISION 1:	DATE
REVISION 2:	DATE
DRAWN BY:	MBG
SCALE:	NTS

SHEET:
01

Kip, in, F

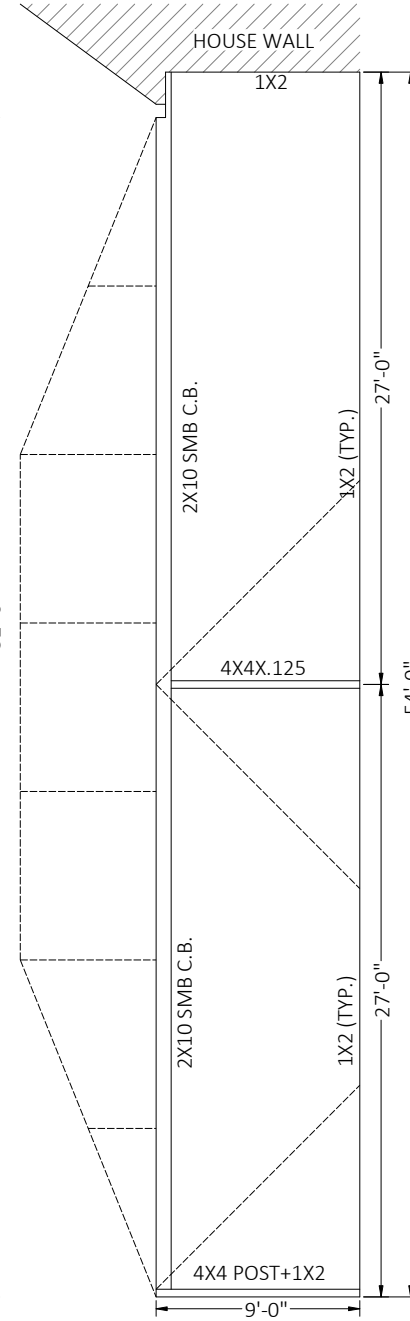
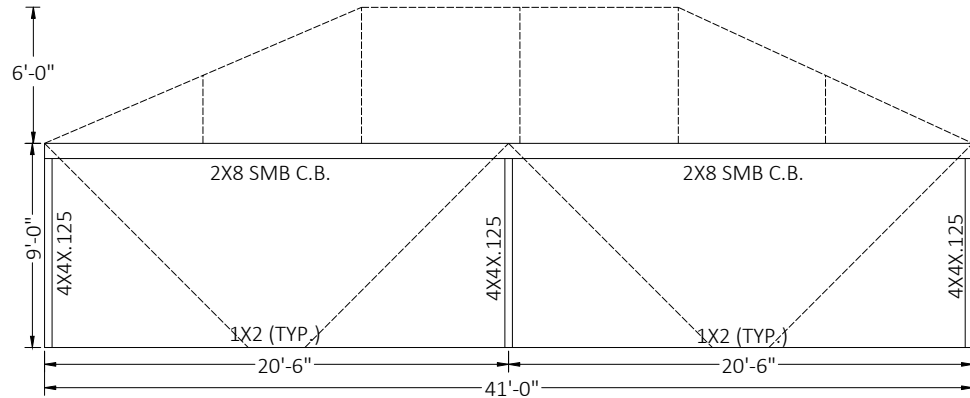
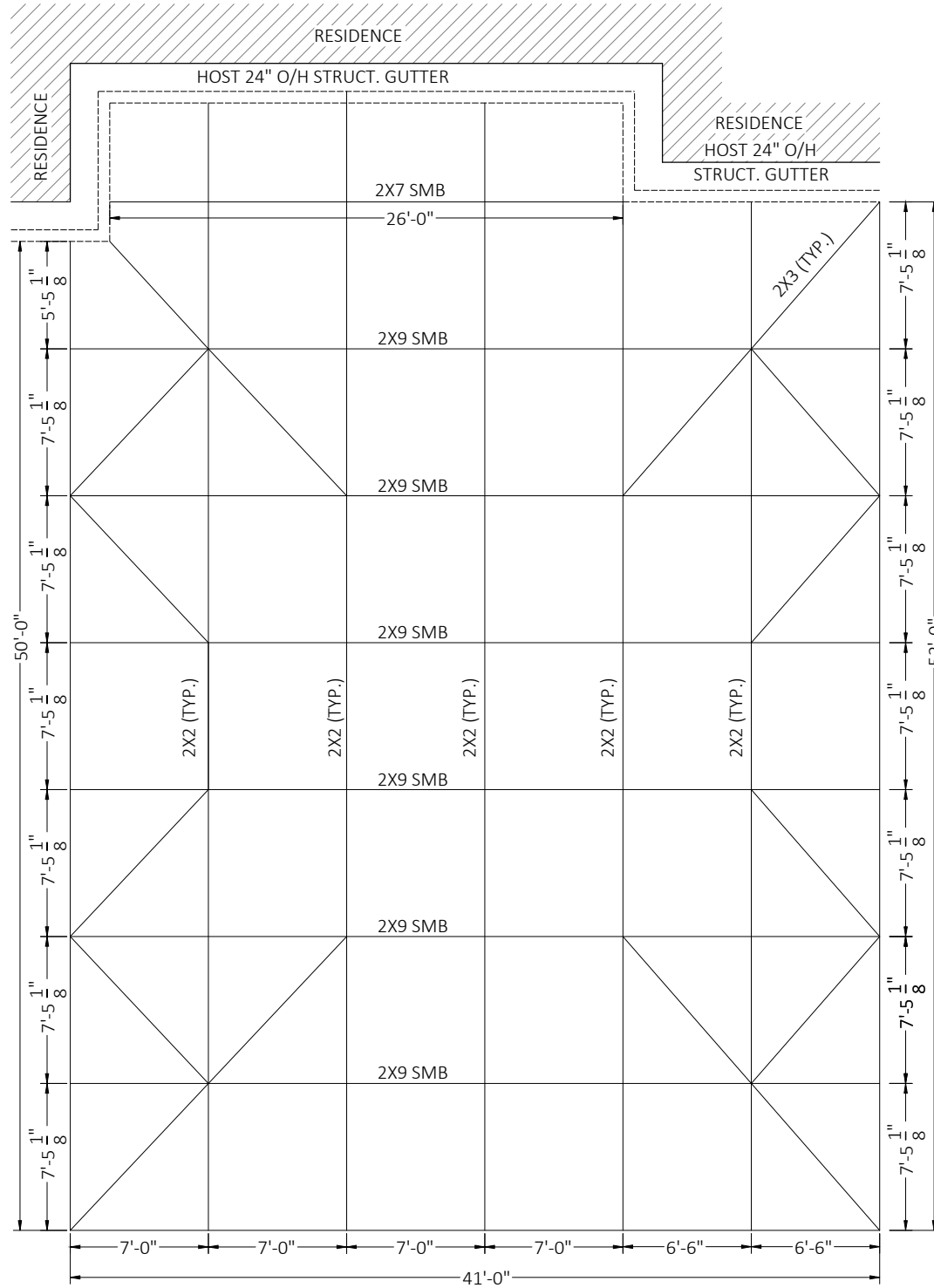
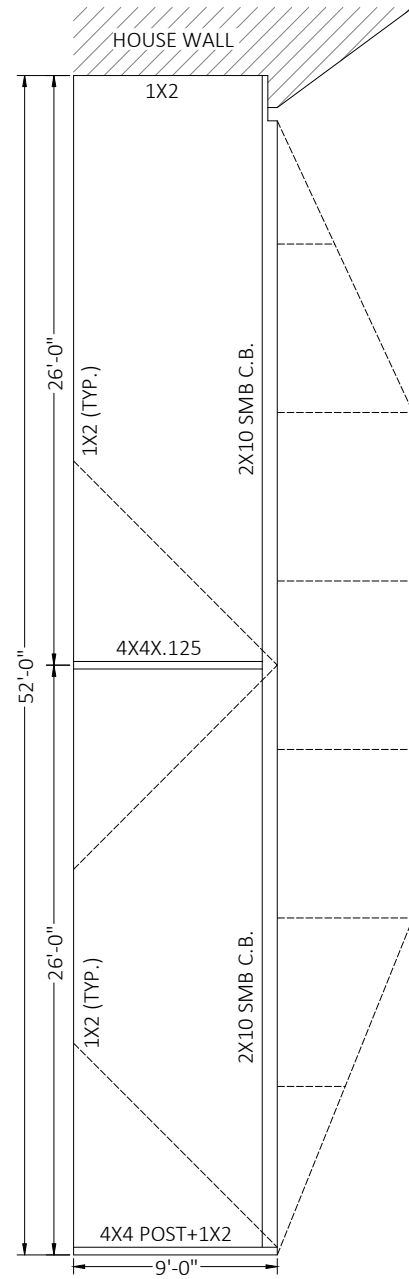

PROPOSED MANSARD SCREEN ENCLOSURE

This item has been digitally signed and sealed by Richard E. Walker, P.E. on the date adjacent to the seal. Printed copies of this document are not considered signed and sealed and the signature must be verified on any electronic copies.

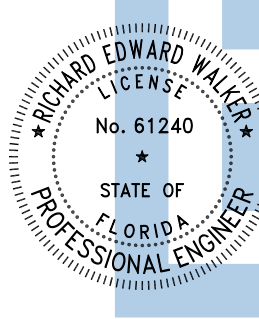

Digitally signed by Richard E Walker
 Date: 2025.01.10 15:32:48-05'00'

HATCH/ SYMBOL LEGEND

HATCH	INDICATES
	EXIST. STRUCTURE

NOTE: ALL MAY NOT APPLY

ALL PURLINS TO BE 2x2x.046 (TYP.)
 ALL ROOF BRACING TO BE 2x3x.050 (TYP.)

FLORIDA ENGINEERING LLC
 4161 TAMiami TRAIL, UNIT 101
 PORT CHARLOTTE, FLORIDA 33952
 (941) 391-5980
 FLEng.com
 Orders@FLEng.com

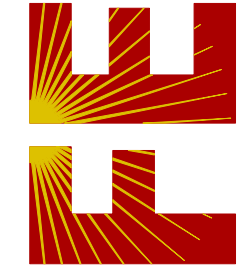

PROJECT NO. 2435303

CA CERT. #30782

CONTRACTOR:
 AMERICAN METALS LLC
 5000 NW 27 CT SUITE D
 GAINESVILLE, FL 32603

PROJECT ADDRESS:
 PEELER POOL HUCHINGSON
 355 SWEETBREEZE DR
 LAKE CITY FL 32024

DESIGN DATE:	01/10/2025
REVISION 1:	DATE
REVISION 2:	DATE
DRAWN BY:	MBG
SCALE:	NTS

SHEET:
02

NOTES:
1. FOR MOMENT CONNECTION SEE DETAIL "K"
TABLE "B-1"

1"x2" FASTEN TO COL. (INTERNAL)
w/(2) #10x1-1/2" SMS, FASTEN TO
EAVE RAILS ABOVE w/#10 1-1/2" SMS
24" O.C. AND 6" WITHIN COL.

TABLE "D"

BEAM	QTY/ SIZE EACH SIDE
2 x 3	(4)/ #12
2 x 4	(5)/ #12
2 x 5	(5)/ #12
2 x 6	(6)/ #12
2 x 7	(7)/ #12
2 x 8	(8)/ #14
2 x 9	(9)/ #14
2 x 10	(9)/ #14

MAINTAIN MIN. OF 5/8" SEPERATION
FROM EDGE OF BEAM SMS O.C.

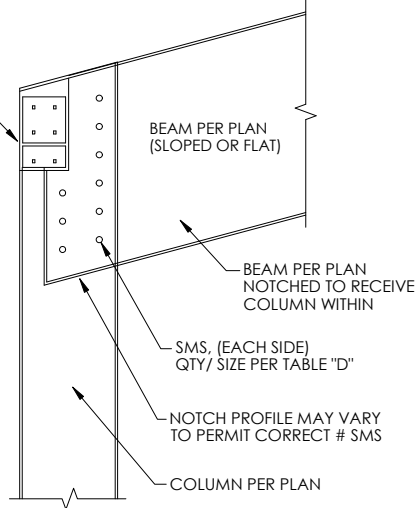

DETAIL "E" - UPRIGHT TO BEAM
CONNECTION SCALE: NTS

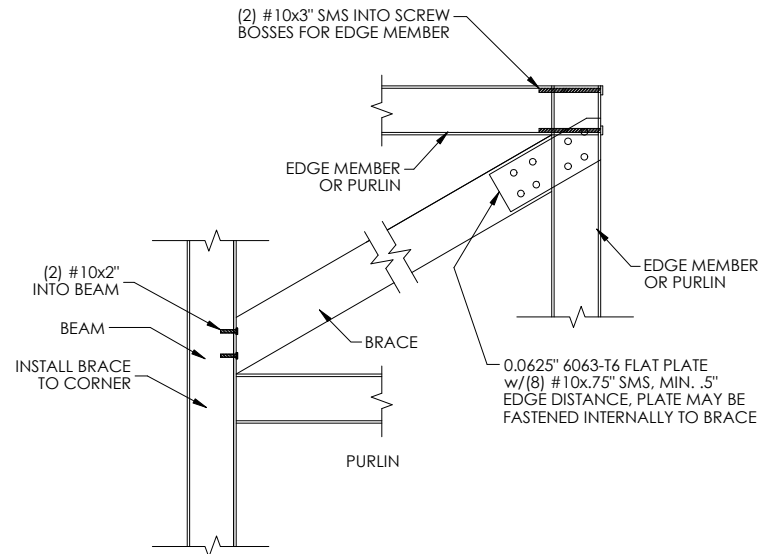

DETAIL "D" - ROOF BRACING CONNECTION
SCALE: NTS

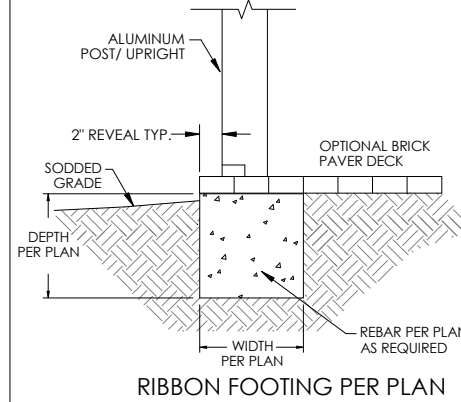

RIBBON FOOTING PER PLAN

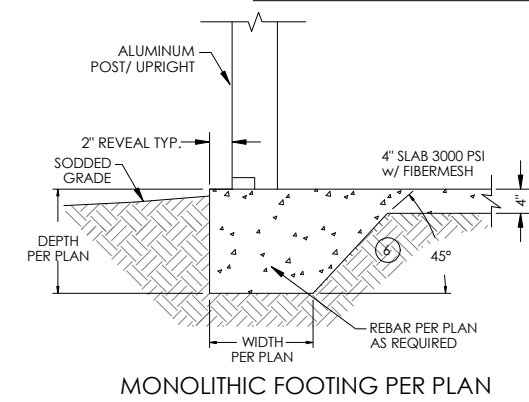

MONOLITHIC FOOTING PER PLAN

DETAIL "J" REVEAL
SCALE: NTS

This item has been digitally signed
and sealed by Richard E. Walker,
P.E. on the date adjacent to the seal.
Printed copies of this document are
not considered signed and sealed
and the signature must be verified on
any electronic copies.

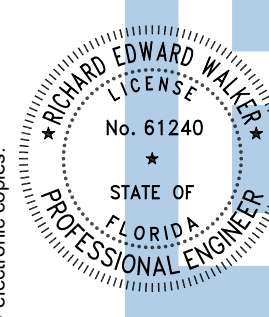

Digitally
signed by
Richard E
Walker
Date:
2025.01.10
15:32:49-05'00'

TABLE "B-2" 2"x4" OR LARGER SELF MATING
UPRIGHT TO DECK DETAIL SPECIFICATIONS

UPRIGHT SIZE	MIN. NUMBER OF TAPCONS INTO CONCRETE EA. SIDE TYP.	# 12 X 3/4" S.M.S. INTO UPRIGHT EA. SIDE TYP.
2 x 4	(2) 1/4" TAPCON	(2) #12 S.M.S
2 x 5	(2) 1/4" TAPCON	(4) #12 S.M.S
2 x 6	(3) 1/4" TAPCON	(5) #12 S.M.S
2 x 7	(3) 1/4" TAPCON	(6) #12 S.M.S
2 x 8	(4) 1/4" TAPCON	(7) #12 S.M.S
2 x 9	(4) 1/4" TAPCON	(8) #12 S.M.S
2 x 10	(5) 1/4" TAPCON	(9) #12 S.M.S

TABLE "B-2" NOTES

NOTES:
1. WHERE PAVERS ARE PRESENT USE 3/8" DIA. x
5"-7" LDT TO PENETRATE UNDERLYING
CONCRETE FOOTING 2-1/4" (MIN.)
2. CONTRACTOR MAY UTILIZE EQUIVALENT
ANCHORS IN LIEU OF TAPCONS
3. SPACING OF TAPCONS/ MASONRY
ANCHORS PER MFG.
1/4" DIA. TAPCON MIN. 2" SPACING
3/8" DIA. LDT's MIN. 3" SPACING

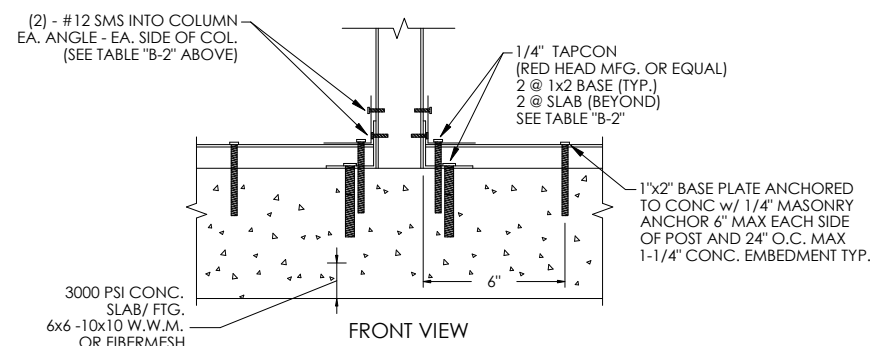
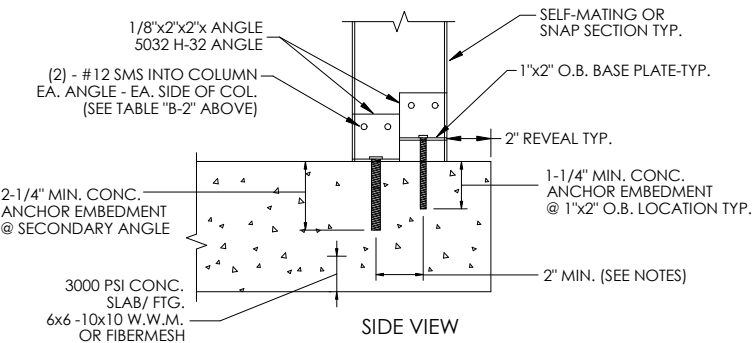

DETAIL "B" - 2"x4" OR LARGER SELF MATING
UPRIGHT TO DECK DETAILS SCALE: NTS

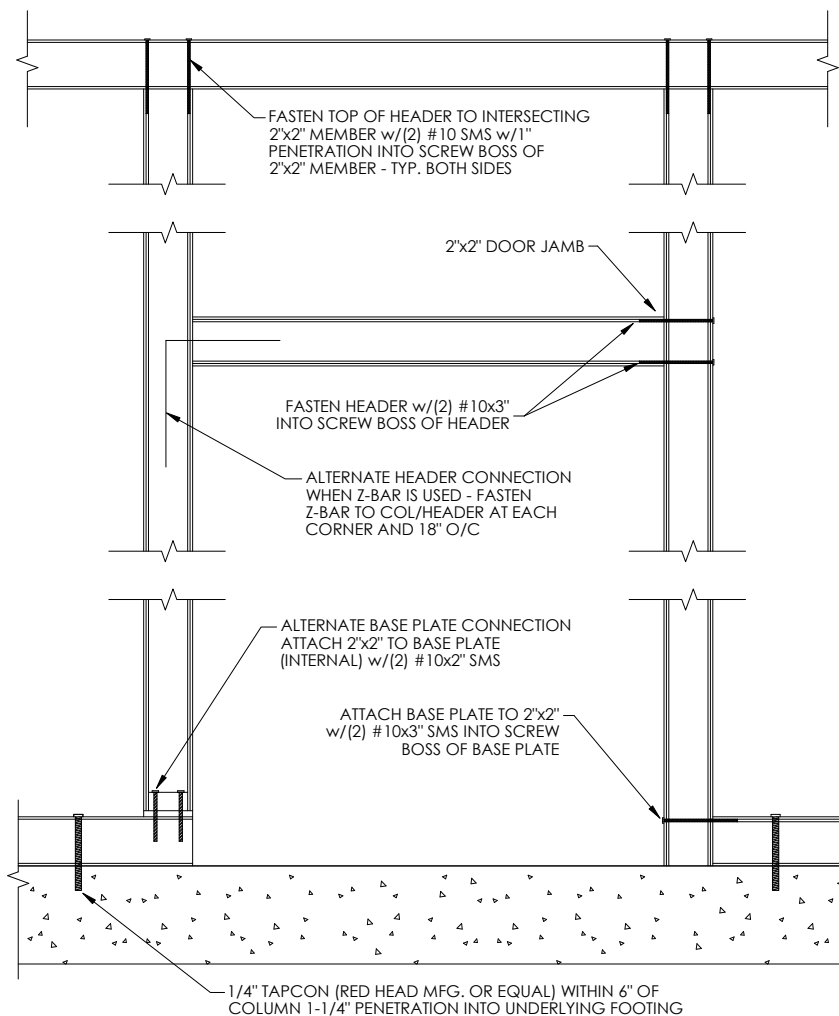

DETAIL "F" - DOOR JAMB & HEADER
CONNECTION SCALE: NTS

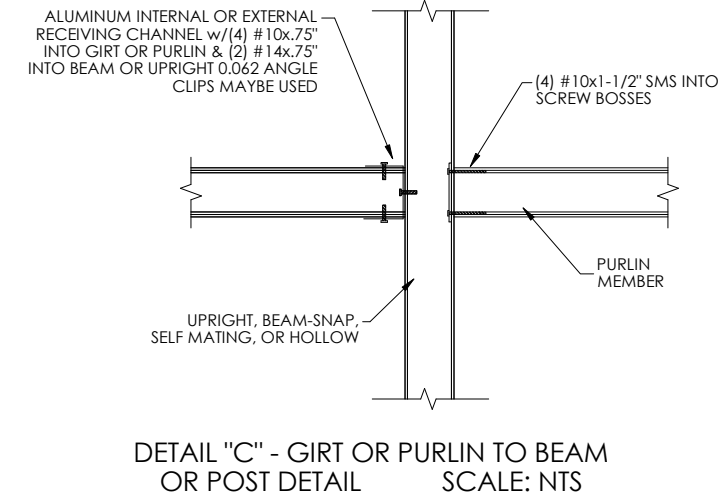

DETAIL "C" - GIRT OR PURLIN TO BEAM
OR POST DETAIL SCALE: NTS

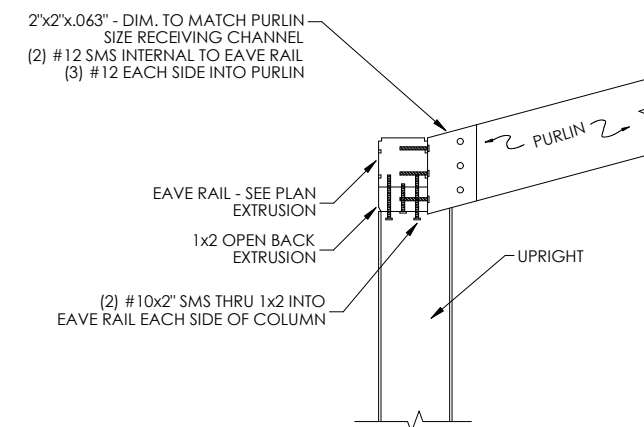

DETAIL "G" - SLOPED PURLIN
CONNECTION SCALE: NTS

FLORIDA ENGINEERING LLC
4161 TAMiami TRAIL, UNIT 101
PORT CHARLOTTE, FLORIDA 33952
(941) 391-5980
FLEng.com
Orders@FLEng.com

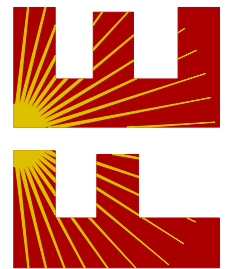

CA CERT. #30782

PROJECT NO. 2435303

CONTRACTOR:

AMERICAN METALS LLC
5000 NW 27 CT SUITE D
GAINESVILLE, FL 32603

PROJECT ADDRESS:

PEELER POOL HUCHINGSON
355 SWEETBREEZE DR
LAKE CITY FL 32024

DESIGN DATE: 01/10/2025

REVISION 1: DATE

REVISION 2: DATE

DRAWN BY: MBG

SCALE: NTS

SHEET:
03

GIRT FASTENED INTERNALLY AT EACH END w/ #10x1.5" EACH SCREW GROOVE. FASTEN TO BEAM w/ 2"x2"x1/8" ANGLE (2) #12 SMS INTO BEAM & (2) #10x1.5 THRU ANGLE INTO GUTTER WHERE NO GIRT IS PRESENT, ATTACH ANGLE DIRECTLY TO GUTTER

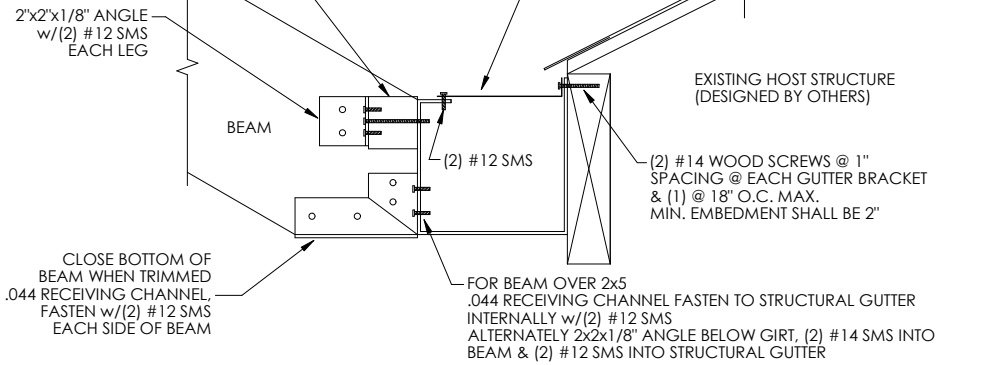

SIDE VIEW

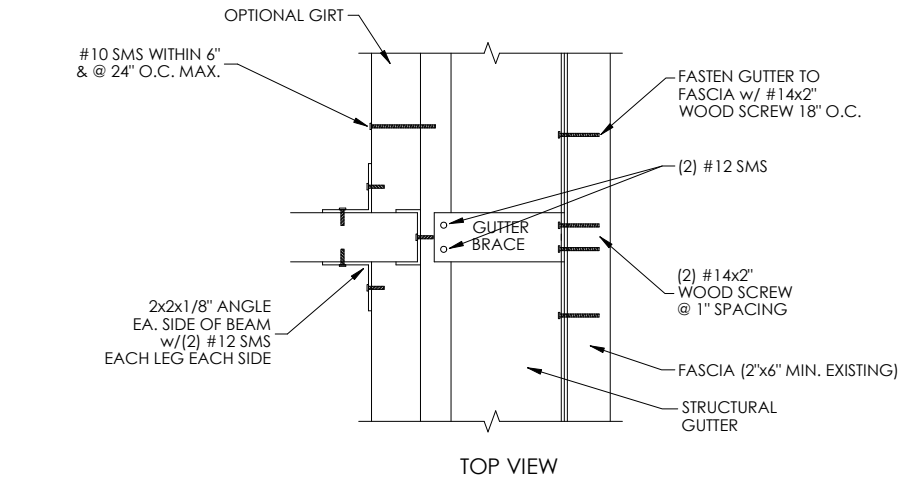

TOP VIEW

DETAIL "H" BEAM TO GUTTER CONNECTION SCALE: NTS

1"x5"x2" WIDTH EXTRUDED GUTTER BRACKET (THICKNESS OF LEG @ WOOD SCREW SHALL BE 0.125" MIN., LONG LEG SHALL BE 0.072" MIN.) @ EACH BEAM w/(2) #12x3/4" SMS @ 1" SPACING INTO GUTTER LIP. FOR BEAMS ABOVE 2x8 INSTALL GUTTER BRACE AT MIDPOINT BETWEEN BEAMS & INCLUDE 2" GUTTER BRACE AT EACH BEAM LOCATION.

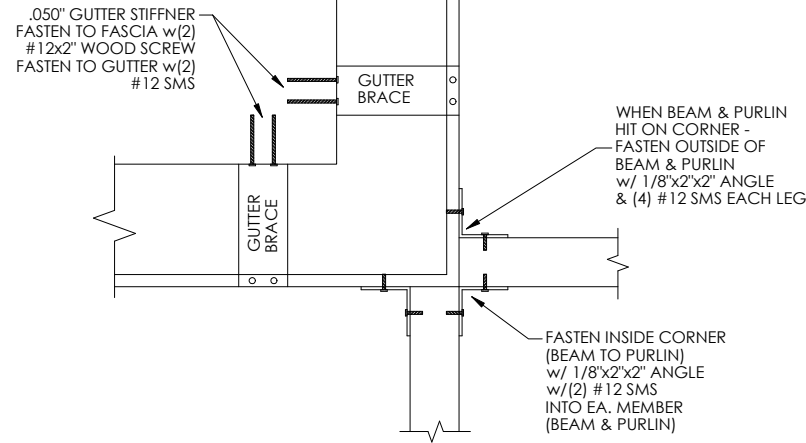

DETAIL "M" BEAM & PURLIN TO GUTTER CONNECTION SCALE: NTS

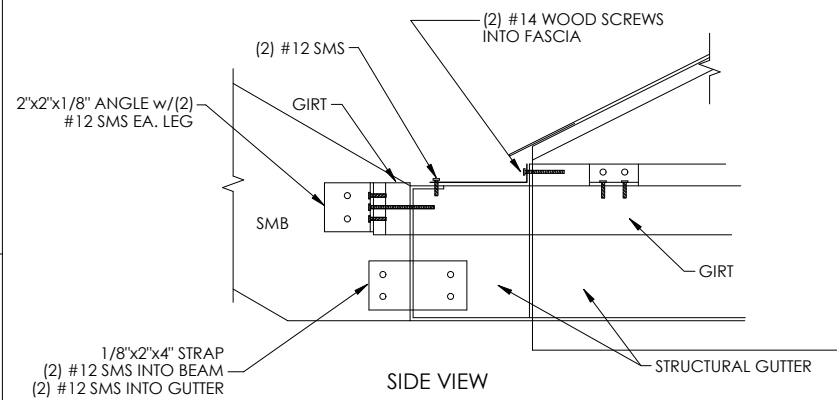

SIDE VIEW

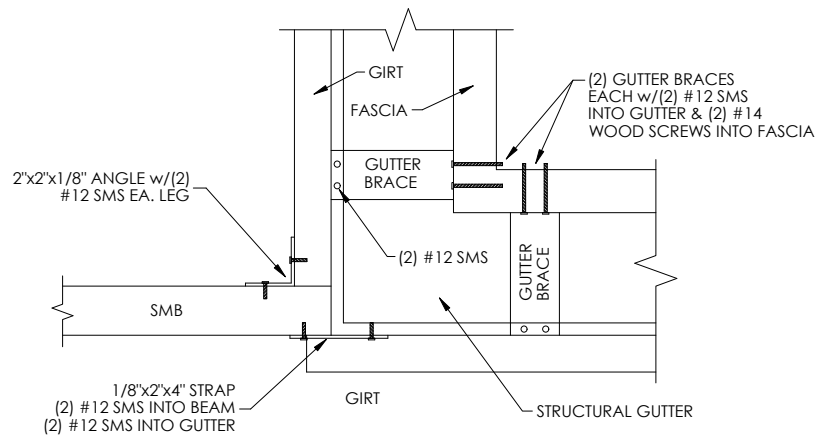

TOP VIEW

DETAIL "L" CORNER CONNECTION SCALE: NTS

This item has been digitally signed and sealed by Richard E. Walker, P.E. on the date adjacent to the seal. Printed copies of this document are not considered signed and sealed and the signature must be verified on any electronic copies.

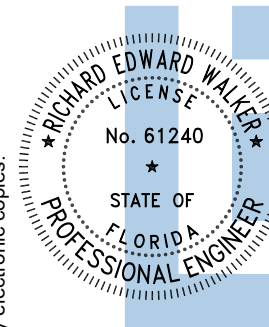

Digitally signed by Richard E Walker
Date: 2025.01.10 15:32:49-05'00'

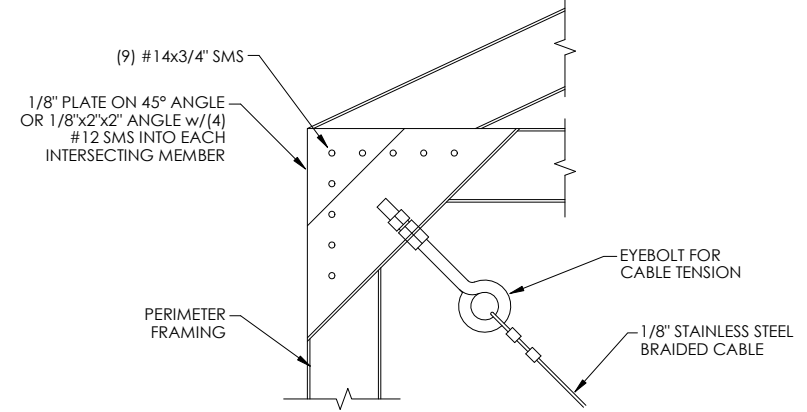

DETAIL "I-2" CABLE CONNECTION AT CORNER SCALE: NTS

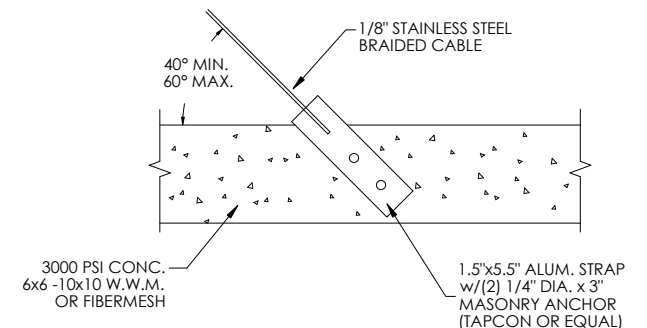
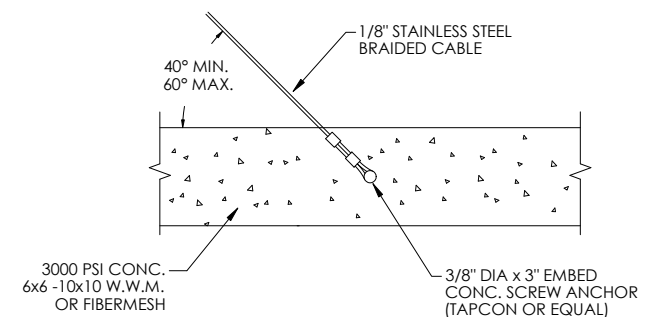
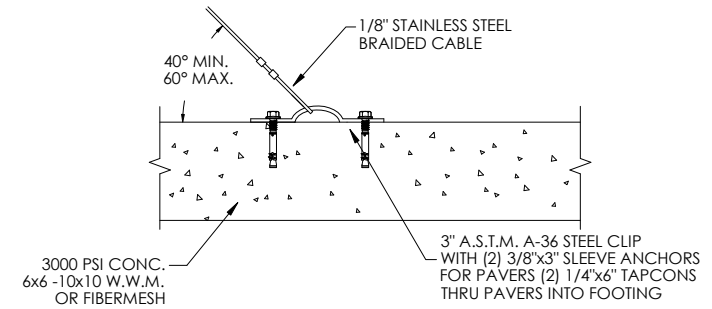

DETAIL "I-1" CABLE CONNECTION AT FOUNDATION SCALE: NTS

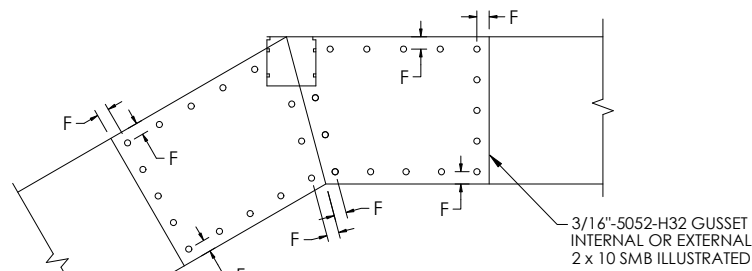

NOTE F
INSTALL FASTENERS ALONG PERIMETER OF GUSSET - BEAM JOINT 3/8" MIN. FROM EDGE. FASTENERS MAY BE STAGGERED TO INSURE PROPER QUANTITY PER TABLE B-1

FASTENER PATTERN MAY APPEAR DIFFERENT FROM ILLUSTRATION. MAINTAIN 1/2" SEPARATION BETWEEN FASTENERS. MAINTAIN 3/8" MIN. FASTENER SEPARATION FROM BEAM JOINT OR EDGE OF BEAM LAP. FASTENERS MAY BE EVENLY SPACED AROUND EDGE OF GUSSET WITHIN 3/8" OF BEAM JOINT. FASTENERS MAY BE STAGGERED TO INSURE PROPER QUANTITY PER TABLE B-1

TABLE B-1		
BEAM SIZE	COL. TO BEAM QTY SMS/ SIDE OF COL.	BEAM TO BEAM QTY SMS/ EA. FACE/SIDE
2 x 4	(5) #12	(9) #12
2 x 5	(5) #12	(9) #12
2 x 6	(7) #12	(9) #12
2 x 7	(10) #12	(10) #12
2 x 8	(12) #12	(14) #12
2 x 9	(14) #14	(14) #14
2 x 10	(16) #14	(15) #14

DETAIL "K" GUSSET CONNECTION SCALE: NTS

FLORIDA ENGINEERING LLC
4161 TAMiami TRAIL, UNIT 101
PORT CHARLOTTE, FLORIDA 33952
(941) 391-5980
FLEng.com
Orders@FLEng.com

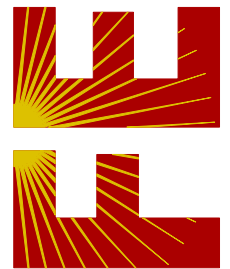

PROJECT NO. 2435303

CONTRACTOR:
AMERICAN METALS LLC
5000 NW 27 CT SUITE D
GAINESVILLE, FL 32603

PROJECT ADDRESS:
PEELER POOL HUCHINGSON
355 SWEETBREEZE DR
LAKE CITY FL 32024

DESIGN DATE: 01/10/2025
REVISION 1: DATE
REVISION 2: DATE
DRAWN BY: MBG
SCALE: NTS

SHEET: 04

CA CERT. #30782

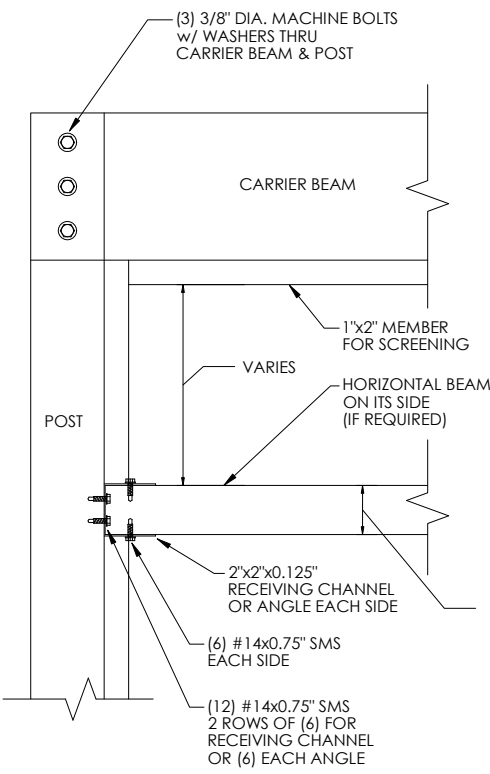

NOTES:
 1. FOR DOUBLE BEAM TO HOST, UPRIGHT OR DECK USE SIMILAR CONNECTION DETAILS AS SHOWN SHEETS 3-5.
 2. FOR DOUBLE OR TRIPLE CARRIER BEAM, OUTSIDE BEAM WEBS SHALL OVERLAP 4x4 POST OR NOTCH POST AS BELOW FOR 6x6 POST. ALL CASES, CONNECT USING MACHINE BOLTS DESCRIBED BELOW.

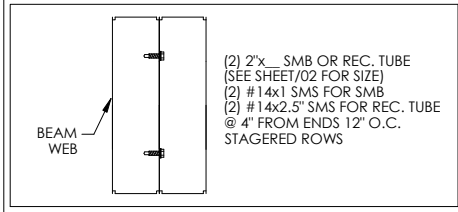

2" FOR SINGLE HORIZONTAL BEAM
 4" FOR DOUBLE HORIZONTAL BEAM OR 4"x4"
 6" FOR TRIPLE HORIZONTAL BEAM OR 6x6

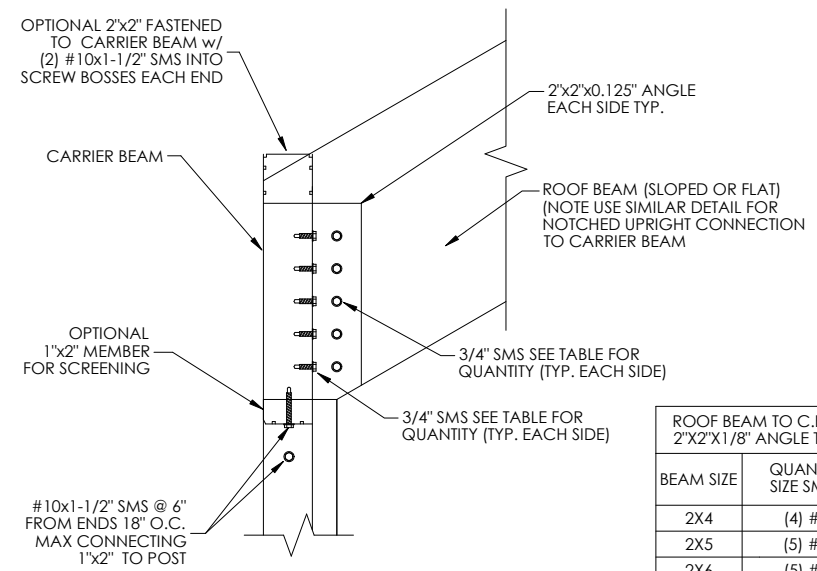

ROOF BEAM TO CARRIER BEAM CONNECTION DETAIL SCALE: NTS

BEAM SIZE	QUANTITY / SIZE SMS
2X4	(4) #12
2X5	(5) #12
2X6	(5) #12
2X7	(6) #14
2X8	(7) #14
2X9	(8) #14
2X10	(9) #14

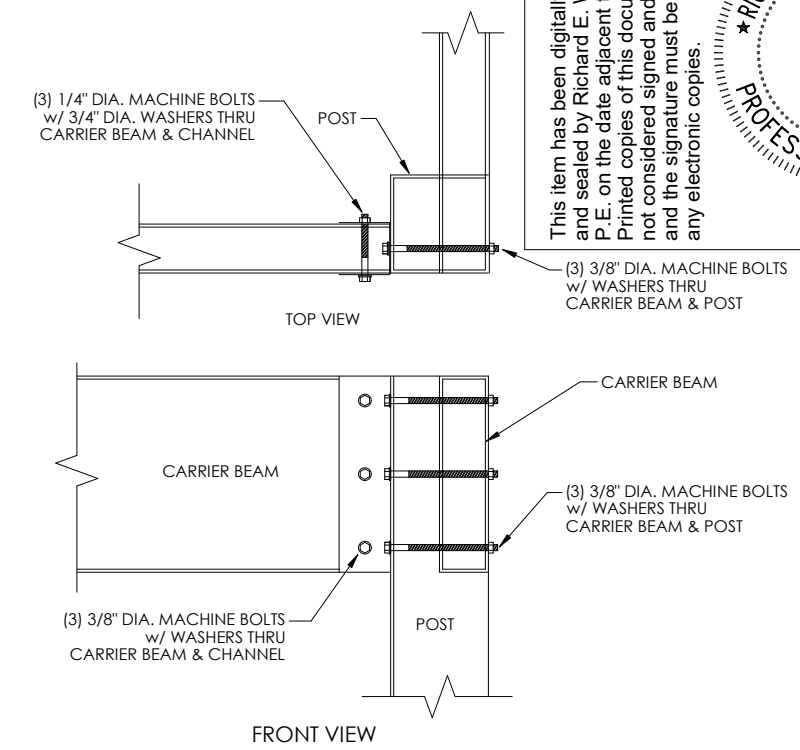

CORNER CARRIER BEAM CONNECTION DETAIL SCALE: NTS

CARRIER BEAM TO POST CONNECTION DETAIL SCALE: NTS

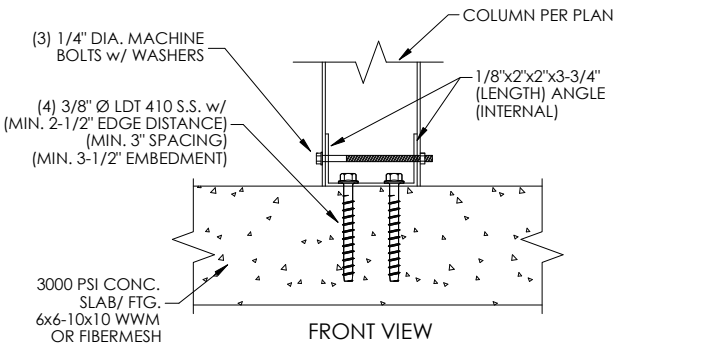
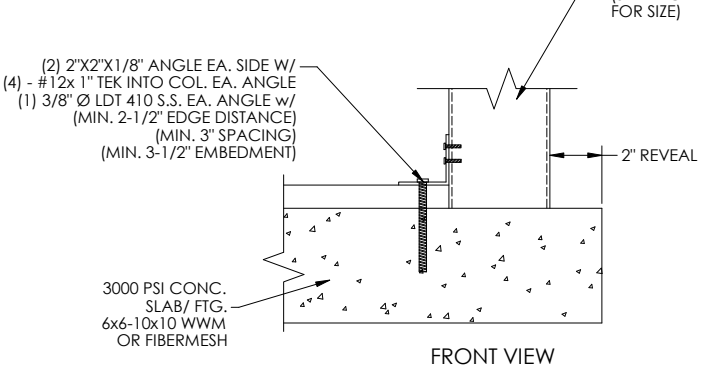
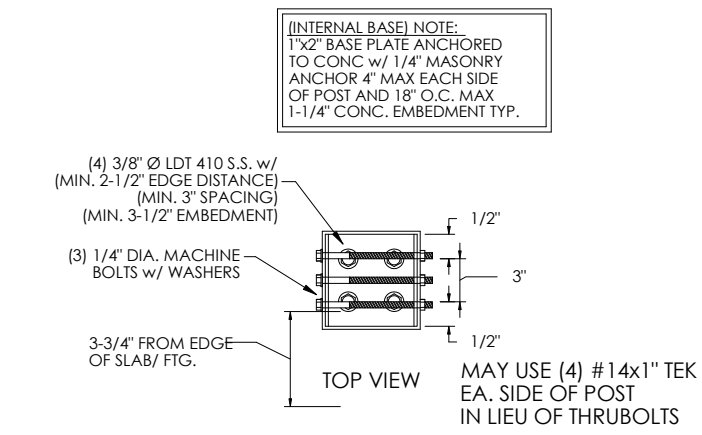
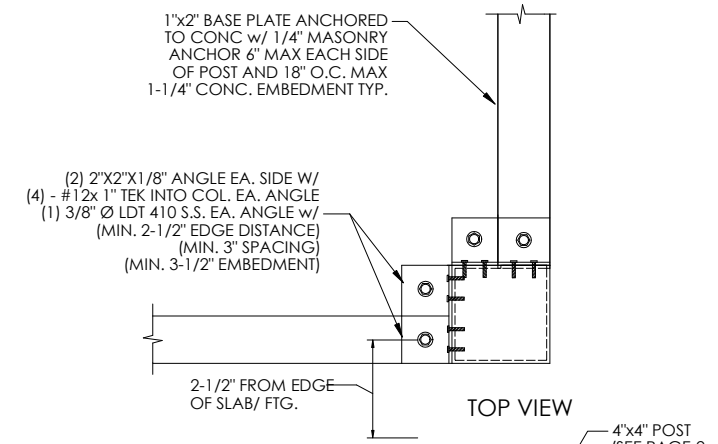

4"x4" POST CONNECTION DETAIL SCALE: N.T.S.

4"x4" POST CONNECTION DETAIL (INTERNAL BASE) SCALE: NTS

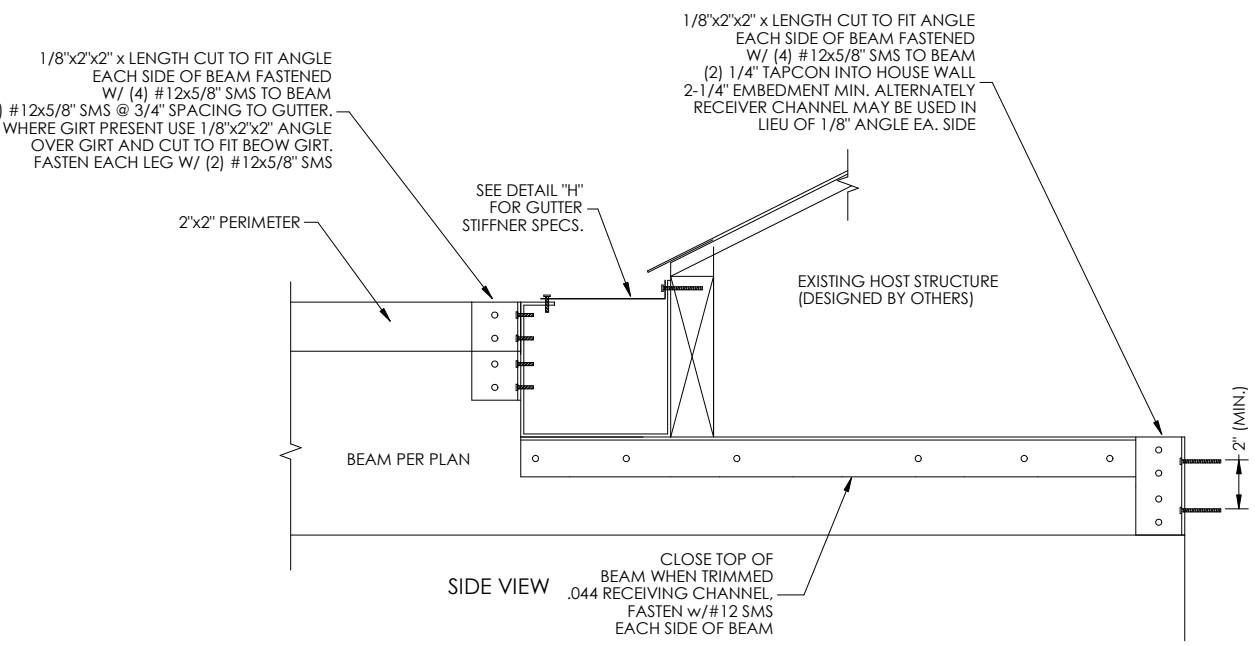

BEAM TO GUTTER/HOST CONNECTION DETAIL SCALE: NTS

NOTES:
 1. 3x3 POST TO HAVE 3/8" RED HEAD - TRUBOLT WEDGE ANCHORS (STAINLESS STEEL, PROVIDE MINIMUM 2" FROM EDGE OF SLAB AND PROVIDE MINIMUM 2" SPACING TO ANY OTHER CONNECTOR. SEE MFG. NOTES FOR INSTALLATION REQUIREMENTS. THREADED ROD REQUIRES 3" MINIMUM EDGE DISTANCE.
 2. WHERE 4x4 POST HAVE 1/2" RED HEAD - TRUBOLT WEDGE ANCHORS (STAINLESS STEEL), PROVIDE MINIMUM 3-3/4" FROM EDGE OF SLAB AND PROVIDE MINIMUM 3-3/4" SPACING TO ANY OTHER CONNECTOR. SEE MFG. NOTES FOR INSTALLATION REQUIREMENTS.
 3. WHERE PAVERS ARE PRESENT ANCHOR LENGTH SHALL BE INCREASED BY THICKNESS OF PAVENOT TO EXCEED 2-1/2" FOR PAVENOT MORE THAN 2-1/2" SITE SPECIFIC SPECIFICATIONS SHALL BE REQUIRED. PAVERS SHALL BE BONDED TO UNDERLYING CONCRETE FOUNDATION W/ 3000 PSI GORUT.

This item has been digitally signed and sealed by Richard E. Walker, P.E. on the date adjacent to the seal. Printed copies of this document are not considered signed and sealed and the signature must be verified on any electronic copies.

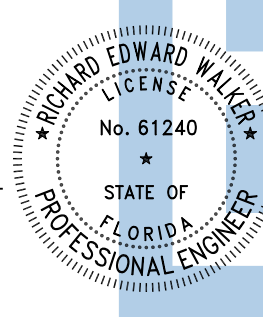

Digitally signed by Richard E Walker
 Date: 2025.01.10 15:32:49-05'00'

FLORIDA ENGINEERING LLC
 4161 TAMiami TRAIL, UNIT 101
 PORT CHARLOTTE, FLORIDA 33952
 (941) 391-5980
 FLEng.com
 Orders@FLEng.com

CA CERT. #30782

PROJECT NO. 2435303

CONTRACTOR:
 AMERICAN METALS LLC
 5000 NW 27 CT SUITE D
 GAINESVILLE, FL 32603

PROJECT ADDRESS:
 PEELER POOL HUCHINGSON
 355 SWEETBREEZE DR
 LAKE CITY FL 32024

DESIGN DATE:	01/10/2025
REVISION 1:	DATE
REVISION 2:	DATE
DRAWN BY:	MBG
SCALE:	NTS

SHEET: **05**