



Lumber design values are in accordance with ANSI/TPI 1 section 6.3
 These truss designs rely on lumber values established by others.

RE: 2918935 - IC CONST. - LIBERTY RES.

MiTek USA, Inc.
 6904 Parke East Blvd.
 Tampa, FL 33610-4115

Site Information:

Customer Info: IC CONSTRUCTION Project Name: Liberty Res. Model: Custom
 Lot/Block: N/A Subdivision: N/A
 Address: TBD, TBD
 City: Columbia Cty State: FL

Name Address and License # of Structural Engineer of Record, If there is one, for the building.

Name: License #:
 Address:
 City: State:

General Truss Engineering Criteria & Design Loads (Individual Truss Design Drawings Show Special Loading Conditions):

Design Code: FBC2020/TPI2014 Design Program: MiTek 20/20 8.4
 Wind Code: ASCE 7-16 Wind Speed: 130 mph
 Roof Load: 37.0 psf Floor Load: N/A psf

This package includes 59 individual, Truss Design Drawings and 0 Additional Drawings.
 With my seal affixed to this sheet, I hereby certify that I am the Truss Design Engineer and this index sheet conforms to 61G15-31.003, section 5 of the Florida Board of Professional Engineers Rules.

No.	Seal#	Truss Name	Date	No.	Seal#	Truss Name	Date
1	T25256402	CJ01	9/7/21	23	T25256424	T03	9/7/21
2	T25256403	CJ02	9/7/21	24	T25256425	T04	9/7/21
3	T25256404	CJ03	9/7/21	25	T25256426	T05	9/7/21
4	T25256405	CJ03A	9/7/21	26	T25256427	T05G	9/7/21
5	T25256406	CJ03B	9/7/21	27	T25256428	T06	9/7/21
6	T25256407	CJ03C	9/7/21	28	T25256429	T07	9/7/21
7	T25256408	CJ05	9/7/21	29	T25256430	T08	9/7/21
8	T25256409	CJ05A	9/7/21	30	T25256431	T09	9/7/21
9	T25256410	EJ01	9/7/21	31	T25256432	T10	9/7/21
10	T25256411	EJ02	9/7/21	32	T25256433	T11	9/7/21
11	T25256412	EJ03	9/7/21	33	T25256434	T12	9/7/21
12	T25256413	EJ04	9/7/21	34	T25256435	T13	9/7/21
13	T25256414	HJ06	9/7/21	35	T25256436	T14	9/7/21
14	T25256415	HJ10	9/7/21	36	T25256437	T15	9/7/21
15	T25256416	PB01	9/7/21	37	T25256438	T16	9/7/21
16	T25256417	PB02	9/7/21	38	T25256439	T17	9/7/21
17	T25256418	PB03	9/7/21	39	T25256440	T18	9/7/21
18	T25256419	PB03G	9/7/21	40	T25256441	T19	9/7/21
19	T25256420	PB04	9/7/21	41	T25256442	T20	9/7/21
20	T25256421	T01G	9/7/21	42	T25256443	T21	9/7/21
21	T25256422	T02	9/7/21	43	T25256444	T22	9/7/21
22	T25256423	T02G	9/7/21	44	T25256445	T23	9/7/21



The truss drawing(s) referenced above have been prepared by MiTek USA, Inc. under my direct supervision based on the parameters provided by Builders FirstSource-Lake City, FL.

Truss Design Engineer's Name: ORegan, Philip
 My license renewal date for the state of Florida is February 28, 2023.

IMPORTANT NOTE: The seal on these truss component designs is a certification that the engineer named is licensed in the jurisdiction(s) identified and that the designs comply with ANSI/TPI 1. These designs are based upon parameters shown (e.g., loads, supports, dimensions, shapes and design codes), which were given to MiTek or TRENCO. Any project specific information included is for MiTek's or TRENCO's customers file reference purpose only, and was not taken into account in the preparation of these designs. MiTek or TRENCO has not independently verified the applicability of the design parameters or the designs for any particular building. Before use, the building designer should verify applicability of design parameters and properly incorporate these designs into the overall building design per ANSI/TPI 1, Chapter 2.

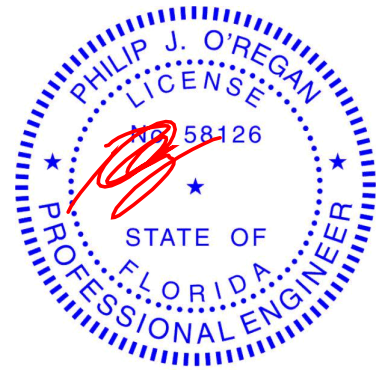

Philip J. O'Regan PE No.58126
 MiTek USA, Inc. FL Cert 6634
 6904 Parke East Blvd. Tampa FL 33610
 Date:

September 7, 2021



RE: 2918935 - IC CONST. - LIBERTY RES.

MiTek USA, Inc.
6904 Parke East Blvd.
Tampa, FL 33610-4115

Site Information:

Customer Info: IC CONSTRUCTION Project Name: Liberty Res. Model: Custom
Lot/Block: N/A Subdivision: N/A
Address: TBD, TBD
City: Columbia Cty State: FL

No.	Seal#	Truss Name	Date
45	T25256446	T24	9/7/21
46	T25256447	T25	9/7/21
47	T25256448	T26	9/7/21
48	T25256449	T27	9/7/21
49	T25256450	T28	9/7/21
50	T25256451	T29	9/7/21
51	T25256452	T30	9/7/21
52	T25256453	T30G	9/7/21
53	T25256454	T31	9/7/21
54	T25256455	T32G	9/7/21
55	T25256456	T33	9/7/21
56	T25256457	T33G	9/7/21
57	T25256458	T34	9/7/21
58	T25256459	TG01	9/7/21
59	T25256460	TG02	9/7/21

Job	Truss	Truss Type	Qty	Ply	IC CONST. - LIBERTY RES.	T25256402
2918935	CJ01	Jack-Open	1	1		

Builders FirstSource (Lake City,FL), Lake City, FL - 32055,

8.430 s Aug 16 2021 MiTek Industries, Inc. Sat Sep 4 11:23:13 2021 Page 1

ID:b2ldskJJGjOxOjHDJPP?LTyh2aU-zm3zl5T0xVoanE5Ge67wXuADJk9Ucb_B8hykRzyh12C



Scale = 1:12.9

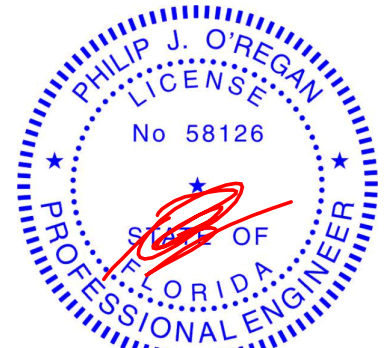
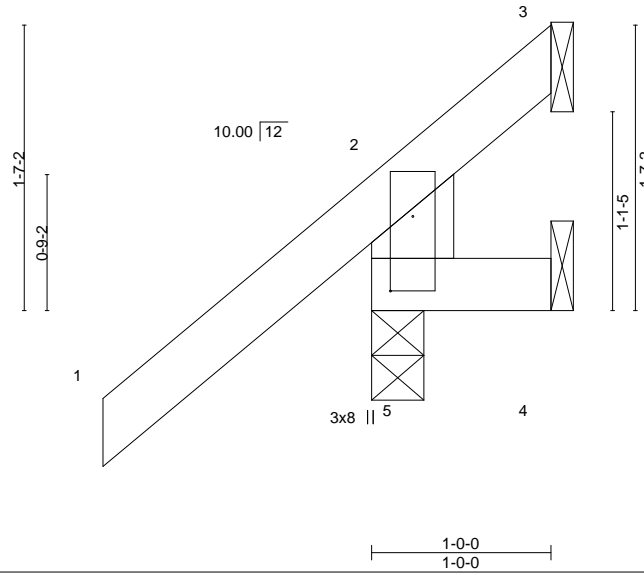

Philip J. O'Regan PE No.58126
MiTek USA, Inc. FL Cert 6634
6904 Parke East Blvd. Tampa FL 33610
Date:

Plate Offsets (X,Y)-- [5:0-5-0,0-1-8]

LOADING (psf)	SPACING-	2-0-0	CSI.	DEFL.	in (loc)	l/defl	L/d	PLATES	GRIP
TCLL 20.0	Plate Grip DOL	1.25	TC 0.35	Vert(LL)	0.00 5	>999	240	MT20	244/190
TCDL 7.0	Lumber DOL	1.25	BC 0.07	Vert(CT)	0.00 5	>999	180		
BCLL 0.0 *	Rep Stress Incr	YES	WB 0.00	Horz(CT)	0.00 3	n/a	n/a		
BCDL 10.0	Code	FBC2020/TPI2014	Matrix-MR					Weight: 8 lb	FT = 20%

LUMBER-

TOP CHORD 2x4 SP No.2
BOT CHORD 2x4 SP No.2
WEBS 2x6 SP No.2

BRACING-

TOP CHORD Structural wood sheathing directly applied or 1-0-0 oc purlins, except end verticals.
BOT CHORD Rigid ceiling directly applied or 10-0-0 oc bracing.

REACTIONS.

(size) 5=0-3-8, 3=Mechanical, 4=Mechanical
Max Horz 5=57(LC 12)
Max Uplift 5=-68(LC 12), 3=-39(LC 1), 4=-40(LC 1)
Max Grav 5=228(LC 1), 3=11(LC 16), 4=15(LC 16)

FORCES. (lb) - Max. Comp./Max. Ten. - All forces 250 (lb) or less except when shown.

NOTES-

- 1) Wind: ASCE 7-16; Vult=130mph (3-second gust) Vasd=101mph; TCDL=4.2psf; BCDL=3.0psf; h=20ft; Cat. II; Exp B; Encl., GCpi=0.18; MWFRS (envelope) gable end zone and C-C Exterior(2E) zone; end vertical left exposed;C-C for members and forces & MWFRS for reactions shown; Lumber DOL=1.60 plate grip DOL=1.60
- 2) Building Designer / Project engineer responsible for verifying applied roof live load shown covers rain loading requirements specific to the use of this truss component.
- 3) This truss has been designed for a 10.0 psf bottom chord live load nonconcurrent with any other live loads.
- 4) * This truss has been designed for a live load of 20.0psf on the bottom chord in all areas where a rectangle 3-6-0 tall by 2-0-0 wide will fit between the bottom chord and any other members.
- 5) Refer to girder(s) for truss to truss connections.
- 6) Provide mechanical connection (by others) of truss to bearing plate capable of withstanding 68 lb uplift at joint 5, 39 lb uplift at joint 3 and 40 lb uplift at joint 4.

September 7,2021

WARNING - Verify design parameters and READ NOTES ON THIS AND INCLUDED MITEK REFERENCE PAGE MII-7473 rev. 5/19/2020 BEFORE USE.

Design valid for use only with MiTek® connectors. This design is based only upon parameters shown, and is for an individual building component, not a truss system. Before use, the building designer must verify the applicability of design parameters and properly incorporate this design into the overall building design. Bracing indicated is to prevent buckling of individual truss web and/or chord members only. Additional temporary and permanent bracing is always required for stability and to prevent collapse with possible personal injury and property damage. For general guidance regarding the fabrication, storage, delivery, erection and bracing of trusses and truss systems, see

ANSI/TPI1 Quality Criteria, DSB-89 and BCSI Building Component

Safety Information available from Truss Plate Institute, 2670 Crain Highway, Suite 203 Waldorf, MD 20601



6904 Parke East Blvd.
Tampa, FL 36610

Job	Truss	Truss Type	Qty	Ply	IC CONST. - LIBERTY RES.	T25256403
2918935	CJ02	Jack-Open	2	1		

Builders FirstSource (Lake City,FL),

Lake City, FL - 32055,

8.430 s Aug 16 2021 MiTek Industries, Inc. Sat Sep 4 11:23:14 2021 Page 1

ID:b2ldskJGjOxOjHDJpp?LTyh2aU-RzcLzRUeipwRPOgSCpeA46jND7vIL2ELNLIHzQyh12B



Scale = 1:13.8

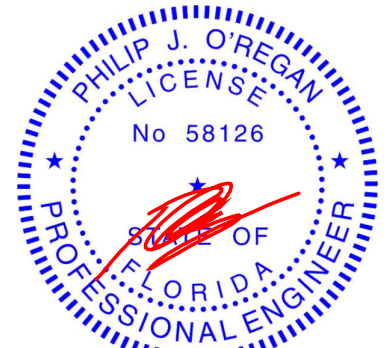
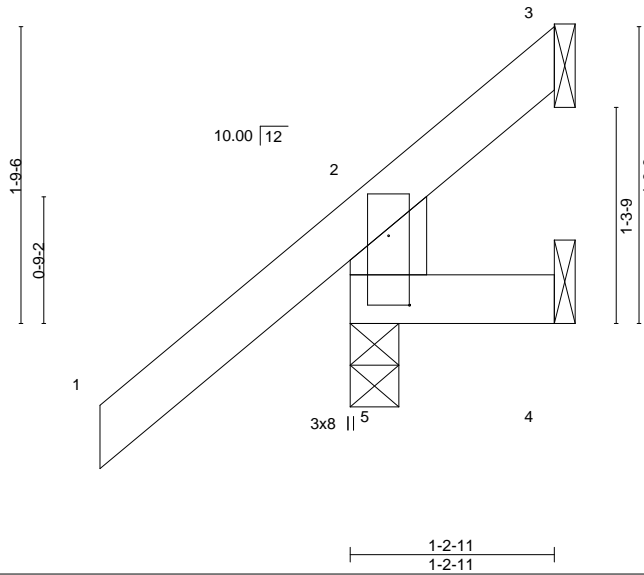

Philip J. O'Regan PE No.58126
MiTek USA, Inc. FL Cert 6634
6904 Parke East Blvd. Tampa FL 33610
Date:

Plate Offsets (X,Y)-- [5:0-5-0,0-1-8]

LOADING (psf)	SPACING-	2-0-0	CSI.	DEFL.	in (loc)	I/defl	L/d	PLATES	GRIP
TCLL 20.0	Plate Grip DOL	1.25	TC 0.34	Vert(LL)	0.00 5	>999	240	MT20	244/190
TCDL 7.0	Lumber DOL	1.25	BC 0.07	Vert(CT)	0.00 5	>999	180		
BCLL 0.0 *	Rep Stress Incr	YES	WB 0.00	Horz(CT)	-0.00 3	n/a	n/a		
BCDL 10.0	Code	FBC2020/TPI2014	Matrix-MR					Weight: 9 lb	FT = 20%

LUMBER-

TOP CHORD 2x4 SP No.2
BOT CHORD 2x4 SP No.2
WEBS 2x6 SP No.2

BRACING-

TOP CHORD Structural wood sheathing directly applied or 1-2-11 oc purlins, except end verticals.
BOT CHORD Rigid ceiling directly applied or 10-0-0 oc bracing.

REACTIONS.

(size) 5=0-3-8, 3=Mechanical, 4=Mechanical
Max Horz 5=63(LC 12)
Max Uplift 5=-56(LC 12), 3=-19(LC 1), 4=-27(LC 1)
Max Grav 5=212(LC 1), 3=9(LC 8), 4=14(LC 16)

FORCES. (lb) - Max. Comp./Max. Ten. - All forces 250 (lb) or less except when shown.

NOTES-

- 1) Wind: ASCE 7-16; Vult=130mph (3-second gust) Vasd=101mph; TCDL=4.2psf; BCDL=3.0psf; h=20ft; Cat. II; Exp B; Encl., GCpi=0.18; MWFRS (envelope) gable end zone and C-C Exterior(2E) zone; end vertical left exposed; C-C for members and forces & MWFRS for reactions shown; Lumber DOL=1.60 plate grip DOL=1.60
- 2) Building Designer / Project engineer responsible for verifying applied roof live load shown covers rain loading requirements specific to the use of this truss component.
- 3) This truss has been designed for a 10.0 psf bottom chord live load nonconcurrent with any other live loads.
- 4) * This truss has been designed for a live load of 20.0psf on the bottom chord in all areas where a rectangle 3-6-0 tall by 2-0-0 wide will fit between the bottom chord and any other members.
- 5) Refer to girder(s) for truss to truss connections.
- 6) Provide mechanical connection (by others) of truss to bearing plate capable of withstanding 56 lb uplift at joint 5, 19 lb uplift at joint 3 and 27 lb uplift at joint 4.

September 7, 2021

WARNING - Verify design parameters and READ NOTES ON THIS AND INCLUDED MITEK REFERENCE PAGE MII-7473 rev. 5/19/2020 BEFORE USE.

Design valid for use only with MiTek® connectors. This design is based only upon parameters shown, and is for an individual building component, not a truss system. Before use, the building designer must verify the applicability of design parameters and properly incorporate this design into the overall building design. Bracing indicated is to prevent buckling of individual truss web and/or chord members only. Additional temporary and permanent bracing is always required for stability and to prevent collapse with possible personal injury and property damage. For general guidance regarding the fabrication, storage, delivery, erection and bracing of trusses and truss systems, see

ANSI/TPI1 Quality Criteria, DSB-89 and BCSI Building Component

Safety Information available from Truss Plate Institute, 2670 Crain Highway, Suite 203 Waldorf, MD 20601



6904 Parke East Blvd.
Tampa, FL 36610

Job	Truss	Truss Type	Qty	Ply	IC CONST. - LIBERTY RES.	T25256404
2918935	CJ03	Jack-Open	2	1		

Builders FirstSource (Lake City,FL), Lake City, FL - 32055, 8.430 s Aug 16 2021 MiTek Industries, Inc. Sat Sep 4 11:23:15 2021 Page 1
 ID:b2ldsklJGjOxOjHDJPP?LTyh2aU-v9AjAnVGT721YFfmXAPcJFZbXrw4VUUub?RrWsyh12A

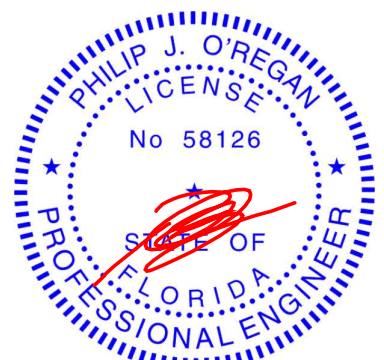
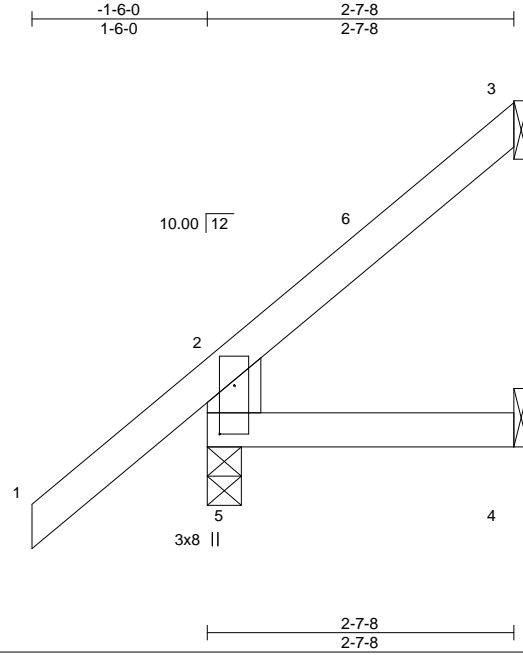

Philip J. O'Regan PE No.58126
 MiTek USA, Inc. FL Cert 6634
 6904 Parke East Blvd. Tampa FL 33610
 Date:

Plate Offsets (X,Y)--	[5:0-5-0-0-1-8]
-----------------------	-----------------

LOADING (psf)	SPACING-	CSL.	DEFL.	in (loc)	l/defl	L/d	PLATES	GRIP
TCLL 20.0	2-0-0	TC 0.30	Vert(LL)	0.00	4-5	>999	MT20	244/190
TCDL 7.0	Plate Grip DOL 1.25	BC 0.07	Vert(CT)	-0.00	4-5	>999		
BCLL 0.0 *	Lumber DOL 1.25	WB 0.00	Horz(CT)	0.00	3	n/a		
BCDL 10.0	Rep Stress Incr YES	Matrix-MR						
	Code FBC2020/TPI2014						Weight: 13 lb	FT = 20%

LUMBER-	BRACING-
TOP CHORD 2x4 SP No.2	TOP CHORD Structural wood sheathing directly applied or 2-7-8 oc purlins, except end verticals.
BOT CHORD 2x4 SP No.2	BOT CHORD Rigid ceiling directly applied or 10-0-0 oc bracing.
WEBS 2x6 SP No.2	

REACTIONS. (size) 5=0-3-8, 3=Mechanical, 4=Mechanical
 Max Horz 5=102(LC 12)
 Max Uplift 5=-31(LC 12), 3=-49(LC 12), 4=-3(LC 12)
 Max Grav 5=214(LC 1), 3=50(LC 19), 4=39(LC 3)

FORCES. (lb) - Max. Comp./Max. Ten. - All forces 250 (lb) or less except when shown.

- NOTES-**
- 1) Wind: ASCE 7-16; Vult=130mph (3-second gust) Vasd=101mph; TCDL=4.2psf; BCDL=3.0psf; h=20ft; Cat. II; Exp B; Encl., GCpi=0.18; MWFRS (envelope) gable end zone and C-C Exterior(2E) -1-6-0 to 1-6-0, Interior(1) 1-6-0 to 2-6-12 zone; end vertical left exposed; C-C for members and forces & MWFRS for reactions shown; Lumber DOL=1.60 plate grip DOL=1.60
 - 2) Building Designer / Project engineer responsible for verifying applied roof live load shown covers rain loading requirements specific to the use of this truss component.
 - 3) This truss has been designed for a 10.0 psf bottom chord live load nonconcurrent with any other live loads.
 - 4) * This truss has been designed for a live load of 20.0psf on the bottom chord in all areas where a rectangle 3-6-0 tall by 2-0-0 wide will fit between the bottom chord and any other members.
 - 5) Refer to girder(s) for truss to truss connections.
 - 6) Provide mechanical connection (by others) of truss to bearing plate capable of withstanding 31 lb uplift at joint 5, 49 lb uplift at joint 3 and 3 lb uplift at joint 4.

September 7,2021

Job	Truss	Truss Type	Qty	Ply	IC CONST. - LIBERTY RES.	T25256405
2918935	CJ03A	Jack-Open	2	1		

Builders FirstSource (Lake City,FL),

Lake City, FL - 32055,

8.430 s Aug 16 2021 MiTek Industries, Inc. Sat Sep 4 11:23:16 2021 Page 1
ID:b2ldskJGjOxOjHDJpP?LTyh2aU-NLK5O7WuEQA9eiqrJEhe9XomtqCNpykeqfBO2lyh129

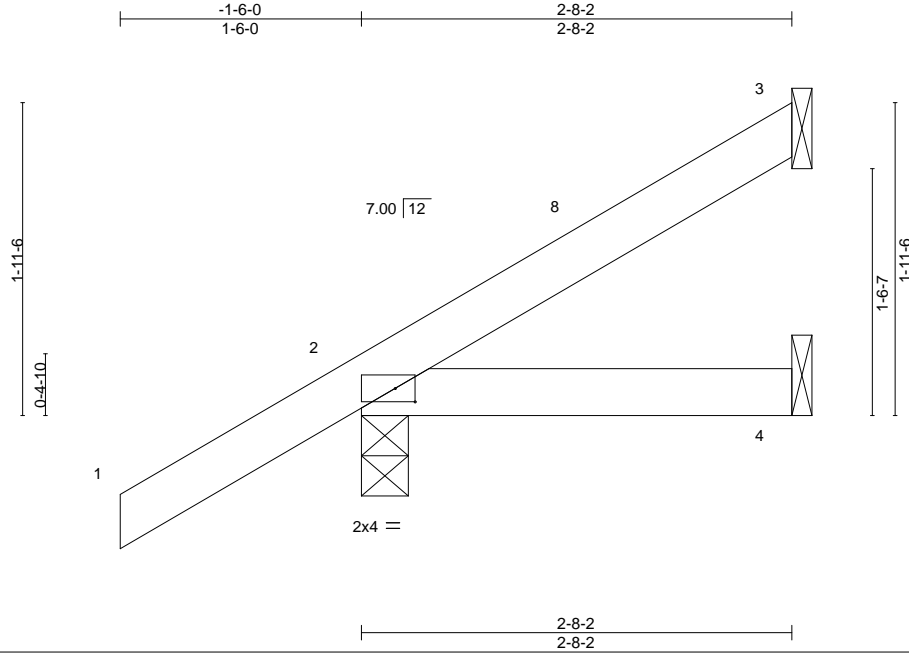

Plate Offsets (X,Y)-- [2:0-1-8,0-1-0]

LOADING (psf)	SPACING-	2-0-0	CSI.	DEFL.	in (loc)	l/defl	L/d	PLATES	GRIP
TCLL 20.0	Plate Grip DOL	1.25	TC 0.14	Vert(LL)	-0.00	4-7	>999	MT20	244/190
TCDL 7.0	Lumber DOL	1.25	BC 0.06	Vert(CT)	-0.00	4-7	>999		
BCLL 0.0 *	Rep Stress Incr	YES	WB 0.00	Horz(CT)	0.00	3	n/a		
BCDL 10.0	Code	FBC2020/TPI2014	Matrix-MP					Weight: 11 lb	FT = 20%

LUMBER-

TOP CHORD 2x4 SP No.2
BOT CHORD 2x4 SP No.2

BRACING-

TOP CHORD Structural wood sheathing directly applied or 2-8-2 oc purlins.
BOT CHORD Rigid ceiling directly applied or 10-0-0 oc bracing.

REACTIONS.

(size) 3=Mechanical, 2=0-3-8, 4=Mechanical
Max Horz 2=78(LC 12)
Max Uplift 3=-33(LC 12), 2=-54(LC 12)
Max Grav 3=54(LC 19), 2=201(LC 1), 4=44(LC 3)

FORCES. (lb) - Max. Comp./Max. Ten. - All forces 250 (lb) or less except when shown.

NOTES-

- 1) Wind: ASCE 7-16; Vult=130mph (3-second gust) Vasd=101mph; TCDL=4.2psf; BCDL=3.0psf; h=20ft; Cat. II; Exp B; Encl., GCpi=0.18; MWFRS (envelope) gable end zone and C-C Exterior(2E) -1-6-0 to 1-6-0, Interior(1) 1-6-0 to 2-7-6 zone;C-C for members and forces & MWFRS for reactions shown; Lumber DOL=1.60 plate grip DOL=1.60
- 2) Building Designer / Project engineer responsible for verifying applied roof live load shown covers rain loading requirements specific to the use of this truss component.
- 3) This truss has been designed for a 10.0 psf bottom chord live load nonconcurrent with any other live loads.
- 4) * This truss has been designed for a live load of 20.0psf on the bottom chord in all areas where a rectangle 3-6-0 tall by 2-0-0 wide will fit between the bottom chord and any other members.
- 5) Refer to girder(s) for truss to truss connections.
- 6) Provide mechanical connection (by others) of truss to bearing plate capable of withstanding 33 lb uplift at joint 3 and 54 lb uplift at joint 2.



Philip J. O'Regan PE No.58126
MiTek USA, Inc. FL Cert 6634
6904 Parke East Blvd. Tampa FL 33610
Date:

September 7,2021

WARNING - Verify design parameters and READ NOTES ON THIS AND INCLUDED MITEK REFERENCE PAGE MII-7473 rev. 5/19/2020 BEFORE USE.

Design valid for use only with MiTek® connectors. This design is based only upon parameters shown, and is for an individual building component, not a truss system. Before use, the building designer must verify the applicability of design parameters and properly incorporate this design into the overall building design. Bracing indicated is to prevent buckling of individual truss web and/or chord members only. Additional temporary and permanent bracing is always required for stability and to prevent collapse with possible personal injury and property damage. For general guidance regarding the fabrication, storage, delivery, erection and bracing of trusses and truss systems, see

ANSI/TPI1 Quality Criteria, DSB-89 and BCSI Building Component

Safety Information available from Truss Plate Institute, 2670 Crain Highway, Suite 203 Waldorf, MD 20601



6904 Parke East Blvd.
Tampa, FL 36610

Job	Truss	Truss Type	Qty	Ply	IC CONST. - LIBERTY RES.	T25256406
2918935	CJ03B	Jack-Open	1	1		

Builders FirstSource (Lake City,FL), Lake City, FL - 32055, 8.430 s Aug 16 2021 MiTek Industries, Inc. Sat Sep 4 11:23:16 2021 Page 1
 ID:b2ldskJGjOxOjHJDJPp?LTyh2aU-NLK5O7WuEQA9eiqrJEhe9XokGxCLpykeqfBO2lyh129



Scale = 1:18.8

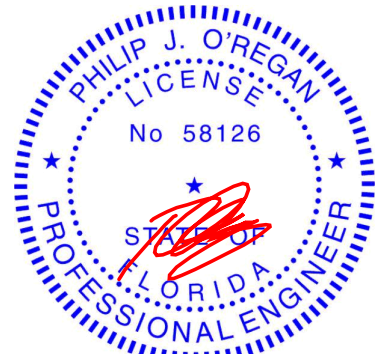
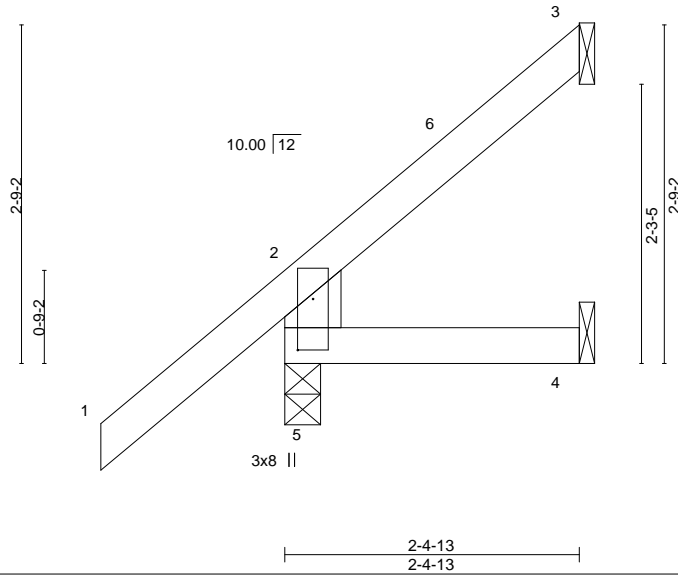

Philip J. O'Regan PE No.58126
 MiTek USA, Inc. FL Cert 6634
 6904 Parke East Blvd. Tampa FL 33610
 Date:

Plate Offsets (X,Y)-- [5:0-5-0,0-1-8]

LOADING (psf)	SPACING-	CSI.	DEFL.	in (loc)	l/defl	L/d	PLATES	GRIP
TCLL 20.0	2-0-0	TC 0.31	Vert(LL)	0.00 4-5	>999	240	MT20	244/190
TCDL 7.0	Plate Grip DOL 1.25	BC 0.06	Vert(CT)	-0.00 4-5	>999	180		
BCLL 0.0 *	Lumber DOL 1.25	WB 0.00	Horz(CT)	0.00 3	n/a	n/a		
BCDL 10.0	Rep Stress Incr YES	Matrix-MR						
	Code FBC2020/TPI2014						Weight: 13 lb	FT = 20%

LUMBER-

TOP CHORD 2x4 SP No.2
 BOT CHORD 2x4 SP No.2
 WEBS 2x6 SP No.2

BRACING-

TOP CHORD Structural wood sheathing directly applied or 2-4-13 oc purlins, except end verticals.
 BOT CHORD Rigid ceiling directly applied or 10-0-0 oc bracing.

REACTIONS.

(size) 5=0-3-8, 3=Mechanical, 4=Mechanical
 Max Horz 5=96(LC 12)
 Max Uplift 5=-33(LC 12), 3=-44(LC 12), 4=-2(LC 12)
 Max Grav 5=210(LC 1), 3=42(LC 19), 4=35(LC 3)

FORCES. (lb) - Max. Comp./Max. Ten. - All forces 250 (lb) or less except when shown.

NOTES-

- 1) Wind: ASCE 7-16; Vult=130mph (3-second gust) Vasd=101mph; TCDL=4.2psf; BCDL=3.0psf; h=20ft; Cat. II; Exp B; Encl., GCpi=0.18; MWFRS (envelope) gable end zone and C-C Exterior(2E) -1-6-0 to 1-6-0, Interior(1) 1-6-0 to 2-4-1 zone; end vertical left exposed; C-C for members and forces & MWFRS for reactions shown; Lumber DOL=1.60 plate grip DOL=1.60
- 2) Building Designer / Project engineer responsible for verifying applied roof live load shown covers rain loading requirements specific to the use of this truss component.
- 3) This truss has been designed for a 10.0 psf bottom chord live load nonconcurrent with any other live loads.
- 4) * This truss has been designed for a live load of 20.0psf on the bottom chord in all areas where a rectangle 3-6-0 tall by 2-0-0 wide will fit between the bottom chord and any other members.
- 5) Refer to girder(s) for truss to truss connections.
- 6) Provide mechanical connection (by others) of truss to bearing plate capable of withstanding 33 lb uplift at joint 5, 44 lb uplift at joint 3 and 2 lb uplift at joint 4.

September 7, 2021

WARNING - Verify design parameters and READ NOTES ON THIS AND INCLUDED MITEK REFERENCE PAGE MII-7473 rev. 5/19/2020 BEFORE USE.

Design valid for use only with MiTek® connectors. This design is based only upon parameters shown, and is for an individual building component, not a truss system. Before use, the building designer must verify the applicability of design parameters and properly incorporate this design into the overall building design. Bracing indicated is to prevent buckling of individual truss web and/or chord members only. Additional temporary and permanent bracing is always required for stability and to prevent collapse with possible personal injury and property damage. For general guidance regarding the fabrication, storage, delivery, erection and bracing of trusses and truss systems, see

ANSI/TPI1 Quality Criteria, DSB-89 and BCSI Building Component

Safety Information available from Truss Plate Institute, 2670 Crain Highway, Suite 203 Waldorf, MD 20601



6904 Parke East Blvd.
 Tampa, FL 36610

Job	Truss	Truss Type	Qty	Ply	IC CONST. - LIBERTY RES.	T25256407
2918935	CJ03C	Jack-Open	1	1	Job Reference (optional)	

Builders FirstSource (Lake City,FL),

Lake City, FL - 32055,

8.430 s Aug 16 2021 MiTek Industries, Inc. Sat Sep 4 11:23:17 2021 Page 1
ID:b2ldsKJGjOxOjHDJPp?LTyh2aU-rYITbTWW?kJOGsP1tyCtikLxaLXrYP_n3Jwyakyh128

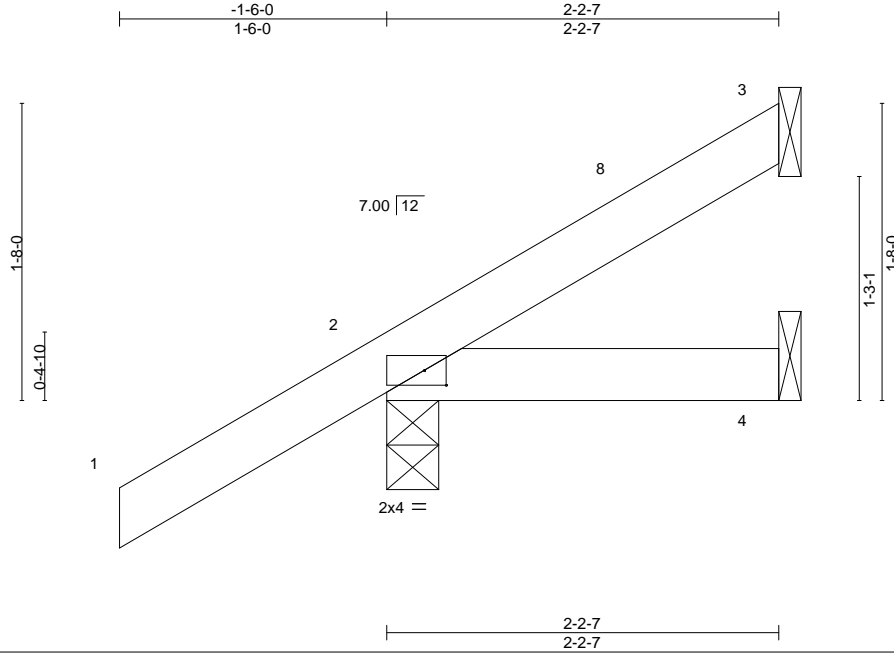

Scale = 1:12.9

Plate Offsets (X,Y)-- [2:0-1-8,0-1-0]

LOADING (psf)	SPACING-	2-0-0	CSI.	DEFL.	in (loc)	l/defl	L/d	PLATES	GRIP
TCLL 20.0	Plate Grip DOL	1.25	TC 0.14	Vert(LL)	-0.00	7	>999	MT20	244/190
TCDL 7.0	Lumber DOL	1.25	BC 0.04	Vert(CT)	-0.00	7	>999		
BCLL 0.0 *	Rep Stress Incr	YES	WB 0.00	Horz(CT)	0.00	3	n/a		
BCDL 10.0	Code	FBC2020/TPI2014	Matrix-MP					Weight: 10 lb	FT = 20%

LUMBER-

TOP CHORD 2x4 SP No.2
BOT CHORD 2x4 SP No.2

BRACING-

TOP CHORD Structural wood sheathing directly applied or 2-2-7 oc purlins.
BOT CHORD Rigid ceiling directly applied or 10-0-0 oc bracing.

REACTIONS.

(size) 3=Mechanical, 2=0-3-8, 4=Mechanical
Max Horz 2=69(LC 12)
Max Uplift 3=-25(LC 12), 2=-55(LC 12)
Max Grav 3=40(LC 19), 2=189(LC 1), 4=34(LC 3)

FORCES. (lb) - Max. Comp./Max. Ten. - All forces 250 (lb) or less except when shown.

NOTES-

- 1) Wind: ASCE 7-16; Vult=130mph (3-second gust) Vasd=101mph; TCDL=4.2psf; BCDL=3.0psf; h=20ft; Cat. II; Exp B; Encl., GCpi=0.18; MWFRS (envelope) gable end zone and C-C Exterior(2E) -1-6-0 to 1-6-0, Interior(1) 1-6-0 to 2-1-11 zone;C-C for members and forces & MWFRS for reactions shown; Lumber DOL=1.60 plate grip DOL=1.60
- 2) Building Designer / Project engineer responsible for verifying applied roof live load shown covers rain loading requirements specific to the use of this truss component.
- 3) This truss has been designed for a 10.0 psf bottom chord live load nonconcurrent with any other live loads.
- 4) * This truss has been designed for a live load of 20.0psf on the bottom chord in all areas where a rectangle 3-6-0 tall by 2-0-0 wide will fit between the bottom chord and any other members.
- 5) Refer to girder(s) for truss to truss connections.
- 6) Provide mechanical connection (by others) of truss to bearing plate capable of withstanding 25 lb uplift at joint 3 and 55 lb uplift at joint 2.

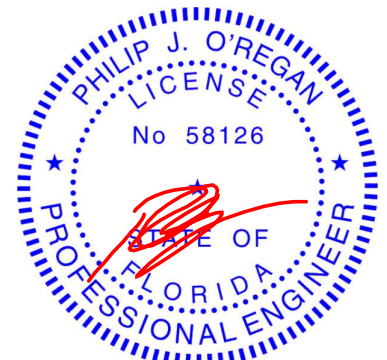

Philip J. O'Regan PE No.58126
MiTek USA, Inc. FL Cert 6634
6904 Parke East Blvd. Tampa FL 33610
Date:

September 7,2021

WARNING - Verify design parameters and READ NOTES ON THIS AND INCLUDED MITEK REFERENCE PAGE MII-7473 rev. 5/19/2020 BEFORE USE.

Design valid for use only with MiTek® connectors. This design is based only upon parameters shown, and is for an individual building component, not a truss system. Before use, the building designer must verify the applicability of design parameters and properly incorporate this design into the overall building design. Bracing indicated is to prevent buckling of individual truss web and/or chord members only. Additional temporary and permanent bracing is always required for stability and to prevent collapse with possible personal injury and property damage. For general guidance regarding the fabrication, storage, delivery, erection and bracing of trusses and truss systems, see

ANSI/TPI1 Quality Criteria, DSB-89 and BCSI Building Component

Safety Information available from Truss Plate Institute, 2670 Crain Highway, Suite 203 Waldorf, MD 20601



6904 Parke East Blvd.
Tampa, FL 36610

Job	Truss	Truss Type	Qty	Ply	IC CONST. - LIBERTY RES.	T25256408
2918935	CJ05	Jack-Open	2	1	Job Reference (optional)	

Builders FirstSource (Lake City,FL), Lake City, FL - 32055, 8.430 s Aug 16 2021 MiTek Industries, Inc. Sat Sep 4 11:23:18 2021 Page 1
 ID:b2ldskJGjOxOjHDJPP?LTyh2aU-JkssppX9m2Rtu0_ERfj6Eyt4AlqnHsEwHzgV6Byh127

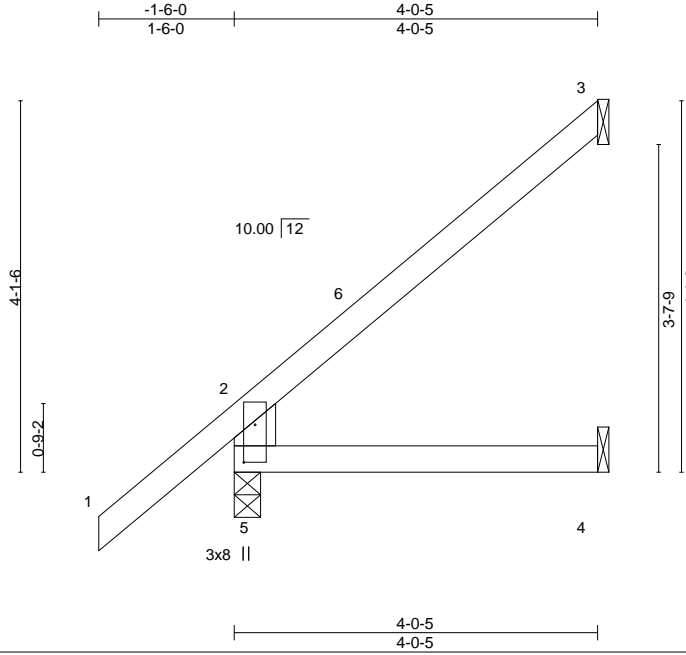

Scale = 1:25.5

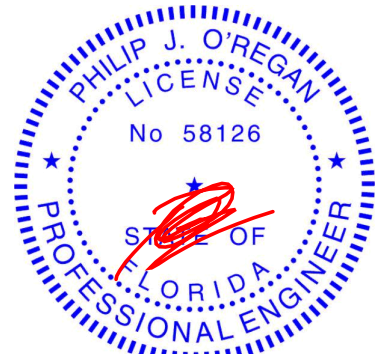

Philip J. O'Regan PE No.58126
 MiTek USA, Inc. FL Cert 6634
 6904 Parke East Blvd. Tampa FL 33610
 Date:

Plate Offsets (X,Y)-- [5:0-5-0,0-1-8]

LOADING (psf)	SPACING-	2-0-0	CSI.	DEFL.	in (loc)	l/defl	L/d	PLATES	GRIP
TCLL 20.0	Plate Grip DOL	1.25	TC 0.28	Vert(LL)	0.02 4-5	>999	240	MT20	244/190
TCDL 7.0	Lumber DOL	1.25	BC 0.26	Vert(CT)	-0.02 4-5	>999	180		
BCLL 0.0 *	Rep Stress Incr	YES	WB 0.00	Horz(CT)	-0.02 3	n/a	n/a		
BCDL 10.0	Code	FBC2020/TPI2014	Matrix-MR					Weight: 18 lb	FT = 20%

LUMBER-

TOP CHORD 2x4 SP No.2
 BOT CHORD 2x4 SP No.2
 WEBS 2x6 SP No.2

BRACING-

TOP CHORD Structural wood sheathing directly applied or 4-0-5 oc purlins, except end verticals.
 BOT CHORD Rigid ceiling directly applied or 10-0-0 oc bracing.

REACTIONS.

(size) 5=0-3-8, 3=Mechanical, 4=Mechanical
 Max Horz 5=142(LC 12)
 Max Uplift 5=-22(LC 12), 3=-82(LC 12), 4=-7(LC 12)
 Max Grav 5=253(LC 1), 3=94(LC 19), 4=67(LC 3)

FORCES. (lb) - Max. Comp./Max. Ten. - All forces 250 (lb) or less except when shown.

NOTES-

- 1) Wind: ASCE 7-16; Vult=130mph (3-second gust) Vasd=101mph; TCDL=4.2psf; BCDL=3.0psf; h=20ft; Cat. II; Exp B; Encl., GCpi=0.18; MWFRS (envelope) gable end zone and C-C Exterior(2E) -1-6-0 to 1-6-0, Interior(1) 1-6-0 to 3-11-9 zone; end vertical left exposed;C-C for members and forces & MWFRS for reactions shown; Lumber DOL=1.60 plate grip DOL=1.60
- 2) Building Designer / Project engineer responsible for verifying applied roof live load shown covers rain loading requirements specific to the use of this truss component.
- 3) This truss has been designed for a 10.0 psf bottom chord live load nonconcurrent with any other live loads.
- 4) * This truss has been designed for a live load of 20.0psf on the bottom chord in all areas where a rectangle 3-6-0 tall by 2-0-0 wide will fit between the bottom chord and any other members.
- 5) Refer to girder(s) for truss to truss connections.
- 6) Provide mechanical connection (by others) of truss to bearing plate capable of withstanding 22 lb uplift at joint 5, 82 lb uplift at joint 3 and 7 lb uplift at joint 4.

September 7,2021

WARNING - Verify design parameters and READ NOTES ON THIS AND INCLUDED MITEK REFERENCE PAGE MII-7473 rev. 5/19/2020 BEFORE USE.

Design valid for use only with MiTek® connectors. This design is based only upon parameters shown, and is for an individual building component, not a truss system. Before use, the building designer must verify the applicability of design parameters and properly incorporate this design into the overall building design. Bracing indicated is to prevent buckling of individual truss web and/or chord members only. Additional temporary and permanent bracing is always required for stability and to prevent collapse with possible personal injury and property damage. For general guidance regarding the fabrication, storage, delivery, erection and bracing of trusses and truss systems, see

ANSI/TPI1 Quality Criteria, DSB-89 and BCSI Building Component

Safety Information available from Truss Plate Institute, 2670 Crain Highway, Suite 203 Waldorf, MD 20601



6904 Parke East Blvd.
 Tampa, FL 36610

Job 2918935	Truss CJ05A	Truss Type Jack-Open	Qty 2	Ply 1	IC CONST. - LIBERTY RES. Job Reference (optional)	T25256409
----------------	----------------	-------------------------	----------	----------	--	-----------

Builders FirstSource (Lake City,FL),

Lake City, FL - 32055,

8.430 s Aug 16 2021 MiTek Industries, Inc. Sat Sep 4 11:23:18 2021 Page 1
ID:b2ldskJGjOxOjHDJPP?LTyh2aU-JksspX9m2Rtu0_ERfj6Eyt2SlpsHsEwHzgV6Byh127

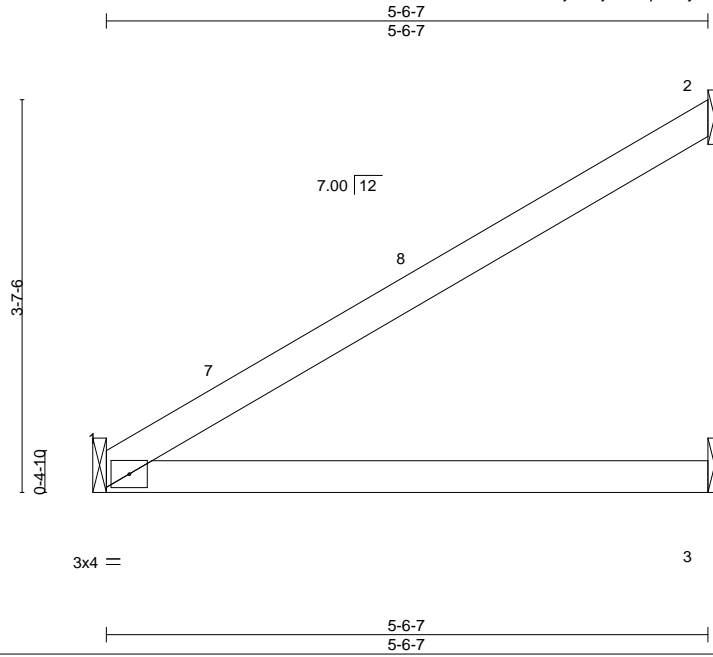

Scale = 1:21.2

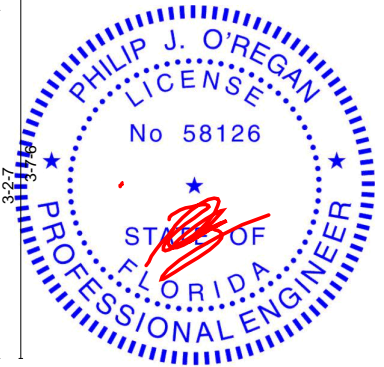

Philip J. O'Regan PE No.58126
MiTek USA, Inc. FL Cert 6634
6904 Parke East Blvd. Tampa FL 33610
Date:

LOADING (psf)	SPACING-	CSI.	DEFL.	in	(loc)	l/defl	L/d	PLATES	GRIP
TCLL 20.0	Plate Grip DOL 1.25	TC 0.39	Vert(LL)	0.05	3-6	>999	240	MT20	244/190
TCDL 7.0	Lumber DOL 1.25	BC 0.31	Vert(CT)	-0.09	3-6	>717	180		
BCLL 0.0 *	Rep Stress Incr YES	WB 0.00	Horz(CT)	0.00	1	n/a	n/a		
BCDL 10.0	Code FBC2020/TPI2014	Matrix-MP						Weight: 18 lb	FT = 20%

LUMBER-

TOP CHORD 2x4 SP No.2
BOT CHORD 2x4 SP No.2

BRACING-

TOP CHORD Structural wood sheathing directly applied or 5-6-7 oc purlins.
BOT CHORD Rigid ceiling directly applied or 10-0-0 oc bracing.

REACTIONS.

(size) 1=Mechanical, 2=Mechanical, 3=Mechanical
Max Horz 1=110(LC 12)
Max Uplift 1=-21(LC 12), 2=-85(LC 12), 3=-3(LC 12)
Max Grav 1=202(LC 1), 2=137(LC 19), 3=100(LC 3)

FORCES. (lb) - Max. Comp./Max. Ten. - All forces 250 (lb) or less except when shown.

NOTES-

- 1) Wind: ASCE 7-16; Vult=130mph (3-second gust) Vasd=101mph; TCDL=4.2psf; BCDL=3.0psf; h=20ft; Cat. II; Exp B; Encl., GCpi=0.18; MWFRS (envelope) gable end zone and C-C Exterior(2E) 0-0-0 to 3-0-0, Interior(1) 3-0-0 to 5-5-11 zone; C-C for members and forces & MWFRS for reactions shown; Lumber DOL=1.60 plate grip DOL=1.60
- 2) Building Designer / Project engineer responsible for verifying applied roof live load shown covers rain loading requirements specific to the use of this truss component.
- 3) This truss has been designed for a 10.0 psf bottom chord live load nonconcurrent with any other live loads.
- 4) * This truss has been designed for a live load of 20.0psf on the bottom chord in all areas where a rectangle 3-6-0 tall by 2-0-0 wide will fit between the bottom chord and any other members.
- 5) Refer to girder(s) for truss to truss connections.
- 6) Provide mechanical connection (by others) of truss to bearing plate capable of withstanding 21 lb uplift at joint 1, 85 lb uplift at joint 2 and 3 lb uplift at joint 3.

September 7,2021

WARNING - Verify design parameters and READ NOTES ON THIS AND INCLUDED MITEK REFERENCE PAGE MII-7473 rev. 5/19/2020 BEFORE USE.

Design valid for use only with MiTek® connectors. This design is based only upon parameters shown, and is for an individual building component, not a truss system. Before use, the building designer must verify the applicability of design parameters and properly incorporate this design into the overall building design. Bracing indicated is to prevent buckling of individual truss web and/or chord members only. Additional temporary and permanent bracing is always required for stability and to prevent collapse with possible personal injury and property damage. For general guidance regarding the fabrication, storage, delivery, erection and bracing of trusses and truss systems, see

ANSI/TPI1 Quality Criteria, DSB-89 and BCSI Building Component

Safety Information available from Truss Plate Institute, 2670 Crain Highway, Suite 203 Waldorf, MD 20601



6904 Parke East Blvd.
Tampa, FL 36610

Job 2918935	Truss EJ01	Truss Type Jack-Open	Qty 6	Ply 1	IC CONST. - LIBERTY RES. Job Reference (optional)	T25256410
----------------	---------------	-------------------------	----------	----------	--	-----------

Builders FirstSource (Lake City,FL),

Lake City, FL - 32055,

8.430 s Aug 16 2021 MiTek Industries, Inc. Sat Sep 4 11:23:19 2021 Page 1

ID:b2ldskJGjOxOjHDJPP?LTyh2aU-nwQE08YnXLZkV9ZQ?NELn9QB086y0JT4WdP2fdyh126



Scale = 1:31.6

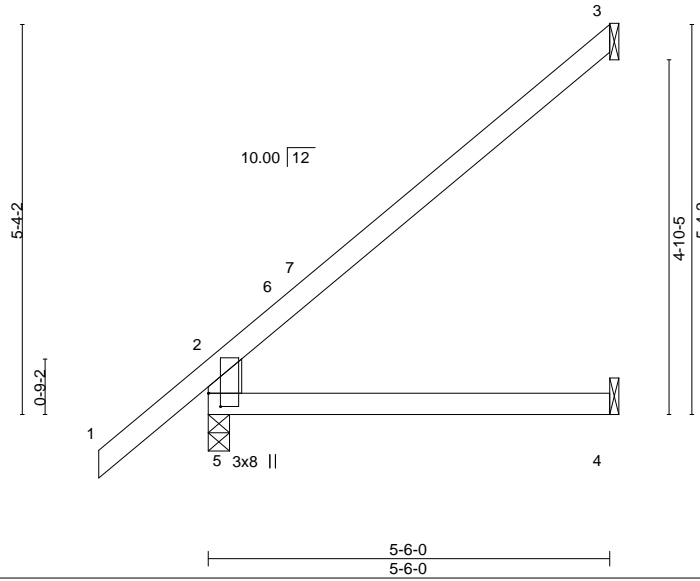

Philip J. O'Regan PE No.58126
MiTek USA, Inc. FL Cert 6634
6904 Parke East Blvd. Tampa FL 33610
Date:

Plate Offsets (X,Y)-- [5:0-2-3,0-2-0]

LOADING (psf)	SPACING-		CSI.	DEFL.	in	(loc)	l/defl	L/d	PLATES	GRIP
TCLL 20.0	Plate Grip DOL 1.25	2-0-0	TC 0.55	Vert(LL) 0.06	4-5	>968	240		MT20	244/190
TCDL 7.0	Lumber DOL 1.25		BC 0.45	Vert(CT) -0.07	4-5	>870	180			
BCLL 0.0 *	Rep Stress Incr YES		WB 0.00	Horz(CT) -0.04	3	n/a	n/a			
BCDL 10.0	Code FBC2020/TPI2014		Matrix-MR						Weight: 23 lb	FT = 20%

LUMBER-

TOP CHORD 2x4 SP No.2
BOT CHORD 2x4 SP No.2
WEBS 2x6 SP No.2

BRACING-

TOP CHORD Structural wood sheathing directly applied or 5-6-0 oc purlins, except end verticals.
BOT CHORD Rigid ceiling directly applied or 10-0-0 oc bracing.

REACTIONS.

(size) 5=0-3-8, 3=Mechanical, 4=Mechanical
Max Horz 5=185(LC 12)
Max Uplift 5=-16(LC 12), 3=-115(LC 12), 4=-10(LC 12)
Max Grav 5=302(LC 1), 3=136(LC 19), 4=96(LC 3)

FORCES. (lb) - Max. Comp./Max. Ten. - All forces 250 (lb) or less except when shown.

TOP CHORD 2-5=-255/150

NOTES-

- 1) Wind: ASCE 7-16; Vult=130mph (3-second gust) Vasd=101mph; TCDL=4.2psf; BCDL=3.0psf; h=20ft; Cat. II; Exp B; Encl., GCpi=0.18; MWFRS (envelope) gable end zone and C-C Exterior(2E) -1-6-0 to 1-6-0, Interior(1) 1-6-0 to 5-5-4 zone; end vertical left exposed; C-C for members and forces & MWFRS for reactions shown; Lumber DOL=1.60 plate grip DOL=1.60
- 2) Building Designer / Project engineer responsible for verifying applied roof live load shown covers rain loading requirements specific to the use of this truss component.
- 3) This truss has been designed for a 10.0 psf bottom chord live load nonconcurrent with any other live loads.
- 4) * This truss has been designed for a live load of 20.0psf on the bottom chord in all areas where a rectangle 3-6-0 tall by 2-0-0 wide will fit between the bottom chord and any other members.
- 5) Refer to girder(s) for truss to truss connections.
- 6) Provide mechanical connection (by others) of truss to bearing plate capable of withstanding 16 lb uplift at joint 5, 115 lb uplift at joint 3 and 10 lb uplift at joint 4.

September 7,2021

WARNING - Verify design parameters and READ NOTES ON THIS AND INCLUDED MITEK REFERENCE PAGE MII-7473 rev. 5/19/2020 BEFORE USE.

Design valid for use only with MiTek® connectors. This design is based only upon parameters shown, and is for an individual building component, not a truss system. Before use, the building designer must verify the applicability of design parameters and properly incorporate this design into the overall building design. Bracing indicated is to prevent buckling of individual truss web and/or chord members only. Additional temporary and permanent bracing is always required for stability and to prevent collapse with possible personal injury and property damage. For general guidance regarding the fabrication, storage, delivery, erection and bracing of trusses and truss systems, see

ANSI/TPI1 Quality Criteria, DSB-89 and BCSI Building Component

Safety Information available from Truss Plate Institute, 2670 Crain Highway, Suite 203 Waldorf, MD 20601



6904 Parke East Blvd.
Tampa, FL 36610

Job	Truss	Truss Type	Qty	Ply	IC CONST. - LIBERTY RES.	T25256411
2918935	EJ02	Jack-Open Girder	1	1	Job Reference (optional)	

Builders FirstSource (Lake City,FL), Lake City, FL - 32055,

8.430 s Aug 16 2021 MiTek Industries, Inc. Sat Sep 4 11:23:20 2021 Page 1
ID:b2ldskJGjOxOjHDJPP?LTyh2aU-G7_cDUZPIfthb7J7cY4laJNzTnYXjll2DIH9cB3yh125

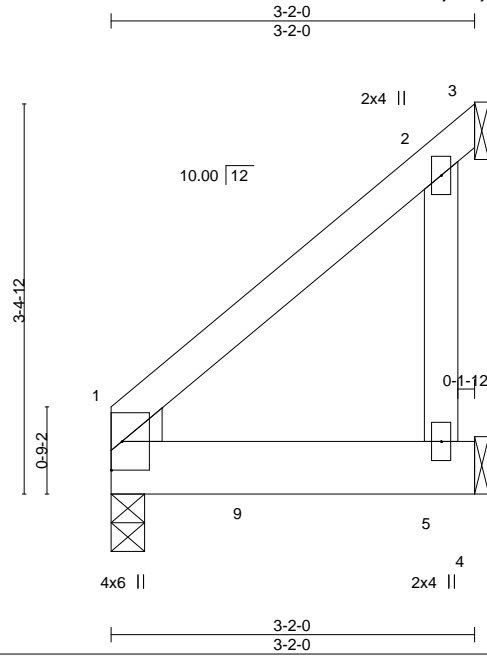

Scale = 1:20.1

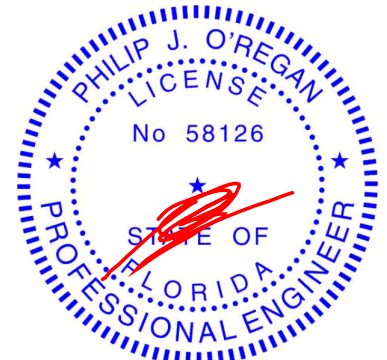

Philip J. O'Regan PE No.58126
MiTek USA, Inc. FL Cert 6634
6904 Parke East Blvd. Tampa FL 33610
Date:

LOADING (psf)	SPACING-	CSI.	DEFL.	in (loc)	l/defl	L/d	PLATES	GRIP
TCLL 20.0	2-0-0 Plate Grip DOL 1.25	TC 0.08	Vert(LL) -0.00	5-8	>999	240	MT20	244/190
TCDL 7.0	Lumber DOL 1.25	BC 0.16	Vert(CT) -0.01	5-8	>999/a	180		
BCLL 0.0 *	Rep Stress Incr NO	WB 0.04	Horz(CT) 0.00	1	n/a	n/a		
BCDL 10.0	Code FBC2020/TPI2014	Matrix-MP					Weight: 18 lb	FT = 20%

LUMBER-

TOP CHORD 2x4 SP No.2
BOT CHORD 2x6 SP No.2
WEBS 2x4 SP No.3
WEDGE
Left: 2x4 SP No.3

BRACING-

TOP CHORD Structural wood sheathing directly applied or 3-2-0 oc purlins.
BOT CHORD Rigid ceiling directly applied or 10-0-0 oc bracing.

REACTIONS.

(size) 3=Mechanical, 1=0-3-8, 5=Mechanical
Max Horz 1=89(LC 8)
Max Uplift 3=114(LC 29), 5=174(LC 8)
Max Grav 3=73(LC 8), 1=201(LC 1), 5=325(LC 29)

FORCES. (lb) - Max. Comp./Max. Ten. - All forces 250 (lb) or less except when shown.

NOTES-

- 1) Wind: ASCE 7-16; Vult=130mph (3-second gust) Vasd=101mph; TCDL=4.2psf; BCDL=3.0psf; h=20ft; Cat. II; Exp B; Encl., GCpi=0.18; MWFRS (envelope) gable end zone; Lumber DOL=1.60 plate grip DOL=1.60
- 2) Building Designer / Project engineer responsible for verifying applied roof live load shown covers rain loading requirements specific to the use of this truss component.
- 3) This truss has been designed for a 10.0 psf bottom chord live load nonconcurrent with any other live loads.
- 4) * This truss has been designed for a live load of 20.0psf on the bottom chord in all areas where a rectangle 3-6-0 tall by 2-0-0 wide will fit between the bottom chord and any other members.
- 5) Refer to girder(s) for truss to truss connections.
- 6) Provide mechanical connection (by others) of truss to bearing plate capable of withstanding 114 lb uplift at joint 3 and 174 lb uplift at joint 5.
- 7) Hanger(s) or other connection device(s) shall be provided sufficient to support concentrated load(s) 182 lb down and 41 lb up at 1-2-12 on bottom chord. The design/selection of such connection device(s) is the responsibility of others.
- 8) In the LOAD CASE(S) section, loads applied to the face of the truss are noted as front (F) or back (B).

LOAD CASE(S) Standard

- 1) Dead + Roof Live (balanced): Lumber Increase=1.25, Plate Increase=1.25
Uniform Loads (plf)
Vert: 1-3=-54, 4-6=-20
Concentrated Loads (lb)
Vert: 9=-182(B)

September 7, 2021

WARNING - Verify design parameters and READ NOTES ON THIS AND INCLUDED MITEK REFERENCE PAGE MII-7473 rev. 5/19/2020 BEFORE USE.

Design valid for use only with MiTek® connectors. This design is based only upon parameters shown, and is for an individual building component, not a truss system. Before use, the building designer must verify the applicability of design parameters and properly incorporate this design into the overall building design. Bracing indicated is to prevent buckling of individual truss web and/or chord members only. Additional temporary and permanent bracing is always required for stability and to prevent collapse with possible personal injury and property damage. For general guidance regarding the fabrication, storage, delivery, erection and bracing of trusses and truss systems, see

ANSI/TPI1 Quality Criteria, DSB-89 and BCSI Building Component

Safety Information available from Truss Plate Institute, 2670 Crain Highway, Suite 203 Waldorf, MD 20601



6904 Parke East Blvd.
Tampa, FL 36610

Job	Truss	Truss Type	Qty	Ply	IC CONST. - LIBERTY RES.	T25256412
2918935	EJ03	Jack-Open	2	1	Job Reference (optional)	

Builders FirstSource (Lake City,FL),

Lake City, FL - 32055,

8.430 s Aug 16 2021 MiTek Industries, Inc. Sat Sep 4 11:23:21 2021 Page 1

ID:b2ldskJJGjOxOjHDJPP?LTyh2aU-kjY_RqZ13zpSITio6nGpsaVaiyoGUCzN_xu9jWyh124

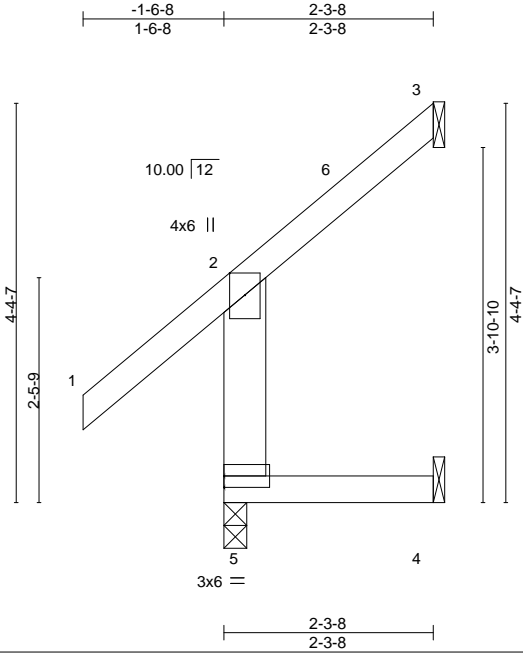

LOADING (psf)	SPACING-	CSI.	DEFL.	in (loc)	l/defl	L/d	PLATES	GRIP
TCLL 20.0	2-0-0 Plate Grip DOL 1.25	TC 0.33	Vert(LL) 0.01	4-5	>999	240	MT20	244/190
TCDL 7.0	Lumber DOL 1.25	BC 0.46	Vert(CT) 0.01	4-5	>999	180		
BCLL 0.0 *	Rep Stress Incr YES	WB 0.00	Horz(CT) -0.08	3	n/a	n/a		
BCDL 10.0	Code FBC2020/TPI2014	Matrix-MR					Weight: 16 lb	FT = 20%

LUMBER-	BRACING-
TOP CHORD 2x4 SP No.2	TOP CHORD Structural wood sheathing directly applied or 2-3-8 oc purlins, except end verticals.
BOT CHORD 2x4 SP No.2	BOT CHORD Rigid ceiling directly applied or 10-0-0 oc bracing.
WEBS 2x6 SP No.2	

REACTIONS. (size) 5=0-3-0, 3=Mechanical, 4=Mechanical
 Max Horz 5=96(LC 9)
 Max Uplift 3=-71(LC 12), 4=-41(LC 12)
 Max Grav 5=212(LC 1), 3=53(LC 19), 4=53(LC 10)

FORCES. (lb) - Max. Comp./Max. Ten. - All forces 250 (lb) or less except when shown.

- NOTES-**
- 1) Wind: ASCE 7-16; Vult=130mph (3-second gust) Vasd=101mph; TCDL=4.2psf; BCDL=3.0psf; h=20ft; Cat. II; Exp B; Encl., GCpi=0.18; MWFRS (envelope) gable end zone and C-C Exterior(2E) -1-6-8 to 1-5-8, Interior(1) 1-5-8 to 2-2-12 zone; end vertical left exposed; C-C for members and forces & MWFRS for reactions shown; Lumber DOL=1.60 plate grip DOL=1.60
 - 2) Building Designer / Project engineer responsible for verifying applied roof live load shown covers rain loading requirements specific to the use of this truss component.
 - 3) This truss has been designed for a 10.0 psf bottom chord live load nonconcurrent with any other live loads.
 - 4) * This truss has been designed for a live load of 20.0psf on the bottom chord in all areas where a rectangle 3-6-0 tall by 2-0-0 wide will fit between the bottom chord and any other members.
 - 5) Refer to girder(s) for truss to truss connections.
 - 6) Provide mechanical connection (by others) of truss to bearing plate capable of withstanding 71 lb uplift at joint 3 and 41 lb uplift at joint 4.

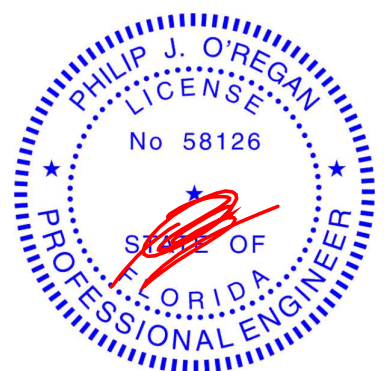

Philip J. O'Regan PE No.58126
 MiTek USA, Inc. FL Cert 6634
 6904 Parke East Blvd. Tampa FL 33610
 Date: September 7, 2021

Job	Truss	Truss Type	Qty	Ply	IC CONST. - LIBERTY RES.	T25256413
2918935	EJ04	Jack-Open	3	1	Job Reference (optional)	

Builders FirstSource (Lake City,FL), Lake City, FL - 32055,

8.430 s Aug 16 2021 MiTek Industries, Inc. Sat Sep 4 11:23:22 2021 Page 1

ID:b2ldskJGjOxOjHDJpP?LTyh2aU-CV5MeAafqGxJMdH?gVo2Po2IBMBYDfDWcbeifFyyh123

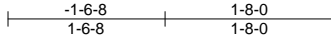

Scale = 1:22.6

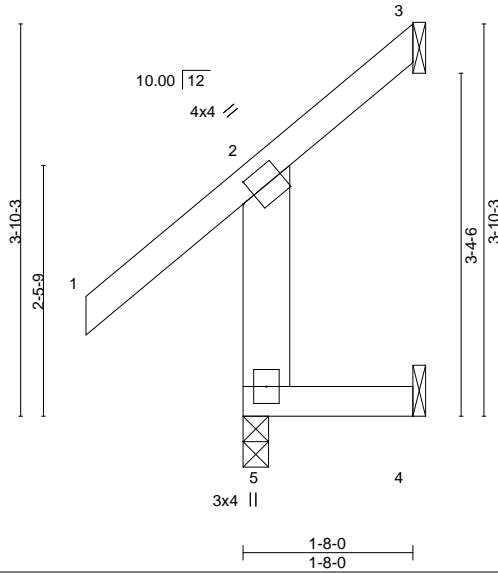

Plate Offsets (X,Y)-- [2:0-1-11,0-2-0]

LOADING (psf)	SPACING-	2-0-0	CSI.	DEFL.	in	(loc)	l/defl	L/d	PLATES	GRIP
TCLL 20.0	Plate Grip DOL	1.25	TC 0.34	Vert(LL)	-0.00	4-5	>999	240	MT20	244/190
TCDL 7.0	Lumber DOL	1.25	BC 0.27	Vert(CT)	-0.00	4-5	>999	180		
BCLL 0.0 *	Rep Stress Incr	YES	WB 0.00	Horz(CT)	-0.03	3	n/a	n/a		
BCDL 10.0	Code	FBC2020/TPI2014	Matrix-MR						Weight: 14 lb	FT = 20%

LUMBER-

TOP CHORD 2x4 SP No.2
 BOT CHORD 2x4 SP No.2
 WEBS 2x6 SP No.2

BRACING-

TOP CHORD Structural wood sheathing directly applied or 1-8-0 oc purlins, except end verticals.
 BOT CHORD Rigid ceiling directly applied or 10-0-0 oc bracing.

REACTIONS.

(size) 5=0-3-0, 3=Mechanical, 4=Mechanical
 Max Horz 5=87(LC 9)
 Max Uplift 5=-7(LC 8), 3=-57(LC 12), 4=-51(LC 9)
 Max Grav 5=208(LC 1), 3=42(LC 10), 4=55(LC 10)

FORCES. (lb) - Max. Comp./Max. Ten. - All forces 250 (lb) or less except when shown.

NOTES-

- 1) Wind: ASCE 7-16; Vult=130mph (3-second gust) Vasd=101mph; TCDL=4.2psf; BCDL=3.0psf; h=20ft; Cat. II; Exp B; Encl., GCpi=0.18; MWFRS (envelope) gable end zone and C-C Exterior(2E) zone; end vertical left exposed; C-C for members and forces & MWFRS for reactions shown; Lumber DOL=1.60 plate grip DOL=1.60
- 2) Building Designer / Project engineer responsible for verifying applied roof live load shown covers rain loading requirements specific to the use of this truss component.
- 3) This truss has been designed for a 10.0 psf bottom chord live load nonconcurrent with any other live loads.
- 4) * This truss has been designed for a live load of 20.0psf on the bottom chord in all areas where a rectangle 3-6-0 tall by 2-0-0 wide will fit between the bottom chord and any other members.
- 5) Refer to girder(s) for truss to truss connections.
- 6) Provide mechanical connection (by others) of truss to bearing plate capable of withstanding 7 lb uplift at joint 5, 57 lb uplift at joint 3 and 51 lb uplift at joint 4.

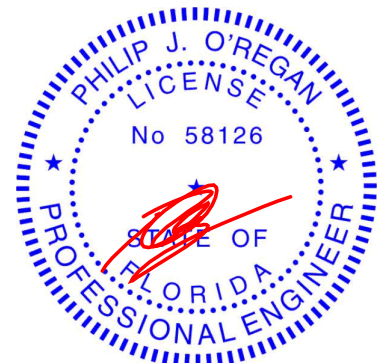

Philip J. O'Regan PE No.58126
 MiTek USA, Inc. FL Cert 6634
 6904 Parke East Blvd. Tampa FL 33610
 Date:

September 7, 2021

WARNING - Verify design parameters and READ NOTES ON THIS AND INCLUDED MITEK REFERENCE PAGE MII-7473 rev. 5/19/2020 BEFORE USE.

Design valid for use only with MiTek® connectors. This design is based only upon parameters shown, and is for an individual building component, not a truss system. Before use, the building designer must verify the applicability of design parameters and properly incorporate this design into the overall building design. Bracing indicated is to prevent buckling of individual truss web and/or chord members only. Additional temporary and permanent bracing is always required for stability and to prevent collapse with possible personal injury and property damage. For general guidance regarding the fabrication, storage, delivery, erection and bracing of trusses and truss systems, see

ANSI/TPI1 Quality Criteria, DSB-89 and BCSI Building Component

Safety Information available from Truss Plate Institute, 2670 Crain Highway, Suite 203 Waldorf, MD 20601



6904 Parke East Blvd.
 Tampa, FL 36610

Job	Truss	Truss Type	Qty	Ply	IC CONST. - LIBERTY RES.	T25256414
2918935	HJ06	Diagonal Hip Girder	1	1		

Builders FirstSource (Lake City, FL),

Lake City, FL - 32055,

8.430 s Aug 16 2021 MiTek Industries, Inc. Sat Sep 4 11:23:23 2021 Page 1
ID:b2ldskJJGjOxOjHDJJPpLTyh2aU-gjflsWbHaa3A_nsBECJHx?butmYRy6TgRFNGoOyh122

Job Reference (optional)

-2-7-6
2-7-6

5-5-3
5-5-3

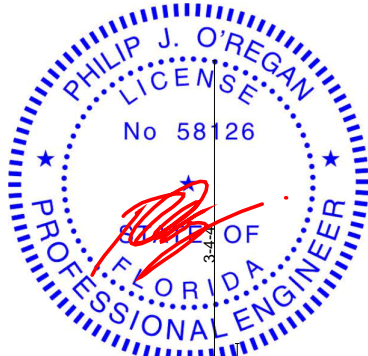

Philip J. O'Regan PE No. 58126
MiTek USA, Inc. FL Cert. 6734
6904 Parke East Blvd. Tampa FL 33610
Date:

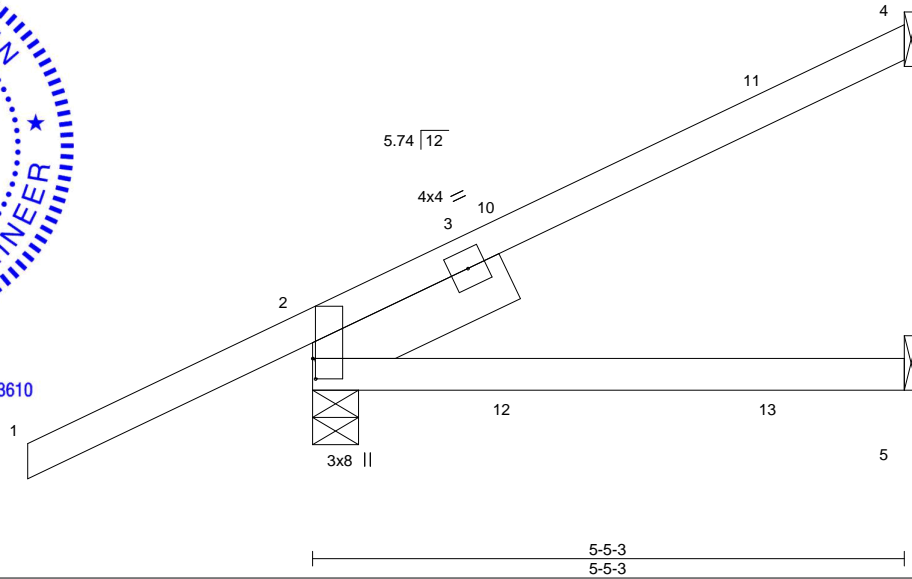

Scale = 1:21.2

Plate Offsets (X,Y)-- [2:0-2-4,0-0-5]

LOADING (psf)	SPACING-		CSI.	DEFL.	in	(loc)	l/defl	L/d	PLATES	GRIP
TCLL 20.0	Plate Grip DOL 1.25	2-0-0	TC 0.48	Vert(LL) -0.04	5-8	>999	240		MT20	244/190
TCDL 7.0	Lumber DOL 1.25		BC 0.22	Vert(CT) -0.06	5-8	>999	180			
BCLL 0.0 *	Rep Stress Incr NO		WB 0.00	Horz(CT) 0.01	2	n/a	n/a			
BCDL 10.0	Code FBC2020/TPI2014		Matrix-MP						Weight: 26 lb	FT = 20%

LUMBER-

TOP CHORD 2x4 SP No.2
BOT CHORD 2x4 SP No.2
SLIDER Left 2x6 SP No.2 1-11-8

BRACING-

TOP CHORD Structural wood sheathing directly applied or 5-5-3 oc purlins.
BOT CHORD Rigid ceiling directly applied or 10-0-0 oc bracing.

REACTIONS.

(size) 4=Mechanical, 2=0-5-1, 5=Mechanical
Max Horz 2=125(LC 26)
Max Uplift 4=-81(LC 8), 2=-122(LC 8), 5=-11(LC 8)
Max Grav 4=105(LC 32), 2=334(LC 1), 5=81(LC 3)

FORCES. (lb) - Max. Comp./Max. Ten. - All forces 250 (lb) or less except when shown.

TOP CHORD 2-4=-236/292

NOTES-

- 1) Wind: ASCE 7-16; Vult=130mph (3-second gust) Vasd=101mph; TCDL=4.2psf; BCDL=3.0psf; h=20ft; Cat. II; Exp B; Encl., GCpi=0.18; MWFRS (envelope) gable end zone; end vertical left exposed; Lumber DOL=1.60 plate grip DOL=1.60
- 2) Building Designer / Project engineer responsible for verifying applied roof live load shown covers rain loading requirements specific to the use of this truss component.
- 3) This truss has been designed for a 10.0 psf bottom chord live load nonconcurrent with any other live loads.
- 4) * This truss has been designed for a live load of 20.0psf on the bottom chord in all areas where a rectangle 3-6-0 tall by 2-0-0 wide will fit between the bottom chord and any other members.
- 5) Refer to girder(s) for truss to truss connections.
- 6) Provide mechanical connection (by others) of truss to bearing plate capable of withstanding 81 lb uplift at joint 4, 122 lb uplift at joint 2 and 11 lb uplift at joint 5.
- 7) Hanger(s) or other connection device(s) shall be provided sufficient to support concentrated load(s) 50 lb down and 105 lb up at 1-9-14, and 77 lb down and 24 lb up at 1-11-9, and 67 lb down and 44 lb up at 4-3-3 on top chord, and 8 lb down and 64 lb up at 1-9-14, and 13 lb down and 2 lb up at 1-11-9, and 20 lb down and 7 lb up at 4-3-3 on bottom chord. The design/selection of such connection device(s) is the responsibility of others.
- 8) In the LOAD CASE(S) section, loads applied to the face of the truss are noted as front (F) or back (B).

LOAD CASE(S) Standard

- 1) Dead + Roof Live (balanced): Lumber Increase=1.25, Plate Increase=1.25
Uniform Loads (plf)
Vert: 1-4=-54, 5-6=-20
Concentrated Loads (lb)
Vert: 10=27(B) 12=32(F=2, B=30) 13=7(B)

September 7, 2021

WARNING - Verify design parameters and READ NOTES ON THIS AND INCLUDED MITEK REFERENCE PAGE MII-7473 rev. 5/19/2020 BEFORE USE.

Design valid for use only with MiTek® connectors. This design is based only upon parameters shown, and is for an individual building component, not a truss system. Before use, the building designer must verify the applicability of design parameters and properly incorporate this design into the overall building design. Bracing indicated is to prevent buckling of individual truss web and/or chord members only. Additional temporary and permanent bracing is always required for stability and to prevent collapse with possible personal injury and property damage. For general guidance regarding the fabrication, storage, delivery, erection and bracing of trusses and truss systems, see

ANSI/TPI1 Quality Criteria, DSB-89 and BCSI Building Component

Safety Information available from Truss Plate Institute, 2670 Crain Highway, Suite 203 Waldorf, MD 20601



6904 Parke East Blvd.
Tampa, FL 33610

Job	Truss	Truss Type	Qty	Ply	IC CONST. - LIBERTY RES.	T25256415
2918935	HJ10	Diagonal Hip Girder	2	1		

Builders FirstSource (Lake City, FL),

Lake City, FL - 32055,

8.430 s Aug 16 2021 MiTek Industries, Inc. Sat Sep 4 11:23:24 2021 Page 1
ID:b2ldskJGjOxOjHDJPP?LTyh2aU-8uD73scvLuB1cxRNnwqWUD73d9o9hWvpgu7pKqyh121

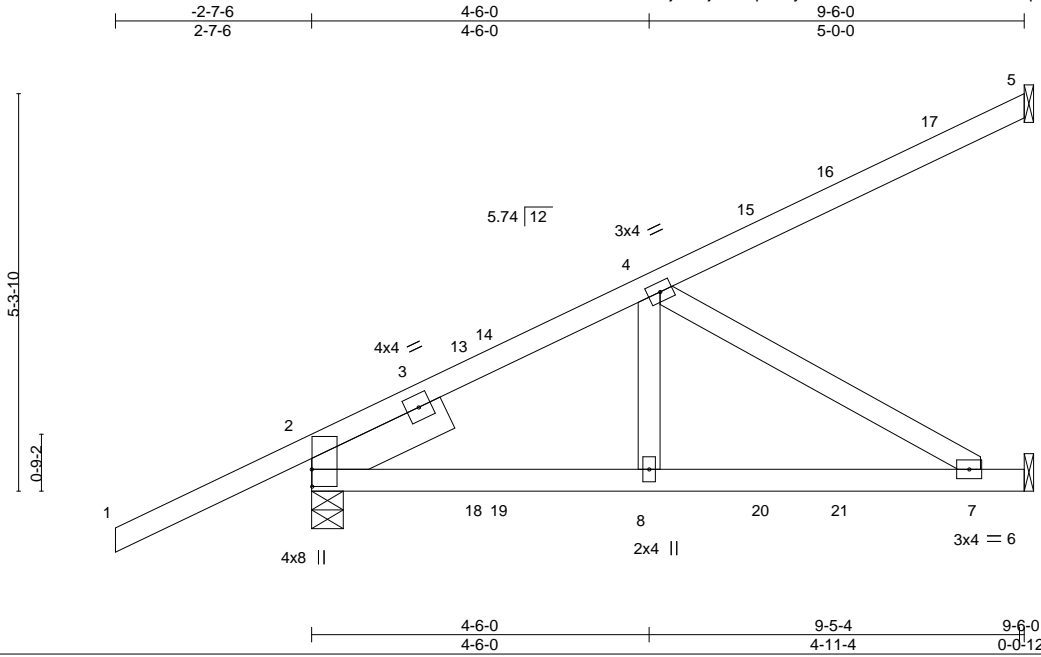

Scale = 1:30.7

Plate Offsets (X,Y)-- [2:0-2-12,0-0-1]

LOADING (psf)	SPACING-	CSI.	DEFL.	PLATES	GRIP
TCLL 20.0	2-0-0	TC 0.48	in (loc) l/defl L/d	MT20	244/190
TCDL 7.0	Plate Grip DOL 1.25	BC 0.51	Vert(LL) 0.06 7-8 >999 240		
BCLL 0.0 *	Lumber DOL 1.25	WB 0.24	Vert(CT) -0.11 7-8 >999 180		
BCDL 10.0	Rep Stress Incr NO	Matrix-MS	Horz(CT) -0.01 5 n/a n/a		
	Code FBC2020/TP12014			Weight: 50 lb	FT = 20%

LUMBER-
 TOP CHORD 2x4 SP No.2
 BOT CHORD 2x4 SP No.2
 WEBS 2x4 SP No.3
 SLIDER Left 2x6 SP No.2 1-11-8

BRACING-
 TOP CHORD Structural wood sheathing directly applied or 6-0-0 oc purlins.
 BOT CHORD Rigid ceiling directly applied or 10-0-0 oc bracing.

REACTIONS. (size) 5=Mechanical, 2=0-5-1, 6=Mechanical
 Max Horz 2=187(LC 8)
 Max Uplift 5=-194(LC 8), 2=-183(LC 8), 6=-130(LC 8)
 Max Grav 5=222(LC 1), 2=505(LC 1), 6=271(LC 32)

FORCES. (lb) - Max. Comp./Max. Ten. - All forces 250 (lb) or less except when shown.
 TOP CHORD 2-4=-541/179
 BOT CHORD 2-8=-255/407, 7-8=-255/407
 WEBS 4-8=-17/253, 4-7=-472/296

- NOTES-**
- 1) Wind: ASCE 7-16; Vult=130mph (3-second gust) Vasd=101mph; TCDL=4.2psf; BCDL=3.0psf; h=20ft; Cat. II; Exp B; Encl., GCpi=0.18; MWFRS (envelope) gable end zone; end vertical left exposed; Lumber DOL=1.60 plate grip DOL=1.60
 - 2) Building Designer / Project engineer responsible for verifying applied roof live load shown covers rain loading requirements specific to the use of this truss component.
 - 3) This truss has been designed for a 10.0 psf bottom chord live load nonconcurrent with any other live loads.
 - 4) * This truss has been designed for a live load of 20.0psf on the bottom chord in all areas where a rectangle 3-6-0 tall by 2-0-0 wide will fit between the bottom chord and any other members.
 - 5) Refer to girder(s) for truss to truss connections.
 - 6) Provide mechanical connection (by others) of truss to bearing plate capable of withstanding 194 lb uplift at joint 5, 183 lb uplift at joint 2 and 130 lb uplift at joint 6.
 - 7) Hanger(s) or other connection device(s) shall be provided sufficient to support concentrated load(s) 51 lb down and 85 lb up at 2-2-8, 82 lb down and 35 lb up at 2-6-9, 72 lb down and 51 lb up at 4-7-13, 123 lb down and 99 lb up at 6-0-7, and 95 lb down and 91 lb up at 7-1-2, and 103 lb down and 122 lb up at 9-5-4 on top chord, and 6 lb down and 52 lb up at 2-2-8, 19 lb down at 2-6-9, 22 lb down and 8 lb up at 4-7-13, and 50 lb down and 21 lb up at 6-0-7, and 38 lb down and 17 lb up at 7-1-2 on bottom chord. The design/selection of such connection device(s) is the responsibility of others.
 - 8) In the LOAD CASE(S) section, loads applied to the face of the truss are noted as front (F) or back (B).

LOAD CASE(S) Standard
 1) Dead + Roof Live (balanced): Lumber Increase=1.25, Plate Increase=1.25
 Uniform Loads (plf)
 Vert: 1-5=-54, 6-9=-20
 Concentrated Loads (lb)
 Vert: 5=-89(B) 8=5(B) 13=21(B) 15=-37(F) 16=-15(B) 18=25(B) 19=-1(F) 20=-36(F) 21=-11(B)

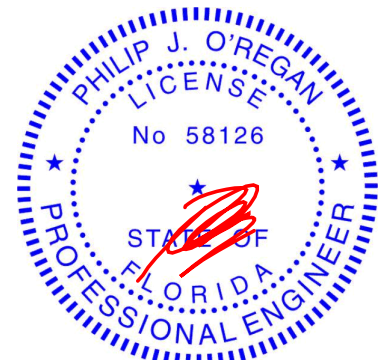

Philip J. O'Regan PE No.58126
 MiTek USA, Inc. FL Cert 6634
 6904 Parke East Blvd. Tampa FL 33610
 Date:

September 7, 2021

WARNING - Verify design parameters and READ NOTES ON THIS AND INCLUDED MITEK REFERENCE PAGE MII-7473 rev. 5/19/2020 BEFORE USE.
 Design valid for use only with MiTek® connectors. This design is based only upon parameters shown, and is for an individual building component, not a truss system. Before use, the building designer must verify the applicability of design parameters and properly incorporate this design into the overall building design. Bracing indicated is to prevent buckling of individual truss web and/or chord members only. Additional temporary and permanent bracing is always required for stability and to prevent collapse with possible personal injury and property damage. For general guidance regarding the fabrication, storage, delivery, erection and bracing of trusses and truss systems, see **ANSI/TP1 Quality Criteria, DSB-89 and BCSI Building Component Safety Information** available from Truss Plate Institute, 2670 Crain Highway, Suite 203 Waldorf, MD 20601



Job 2918935	Truss PB01	Truss Type GABLE	Qty 1	Ply 1	IC CONST. - LIBERTY RES. Job Reference (optional)	T25256416
----------------	---------------	---------------------	----------	----------	--	-----------

Builders FirstSource (Lake City,FL), Lake City, FL - 32055,

8.430 s Aug 16 2021 MiTek Industries, Inc. Sat Sep 4 11:23:25 2021 Page 1
ID:b2ldskJJGjOxOjHDJPP?LTyh2aU-c4nVHCdY6BJtD40aLdLI0QgJPZFeQ0HvyYsNsHyh120



Scale = 1:30.5

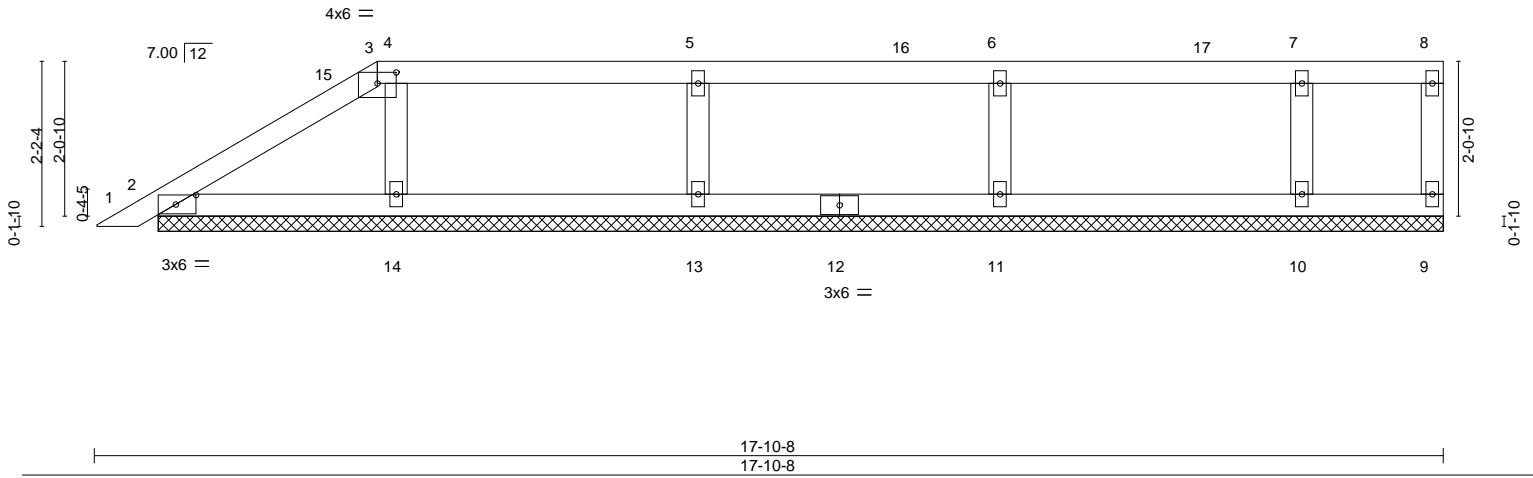

Plate Offsets (X,Y)-- [2:0-3-3,0-1-8], [3:0-3-0,0-1-12]

LOADING (psf)	SPACING-	CSI.	DEFL.	in (loc)	l/defl	L/d	PLATES	GRIP
TCLL 20.0	Plate Grip DOL 1.25	TC 0.15	Vert(LL) -0.00	1	n/r	120	MT20	244/190
TCDL 7.0	Lumber DOL 1.25	BC 0.11	Vert(CT) 0.00	1	n/r	120		
BCLL 0.0 *	Rep Stress Incr YES	WB 0.04	Horz(CT) -0.00	9	n/a	n/a		
BCDL 10.0	Code FBC2020/TPI2014	Matrix-S					Weight: 64 lb	FT = 20%

LUMBER-	BRACING-
TOP CHORD 2x4 SP No.2	TOP CHORD Structural wood sheathing directly applied or 6-0-0 oc purlins, except end verticals.
BOT CHORD 2x4 SP No.2	BOT CHORD Rigid ceiling directly applied or 6-0-0 oc bracing.
WEBS 2x4 SP No.3	
OTHERS 2x4 SP No.3	

REACTIONS. All bearings 17-0-5.
 (lb) - Max Horz 2=69(LC 12)
 Max Uplift All uplift 100 lb or less at joint(s) 9, 2, 14, 13, 11, 10
 Max Grav All reactions 250 lb or less at joint(s) 9, 2 except 14=285(LC 1), 13=309(LC 24), 11=304(LC 1), 10=252(LC 24)

FORCES. (lb) - Max. Comp./Max. Ten. - All forces 250 (lb) or less except when shown.

- NOTES-**
- Unbalanced roof live loads have been considered for this design.
 - Wind: ASCE 7-16; Vult=130mph (3-second gust) Vasd=101mph; TC DL=4.2psf; BCDL=3.0psf; h=20ft; Cat. II; Exp B; Encl., GCpi=0.18; MWFRS (envelope) gable end zone and C-C Exterior(2E) 0-3-11 to 3-3-11, Interior(1) 3-3-11 to 3-9-0, Exterior(2R) 3-9-0 to 8-0-0, Interior(1) 8-0-0 to 17-8-12 zone;C-C for members and forces & MWFRS for reactions shown; Lumber DOL=1.60 plate grip DOL=1.60
 - Truss designed for wind loads in the plane of the truss only. For studs exposed to wind (normal to the face), see Standard Industry Gable End Details as applicable, or consult qualified building designer as per ANSI/TPI 1.
 - Building Designer / Project engineer responsible for verifying applied roof live load shown covers rain loading requirements specific to the use of this truss component.
 - Provide adequate drainage to prevent water ponding.
 - All plates are 2x4 MT20 unless otherwise indicated.
 - Gable requires continuous bottom chord bearing.
 - Gable studs spaced at 4-0-0 oc.
 - This truss has been designed for a 10.0 psf bottom chord live load nonconcurrent with any other live loads.
 - * This truss has been designed for a live load of 20.0psf on the bottom chord in all areas where a rectangle 3-6-0 tall by 2-0-0 wide will fit between the bottom chord and any other members.
 - Provide mechanical connection (by others) of truss to bearing plate capable of withstanding 100 lb uplift at joint(s) 9, 2, 14, 13, 11, 10.
 - See Standard Industry Piggyback Truss Connection Detail for Connection to base truss as applicable, or consult qualified building designer.

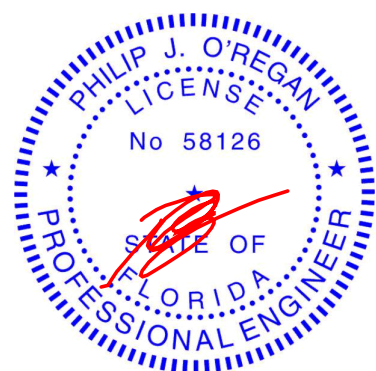

Philip J. O'Regan PE No.58126
 MiTek USA, Inc. FL Cert 6634
 6904 Parke East Blvd. Tampa FL 33610
 Date: September 7, 2021

Job 2918935	Truss PB02	Truss Type GABLE	Qty 1	Ply 1	IC CONST. - LIBERTY RES. Job Reference (optional)	T25256417
----------------	---------------	---------------------	----------	----------	--	-----------

Builders FirstSource (Lake City, FL), Lake City, FL - 32055,

8.430 s Aug 16 2021 MiTek Industries, Inc. Sat Sep 4 11:23:26 2021 Page 1
ID:b2ldskJJGjOxOjHDJPP?LTyh2aU-4GLtUYdAtVRkrEbmVLS_ZeDUHzbs9Ta67CcwOjyh12?



Scale = 1:30.5

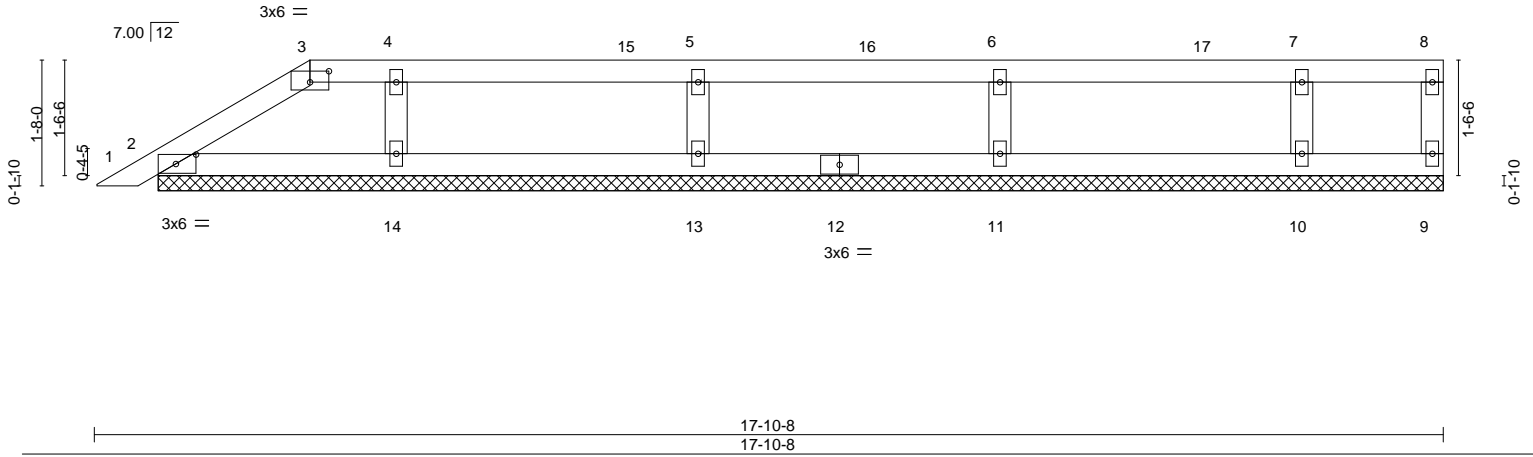

Plate Offsets (X,Y)-- [2:0-3-3,0-1-8], [3:0-3-0,0-1-12]

LOADING (psf)	SPACING-	CSI.	DEFL.	in (loc)	l/defl	L/d	PLATES	GRIP
TCLL 20.0	Plate Grip DOL 1.25	TC 0.15	Vert(LL) -0.00	1	n/r	120	MT20	244/190
TCDL 7.0	Lumber DOL 1.25	BC 0.11	Vert(CT) 0.00	1	n/r	120		
BCLL 0.0 *	Rep Stress Incr YES	WB 0.04	Horz(CT) 0.00	9	n/a	n/a		
BCDL 10.0	Code FBC2020/TPI2014	Matrix-S					Weight: 60 lb	FT = 20%

LUMBER-	BRACING-
TOP CHORD 2x4 SP No.2	TOP CHORD Structural wood sheathing directly applied or 6-0-0 oc purlins, except end verticals.
BOT CHORD 2x4 SP No.2	BOT CHORD Rigid ceiling directly applied or 6-0-0 oc bracing.
WEBS 2x4 SP No.3	
OTHERS 2x4 SP No.3	

REACTIONS. All bearings 17-0-5.
 (lb) - Max Horz 2=51(LC 12)
 Max Uplift All uplift 100 lb or less at joint(s) 9, 2, 14, 13, 11, 10
 Max Grav All reactions 250 lb or less at joint(s) 9, 2 except 14=290(LC 1), 13=301(LC 24), 11=306(LC 1), 10=250(LC 24)

FORCES. (lb) - Max. Comp./Max. Ten. - All forces 250 (lb) or less except when shown.

- NOTES-**
- Unbalanced roof live loads have been considered for this design.
 - Wind: ASCE 7-16; Vult=130mph (3-second gust) Vasd=101mph; TCCL=4.2psf; BCDL=3.0psf; h=20ft; Cat. II; Exp B; Encl., GCpi=0.18; MWFRS (envelope) gable end zone and C-C Exterior(2E) 0-3-11 to 2-10-5, Exterior(2R) 2-10-5 to 7-1-3, Interior(1) 7-1-3 to 17-8-12 zone; C-C for members and forces & MWFRS for reactions shown; Lumber DOL=1.60 plate grip DOL=1.60
 - Truss designed for wind loads in the plane of the truss only. For studs exposed to wind (normal to the face), see Standard Industry Gable End Details as applicable, or consult qualified building designer as per ANSI/TPI 1.
 - Building Designer / Project engineer responsible for verifying applied roof live load shown covers rain loading requirements specific to the use of this truss component.
 - Provide adequate drainage to prevent water ponding.
 - All plates are 2x4 MT20 unless otherwise indicated.
 - Gable requires continuous bottom chord bearing.
 - Gable studs spaced at 4-0-0 oc.
 - This truss has been designed for a 10.0 psf bottom chord live load nonconcurrent with any other live loads.
 - * This truss has been designed for a live load of 20.0psf on the bottom chord in all areas where a rectangle 3-6-0 tall by 2-0-0 wide will fit between the bottom chord and any other members.
 - Provide mechanical connection (by others) of truss to bearing plate capable of withstanding 100 lb uplift at joint(s) 9, 2, 14, 13, 11, 10.
 - See Standard Industry Piggyback Truss Connection Detail for Connection to base truss as applicable, or consult qualified building designer.

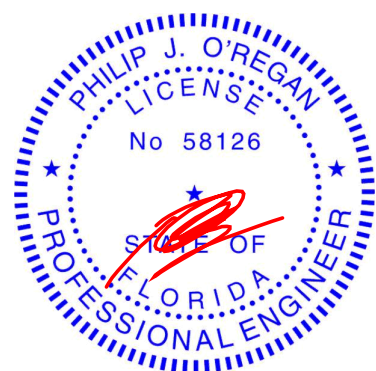

Philip J. O'Regan PE No.58126
 MiTek USA, Inc. FL Cert 6634
 6904 Parke East Blvd. Tampa FL 33610
 Date: September 7, 2021

Job 2918935	Truss PB03	Truss Type Piggyback	Qty 3	Ply 1	IC CONST. - LIBERTY RES. Job Reference (optional)	T25256418
----------------	---------------	-------------------------	----------	----------	--	-----------

Builders FirstSource (Lake City,FL),

Lake City, FL - 32055,

8.430 s Aug 16 2021 MiTek Industries, Inc. Sat Sep 4 11:23:27 2021 Page 1
ID:b2lidskJGjOxOjHDJPP?LTyh2aU-YTvfiteopZbTOAyT2ND6rifsNxhuw8FMsLTx9yh12_

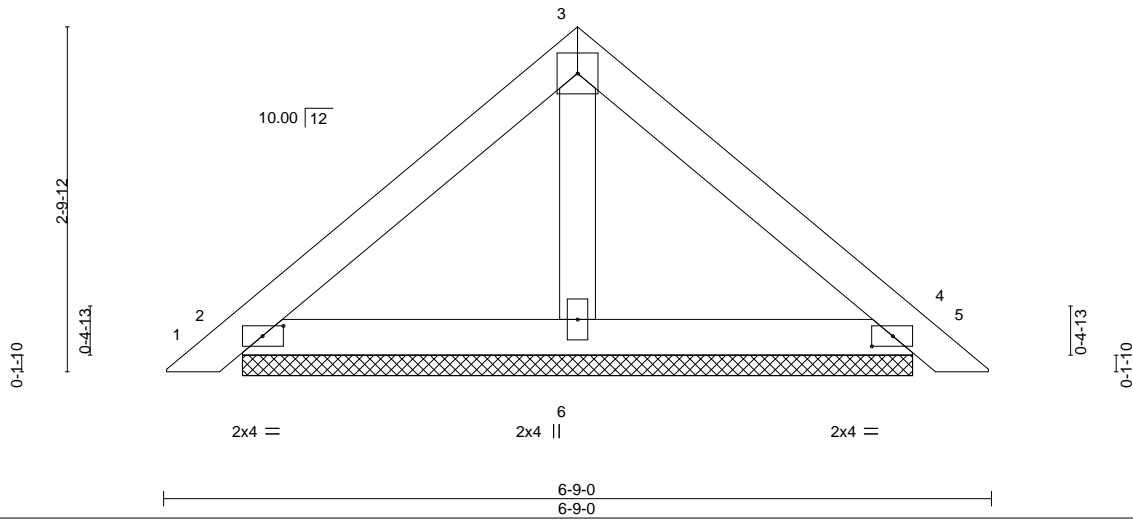
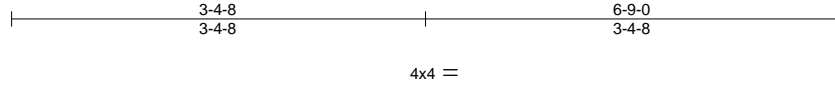

Plate Offsets (X,Y)-- [2:0-2-1,0-1-0], [4:0-2-1,0-1-0]

LOADING (psf)	SPACING-	CSI.	DEFL.	in (loc)	l/defl	L/d	PLATES	GRIP
TCLL 20.0	Plate Grip DOL 1.25	TC 0.16	Vert(LL)	0.00	5	n/r	MT20	244/190
TCDL 7.0	Lumber DOL 1.25	BC 0.08	Vert(CT)	0.00	5	n/r		
BCLL 0.0 *	Rep Stress Incr YES	WB 0.02	Horz(CT)	0.00	4	n/a		
BCDL 10.0	Code FBC2020/TPI2014	Matrix-P					Weight: 24 lb	FT = 20%

LUMBER-
TOP CHORD 2x4 SP No.2
BOT CHORD 2x4 SP No.2
OTHERS 2x4 SP No.3

BRACING-
TOP CHORD Structural wood sheathing directly applied or 6-0-0 oc purlins.
BOT CHORD Rigid ceiling directly applied or 10-0-0 oc bracing.

REACTIONS. (size) 2=5-5-9, 4=5-5-9, 6=5-5-9
Max Horz 2=-58(LC 10)
Max Uplift 2=-42(LC 12), 4=-49(LC 13), 6=-8(LC 12)
Max Grav 2=138(LC 1), 4=138(LC 1), 6=171(LC 1)

FORCES. (lb) - Max. Comp./Max. Ten. - All forces 250 (lb) or less except when shown.

- NOTES-**
- Unbalanced roof live loads have been considered for this design.
 - Wind: ASCE 7-16; Vult=130mph (3-second gust) Vasd=101mph; TCDL=4.2psf; BCDL=3.0psf; h=20ft; Cat. II; Exp B; Encl., GCpi=0.18; MWFRS (envelope) gable end zone and C-C Exterior(2E) zone;C-C for members and forces & MWFRS for reactions shown; Lumber DOL=1.60 plate grip DOL=1.60
 - Building Designer / Project engineer responsible for verifying applied roof live load shown covers rain loading requirements specific to the use of this truss component.
 - Gable requires continuous bottom chord bearing.
 - This truss has been designed for a 10.0 psf bottom chord live load nonconcurrent with any other live loads.
 - * This truss has been designed for a live load of 20.0psf on the bottom chord in all areas where a rectangle 3-6-0 tall by 2-0-0 wide will fit between the bottom chord and any other members.
 - Provide mechanical connection (by others) of truss to bearing plate capable of withstanding 100 lb uplift at joint(s) 2, 4, 6.
 - See Standard Industry Piggyback Truss Connection Detail for Connection to base truss as applicable, or consult qualified building designer.

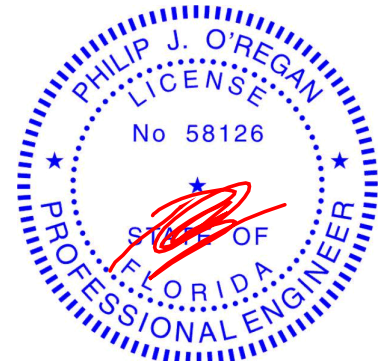

Philip J. O'Regan PE No.58126
MiTek USA, Inc. FL Cert 6634
6904 Parke East Blvd. Tampa FL 33610
Date:

September 7, 2021

WARNING - Verify design parameters and READ NOTES ON THIS AND INCLUDED MITEK REFERENCE PAGE MII-7473 rev. 5/19/2020 BEFORE USE.

Design valid for use only with MiTek® connectors. This design is based only upon parameters shown, and is for an individual building component, not a truss system. Before use, the building designer must verify the applicability of design parameters and properly incorporate this design into the overall building design. Bracing indicated is to prevent buckling of individual truss web and/or chord members only. Additional temporary and permanent bracing is always required for stability and to prevent collapse with possible personal injury and property damage. For general guidance regarding the fabrication, storage, delivery, erection and bracing of trusses and truss systems, see

ANSI/TPI1 Quality Criteria, DSB-89 and BCSI Building Component

Safety Information available from Truss Plate Institute, 2670 Crain Highway, Suite 203 Waldorf, MD 20601



6904 Parke East Blvd.
Tampa, FL 36610

Job	Truss	Truss Type	Qty	Ply	IC CONST. - LIBERTY RES.	T25256419
2918935	PB03G	GABLE	1	1	Job Reference (optional)	

Builders FirstSource (Lake City, FL),

Lake City, FL - 32055,

8.430 s Aug 16 2021 MiTek Industries, Inc. Sat Sep 4 11:23:28 2021 Page 1
ID:b2ldskJGjOxOjHDJpp?LTyh2aU-1fTevDfQP6hS4YI90muSe3rLnIHdNSPbW51Scyh1z

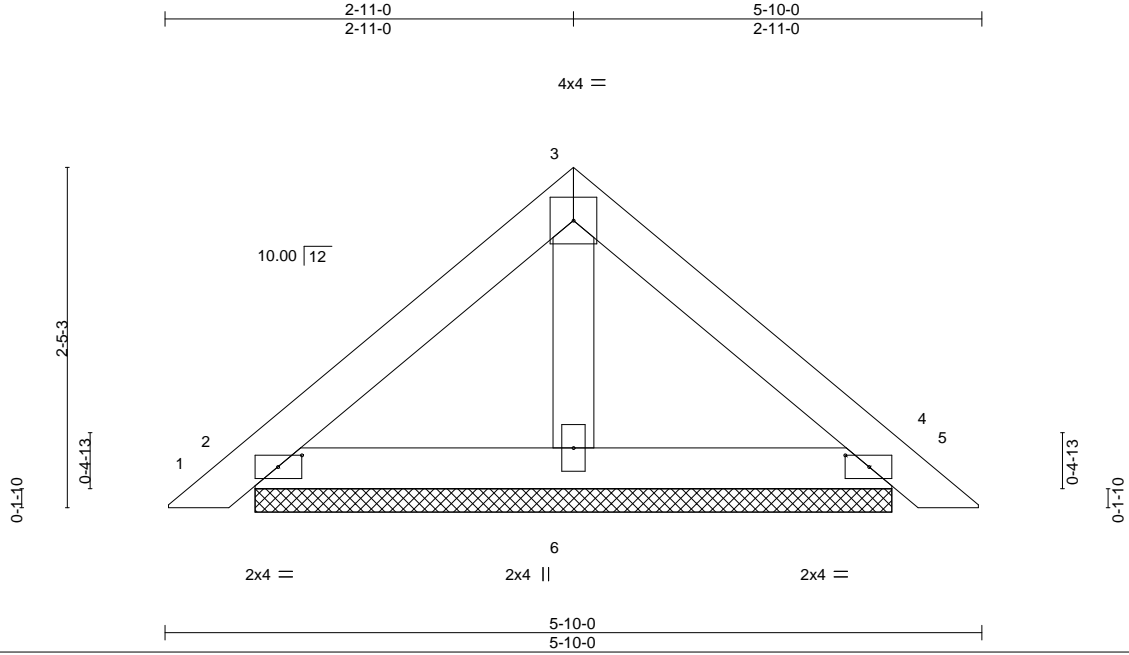

Scale = 1:16.5

Plate Offsets (X,Y)-- [2:0-2-1,0-1-0], [4:0-2-1,0-1-0]

LOADING (psf)	SPACING-	CSL.	DEFL.	in (loc)	l/defl	L/d	PLATES	GRIP
TCLL 20.0	Plate Grip DOL 1.25	TC 0.11	Vert(LL)	0.00	5	n/r	MT20	244/190
TCDL 7.0	Lumber DOL 1.25	BC 0.05	Vert(CT)	0.00	5	n/r		
BCLL 0.0 *	Rep Stress Incr YES	WB 0.02	Horz(CT)	0.00	4	n/a		
BCDL 10.0	Code FBC2020/TPI2014	Matrix-P					Weight: 20 lb	FT = 20%

LUMBER-

TOP CHORD 2x4 SP No.2
BOT CHORD 2x4 SP No.2
OTHERS 2x4 SP No.3

BRACING-

TOP CHORD Structural wood sheathing directly applied or 5-10-0 oc purlins.
BOT CHORD Rigid ceiling directly applied or 10-0-0 oc bracing.

REACTIONS.

(size) 2=4-6-9, 4=4-6-9, 6=4-6-9
Max Horz 2=-49(LC 10)
Max Uplift 2=-37(LC 12), 4=-43(LC 13), 6=-6(LC 12)
Max Grav 2=119(LC 1), 4=119(LC 1), 6=142(LC 1)

FORCES. (lb) - Max. Comp./Max. Ten. - All forces 250 (lb) or less except when shown.

NOTES-

- Unbalanced roof live loads have been considered for this design.
- Wind: ASCE 7-16; Vult=130mph (3-second gust) Vasd=101mph; TCCL=4.2psf; BCDL=3.0psf; h=20ft; Cat. II; Exp B; Encl., GCpi=0.18; MWFRS (envelope) gable end zone and C-C Exterior(2E) zone; C-C for members and forces & MWFRS for reactions shown; Lumber DOL=1.60 plate grip DOL=1.60
- Truss designed for wind loads in the plane of the truss only. For studs exposed to wind (normal to the face), see Standard Industry Gable End Details as applicable, or consult qualified building designer as per ANSI/TPI 1.
- Building Designer / Project engineer responsible for verifying applied roof live load shown covers rain loading requirements specific to the use of this truss component.
- Gable requires continuous bottom chord bearing.
- Gable studs spaced at 2-0-0 oc.
- This truss has been designed for a 10.0 psf bottom chord live load nonconcurrent with any other live loads.
- * This truss has been designed for a live load of 20.0psf on the bottom chord in all areas where a rectangle 3-6-0 tall by 2-0-0 wide will fit between the bottom chord and any other members.
- Provide mechanical connection (by others) of truss to bearing plate capable of withstanding 100 lb uplift at joint(s) 2, 4, 6.
- See Standard Industry Piggyback Truss Connection Detail for Connection to base truss as applicable, or consult qualified building designer.

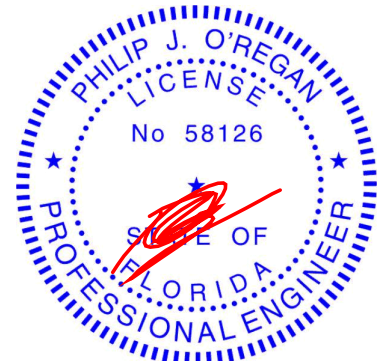

Philip J. O'Regan PE No.58126
MiTek USA, Inc. FL Cert 6634
6904 Parke East Blvd. Tampa FL 33610
Date:

September 7, 2021

WARNING - Verify design parameters and READ NOTES ON THIS AND INCLUDED MITEK REFERENCE PAGE MII-7473 rev. 5/19/2020 BEFORE USE.

Design valid for use only with MiTek® connectors. This design is based only upon parameters shown, and is for an individual building component, not a truss system. Before use, the building designer must verify the applicability of design parameters and properly incorporate this design into the overall building design. Bracing indicated is to prevent buckling of individual truss web and/or chord members only. Additional temporary and permanent bracing is always required for stability and to prevent collapse with possible personal injury and property damage. For general guidance regarding the fabrication, storage, delivery, erection and bracing of trusses and truss systems, see

ANSI/TPI1 Quality Criteria, DSB-89 and BCSI Building Component

Safety Information available from Truss Plate Institute, 2670 Crain Highway, Suite 203 Waldorf, MD 20601



6904 Parke East Blvd.
Tampa, FL 36610

Job	Truss	Truss Type	Qty	Ply	IC CONST. - LIBERTY RES.	T25256420
2918935	PB04	Piggyback	1	1	Job Reference (optional)	

Builders FirstSource (Lake City,FL), Lake City, FL - 32055,

8.430 s Aug 16 2021 MiTek Industries, Inc. Sat Sep 4 11:23:29 2021 Page 1
ID:b2ldskJGjOxOjHDJPP?LTyh2aU-Vr006Zg2AQpJiiJLaTQhBGr1IAe4MqyYpAqa_2yh11y

Scale = 1:10.9

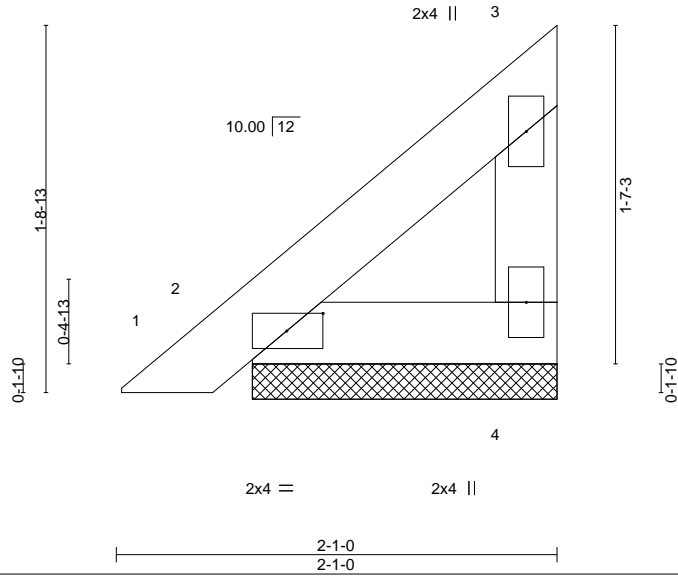

Plate Offsets (X,Y)--	[2:0-2-1,0-1-0]				
LOADING (psf)	SPACING- 2-0-0	CSI.	DEFL. in (loc) l/defl L/d	PLATES	GRIP
TCLL 20.0	Plate Grip DOL 1.25	TC 0.03	Vert(LL) -0.00 1 n/r 120	MT20	244/190
TCDL 7.0	Lumber DOL 1.25	BC 0.02	Vert(CT) 0.00 1 n/r 120		
BCLL 0.0 *	Rep Stress Incr YES	WB 0.00	Horz(CT) 0.00 n/a n/a		
BCDL 10.0	Code FBC2020/TPI2014	Matrix-P		Weight: 8 lb	FT = 20%

LUMBER-

TOP CHORD 2x4 SP No.2
BOT CHORD 2x4 SP No.2
WEBS 2x4 SP No.3

BRACING-

TOP CHORD Structural wood sheathing directly applied or 2-1-0 oc purlins, except end verticals.
BOT CHORD Rigid ceiling directly applied or 10-0-0 oc bracing.

REACTIONS.

(size) 4=1-5-5, 2=1-5-5
Max Horz 2=47(LC 12)
Max Uplift 4=-28(LC 12), 2=-6(LC 12)
Max Grav 4=49(LC 19), 2=73(LC 1)

FORCES. (lb) - Max. Comp./Max. Ten. - All forces 250 (lb) or less except when shown.

NOTES-

- 1) Wind: ASCE 7-16; Vult=130mph (3-second gust) Vasd=101mph; TC DL=4.2psf; BCDL=3.0psf; h=20ft; Cat. II; Exp B; Encl., GCpi=0.18; MWFRS (envelope) gable end zone and C-C Exterior(2E) zone; C-C for members and forces & MWFRS for reactions shown; Lumber DOL=1.60 plate grip DOL=1.60
- 2) Building Designer / Project engineer responsible for verifying applied roof live load shown covers rain loading requirements specific to the use of this truss component.
- 3) Gable requires continuous bottom chord bearing.
- 4) This truss has been designed for a 10.0 psf bottom chord live load nonconcurrent with any other live loads.
- 5) * This truss has been designed for a live load of 20.0psf on the bottom chord in all areas where a rectangle 3-6-0 tall by 2-0-0 wide will fit between the bottom chord and any other members.
- 6) Provide mechanical connection (by others) of truss to bearing plate capable of withstanding 100 lb uplift at joint(s) 4, 2.
- 7) See Standard Industry Piggyback Truss Connection Detail for Connection to base truss as applicable, or consult qualified building designer.

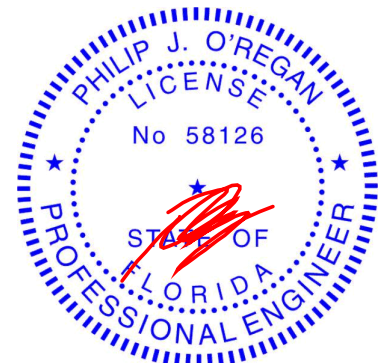

Philip J. O'Regan PE No.58126
MiTek USA, Inc. FL Cert 6634
6904 Parke East Blvd. Tampa FL 33610
Date:

September 7, 2021

WARNING - Verify design parameters and READ NOTES ON THIS AND INCLUDED MITEK REFERENCE PAGE MII-7473 rev. 5/19/2020 BEFORE USE.

Design valid for use only with MiTek® connectors. This design is based only upon parameters shown, and is for an individual building component, not a truss system. Before use, the building designer must verify the applicability of design parameters and properly incorporate this design into the overall building design. Bracing indicated is to prevent buckling of individual truss web and/or chord members only. Additional temporary and permanent bracing is always required for stability and to prevent collapse with possible personal injury and property damage. For general guidance regarding the fabrication, storage, delivery, erection and bracing of trusses and truss systems, see

ANSI/TPI1 Quality Criteria, DSB-89 and BCSI Building Component

Safety Information available from Truss Plate Institute, 2670 Crain Highway, Suite 203 Waldorf, MD 20601



6904 Parke East Blvd.
Tampa, FL 36610

Job	Truss	Truss Type	Qty	Ply	IC CONST. - LIBERTY RES.	T25256421
2918935	T01G	Common Supported Gable	1	1	Job Reference (optional)	

Builders FirstSource (Lake City,FL), Lake City, FL - 32055,

8.430 s Aug 16 2021 MiTek Industries, Inc. Sat Sep 4 11:23:30 2021 Page 1
ID:b2ldsklJGjOxOjHDJpp?LTyh2aU-z2aOKvvgxkxAKsuX8AxwJUN9Eaz05HOH2qa8XUyh11x

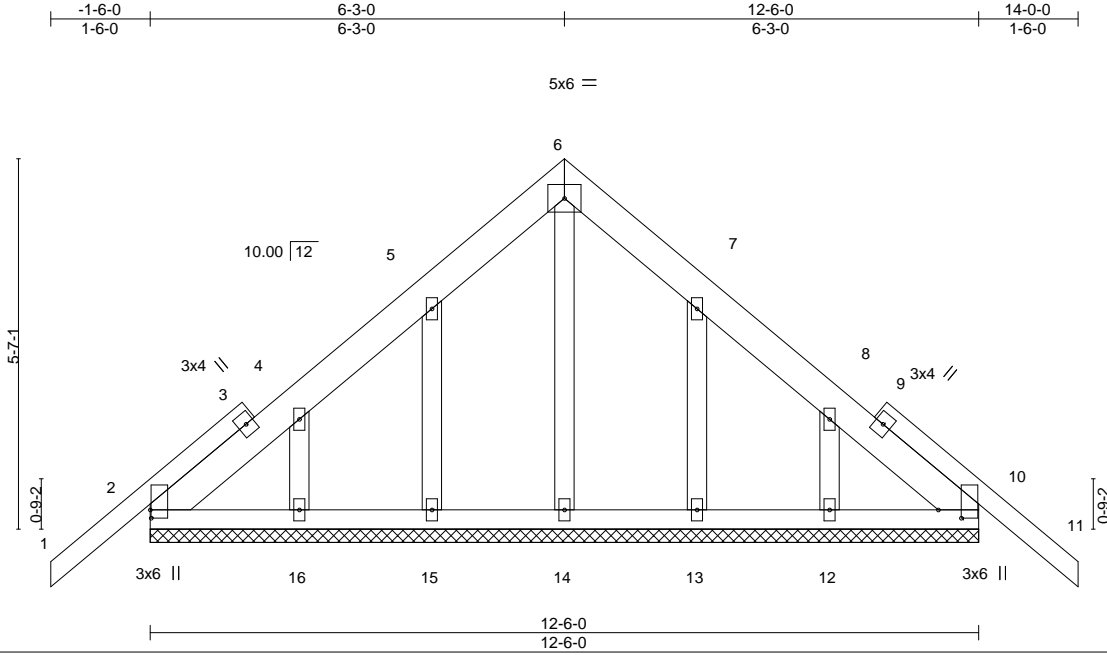

Scale = 1:34.8

LOADING (psf)		SPACING-		CSI.		DEFL.				PLATES		GRIP	
TCLL	20.0	Plate Grip DOL	1.25	TC	0.15	Vert(LL)	-0.01	11	n/r	120	MT20	244/190	
TCDL	7.0	Lumber DOL	1.25	BC	0.04	Vert(CT)	-0.01	11	n/r	120	Weight: 90 lb FT = 20%		
BCLL	0.0 *	Rep Stress Incr	YES	WB	0.05	Horz(CT)	0.00	10	n/a	n/a			
BCDL	10.0	Code	FBC2020/TPI2014	Matrix-S									

LUMBER-		BRACING-	
TOP CHORD	2x6 SP No.2 *Except* 1-3,9-11: 2x4 SP No.2	TOP CHORD	Structural wood sheathing directly applied or 6-0-0 oc purlins.
BOT CHORD	2x4 SP No.2	BOT CHORD	Rigid ceiling directly applied or 10-0-0 oc bracing.
OTHERS	2x4 SP No.3		

REACTIONS. All bearings 12-6-0.
(lb) - Max Horz 2=-132(LC 10)
Max Uplift All uplift 100 lb or less at joint(s) 2, 10, 15, 16, 13, 12
Max Grav All reactions 250 lb or less at joint(s) 2, 10, 14, 15, 16, 13, 12

FORCES. (lb) - Max. Comp./Max. Ten. - All forces 250 (lb) or less except when shown.

- NOTES-**
- Unbalanced roof live loads have been considered for this design.
 - Wind: ASCE 7-16; Vult=130mph (3-second gust) Vasd=101mph; TC DL=4.2psf; BCDL=3.0psf; h=20ft; Cat. II; Exp B; Encl., GCpi=0.18; MWFRS (envelope) gable end zone and C-C Corner(3E) -1-6-0 to 1-6-0, Exterior(2N) 1-6-0 to 6-3-0, Corner(3R) 6-3-0 to 9-3-0, Exterior(2N) 9-3-0 to 14-0-0 zone;C-C for members and forces & MWFRS for reactions shown; Lumber DOL=1.60 plate grip DOL=1.60
 - Truss designed for wind loads in the plane of the truss only. For studs exposed to wind (normal to the face), see Standard Industry Gable End Details as applicable, or consult qualified building designer as per ANSI/TPI 1.
 - Building Designer / Project engineer responsible for verifying applied roof live load shown covers rain loading requirements specific to the use of this truss component.
 - All plates are 2x4 MT20 unless otherwise indicated.
 - Gable requires continuous bottom chord bearing.
 - Gable studs spaced at 2-0-0 oc.
 - This truss has been designed for a 10.0 psf bottom chord live load nonconcurrent with any other live loads.
 - * This truss has been designed for a live load of 20.0psf on the bottom chord in all areas where a rectangle 3-6-0 tall by 2-0-0 wide will fit between the bottom chord and any other members.
 - Provide mechanical connection (by others) of truss to bearing plate capable of withstanding 100 lb uplift at joint(s) 2, 10, 15, 16, 13, 12.
 - Beveled plate or shim required to provide full bearing surface with truss chord at joint(s) 2, 10.

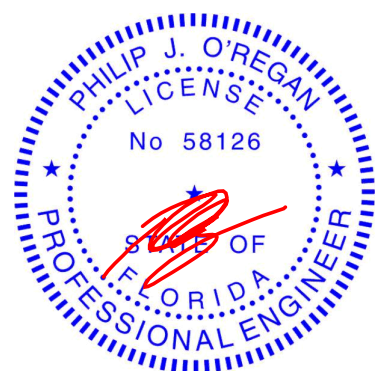

Philip J. O'Regan PE No.58126
MiTek USA, Inc. FL Cert 6634
6904 Parke East Blvd. Tampa FL 33610
Date:

September 7,2021

Job	Truss	Truss Type	Qty	Ply	IC CONST. - LIBERTY RES.	T25256422
2918935	T02	Attic	5	1	Job Reference (optional)	

Builders FirstSource (Lake City, FL), Lake City, FL - 32055,

8.430 s Aug 16 2021 MiTek Industries, Inc. Sat Sep 4 11:23:32 2021 Page 1

ID:b2ldskJGjOxOjHDJp?LTyh2aU-vQi8IbixTLBuZ92wFbzOpvTQrOZmZ4C_W83EbNyh11v

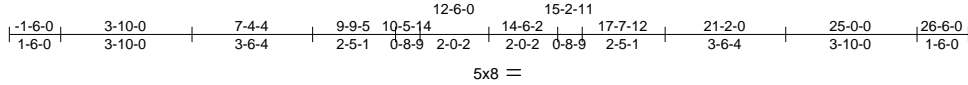

Scale = 1:67.3

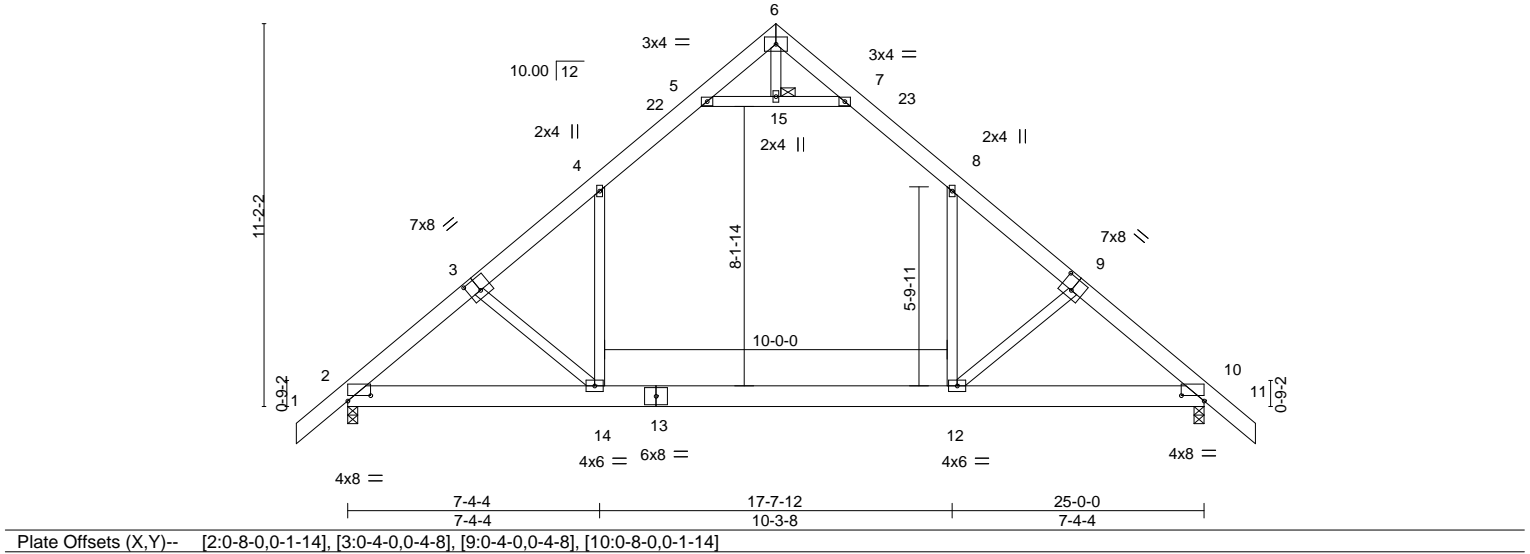

LOADING (psf)	SPACING-	CSI.	DEFL.	PLATES	GRIP
TCLL 20.0	Plate Grip DOL 1.25	TC 0.46	Vert(LL) -0.24 12-14 >999 240	MT20	244/190
TCDL 7.0	Lumber DOL 1.25	BC 0.40	Vert(CT) -0.43 12-14 >697 180		
BCLL 0.0 *	Rep Stress Incr YES	WB 0.48	Horz(CT) 0.01 10 n/a n/a		
BCDL 10.0	Code FBC2020/TPI2014	Matrix-MS	Attic -0.13 12-14 987 360	Weight: 203 lb	FT = 20%

LUMBER-	BRACING-
TOP CHORD 2x6 SP M 26 *Except* 1-3,9-11: 2x6 SP No.2	TOP CHORD Structural wood sheathing directly applied or 5-1-11 oc purlins.
BOT CHORD 2x8 SP 2400F 2.0E	BOT CHORD Rigid ceiling directly applied or 10-0-0 oc bracing.
WEBS 2x4 SP No.3	JOINTS 1 Brace at Jt(s): 15

REACTIONS. (size) 2=0-3-8, 10=0-3-8
 Max Horz 2=-257(LC 10)
 Max Uplift 2=-48(LC 12), 10=-48(LC 13)
 Max Grav 2=1429(LC 20), 10=1429(LC 21)

FORCES. (lb) - Max. Comp./Max. Ten. - All forces 250 (lb) or less except when shown.
 TOP CHORD 2-3=-1978/4, 3-4=-1840/18, 4-5=-1113/107, 5-6=-10/445, 6-7=-10/445, 7-8=-1113/107,
 8-9=-1840/18, 9-10=-1977/4
 BOT CHORD 2-14=46/1630, 12-14=0/1265, 10-12=0/1511
 WEBS 5-15=-1755/92, 7-15=-1755/92, 8-12=0/1007, 9-12=-493/185, 4-14=0/1007,
 3-14=-492/184

- NOTES-**
- Unbalanced roof live loads have been considered for this design.
 - Wind: ASCE 7-16; Vult=130mph (3-second gust) Vasd=101mph; TCDL=4.2psf; BCDL=3.0psf; h=20ft; Cat. II; Exp B; Encl., GCpi=0.18; MWFRS (envelope) gable end zone and C-C Exterior(2E) -1-6-0 to 1-6-0, Interior(1) 1-6-0 to 12-6-0, Exterior(2R) 12-6-0 to 15-6-0, Interior(1) 15-6-0 to 26-6-0 zone; C-C for members and forces & MWFRS for reactions shown; Lumber DOL=1.60 plate grip DOL=1.60
 - Building Designer / Project engineer responsible for verifying applied roof live load shown covers rain loading requirements specific to the use of this truss component.
 - This truss has been designed for a 10.0 psf bottom chord live load nonconcurrent with any other live loads.
 - * This truss has been designed for a live load of 20.0psf on the bottom chord in all areas where a rectangle 3-6-0 tall by 2-0-0 wide will fit between the bottom chord and any other members.
 - Ceiling dead load (5.0 psf) on member(s). 4-5, 7-8, 5-15, 7-15; Wall dead load (5.0psf) on member(s).8-12, 4-14
 - Bottom chord live load (40.0 psf) and additional bottom chord dead load (10.0 psf) applied only to room. 12-14
 - Provide mechanical connection (by others) of truss to bearing plate capable of withstanding 100 lb uplift at joint(s) 2, 10.
 - Attic room checked for L/360 deflection.

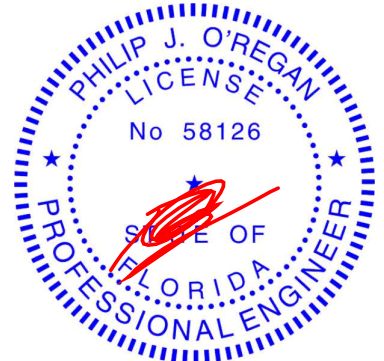

Philip J. O'Regan PE No.58126
 MiTek USA, Inc. FL Cert 6634
 6904 Parke East Blvd. Tampa FL 33610
 Date: September 7, 2021

Job	Truss	Truss Type	Qty	Ply	IC CONST. - LIBERTY RES.	T25256423
2918935	T02G	GABLE	1	1	Job Reference (optional)	

Builders FirstSource (Lake City, FL), Lake City, FL - 32055, 8.430 s Aug 16 2021 MiTek Industries, Inc. Sat Sep 4 11:23:33 2021 Page 1
 ID:b2ldsklJGjOxOjHDJpP?LTyh2aU-NdGXyXjZEfKIBJd6pJUdL6?eUoxYlcc8koo07pyh11u

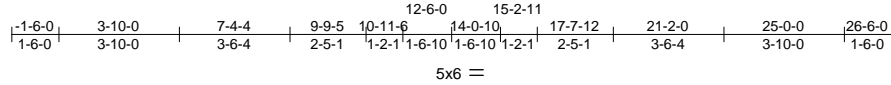

Scale = 1:73.3

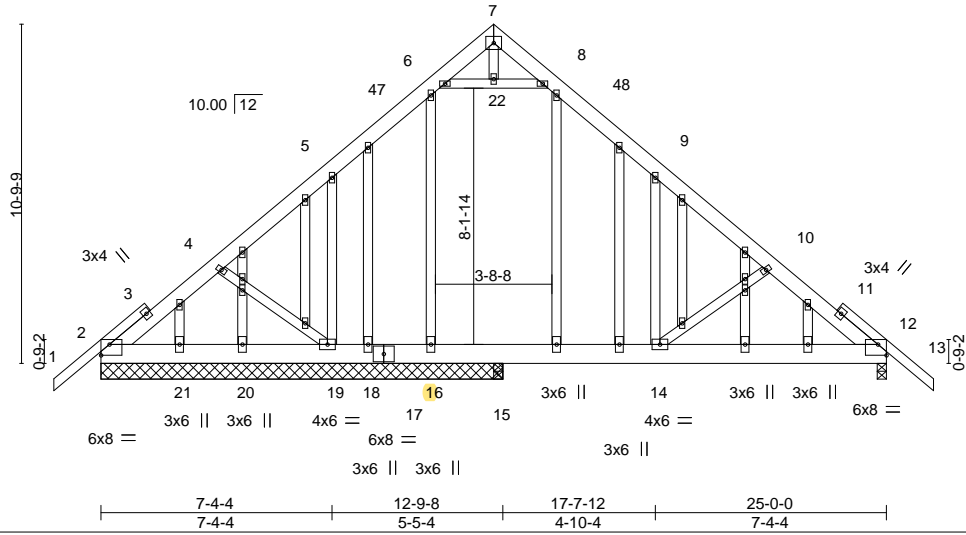

LOADING (psf)	SPACING-	CSI.	DEFL.	PLATES	GRIP
TCLL 20.0	Plate Grip DOL 1.25	TC 0.27	in (loc) l/defl L/d	MT20	244/190
TCDL 7.0	Lumber DOL 1.25	BC 0.30	Vert(LL) -0.07 14-46 >999 240		
BCLL 0.0 *	Rep Stress Incr YES	WB 0.15	Vert(CT) -0.14 14-46 >999 180		
BCDL 10.0	Code FBC2020/TPI2014	Matrix-MS	Horz(CT) -0.01 12 n/a n/a		
			Attic -0.06 14-15 2000 360	Weight: 267 lb	FT = 20%

LUMBER-	BRACING-
TOP CHORD 2x6 SP No.2 *Except* 1-3,11-13: 2x4 SP No.2	TOP CHORD Structural wood sheathing directly applied or 6-0-0 oc purlins.
BOT CHORD 2x8 SP 2400F 2.0E	BOT CHORD Rigid ceiling directly applied or 10-0-0 oc bracing.
WEBS 2x4 SP No.3	
OTHERS 2x4 SP No.3	

REACTIONS. All bearings 12-9-8 except (jt=length) 12=0-3-8, 15=0-3-8.
 (lb) - Max Horz 2=-247(LC 10)
 Max Uplift All uplift 100 lb or less at joint(s) 2, 12, 18, 21 except 19=-203(LC 12), 16=-756(LC 21), 15=-117(LC 13)
 Max Grav All reactions 250 lb or less at joint(s) 16, 20, 21 except 2=607(LC 1), 12=784(LC 1), 19=365(LC 24), 18=507(LC 21), 15=1523(LC 21)

FORCES. (lb) - Max. Comp./Max. Ten. - All forces 250 (lb) or less except when shown.
 TOP CHORD 2-4=-719/81, 4-5=-628/79, 5-6=-505/126, 8-9=-479/105, 9-10=-610/19, 10-12=-748/15
 BOT CHORD 2-21=-7/583, 20-21=-7/583, 19-20=-7/583, 18-19=0/433, 16-18=0/433, 15-16=0/433, 14-15=0/433, 12-14=0/641
 WEBS 6-22=-485/169, 8-22=-485/169, 10-14=-391/170, 5-19=-253/192

- NOTES-**
- Unbalanced roof live loads have been considered for this design.
 - Wind: ASCE 7-16; Vult=130mph (3-second gust) Vasd=101mph; TCCL=4.2psf; BCDL=3.0psf; h=20ft; Cat. II; Exp B; Encl., GCpi=0.18; MWFRS (envelope) gable end zone and C-C Exterior(2E) -1-6-0 to 1-6-0, Interior(1) 1-6-0 to 12-6-0, Exterior(2R) 12-6-0 to 15-6-0, Interior(1) 15-6-0 to 26-6-0 zone; C-C for members and forces & MWFRS for reactions shown; Lumber DOL=1.60 plate grip DOL=1.60
 - Truss designed for wind loads in the plane of the truss only. For studs exposed to wind (normal to the face), see Standard Industry Gable End Details as applicable, or consult qualified building designer as per ANSI/TPI 1.
 - Building Designer / Project engineer responsible for verifying applied roof live load shown covers rain loading requirements specific to the use of this truss component.
 - All plates are 2x4 MT20 unless otherwise indicated.
 - Gable studs spaced at 2-0-0 oc.
 - This truss has been designed for a 10.0 psf bottom chord live load nonconcurrent with any other live loads.
 - * This truss has been designed for a live load of 20.0psf on the bottom chord in all areas where a rectangle 3-6-0 tall by 2-0-0 wide will fit between the bottom chord and any other members.
 - Ceiling dead load (5.0 psf) on member(s). 5-6, 8-9, 6-22, 8-22; Wall dead load (5.0psf) on member(s).9-14, 5-19
 - Bottom chord live load (40.0 psf) and additional bottom chord dead load (10.0 psf) applied only to room. 18-19, 16-18, 15-16, 14-15
 - Provide mechanical connection (by others) of truss to bearing plate capable of withstanding 100 lb uplift at joint(s) 2, 12, 18, 21 except (jt=lb) 19=203, 16=756, 15=117.
 - Attic room checked for L/360 deflection.

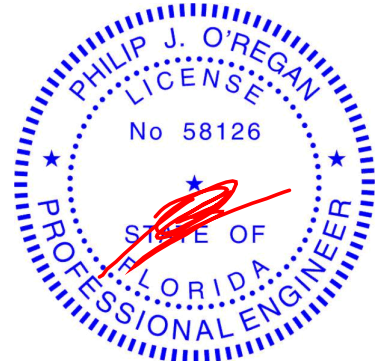

Philip J. O'Regan PE No.58126
 MiTek USA, Inc. FL Cert 6634
 6904 Parke East Blvd. Tampa FL 33610
 Date: September 7, 2021

Job	Truss	Truss Type	Qty	Ply	IC CONST. - LIBERTY RES.	T25256424
2918935	T03	Attic	7	1		

Builders FirstSource (Lake City, FL),

Lake City, FL - 32055,

8.430 s Aug 16 2021 MiTek Industries, Inc. Sat Sep 4 11:23:35 2021 Page 1

ID:b2ldskJGjOxOjHDJpP?LTyh2aU-J?OHNdKpmGaTQdnVxkW5QX4x4bbTmRyRC6HvCiyh11s

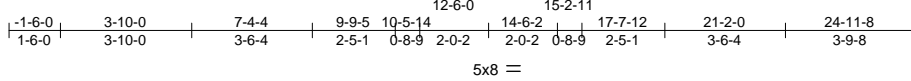

Scale = 1:67.3

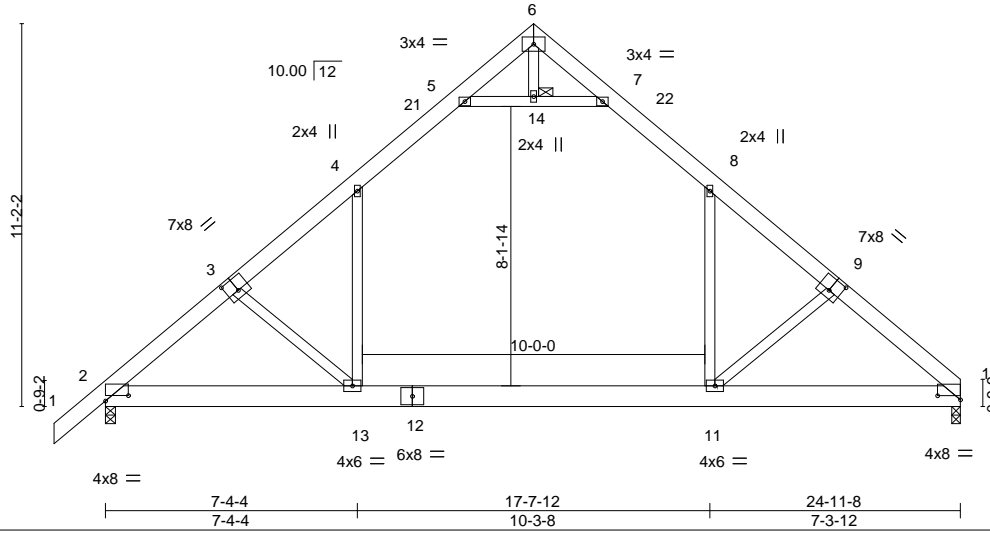

LOADING (psf)	SPACING-	CSI.	DEFL.	in (loc)	l/defl	L/d	PLATES	GRIP
TCLL 20.0	Plate Grip DOL 1.25	TC 0.46	Vert(LL) -0.24	11-13	>999	240	MT20	244/190
TCDL 7.0	Lumber DOL 1.25	BC 0.40	Vert(CT) -0.43	11-13	>696	180		
BCLL 0.0 *	Rep Stress Incr YES	WB 0.48	Horz(CT) 0.01	10	n/a	n/a		
BCDL 10.0	Code FBC2020/TPI2014	Matrix-MS	Attic -0.13	11-13	986	360		
							Weight: 198 lb	FT = 20%

LUMBER-	BRACING-
TOP CHORD 2x6 SP M 26 *Except* 1-3,9-10: 2x6 SP No.2	TOP CHORD Structural wood sheathing directly applied or 5-1-11 oc purlins.
BOT CHORD 2x8 SP 2400F 2.0E	BOT CHORD Rigid ceiling directly applied or 10-0-0 oc bracing.
WEBS 2x4 SP No.3	JOINTS 1 Brace at Jt(s): 14

REACTIONS. (size) 2=0-3-8, 10=0-3-0
 Max Horz 2=248(LC 9)
 Max Uplift 2=-48(LC 12), 10=-14(LC 13)
 Max Grav 2=1428(LC 20), 10=1352(LC 21)

FORCES. (lb) - Max. Comp./Max. Ten. - All forces 250 (lb) or less except when shown.
 TOP CHORD 2-3=-1978/7, 3-4=-1841/21, 4-5=-1113/110, 5-6=-10/444, 6-7=-12/445, 7-8=-1112/108,
 8-9=-1836/20, 9-10=-1973/6
 BOT CHORD 2-13=-65/1615, 11-13=0/1250, 10-11=0/1492
 WEBS 5-14=-1755/100, 7-14=-1755/100, 8-11=0/1002, 9-11=-493/192, 4-13=0/1006,
 3-13=-492/183

- NOTES-**
- Unbalanced roof live loads have been considered for this design.
 - Wind: ASCE 7-16; Vult=130mph (3-second gust) Vasd=101mph; TCDL=4.2psf; BCDL=3.0psf; h=20ft; Cat. II; Exp B; Encl., GCpi=0.18; MWFRS (envelope) gable end zone and C-C Exterior(2E) -1-6-0 to 1-6-0, Interior(1) 1-6-0 to 12-6-0, Exterior(2R) 12-6-0 to 15-6-0, Interior(1) 15-6-0 to 24-11-8 zone; C-C for members and forces & MWFRS for reactions shown; Lumber DOL=1.60 plate grip DOL=1.60
 - Building Designer / Project engineer responsible for verifying applied roof live load shown covers rain loading requirements specific to the use of this truss component.
 - This truss has been designed for a 10.0 psf bottom chord live load nonconcurrent with any other live loads.
 - * This truss has been designed for a live load of 20.0psf on the bottom chord in all areas where a rectangle 3-6-0 tall by 2-0-0 wide will fit between the bottom chord and any other members.
 - Ceiling dead load (5.0 psf) on member(s). 4-5, 7-8, 5-14, 7-14; Wall dead load (5.0psf) on member(s).8-11, 4-13
 - Bottom chord live load (40.0 psf) and additional bottom chord dead load (10.0 psf) applied only to room. 11-13
 - Provide mechanical connection (by others) of truss to bearing plate capable of withstanding 100 lb uplift at joint(s) 2, 10.
 - Attic room checked for L/360 deflection.

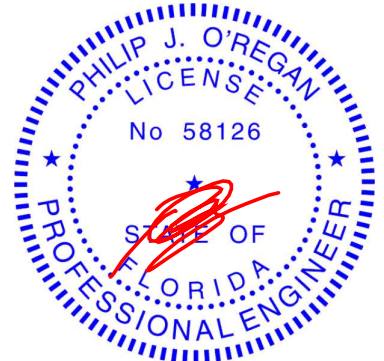

Philip J. O'Regan PE No.58126
 MiTek USA, Inc. FL Cert 6634
 6904 Parke East Blvd. Tampa FL 33610
 Date: September 7, 2021

Job	Truss	Truss Type	Qty	Ply	IC CONST. - LIBERTY RES.	T25256425
2918935	T04	Attic Girder	1	2	Job Reference (optional)	

Builders FirstSource (Lake City, FL), Lake City, FL - 32055,

8.430 s Aug 16 2021 MiTek Industries, Inc. Sat Sep 4 11:23:36 2021 Page 1

ID:b2ldskJGjOxOjHDJpp?LTyh2aU-oCfyaylRXaik2nMhUR2Kzld5A?xuVu0aQm1Sk8yh11r

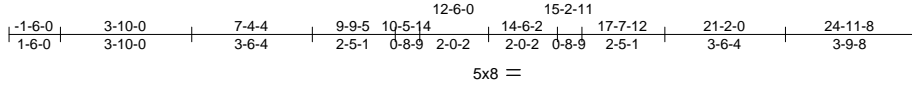

Scale = 1:67.3

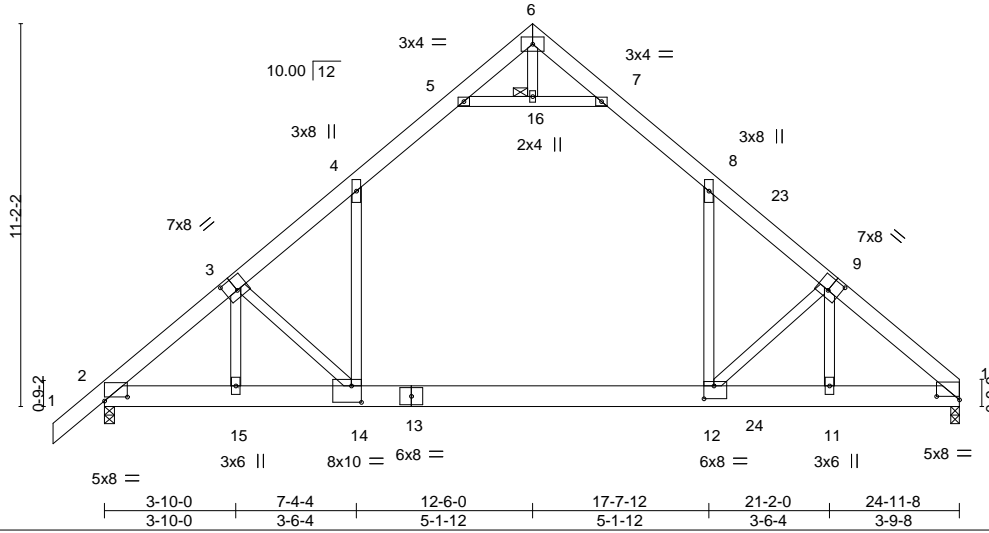

Plate Offsets (X,Y)-- [2:0-8-0,0-1-6], [3:0-4-0,0-4-8], [9:0-4-0,0-4-8], [10:0-8-0,0-1-3], [12:0-3-8,0-4-8], [14:0-3-8,0-5-12]

LOADING (psf)	SPACING-	CSI.	DEFL.	PLATES	GRIP
TCLL 20.0	2-0-0	TC 0.57	in (loc) l/defl L/d	MT20	244/190
TCDL 7.0	Plate Grip DOL 1.25	BC 0.39	Vert(LL) -0.25 12-14 >999 240		
BCLL 0.0 *	Lumber DOL 1.25	WB 0.49	Vert(CT) -0.44 12-14 >688 180		
BCDL 10.0	Rep Stress Incr NO	Matrix-MS	Horz(CT) 0.01 10 n/a n/a		
	Code FBC2020/TP12014		Attic -0.10 12-14 1288 360	Weight: 413 lb	FT = 20%

LUMBER-

TOP CHORD 2x6 SP M 26 *Except*
1-3,9-10: 2x6 SP No.2
BOT CHORD 2x8 SP 2400F 2.0E
WEBS 2x4 SP No.3

BRACING-

TOP CHORD Structural wood sheathing directly applied or 6-0-0 oc purlins.
BOT CHORD Rigid ceiling directly applied or 10-0-0 oc bracing.
JOINTS 1 Brace at Jt(s): 16

REACTIONS.

(size) 2=0-3-8, 10=0-3-0
Max Horz 2=266(LC 7)
Max Uplift 2=-320(LC 8), 10=-301(LC 9)
Max Grav 2=3036(LC 34), 10=3101(LC 35)

FORCES. (lb) - Max. Comp./Max. Ten. - All forces 250 (lb) or less except when shown.

TOP CHORD 2-3=-4070/404, 3-4=-4487/446, 4-5=-2903/363, 5-6=-175/943, 6-7=-178/962,
7-8=-2884/360, 8-9=-4515/433, 9-10=-4306/453
BOT CHORD 2-15=-389/3321, 14-15=-390/3297, 12-14=-171/3035, 11-12=-304/3333, 10-11=-299/3347
WEBS 8-12=-281/2247, 9-12=-630/386, 9-11=-719/139, 4-14=-295/2309, 3-14=-414/296,
3-15=-925/139, 5-16=-4316/649, 7-16=-4316/649

NOTES-

- 2-ply truss to be connected together with 10d (0.131"x3") nails as follows:
Top chords connected as follows: 2x6 - 2 rows staggered at 0-9-0 oc.
Bottom chords connected as follows: 2x8 - 2 rows staggered at 0-9-0 oc.
Webs connected as follows: 2x4 - 1 row at 0-9-0 oc.
- All loads are considered equally applied to all plies, except if noted as front (F) or back (B) face in the LOAD CASE(S) section. Ply to ply connections have been provided to distribute only loads noted as (F) or (B), unless otherwise indicated.
- Unbalanced roof live loads have been considered for this design.
- Wind: ASCE 7-16; Vult=130mph (3-second gust) Vasd=101mph; TCDL=4.2psf; BCDL=3.0psf; h=20ft; Cat. II; Exp B; Encl., GCpi=0.18; MWFRS (envelope) gable end zone; Lumber DOL=1.60 plate grip DOL=1.60
- Building Designer / Project engineer responsible for verifying applied roof live load shown covers rain loading requirements specific to the use of this truss component.
- This truss has been designed for a 10.0 psf bottom chord live load nonconcurrent with any other live loads.
- * This truss has been designed for a live load of 20.0psf on the bottom chord in all areas where a rectangle 3-6-0 tall by 2-0-0 wide will fit between the bottom chord and any other members.
- Ceiling dead load (5.0 psf) on member(s). 4-5, 7-8, 5-16, 7-16; Wall dead load (5.0psf) on member(s).8-12, 4-14
- Bottom chord live load (40.0 psf) and additional bottom chord dead load (10.0 psf) applied only to room. 12-14
- Provide mechanical connection (by others) of truss to bearing plate capable of withstanding 100 lb uplift at joint(s) except (jt=lb) 2=320, 10=301.
- Girder carries tie-in span(s): 5-0-0 from 7-0-12 to 18-10-12; 5-0-0 from 7-0-12 to 18-10-12
- Hanger(s) or other connection device(s) shall be provided sufficient to support concentrated load(s) 354 lb down and 207 lb up at 7-0-12, and 317 lb down and 205 lb up at 18-10-12 on bottom chord. The design/selection of such connection device(s) is the responsibility of others.

13) Attic room checked for L/360 deflection.

Continued on page 2



Philip J. O'Regan PE No.58126
MiTek USA, Inc. FL Cert 6634
6904 Parke East Blvd. Tampa FL 33610
Date:

September 7, 2021

WARNING - Verify design parameters and READ NOTES ON THIS AND INCLUDED MITEK REFERENCE PAGE MII-7473 rev. 5/19/2020 BEFORE USE.

Design valid for use only with MiTek® connectors. This design is based only upon parameters shown, and is for an individual building component, not a truss system. Before use, the building designer must verify the applicability of design parameters and properly incorporate this design into the overall building design. Bracing indicated is to prevent buckling of individual truss web and/or chord members only. Additional temporary and permanent bracing is always required for stability and to prevent collapse with possible personal injury and property damage. For general guidance regarding the fabrication, storage, delivery, erection and bracing of trusses and truss systems, see ANSIT/TP1 Quality Criteria, DSB-89 and BCSI Building Component Safety Information available from Truss Plate Institute, 2670 Crain Highway, Suite 203 Waldorf, MD 20601



6904 Parke East Blvd.
Tampa, FL 33610

Job	Truss	Truss Type	Qty	Ply	IC CONST. - LIBERTY RES.	T25256425
2918935	T04	Attic Girder	1	2	Job Reference (optional)	

Builders FirstSource (Lake City,FL), Lake City, FL - 32055,

8.430 s Aug 16 2021 MiTek Industries, Inc. Sat Sep 4 11:23:36 2021 Page 2
ID:b2ldskJGjOxOjHDJPP?LTyh2aU-oCyfaylRXaik2nMhUR2Kzld5A?xuVu0aQm1Sk8yh11r

LOAD CASE(S) Standard

1) Dead + Roof Live (balanced): Lumber Increase=1.25, Plate Increase=1.25

Uniform Loads (plf)

Vert: 1-4=-54, 4-5=-134(F=-71), 5-6=-125(F=-71), 6-7=-125(F=-70), 7-8=-134(F=-70), 8-23=-125(F=-70), 10-23=-54, 14-17=-20, 12-14=-111(F=-71),
12-24=-90(F=-71), 20-24=-20, 5-7=-10

Drag: 8-12=-10, 4-14=-10

Concentrated Loads (lb)

Vert: 14=-326(F) 24=-317(F)

WARNING - Verify design parameters and READ NOTES ON THIS AND INCLUDED MITEK REFERENCE PAGE MII-7473 rev. 5/19/2020 BEFORE USE.

Design valid for use only with MiTek® connectors. This design is based only upon parameters shown, and is for an individual building component, not a truss system. Before use, the building designer must verify the applicability of design parameters and properly incorporate this design into the overall building design. Bracing indicated is to prevent buckling of individual truss web and/or chord members only. Additional temporary and permanent bracing is always required for stability and to prevent collapse with possible personal injury and property damage. For general guidance regarding the fabrication, storage, delivery, erection and bracing of trusses and truss systems, see **ANSI/TPI1 Quality Criteria, DSB-89 and BCSI Building Component Safety Information** available from Truss Plate Institute, 2670 Crain Highway, Suite 203 Waldorf, MD 20601



6904 Parke East Blvd.
Tampa, FL 36610

Job	Truss	Truss Type	Qty	Ply	IC CONST. - LIBERTY RES.	T25256427
2918935	T05G	GABLE	1	1		

Builders FirstSource (Lake City,FL), Lake City, FL - 32055, 8.430 s Aug 16 2021 MiTek Industries, Inc. Sat Sep 4 11:23:40 2021 Page 1
 ID:b2ldskJGjOxOjHDJPP?LTyh2aU-gzBAQKoyaoCIXOfSjH6G7bor_cN9RmYALO?ftvyh11n

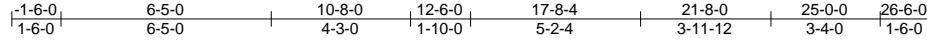

4x4 =

Scale = 1:70.3

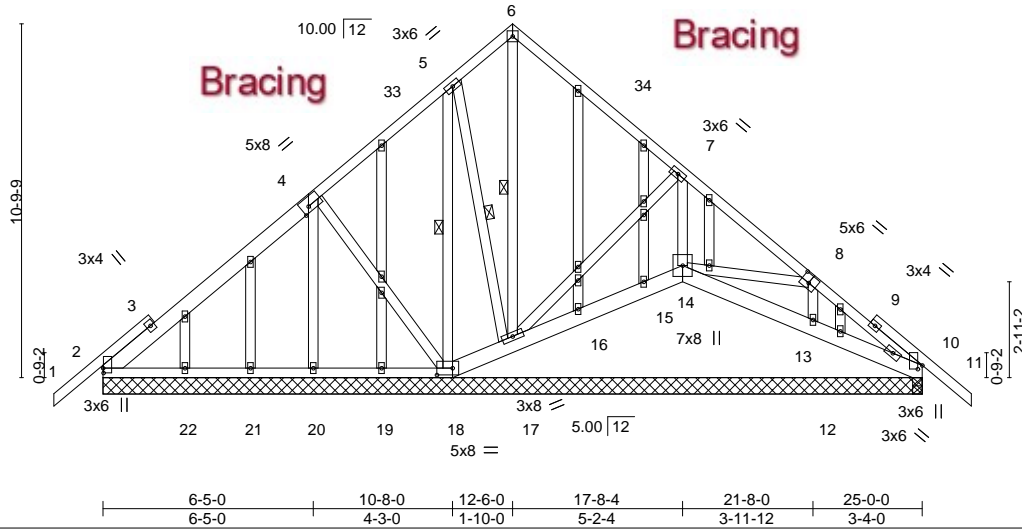

Job 2918935	Truss T06	Truss Type Common	Qty 4	Ply 1	IC CONST. - LIBERTY RES. Job Reference (optional)	T25256428
----------------	--------------	----------------------	----------	----------	--	-----------

Builders FirstSource (Lake City,FL), Lake City, FL - 32055,

8.430 s Aug 16 2021 MiTek Industries, Inc. Sat Sep 4 11:23:41 2021 Page 1

ID:b2ldskJGjOxOjHDJPP?LTyh2aU-89iYegpaL6Kc8YEeH_dVgoK?o0d0A8rJa2kDPLyh11m



4x4 =

Scale = 1:66.7

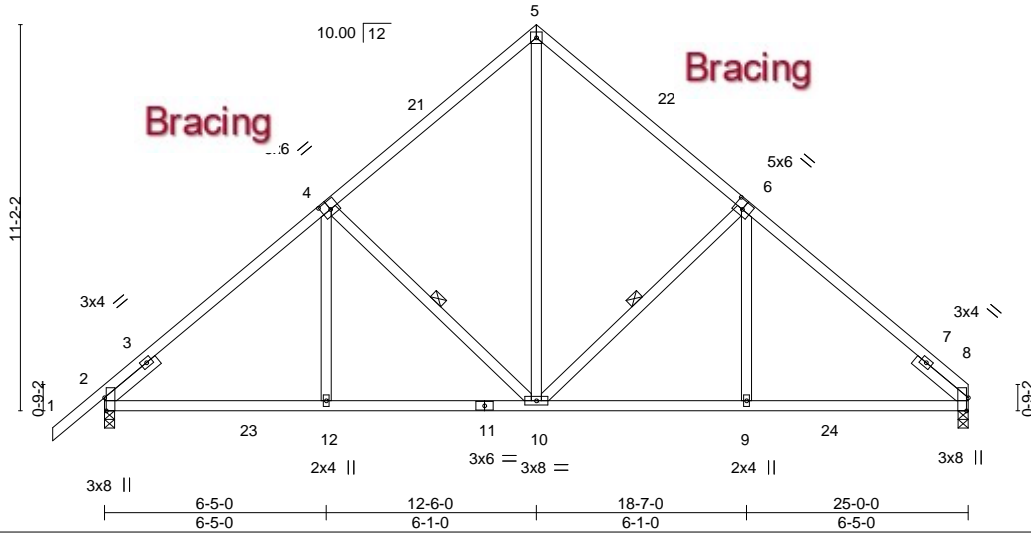

Plate Offsets (X,Y)-- [2:0-4-9,Edge], [4:0-3-0,0-3-0], [6:0-3-0,0-3-0], [8:0-4-9,Edge]

LOADING (psf)	SPACING-	CSI.	DEFL.	PLATES	GRIP
TCLL 20.0	2-0-0	TC 0.38	in (loc) l/defl L/d	MT20	244/190
TCDL 7.0	Plate Grip DOL 1.25	BC 0.46	Vert(LL) -0.05 10-12 >999 240		
BCLL 0.0 *	Lumber DOL 1.25	WB 0.45	Vert(CT) -0.10 10-12 >999 180		
BCDL 10.0	Rep Stress Incr YES	Matrix-MS	Horz(CT) 0.03 8 n/a n/a		
	Code FBC2020/TPI2014			Weight: 151 lb	FT = 20%

LUMBER-

TOP CHORD 2x4 SP No.2
 BOT CHORD 2x4 SP No.2
 WEBS 2x4 SP No.3
 SLIDER Left 2x4 SP No.3 1-11-8, Right 2x4 SP No.3 1-11-8

BRACING-

TOP CHORD Structural wood sheathing directly applied or 5-1-5 oc purlins.
 BOT CHORD Rigid ceiling directly applied or 10-0-0 oc bracing.
 WEBS 1 Row at midpt 6-10, 4-10

REACTIONS.

(size) 2=0-3-8, 8=0-3-8
 Max Horz 2=248(LC 9)
 Max Uplift 2=-202(LC 12), 8=-168(LC 13)
 Max Grav 2=1125(LC 19), 8=1047(LC 20)

FORCES. (lb) - Max. Comp./Max. Ten. - All forces 250 (lb) or less except when shown.

TOP CHORD 2-4=-1237/231, 4-5=-908/266, 5-6=-908/266, 6-8=-1239/238
 BOT CHORD 2-12=-214/1037, 10-12=-215/1036, 9-10=-106/918, 8-9=-106/920
 WEBS 5-10=-201/767, 6-10=-491/255, 6-9=0/282, 4-10=-480/249, 4-12=0/280

NOTES-

- Unbalanced roof live loads have been considered for this design.
- Wind: ASCE 7-16; Vult=130mph (3-second gust) Vasd=101mph; TC DL=4.2psf; BCDL=3.0psf; h=20ft; Cat. II; Exp B; Encl., GCpi=0.18; MWFRS (envelope) gable end zone and C-C Exterior(2E) -1-6-0 to 1-6-0, Interior(1) 1-6-0 to 12-6-0, Exterior(2R) 12-6-0 to 15-6-0, Interior(1) 15-6-0 to 25-0-0 zone; C-C for members and forces & MWFRS for reactions shown; Lumber DOL=1.60 plate grip DOL=1.60
- Building Designer / Project engineer responsible for verifying applied roof live load shown covers rain loading requirements specific to the use of this truss component.
- This truss has been designed for a 10.0 psf bottom chord live load nonconcurrent with any other live loads.
- * This truss has been designed for a live load of 20.0psf on the bottom chord in all areas where a rectangle 3-6-0 tall by 2-0-0 wide will fit between the bottom chord and any other members, with BCDL = 10.0psf.
- Provide mechanical connection (by others) of truss to bearing plate capable of withstanding 100 lb uplift at joint(s) except (jt=lb) 2=202, 8=168.

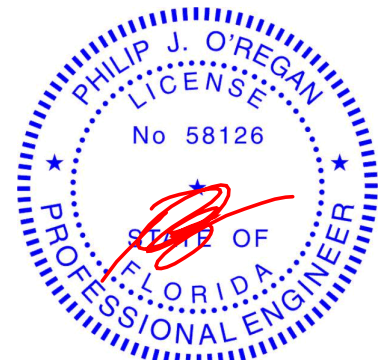

Philip J. O'Regan PE No.58126
 MiTek USA, Inc. FL Cert 6634
 6904 Parke East Blvd. Tampa FL 33610
 Date:

September 7, 2021

WARNING - Verify design parameters and READ NOTES ON THIS AND INCLUDED MITEK REFERENCE PAGE MII-7473 rev. 5/19/2020 BEFORE USE.

Design valid for use only with MiTek® connectors. This design is based only upon parameters shown, and is for an individual building component, not a truss system. Before use, the building designer must verify the applicability of design parameters and properly incorporate this design into the overall building design. Bracing indicated is to prevent buckling of individual truss web and/or chord members only. Additional temporary and permanent bracing is always required for stability and to prevent collapse with possible personal injury and property damage. For general guidance regarding the fabrication, storage, delivery, erection and bracing of trusses and truss systems, see

ANSI/TPI1 Quality Criteria, DSB-89 and BCSI Building Component

Safety Information available from Truss Plate Institute, 2670 Crain Highway, Suite 203 Waldorf, MD 20601



6904 Parke East Blvd.
 Tampa, FL 33610

Job	Truss	Truss Type	Qty	Ply	IC CONST. - LIBERTY RES.	T25256429
2918935	T07	Common	2	1	Job Reference (optional)	

Builders FirstSource (Lake City,FL), Lake City, FL - 32055, 8.430 s Aug 16 2021 MiTek Industries, Inc. Sat Sep 4 11:23:42 2021 Page 1
 ID:b2ldsklJGjOxOjHDJpp?LTyh2aU-clJwr0qC6QSTmpirri9kC0tAdQzGvb6TpiUmyoyh11

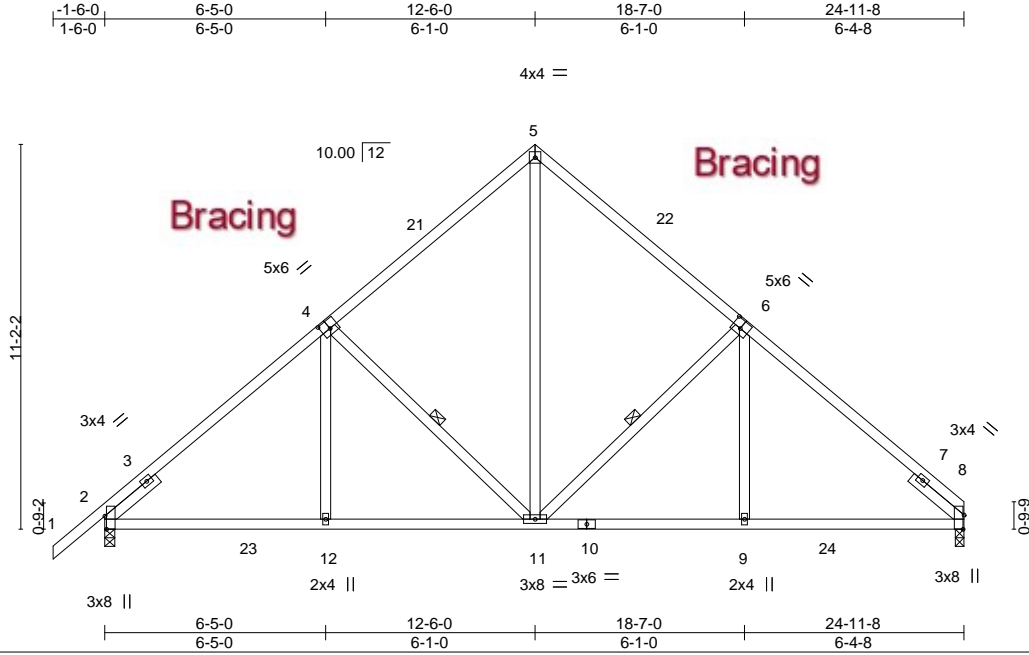

Scale = 1:66.9

Plate Offsets (X,Y)-- [2:0-4-9,Edge], [4:0-3-0,0-3-0], [6:0-3-0,0-3-0], [8:0-5-0,Edge]

LOADING (psf)	SPACING-	CSI.	DEFL.	PLATES	GRIP
TCLL 20.0	2-0-0	TC 0.38	in (loc) l/defl L/d	MT20	244/190
TCDL 7.0	Plate Grip DOL 1.25	BC 0.46	Vert(LL) -0.05 11-12 >999 240		
BCLL 0.0 *	Lumber DOL 1.25	WB 0.45	Vert(CT) -0.10 11-12 >999 180		
BCDL 10.0	Rep Stress Incr YES	Matrix-MS	Horz(CT) 0.03 8 n/a n/a		
	Code FBC2020/TPI2014			Weight: 151 lb	FT = 20%

LUMBER-	BRACING-
TOP CHORD 2x4 SP No.2	TOP CHORD Structural wood sheathing directly applied or 5-1-6 oc purlins.
BOT CHORD 2x4 SP No.2	BOT CHORD Rigid ceiling directly applied or 10-0-0 oc bracing.
WEBS 2x4 SP No.3	WEBS 1 Row at midpt 4-11, 6-11
SLIDER Left 2x4 SP No.3 1-11-8, Right 2x4 SP No.3 1-11-8	

REACTIONS. (size) 2=0-3-8, 8=0-3-0
 Max Horz 2=248(LC 9)
 Max Uplift 2=201(LC 12), 8=168(LC 13)
 Max Grav 2=1123(LC 19), 8=1045(LC 20)

FORCES. (lb) - Max. Comp./Max. Ten. - All forces 250 (lb) or less except when shown.
 TOP CHORD 2-4=-1235/231, 4-5=-906/265, 5-6=-905/265, 6-8=-1232/237
 BOT CHORD 2-12=-215/1035, 11-12=-215/1034, 9-11=-106/911, 8-9=-105/912
 WEBS 4-12=0/280, 4-11=-480/249, 5-11=-200/763, 6-11=-483/254, 6-9=0/278

- NOTES-**
- 1) Unbalanced roof live loads have been considered for this design.
 - 2) Wind: ASCE 7-16; Vult=130mph (3-second gust) Vasd=101mph; TC DL=4.2psf; BCDL=3.0psf; h=20ft; Cat. II; Exp B; Encl., GCpi=0.18; MWFRS (envelope) gable end zone and C-C Exterior(2E) -1-6-0 to 1-6-0, Interior(1) 1-6-0 to 12-6-0, Exterior(2R) 12-6-0 to 15-6-0, Interior(1) 15-6-0 to 24-11-8 zone; C-C for members and forces & MWFRS for reactions shown; Lumber DOL=1.60 plate grip DOL=1.60
 - 3) Building Designer / Project engineer responsible for verifying applied roof live load shown covers rain loading requirements specific to the use of this truss component.
 - 4) This truss has been designed for a 10.0 psf bottom chord live load nonconcurrent with any other live loads.
 - 5) * This truss has been designed for a live load of 20.0psf on the bottom chord in all areas where a rectangle 3-6-0 tall by 2-0-0 wide will fit between the bottom chord and any other members, with BCDL = 10.0psf.
 - 6) Provide mechanical connection (by others) of truss to bearing plate capable of withstanding 100 lb uplift at joint(s) except (jt=lb) 2=201, 8=168.

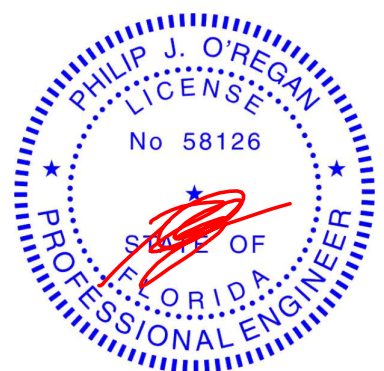

Philip J. O'Regan PE No.58126
 MiTek USA, Inc. FL Cert 6634
 6904 Parke East Blvd. Tampa FL 33610
 Date: September 7, 2021

Job	Truss	Truss Type	Qty	Ply	IC CONST. - LIBERTY RES.	T25256430
2918935	T08	Common	1	2	Job Reference (optional)	

Builders FirstSource (Lake City, FL), Lake City, FL - 32055, 8.430 s Aug 16 2021 MiTek Industries, Inc. Sat Sep 4 11:23:43 2021 Page 1
 ID:b2ldskJGjOxOjHDJPP?LTyh2aU-4YtI2MqqtjaKO1PPgzIDQNnqL5e5sc1MDKU Eyh11k

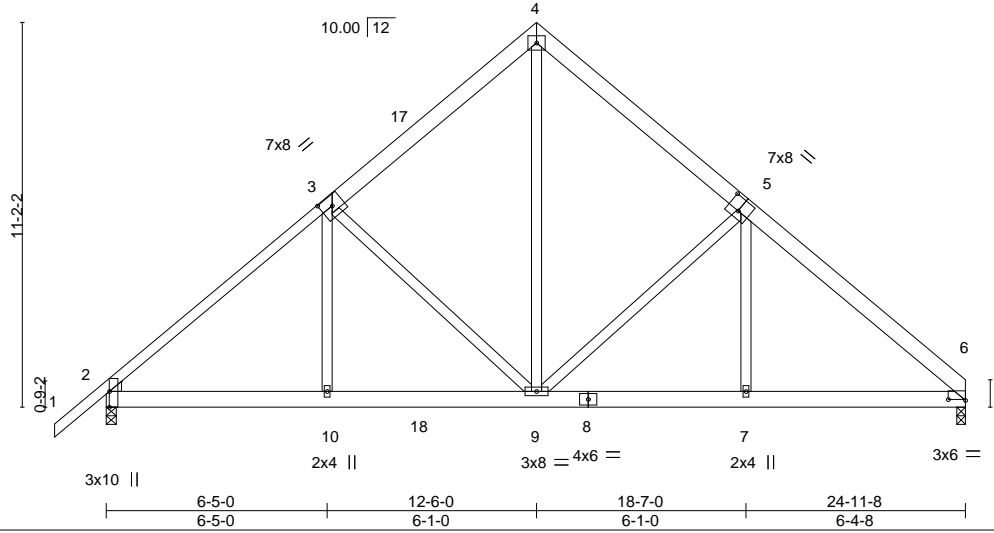
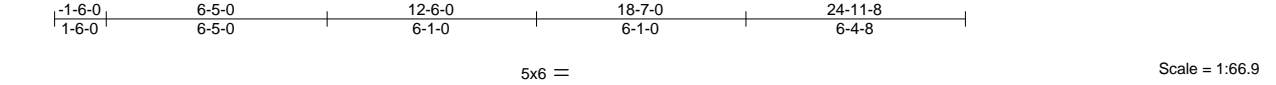

Plate Offsets (X,Y)-- [2:0-5-8,Edge], [3:0-4-0,0-3-4], [5:0-4-0,0-4-8], [6:0-6-0,0-0-5]

LOADING (psf)	SPACING-	CSI.	DEFL.	PLATES	GRIP
TCLL 20.0	2-0-0	TC 0.22	in (loc) l/defl L/d	MT20	244/190
TCDL 7.0	Plate Grip DOL 1.25	BC 0.27	Vert(LL) -0.03 9-10 >999 240		
BCLL 0.0 *	Lumber DOL 1.25	WB 0.29	Vert(CT) -0.06 9-10 >999 180		
BCDL 10.0	Rep Stress Incr NO	Matrix-MS	Horz(CT) 0.02 6 n/a n/a		
	Code FBC2020/TP12014			Weight: 373 lb	FT = 20%

LUMBER-

TOP CHORD 2x6 SP No.2 *Except*
 1-3: 2x4 SP No.2
 BOT CHORD 2x6 SP No.2
 WEBS 2x4 SP No.3
 WEDGE
 Left: 2x4 SP No.3

BRACING-

TOP CHORD Structural wood sheathing directly applied or 6-0-0 oc purlins.
 BOT CHORD Rigid ceiling directly applied or 10-0-0 oc bracing.

REACTIONS.

(size) 2=0-3-8, 6=0-3-0
 Max Horz 2=-412(LC 4)
 Max Uplift 2=-381(LC 8), 6=-449(LC 9)
 Max Grav 2=1573(LC 1), 6=2149(LC 16)

FORCES. (lb) - Max. Comp./Max. Ten. - All forces 250 (lb) or less except when shown.

TOP CHORD 2-3=-1967/484, 3-4=-1695/558, 4-5=-1788/560, 5-6=-2611/574
 BOT CHORD 2-10=-213/1462, 9-10=-213/1459, 7-9=-285/1844, 6-7=-286/1851
 WEBS 3-9=-395/254, 4-9=-483/1411, 5-9=-1077/502, 5-7=-109/524

NOTES-

- 2-ply truss to be connected together with 10d (0.131"x3") nails as follows:
 Top chords connected as follows: 2x4 - 1 row at 0-9-0 oc, 2x6 - 2 rows staggered at 0-9-0 oc.
 Bottom chords connected as follows: 2x6 - 2 rows staggered at 0-9-0 oc.
 Webs connected as follows: 2x4 - 1 row at 0-9-0 oc.
- All loads are considered equally applied to all plies, except if noted as front (F) or back (B) face in the LOAD CASE(S) section. Ply to ply connections have been provided to distribute only loads noted as (F) or (B), unless otherwise indicated.
- Unbalanced roof live loads have been considered for this design.
- Wind: ASCE 7-16; Vult=130mph (3-second gust) Vasd=101mph; TCDL=4.2psf; BCDL=3.0psf; h=20ft; Cat. II; Exp B; Encl., GCpi=0.18; MWFRS (envelope) gable end zone; Lumber DOL=1.60 plate grip DOL=1.60
- Building Designer / Project engineer responsible for verifying applied roof live load shown covers rain loading requirements specific to the use of this truss component.
- This truss has been designed for a 10.0 psf bottom chord live load nonconcurrent with any other live loads.
- * This truss has been designed for a live load of 20.0psf on the bottom chord in all areas where a rectangle 3-6-0 tall by 2-0-0 wide will fit between the bottom chord and any other members.
- Provide mechanical connection (by others) of truss to bearing plate capable of withstanding 100 lb uplift at joint(s) except (jt=lb) 2=381, 6=449.
- Girder carries tie-in span(s): 5-0-0 from 9-0-0 to 24-11-8; 5-0-0 from 9-0-0 to 24-11-8

LOAD CASE(S) Standard

- Dead + Roof Live (balanced): Lumber Increase=1.25, Plate Increase=1.25

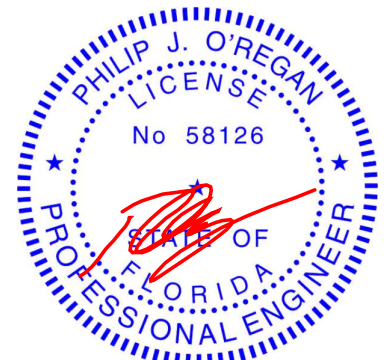

Philip J. O'Regan PE No.58126
 MiTek USA, Inc. FL Cert 6634
 6904 Parke East Blvd. Tampa FL 33610
 Date:

September 7, 2021

Continued on page 2

WARNING - Verify design parameters and READ NOTES ON THIS AND INCLUDED MITEK REFERENCE PAGE MII-7473 rev. 5/19/2020 BEFORE USE.
 Design valid for use only with MiTek® connectors. This design is based only upon parameters shown, and is for an individual building component, not a truss system. Before use, the building designer must verify the applicability of design parameters and properly incorporate this design into the overall building design. Bracing indicated is to prevent buckling of individual truss web and/or chord members only. Additional temporary and permanent bracing is always required for stability and to prevent collapse with possible personal injury and property damage. For general guidance regarding the fabrication, storage, delivery, erection and bracing of trusses and truss systems, see ANSIT/TP1 Quality Criteria, DSB-89 and BCSI Building Component Safety Information available from Truss Plate Institute, 2670 Crain Highway, Suite 203 Waldorf, MD 20601



Job	Truss	Truss Type	Qty	Ply	IC CONST. - LIBERTY RES.	T25256430
2918935	T08	Common	1	2	Job Reference (optional)	

Builders FirstSource (Lake City,FL), Lake City, FL - 32055,

8.430 s Aug 16 2021 MiTek Industries, Inc. Sat Sep 4 11:23:43 2021 Page 2
 ID:b2ldskIJGjOxOjHDJPP?LTyh2aU-4YtI2MqqtjaKO1PPgzlDQnNqLSe5sc1MDKUEyh11k

LOAD CASE(S) Standard

Uniform Loads (plf)

Vert: 1-17=-54, 4-17=-110(F=-55), 4-6=-109(F=-56), 11-18=-20, 14-18=-75(F=-56)

WARNING - Verify design parameters and READ NOTES ON THIS AND INCLUDED MITEK REFERENCE PAGE MII-7473 rev. 5/19/2020 BEFORE USE.

Design valid for use only with MiTek® connectors. This design is based only upon parameters shown, and is for an individual building component, not a truss system. Before use, the building designer must verify the applicability of design parameters and properly incorporate this design into the overall building design. Bracing indicated is to prevent buckling of individual truss web and/or chord members only. Additional temporary and permanent bracing is always required for stability and to prevent collapse with possible personal injury and property damage. For general guidance regarding the fabrication, storage, delivery, erection and bracing of trusses and truss systems, see **ANSI/TPI1 Quality Criteria, DSB-89 and BCSI Building Component Safety Information** available from Truss Plate Institute, 2670 Crain Highway, Suite 203 Waldorf, MD 20601



6904 Parke East Blvd.
Tampa, FL 36610

Job	Truss	Truss Type	Qty	Ply	IC CONST. - LIBERTY RES.	T25256431
2918935	T09	Monopitch	2	1	Job Reference (optional)	

Builders FirstSource (Lake City,FL), Lake City, FL - 32055,

8.430 s Aug 16 2021 MiTek Industries, Inc. Sat Sep 4 11:23:44 2021 Page 1

ID:b2ldskJGjOxOjHDJpp?LTyh2aU-ZkQhGirSe1B??zDy7BCIRyUtDdSNa_IG0zt0gh11j

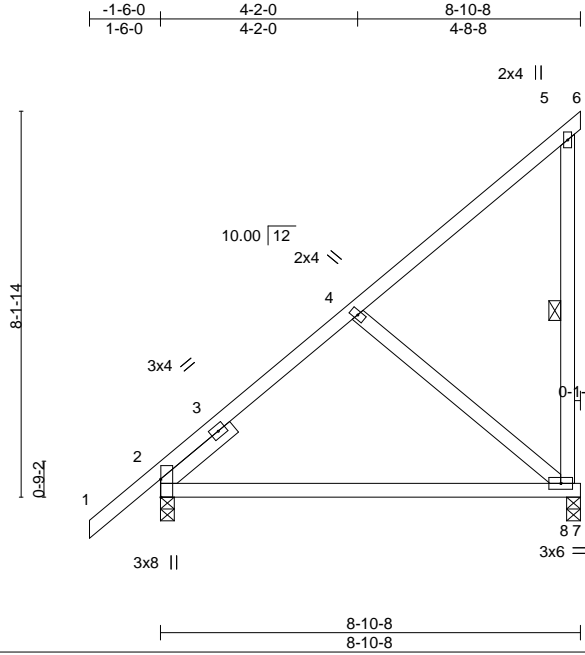

Scale = 1:48.7

Plate Offsets (X,Y)-- [2:0-4-9,Edge]

LOADING (psf)	SPACING-	CSI.	DEFL.	PLATES	GRIP
TCLL 20.0	2-0-0	TC 0.46	in (loc) l/defl L/d	MT20	244/190
TCDL 7.0	Plate Grip DOL 1.25	BC 0.54	Vert(LL) -0.14 8-11 >762 240		
BCLL 0.0 *	Lumber DOL 1.25	WB 0.17	Vert(CT) -0.27 8-11 >384 180		
BCDL 10.0	Rep Stress Incr YES	Matrix-MS	Horz(CT) 0.02 2 n/a n/a		
	Code FBC2020/TPI2014			Weight: 56 lb	FT = 20%

LUMBER-

TOP CHORD 2x4 SP No.2
 BOT CHORD 2x4 SP No.2
 WEBS 2x4 SP No.3
 SLIDER Left 2x4 SP No.3 1-11-8

BRACING-

TOP CHORD Structural wood sheathing directly applied or 6-0-0 oc purlins, except end verticals.
 BOT CHORD Rigid ceiling directly applied or 10-0-0 oc bracing.
 WEBS 1 Row at midpt 5-8

REACTIONS.

(size) 2=0-3-8, 8=0-3-8
 Max Horz 2=290(LC 12)
 Max Uplift 8=208(LC 12)
 Max Grav 2=406(LC 1), 8=352(LC 19)

FORCES. (lb) - Max. Comp./Max. Ten. - All forces 250 (lb) or less except when shown.

TOP CHORD 2-4=-699/0
 WEBS 4-8=-259/246

NOTES-

- 1) Wind: ASCE 7-16; Vult=130mph (3-second gust) Vasd=101mph; TCCL=4.2psf; BCDL=3.0psf; h=20ft; Cat. II; Exp B; Encl., GCpi=0.18; MWFRS (envelope) gable end zone and C-C Exterior(2E) -1-6-0 to 1-6-0, Interior(1) 1-6-0 to 8-10-8 zone; end vertical left exposed; C-C for members and forces & MWFRS for reactions shown; Lumber DOL=1.60 plate grip DOL=1.60
- 2) Building Designer / Project engineer responsible for verifying applied roof live load shown covers rain loading requirements specific to the use of this truss component.
- 3) This truss has been designed for a 10.0 psf bottom chord live load nonconcurrent with any other live loads.
- 4) * This truss has been designed for a live load of 20.0psf on the bottom chord in all areas where a rectangle 3-6-0 tall by 2-0-0 wide will fit between the bottom chord and any other members.
- 5) Provide mechanical connection (by others) of truss to bearing plate capable of withstanding 100 lb uplift at joint(s) except (jt=lb) 8=208.

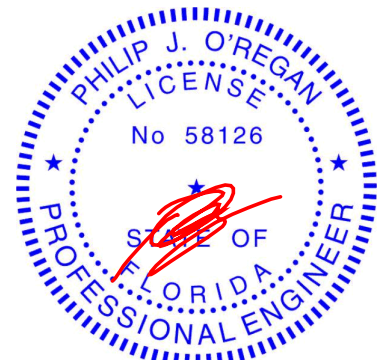

Philip J. O'Regan PE No.58126
 MiTek USA, Inc. FL Cert 6634
 6904 Parke East Blvd. Tampa FL 33610
 Date:

September 7, 2021

WARNING - Verify design parameters and READ NOTES ON THIS AND INCLUDED MITEK REFERENCE PAGE MII-7473 rev. 5/19/2020 BEFORE USE.

Design valid for use only with MiTek® connectors. This design is based only upon parameters shown, and is for an individual building component, not a truss system. Before use, the building designer must verify the applicability of design parameters and properly incorporate this design into the overall building design. Bracing indicated is to prevent buckling of individual truss web and/or chord members only. Additional temporary and permanent bracing is always required for stability and to prevent collapse with possible personal injury and property damage. For general guidance regarding the fabrication, storage, delivery, erection and bracing of trusses and truss systems, see

ANSI/TPI1 Quality Criteria, DSB-89 and BCSI Building Component

Safety Information available from Truss Plate Institute, 2670 Crain Highway, Suite 203 Waldorf, MD 20601



6904 Parke East Blvd.
 Tampa, FL 36610

Job	Truss	Truss Type	Qty	Ply	IC CONST. - LIBERTY RES.	T25256432
2918935	T10	Monopitch	2	1	Job Reference (optional)	

Builders FirstSource (Lake City,FL), Lake City, FL - 32055,

8.430 s Aug 16 2021 MiTek Industries, Inc. Sat Sep 4 11:23:45 2021 Page 1

ID:b2ldskJGjOxOjHDJPP?LTyh2aU-1w_3T1s4PLq2d9YQWqiRqeVdVdz363vvVgiQY7yh11i

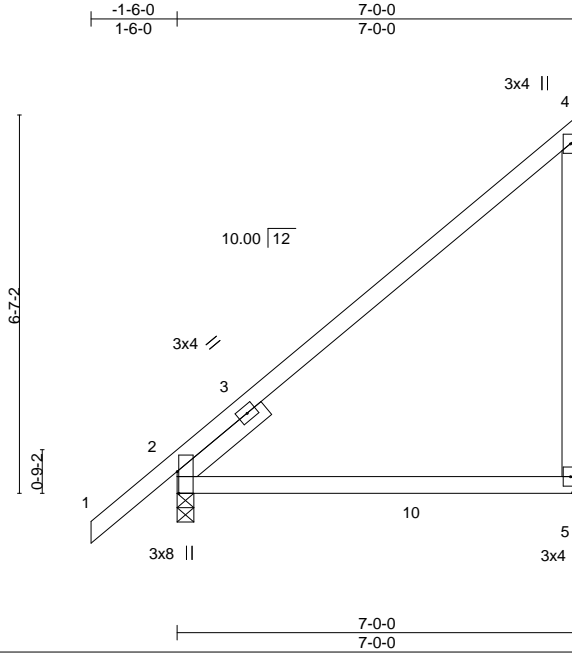

Scale = 1:40.2

Plate Offsets (X,Y)-- [2:0-4-9,Edge]

LOADING (psf)	SPACING-	CSL.	DEFL.	in	(loc)	l/defl	L/d	PLATES	GRIP
TCLL 20.0	Plate Grip DOL 1.25	TC 0.53	Vert(LL) 0.12	5-8	>661	240		MT20	244/190
TCDL 7.0	Lumber DOL 1.25	BC 0.51	Vert(CT) -0.21	5-8	>387	180			
BCLL 0.0 *	Rep Stress Incr YES	WB 0.00	Horz(CT) 0.04	2	n/a	n/a			
BCDL 10.0	Code FBC2020/TPI2014	Matrix-MS							
								Weight: 39 lb	FT = 20%

LUMBER-

TOP CHORD 2x4 SP No.2
 BOT CHORD 2x4 SP No.2
 WEBS 2x4 SP No.3
 SLIDER Left 2x4 SP No.3 1-11-8

BRACING-

TOP CHORD Structural wood sheathing directly applied or 6'-0-0 oc purlins, except end verticals.
 BOT CHORD Rigid ceiling directly applied or 10'-0-0 oc bracing.

REACTIONS.

(size) 5=Mechanical, 2=0-3-8
 Max Horz 2=233(LC 12)
 Max Uplift 5=158(LC 12), 2=11(LC 12)
 Max Grav 5=353(LC 19), 2=368(LC 19)

FORCES. (lb) - Max. Comp./Max. Ten. - All forces 250 (lb) or less except when shown.

TOP CHORD 2-4=538/173

NOTES-

- 1) Wind: ASCE 7-16; Vult=130mph (3-second gust) Vasd=101mph; TCDL=4.2psf; BCDL=3.0psf; h=20ft; Cat. II; Exp B; Encl., GCpi=0.18; MWFRS (envelope) gable end zone and C-C Exterior(2E) -1-6-0 to 1-6-0, Interior(1) 1-6-0 to 6-10-4 zone; end vertical left exposed; C-C for members and forces & MWFRS for reactions shown; Lumber DOL=1.60 plate grip DOL=1.60
- 2) Building Designer / Project engineer responsible for verifying applied roof live load shown covers rain loading requirements specific to the use of this truss component.
- 3) This truss has been designed for a 10.0 psf bottom chord live load nonconcurrent with any other live loads.
- 4) * This truss has been designed for a live load of 20.0psf on the bottom chord in all areas where a rectangle 3'-6-0 tall by 2'-0-0 wide will fit between the bottom chord and any other members, with BCDL = 10.0psf.
- 5) Refer to girder(s) for truss to truss connections.
- 6) Provide mechanical connection (by others) of truss to bearing plate capable of withstanding 100 lb uplift at joint(s) 2 except (jt=lb) 5=158.

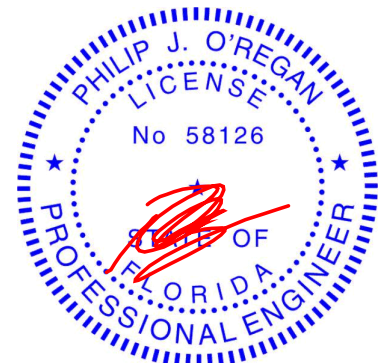

Philip J. O'Regan PE No.58126
 MiTek USA, Inc. FL Cert 6634
 6904 Parke East Blvd. Tampa FL 33610
 Date:

September 7, 2021

WARNING - Verify design parameters and READ NOTES ON THIS AND INCLUDED MITEK REFERENCE PAGE MII-7473 rev. 5/19/2020 BEFORE USE.

Design valid for use only with MiTek® connectors. This design is based only upon parameters shown, and is for an individual building component, not a truss system. Before use, the building designer must verify the applicability of design parameters and properly incorporate this design into the overall building design. Bracing indicated is to prevent buckling of individual truss web and/or chord members only. Additional temporary and permanent bracing is always required for stability and to prevent collapse with possible personal injury and property damage. For general guidance regarding the fabrication, storage, delivery, erection and bracing of trusses and truss systems, see

ANSI/TPI1 Quality Criteria, DSB-89 and BCSI Building Component

Safety Information available from Truss Plate Institute, 2670 Crain Highway, Suite 203 Waldorf, MD 20601



6904 Parke East Blvd.
 Tampa, FL 36610

Job	Truss	Truss Type	Qty	Ply	IC CONST. - LIBERTY RES.	T25256433
2918935	T11	Monopitch	2	1	Job Reference (optional)	

Builders FirstSource (Lake City,FL), Lake City, FL - 32055,

8.430 s Aug 16 2021 MiTek Industries, Inc. Sat Sep 4 11:23:45 2021 Page 1

ID:b2ldskJGjOxOjHDJpP?LTyh2aU-1w_3T1s4PLq2d9YQWqiRqeVdddzS63vVgjiQY7yh11

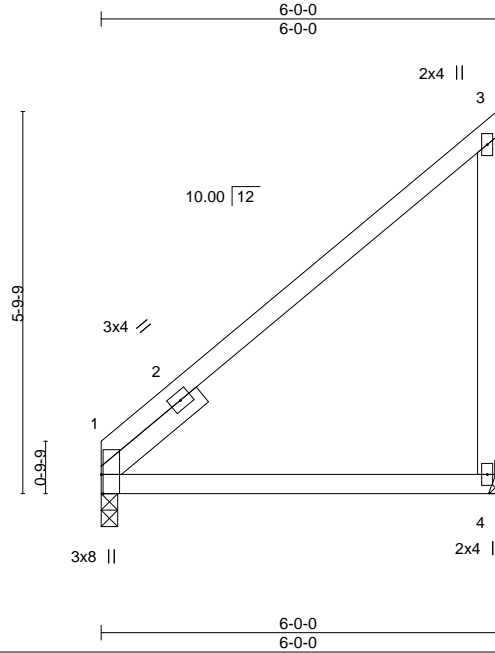

Scale = 1:34.9

Plate Offsets (X,Y)--	[1:0-3-8,Edge]
-----------------------	----------------

LOADING (psf)	SPACING-	CSL.	DEFL.	in (loc)	l/defl	L/d	PLATES	GRIP
TCLL 20.0	2-0-0	TC 0.52	Vert(LL)	0.11	4-7	>645	MT20	244/190
TCDL 7.0	Plate Grip DOL 1.25	BC 0.55	Vert(CT)	-0.13	4-7	>556		
BCLL 0.0 *	Lumber DOL 1.25	WB 0.00	Horz(CT)	-0.04	1	n/a		
BCDL 10.0	Rep Stress Incr YES	Matrix-MP						
	Code FBC2020/TPI2014						Weight: 31 lb	FT = 20%

LUMBER-

TOP CHORD 2x4 SP No.2
 BOT CHORD 2x4 SP No.2
 WEBS 2x4 SP No.3
 SLIDER Left 2x4 SP No.3 1-11-8

BRACING-

TOP CHORD Structural wood sheathing directly applied or 6-0-0 oc purlins, except end verticals.
 BOT CHORD Rigid ceiling directly applied or 10-0-0 oc bracing.

REACTIONS.

(size) 1=0-3-0, 4=Mechanical
 Max Horz 1=168(LC 12)
 Max Uplift 4=142(LC 12)
 Max Grav 1=217(LC 1), 4=237(LC 19)

FORCES. (lb) - Max. Comp./Max. Ten. - All forces 250 (lb) or less except when shown.

TOP CHORD 1-3=303/102

NOTES-

- 1) Wind: ASCE 7-16; Vult=130mph (3-second gust) Vasd=101mph; TCDL=4.2psf; BCDL=3.0psf; h=20ft; Cat. II; Exp B; Encl., GCpi=0.18; MWFRS (envelope) gable end zone and C-C Exterior(2E) 0-0-0 to 3-0-0, Interior(1) 3-0-0 to 5-10-4 zone; C-C for members and forces & MWFRS for reactions shown; Lumber DOL=1.60 plate grip DOL=1.60
- 2) Building Designer / Project engineer responsible for verifying applied roof live load shown covers rain loading requirements specific to the use of this truss component.
- 3) This truss has been designed for a 10.0 psf bottom chord live load nonconcurrent with any other live loads.
- 4) * This truss has been designed for a live load of 20.0psf on the bottom chord in all areas where a rectangle 3-6-0 tall by 2-0-0 wide will fit between the bottom chord and any other members.
- 5) Refer to girder(s) for truss to truss connections.
- 6) Provide mechanical connection (by others) of truss to bearing plate capable of withstanding 100 lb uplift at joint(s) except (jt=lb) 4=142.

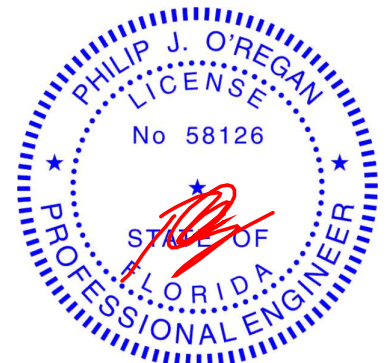

Philip J. O'Regan PE No.58126
 MiTek USA, Inc. FL Cert 6634
 6904 Parke East Blvd. Tampa FL 33610
 Date:

September 7, 2021

WARNING - Verify design parameters and READ NOTES ON THIS AND INCLUDED MITEK REFERENCE PAGE MII-7473 rev. 5/19/2020 BEFORE USE.

Design valid for use only with MiTek® connectors. This design is based only upon parameters shown, and is for an individual building component, not a truss system. Before use, the building designer must verify the applicability of design parameters and properly incorporate this design into the overall building design. Bracing indicated is to prevent buckling of individual truss web and/or chord members only. Additional temporary and permanent bracing is always required for stability and to prevent collapse with possible personal injury and property damage. For general guidance regarding the fabrication, storage, delivery, erection and bracing of trusses and truss systems, see

ANSI/TPI1 Quality Criteria, DSB-89 and BCSI Building Component

Safety Information available from Truss Plate Institute, 2670 Crain Highway, Suite 203 Waldorf, MD 20601



6904 Parke East Blvd.
 Tampa, FL 36610

Job 2918935	Truss T12	Truss Type Roof Special Girder	Qty 1	Ply 1	IC CONST. - LIBERTY RES. Job Reference (optional)	T25256434
----------------	--------------	-----------------------------------	----------	----------	--	-----------

Builders FirstSource (Lake City, FL), Lake City, FL - 32055, 8.430 s Aug 16 2021 MiTek Industries, Inc. Sat Sep 4 11:23:47 2021 Page 1

ID:b2ldskJGjOxOjHDJPP?LTyh2aU-zJ6pujuLxy4msTioeFkvv3a?NRbBapCy_BXd?yh11g



Scale = 1:53.6

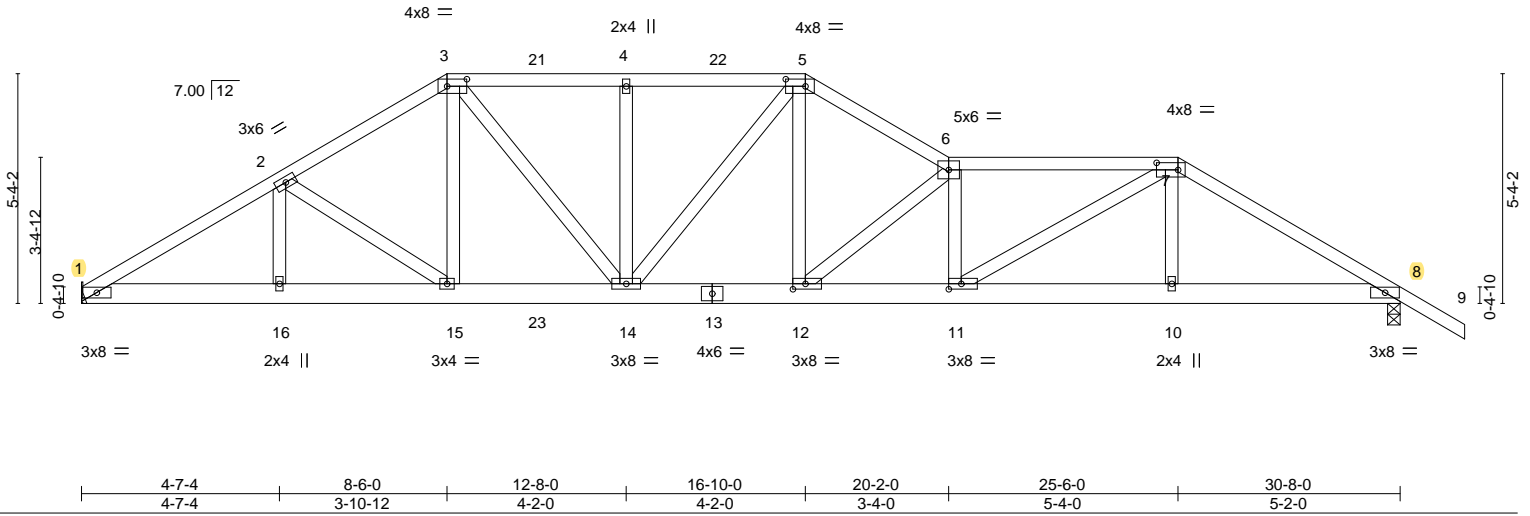

Plate Offsets (X,Y)-- [3:0-5-8,0-2-0], [5:0-5-8,0-2-0], [7:0-6-0,0-2-0], [11:0-3-8,0-1-8], [12:0-3-8,0-1-8]

LOADING (psf)	SPACING-	CSI.	DEFL.	PLATES	GRIP
TCLL 20.0	Plate Grip DOL 1.25	TC 0.44	in (loc) l/defl L/d	MT20	244/190
TCDL 7.0	Lumber DOL 1.25	BC 0.79	Vert(LL) 0.23 11-12 >999 240		
BCLL 0.0 *	Rep Stress Incr NO	WB 0.69	Vert(CT) -0.37 11-12 >999 180		
BCDL 10.0	Code FBC2020/TP12014	Matrix-MS	Horz(CT) 0.09 8 n/a n/a		
				Weight: 195 lb	FT = 20%

LUMBER-	BRACING-
TOP CHORD 2x4 SP No.2 *Except* 6-7: 2x4 SP M 31	TOP CHORD Structural wood sheathing directly applied or 3-0-8 oc purlins.
BOT CHORD 2x6 SP No.2	BOT CHORD Rigid ceiling directly applied or 5-6-0 oc bracing.
WEBS 2x4 SP No.3	

REACTIONS. (size) 1=Mechanical, 8=0-3-8
 Max Horz 1=-122(LC 32)
 Max Uplift 1=-700(LC 8), 8=-831(LC 9)
 Max Grav 1=1717(LC 1), 8=1811(LC 1)

FORCES. (lb) - Max. Comp./Max. Ten. - All forces 250 (lb) or less except when shown.
 TOP CHORD 1-2=-3134/1320, 2-3=-2851/1289, 3-4=-2962/1441, 4-5=-2962/1441, 5-6=-3414/1597,
 6-7=-4128/1915, 7-8=-3131/1499
 BOT CHORD 1-16=-1143/2665, 15-16=-1143/2665, 14-15=-1069/2426, 12-14=-1260/2956,
 11-12=-1803/4168, 10-11=-1207/2671, 8-10=-1198/2648
 WEBS 2-15=-367/184, 3-15=-228/571, 3-14=-507/899, 4-14=-461/412, 5-12=-675/1467,
 6-12=-1662/784, 6-11=-828/392, 7-11=-668/1687, 7-10=-199/480

- NOTES-**
- Unbalanced roof live loads have been considered for this design.
 - Wind: ASCE 7-16; Vult=130mph (3-second gust) Vasd=101mph; TCDL=4.2psf; BCDL=3.0psf; h=20ft; Cat. II; Exp B; Encl., GCpi=0.18; MWFRS (envelope) gable end zone; Lumber DOL=1.60 plate grip DOL=1.60
 - Building Designer / Project engineer responsible for verifying applied roof live load shown covers rain loading requirements specific to the use of this truss component.
 - Provide adequate drainage to prevent water ponding.
 - This truss has been designed for a 10.0 psf bottom chord live load nonconcurrent with any other live loads.
 - * This truss has been designed for a live load of 20.0psf on the bottom chord in all areas where a rectangle 3-6-0 tall by 2-0-0 wide will fit between the bottom chord and any other members.
 - Refer to girder(s) for truss to truss connections.
 - Provide mechanical connection (by others) of truss to bearing plate capable of withstanding 100 lb uplift at joint(s) except (jt=lb) 1=700, 8=831.
 - Hanger(s) or other connection device(s) shall be provided sufficient to support concentrated load(s) 113 lb down and 119 lb up at 10-6-12, 113 lb down and 119 lb up at 12-6-5, 113 lb down and 119 lb up at 12-9-4, and 113 lb down and 119 lb up at 14-9-4, and 208 lb down and 202 lb up at 25-6-0 on top chord, and 272 lb down and 190 lb up at 8-6-0, 56 lb down and 25 lb up at 10-6-12, 56 lb down and 25 lb up at 12-6-5, 56 lb down and 25 lb up at 12-9-4, 56 lb down and 25 lb up at 14-9-4, and 272 lb down and 190 lb up at 16-9-4, and 308 lb down and 214 lb up at 25-4-12 on bottom chord. The design/selection of such connection device(s) is the responsibility of others.
 - In the LOAD CASE(S) section, loads applied to the face of the truss are noted as front (F) or back (B).

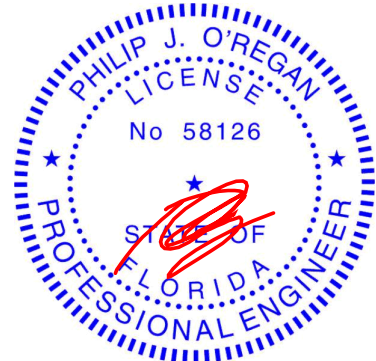

Philip J. O'Regan PE No.58126
 MiTek USA, Inc. FL Cert 6634
 6904 Parke East Blvd. Tampa FL 33610
 Date:

September 7, 2021

Continued on page 2

WARNING - Verify design parameters and READ NOTES ON THIS AND INCLUDED MITEK REFERENCE PAGE MII-7473 rev. 5/19/2020 BEFORE USE.
 Design valid for use only with MiTek® connectors. This design is based only upon parameters shown, and is for an individual building component, not a truss system. Before use, the building designer must verify the applicability of design parameters and properly incorporate this design into the overall building design. Bracing indicated is to prevent buckling of individual truss web and/or chord members only. Additional temporary and permanent bracing is always required for stability and to prevent collapse with possible personal injury and property damage. For general guidance regarding the fabrication, storage, delivery, erection and bracing of trusses and truss systems, see ANSITP1 Quality Criteria, DSB-89 and BCSI Building Component Safety Information available from Truss Plate Institute, 2670 Crain Highway, Suite 203 Waldorf, MD 20601

6904 Parke East Blvd.
 Tampa, FL 33610

Job	Truss	Truss Type	Qty	Ply	IC CONST. - LIBERTY RES.	T25256434
2918935	T12	Roof Special Girder	1	1	Job Reference (optional)	

Builders FirstSource (Lake City,FL), Lake City, FL - 32055,

8.430 s Aug 16 2021 MiTek Industries, Inc. Sat Sep 4 11:23:47 2021 Page 2
ID:b2ldskJGjOxOjHDJPP?LTyh2aU-zJ6pujuLxy4msTioeFkvv3a?NRbBapCy_BXd?yh11g

LOAD CASE(S) Standard

1) Dead + Roof Live (balanced): Lumber Increase=1.25, Plate Increase=1.25

Uniform Loads (plf)

Vert: 1-3=-54, 3-5=-54, 5-6=-54, 6-7=-54, 7-9=-54, 1-8=-20

Concentrated Loads (lb)

Vert: 7=48(F) 13=-37(F) 15=-252(F) 14=-75(F) 4=-132(F) 12=-252(F) 10=-308(F) 21=-66(F) 22=-66(F) 23=-37(F)

WARNING - Verify design parameters and READ NOTES ON THIS AND INCLUDED MITEK REFERENCE PAGE MII-7473 rev. 5/19/2020 BEFORE USE.

Design valid for use only with MiTek® connectors. This design is based only upon parameters shown, and is for an individual building component, not a truss system. Before use, the building designer must verify the applicability of design parameters and properly incorporate this design into the overall building design. Bracing indicated is to prevent buckling of individual truss web and/or chord members only. Additional temporary and permanent bracing is always required for stability and to prevent collapse with possible personal injury and property damage. For general guidance regarding the fabrication, storage, delivery, erection and bracing of trusses and truss systems, see **ANSI/TPI1 Quality Criteria, DSB-89 and BCSI Building Component Safety Information** available from Truss Plate Institute, 2670 Crain Highway, Suite 203 Waldorf, MD 20601



6904 Parke East Blvd.
Tampa, FL 36610

Job	Truss	Truss Type	Qty	Ply	IC CONST. - LIBERTY RES.	T25256435
2918935	T13	Roof Special	1	1		

Job Reference (optional)

Builders FirstSource (Lake City, FL),

Lake City, FL - 32055,

8.430 s Aug 16 2021 MiTek Industries, Inc. Sat Sep 4 11:23:48 2021 Page 1

ID:b2ldskJGjOxOjHJDJPp?LTyh2aU-RVgB63uziGDdUdG?ByF8SH79irzwJHyLBdx59Ryh11f

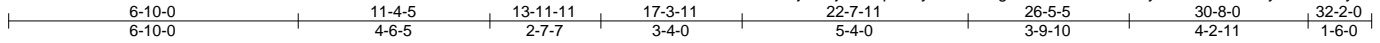

Scale = 1:54.4

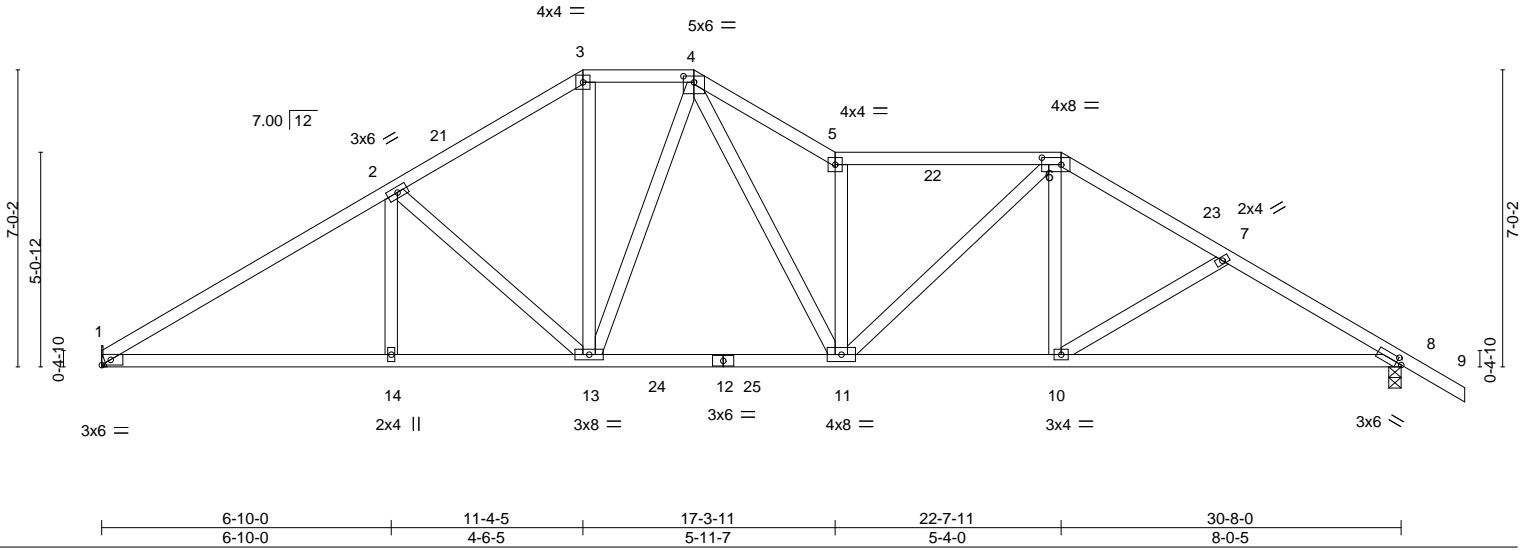

Plate Offsets (X,Y)-- [4:0-3-0,0-1-12], [6:0-5-8,0-2-0], [8:0-1-8,0-1-8]

LOADING (psf)	SPACING-	CSI.	DEFL.	in (loc)	l/defl	L/d	PLATES	GRIP
TCLL 20.0	Plate Grip DOL 1.25	TC 0.47	Vert(LL) -0.16	11-13	>999	240	MT20	244/190
TCDL 7.0	Lumber DOL 1.25	BC 0.70	Vert(CT) -0.28	11-13	>999	180		
BCLL 0.0 *	Rep Stress Incr YES	WB 0.62	Horz(CT) 0.08	8	n/a	n/a		
BCDL 10.0	Code FBC2020/TP12014	Matrix-MS					Weight: 174 lb	FT = 20%

LUMBER-

TOP CHORD 2x4 SP No.2
 BOT CHORD 2x4 SP No.2
 WEBS 2x4 SP No.3

BRACING-

TOP CHORD Structural wood sheathing directly applied or 3-6-8 oc purlins.
 BOT CHORD Rigid ceiling directly applied or 10-0-0 oc bracing.

REACTIONS.

(size) 1=Mechanical, 8=0-3-8
 Max Horz 1=-159(LC 8)
 Max Uplift 1=-205(LC 12), 8=-281(LC 13)
 Max Grav 1=1241(LC 19), 8=1295(LC 2)

FORCES. (lb) - Max. Comp./Max. Ten. - All forces 250 (lb) or less except when shown.

TOP CHORD 1-2=-1991/376, 2-3=-1606/359, 3-4=-1342/338, 4-5=-2359/535, 5-6=-1964/418,
 6-7=-1850/381, 7-8=-2019/431
 BOT CHORD 1-14=-282/1763, 13-14=-282/1763, 11-13=-135/1395, 10-11=-174/1566, 8-10=-292/1728
 WEBS 2-13=-550/209, 3-13=-123/656, 4-13=-262/111, 4-11=-346/1329, 5-11=-1357/375,
 6-11=-109/543, 6-10=-31/375, 7-10=-266/139

NOTES-

- Unbalanced roof live loads have been considered for this design.
- Wind: ASCE 7-16; Vult=130mph (3-second gust) Vasd=101mph; TCCL=4.2psf; BCDL=3.0psf; h=20ft; Cat. II; Exp B; Encl., GCpi=0.18; MWFRS (envelope) gable end zone and C-C Exterior(2E) 0-0-0 to 3-0-13, Interior(1) 3-0-13 to 11-4-5, Exterior(2E) 11-4-5 to 17-3-11, Interior(1) 17-3-11 to 22-7-11, Exterior(2R) 22-7-11 to 25-8-8, Interior(1) 25-8-8 to 32-2-0 zone; C-C for members and forces & MWFRS for reactions shown; Lumber DOL=1.60 plate grip DOL=1.60
- Building Designer / Project engineer responsible for verifying applied roof live load shown covers rain loading requirements specific to the use of this truss component.
- Provide adequate drainage to prevent water ponding.
- This truss has been designed for a 10.0 psf bottom chord live load nonconcurrent with any other live loads.
- * This truss has been designed for a live load of 20.0psf on the bottom chord in all areas where a rectangle 3-6-0 tall by 2-0-0 wide will fit between the bottom chord and any other members, with BCDL = 10.0psf.
- Refer to girder(s) for truss to truss connections.
- Provide mechanical connection (by others) of truss to bearing plate capable of withstanding 100 lb uplift at joint(s) except (jt=lb) 1=205, 8=281.

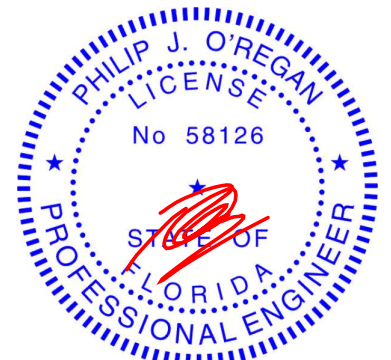

Philip J. O'Regan PE No.58126
 MiTek USA, Inc. FL Cert 6634
 6904 Parke East Blvd. Tampa FL 33610
 Date:

September 7, 2021

WARNING - Verify design parameters and READ NOTES ON THIS AND INCLUDED MITEK REFERENCE PAGE MII-7473 rev. 5/19/2020 BEFORE USE.

Design valid for use only with MiTek® connectors. This design is based only upon parameters shown, and is for an individual building component, not a truss system. Before use, the building designer must verify the applicability of design parameters and properly incorporate this design into the overall building design. Bracing indicated is to prevent buckling of individual truss web and/or chord members only. Additional temporary and permanent bracing is always required for stability and to prevent collapse with possible personal injury and property damage. For general guidance regarding the fabrication, storage, delivery, erection and bracing of trusses and truss systems, see

ANSI/TP1 Quality Criteria, DSB-89 and BCSI Building Component

Safety Information available from Truss Plate Institute, 2670 Crain Highway, Suite 203 Waldorf, MD 20601



6904 Parke East Blvd.
 Tampa, FL 33610

Job	Truss	Truss Type	Qty	Ply	IC CONST. - LIBERTY RES.	T25256436
2918935	T14	Roof Special	1	1		

Builders FirstSource (Lake City,FL), Lake City, FL - 32055,

8.430 s Aug 16 2021 MiTek Industries, Inc. Sat Sep 4 11:23:49 2021 Page 1

ID:b2ldskJGjOxOjHDJPP?LTyh2aU-viEaJPvbTZLT6nrBlgnN?UgLPeIQ2jdUQHgehuyh11e

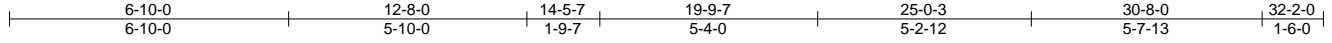

Scale = 1:56.4

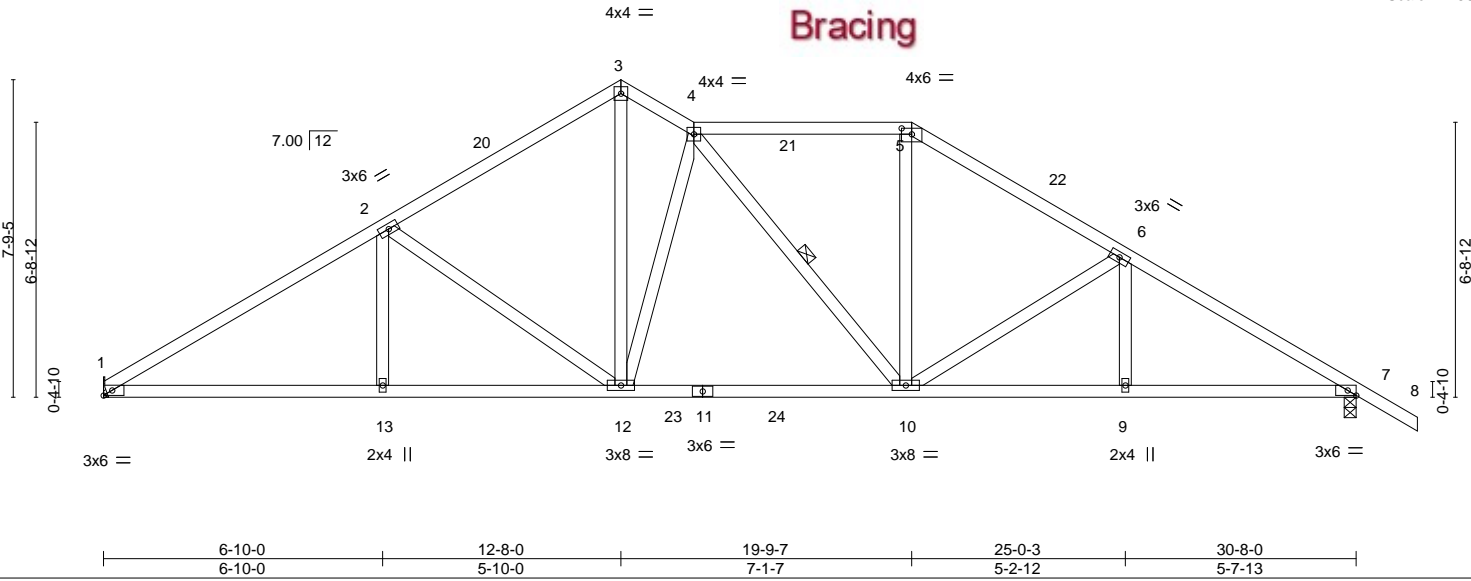

Plate Offsets (X,Y)-- [5:0-3-0,0-1-12], [7:0-2-8,Edge]

LOADING (psf)	SPACING-	CSI.	DEFL.	in (loc)	l/defl	L/d	PLATES	GRIP
TCLL 20.0	Plate Grip DOL 1.25	TC 0.44	Vert(LL) -0.16	10-12	>999	240	MT20	244/190
TCDL 7.0	Lumber DOL 1.25	BC 0.68	Vert(CT) -0.28	10-12	>999	180		
BCLL 0.0 *	Rep Stress Incr YES	WB 0.66	Horz(CT) 0.08	7	n/a	n/a		
BCDL 10.0	Code FBC2020/TP12014	Matrix-MS						
							Weight: 171 lb	FT = 20%

LUMBER-
 TOP CHORD 2x4 SP No.2
 BOT CHORD 2x4 SP No.2
 WEBS 2x4 SP No.3

BRACING-
 TOP CHORD Structural wood sheathing directly applied or 3-7-13 oc purlins.
 BOT CHORD Rigid ceiling directly applied or 10-0-0 oc bracing.
 WEBS 1 Row at midpt 4-10

REACTIONS. (size) 1=Mechanical, 7=0-3-8
 Max Horz 1=-176(LC 8)
 Max Uplift 1=-215(LC 12), 7=-287(LC 13)
 Max Grav 1=1270(LC 19), 7=1308(LC 20)

FORCES. (lb) - Max. Comp./Max. Ten. - All forces 250 (lb) or less except when shown.
 TOP CHORD 1-2=-2047/363, 2-3=-1537/332, 3-4=-1466/355, 4-5=-1385/356, 5-6=-1653/367,
 6-7=-2052/420
 BOT CHORD 1-13=-313/1831, 12-13=-313/1831, 10-12=-152/1518, 9-10=-270/1727, 7-9=-270/1727
 WEBS 2-13=0/258, 2-12=-609/232, 3-12=-277/1294, 4-12=-776/279, 5-10=-64/589,
 6-10=-503/189

- NOTES-**
- Unbalanced roof live loads have been considered for this design.
 - Wind: ASCE 7-16; Vult=130mph (3-second gust) Vasd=101mph; TCCL=4.2psf; BCDL=3.0psf; h=20ft; Cat. II; Exp B; Encl., GCpi=0.18; MWFRS (envelope) gable end zone and C-C Exterior(2E) 0-0-0 to 3-0-13, Interior(1) 3-0-13 to 12-8-0, Exterior(2E) 12-8-0 to 14-5-7, Interior(1) 14-5-7 to 19-9-7, Exterior(2R) 19-9-7 to 22-10-4, Interior(1) 22-10-4 to 32-2-0 zone; C-C for members and forces & MWFRS for reactions shown; Lumber DOL=1.60 plate grip DOL=1.60
 - Building Designer / Project engineer responsible for verifying applied roof live load shown covers rain loading requirements specific to the use of this truss component.
 - Provide adequate drainage to prevent water ponding.
 - This truss has been designed for a 10.0 psf bottom chord live load nonconcurrent with any other live loads.
 - * This truss has been designed for a live load of 20.0psf on the bottom chord in all areas where a rectangle 3-6-0 tall by 2-0-0 wide will fit between the bottom chord and any other members, with BCDL = 10.0psf.
 - Refer to girder(s) for truss to truss connections.
 - Provide mechanical connection (by others) of truss to bearing plate capable of withstanding 100 lb uplift at joint(s) except (jt=lb) 1=215, 7=287.

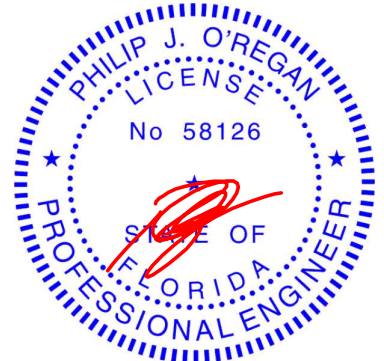

Philip J. O'Regan PE No.58126
 MiTek USA, Inc. FL Cert 6634
 6904 Parke East Blvd. Tampa FL 33610
 Date:

September 7, 2021

WARNING - Verify design parameters and READ NOTES ON THIS AND INCLUDED MITEK REFERENCE PAGE MII-7473 rev. 5/19/2020 BEFORE USE.

Design valid for use only with MiTek® connectors. This design is based only upon parameters shown, and is for an individual building component, not a truss system. Before use, the building designer must verify the applicability of design parameters and properly incorporate this design into the overall building design. Bracing indicated is to prevent buckling of individual truss web and/or chord members only. Additional temporary and permanent bracing is always required for stability and to prevent collapse with possible personal injury and property damage. For general guidance regarding the fabrication, storage, delivery, erection and bracing of trusses and truss systems, see

ANSI/TP1 Quality Criteria, DSB-89 and BCSI Building Component

Safety Information available from Truss Plate Institute, 2670 Crain Highway, Suite 203 Waldorf, MD 20601



6904 Parke East Blvd.
 Tampa, FL 33610

Job 2918935	Truss T15	Truss Type Hip	Qty 1	Ply 1	IC CONST. - LIBERTY RES. Job Reference (optional)	T25256437
----------------	--------------	-------------------	----------	----------	--	-----------

Builders FirstSource (Lake City, FL), Lake City, FL - 32055,

8.430 s Aug 16 2021 MiTek Industries, Inc. Sat Sep 4 11:23:51 2021 Page 1

ID:b2ldsklJGjOxOjHDJpp?LTyh2aU-r4MKk5xr_BbBL4?Zt5pr4vlgG2?BWcintb9lmmyh11c

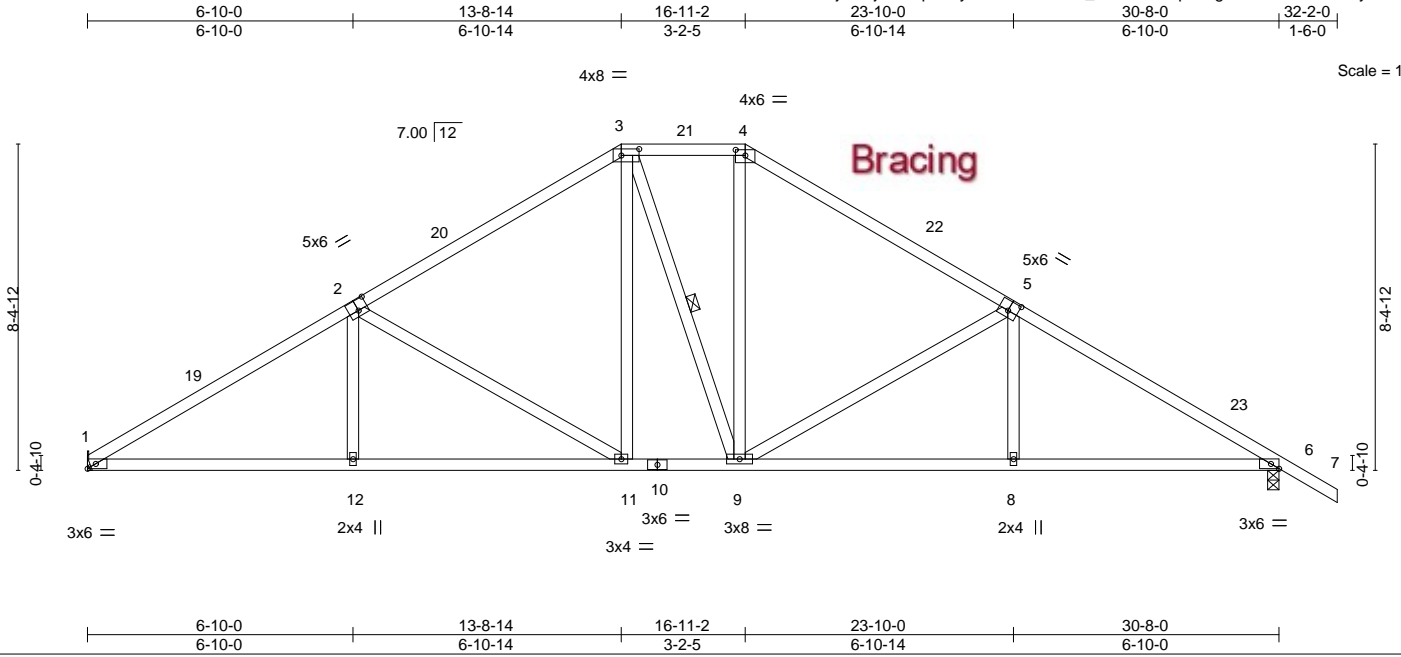

Plate Offsets (X,Y)--	[2:0-3-0,0-3-4], [3:0-5-8,0-2-0], [4:0-3-0,0-1-12], [5:0-3-0,0-3-0], [6:0-2-8,Edge]
-----------------------	---

LOADING (psf)	SPACING-	CSI.	DEFL.	PLATES	GRIP
TCLL 20.0	Plate Grip DOL 1.25	TC 0.51	in (loc) l/defl L/d	MT20	244/190
TCDL 7.0	Lumber DOL 1.25	BC 0.60	Vert(LL) -0.09 11-12 >999 240		
BCLL 0.0 *	Rep Stress Incr YES	WB 0.75	Vert(CT) -0.20 11-12 >999 180		
BCDL 10.0	Code FBC2020/TPI2014	Matrix-MS	Horz(CT) 0.07 6 n/a n/a		
				Weight: 171 lb	FT = 20%

LUMBER-	BRACING-
TOP CHORD 2x4 SP No.2	TOP CHORD Structural wood sheathing directly applied or 3-9-15 oc purlins.
BOT CHORD 2x4 SP No.2	BOT CHORD Rigid ceiling directly applied or 9-7-10 oc bracing.
WEBS 2x4 SP No.3	WEBS 1 Row at midpt 3-9

REACTIONS. (size) 1=Mechanical, 6=0-3-8
 Max Horz 1=190(LC 8)
 Max Uplift 1=234(LC 12), 6=267(LC 13)
 Max Grav 1=1133(LC 1), 6=1218(LC 1)

FORCES. (lb) - Max. Comp./Max. Ten. - All forces 250 (lb) or less except when shown.
 TOP CHORD 1-2=1886/379, 2-3=1343/297, 3-4=1075/304, 4-5=1344/295, 5-6=1874/371
 BOT CHORD 1-12=357/1565, 11-12=357/1563, 9-11=136/1074, 8-9=217/1550, 6-8=217/1553
 WEBS 2-12=0/302, 2-11=599/258, 3-11=97/395, 4-9=95/396, 5-9=585/251, 5-8=0/298

- NOTES-**
- Unbalanced roof live loads have been considered for this design.
 - Wind: ASCE 7-16; Vult=130mph (3-second gust) Vasd=101mph; TCCL=4.2psf; BCDL=3.0psf; h=20ft; Cat. II; Exp B; Encl., GCpi=0.18; MWFRS (envelope) gable end zone and C-C Exterior(2E) 0-0-0 to 3-0-13, Interior(1) 3-0-13 to 13-8-14, Exterior(2E) 13-8-14 to 16-11-2, Exterior(2R) 16-11-2 to 21-3-3, Interior(1) 21-3-3 to 32-2-0 zone; C-C for members and forces & MWFRS for reactions shown; Lumber DOL=1.60 plate grip DOL=1.60
 - Building Designer / Project engineer responsible for verifying applied roof live load shown covers rain loading requirements specific to the use of this truss component.
 - Provide adequate drainage to prevent water ponding.
 - This truss has been designed for a 10.0 psf bottom chord live load nonconcurrent with any other live loads.
 - * This truss has been designed for a live load of 20.0psf on the bottom chord in all areas where a rectangle 3-6-0 tall by 2-0-0 wide will fit between the bottom chord and any other members.
 - Refer to girder(s) for truss to truss connections.
 - Provide mechanical connection (by others) of truss to bearing plate capable of withstanding 100 lb uplift at joint(s) except (jt=lb) 1=234, 6=267.

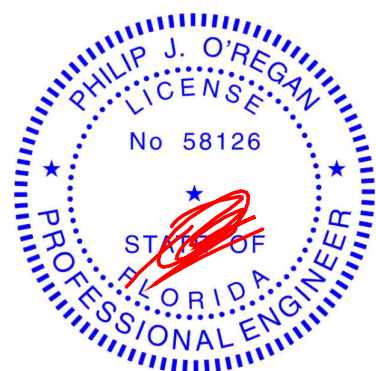

Philip J. O'Regan PE No.58126
 MiTek USA, Inc. FL Cert 6634
 6904 Parke East Blvd. Tampa FL 33610
 Date: September 7, 2021

Job 2918935	Truss T16	Truss Type Roof Special	Qty 1	Ply 1	IC CONST. - LIBERTY RES. Job Reference (optional)	T25256438
----------------	--------------	----------------------------	----------	----------	--	-----------

Builders FirstSource (Lake City,FL), Lake City, FL - 32055,

8.430 s Aug 16 2021 MiTek Industries, Inc. Sat Sep 4 11:23:52 2021 Page 1
ID:tb2ldskJGjOxOjHDJpP?LTyh2aU-KHvixRxUIUj2zEamQoK4c7l0oSK_F12x6FvIDyh11b



4x6 =

Scale = 1:60.2

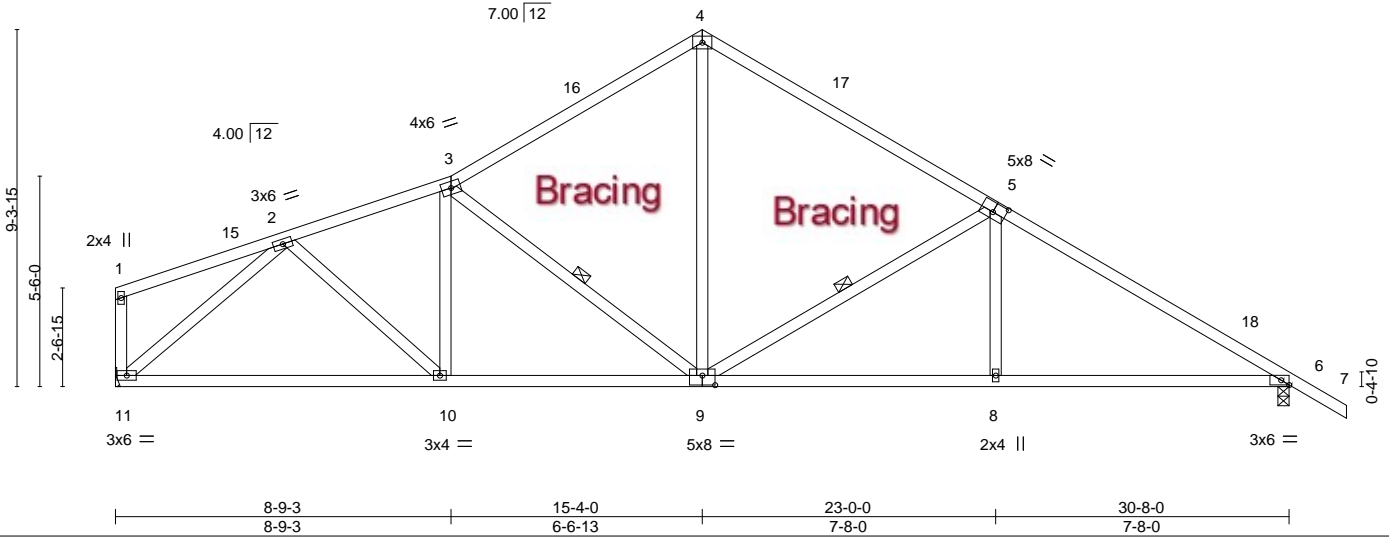

Plate Offsets (X,Y)-- [5:0-4-0-0-3-0], [6:0-2-8,Edge], [9:0-4-0-0-3-0]

LOADING (psf)	SPACING-	CSI.	DEFL.	PLATES	GRIP
TCLL 20.0	Plate Grip DOL 1.25	TC 0.65	in (loc) l/defl L/d	MT20	244/190
TCDL 7.0	Lumber DOL 1.25	BC 0.69	Vert(LL) -0.15 10-11 >999 240		
BCLL 0.0 *	Rep Stress Incr YES	WB 0.87	Vert(CT) -0.31 10-11 >999 180		
BCDL 10.0	Code FBC2020/TPI2014	Matrix-MS	Horz(CT) 0.06 6 n/a n/a		
				Weight: 171 lb	FT = 20%

LUMBER-

TOP CHORD 2x4 SP No.2
BOT CHORD 2x4 SP No.2
WEBS 2x4 SP No.3

BRACING-

TOP CHORD Structural wood sheathing directly applied or 3-9-8 oc purlins, except end verticals.
BOT CHORD Rigid ceiling directly applied or 10-0-0 oc bracing.
WEBS 1 Row at midpt 3-9, 5-9

REACTIONS.

(size) 11=Mechanical, 6=0-3-8
Max Horz 11=-203(LC 13)
Max Uplift 11=-231(LC 12), 6=-260(LC 13)
Max Grav 11=1127(LC 1), 6=1212(LC 1)

FORCES. (lb) - Max. Comp./Max. Ten. - All forces 250 (lb) or less except when shown.

TOP CHORD 2-3=-1485/433, 3-4=-1214/412, 4-5=-1245/408, 5-6=-1833/474
BOT CHORD 10-11=-267/1098, 9-10=-262/1377, 8-9=-303/1510, 6-8=-303/1510
WEBS 2-10=-43/383, 3-9=-526/212, 4-9=-207/766, 5-9=-652/281, 5-8=0/330, 2-11=-1402/401

NOTES-

- Unbalanced roof live loads have been considered for this design.
- Wind: ASCE 7-16; Vult=130mph (3-second gust) Vasd=101mph; TCDL=4.2psf; BCDL=3.0psf; h=20ft; Cat. II; Exp B; Encl., GCpi=0.18; MWFRS (envelope) gable end zone and C-C Exterior(2E) 0-1-12 to 3-2-9, Interior(1) 3-2-9 to 15-4-0, Exterior(2R) 15-4-0 to 18-4-13, Interior(1) 18-4-13 to 32-2-0 zone;C-C for members and forces & MWFRS for reactions shown; Lumber DOL=1.60 plate grip DOL=1.60
- Building Designer / Project engineer responsible for verifying applied roof live load shown covers rain loading requirements specific to the use of this truss component.
- This truss has been designed for a 10.0 psf bottom chord live load nonconcurrent with any other live loads.
- * This truss has been designed for a live load of 20.0psf on the bottom chord in all areas where a rectangle 3-6-0 tall by 2-0-0 wide will fit between the bottom chord and any other members.
- Refer to girder(s) for truss to truss connections.
- Provide mechanical connection (by others) of truss to bearing plate capable of withstanding 100 lb uplift at joint(s) except (jt=lb) 11=231, 6=260.

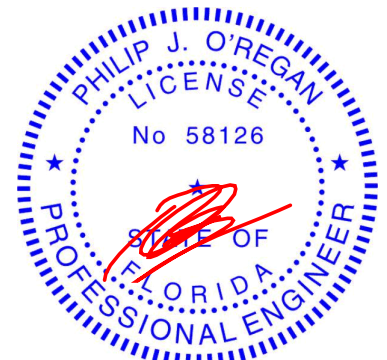

Philip J. O'Regan PE No.58126
MiTek USA, Inc. FL Cert 6634
6904 Parke East Blvd. Tampa FL 33610
Date:

September 7, 2021

WARNING - Verify design parameters and READ NOTES ON THIS AND INCLUDED MITEK REFERENCE PAGE MII-7473 rev. 5/19/2020 BEFORE USE.

Design valid for use only with MiTek® connectors. This design is based only upon parameters shown, and is for an individual building component, not a truss system. Before use, the building designer must verify the applicability of design parameters and properly incorporate this design into the overall building design. Bracing indicated is to prevent buckling of individual truss web and/or chord members only. Additional temporary and permanent bracing is always required for stability and to prevent collapse with possible personal injury and property damage. For general guidance regarding the fabrication, storage, delivery, erection and bracing of trusses and truss systems, see

ANSI/TPI1 Quality Criteria, DSB-89 and BCSI Building Component

Safety Information available from Truss Plate Institute, 2670 Crain Highway, Suite 203 Waldorf, MD 20601



6904 Parke East Blvd.
Tampa, FL 36610

Job	Truss	Truss Type	Qty	Ply	IC CONST. - LIBERTY RES.	T25256439
2918935	T17	Roof Special	1	1		

Builders FirstSource (Lake City,FL), Lake City, FL - 32055,

8.430 s Aug 16 2021 MiTek Industries, Inc. Sat Sep 4 11:23:53 2021 Page 1
ID:b2ldskJGjOxOjHDJPP?LTyh2aU-oTT49my6WorvaO9y_WrJ9KqzNsgD_UG4Lverrfyh11a



4x6 =

Scale = 1:59.3

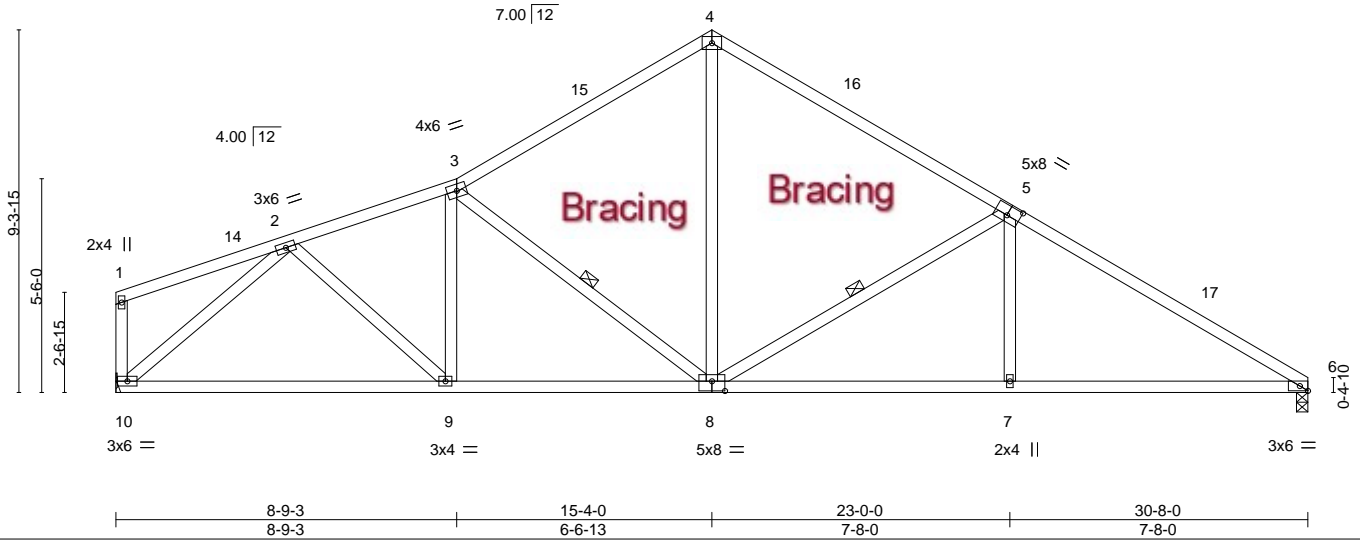

Plate Offsets (X,Y)-- [5:0-4-0,0-3-0], [6:0-2-8,Edge], [8:0-4-0,0-3-0]

LOADING (psf)	SPACING-	CSI.	DEFL.	in (loc)	l/defl	L/d	PLATES	GRIP
TCLL 20.0	Plate Grip DOL 1.25	TC 0.66	Vert(LL) -0.15	9-10	>999	240	MT20	244/190
TCDL 7.0	Lumber DOL 1.25	BC 0.69	Vert(CT) -0.31	9-10	>999	180		
BCLL 0.0 *	Rep Stress Incr YES	WB 0.87	Horz(CT) 0.06	6	n/a	n/a		
BCDL 10.0	Code FBC2020/TPI2014	Matrix-MS					Weight: 168 lb	FT = 20%

LUMBER-

TOP CHORD 2x4 SP No.2
BOT CHORD 2x4 SP No.2
WEBS 2x4 SP No.3

BRACING-

TOP CHORD Structural wood sheathing directly applied or 3-7-5 oc purlins, except end verticals.
BOT CHORD Rigid ceiling directly applied or 9-9-11 oc bracing.
WEBS 1 Row at midpt 3-8, 5-8

REACTIONS.

(size) 10=Mechanical, 6=0-3-8
Max Horz 10=187(LC 11)
Max Uplift 10=-231(LC 12), 6=-228(LC 13)
Max Grav 10=1129(LC 1), 6=1129(LC 1)

FORCES. (lb) - Max. Comp./Max. Ten. - All forces 250 (lb) or less except when shown.

TOP CHORD 2-3=-1489/435, 3-4=-1218/414, 4-5=-1249/413, 5-6=-1847/491
BOT CHORD 9-10=-280/1101, 8-9=-275/1380, 7-8=-338/1524, 6-7=-338/1524
WEBS 2-9=-45/383, 3-8=-526/212, 4-8=-210/771, 5-8=-664/288, 5-7=0/331, 2-10=-1405/402

NOTES-

- Unbalanced roof live loads have been considered for this design.
- Wind: ASCE 7-16; Vult=130mph (3-second gust) Vasd=101mph; TCDL=4.2psf; BCDL=3.0psf; h=20ft; Cat. II; Exp B; Encl., GCpi=0.18; MWFRS (envelope) gable end zone and C-C Exterior(2E) 0-1-12 to 3-2-9, Interior(1) 3-2-9 to 15-4-0, Exterior(2R) 15-4-0 to 18-4-13, Interior(1) 18-4-13 to 30-8-0 zone;C-C for members and forces & MWFRS for reactions shown; Lumber DOL=1.60 plate grip DOL=1.60
- Building Designer / Project engineer responsible for verifying applied roof live load shown covers rain loading requirements specific to the use of this truss component.
- This truss has been designed for a 10.0 psf bottom chord live load nonconcurrent with any other live loads.
- * This truss has been designed for a live load of 20.0psf on the bottom chord in all areas where a rectangle 3-6-0 tall by 2-0-0 wide will fit between the bottom chord and any other members.
- Refer to girder(s) for truss to truss connections.
- Provide mechanical connection (by others) of truss to bearing plate capable of withstanding 100 lb uplift at joint(s) except (jt=lb) 10=231, 6=228.

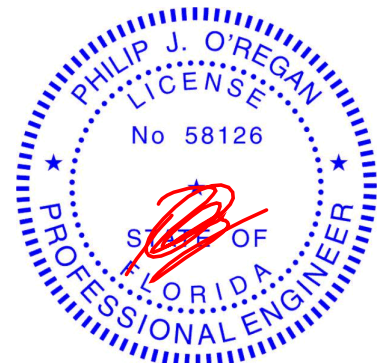

Philip J. O'Regan PE No.58126
MiTek USA, Inc. FL Cert 6634
6904 Parke East Blvd. Tampa FL 33610
Date:

September 7,2021

WARNING - Verify design parameters and READ NOTES ON THIS AND INCLUDED MITEK REFERENCE PAGE MII-7473 rev. 5/19/2020 BEFORE USE.

Design valid for use only with MiTek® connectors. This design is based only upon parameters shown, and is for an individual building component, not a truss system. Before use, the building designer must verify the applicability of design parameters and properly incorporate this design into the overall building design. Bracing indicated is to prevent buckling of individual truss web and/or chord members only. Additional temporary and permanent bracing is always required for stability and to prevent collapse with possible personal injury and property damage. For general guidance regarding the fabrication, storage, delivery, erection and bracing of trusses and truss systems, see

ANSI/TPI1 Quality Criteria, DSB-89 and BCSI Building Component

Safety Information available from Truss Plate Institute, 2670 Crain Highway, Suite 203 Waldorf, MD 20601



6904 Parke East Blvd.
Tampa, FL 33610

Job	Truss	Truss Type	Qty	Ply	IC CONST. - LIBERTY RES.	T25256440
2918935	T18	Roof Special Girder	1	1		

Builders FirstSource (Lake City, FL), Lake City, FL - 32055, 8.430 s Aug 16 2021 MiTek Industries, Inc. Sat Sep 4 11:23:55 2021 Page 1
 ID:b2ldskJGjOxOjHDJPP?LTyh2aU-ksbraS_M2P5dqjL6wtnEivEYIN7SPTNoD7yvXyh11Y
 -1-6-0, 7-3-8, 12-5-3, 17-7-12, 19-0-0, 22-4-11, 25-9-7, 28-0-0, 32-7-12, 37-3-8
 1-6-0, 7-3-8, 5-1-11, 5-2-9, 1-4-4, 3-4-11, 3-4-11, 2-2-9, 4-7-12, 4-7-12

Scale = 1:69.8

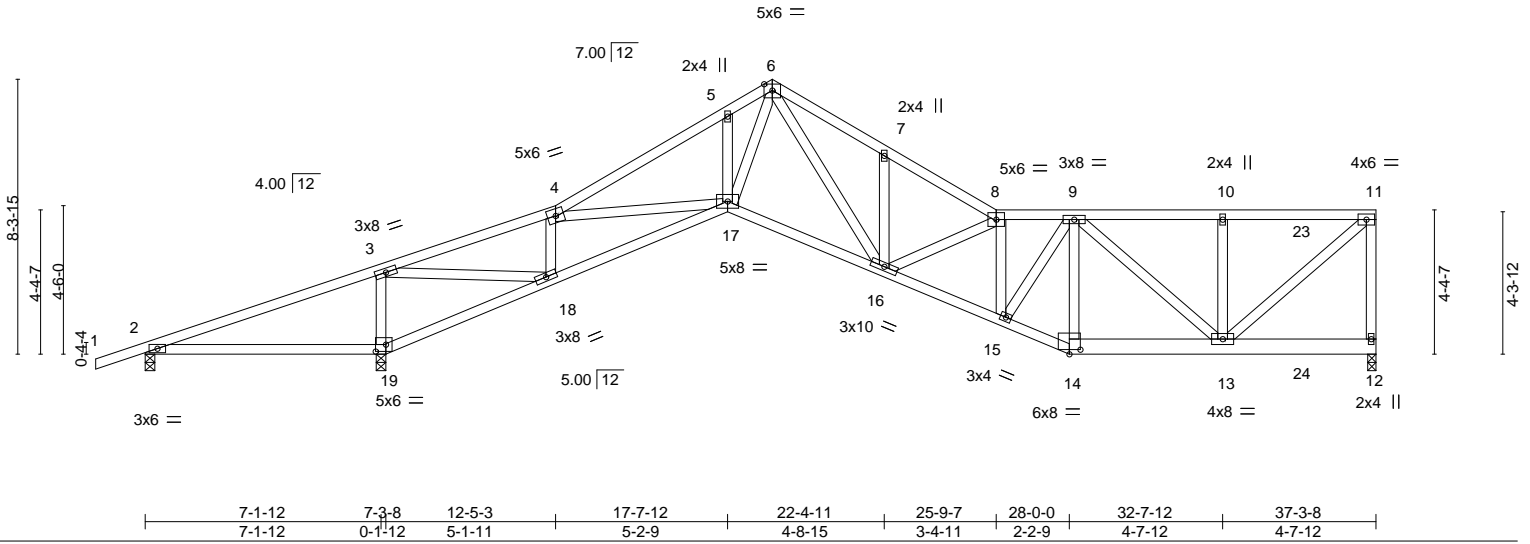

Plate Offsets (X,Y)-- [14:0-4-0,0-1-11], [19:0-3-12,0-2-8]

LOADING (psf)	SPACING-	CSI.	DEFL.	PLATES	GRIP
TCLL 20.0	Plate Grip DOL 1.25	TC 1.00	in (loc) l/defl L/d	MT20	244/190
TCDL 7.0	Lumber DOL 1.25	BC 0.60	Vert(LL) -0.16 16 >999 240		
BCLL 0.0 *	Rep Stress Incr NO	WB 0.83	Vert(CT) -0.30 16-17 >999 180		
BCDL 10.0	Code FBC2020/TP12014	Matrix-MS	Horz(CT) 0.15 12 n/a n/a		
				Weight: 221 lb	FT = 20%

LUMBER-	BRACING-
TOP CHORD 2x4 SP No.2	TOP CHORD Structural wood sheathing directly applied or 3-7-6 oc purlins, except end verticals.
BOT CHORD 2x4 SP No.2 *Except* 12-14: 2x6 SP No.2	BOT CHORD Rigid ceiling directly applied or 3-10-11 oc bracing.
WEBS 2x4 SP No.3	

REACTIONS. (size) 12=0-3-0, 2=0-3-8, 19=0-3-8
 Max Horz 2=247(LC 5)
 Max Uplift 12=-409(LC 9), 2=-342(LC 33), 19=-438(LC 8)
 Max Grav 12=953(LC 1), 2=98(LC 9), 19=2089(LC 1)

FORCES. (lb) - Max. Comp./Max. Ten. - All forces 250 (lb) or less except when shown.
 TOP CHORD 2-3=-375/1697, 3-4=-637/129, 4-5=-1983/407, 5-6=-1957/449, 6-7=-1999/533,
 7-8=-1975/445, 8-9=-1909/432, 9-10=-919/239, 10-11=-919/239, 11-12=-910/347
 BOT CHORD 2-19=-1543/304, 18-19=-1778/352, 17-18=-162/688, 16-17=-260/1365, 15-16=-534/2133,
 14-15=-398/1509, 13-14=-373/1412
 WEBS 3-19=-1253/347, 3-18=-380/2171, 4-18=-988/231, 4-17=-229/1041, 5-17=-261/188,
 6-17=-282/1201, 6-16=-317/888, 8-16=-326/104, 8-15=-951/233, 9-15=-198/909,
 9-14=-516/172, 9-13=-658/175, 10-13=-267/159, 11-13=-339/1211

- NOTES-**
- Unbalanced roof live loads have been considered for this design.
 - Wind: ASCE 7-16; Vult=130mph (3-second gust) Vasd=101mph; TCDL=4.2psf; BCDL=3.0psf; h=20ft; Cat. II; Exp B; Encl., GCpi=0.18; MWFRS (envelope) gable end zone; end vertical right exposed; porch left exposed; Lumber DOL=1.60 plate grip DOL=1.60
 - Building Designer / Project engineer responsible for verifying applied roof live load shown covers rain loading requirements specific to the use of this truss component.
 - Provide adequate drainage to prevent water ponding.
 - This truss has been designed for a 10.0 psf bottom chord live load nonconcurrent with any other live loads.
 - * This truss has been designed for a live load of 20.0psf on the bottom chord in all areas where a rectangle 3-6-0 tall by 2-0-0 wide will fit between the bottom chord and any other members.
 - Provide mechanical connection (by others) of truss to bearing plate capable of withstanding 100 lb uplift at joint(s) except (it=lb) 12=409, 2=342, 19=438.
 - Hanger(s) or other connection device(s) shall be provided sufficient to support concentrated load(s) 77 lb down and 66 lb up at 34-11-4, and 66 lb down and 70 lb up at 37-1-12 on top chord, and 47 lb down and 44 lb up at 34-11-4, and 49 lb down and 44 lb up at 37-1-12 on bottom chord. The design/selection of such connection device(s) is the responsibility of others.
 - In the LOAD CASE(S) section, loads applied to the face of the truss are noted as front (F) or back (B).

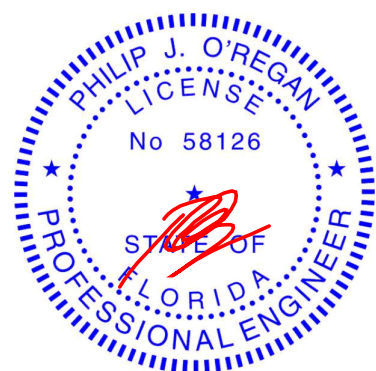

Philip J. O'Regan PE No.58126
 MiTek USA, Inc. FL Cert 6634
 6904 Parke East Blvd. Tampa FL 33610
 Date: September 7, 2021

Continued on page 2

WARNING - Verify design parameters and READ NOTES ON THIS AND INCLUDED MITEK REFERENCE PAGE MII-7473 rev. 5/19/2020 BEFORE USE.
 Design valid for use only with MiTek® connectors. This design is based only upon parameters shown, and is for an individual building component, not a truss system. Before use, the building designer must verify the applicability of design parameters and properly incorporate this design into the overall building design. Bracing indicated is to prevent buckling of individual truss web and/or chord members only. Additional temporary and permanent bracing is always required for stability and to prevent collapse with possible personal injury and property damage. For general guidance regarding the fabrication, storage, delivery, erection and bracing of trusses and truss systems, see ANSI/TP1 Quality Criteria, DSB-89 and BCSI Building Component Safety Information available from Truss Plate Institute, 2670 Crain Highway, Suite 203 Waldorf, MD 20601

6904 Parke East Blvd.
 Tampa, FL 36610

Job	Truss	Truss Type	Qty	Ply	IC CONST. - LIBERTY RES.	T25256440
2918935	T18	Roof Special Girder	1	1	Job Reference (optional)	

Builders FirstSource (Lake City,FL), Lake City, FL - 32055,

8.430 s Aug 16 2021 MiTek Industries, Inc. Sat Sep 4 11:23:55 2021 Page 2
ID:b2ldskJGjOxOjHDJPP?LTyh2aU-ksbraS_M2P5dqjL6wtnEivEYfN7SPTNoD7yvXyh11Y

LOAD CASE(S) Standard

- 1) Dead + Roof Live (balanced): Lumber Increase=1.25, Plate Increase=1.25
Uniform Loads (plf)
Vert: 1-4=-54, 4-6=-54, 6-8=-54, 8-11=-54, 19-20=-20, 17-19=-20, 14-17=-20, 12-14=-20
Concentrated Loads (lb)
Vert: 12=3(F) 24=7(F)

WARNING - Verify design parameters and READ NOTES ON THIS AND INCLUDED MITEK REFERENCE PAGE MII-7473 rev. 5/19/2020 BEFORE USE.

Design valid for use only with MiTek® connectors. This design is based only upon parameters shown, and is for an individual building component, not a truss system. Before use, the building designer must verify the applicability of design parameters and properly incorporate this design into the overall building design. Bracing indicated is to prevent buckling of individual truss web and/or chord members only. Additional temporary and permanent bracing is always required for stability and to prevent collapse with possible personal injury and property damage. For general guidance regarding the fabrication, storage, delivery, erection and bracing of trusses and truss systems, see **ANSI/TPI1 Quality Criteria, DSB-89 and BCSI Building Component Safety Information** available from Truss Plate Institute, 2670 Crain Highway, Suite 203 Waldorf, MD 20601



6904 Parke East Blvd.
Tampa, FL 36610

Job	Truss	Truss Type	Qty	Ply	IC CONST. - LIBERTY RES.	T25256441
2918935	T19	Roof Special	1	1		

Job Reference (optional)

Builders FirstSource (Lake City, FL), Lake City, FL - 32055, 8.430 s Aug 16 2021 MiTek Industries, Inc. Sat Sep 4 11:23:56 2021 Page 1

ID:b2ldsklJGjOxOjHDJPP?LTyh2aU-C29Dno?_pjDURuXfeP0nzSRN3jaBsJW1ttWR_yh11X

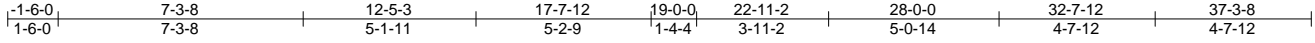

Scale = 1:68.6

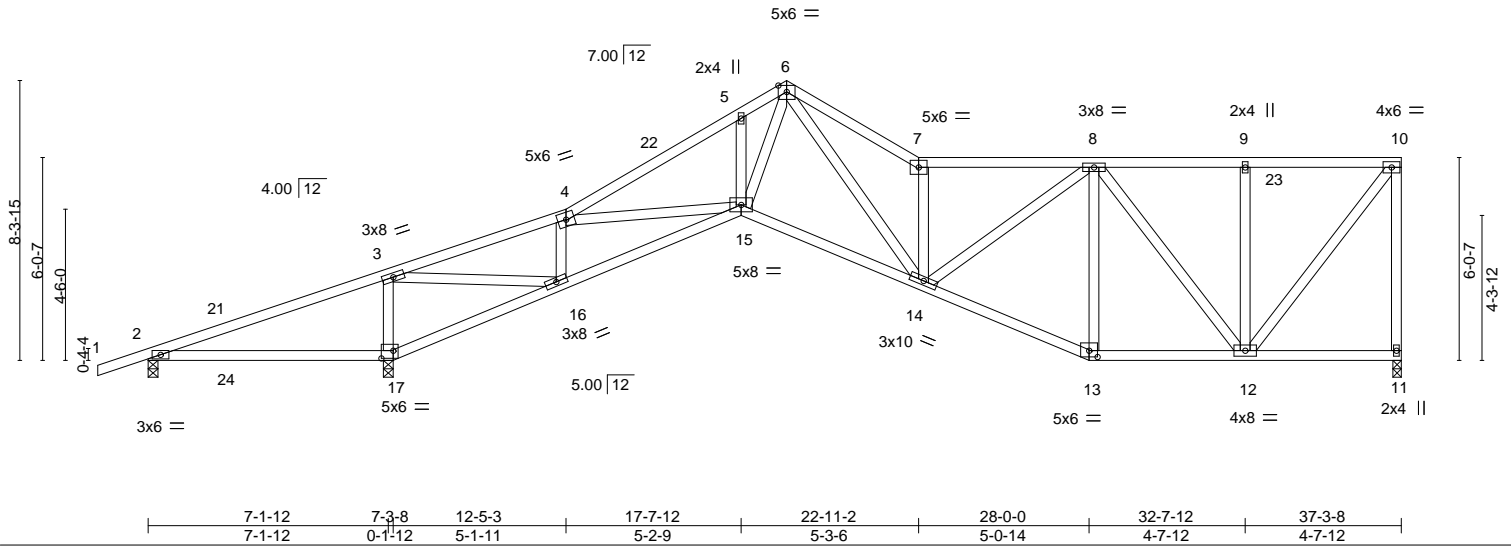

Plate Offsets (X,Y)--	[13:0-3-0,0-2-4], [17:0-4-4,0-2-12]
-----------------------	-------------------------------------

LOADING (psf)	SPACING-	CSI.	DEFL.	PLATES	GRIP
TCLL 20.0	Plate Grip DOL 1.25	TC 0.87	Vert(LL) 0.20 17-20 >429 240	MT20	244/190
TCDL 7.0	Lumber DOL 1.25	BC 0.52	Vert(CT) -0.29 14-15 >999 180		
BCLL 0.0 *	Rep Stress Incr YES	WB 0.83	Horz(CT) 0.14 11 n/a n/a		
BCDL 10.0	Code FBC2020/TPI2014	Matrix-MS		Weight: 219 lb	FT = 20%

LUMBER-	BRACING-
TOP CHORD 2x4 SP No.2	TOP CHORD Structural wood sheathing directly applied or 3-6-11 oc purlins, except end verticals.
BOT CHORD 2x4 SP No.2	BOT CHORD Rigid ceiling directly applied or 4-0-1 oc bracing.
WEBS 2x4 SP No.3	

REACTIONS. (size) 11=0-3-0, 2=0-3-8, 17=0-3-8
 Max Horz 2=268(LC 11)
 Max Uplift 11=-239(LC 13), 2=-319(LC 19), 17=-419(LC 12)
 Max Grav 11=968(LC 1), 2=113(LC 13), 17=2061(LC 1)

FORCES. (lb) - Max. Comp./Max. Ten. - All forces 250 (lb) or less except when shown.
 TOP CHORD 2-3=-591/1628, 3-4=-707/212, 4-5=-2028/662, 5-6=-1996/767, 6-7=-2102/640,
 7-8=-1726/491, 8-9=-650/244, 9-10=-650/244, 10-11=-927/269
 BOT CHORD 2-17=-1478/295, 16-17=-1708/368, 15-16=-352/760, 14-15=-525/1396, 13-14=-352/1117,
 12-13=-325/1020
 WEBS 3-17=-1253/481, 3-16=-616/2173, 4-16=-990/376, 4-15=-351/1014, 5-15=-252/198,
 6-15=-549/1235, 6-14=-361/930, 7-14=-1254/426, 8-14=-289/883, 8-13=-334/155,
 8-12=-601/175, 10-12=-281/1041

- NOTES-**
- Unbalanced roof live loads have been considered for this design.
 - Wind: ASCE 7-16; Vult=130mph (3-second gust) Vasd=101mph; TCDL=4.2psf; BCDL=3.0psf; h=20ft; Cat. II; Exp B; Encl., GCpi=0.18; MWFRS (envelope) gable end zone and C-C Exterior(2E) -1-6-0 to 2-2-12, Interior(1) 2-2-12 to 19-0-0, Exterior(2E) 19-0-0 to 22-11-2, Interior(1) 22-11-2 to 37-1-12 zone; end vertical right exposed; porch left exposed; C-C for members and forces & MWFRS for reactions shown; Lumber DOL=1.60 plate grip DOL=1.60
 - Building Designer / Project engineer responsible for verifying applied roof live load shown covers rain loading requirements specific to the use of this truss component.
 - Provide adequate drainage to prevent water ponding.
 - This truss has been designed for a 10.0 psf bottom chord live load nonconcurrent with any other live loads.
 - * This truss has been designed for a live load of 20.0psf on the bottom chord in all areas where a rectangle 3-6-0 tall by 2-0-0 wide will fit between the bottom chord and any other members.
 - Provide mechanical connection (by others) of truss to bearing plate capable of withstanding 100 lb uplift at joint(s) except (jt=lb) 11=239, 2=319, 17=419.

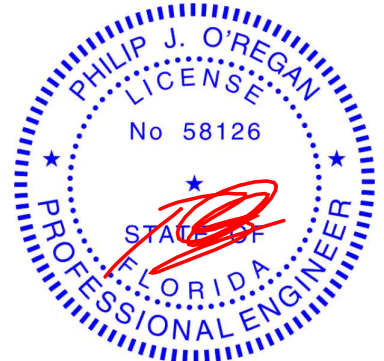

Philip J. O'Regan PE No.58126
 MiTek USA, Inc. FL Cert 6634
 6904 Parke East Blvd. Tampa FL 33610
 Date: September 7, 2021

Job	Truss	Truss Type	Qty	Ply	IC CONST. - LIBERTY RES.	T25256442
2918935	T20	Roof Special	1	1		

Builders FirstSource (Lake City, FL), Lake City, FL - 32055,

8.430 s Aug 16 2021 MiTek Industries, Inc. Sat Sep 4 11:23:58 2021 Page 1

ID:b2ldsklJGjOxOjHDJpp?LTyh2aU-8QHzCU0ELKTCh91wn3RUsoXn7iO7fiApUBMcWsyh11V

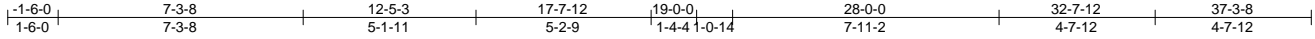

Scale = 1:68.6

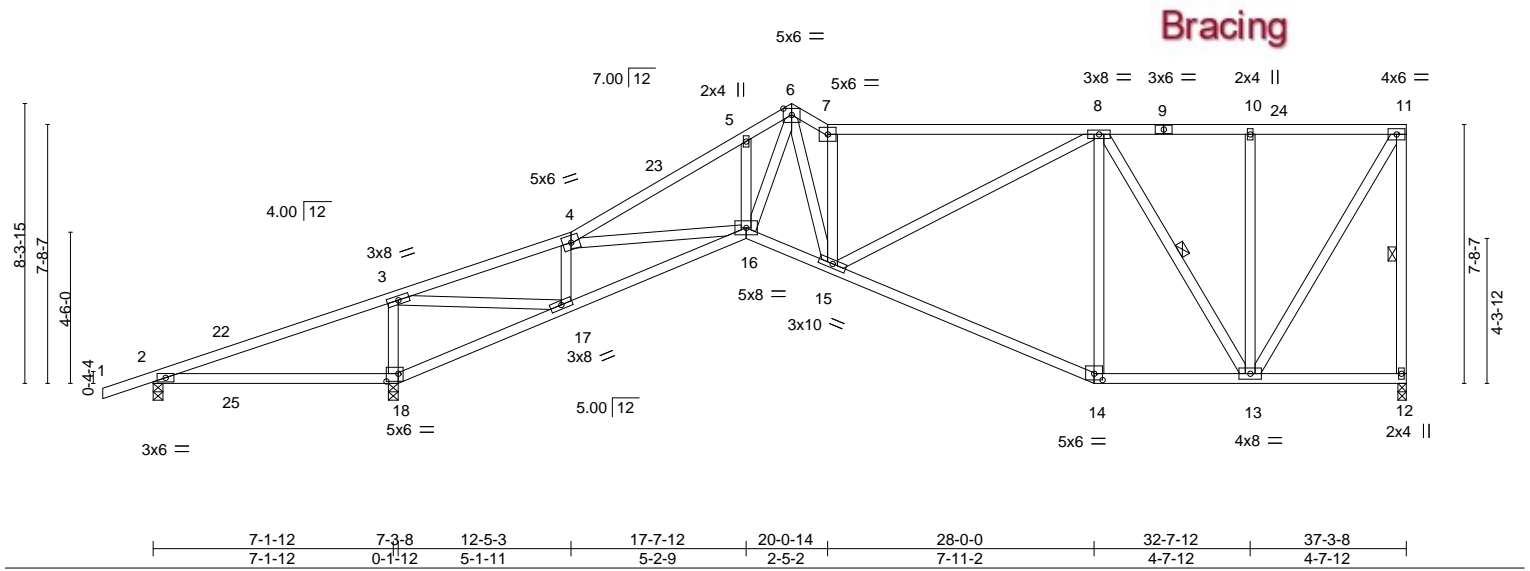

Plate Offsets (X,Y)--	[14-0-3-0,0-2-4], [18-0-4-4,0-2-12]
-----------------------	-------------------------------------

LOADING (psf)	SPACING-	CSI.	DEFL.	PLATES	GRIP
TCLL 20.0	2-0-0	TC 0.85	in (loc) l/defl L/d	MT20	244/190
TCDL 7.0	Plate Grip DOL 1.25	BC 0.64	Vert(LL) 0.20 18-21 >428 240		
BCLL 0.0 *	Lumber DOL 1.25	WB 0.83	Vert(CT) -0.36 14-15 >999 180		
BCDL 10.0	Rep Stress Incr YES	Matrix-MS	Horz(CT) 0.14 12 n/a n/a		
	Code FBC2020/TP12014			Weight: 231 lb	FT = 20%

LUMBER-	BRACING-
TOP CHORD 2x4 SP No.2	TOP CHORD Structural wood sheathing directly applied or 2-2-0 oc purlins, except end verticals.
BOT CHORD 2x4 SP No.2	BOT CHORD Rigid ceiling directly applied or 4-1-7 oc bracing.
WEBS 2x4 SP No.3	WEBS 1 Row at midpt 11-12, 8-13

REACTIONS. (size) 12=0-3-0, 2=0-3-8, 18=0-3-8
 Max Horz 2=287(LC 11)
 Max Uplift 12=-252(LC 13), 2=-300(LC 19), 18=-418(LC 12)
 Max Grav 12=974(LC 1), 2=133(LC 13), 18=2032(LC 1)

FORCES. (lb) - Max. Comp./Max. Ten. - All forces 250 (lb) or less except when shown.
 TOP CHORD 2-3=-652/1557, 3-4=-782/218, 4-5=-2065/690, 5-6=-2037/801, 6-7=-1774/582,
 7-8=-1459/460, 8-10=-501/227, 10-11=-501/227, 11-12=-931/278
 BOT CHORD 2-18=-1411/274, 17-18=-1635/346, 16-17=-415/831, 15-16=-602/1411, 14-15=-326/917,
 13-14=-297/821
 WEBS 3-18=-1254/496, 3-17=-653/2176, 4-17=-985/396, 4-16=-395/975, 5-16=-254/211,
 6-16=-641/1221, 6-15=-295/806, 7-15=-1151/425, 8-15=-309/726, 8-13=-616/195,
 11-13=-270/954

- NOTES-**
- Unbalanced roof live loads have been considered for this design.
 - Wind: ASCE 7-16; Vult=130mph (3-second gust) Vasd=101mph; TCdL=4.2psf; BCDL=3.0psf; h=20ft; Cat. II; Exp B; Encl., GCpi=0.18; MWFRS (envelope) gable end zone and C-C Exterior(2E) -1-6-0 to 2-2-12, Interior(1) 2-2-12 to 19-0-0, Exterior(2E) 19-0-0 to 20-0-14, Interior(1) 20-0-14 to 37-1-12 zone; end vertical right exposed; porch left exposed; C-C for members and forces & MWFRS for reactions shown; Lumber DOL=1.60 plate grip DOL=1.60
 - Building Designer / Project engineer responsible for verifying applied roof live load shown covers rain loading requirements specific to the use of this truss component.
 - Provide adequate drainage to prevent water ponding.
 - This truss has been designed for a 10.0 psf bottom chord live load nonconcurrent with any other live loads.
 - * This truss has been designed for a live load of 20.0psf on the bottom chord in all areas where a rectangle 3-6-0 tall by 2-0-0 wide will fit between the bottom chord and any other members.
 - Provide mechanical connection (by others) of truss to bearing plate capable of withstanding 100 lb uplift at joint(s) except (jt=lb) 12=252, 2=300, 18=418.



Philip J. O'Regan PE No.58126
 MiTek USA, Inc. FL Cert 6634
 6904 Parke East Blvd. Tampa FL 33610
 Date: September 7, 2021

WARNING - Verify design parameters and READ NOTES ON THIS AND INCLUDED MITEK REFERENCE PAGE MII-7473 rev. 5/19/2020 BEFORE USE.
 Design valid for use only with MiTek® connectors. This design is based only upon parameters shown, and is for an individual building component, not a truss system. Before use, the building designer must verify the applicability of design parameters and properly incorporate this design into the overall building design. Bracing indicated is to prevent buckling of individual truss web and/or chord members only. Additional temporary and permanent bracing is always required for stability and to prevent collapse with possible personal injury and property damage. For general guidance regarding the fabrication, storage, delivery, erection and bracing of trusses and truss systems, see **ANSI/TP1 Quality Criteria, DSB-89 and BCSI Building Component Safety Information** available from Truss Plate Institute, 2670 Crain Highway, Suite 203 Waldorf, MD 20601



6904 Parke East Blvd.
 Tampa, FL 33610

Job	Truss	Truss Type	Qty	Ply	IC CONST. - LIBERTY RES.	T25256443
2918935	T21	Half Hip	1	1		

Builders FirstSource (Lake City, FL), Lake City, FL - 32055, 8.430 s Aug 16 2021 MiTek Industries, Inc. Sat Sep 4 11:23:59 2021 Page 1
 ID:b2ldskJGjOxOjHDJPP?LTyh2aU-cdqMPq1t6eb3Jc6LmyjPb4xoGjcOAHZjr5A2Jyh11U



Bracing

Scale = 1:67.4

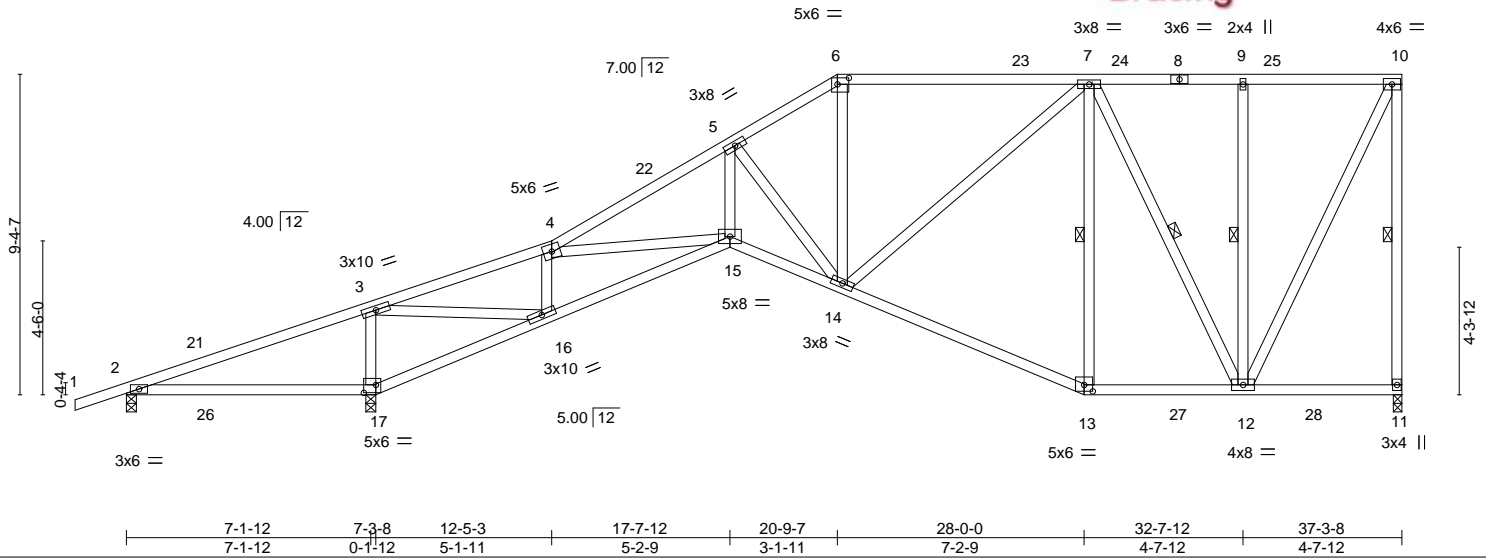

Plate Offsets (X,Y)--	[6:0-4-0-0-2-4], [13:0-3-0-0-2-4], [17:0-4-4-0-2-12]
-----------------------	--

LOADING (psf)	SPACING-	CSI.	DEFL.	PLATES	GRIP
TCLL 20.0	2-0-0	TC 0.92	in (loc) l/defl L/d	MT20	244/190
TCDL 7.0	Plate Grip DOL 1.25	BC 0.69	Vert(LL) 0.21 17-20 >426 240		
BCLL 0.0 *	Lumber DOL 1.25	WB 0.90	Vert(CT) -0.31 13-14 >999 180		
BCDL 10.0	Rep Stress Incr YES	Matrix-MS	Horz(CT) 0.16 11 n/a n/a		
	Code FBC2020/TPI2014			Weight: 242 lb	FT = 20%

LUMBER-	BRACING-
TOP CHORD 2x4 SP No.2	TOP CHORD Structural wood sheathing directly applied or 3-5-1 oc purlins, except end verticals.
BOT CHORD 2x4 SP No.2	BOT CHORD Rigid ceiling directly applied or 3-7-5 oc bracing.
WEBS 2x4 SP No.3	WEBS 1 Row at midpt 10-11, 7-13, 7-12, 9-12

REACTIONS. (size) 11=0-3-0, 2=0-3-8, 17=0-3-8
 Max Horz 2=330(LC 11)
 Max Uplift 11=-258(LC 9), 2=-340(LC 19), 17=-534(LC 12)
 Max Grav 11=1105(LC 2), 2=109(LC 13), 17=2185(LC 2)

FORCES. (lb) - Max. Comp./Max. Ten. - All forces 250 (lb) or less except when shown.
 TOP CHORD 2-3=-748/1662, 3-4=-872/241, 4-5=-2222/707, 5-6=-1315/408, 6-7=-1117/376,
 7-9=-461/238, 9-10=-461/238, 10-11=-1012/306
 BOT CHORD 2-17=-1518/311, 16-17=-1766/372, 15-16=-461/933, 14-15=-948/2036, 13-14=-312/844,
 12-13=-284/732
 WEBS 3-17=-1279/515, 3-16=-700/2370, 4-16=-992/418, 4-15=-453/1035, 5-15=-532/1252,
 5-14=-1314/643, 6-14=-62/427, 7-14=-260/539, 7-12=-611/204, 10-12=-283/1027

- NOTES-**
- Unbalanced roof live loads have been considered for this design.
 - Wind: ASCE 7-16; Vult=130mph (3-second gust) Vasd=101mph; TC DL=4.2psf; BCDL=3.0psf; h=20ft; Cat. II; Exp B; Encl., GCpi=0.18; MWFRS (envelope) gable end zone and C-C Exterior(2E) -1-6-0 to 2-2-12, Interior(1) 2-2-12 to 20-9-7, Exterior(2R) 20-9-7 to 26-0-12, Interior(1) 26-0-12 to 37-1-12 zone; end vertical right exposed; porch left exposed; C-C for members and forces & MWFRS for reactions shown; Lumber DOL=1.60 plate grip DOL=1.60
 - Building Designer / Project engineer responsible for verifying applied roof live load shown covers rain loading requirements specific to the use of this truss component.
 - Provide adequate drainage to prevent water ponding.
 - This truss has been designed for a 10.0 psf bottom chord live load nonconcurrent with any other live loads.
 - * This truss has been designed for a live load of 20.0psf on the bottom chord in all areas where a rectangle 3-6-0 tall by 2-0-0 wide will fit between the bottom chord and any other members, with BCDL = 10.0psf.
 - Provide mechanical connection (by others) of truss to bearing plate capable of withstanding 100 lb uplift at joint(s) except (jt=lb) 11=258, 2=340, 17=534.

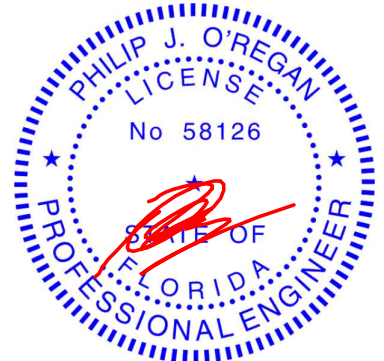

Philip J. O'Regan PE No.58126
 MiTek USA, Inc. FL Cert 6634
 6904 Parke East Blvd. Tampa FL 33610
 Date: September 7, 2021

Job	Truss	Truss Type	Qty	Ply	IC CONST. - LIBERTY RES.	T25256444
2918935	T22	Half Hip	1	1		

Builders FirstSource (Lake City,FL), Lake City, FL - 32055,

8.430 s Aug 16 2021 MiTek Industries, Inc. Sat Sep 4 11:24:00 2021 Page 1

ID:b2ldskJJGjOxOjHDJPP?LTyh2aU-5pOkdA2VtyjwwTBLuUTyxp6vg3R7da6yVrjalYh11T

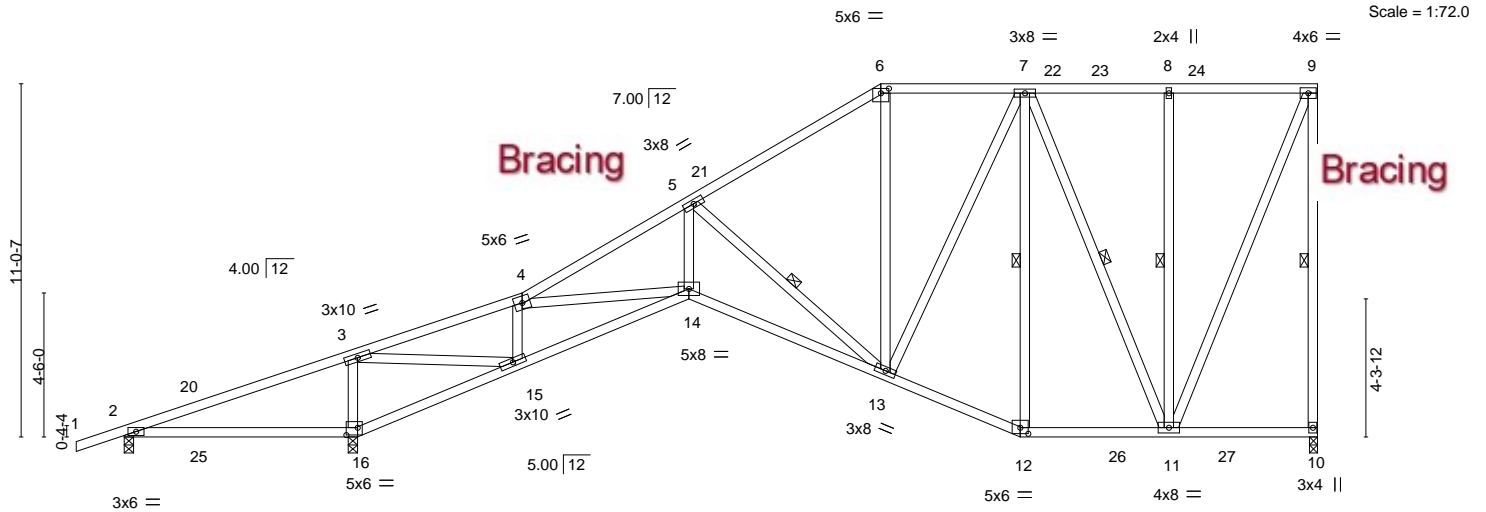

Plate Offsets (X,Y)-- [6:0-3-0,0-1-12], [12:0-3-0,0-2-4], [16:0-4-4,0-2-12]

LOADING (psf)	SPACING-	CSI.	DEFL.	PLATES	GRIP
TCLL 20.0	Plate Grip DOL 1.25	TC 0.90	in (loc) l/defl L/d	MT20	244/190
TCDL 7.0	Lumber DOL 1.25	BC 0.65	Vert(LL) 0.21 16-19 >425 240		
BCLL 0.0 *	Rep Stress Incr YES	WB 0.90	Vert(CT) -0.33 13-14 >999 180		
BCDL 10.0	Code FBC2020/TP12014	Matrix-MS	Horz(CT) 0.18 10 n/a n/a		
				Weight: 264 lb	FT = 20%

LUMBER-

TOP CHORD 2x4 SP No.2
 BOT CHORD 2x4 SP No.2
 WEBS 2x4 SP No.3 *Except*
 9-10: 2x4 SP No.2

BRACING-

TOP CHORD Structural wood sheathing directly applied or 3-8-9 oc purlins, except end verticals.
 BOT CHORD Rigid ceiling directly applied or 3-4-15 oc bracing.
 WEBS 1 Row at midpt 9-10, 5-13, 7-12, 7-11, 8-11

REACTIONS.

(size) 10=0-3-0, 2=0-3-8, 16=0-3-8
 Max Horz 2=386(LC 11)
 Max Uplift 10=-252(LC 9), 2=-417(LC 19), 16=-557(LC 12)
 Max Grav 10=1102(LC 2), 2=129(LC 13), 16=2238(LC 2)

FORCES. (lb) - Max. Comp./Max. Ten. - All forces 250 (lb) or less except when shown.

TOP CHORD 2-3=-866/1889, 3-4=-795/205, 4-5=-2182/659, 5-6=-982/343, 6-7=-789/337,
 7-8=-416/246, 8-9=-416/246, 9-10=-1011/322
 BOT CHORD 2-16=-1663/346, 15-16=-1912/410, 14-15=-419/821, 13-14=-999/2143, 12-13=-298/683,
 11-12=-275/598
 WEBS 3-16=-1279/518, 3-15=-696/2394, 4-15=-1005/414, 4-14=-536/1217, 5-14=-523/1324,
 5-13=-1539/712, 6-13=-33/258, 7-13=-250/511, 7-11=-535/204, 8-11=-264/152,
 9-11=-303/1004

NOTES-

- 1) Wind: ASCE 7-16; Vult=130mph (3-second gust) Vasd=101mph; TC DL=4.2psf; BCDL=3.0psf; h=20ft; Cat. II; Exp B; Encl., GCpi=0.18; MWFRS (envelope) gable end zone and C-C Exterior(2E) -1-6-0 to 2-2-12, Interior(1) 2-2-12 to 23-7-12, Exterior(2R) 23-7-12 to 28-11-0, Interior(1) 28-11-0 to 37-1-12 zone; end vertical right exposed; porch left exposed; C-C for members and forces & MWFRS for reactions shown; Lumber DOL=1.60 plate grip DOL=1.60
- 2) Building Designer / Project engineer responsible for verifying applied roof live load shown covers rain loading requirements specific to the use of this truss component.
- 3) Provide adequate drainage to prevent water ponding.
- 4) This truss has been designed for a 10.0 psf bottom chord live load nonconcurrent with any other live loads.
- 5) * This truss has been designed for a live load of 20.0psf on the bottom chord in all areas where a rectangle 3-6-0 tall by 2-0-0 wide will fit between the bottom chord and any other members, with BCDL = 10.0psf.
- 6) Provide mechanical connection (by others) of truss to bearing plate capable of withstanding 100 lb uplift at joint(s) except (jt=lb) 10=252, 2=417, 16=557.

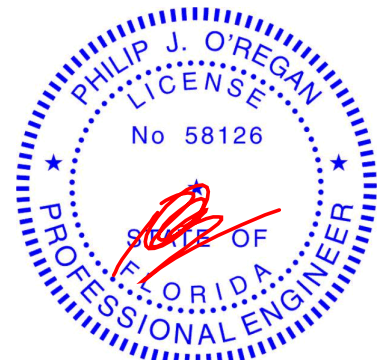

Philip J. O'Regan PE No.58126
 MiTek USA, Inc. FL Cert 6634
 6904 Parke East Blvd. Tampa FL 33610
 Date:

September 7, 2021

WARNING - Verify design parameters and READ NOTES ON THIS AND INCLUDED MITEK REFERENCE PAGE MII-7473 rev. 5/19/2020 BEFORE USE.

Design valid for use only with MiTek® connectors. This design is based only upon parameters shown, and is for an individual building component, not a truss system. Before use, the building designer must verify the applicability of design parameters and properly incorporate this design into the overall building design. Bracing indicated is to prevent buckling of individual truss web and/or chord members only. Additional temporary and permanent bracing is always required for stability and to prevent collapse with possible personal injury and property damage. For general guidance regarding the fabrication, storage, delivery, erection and bracing of trusses and truss systems, see

ANSI/TP1 Quality Criteria, DSB-89 and BCSI Building Component

Safety Information available from Truss Plate Institute, 2670 Crain Highway, Suite 203 Waldorf, MD 20601



6904 Parke East Blvd.
 Tampa, FL 36610

Job 2918935	Truss T23	Truss Type Piggyback Base	Qty 2	Ply 1	IC CONST. - LIBERTY RES.	T25256445
----------------	--------------	------------------------------	----------	----------	--------------------------	-----------

Builders FirstSource (Lake City, FL), Lake City, FL - 32055,

8.430 s Aug 16 2021 MiTek Industries, Inc. Sat Sep 4 11:24:02 2021 Page 1

ID:b2ldskJGjOxOjHDJPP?LTyh2aU-1CWU2r3IPZzdAmLh0vVQ0EiRgUkBBYOPPPkqfyh11R

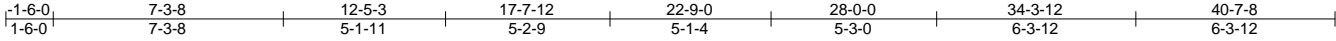

Scale = 1:73.0

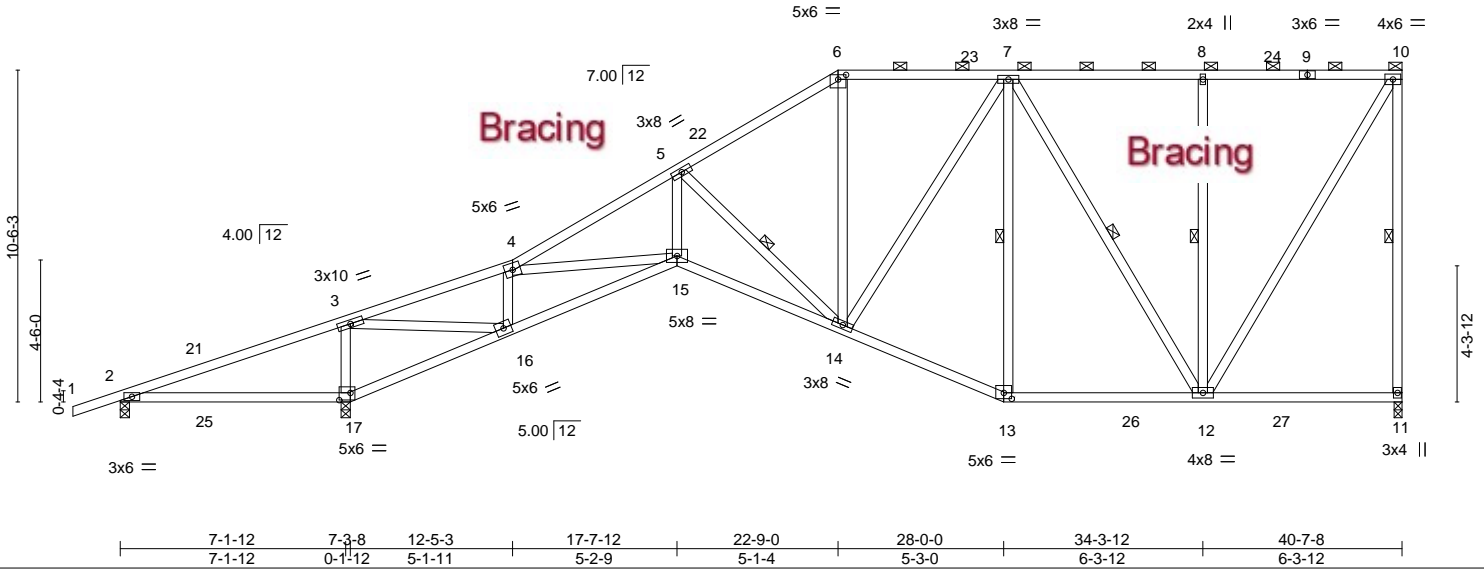

Plate Offsets (X,Y)--	[6:0-3-0,0-1-12], [13:0-3-0,0-2-4], [17:0-4-4,0-2-12]
-----------------------	---

LOADING (psf)	SPACING-	CSI.	DEFL.	PLATES	GRIP
TCLL 20.0	Plate Grip DOL 1.25	TC 0.95	in (loc) l/defl L/d	MT20	244/190
TCDL 7.0	Lumber DOL 1.25	BC 0.70	Vert(LL) 0.21 17-20 >424 240		
BCLL 0.0 *	Rep Stress Incr YES	WB 0.88	Vert(CT) -0.34 14-15 >999 180		
BCDL 10.0	Code FBC2020/TPI2014	Matrix-MS	Horz(CT) 0.19 11 n/a n/a		
				Weight: 269 lb	FT = 20%

LUMBER-	BRACING-
TOP CHORD 2x4 SP No.2	TOP CHORD Structural wood sheathing directly applied or 2-2-0 oc purlins, except end verticals, and 2-0-0 oc purlins (5-5-15 max.): 6-10.
BOT CHORD 2x4 SP No.2	BOT CHORD Rigid ceiling directly applied or 3-0-7 oc bracing.
WEBS 2x4 SP No.3 *Except* 10-11,3-16: 2x4 SP No.2	WEBS 1 Row at midpt 10-11, 5-14, 7-13, 7-12, 8-12

REACTIONS. (size) 11=0-3-0, 2=0-3-8, 17=0-3-8
 Max Horz 2=369(LC 11)
 Max Uplift 11=-287(LC 9), 2=-476(LC 19), 17=-506(LC 12)
 Max Grav 11=1252(LC 2), 2=122(LC 13), 17=2463(LC 2)

FORCES. (lb) - Max. Comp./Max. Ten. - All forces 250 (lb) or less except when shown.
 TOP CHORD 2-3=-887/2069, 3-4=-842/221, 4-5=-2519/741, 5-6=-1289/407, 6-7=-1067/387,
 7-8=-637/287, 8-10=-637/287, 10-11=-1128/334
 BOT CHORD 2-17=-1875/365, 16-17=-2162/448, 15-16=-432/880, 14-15=-1036/2362, 13-14=-365/978,
 12-13=-334/870
 WEBS 3-17=-1401/542, 3-16=-759/2668, 4-16=-1147/446, 4-15=-560/1371, 5-15=-547/1417,
 5-14=-1574/697, 6-14=-70/411, 7-14=-219/435, 7-12=-488/178, 8-12=-367/192,
 10-12=-324/1183

- NOTES-**
- Unbalanced roof live loads have been considered for this design.
 - Wind: ASCE 7-16; Vult=130mph (3-second gust) Vasd=101mph; TCDL=4.2psf; BCDL=3.0psf; h=20ft; Cat. II; Exp B; Encl., GCpi=0.18; MWFRS (envelope) gable end zone and C-C Exterior(2E) -1-6-0 to 2-6-12, Interior(1) 2-6-12 to 22-9-0, Exterior(2R) 22-9-0 to 26-9-12, Interior(1) 26-9-12 to 40-5-12 zone; end vertical rigid exposed; porch left exposed; C-C for members and forces & MWFRS for reactions shown; Lumber DOL=1.60 plate grip DOL=1.60
 - Building Designer / Project engineer responsible for verifying applied roof live load shown covers rain loading requirements specific to the use of this truss component.
 - Provide adequate drainage to prevent water ponding.
 - This truss has been designed for a 10.0 psf bottom chord live load nonconcurrent with any other live loads.
 - * This truss has been designed for a live load of 20.0psf on the bottom chord in all areas where a rectangle 3-6-0 tall by 2-0-0 wide will fit between the bottom chord and any other members, with BCDL = 10.0psf.
 - Provide mechanical connection (by others) of truss to bearing plate capable of withstanding 100 lb uplift at joint(s) except (jt=lb) 11=287, 2=476, 17=506.
 - Graphical purlin representation does not depict the size or the orientation of the purlin along the top and/or bottom chord.

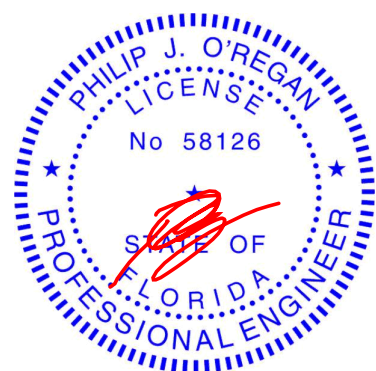

Philip J. O'Regan PE No.58126
 MiTek USA, Inc. FL Cert 6634
 6904 Parke East Blvd. Tampa FL 33610
 Date: September 7, 2021

WARNING - Verify design parameters and READ NOTES ON THIS AND INCLUDED MITEK REFERENCE PAGE MII-7473 rev. 5/19/2020 BEFORE USE.
 Design valid for use only with MiTek® connectors. This design is based only upon parameters shown, and is for an individual building component, not a truss system. Before use, the building designer must verify the applicability of design parameters and properly incorporate this design into the overall building design. Bracing indicated is to prevent buckling of individual truss web and/or chord members only. Additional temporary and permanent bracing is always required for stability and to prevent collapse with possible personal injury and property damage. For general guidance regarding the fabrication, storage, delivery, erection and bracing of trusses and truss systems, see **ANSI/TPI1 Quality Criteria, DSB-89 and BCSI Building Component Safety Information** available from Truss Plate Institute, 2670 Crain Highway, Suite 203 Waldorf, MD 20601

6904 Parke East Blvd.
 Tampa, FL 36610

Job	Truss	Truss Type	Qty	Ply	IC CONST. - LIBERTY RES.	T25256446
2918935	T24	Half Hip	1	1		

Builders FirstSource (Lake City, FL), Lake City, FL - 32055, 8.430 s Aug 16 2021 MiTek Industries, Inc. Sat Sep 4 11:24:03 2021 Page 1
 ID: b2ldskJGjOxOjHDJPP?LTyh2aU-VO4sFB4NAt5Unwvtac1fZRFcQu4QK?RYeT3NB4yh11Q

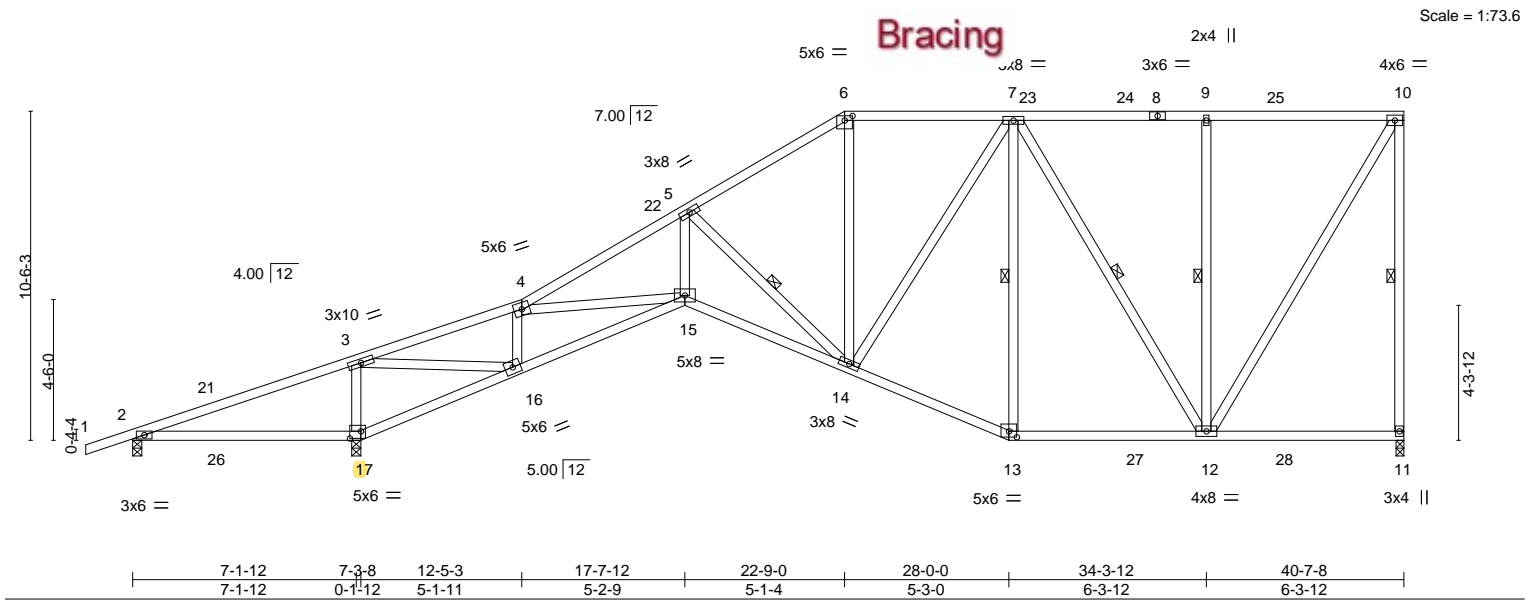
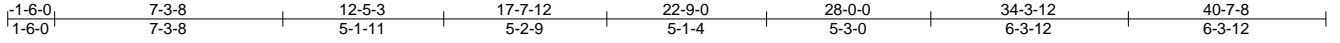

Plate Offsets (X,Y)-- [6:0-3-0,0-1-12], [13:0-3-0,0-2-4], [17:0-4-4,0-2-12]

LOADING (psf)	SPACING-	CSI.	DEFL.	PLATES	GRIP
TCLL 20.0	Plate Grip DOL 1.25	TC 0.95	in (loc) l/defl L/d	MT20	244/190
TCDL 7.0	Lumber DOL 1.25	BC 0.70	Vert(LL) 0.21 17-20 >424 240		
BCLL 0.0 *	Rep Stress Incr YES	WB 0.89	Vert(CT) -0.34 14-15 >999 180		
BCDL 10.0	Code FBC2020/TPI2014	Matrix-MS	Horz(CT) 0.19 11 n/a n/a		
				Weight: 269 lb	FT = 20%

LUMBER-	BRACING-
TOP CHORD 2x4 SP No.2	TOP CHORD Structural wood sheathing directly applied or 2-2-0 oc purlins, except end verticals.
BOT CHORD 2x4 SP No.2	BOT CHORD Rigid ceiling directly applied or 3-0-7 oc bracing.
WEBS 2x4 SP No.3 *Except* 10-11,3-16: 2x4 SP No.2	WEBS 1 Row at midpt 10-11, 5-14, 7-13, 7-12, 9-12

REACTIONS. (size) 11=0-3-0, 2=0-3-8, 17=0-3-8
 Max Horz 2=369(LC 11)
 Max Uplift 11=-287(LC 9), 2=-476(LC 19), 17=-602(LC 12)
 Max Grav 11=1252(LC 2), 2=135(LC 13), 17=2463(LC 2)

FORCES. (lb) - Max. Comp./Max. Ten. - All forces 250 (lb) or less except when shown.
 TOP CHORD 2-3=-916/2069, 3-4=-838/223, 4-5=-2519/768, 5-6=-1289/417, 6-7=-1067/396,
 7-9=-618/291, 9-10=-618/291, 10-11=-1128/338
 BOT CHORD 2-17=-1875/394, 16-17=-2162/469, 15-16=-440/880, 14-15=-1071/2362, 13-14=-370/978,
 12-13=-339/870
 WEBS 3-17=-1401/553, 3-16=-786/2668, 4-16=-1147/459, 4-15=-584/1371, 5-15=-564/1417,
 5-14=-1574/728, 6-14=-74/411, 7-14=-226/435, 7-12=-488/183, 9-12=-367/192,
 10-12=-328/1183

- NOTES-**
- Unbalanced roof live loads have been considered for this design.
 - Wind: ASCE 7-16; Vult=130mph (3-second gust) Vasd=101mph; TC DL=4.2psf; BCDL=3.0psf; h=20ft; Cat. II; Exp B; Encl., GCpi=0.18; MWFRS (envelope) gable end zone and C-C Exterior(2E) -1-6-0 to 2-6-12, Interior(1) 2-6-12 to 22-9-0, Exterior(2R) 22-9-0 to 28-5-15, Interior(1) 28-5-15 to 40-5-12 zone; end vertical rigid exposed; porch left exposed; C-C for members and forces & MWFRS for reactions shown; Lumber DOL=1.60 plate grip DOL=1.60
 - Building Designer / Project engineer responsible for verifying applied roof live load shown covers rain loading requirements specific to the use of this truss component.
 - Provide adequate drainage to prevent water ponding.
 - This truss has been designed for a 10.0 psf bottom chord live load nonconcurrent with any other live loads.
 - * This truss has been designed for a live load of 20.0psf on the bottom chord in all areas where a rectangle 3-6-0 tall by 2-0-0 wide will fit between the bottom chord and any other members, with BCDL = 10.0psf.
 - Provide mechanical connection (by others) of truss to bearing plate capable of withstanding 100 lb uplift at joint(s) except (jt=lb) 11=287, 2=476, 17=602.

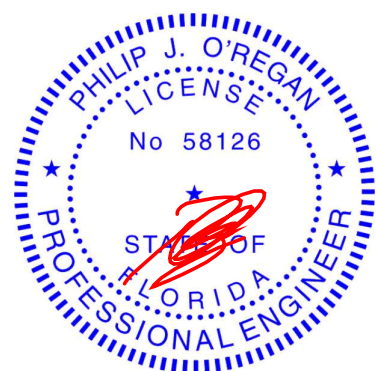

Philip J. O'Regan PE No.58126
 MiTek USA, Inc. FL Cert 6634
 6904 Parke East Blvd. Tampa FL 33610
 Date: September 7, 2021

WARNING - Verify design parameters and READ NOTES ON THIS AND INCLUDED MITEK REFERENCE PAGE MII-7473 rev. 5/19/2020 BEFORE USE.
 Design valid for use only with MiTek® connectors. This design is based only upon parameters shown, and is for an individual building component, not a truss system. Before use, the building designer must verify the applicability of design parameters and properly incorporate this design into the overall building design. Bracing indicated is to prevent buckling of individual truss web and/or chord members only. Additional temporary and permanent bracing is always required for stability and to prevent collapse with possible personal injury and property damage. For general guidance regarding the fabrication, storage, delivery, erection and bracing of trusses and truss systems, see ANSITPI1 Quality Criteria, DSB-89 and BCSI Building Component Safety Information available from Truss Plate Institute, 2670 Crain Highway, Suite 203 Waldorf, MD 20601



6904 Parke East Blvd.
 Tampa, FL 33610

Job	Truss	Truss Type	Qty	Ply	IC CONST. - LIBERTY RES.	T25256448
2918935	T26	Roof Special	1	1		

Builders FirstSource (Lake City, FL), Lake City, FL - 32055,

8.430 s Aug 16 2021 MiTek Industries, Inc. Sat Sep 4 11:24:06 2021 Page 1

ID:b2ldskJGjOxOjHDJpp?LTyh2aU-vzm?iD6GSoU3eOeSFkaMB4t7k568XQI?KR11oPyh11N

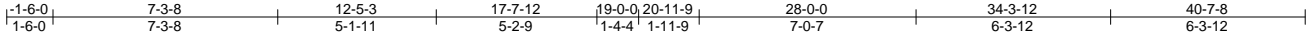

Scale = 1:74.7

Bracing

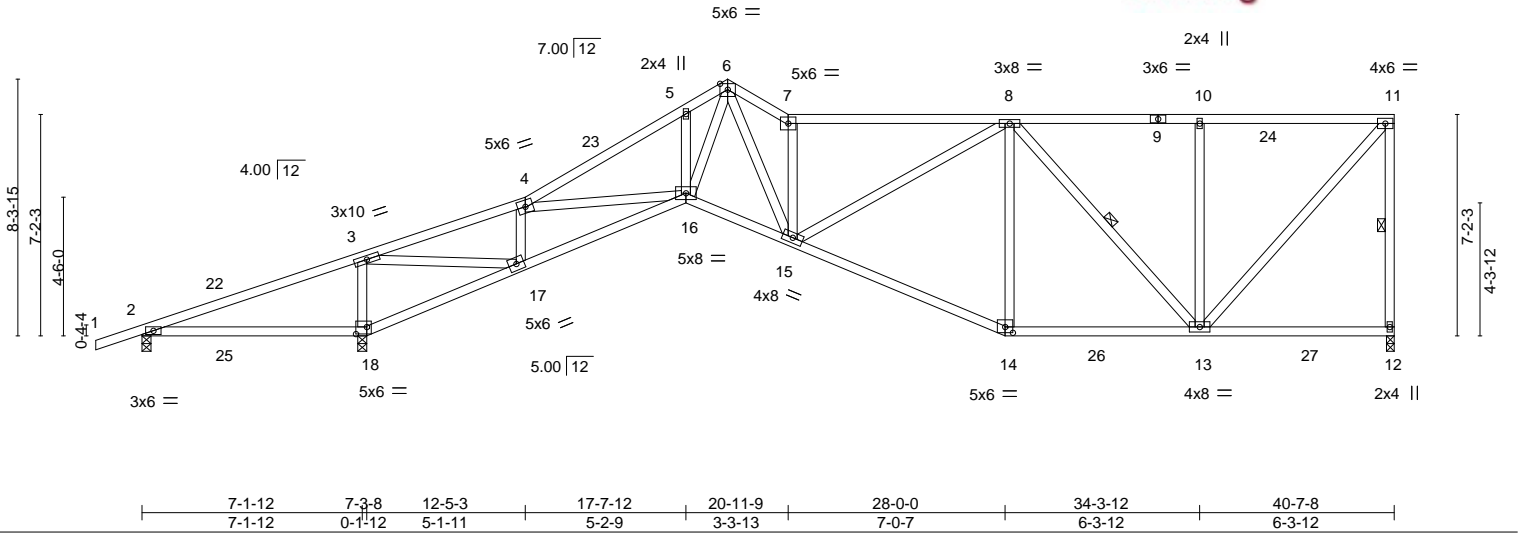

Plate Offsets (X,Y)--	[14:0-3-0,0-2-4], [18:0-4-4,0-2-12]
-----------------------	-------------------------------------

LOADING (psf)	SPACING-	CSI.	DEFL.	PLATES	GRIP
TCLL 20.0	Plate Grip DOL 1.25	TC 0.94	in (loc) l/defl L/d	MT20	244/190
TCDL 7.0	Lumber DOL 1.25	BC 0.69	Vert(LL) 0.21 18-21 >426 240		
BCLL 0.0 *	Rep Stress Incr YES	WB 0.60	Vert(CT) -0.41 14-15 >961 180		
BCDL 10.0	Code FBC2020/TPI2014	Matrix-MS	Horz(CT) 0.18 12 n/a n/a		
				Weight: 240 lb	FT = 20%

LUMBER-	BRACING-
TOP CHORD 2x4 SP No.2	TOP CHORD Structural wood sheathing directly applied or 2-2-0 oc purlins, except end verticals.
BOT CHORD 2x4 SP No.2	BOT CHORD Rigid ceiling directly applied or 3-0-12 oc bracing.
WEBS 2x4 SP No.3 *Except* 3-17: 2x4 SP No.2	WEBS 1 Row at midpt 11-12, 8-13

REACTIONS. (size) 12=0-3-0, 2=0-3-8, 18=0-3-8
 Max Horz 2=281(LC 11)
 Max Uplift 12=-280(LC 13), 2=-468(LC 19), 18=-442(LC 12)
 Max Grav 12=1226(LC 2), 2=152(LC 13), 18=2452(LC 2)

FORCES. (lb) - Max. Comp./Max. Ten. - All forces 250 (lb) or less except when shown.
 TOP CHORD 2-3=-721/2045, 3-4=-795/210, 4-5=-2491/754, 5-6=-2463/868, 6-7=-2381/671,
 7-8=-1994/537, 8-10=-894/296, 10-11=-894/296, 11-12=-1106/308
 BOT CHORD 2-18=-1862/364, 17-18=-2147/445, 16-17=-390/882, 15-16=-634/1770, 14-15=-417/1438,
 13-14=-382/1288
 WEBS 3-18=-1395/522, 3-17=-718/2658, 4-17=-1140/428, 4-16=-449/1345, 5-16=-250/216,
 6-16=-642/1490, 6-15=-358/1125, 7-15=-1362/446, 8-15=-296/835, 8-14=-360/191,
 8-13=-590/170, 10-13=-344/173, 11-13=-324/1322

- NOTES-**
- Unbalanced roof live loads have been considered for this design.
 - Wind: ASCE 7-16; Vult=130mph (3-second gust) Vasd=101mph; TC DL=4.2psf; BCDL=3.0psf; h=20ft; Cat. II; Exp B; Encl., GCpi=0.18; MWFRS (envelope) gable end zone and C-C Exterior(2E) -1-6-0 to 2-6-12, Interior(1) 2-6-12 to 19-0-0, Exterior(2E) 19-0-0 to 20-11-9, Interior(1) 20-11-9 to 40-5-12 zone; end vertical rigid exposed; porch left exposed; C-C for members and forces & MWFRS for reactions shown; Lumber DOL=1.60 plate grip DOL=1.60
 - Building Designer / Project engineer responsible for verifying applied roof live load shown covers rain loading requirements specific to the use of this truss component.
 - Provide adequate drainage to prevent water ponding.
 - This truss has been designed for a 10.0 psf bottom chord live load nonconcurrent with any other live loads.
 - * This truss has been designed for a live load of 20.0psf on the bottom chord in all areas where a rectangle 3-6-0 tall by 2-0-0 wide will fit between the bottom chord and any other members, with BCDL = 10.0psf.
 - Provide mechanical connection (by others) of truss to bearing plate capable of withstanding 100 lb uplift at joint(s) except (jt=lb) 12=280, 2=468, 18=442.

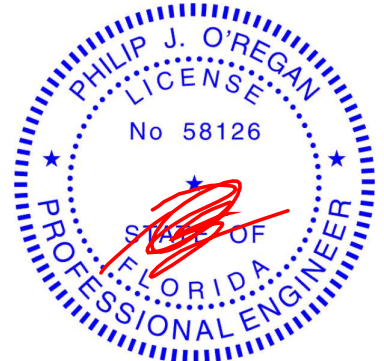

Philip J. O'Regan PE No.58126
 MiTek USA, Inc. FL Cert 6634
 6904 Parke East Blvd. Tampa FL 33610
 Date: September 7, 2021

Job 2918935	Truss T27	Truss Type Roof Special	Qty 1	Ply 1	IC CONST. - LIBERTY RES. Job Reference (optional)	T25256449
----------------	--------------	----------------------------	----------	----------	--	-----------

Builders FirstSource (Lake City, FL), Lake City, FL - 32055,

8.430 s Aug 16 2021 MiTek Industries, Inc. Sat Sep 4 11:24:07 2021 Page 1

ID:b2ldskJGjOxOjHDJPP?LTyh2aU-O9JN5Z7uD5cwGYDepS5bjHPH8VT9Gov8Z51bKryh11M

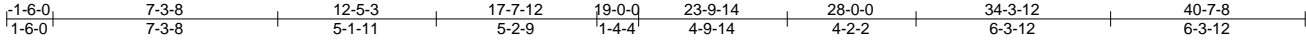

Scale = 1:74.7

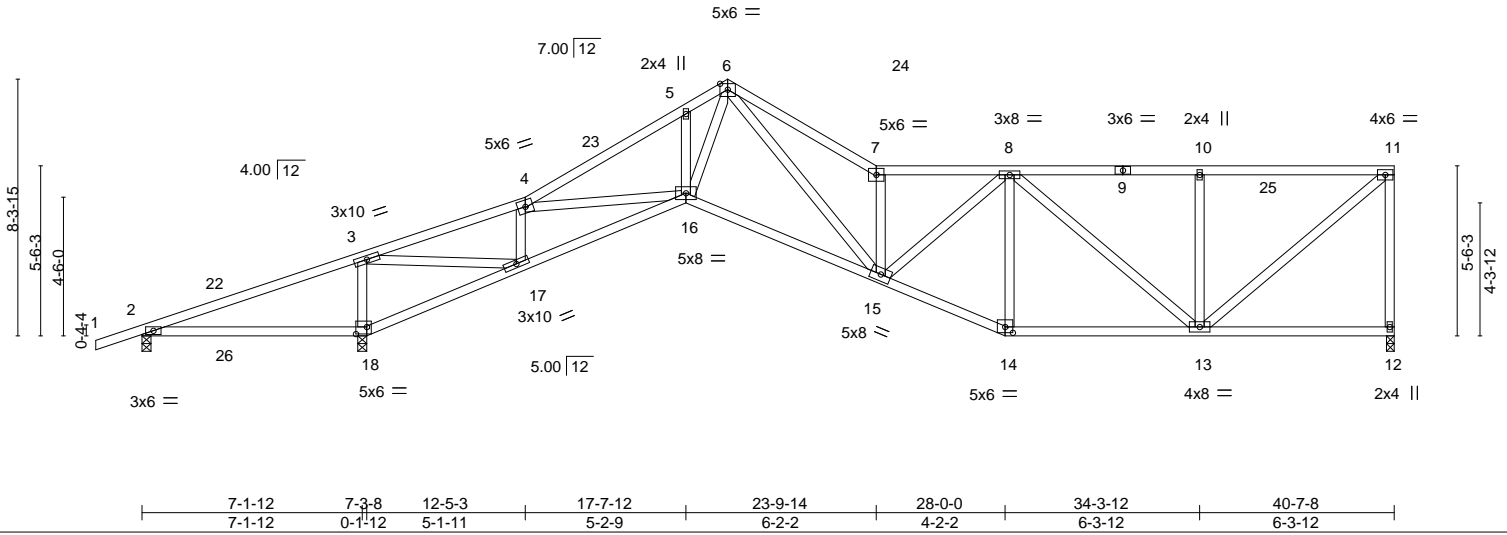

Plate Offsets (X,Y)-- [14:0-3-0,0-2-4], [18:0-4-4,0-2-12]

LOADING (psf)	SPACING-	CSI.	DEFL.	PLATES	GRIP
TCLL 20.0	Plate Grip DOL 1.25	TC 0.96	in (loc) l/defl L/d	MT20	244/190
TCDL 7.0	Lumber DOL 1.25	BC 0.58	Vert(LL) 0.20 18-21 >427 240		
BCLL 0.0 *	Rep Stress Incr YES	WB 0.93	Vert(CT) -0.42 15-16 >949 180		
BCDL 10.0	Code FBC2020/TPI2014	Matrix-MS	Horz(CT) 0.16 12 n/a n/a		
				Weight: 229 lb	FT = 20%

LUMBER-
 TOP CHORD 2x4 SP No.2
 BOT CHORD 2x4 SP No.2
 WEBS 2x4 SP No.3

BRACING-
 TOP CHORD Structural wood sheathing directly applied or 2-2-0 oc purlins, except end verticals.
 BOT CHORD Rigid ceiling directly applied or 3-5-6 oc bracing.

REACTIONS. (size) 12=0-3-0, 2=0-3-8, 18=0-3-8
 Max Horz 2=262(LC 11)
 Max Uplift 12=-270(LC 13), 2=-418(LC 19), 18=-446(LC 12)
 Max Grav 12=1078(LC 1), 2=135(LC 13), 18=2322(LC 1)

FORCES. (lb) - Max. Comp./Max. Ten. - All forces 250 (lb) or less except when shown.
 TOP CHORD 2-3=-672/2008, 3-4=-592/197, 4-5=-2234/708, 5-6=-2189/807, 6-7=-2670/831,
 7-8=-2196/638, 8-10=-1056/345, 10-11=-1056/345, 11-12=-1024/299
 BOT CHORD 2-18=-1837/395, 17-18=-2105/478, 16-17=-307/653, 15-16=-550/1584, 14-15=-476/1623,
 13-14=-443/1496
 WEBS 3-18=-1358/505, 3-17=-674/2429, 4-17=-1122/405, 4-16=-407/1291, 6-16=-528/1259,
 6-15=-502/1347, 7-15=-1520/526, 8-15=-288/936, 8-14=-528/204, 8-13=-577/170,
 10-13=-368/182, 11-13=-359/1363

- NOTES-**
- Unbalanced roof live loads have been considered for this design.
 - Wind: ASCE 7-16; Vult=130mph (3-second gust) Vasd=101mph; TC DL=4.2psf; BCDL=3.0psf; h=20ft; Cat. II; Exp B; Encl., GCpi=0.18; MWFRS (envelope) gable end zone and C-C Exterior(2E) -1-6-0 to 2-6-12, Interior(1) 2-6-12 to 19-0-0, Exterior(2R) 19-0-0 to 23-0-12, Interior(1) 23-0-12 to 40-5-12 zone; end vertical right exposed; porch left exposed; C-C for members and forces & MWFRS for reactions shown; Lumber DOL=1.60 plate grip DOL=1.60
 - Building Designer / Project engineer responsible for verifying applied roof live load shown covers rain loading requirements specific to the use of this truss component.
 - Provide adequate drainage to prevent water ponding.
 - This truss has been designed for a 10.0 psf bottom chord live load nonconcurrent with any other live loads.
 - * This truss has been designed for a live load of 20.0psf on the bottom chord in all areas where a rectangle 3-6-0 tall by 2-0-0 wide will fit between the bottom chord and any other members.
 - Provide mechanical connection (by others) of truss to bearing plate capable of withstanding 100 lb uplift at joint(s) except (jt=lb) 12=270, 2=418, 18=446.

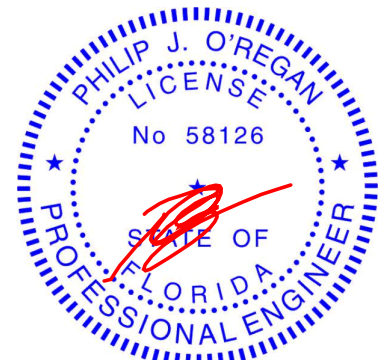

Philip J. O'Regan PE No.58126
 MiTek USA, Inc. FL Cert 6634
 6904 Parke East Blvd. Tampa FL 33610
 Date: September 7, 2021

WARNING - Verify design parameters and READ NOTES ON THIS AND INCLUDED MITEK REFERENCE PAGE MII-7473 rev. 5/19/2020 BEFORE USE.

Design valid for use only with MiTek® connectors. This design is based only upon parameters shown, and is for an individual building component, not a truss system. Before use, the building designer must verify the applicability of design parameters and properly incorporate this design into the overall building design. Bracing indicated is to prevent buckling of individual truss web and/or chord members only. Additional temporary and permanent bracing is always required for stability and to prevent collapse with possible personal injury and property damage. For general guidance regarding the fabrication, storage, delivery, erection and bracing of trusses and truss systems, see

ANSI/TPI1 Quality Criteria, DSB-89 and BCSI Building Component

Safety Information available from Truss Plate Institute, 2670 Crain Highway, Suite 203 Waldorf, MD 20601



6904 Parke East Blvd.
 Tampa, FL 33610

Job	Truss	Truss Type	Qty	Ply	IC CONST. - LIBERTY RES.	T25256450
2918935	T28	Roof Special Girder	1	1		

Job Reference (optional)

Builders FirstSource (Lake City, FL), Lake City, FL - 32055,

8.430 s Aug 16 2021 MiTek Industries, Inc. Sat Sep 4 11:24:09 2021 Page 1

ID:b2ldsklJGjOxOjHDJpp?LTyh2aU-KYR8Wf98jseVrN1wt83oiVklL6CkiSR0PWiPjyh11K

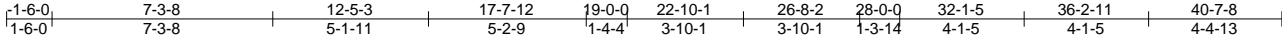

Scale = 1:76.1

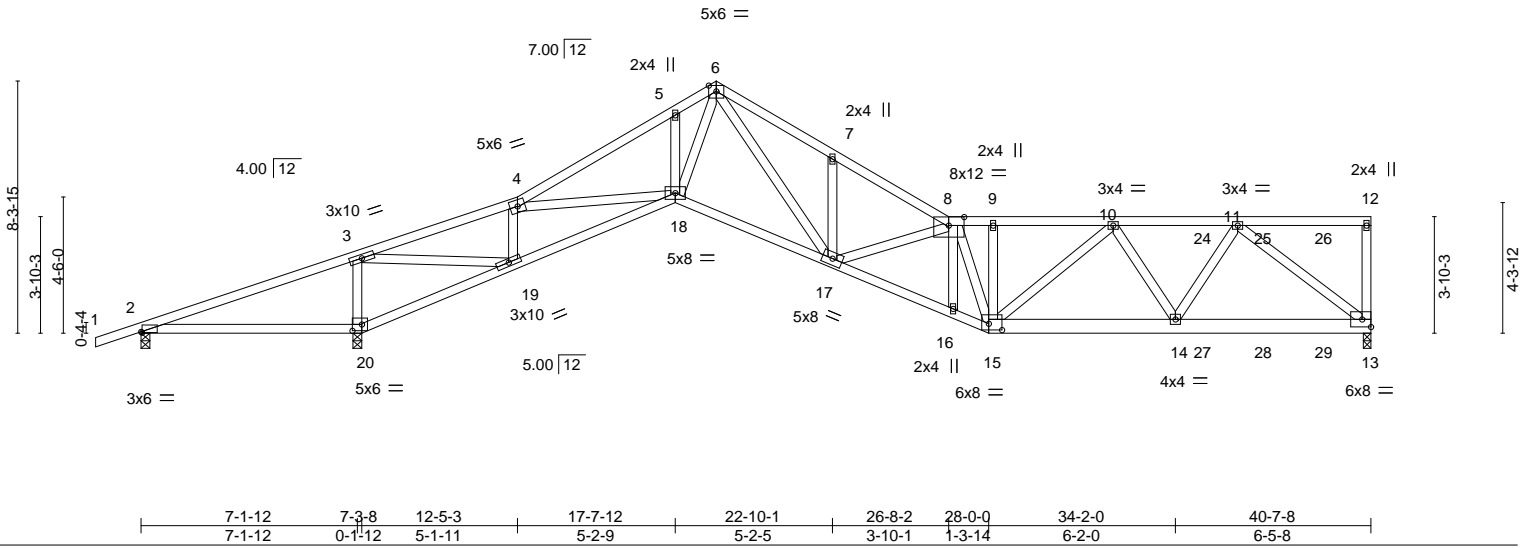

Plate Offsets (X,Y)--	[2:0-7,0-0-5], [8:0-6-2,0-3-6], [15:0-5-4,0-2-8], [20:0-3-12,0-2-8]
-----------------------	---

LOADING (psf)	SPACING-	CSI.	DEFL.	PLATES	GRIP
TCLL 20.0	Plate Grip DOL 1.25	TC 0.53	in (loc) l/defl L/d	MT20	244/190
TCDL 7.0	Lumber DOL 1.25	BC 0.74	Vert(LL) -0.22 16-17 >999 240		
BCLL 0.0 *	Rep Stress Incr NO	WB 0.92	Vert(CT) -0.40 16-17 >990 180		
BCDL 10.0	Code FBC2020/TP12014	Matrix-MS	Horz(CT) 0.15 13 n/a n/a		
				Weight: 237 lb	FT = 20%

LUMBER-	BRACING-
TOP CHORD 2x4 SP No.2 *Except* 1-4: 2x4 SP M 31	TOP CHORD Structural wood sheathing directly applied or 3-5-14 oc purlins, except end verticals.
BOT CHORD 2x4 SP No.2 *Except* 13-15: 2x6 SP No.2	BOT CHORD Rigid ceiling directly applied or 3-4-15 oc bracing.
WEBS 2x4 SP No.3	

REACTIONS. (size) 13=0-3-0, 2=0-3-8, 20=0-3-8
 Max Horz 2=241(LC 5)
 Max Uplift 13=-480(LC 9), 2=-484(LC 40), 20=-526(LC 8)
 Max Grav 13=1064(LC 1), 2=149(LC 9), 20=2402(LC 1)

FORCES. (lb) - Max. Comp./Max. Ten. - All forces 250 (lb) or less except when shown.
 TOP CHORD 2-3=-530/2205, 3-4=-454/114, 4-5=-2100/467, 5-6=-2070/507, 6-7=-2408/719,
 7-8=-2381/619, 8-9=-2137/601, 9-10=-2144/604, 10-11=-1510/536
 BOT CHORD 2-20=-2022/475, 19-20=-2304/540, 18-19=-144/483, 17-18=-299/1493, 16-17=-809/2771,
 15-16=-804/2735, 14-15=-643/1811, 13-14=-475/1120
 WEBS 3-20=-1369/383, 3-19=-467/2422, 4-19=-1112/271, 4-18=-335/1368, 5-18=-254/187,
 6-18=-278/1154, 6-17=-487/1239, 8-17=-554/219, 8-15=-1146/285, 10-15=-170/497,
 10-14=-613/239, 11-14=-200/766, 11-13=-1425/569

- NOTES-**
- Unbalanced roof live loads have been considered for this design.
 - Wind: ASCE 7-16; Vult=130mph (3-second gust) Vasd=101mph; TCDL=4.2psf; BCDL=3.0psf; h=20ft; Cat. II; Exp B; Encl., GCpi=0.18; MWFRS (envelope) gable end zone; end vertical right exposed; porch left exposed; Lumber DOL=1.60 plate grip DOL=1.60
 - Building Designer / Project engineer responsible for verifying applied roof live load shown covers rain loading requirements specific to the use of this truss component.
 - Provide adequate drainage to prevent water ponding.
 - This truss has been designed for a 10.0 psf bottom chord live load nonconcurrent with any other live loads.
 - * This truss has been designed for a live load of 20.0psf on the bottom chord in all areas where a rectangle 3-6-0 tall by 2-0-0 wide will fit between the bottom chord and any other members.
 - Provide mechanical connection (by others) of truss to bearing plate capable of withstanding 100 lb uplift at joint(s) except (jt=lb) 13=480, 2=484, 20=526.
 - Hanger(s) or other connection device(s) shall be provided sufficient to support concentrated load(s) 78 lb down and 80 lb up at 34-11-4, and 78 lb down and 80 lb up at 36-11-4, and 78 lb down and 80 lb up at 38-11-4 on top chord, and 49 lb down and 52 lb up at 34-11-4, and 49 lb down and 52 lb up at 36-11-4, and 49 lb down and 52 lb up at 38-11-4 on bottom chord. The design/selection of such connection device(s) is the responsibility of others.
 - In the LOAD CASE(S) section, loads applied to the face of the truss are noted as front (F) or back (B).

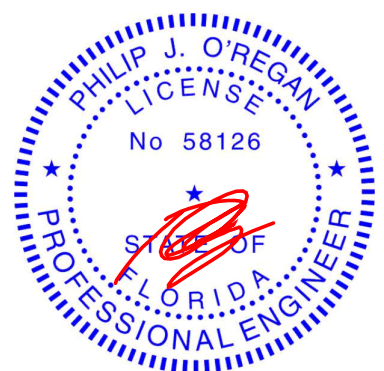

Philip J. O'Regan PE No.58126
 MiTek USA, Inc. FL Cert 6634
 6904 Parke East Blvd. Tampa FL 33610
 Date:

September 7, 2021

Continued on page 2

WARNING - Verify design parameters and READ NOTES ON THIS AND INCLUDED MITEK REFERENCE PAGE MII-7473 rev. 5/19/2020 BEFORE USE.
 Design valid for use only with MiTek® connectors. This design is based only upon parameters shown, and is for an individual building component, not a truss system. Before use, the building designer must verify the applicability of design parameters and properly incorporate this design into the overall building design. Bracing indicated is to prevent buckling of individual truss web and/or chord members only. Additional temporary and permanent bracing is always required for stability and to prevent collapse with possible personal injury and property damage. For general guidance regarding the fabrication, storage, delivery, erection and bracing of trusses and truss systems, see **ANSI/TP1 Quality Criteria, DSB-89 and BCSI Building Component Safety Information** available from Truss Plate Institute, 2670 Crain Highway, Suite 203 Waldorf, MD 20601



6904 Parke East Blvd.
 Tampa, FL 36610

Job	Truss	Truss Type	Qty	Ply	IC CONST. - LIBERTY RES.	T25256450
2918935	T28	Roof Special Girder	1	1	Job Reference (optional)	

Builders FirstSource (Lake City,FL), Lake City, FL - 32055,

8.430 s Aug 16 2021 MiTek Industries, Inc. Sat Sep 4 11:24:09 2021 Page 2
 ID:b2ldsklJGjOxOjHDJp?LTyh2aU-KYR8Wf98jseVrN1wt83oiVklL6CkiSR0PWiPjyh11K

LOAD CASE(S) Standard

- 1) Dead + Roof Live (balanced): Lumber Increase=1.25, Plate Increase=1.25
- Uniform Loads (plf)
 - Vert: 1-4=-54, 4-6=-54, 6-8=-54, 8-12=-54, 20-21=-20, 18-20=-20, 15-18=-20, 13-15=-20

WARNING - Verify design parameters and READ NOTES ON THIS AND INCLUDED MITEK REFERENCE PAGE MII-7473 rev. 5/19/2020 BEFORE USE.

Design valid for use only with MiTek® connectors. This design is based only upon parameters shown, and is for an individual building component, not a truss system. Before use, the building designer must verify the applicability of design parameters and properly incorporate this design into the overall building design. Bracing indicated is to prevent buckling of individual truss web and/or chord members only. Additional temporary and permanent bracing is always required for stability and to prevent collapse with possible personal injury and property damage. For general guidance regarding the fabrication, storage, delivery, erection and bracing of trusses and truss systems, see **ANSI/TPI1 Quality Criteria, DSB-89 and BCSI Building Component Safety Information** available from Truss Plate Institute, 2670 Crain Highway, Suite 203 Waldorf, MD 20601



6904 Parke East Blvd.
Tampa, FL 36610

Job	Truss	Truss Type	Qty	Ply	IC CONST. - LIBERTY RES.	T25256451
2918935	T29	Roof Special	5	1		

Job Reference (optional)

Builders FirstSource (Lake City, FL), Lake City, FL - 32055,

8.430 s Aug 16 2021 MiTek Industries, Inc. Sat Sep 4 11:24:11 2021 Page 1

ID:b2ldskJGjOxOjHJDJpP?LTyh2aU-GxZuxwAOHK6MI9XQ2IAXu7a3_6nFCe7kTi?oTcyh111



Scale: 3/16"=1'

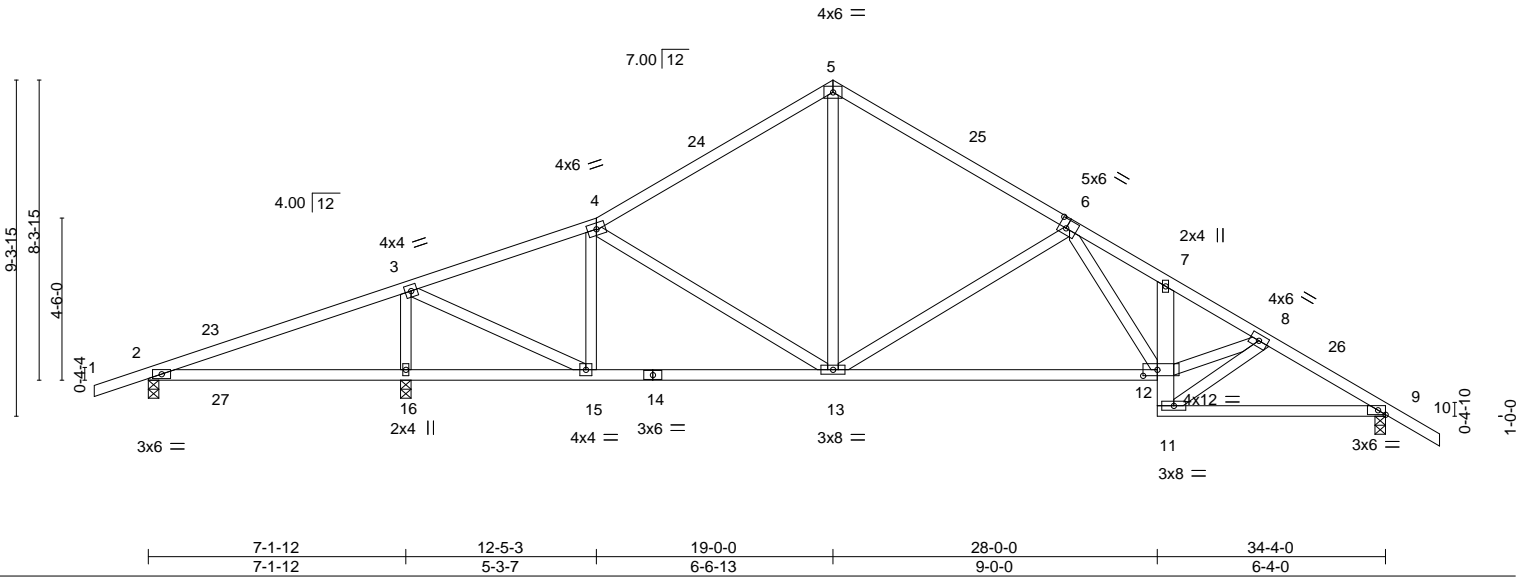

Plate Offsets (X,Y)-- [6:0-2-8,0-3-0], [9:0-2-8,Edge], [12:0-4-12,0-2-0]

LOADING (psf)	SPACING-	CSI.	DEFL.	PLATES	GRIP
TCLL 20.0	2-0-0	TC 0.59	in (loc) l/defl L/d	MT20	244/190
TCDL 7.0	Plate Grip DOL 1.25	BC 0.83	Vert(LL) 0.16 16-19 >544 240		
BCLL 0.0 *	Lumber DOL 1.25	WB 0.78	Vert(CT) -0.45 12-13 >721 180		
BCDL 10.0	Rep Stress Incr YES	Matrix-MS	Horz(CT) 0.06 9 n/a n/a		
	Code FBC2020/TP12014			Weight: 188 lb	FT = 20%

LUMBER-
TOP CHORD 2x4 SP No.2
BOT CHORD 2x4 SP No.2 *Except*
7-11: 2x6 SP No.2
WEBS 2x4 SP No.3

BRACING-
TOP CHORD Structural wood sheathing directly applied or 3-9-11 oc purlins.
BOT CHORD Rigid ceiling directly applied or 6-0-0 oc bracing.

REACTIONS. (size) 2=0-3-8, 9=0-3-8, 16=0-3-8
Max Horz 2=220(LC 11)
Max Uplift 2=-202(LC 8), 9=-250(LC 13), 16=-315(LC 12)
Max Grav 2=218(LC 23), 9=1036(LC 1), 16=1514(LC 1)

FORCES. (lb) - Max. Comp./Max. Ten. - All forces 250 (lb) or less except when shown.
TOP CHORD 2-3=-100/526, 3-4=-840/282, 4-5=-975/342, 5-6=-983/345, 6-7=-1942/522,
7-8=-1842/483, 8-9=-1593/436
BOT CHORD 2-16=-492/188, 15-16=-492/188, 13-15=-136/763, 12-13=-252/1323, 11-12=-143/743,
9-11=-307/1338
WEBS 3-16=-1333/352, 3-15=-193/1309, 4-15=-488/158, 5-13=-148/575, 6-13=-671/285,
6-12=-99/657, 8-12=-236/1281, 8-11=-1211/281

- NOTES-**
- Unbalanced roof live loads have been considered for this design.
 - Wind: ASCE 7-16; Vult=130mph (3-second gust) Vasd=101mph; TCdL=4.2psf; BCDL=3.0psf; h=20ft; Cat. II; Exp B; Encl., GCpi=0.18; MWFRS (envelope) gable end zone and C-C Exterior(2E) -1-6-0 to 1-11-3, Interior(1) 1-11-3 to 19-0-0, Exterior(2R) 19-0-0 to 22-5-3, Interior(1) 22-5-3 to 35-10-0 zone; porch left exposed; C-C for members and forces & MWFRS for reactions shown; Lumber DOL=1.60 plate grip DOL=1.60
 - Building Designer / Project engineer responsible for verifying applied roof live load shown covers rain loading requirements specific to the use of this truss component.
 - This truss has been designed for a 10.0 psf bottom chord live load nonconcurrent with any other live loads.
 - * This truss has been designed for a live load of 20.0psf on the bottom chord in all areas where a rectangle 3-6-0 tall by 2-0-0 wide will fit between the bottom chord and any other members.
 - Provide mechanical connection (by others) of truss to bearing plate capable of withstanding 100 lb uplift at joint(s) except (jt=lb) 2=202, 9=250, 16=315.

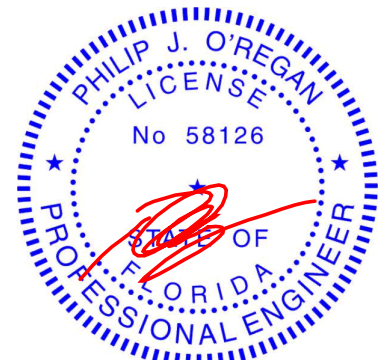

Philip J. O'Regan PE No.58126
MiTek USA, Inc. FL Cert 6634
6904 Parke East Blvd. Tampa FL 33610
Date: September 7, 2021

WARNING - Verify design parameters and READ NOTES ON THIS AND INCLUDED MITEK REFERENCE PAGE MII-7473 rev. 5/19/2020 BEFORE USE.

Design valid for use only with MiTek® connectors. This design is based only upon parameters shown, and is for an individual building component, not a truss system. Before use, the building designer must verify the applicability of design parameters and properly incorporate this design into the overall building design. Bracing indicated is to prevent buckling of individual truss web and/or chord members only. Additional temporary and permanent bracing is always required for stability and to prevent collapse with possible personal injury and property damage. For general guidance regarding the fabrication, storage, delivery, erection and bracing of trusses and truss systems, see

ANSI/TP1 Quality Criteria, DSB-89 and BCSI Building Component

Safety Information available from Truss Plate Institute, 2670 Crain Highway, Suite 203 Waldorf, MD 20601



6904 Parke East Blvd.
Tampa, FL 33610

Job	Truss	Truss Type	Qty	Ply	IC CONST. - LIBERTY RES.	T25256452
2918935	T30	Common	1	1	Job Reference (optional)	

Builders FirstSource (Lake City,FL), Lake City, FL - 32055, 8.430 s Aug 16 2021 MiTek Industries, Inc. Sat Sep 4 11:24:12 2021 Page 1
 ID:b2ldskJGjOxOjHDJPP?LTyh2aU-k77G8GB02eEDMJ6cb?hmQL7FZWAE8iMIM02yh11H

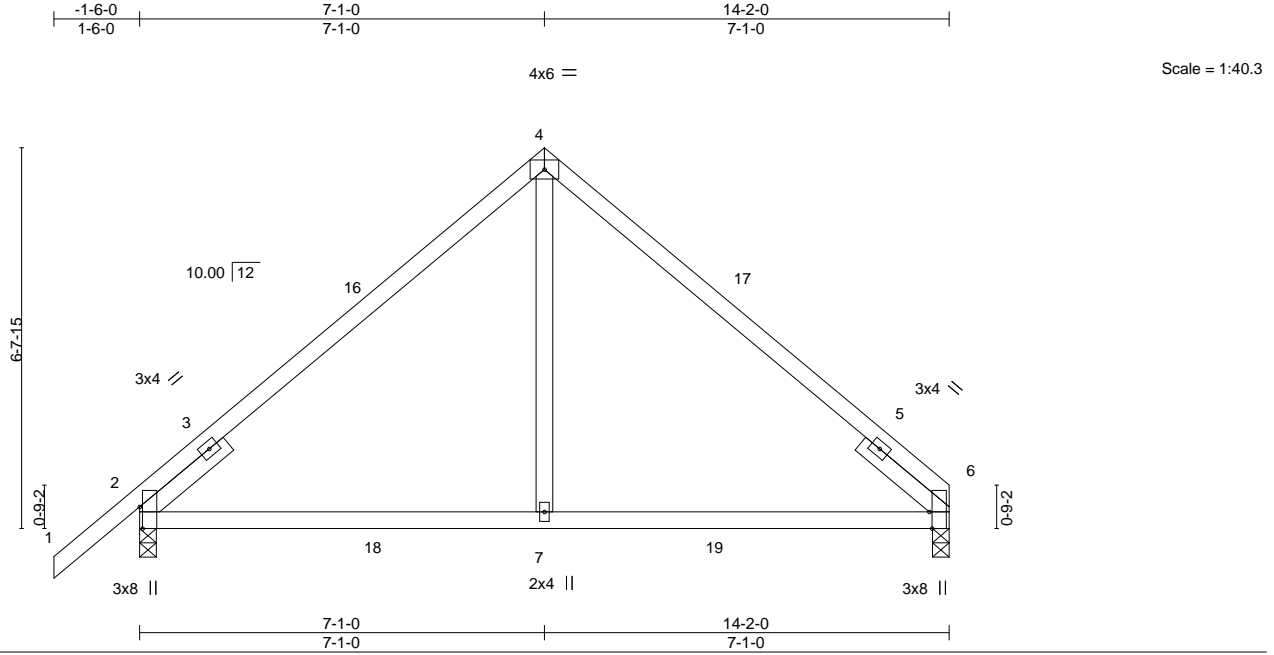

Plate Offsets (X,Y)-- [2:0-0-0,0-0-0], [2:0-4-9,Edge], [6:0-3-8,Edge]

LOADING (psf)	SPACING-	CSI.	DEFL.	PLATES	GRIP
TCLL 20.0	2-0-0	TC 0.54	in (loc) l/defl L/d	MT20	244/190
TCDL 7.0	Plate Grip DOL 1.25	BC 0.59	Vert(LL) 0.10 7-10 >999 240		
BCLL 0.0 *	Lumber DOL 1.25	WB 0.16	Vert(CT) -0.15 7-10 >999 180		
BCDL 10.0	Rep Stress Incr YES	Matrix-MS	Horz(CT) 0.03 6 n/a n/a		
	Code FBC2020/TPI2014			Weight: 67 lb	FT = 20%

LUMBER-

TOP CHORD 2x4 SP No.2
 BOT CHORD 2x4 SP No.2
 WEBS 2x4 SP No.3
 SLIDER Left 2x4 SP No.3 1-11-8, Right 2x4 SP No.3 1-11-8

BRACING-

TOP CHORD Structural wood sheathing directly applied or 6-0-0 oc purlins.
 BOT CHORD Rigid ceiling directly applied or 10-0-0 oc bracing.

REACTIONS.

(size) 6=0-3-8, 2=0-3-8
 Max Horz 2=148(LC 9)
 Max Uplift 6=-94(LC 13), 2=-128(LC 12)
 Max Grav 6=615(LC 20), 2=696(LC 19)

FORCES. (lb) - Max. Comp./Max. Ten. - All forces 250 (lb) or less except when shown.

TOP CHORD 2-4=-570/172, 4-6=-567/173
 BOT CHORD 2-7=-38/457, 6-7=-38/457
 WEBS 4-7=-24/414

NOTES-

- Unbalanced roof live loads have been considered for this design.
- Wind: ASCE 7-16; Vult=130mph (3-second gust) Vasd=101mph; TC DL=4.2psf; BCDL=3.0psf; h=20ft; Cat. II; Exp B; Encl., GCpi=0.18; MWFRS (envelope) gable end zone and C-C Exterior(2E) -1-6-0 to 1-6-0, Interior(1) 1-6-0 to 7-1-0, Exterior(2R) 7-1-0 to 10-1-0, Interior(1) 10-1-0 to 14-2-0 zone; C-C for members and forces & MWFRS for reactions shown; Lumber DOL=1.60 plate grip DOL=1.60
- Building Designer / Project engineer responsible for verifying applied roof live load shown covers rain loading requirements specific to the use of this truss component.
- This truss has been designed for a 10.0 psf bottom chord live load nonconcurrent with any other live loads.
- * This truss has been designed for a live load of 20.0psf on the bottom chord in all areas where a rectangle 3-6-0 tall by 2-0-0 wide will fit between the bottom chord and any other members, with BCDL = 10.0psf.
- Provide mechanical connection (by others) of truss to bearing plate capable of withstanding 100 lb uplift at joint(s) 6 except (jt=lb) 2=128.

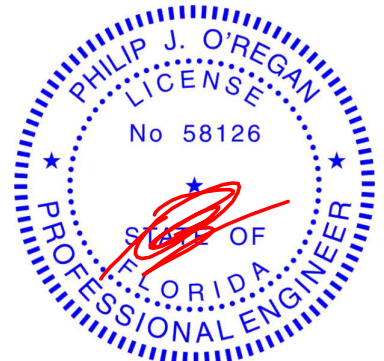

Philip J. O'Regan PE No.58126
 MiTek USA, Inc. FL Cert 6634
 6904 Parke East Blvd. Tampa FL 33610
 Date:

September 7, 2021

WARNING - Verify design parameters and READ NOTES ON THIS AND INCLUDED MITEK REFERENCE PAGE MII-7473 rev. 5/19/2020 BEFORE USE.

Design valid for use only with MiTek® connectors. This design is based only upon parameters shown, and is for an individual building component, not a truss system. Before use, the building designer must verify the applicability of design parameters and properly incorporate this design into the overall building design. Bracing indicated is to prevent buckling of individual truss web and/or chord members only. Additional temporary and permanent bracing is always required for stability and to prevent collapse with possible personal injury and property damage. For general guidance regarding the fabrication, storage, delivery, erection and bracing of trusses and truss systems, see

ANSI/TPI1 Quality Criteria, DSB-89 and BCSI Building Component

Safety Information available from Truss Plate Institute, 2670 Crain Highway, Suite 203 Waldorf, MD 20601



6904 Parke East Blvd.
 Tampa, FL 36610

Job	Truss	Truss Type	Qty	Ply	IC CONST. - LIBERTY RES.	T25256453
2918935	T30G	Common Supported Gable	1	1	Job Reference (optional)	

Builders FirstSource (Lake City,FL), Lake City, FL - 32055,

8.430 s Aug 16 2021 MiTek Industries, Inc. Sat Sep 4 11:24:13 2021 Page 1

ID:b2ldskJGjOxOjHDJPP?LTyh2aU-CJheLcCfpxM4_Tho9iC?zYfWUvfhgjq1x0UvYVyh11G



5x6 =

Scale = 1:37.9

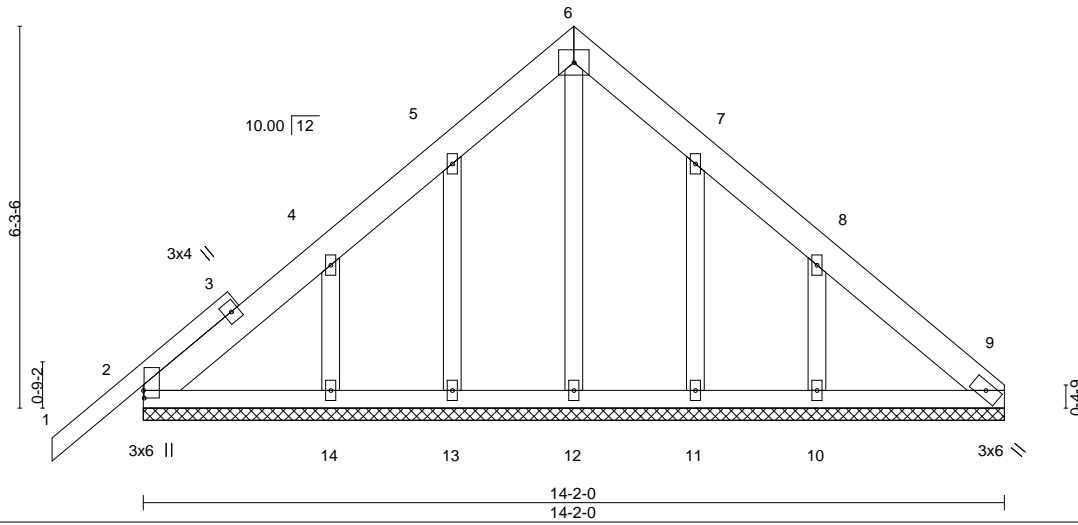

Plate Offsets (X,Y)-- [2:0-1-8,0-0-3]

LOADING (psf)	SPACING-		CSI.	DEFL.	in (loc)	l/defl	L/d	PLATES	GRIP
TCLL 20.0	Plate Grip DOL 1.25	2-0-0	TC 0.14	Vert(LL) 0.00	1	n/r	120	MT20	244/190
TCDL 7.0	Lumber DOL 1.25		BC 0.06	Vert(CT) -0.00	1	n/r	120		
BCLL 0.0 *	Rep Stress Incr YES		WB 0.07	Horz(CT) 0.00	9	n/a	n/a		
BCDL 10.0	Code FBC2020/TPI2014		Matrix-S					Weight: 96 lb	FT = 20%

LUMBER-
TOP CHORD 2x6 SP No.2 *Except*
1-3: 2x4 SP No.2
BOT CHORD 2x4 SP No.2
OTHERS 2x4 SP No.3

BRACING-
TOP CHORD Structural wood sheathing directly applied or 6-0-0 oc purlins.
BOT CHORD Rigid ceiling directly applied or 10-0-0 oc bracing.

REACTIONS. All bearings 14-2-0.
(lb) - Max Horz 2=141(LC 9)
Max Uplift All uplift 100 lb or less at joint(s) 2, 13, 11 except 14=113(LC 12), 10=138(LC 13)
Max Grav All reactions 250 lb or less at joint(s) 2, 9, 12, 13, 14, 11, 10

FORCES. (lb) - Max. Comp./Max. Ten. - All forces 250 (lb) or less except when shown.

- NOTES-**
- Unbalanced roof live loads have been considered for this design.
 - Wind: ASCE 7-16; Vult=130mph (3-second gust) Vasd=101mph; TC DL=4.2psf; BCDL=3.0psf; h=20ft; Cat. II; Exp B; Encl., GCpi=0.18; MWFRS (envelope) gable end zone and C-C Corner(3E) -1-6-0 to 1-6-0, Exterior(2N) 1-6-0 to 7-1-0, Corner(3R) 7-1-0 to 10-1-0, Exterior(2N) 10-1-0 to 14-0-4 zone; C-C for members and forces & MWFRS for reactions shown; Lumber DOL=1.60 plate grip DOL=1.60
 - Truss designed for wind loads in the plane of the truss only. For studs exposed to wind (normal to the face), see Standard Industry Gable End Details as applicable, or consult qualified building designer as per ANSI/TPI 1.
 - Building Designer / Project engineer responsible for verifying applied roof live load shown covers rain loading requirements specific to the use of this truss component.
 - All plates are 2x4 MT20 unless otherwise indicated.
 - Gable requires continuous bottom chord bearing.
 - Gable studs spaced at 2-0-0 oc.
 - This truss has been designed for a 10.0 psf bottom chord live load nonconcurrent with any other live loads.
 - * This truss has been designed for a live load of 20.0psf on the bottom chord in all areas where a rectangle 3-6-0 tall by 2-0-0 wide will fit between the bottom chord and any other members.
 - Provide mechanical connection (by others) of truss to bearing plate capable of withstanding 100 lb uplift at joint(s) 2, 13, 11 except (jt=lb) 14=113, 10=138.



Philip J. O'Regan PE No.58126
MiTek USA, Inc. FL Cert 6634
6904 Parke East Blvd. Tampa FL 33610
Date:

September 7, 2021

WARNING - Verify design parameters and READ NOTES ON THIS AND INCLUDED MITEK REFERENCE PAGE MII-7473 rev. 5/19/2020 BEFORE USE.

Design valid for use only with MiTek® connectors. This design is based only upon parameters shown, and is for an individual building component, not a truss system. Before use, the building designer must verify the applicability of design parameters and properly incorporate this design into the overall building design. Bracing indicated is to prevent buckling of individual truss web and/or chord members only. Additional temporary and permanent bracing is always required for stability and to prevent collapse with possible personal injury and property damage. For general guidance regarding the fabrication, storage, delivery, erection and bracing of trusses and truss systems, see

ANSI/TPI1 Quality Criteria, DSB-89 and BCSI Building Component

Safety Information available from Truss Plate Institute, 2670 Crain Highway, Suite 203 Waldorf, MD 20601



6904 Parke East Blvd.
Tampa, FL 36610

Job	Truss	Truss Type	Qty	Ply	IC CONST. - LIBERTY RES.	T25256454
2918935	T31	Common Girder	1	2	Job Reference (optional)	

Builders FirstSource (Lake City, FL), Lake City, FL - 32055, 8.430 s Aug 16 2021 MiTek Industries, Inc. Sat Sep 4 11:24:14 2021 Page 1
 ID: b2ldskJGjOxOjHDJPP?LTyh2aU-gVF0ZyCHaFUwccG_jQjEVmChWJyrP?7AAgET4xyh11F

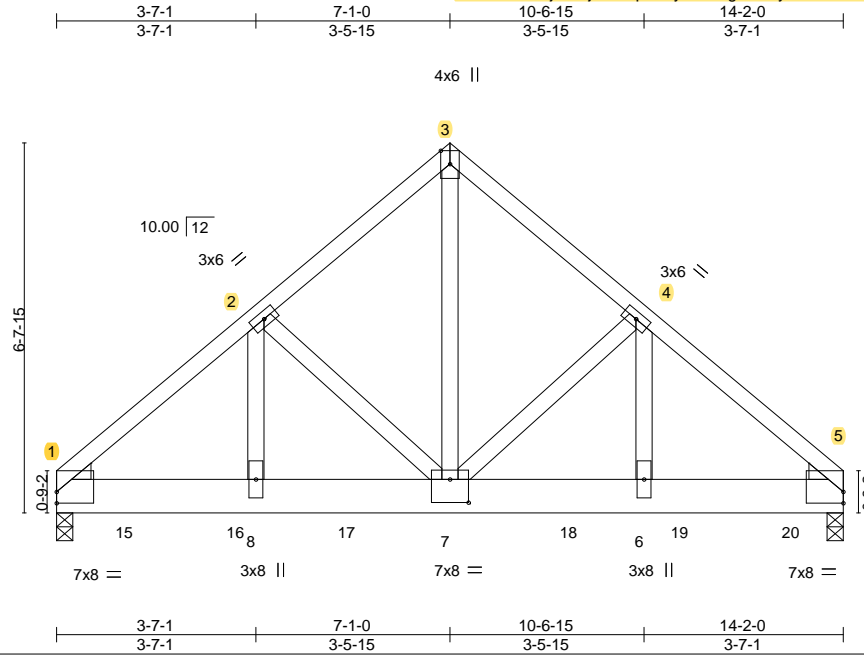

Scale = 1:41.5

Plate Offsets (X,Y)-- [1:0-0-0,0-2-7], [5:Edge,0-2-7], [7:0-4-0,0-5-0]

LOADING (psf)	SPACING-	CSI.	DEFL.	in (loc)	l/defl	L/d	PLATES	GRIP
TCLL 20.0	Plate Grip DOL 1.25	TC 0.19	Vert(LL) -0.04	7-8	>999	240	MT20	244/190
TCDL 7.0	Lumber DOL 1.25	BC 0.19	Vert(CT) -0.08	7-8	>999	180		
BCLL 0.0 *	Rep Stress Incr NO	WB 0.83	Horz(CT) 0.01	5	n/a	n/a		
BCDL 10.0	Code FBC2020/TP12014	Matrix-MS						
							Weight: 205 lb	FT = 20%

LUMBER-
 TOP CHORD 2x4 SP No.2
 BOT CHORD 2x8 SP 2400F 2.0E
 WEBS 2x4 SP No.3
 WEDGE
 Left: 2x4 SP No.3 , Right: 2x4 SP No.3

BRACING-
 TOP CHORD Structural wood sheathing directly applied or 5-7-2 oc purlins.
 BOT CHORD Rigid ceiling directly applied or 10-0-0 oc bracing.

REACTIONS. (size) 1=0-3-8, 5=0-3-8
 Max Horz 1=130(LC 5)
 Max Uplift 1=1058(LC 8), 5=1013(LC 9)
 Max Grav 1=3950(LC 1), 5=4533(LC 1)

FORCES. (lb) - Max. Comp./Max. Ten. - All forces 250 (lb) or less except when shown.
 TOP CHORD 1-2=-4990/1336, 2-3=-3621/916, 3-4=-3623/917, 4-5=-4873/1115
 BOT CHORD 1-8=-1045/3770, 7-8=-1045/3770, 6-7=-816/3687, 5-6=-816/3687
 WEBS 3-7=-1080/4360, 4-7=-1286/364, 4-6=-301/1519, 2-7=-1400/591, 2-8=-599/1683

NOTES-

- 2-ply truss to be connected together with 10d (0.131"x3") nails as follows:
 Top chords connected as follows: 2x4 - 1 row at 0-9-0 oc.
 Bottom chords connected as follows: 2x8 - 2 rows staggered at 0-7-0 oc.
 Webs connected as follows: 2x4 - 1 row at 0-9-0 oc.
- All loads are considered equally applied to all plies, except if noted as front (F) or back (B) face in the LOAD CASE(S) section. Ply to ply connections have been provided to distribute only loads noted as (F) or (B), unless otherwise indicated.
- Unbalanced roof live loads have been considered for this design.
- Wind: ASCE 7-16; Vult=130mph (3-second gust) Vasd=101mph; TCDL=4.2psf; BCDL=3.0psf; h=20ft; Cat. II; Exp B; Encl., GCp=0.18; MWFRS (envelope) gable end zone; Lumber DOL=1.60 plate grip DOL=1.60
- Building Designer / Project engineer responsible for verifying applied roof live load shown covers rain loading requirements specific to the use of this truss component.
- This truss has been designed for a 10.0 psf bottom chord live load nonconcurrent with any other live loads.
- * This truss has been designed for a live load of 20.0psf on the bottom chord in all areas where a rectangle 3-6-0 tall by 2-0-0 wide will fit between the bottom chord and any other members.
- Provide mechanical connection (by others) of truss to bearing plate capable of withstanding 100 lb uplift at joint(s) except (jt=lb) 1=1058, 5=1013.
- Hanger(s) or other connection device(s) shall be provided sufficient to support concentrated load(s) 182 lb down and 41 lb up at 1-2-12, 1697 lb down and 720 lb up at 3-2-12, 1208 lb down and 225 lb up at 5-2-12, 1209 lb down and 235 lb up at 7-2-12, 1113 lb down and 254 lb up at 9-2-12, and 1107 lb down and 251 lb up at 11-2-12, and 1110 lb down and 251 lb up at 13-2-12 on bottom chord. The design/selection of such connection device(s) is the responsibility of others.

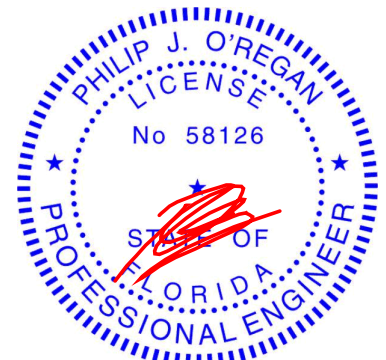

Philip J. O'Regan PE No.58126
 MiTek USA, Inc. FL Cert 6634
 6904 Parke East Blvd. Tampa FL 33610
 Date:

September 7, 2021

Continued on page 2

WARNING - Verify design parameters and READ NOTES ON THIS AND INCLUDED MITEK REFERENCE PAGE MII-7473 rev. 5/19/2020 BEFORE USE.
 Design valid for use only with MiTek® connectors. This design is based only upon parameters shown, and is for an individual building component, not a truss system. Before use, the building designer must verify the applicability of design parameters and properly incorporate this design into the overall building design. Bracing indicated is to prevent buckling of individual truss web and/or chord members only. Additional temporary and permanent bracing is always required for stability and to prevent collapse with possible personal injury and property damage. For general guidance regarding the fabrication, storage, delivery, erection and bracing of trusses and truss systems, see **ANSI/TP1 Quality Criteria, DSB-89 and BCSI Building Component Safety Information** available from Truss Plate Institute, 2670 Crain Highway, Suite 203 Waldorf, MD 20601



6904 Parke East Blvd.
 Tampa, FL 36610

Job	Truss	Truss Type	Qty	Ply	IC CONST. - LIBERTY RES.	T25256454
2918935	T31	Common Girder	1	2	Job Reference (optional)	

Builders FirstSource (Lake City,FL), Lake City, FL - 32055,

8.430 s Aug 16 2021 MiTek Industries, Inc. Sat Sep 4 11:24:14 2021 Page 2
ID:b2ldskJGjOxOjHDJPP?LTyh2aU-gVF0ZyCHaFUwccG_jQjEVmChWJyrP?7AAgET4xyh11F

LOAD CASE(S) Standard

1) Dead + Roof Live (balanced): Lumber Increase=1.25, Plate Increase=1.25

Uniform Loads (plf)

Vert: 1-3=-54, 3-5=-54, 9-12=-20

Concentrated Loads (lb)

Vert: 7=-1113(F) 15=-182(F) 16=-1697(F) 17=-1113(F) 18=-1113(F) 19=-1107(F) 20=-1110(F)

WARNING - Verify design parameters and READ NOTES ON THIS AND INCLUDED MITEK REFERENCE PAGE MII-7473 rev. 5/19/2020 BEFORE USE.

Design valid for use only with MiTek® connectors. This design is based only upon parameters shown, and is for an individual building component, not a truss system. Before use, the building designer must verify the applicability of design parameters and properly incorporate this design into the overall building design. Bracing indicated is to prevent buckling of individual truss web and/or chord members only. Additional temporary and permanent bracing is always required for stability and to prevent collapse with possible personal injury and property damage. For general guidance regarding the fabrication, storage, delivery, erection and bracing of trusses and truss systems, see **ANSI/TPI1 Quality Criteria, DSB-89 and BCSI Building Component Safety Information** available from Truss Plate Institute, 2670 Crain Highway, Suite 203 Waldorf, MD 20601



6904 Parke East Blvd.
Tampa, FL 36610

Job	Truss	Truss Type	Qty	Ply	IC CONST. - LIBERTY RES.	T25256455
2918935	T32G	GABLE	1	1	Job Reference (optional)	

Builders FirstSource (Lake City,FL), Lake City, FL - 32055,

8.430 s Aug 16 2021 MiTek Industries, Inc. Sat Sep 4 11:24:15 2021 Page 1

ID:b2lidskLjGjOxOjHDJpP?LTyh2aU-9ioPmlDvLZcnDmrBH7ET2zloQjE18bZJOKz0cNyh11E

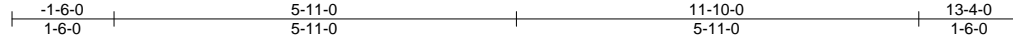

4x6 =

Scale = 1:33.9

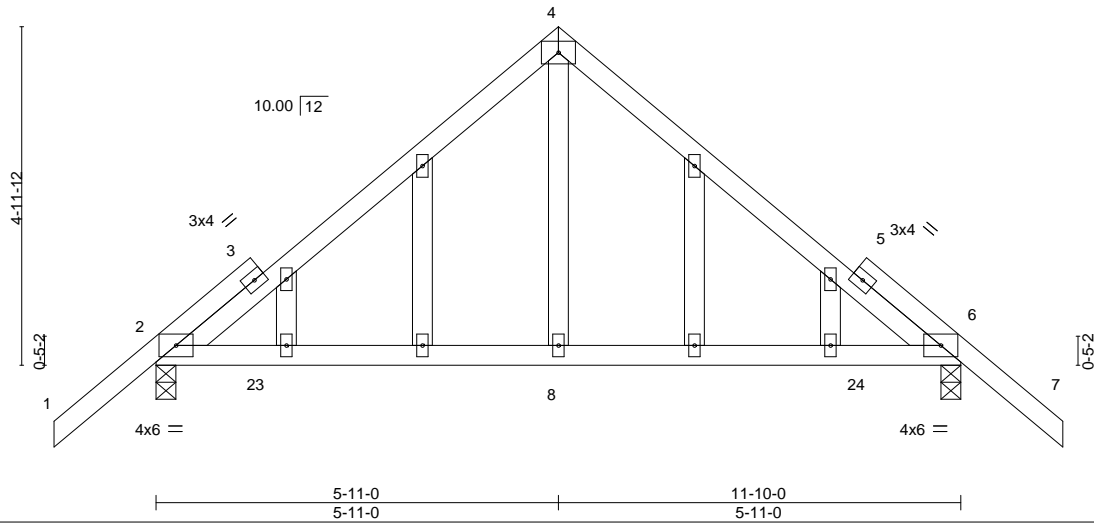

LOADING (psf)	SPACING-	CSI.	DEFL.	PLATES	GRIP
TCLL 20.0	2-0-0	TC 0.43	in (loc) l/defl L/d	MT20	244/190
TCDL 7.0	Plate Grip DOL 1.25	BC 0.39	Vert(LL) 0.09 8-22 >999 240		
BCLL 0.0 *	Lumber DOL 1.25	WB 0.18	Vert(CT) 0.08 8-22 >999 180		
BCDL 10.0	Rep Stress Incr YES	Matrix-MS	Horz(CT) -0.01 2 n/a n/a		
	Code FBC2020/TPI2014			Weight: 69 lb	FT = 20%

LUMBER-

TOP CHORD 2x4 SP No.2
 BOT CHORD 2x4 SP No.2
 WEBS 2x4 SP No.3
 OTHERS 2x4 SP No.3

BRACING-

TOP CHORD Structural wood sheathing directly applied or 6-0-0 oc purlins.
 BOT CHORD Rigid ceiling directly applied or 10-0-0 oc bracing.

REACTIONS.

(size) 2=0-3-8, 6=0-3-8
 Max Horz 2=-128(LC 10)
 Max Uplift 2=-117(LC 12), 6=-117(LC 13)
 Max Grav 2=516(LC 1), 6=516(LC 1)

FORCES. (lb) - Max. Comp./Max. Ten. - All forces 250 (lb) or less except when shown.

TOP CHORD 2-4=-449/530, 4-6=-449/530
 BOT CHORD 2-8=-250/296, 6-8=-250/296
 WEBS 4-8=-432/268

NOTES-

- Unbalanced roof live loads have been considered for this design.
- Wind: ASCE 7-16; Vult=130mph (3-second gust) Vasd=101mph; TCDL=4.2psf; BCDL=3.0psf; h=20ft; Cat. II; Exp B; Encl., GCpi=0.18; MWFRS (envelope) gable end zone and C-C Corner(3E) -1-6-0 to 1-6-0, Exterior(2N) 1-6-0 to 5-11-0, Corner(3R) 5-11-0 to 8-11-0, Exterior(2N) 8-11-0 to 13-4-0 zone; porch left and right exposed; C-C for members and forces & MWFRS for reactions shown; Lumber DOL=1.60 plate grip DOL=1.60
- Truss designed for wind loads in the plane of the truss only. For studs exposed to wind (normal to the face), see Standard Industry Gable End Details as applicable, or consult qualified building designer as per ANSI/TPI 1.
- Building Designer / Project engineer responsible for verifying applied roof live load shown covers rain loading requirements specific to the use of this truss component.
- All plates are 2x4 MT20 unless otherwise indicated.
- Gable studs spaced at 2-0-0 oc.
- This truss has been designed for a 10.0 psf bottom chord live load nonconcurrent with any other live loads.
- * This truss has been designed for a live load of 20.0psf on the bottom chord in all areas where a rectangle 3-6-0 tall by 2-0-0 wide will fit between the bottom chord and any other members.
- Provide mechanical connection (by others) of truss to bearing plate capable of withstanding 100 lb uplift at joint(s) except (jt=lb) 2=117, 6=117.

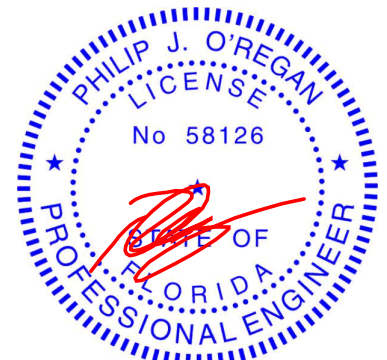

Philip J. O'Regan PE No.58126
 MiTek USA, Inc. FL Cert 6634
 6904 Parke East Blvd. Tampa FL 33610
 Date:

September 7, 2021

WARNING - Verify design parameters and READ NOTES ON THIS AND INCLUDED MITEK REFERENCE PAGE MII-7473 rev. 5/19/2020 BEFORE USE.

Design valid for use only with MiTek® connectors. This design is based only upon parameters shown, and is for an individual building component, not a truss system. Before use, the building designer must verify the applicability of design parameters and properly incorporate this design into the overall building design. Bracing indicated is to prevent buckling of individual truss web and/or chord members only. Additional temporary and permanent bracing is always required for stability and to prevent collapse with possible personal injury and property damage. For general guidance regarding the fabrication, storage, delivery, erection and bracing of trusses and truss systems, see

ANSI/TPI1 Quality Criteria, DSB-89 and BCSI Building Component

Safety Information available from Truss Plate Institute, 2670 Crain Highway, Suite 203 Waldorf, MD 20601



6904 Parke East Blvd.
 Tampa, FL 33610

Job 2918935	Truss T33	Truss Type Piggyback Base	Qty 3	Ply 1	IC CONST. - LIBERTY RES. Job Reference (optional)	T25256456
----------------	--------------	------------------------------	----------	----------	--	-----------

Builders FirstSource (Lake City,FL), Lake City, FL - 32055,

8.430 s Aug 16 2021 MiTek Industries, Inc. Sat Sep 4 11:24:16 2021 Page 1

ID:b2ldskJGjOxOjHDJPPp?LTyh2aU-duMn_eEX6skerwPNqrmibBHvg7VntxKTd_jZ9qyh11D

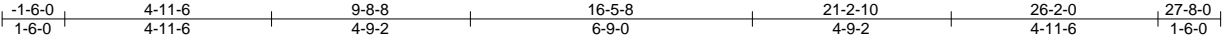

Scale = 1:55.1

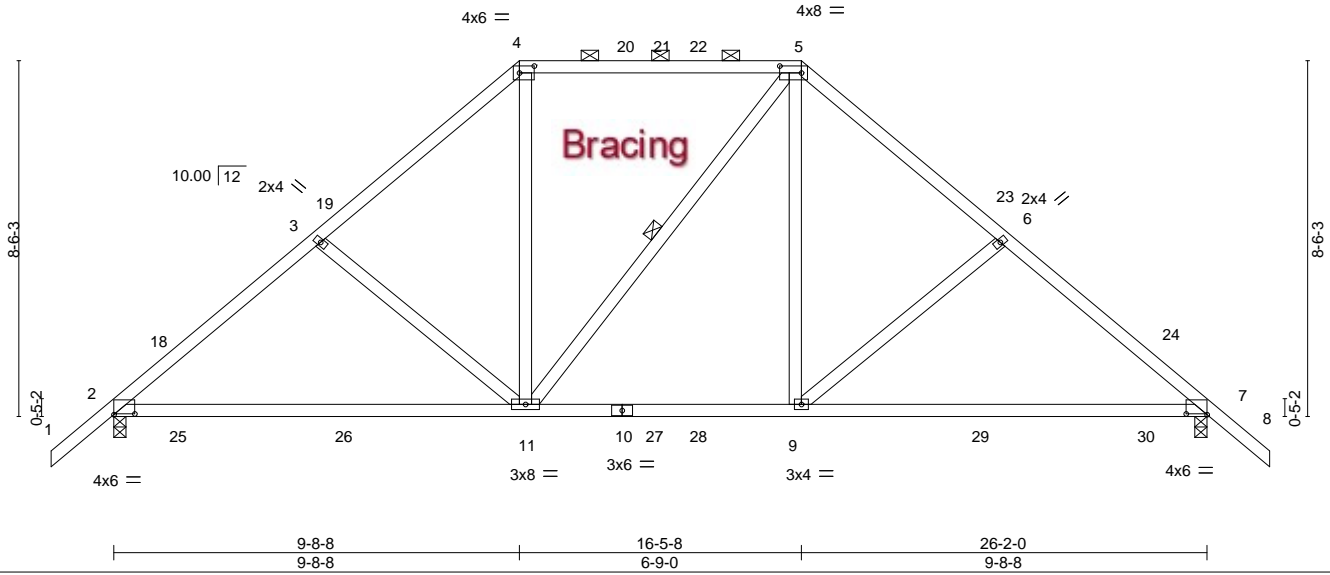

Plate Offsets (X,Y)-- [2:0-6-0,0-0-3], [4:0-4-4,0-2-0], [5:0-6-4,0-2-0], [7:0-6-0,0-0-4]

LOADING (psf)	SPACING-	CSI.	DEFL.	PLATES	GRIP
TCLL 20.0	2-0-0	TC 0.66	in (loc) l/defl L/d	MT20	244/190
TCDL 7.0	Plate Grip DOL 1.25	BC 0.77	Vert(LL) 0.33 9-17 >940 240		
BCLL 0.0 *	Lumber DOL 1.25	WB 0.59	Vert(CT) -0.43 9-17 >723 180		
BCDL 10.0	Rep Stress Incr YES	Matrix-MS	Horz(CT) 0.03 7 n/a n/a		
	Code FBC2020/TPI2014			Weight: 150 lb	FT = 20%

LUMBER-

TOP CHORD 2x4 SP No.2
 BOT CHORD 2x4 SP No.2
 WEBS 2x4 SP No.3

BRACING-

TOP CHORD Structural wood sheathing directly applied or 4-6-3 oc purlins, except 2-0-0 oc purlins (5-1-5 max.): 4-5.
 BOT CHORD Rigid ceiling directly applied or 6-3-10 oc bracing.
 WEBS 1 Row at midpt 5-11

REACTIONS.

(size) 2=0-3-8, 7=0-3-8
 Max Horz 2=-207(LC 10)
 Max Uplift 2=-273(LC 9), 7=-273(LC 8)
 Max Grav 2=1122(LC 2), 7=1128(LC 2)

FORCES. (lb) - Max. Comp./Max. Ten. - All forces 250 (lb) or less except when shown.

TOP CHORD 2-3=-1301/855, 3-4=-1146/843, 4-5=-828/700, 5-6=-1156/843, 6-7=-1311/854
 BOT CHORD 2-11=-607/986, 9-11=-460/835, 7-9=-610/993
 WEBS 3-11=-273/203, 4-11=-427/443, 5-9=-455/460, 6-9=-273/204

NOTES-

- Unbalanced roof live loads have been considered for this design.
- Wind: ASCE 7-16; Vult=130mph (3-second gust) Vasd=101mph; TCCL=4.2psf; BCDL=3.0psf; h=20ft; Cat. II; Exp B; Encl., GCpi=0.18; MWFRS (envelope) gable end zone and C-C Exterior(2E) -1-6-0 to 1-6-0, Interior(1) 1-6-0 to 9-8-8, Exterior(2R) 9-8-8 to 13-11-7, Interior(1) 13-11-7 to 16-5-8, Exterior(2R) 16-5-8 to 20-8-7, Interior(1) 20-8-7 to 27-8-0 zone; porch left and right exposed; C-C for members and forces & MWFRS for reactions shown; Lumber DOL=1.60 plate grip DOL=1.60
- Building Designer / Project engineer responsible for verifying applied roof live load shown covers rain loading requirements specific to the use of this truss component.
- Provide adequate drainage to prevent water ponding.
- This truss has been designed for a 10.0 psf bottom chord live load nonconcurrent with any other live loads.
- * This truss has been designed for a live load of 20.0psf on the bottom chord in all areas where a rectangle 3-6-0 tall by 2-0-0 wide will fit between the bottom chord and any other members, with BCDL = 10.0psf.
- Provide mechanical connection (by others) of truss to bearing plate capable of withstanding 100 lb uplift at joint(s) except (jt=lb) 2=273, 7=273.
- Graphical purlin representation does not depict the size or the orientation of the purlin along the top and/or bottom chord.

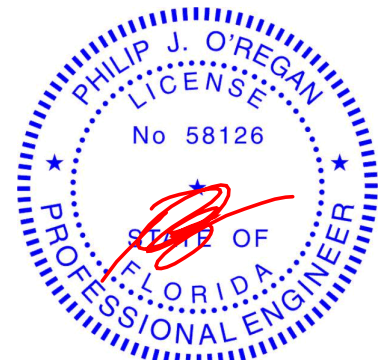

Philip J. O'Regan PE No.58126
 MiTek USA, Inc. FL Cert 6634
 6904 Parke East Blvd. Tampa FL 33610
 Date:

September 7, 2021

WARNING - Verify design parameters and READ NOTES ON THIS AND INCLUDED MITEK REFERENCE PAGE MII-7473 rev. 5/19/2020 BEFORE USE.

Design valid for use only with MiTek® connectors. This design is based only upon parameters shown, and is for an individual building component, not a truss system. Before use, the building designer must verify the applicability of design parameters and properly incorporate this design into the overall building design. Bracing indicated is to prevent buckling of individual truss web and/or chord members only. Additional temporary and permanent bracing is always required for stability and to prevent collapse with possible personal injury and property damage. For general guidance regarding the fabrication, storage, delivery, erection and bracing of trusses and truss systems, see

ANSI/TPI1 Quality Criteria, DSB-89 and BCSI Building Component

Safety Information available from Truss Plate Institute, 2670 Crain Highway, Suite 203 Waldorf, MD 20601



6904 Parke East Blvd.
 Tampa, FL 33610

Job	Truss	Truss Type	Qty	Ply	IC CONST. - LIBERTY RES.	T25256457
2918935	T33G	GABLE II	1	1		

Builders FirstSource (Lake City, FL), Lake City, FL - 32055, 8.430 s Aug 16 2021 MiTek Industries, Inc. Sat Sep 4 11:24:19 2021 Page 1
 ID:b2ldskJGjOxOjHDJpp?LTyh2aU-1T2vcfGPOn6DiO8yWzJPCpvSDKZC4HavJyxEl8yh11A

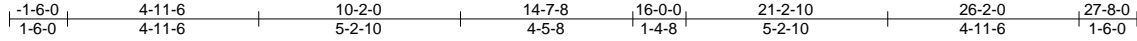

Scale = 1:59.6

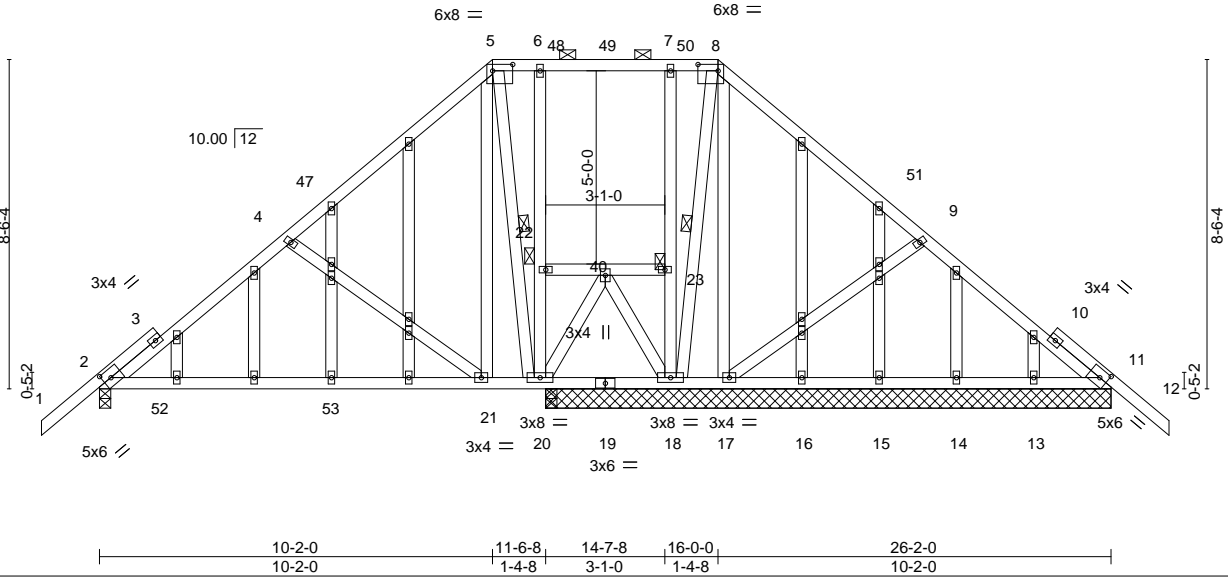

Plate Offsets (X,Y)-- [2:0-2-8,0-2-8], [5:0-6-4,0-2-0], [8:0-6-4,0-2-0], [11:0-2-8,0-2-8]

LOADING (psf)	SPACING-	CSI.	DEFL.	PLATES	GRIP
TCLL 20.0	2-0-0	TC 0.51	in (loc) l/defl L/d	MT20	244/190
TCDL 7.0	Plate Grip DOL 1.25	BC 0.63	Vert(LL) 0.25 21-43 >541 240		
BCLL 0.0 *	Lumber DOL 1.25	WB 0.69	Vert(CT) -0.33 21-43 >414 180		
BCDL 10.0	Rep Stress Incr YES	Matrix-MS	Horz(CT) 0.01 2 n/a n/a		
	Code FBC2020/TPI2014			Weight: 243 lb	FT = 20%

LUMBER-	BRACING-
TOP CHORD 2x4 SP No.2	TOP CHORD Structural wood sheathing directly applied or 6-0-0 oc purlins, except 2-0-0 oc purlins (10-0-0 max.): 5-8.
BOT CHORD 2x4 SP No.2	BOT CHORD Rigid ceiling directly applied or 6-0-0 oc bracing, Except: 10-0-0 oc bracing: 2-21.
WEBS 2x4 SP No.3	WEBS 1 Row at midpt 5-20, 8-18
OTHERS 2x4 SP No.3	JOINTS 1 Brace at Jt(s): 22, 23

REACTIONS. All bearings 14-7-8 except (jt=length) 2=0-3-8.
 (lb) - Max Horz 2=207(LC 11)
 Max Uplift All uplift 100 lb or less at joint(s) 2, 11, 18, 13 except 17=171(LC 13), 20=241(LC 9)
 Max Grav All reactions 250 lb or less at joint(s) 13, 14, 15, 16, 11 except 2=438(LC 23), 11=267(LC 24), 17=305(LC 20), 20=647(LC 1), 20=647(LC 1), 18=285(LC 1)

FORCES. (lb) - Max. Comp./Max. Ten. - All forces 250 (lb) or less except when shown.
 TOP CHORD 2-4=289/136
 WEBS 4-21=280/232, 5-21=557/492, 9-17=257/214, 5-20=546/561

- NOTES-**
- Unbalanced roof live loads have been considered for this design.
 - Wind: ASCE 7-16; Vult=130mph (3-second gust) Vasd=101mph; TCCL=4.2psf; BCDL=3.0psf; h=20ft; Cat. II; Exp B; Encl., GCpi=0.18; MWFRS (envelope) gable end zone and C-C Exterior(2E) -1-6-0 to 1-6-0, Interior(1) 1-6-0 to 10-2-0, Exterior(2R) 10-2-0 to 14-4-15, Interior(1) 14-4-15 to 16-0-0, Exterior(2R) 16-0-0 to 20-2-15, Interior(1) 20-2-15 to 27-8-0 zone; porch left and right exposed; C-C for members and forces & MWFRS for reactions shown; Lumber DOL=1.60 plate grip DOL=1.60
 - Truss designed for wind loads in the plane of the truss only. For studs exposed to wind (normal to the face), see Standard Industry Gable End Details as applicable, or consult qualified building designer as per ANSI/TPI 1.
 - Building Designer / Project engineer responsible for verifying applied roof live load shown covers rain loading requirements specific to the use of this truss component.
 - Provide adequate drainage to prevent water ponding.
 - All plates are 2x4 MT20 unless otherwise indicated.
 - Gable studs spaced at 2-0-0 oc.
 - This truss has been designed for a 10.0 psf bottom chord live load nonconcurrent with any other live loads.
 - * This truss has been designed for a live load of 20.0psf on the bottom chord in all areas where a rectangle 3-6-0 tall by 2-0-0 wide will fit between the bottom chord and any other members.
 - Provide mechanical connection (by others) of truss to bearing plate capable of withstanding 100 lb uplift at joint(s) 2, 11, 18, 13, 11 except (jt=lb) 17=171, 20=241.
 - Graphical purlin representation does not depict the size or the orientation of the purlin along the top and/or bottom chord.

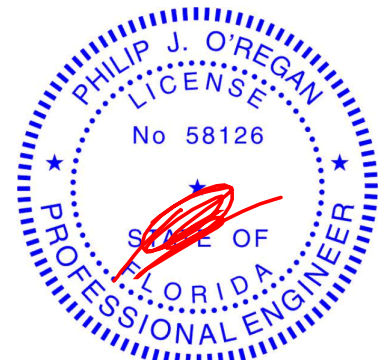

Philip J. O'Regan PE No.58126
 MiTek USA, Inc. FL Cert 6634
 6904 Parke East Blvd. Tampa FL 33610
 Date: September 7, 2021

WARNING - Verify design parameters and READ NOTES ON THIS AND INCLUDED MITEK REFERENCE PAGE MII-7473 rev. 5/19/2020 BEFORE USE.
 Design valid for use only with MiTek® connectors. This design is based only upon parameters shown, and is for an individual building component, not a truss system. Before use, the building designer must verify the applicability of design parameters and properly incorporate this design into the overall building design. Bracing indicated is to prevent buckling of individual truss web and/or chord members only. Additional temporary and permanent bracing is always required for stability and to prevent collapse with possible personal injury and property damage. For general guidance regarding the fabrication, storage, delivery, erection and bracing of trusses and truss systems, see ANSITPI1 Quality Criteria, DSB-89 and BCSI Building Component Safety Information available from Truss Plate Institute, 2670 Crain Highway, Suite 203 Waldorf, MD 20601



Job	Truss	Truss Type	Qty	Ply	IC CONST. - LIBERTY RES.	T25256458
2918935	T34	Piggyback Base	1	1	Job Reference (optional)	

Builders FirstSource (Lake City,FL), Lake City, FL - 32055, 8.430 s Aug 16 2021 MiTek Industries, Inc. Sat Sep 4 11:24:20 2021 Page 1
 ID:b2ldsklJGjOxOjHDJpp?LTyh2aU-Vfclp?H295F4KXj83gqel1SdktGpfc2Ychnlbyh119

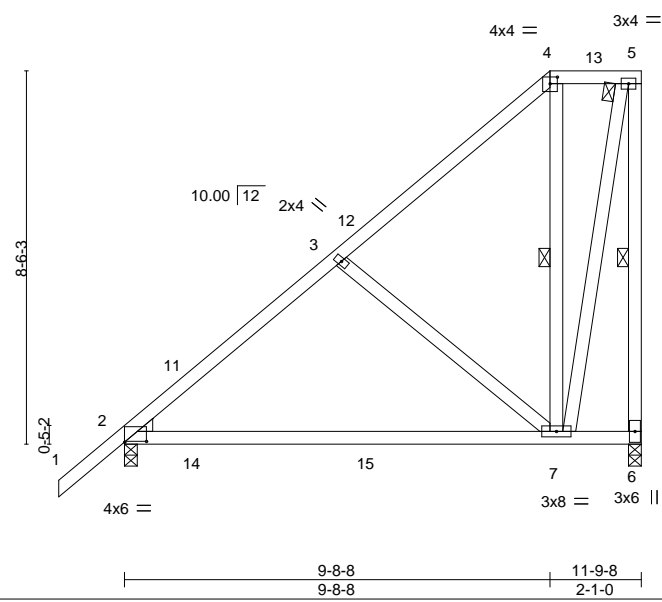
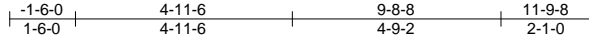

Bracing

Scale = 1:52.6

Plate Offsets (X,Y)-- [2:0-6-0,0-0-3], [4:0-2-0,0-1-13]

LOADING (psf)	SPACING-	CSI.	DEFL.	in (loc)	l/defl	L/d	PLATES	GRIP
TCLL 20.0	Plate Grip DOL 1.25	TC 0.49	Vert(LL) 0.37	7-10	>381	240	MT20	244/190
TCDL 7.0	Lumber DOL 1.25	BC 0.70	Vert(CT) -0.38	7-10	>371	180		
BCLL 0.0 *	Rep Stress Incr YES	WB 0.98	Horz(CT) -0.01	2	n/a	n/a		
BCDL 10.0	Code FBC2020/TPI2014	Matrix-MS						
							Weight: 88 lb	FT = 20%

LUMBER-

TOP CHORD 2x4 SP No.2
 BOT CHORD 2x4 SP No.2
 WEBS 2x4 SP No.3
 WEDGE
 Left: 2x4 SP No.3

BRACING-

TOP CHORD Structural wood sheathing directly applied or 6-0-0 oc purlins, except end verticals, and 2-0-0 oc purlins (6-0-0 max.): 4-5.
 BOT CHORD Rigid ceiling directly applied or 6-0-0 oc bracing.
 WEBS 1 Row at midpt 5-6, 4-7

REACTIONS.

(size) 6=0-3-8, 2=0-3-8
 Max Horz 2=317(LC 12)
 Max Uplift 6=207(LC 9), 2=82(LC 9)
 Max Grav 6=426(LC 1), 2=517(LC 1)

FORCES.

(lb) - Max. Comp./Max. Ten. - All forces 250 (lb) or less except when shown.
 TOP CHORD 2-3=-421/159, 5-6=-492/731
 BOT CHORD 2-7=-387/297
 WEBS 3-7=-261/297, 5-7=-739/467

NOTES-

- Unbalanced roof live loads have been considered for this design.
- Wind: ASCE 7-16; Vult=130mph (3-second gust) Vasd=101mph; TC DL=4.2psf; BCDL=3.0psf; h=20ft; Cat. II; Exp B; Encl., GCpi=0.18; MWFRS (envelope) gable end zone and C-C Exterior(2E) -1-6-0 to 1-6-0, Interior(1) 1-6-0 to 9-8-8, Exterior(2E) 9-8-8 to 11-7-12 zone; porch left and right exposed; C-C for members and forces & MWFRS for reactions shown; Lumber DOL=1.60 plate grip DOL=1.60
- Building Designer / Project engineer responsible for verifying applied roof live load shown covers rain loading requirements specific to the use of this truss component.
- Provide adequate drainage to prevent water ponding.
- This truss has been designed for a 10.0 psf bottom chord live load nonconcurrent with any other live loads.
- * This truss has been designed for a live load of 20.0psf on the bottom chord in all areas where a rectangle 3-6-0 tall by 2-0-0 wide will fit between the bottom chord and any other members.
- Provide mechanical connection (by others) of truss to bearing plate capable of withstanding 100 lb uplift at joint(s) 2 except (jt=lb) 6=207.
- Graphical purlin representation does not depict the size or the orientation of the purlin along the top and/or bottom chord.

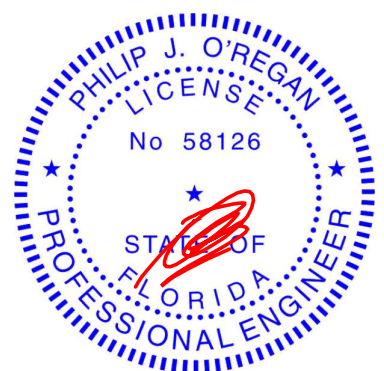

Philip J. O'Regan PE No.58126
 MiTek USA, Inc. FL Cert 6634
 6904 Parke East Blvd. Tampa FL 33610
 Date: September 7, 2021

Job	Truss	Truss Type	Qty	Ply	IC CONST. - LIBERTY RES.	T25256459
2918935	TG01	Flat Girder	1	1	Job Reference (optional)	

Builders FirstSource (Lake City,FL), Lake City, FL - 32055,

8.430 s Aug 16 2021 MiTek Industries, Inc. Sat Sep 4 11:24:20 2021 Page 1
ID:b2ldskJGjOxOjHDJPP?LTyh2aU-Vfclp?H295F4KXj83gqel1Sgrkw4pua2Ychnlbyh119

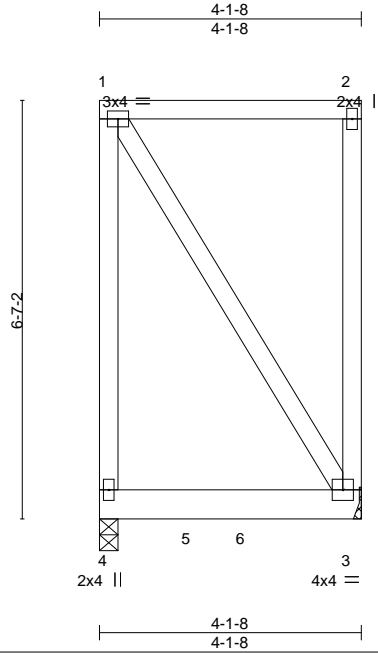

Scale = 1:36.3

LOADING (psf)	SPACING-	CSI.	DEFL.	in (loc)	l/defl	L/d	PLATES	GRIP
TCLL 20.0	2-0-0 Plate Grip DOL 1.25	TC 0.26	Vert(LL) 0.03	3-4	>999	240	MT20	244/190
TCDL 7.0	Lumber DOL 1.25	BC 0.52	Vert(CT) -0.04	3-4	>999	180		
BCLL 0.0 *	Rep Stress Incr NO	WB 0.00	Horz(CT) -0.00	3	n/a	n/a		
BCDL 10.0	Code FBC2020/TPI2014	Matrix-MP					Weight: 43 lb	FT = 20%

LUMBER-

TOP CHORD 2x4 SP No.2
BOT CHORD 2x6 SP No.2
WEBS 2x4 SP No.3

BRACING-

TOP CHORD Structural wood sheathing directly applied or 4-1-8 oc purlins, except end verticals.
BOT CHORD Rigid ceiling directly applied or 10-0-0 oc bracing.

REACTIONS.

(size) 4=0-3-8, 3=Mechanical
Max Uplift 4=-218(LC 4), 3=-187(LC 4)
Max Grav 4=425(LC 2), 3=374(LC 2)

FORCES. (lb) - Max. Comp./Max. Ten. - All forces 250 (lb) or less except when shown.

NOTES-

- 1) Wind: ASCE 7-16; Vult=130mph (3-second gust) Vasd=101mph; TCDL=4.2psf; BCDL=3.0psf; h=20ft; Cat. II; Exp B; Encl., GCpi=0.18; MWFRS (envelope) gable end zone; Lumber DOL=1.60 plate grip DOL=1.60
- 2) Building Designer / Project engineer responsible for verifying applied roof live load shown covers rain loading requirements specific to the use of this truss component.
- 3) Provide adequate drainage to prevent water ponding.
- 4) This truss has been designed for a 10.0 psf bottom chord live load nonconcurrent with any other live loads.
- 5) * This truss has been designed for a live load of 20.0psf on the bottom chord in all areas where a rectangle 3-6-0 tall by 2-0-0 wide will fit between the bottom chord and any other members.
- 6) Refer to girder(s) for truss to truss connections.
- 7) Provide mechanical connection (by others) of truss to bearing plate capable of withstanding 100 lb uplift at joint(s) except (it=lb) 4=218, 3=187.
- 8) Hanger(s) or other connection device(s) shall be provided sufficient to support concentrated load(s) 290 lb down and 178 lb up at 1-5-8, and 290 lb down and 178 lb up at 2-3-12 on bottom chord. The design/selection of such connection device(s) is the responsibility of others.
- 9) In the LOAD CASE(S) section, loads applied to the face of the truss are noted as front (F) or back (B).

LOAD CASE(S) Standard

- 1) Dead + Roof Live (balanced): Lumber Increase=1.25, Plate Increase=1.25
Uniform Loads (plf)
Vert: 1-2=-54, 3-4=-20
Concentrated Loads (lb)
Vert: 5=-225(B) 6=-225(B)

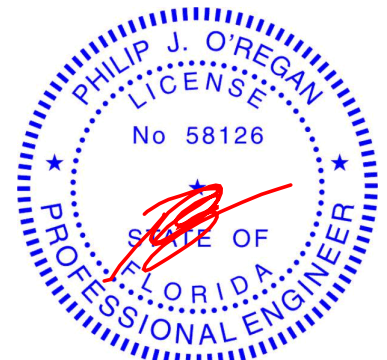

Philip J. O'Regan PE No.58126
MiTek USA, Inc. FL Cert 6634
6904 Parke East Blvd. Tampa FL 33610
Date:

September 7, 2021

WARNING - Verify design parameters and READ NOTES ON THIS AND INCLUDED MITEK REFERENCE PAGE MII-7473 rev. 5/19/2020 BEFORE USE.

Design valid for use only with MiTek® connectors. This design is based only upon parameters shown, and is for an individual building component, not a truss system. Before use, the building designer must verify the applicability of design parameters and properly incorporate this design into the overall building design. Bracing indicated is to prevent buckling of individual truss web and/or chord members only. Additional temporary and permanent bracing is always required for stability and to prevent collapse with possible personal injury and property damage. For general guidance regarding the fabrication, storage, delivery, erection and bracing of trusses and truss systems, see

Safety Information available from Truss Plate Institute, 2670 Crain Highway, Suite 203 Waldorf, MD 20601

ANSI/TPI1 Quality Criteria, DSB-89 and BCSI Building Component



6904 Parke East Blvd.
Tampa, FL 36610

Job	Truss	Truss Type	Qty	Ply	IC CONST. - LIBERTY RES.	T25256460
2918935	TG02	Flat Girder	1	1	Job Reference (optional)	

Builders FirstSource (Lake City,FL), Lake City, FL - 32055,

8.430 s Aug 16 2021 MiTek Industries, Inc. Sat Sep 4 11:24:21 2021 Page 1

ID:b2ldskJGjOxOjHDJpp?LTyh2aU-zsAg1LlgwPNxxhlLdOLIE_rb8HPYLqCnGQKq1yh118

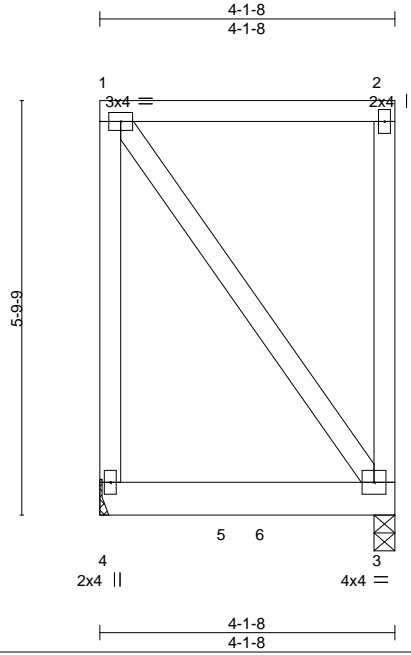

Scale: 3/8"=1'

LOADING (psf)	SPACING-	CSI.	DEFL.	in (loc)	I/defl	L/d	PLATES	GRIP
TCLL 20.0	2-0-0 Plate Grip DOL 1.25	TC 0.26	Vert(LL) 0.02	3-4	>999	240	MT20	244/190
TCDL 7.0	Lumber DOL 1.25	BC 0.39	Vert(CT) -0.03	3-4	>999	180		
BCLL 0.0 *	Rep Stress Incr NO	WB 0.00	Horz(CT) -0.00	3	n/a	n/a		
BCDL 10.0	Code FBC2020/TPI2014	Matrix-MP					Weight: 40 lb	FT = 20%

LUMBER-

TOP CHORD 2x4 SP No.2
 BOT CHORD 2x6 SP No.2
 WEBS 2x4 SP No.3

BRACING-

TOP CHORD Structural wood sheathing directly applied or 4-1-8 oc purlins, except end verticals.
 BOT CHORD Rigid ceiling directly applied or 10-0-0 oc bracing.

REACTIONS.

(size) 4=Mechanical, 3=0-3-8
 Max Uplift 4=185(LC 4), 3=187(LC 4)
 Max Grav 4=337(LC 1), 3=340(LC 1)

FORCES. (lb) - Max. Comp./Max. Ten. - All forces 250 (lb) or less except when shown.

NOTES-

- 1) Wind: ASCE 7-16; Vult=130mph (3-second gust) Vasd=101mph; TCDL=4.2psf; BCDL=3.0psf; h=20ft; Cat. II; Exp B; Encl., GCpi=0.18; MWFRS (envelope) gable end zone; Lumber DOL=1.60 plate grip DOL=1.60
- 2) Building Designer / Project engineer responsible for verifying applied roof live load shown covers rain loading requirements specific to the use of this truss component.
- 3) Provide adequate drainage to prevent water ponding.
- 4) This truss has been designed for a 10.0 psf bottom chord live load nonconcurrent with any other live loads.
- 5) * This truss has been designed for a live load of 20.0psf on the bottom chord in all areas where a rectangle 3-6-0 tall by 2-0-0 wide will fit between the bottom chord and any other members.
- 6) Refer to girder(s) for truss to truss connections.
- 7) Provide mechanical connection (by others) of truss to bearing plate capable of withstanding 100 lb uplift at joint(s) except (it=lb) 4=185, 3=187.
- 8) Hanger(s) or other connection device(s) shall be provided sufficient to support concentrated load(s) 197 lb down and 162 lb up at 1-9-10, and 197 lb down and 162 lb up at 2-4-2 on bottom chord. The design/selection of such connection device(s) is the responsibility of others.
- 9) In the LOAD CASE(S) section, loads applied to the face of the truss are noted as front (F) or back (B).

LOAD CASE(S) Standard

- 1) Dead + Roof Live (balanced): Lumber Increase=1.25, Plate Increase=1.25
 Uniform Loads (plf)
 Vert: 1-2=-54, 3-4=-20
 Concentrated Loads (lb)
 Vert: 5=-197(B) 6=-197(B)

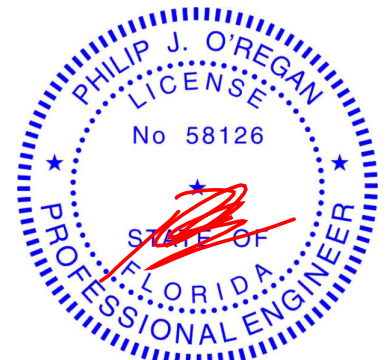

Philip J. O'Regan PE No.58126
 MiTek USA, Inc. FL Cert 6634
 6904 Parke East Blvd. Tampa FL 33610
 Date:

September 7, 2021

WARNING - Verify design parameters and READ NOTES ON THIS AND INCLUDED MITEK REFERENCE PAGE MII-7473 rev. 5/19/2020 BEFORE USE.

Design valid for use only with MiTek® connectors. This design is based only upon parameters shown, and is for an individual building component, not a truss system. Before use, the building designer must verify the applicability of design parameters and properly incorporate this design into the overall building design. Bracing indicated is to prevent buckling of individual truss web and/or chord members only. Additional temporary and permanent bracing is always required for stability and to prevent collapse with possible personal injury and property damage. For general guidance regarding the fabrication, storage, delivery, erection and bracing of trusses and truss systems, see

ANSI/TPI1 Quality Criteria, DSB-89 and BCSI Building Component

Safety Information available from Truss Plate Institute, 2670 Crain Highway, Suite 203 Waldorf, MD 20601



6904 Parke East Blvd.
 Tampa, FL 36610

Symbols

PLATE LOCATION AND ORIENTATION

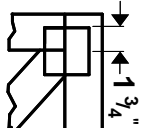

Center plate on joint unless x, y offsets are indicated. Dimensions are in ft-in-sixteenths. Apply plates to both sides of truss and fully embed teeth.

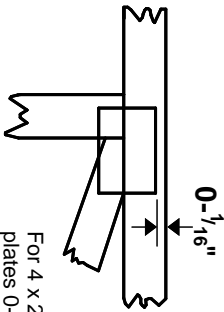

For 4 x 2 orientation, locate plates 0- 1/16" from outside edge of truss.



This symbol indicates the required direction of slots in connector plates.

* Plate location details available in **MITek 20/20 software** or upon request.

PLATE SIZE

4 X 4

The first dimension is the plate width measured perpendicular to slots. Second dimension is the length parallel to slots.

LATERAL BRACING LOCATION

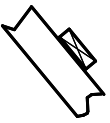

Indicated by symbol shown and/or by text in the bracing section of the output. Use T or I bracing if indicated.

BEARING

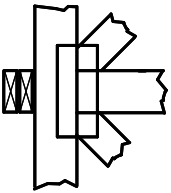

Indicates location where bearings (supports) occur. Icons vary but reaction section indicates joint number where bearings occur. Min size shown is for crushing only.

Industry Standards:

ANSI/TPI 1: National Design Specification for Metal Plate Connected Wood Truss Construction.
DSB-89: Design Standard for Bracing, Building Component Safety Information, Guide to Good Practice for Handling, Installing & Bracing of Metal Plate Connected Wood Trusses.

Numbering System

6-4-8 dimensions shown in ft-in-sixteenths (Drawings not to scale)

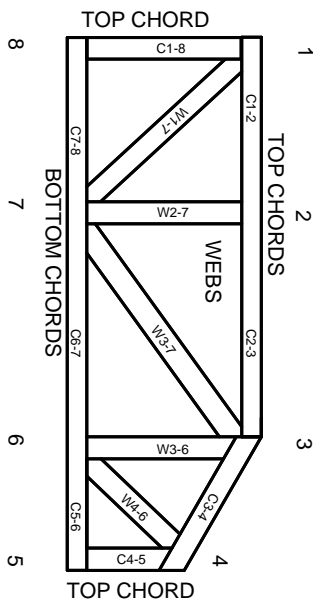

JOINTS ARE GENERALLY NUMBERED/LETTERED CLOCKWISE AROUND THE TRUSS STARTING AT THE JOINT FARTHEST TO THE LEFT.

CHORDS AND WEBS ARE IDENTIFIED BY END JOINT NUMBERS/LETTERS.

PRODUCT CODE APPROVALS

ICC-ES Reports:

ESR-1311, ESR-1352, ESR1988
ER-3907, ESR-2362, ESR-1397, ESR-3282

Trusses are designed for wind loads in the plane of the truss unless otherwise shown.

Lumber design values are in accordance with ANSI/TPI 1 section 6.3 These truss designs rely on lumber values established by others.

© 2012 MITek® All Rights Reserved



General Safety Notes

Failure to Follow Could Cause Property Damage or Personal Injury

1. Additional stability/bracing for truss system, e.g. diagonal or X-bracing, is always required. See BCSI.
2. Truss bracing must be designed by an engineer. For wide truss spacing, individual lateral braces themselves may require bracing, or alternative T or I bracing should be considered.
3. Never exceed the design loading shown and never stack materials on inadequately braced trusses.
4. Provide copies of this truss design to the building designer, erection supervisor, property owner and all other interested parties.
5. Cut members to bear tightly against each other.
6. Place plates on each face of truss at each joint and embed fully. Knots and wane at joint locations are regulated by ANSI/TPI 1.
7. Design assumes trusses will be suitably protected from the environment in accord with ANSI/TPI 1.
8. Unless otherwise noted, moisture content of lumber shall not exceed 19% at time of fabrication.
9. Unless expressly noted, this design is not applicable for use with fire retardant, preservative treated, or green lumber.
10. Camber is a non-structural consideration and is the responsibility of truss fabricator. General practice is to camber for dead load deflection.
11. Plate type, size, orientation and location dimensions indicated are minimum plating requirements.
12. Lumber used shall be of the species and size, and in all respects, equal to or better than that specified.
13. Top chords must be sheathed or purlins provided at spacing indicated on design.
14. Bottom chords require lateral bracing at 10 ft. spacing, or less, if no ceiling is installed, unless otherwise noted.
15. Connections not shown are the responsibility of others.
16. Do not cut or alter truss member or plate without prior approval of an engineer.
17. Install and load vertically unless indicated otherwise.
18. Use of green or treated lumber may pose unacceptable environmental, health or performance risks. Consult with project engineer before use.
19. Review all portions of this design (front, back, words and pictures) before use. Reviewing pictures alone is not sufficient.
20. Design assumes manufacture in accordance with ANSI/TPI 1 Quality Criteria.
21. The design does not take into account any dynamic or other loads other than those expressly stated.



MITek Engineering Reference Sheet: Mill-7473 rev. 5/19/2020