

Lawrence E. Bennett, P.E.
Civil & STRUCTURAL ENGINEERING

P.O. Box 214368
 South Daytona, FL 32121-4368
 Phone (386) 767-4774
 E-Mail: lebbe@bellsouth.net
 Website: http://www.lebbe.com
 Fax (386) 767-6556

SITE SPECIFIC JOB CHECK LIST

Date: _____

1. Job name and address: _____

2. Your company name and address. You must include a physical address so we can send it back via UPS.

3. Briefly describe any information relevant to the job. _____

4. The drawings must have the following minimum standards:

- a. Job name and address, your address **ON ALL PAGES OF PLAN**
- b. Plan view with dimensions **TO SCALE.**
- c. Section view or front and side elevations to 1/4" = 1' **SCALE.** (1/8" or 1/10" for pool enclosures.)
Gable & mansard side walls shall include the roof vertical rise and length.
- d. Provide attachment details on drawing.
- e. Wall sections at typical wall and any beam bearing points.
- f. Street map with job location.
- g. Wind zone _____ m.p.h. and exposure category B _____ or C _____ (From Building Department.)
- h. Complete Design Checklist. Copies are in the back of the manual.

5. Other comments: _____

F:_sitespecificcklist.doc

Design Check List for Structures w/ Wood and / or Aluminum Framing Components (page 1 of 1)

1. Design Statement: These plans have been designed in accordance with the Aluminum Structures Design Manual by Lawrence E. Bennett and comply with the Florida Building Code, 2004 Edition, Chapter 20 and ASCE 7-98, Table 6-2; Importance Factor 1.00; Exposure 'B', 'C' or 'D'; 120 MPH or MPH for 3 second wind gust velocity load. Partially Enclosed or Enclosed; Door & window design pressures can be found on page 3-70:
- a. 'A' exposure, INT = for 10 SF (-) _____ PSF; for 50 SF (+) _____ PSF
 - b. 'B' exposure, EXT = for 10 SF (-) _____ PSF; for 50 SF (+) _____ PSF
 - 3 second wind gust velocity load: Partially Enclosed or Enclosed; design pressures can be found on page 4-11:
 - a. 'B' exposure = _____ PSF for Roofs & _____ PSF for Walls.
 - b. 'C' exposure = _____ PSF for Roofs & _____ PSF for Walls.
- Negative I.P.C. 0.18 for Enclosed or 0.55 for Partially Enclosed
 For 'C' exposure design loads, multiply 'B' exposure loads by 1.4.
2. Host Structure Adequacy Statement: I certify that I have inspected the host structure and it is in good repair and attachments made to the structure will be solid.

Contractor / Authorized Rep. * Name (please print) _____ Phone: _____

Contractor / Authorized Rep. * Signature _____ Date: _____

Note: Projection of room from host structure shall not exceed 16".

3. Building Permit Application Package contains the following:
- A. Project name & address on plans Yes No
 - B. Site plan or survey with enclosure location Yes No
 - C. Contractor's / Designer's name, address, phone number, & signature on plans Yes No
 - D. Notice of consumer rights attached and initialed by consumer Yes No
 - E. Floor plan layout drawing @ 1/4" scale with the following:
 - 1. Plan view with host structure, enclosure length, and projection from host structure Yes No
 - 2. Front and side elevation views with all dimensions & heights Yes No

4. Highlight details from Aluminum Structures Design Manual:

- A. Roof panel tables from section 7 Yes No
 - B. Beam span, spacing, & size. Use section 3 beam tables for enclosed or partially enclosed structures. Yes No
- Beam allowable span conversions from 120 MPH wind zone, 'B' Exposure to _____ MPH wind zone and/or 'C' Exposure for load width _____.
 Look up span on 120 MPH table and apply the following formula:

Span / Height @ 120 MPH $\left[\frac{0.00}{(b \text{ or } d) \times 1.00} (b \text{ or } d) \times 1.00 \right]$ Required Span @ _____ MPH

- C. Fourth wall details Yes No
- D. Knee braces length, location & size (i.e. 2" x 3" x 0.045" for 2" x 8" x 0.072" x 0.224" S.M.B.) Yes No
- E. Wall sections, framing details, & specifications Yes No
- F. Header tables w/ lengths Yes No
- G. Wood deck & girder tables w/ lengths Yes No
- H. Residential handrail detail Yes No
- I. Connection details to be used such as:
 - 1. Girder to pair or foundation Yes No
 - 2. Wall to wood deck / slab Yes No
 - 3. Roof system details from section 7 Yes No
 - 4. Column to beam details Yes No
- J. Foundation detail type & size Yes No

* Must have attended Engineer's Continuing Education Class within last two years.

General Notes and Specifications:

- The following structures are designed for mono sloped aluminum roof systems to be married to block and wood frame structures of adequate structural capacity. The contractor / home owner shall verify that the host structure is in good condition and of sufficient strength to hold the proposed addition.
- If there is a question about the host structure, the owner (at his own expense) shall hire an architect, engineer, or a certified home inspection company to verify host structure capacity.
- The structures designed using this section shall be limited to a maximum projection of 16' from the host structure. Freestanding structures shall be limited to the maximum spans and size limits of component parts. Larger than these limits shall have site specific engineering.
- The following rules apply to attachments involving mobile and manufactured homes:
 - Structures to be placed adjacent to a mobile / manufactured home built prior to 1994 shall use "fourth wall construction" or shall provide detailed plans of the mobile / manufactured home and inspection report along with addition plans for site specific review and seal by the engineer. This applies to all screen / glass rooms, and / or other structures to be attached.
 - "Fourth wall construction" means the addition shall be free standing with only the roof flashing of the two units being attached. The most common "fourth wall construction" is a post and beam frame adjacent to the mobile / manufactured home. The same span tables can be used as for the front wall beam. For "fourth wall" beam use the miscellaneous beam tables from Section 3B. The post shall be sized according to this manual and / or as a minimum be a 2" x 3" x 0.050" with an 18" x 2" x 2" x 0.044" knee brace at each end of the beam.
 - For mobile / manufactured homes built after 1994 structures may be attached to the home provided the project follows the plan for attachment of this manual. The contractor / owner shall provide verification of the structural system used to build the host structure.
 - If the mobile / manufactured home manufacturer certifies in writing that the mobile / manufactured home may be attached to, then a "fourth wall" is not required.
- Section 7 of this manual contains span tables and attachment details for pans and composite panels.
- Screen walls between existing walls, floors, and ceilings shall be allowed and spans shall be figured the same as other screen walls.
- When using tek screws in lieu of S.M.S. longer screws must be used to compensate for drill head.
- For high velocity hurricane zones the minimum live load / applied load shall be 30 PSF.
- Loads to be used for decks are for residential only and are 40 #Sq. Ft. live load with 5 #Sq. Ft. or 15 #Sq. Ft. dead load added to joists and with 15 #Sq. Ft. dead load added to girders.
- Spans may be interpolated between values but not extrapolated outside values.
- Aluminum shall not be used in direct contact w/ CCA or ACO treated lumber. Hot dipped (ASTM STD A) galvanized or 316 stainless steel fasteners shall be used on CCA & ACO treated lumber.

Section 4 Design Statement:

The structures designed for Section 4 are solid roofs and screen or solid walls and are considered part of an enclosed structural system since they are designed to be married to an existing structure.

The design wind loads used for glass rooms are from ASCE 7-98 Section 6.5. Analytical Procedure and are in compliance with the 2004 Florida Building Code. Separate load tables are provided for enclosed and partially enclosed systems. The loads assume a mean roof height of less than 30', roof slope of 20° to 30° (+/- 10°), $I = 1.00$. Negative internal pressure coefficient is 0.18 for enclosed and 0.55 for partially enclosed structures. All pressures shown in the below table are in PSF (#SF).

Anchors for composite panel roof systems were computed on a load width of 10' and 16' projection with a 2' overhang. Any greater load width shall be site specific.

General Notes and Specifications for Section 4 Tables:

Design Loads for Sheds or Solid Wall Rooms

| Wind Speed (MPH) | Enclosed Roof | Enclosed Wall | Over Hang All Roofs |
|------------------|---------------|---------------|---------------------|
| 100 MPH | +20 / -20 | +15 / -13 | +20 / -30 |
| 110 MPH | +20 / -23 | +18 / -15 | +20 / -36 |
| 120 MPH | +20 / -27 | +22 / -18 | +20 / -43 |
| 130 MPH | +20 / -29 | +23 / -19 | +20 / -45 |
| 140 MPH | +20 / -32 | +25 / -21 | +20 / -50 |
| 140A MPH | +30 / -37 | +28 / -25 | +30 / -58 |
| 140B MPH | +30 / -37 | +29 / -25 | +30 / -58 |
| 150 MPH | +30 / -43 | +34 / -28 | +30 / -67 |

- Note
- Framing systems of screen, vinyl, and glass rooms are considered to be main frame resistance components. Wind loads are listed as minus loads for roofs and plus loads for walls.
 - All loads are based on the analytical method of ASCE 7-98.
 - For window & door pressures use Section 3 table page 3-70.

Conversion Table 4A
Wind Zone Conversions for Sheds or Solid Wall Rooms
From 120 MPH Wind Zone to Others

| Wind Zone MPH | Roofs | | | Walls | | | Overhangs | | |
|---------------|-----------------|----------------|-------------|-----------------|----------------|-------------|-----------------|----------------|-------------|
| | App. Load (#SF) | Deflection (d) | Bending (b) | App. Load (#SF) | Deflection (d) | Bending (b) | App. Load (#SF) | Deflection (d) | Bending (b) |
| 100 | 20 | 1.11 | 1.16 | 15 | 1.14 | 1.21 | 30 | 1.13 | 1.20 |
| 110 | 23 | 1.05 | 1.08 | 18 | 1.07 | 1.11 | 36 | 1.08 | 1.09 |
| 120 | 27 | 1.00 | 1.00 | 22 | 1.00 | 1.00 | 43 | 1.00 | 1.00 |
| 130 | 29 | 0.98 | 0.96 | 23 | 0.99 | 0.98 | 45 | 0.98 | 0.98 |
| 140 | 32 | 0.94 | 0.92 | 25 | 0.96 | 0.94 | 50 | 0.95 | 0.93 |
| 140A | 37 | 0.90 | 0.85 | 29 | 0.91 | 0.87 | 58 | 0.91 | 0.86 |
| 140B | 37 | 0.90 | 0.85 | 29 | 0.91 | 0.87 | 58 | 0.91 | 0.86 |
| 150 | 43 | 0.86 | 0.79 | 34 | 0.86 | 0.80 | 67 | 0.86 | 0.80 |

Conversion Table 4B
from Enclosed to Partially Enclosed Building Classification

| Roof | Walls |
|----------------|-------|
| deflection (d) | 0.92 |
| bending (b) | 0.90 |

Conversion Table 4C
Multipliers Based on Mean Roof Height of Host Structure

| Mean Host from Exposure "B" to "C" | for Loads | Multipliers Deflection (d) | Bending (b) |
|------------------------------------|-----------|----------------------------|-------------|
| 0 to 15'-0" | 0.94 | 0.94 | 0.91 |
| 15'-0" to 20'-0" | 0.92 | 0.92 | 0.88 |
| 20'-0" to 25'-0" | 0.91 | 0.91 | 0.86 |
| 25'-0" to 30'-0" | 0.89 | 0.89 | 0.85 |

X (SEE TABLES 4.4, 4.5, 1, 2)

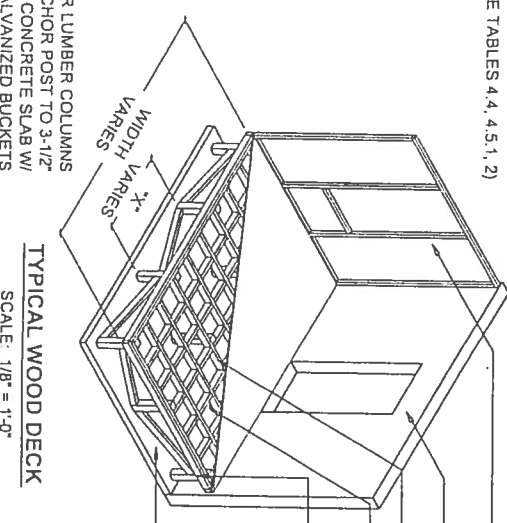

- ALL WALL FRAMING 16" O.C. (EXCEPTION: 24" O.C. FOR WOOD STORAGE ROOM)
- PIER POST CAN BE BOLTED TO SLAB OR CONTINUOUS FOOTER OR HAVE ISOLATED CONCRETE FOOTER EACH PIER (SEE DETAIL)
- CENTER STRINGER MAY BE REQUIRED (SEE TABLE 4.5, 1 AND 4.5, 2)
- HURRICANE ANCHOR EACH JOIST TO CENTER STRINGER W/ SIMPSON HS
- OPEN DECKS OVER 30" IN HEIGHT ABOVE GRADE HAVE A GUARD RAIL SYSTEM

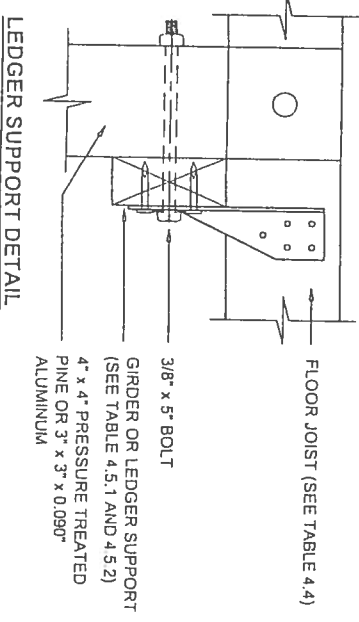

(OPTIONAL) WOOD FRAME WALL

- HOST STRUCTURE
SEE WALL SECTIONS
CENTER LEDGER PIER
BRIDGING @ 48" O.C.
- 2 x 6 JOIST HANGER EACH END
- BRACING REQUIRED FOR HEIGHT OVER 4'-0". USE 2 x 4 #2 P.T.P. NAILED OR BOLTED AND BRACING FASTENINGS. WOOD POST 4# 8d COMMON TOE NAILED OR 3# 10d COMMON FOR LAPPED BRACING OR 1-3/8" x (LUMBER THICKNESS + 1/2"), ALUMINUM POST LAPPED BRACING ONLY USE 1-3/8" x (POST THICKNESS + 1/2") (MAX. HGT. 8'-0")

- VAPOR BARRIER (OPTIONAL)
15# FELT PAPER, TYVECK,
FOIL BACKED 3/4" OR 1/2"
FOAM INSULATION
OR CDX PLYWOOD
VAPOR BARRIER REQUIRED FOR ALL ADDITIONS EXCEPT SHEDS, 0.006 MIN. VISQUEEN, 15# FELT PAPER, THERMAL PLY OR FOIL BACKED INSULATION
- VINYL SIDING TYPICAL
FOIL TAPE ALL JOINTS
HEADER AS REQUIRED FOR SPAN (FOR HEADER SIZES SEE TABLE 4.3)

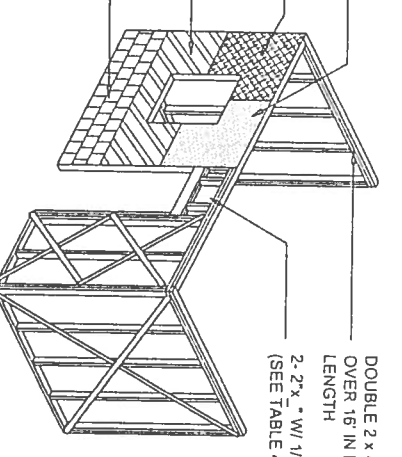

- NOTES:
- SIDING IS TO BE FASTENED @ 16" O.C. TO MANUFACTURERS SPECIFICATIONS AND INSTRUCTIONS AS SUPPLIED BY THE SIDING COMPANY
 - NAILING SIDING OVER FURRING STRIPS: 1" SHANK ALUMINUM NAILS OR EQUAL SIDING OVER FOAM: 1-3/4" SHANK ALUMINUM NAILS OR EQUAL
 - IF PLYWOOD IS USED FOR CORNER BRACING WITH FOIL BACKED FOAM BEING USED FOR THE VAPOR BARRIER, VISQUEEN, TAR PAPER OR SOME OTHER SUITABLE PRODUCT MUST BE USED OVER THE WOOD
 - IF A FOURTH FRAME WALL IS REQUIRED, ALL FRAMING AND BRACING SHALL BE THE SAME AS FOR OTHER WALLS OR PROVIDE ALUMINUM OR WOOD BEAM SUPPORT WALL
 - SIDING SHALL BE APPLIED PER MANUFACTURERS SPECIFICATIONS FOR WIND ZONE OR PROJECT AND OVER PROPERLY PREPARED WALL WITH BRACING OR SHEATHING
 - BRACING FOR CORNERS SHALL BE 1/2" 4 PLY CDX PLYWOOD FOR WOOD STUDS @ 24" O.C. NAILED W/ #8d COMMON 8" O.C. EDGES AND 12" O.C. FIELD
 - ALTERNATE BRACING SHALL BE 1-1/4" x 1 1/4" GA. GALVANIZED COIL STRAP X-BRACED TO STUDS W/ (1) #8d COMMON PER STUD OR 1-1/4" x 0.050" ALUMINUM STRAP X-BRACED AND NAILED TO STUDS W/ (2) 1-1/4" ALUMINUM NAILS EACH STUD
 - STRUCTURAL GRADE THERMAL PLY OVER STUDS SHALL BE 16" O.C. AND NAILING OR SCREW PATTERN SAME AS CDX WITH NAILS OR SCREWS PER MANUFACTURERS SPECIFICATIONS
 - THESE SPECIFICATIONS MAY BE USED FOR FRAMING IN OPENINGS IN EXISTING STRUCTURES.

TYPICAL WOOD FRAME ATTACHED TO HOST STRUCTURE

SCALE: 1/8" = 1'-0"

PURSUANT TO PROVISIONS OF THE FLORIDA DEPARTMENT OF HIGHWAY SAFETY & MOTOR VEHICLES DIVISION OF MOTOR VEHICLES RULE 15C-2, THE SPAN TABLES, CONNECTION DETAILS, ANCHORING AND OTHER SPECIFICATIONS ARE DESIGNED TO BE MARRIED TO CONVENTIONALLY CONSTRUCTED HOMES AND / OR MANUFACTURED HOMES AND MOBILE HOMES CONSTRUCTED AFTER 1994.

07-08-2004

Lawrence E. Bennett, P.E.
FL # 16644
CIVIL ENGINEER - DEVELOPMENT CONSULTANT
P.O. BOX 214368, SOUTH DAYTONA, FL 32121
TELEPHONE: (386) 767-4774
FAX: (386) 767-6556

STRUCTURES WITH WOOD FRAME WALLS & ALUMINUM ROOF SYSTEMS
ALUMINUM STRUCTURES DESIGN MANUAL
2004 FLORIDA BUILDING CODE
MAY 2004 EDITION
SECTION 4 DETAILS

JOB NAME: _____

ADDRESS: _____

DRAWING FOR ONE PERMIT ONLY

2004

OF

8

JAN 01 2005

1

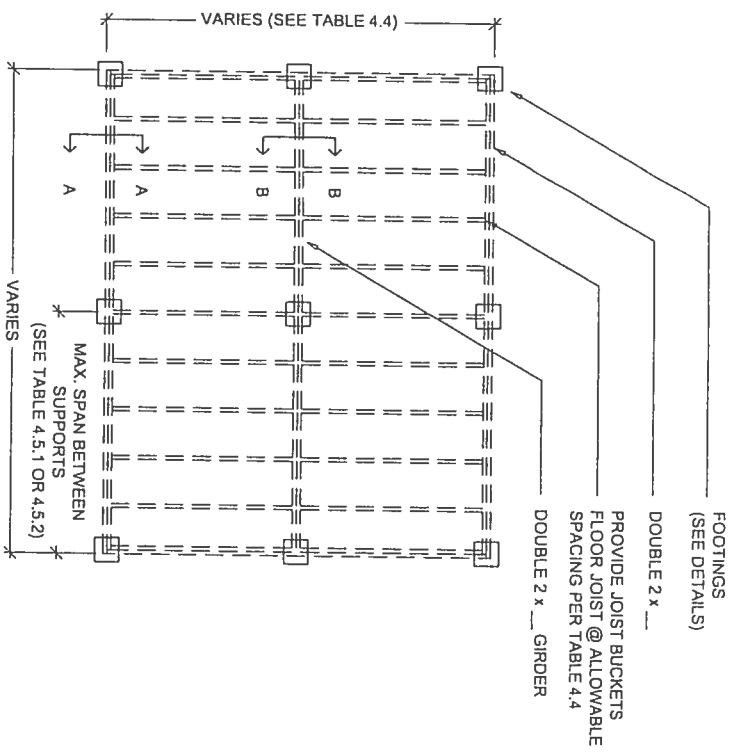

DECKING MAY BE 5/8" OR 3/4" PLYWOOD OR 5/4" x 6" OR 2 x 6 PLANKING (SEE SECTIONS)

TYPICAL WOOD DECK FRAMING PLAN

SCALE: 1/8" = 1'-0"

REMOVE VINYL SIDING AND SOFFIT ON THE WALL AND INSTALL SIMPSON CS-16 COIL STRAP OR EQUAL FROM TRUSS / RAFTER TO BOTTOM OF DOUBLE TOP PLATE JOIST @ EACH TRUSS / RAFTER

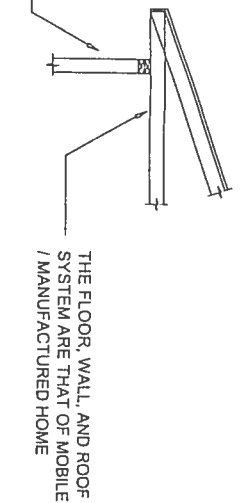

NAIL STRAP W/ 16d COMMON @ TRUSS RAFTER AND PERIMETER JOIST

SCREW COIL STRAP TO SHEATHING W/ #8 x 1" DECK SCREWS @ 16" O.C. VERTICALLY

REPLACE VINYL SIDING

PROVIDE NEW 4" x 6" OR 8" x 16" CMU PIER AND SOLID FOUNDATION BLOCK @ 5'-0" MAX. O.C. ALONG ATTACHMENT WALL

TYPICAL WALL SECTION FOR ATTACHMENT TO MOBILE / MANUFACTURED HOME

SCALE: 1/4" = 1'-0"

REMOVE VINYL SIDING AND SOFFIT ON THE WALL AND INSTALL SIMPSON CS-16 COIL STRAP OR EQUAL FROM TRUSS / RAFTER TO BOTTOM OF DOUBLE TOP PLATE JOIST @ EACH TRUSS / RAFTER

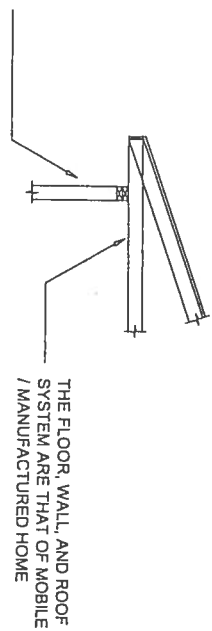

THE FLOOR, WALL, AND ROOF SYSTEM ARE THAT OF MOBILE / MANUFACTURED HOME

REMOVE VINYL SIDING AND SOFFIT ON THE WALL AND INSTALL SIMPSON CS-16 COIL STRAP OR EQUAL FROM TRUSS / RAFTER TO BOTTOM OF DOUBLE TOP PLATE JOIST @ EACH TRUSS / RAFTER

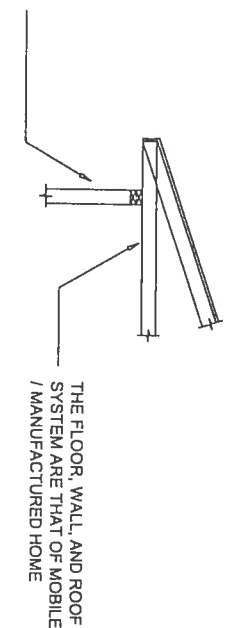

THE FLOOR, WALL, AND ROOF SYSTEM ARE THAT OF MOBILE / MANUFACTURED HOME

3/4" PRESSURE TREATED PLYWOOD OR 2 x 6 PRESSURE TREATED DECKING

CONCRETE BLOCK OR P.T.P. WOOD PIERS CONSTRUCTED ON 4" x 16" x 16" CONCRETE FOOTING PAD

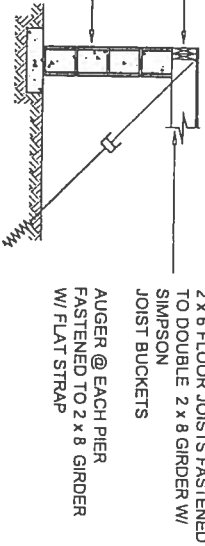

ALTERNATE FOOTING TO DECK CONNECTION SECTION A-A

SCALE: 1/4" = 1'-0"

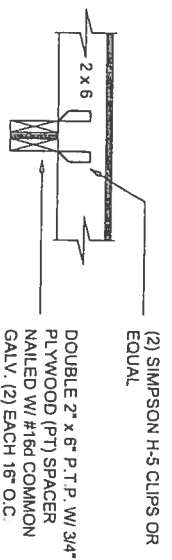

CENTER OF GIRDER B-B

SCALE: 1/2" = 1'-0"



RIBBON FOOTING

SCALE: 1/2" = 1'-0"

| Wind Zone | # / Sq. Ft. | x | Post Anchor @ 48" O.C. | Stud Anchors |
|------------|-------------|-------|------------------------|----------------|
| 100 - 123 | + 20 - 29 | 1'-1" | ABU 44 | SP1 @ 16" O.C. |
| 130 - 140A | + 30 - 37 | 1'-4" | ABU 44 | SPH @ 48" O.C. |
| 140B - 150 | + 30 - 43 | 1'-9" | CBQ44-SDS2 | SPH @ 32" O.C. |

Minimum 18" projection from host structure.

* For stud walls use 1/2" x 8" L-Bolts @ 48" O.C. and 2" square washers to attach sole plate to footing. Stud anchors shall be at the sole plate only and coil strap shall lap over the top plate on to the studs anchors and straps shall be per manufacturers specifications.

NAIL STRAP W/ 16d COMMON @ TRUSS RAFTER AND PERIMETER JOIST

SCREW COIL STRAP TO SHEATHING W/ #8 x 1" DECK SCREWS @ 16" O.C. VERTICALLY

REPLACE VINYL SIDING

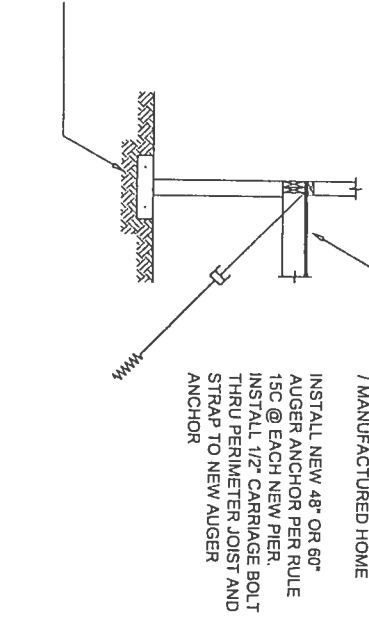

INSTALL NEW 48" OR 60" AUGER ANCHOR PER RULE 15C @ EACH NEW PIER. INSTALL 1/2" CARRIAGE BOLT THRU PERIMETER JOIST AND STRAP TO NEW AUGER ANCHOR

REMOVE VINYL SIDING AND SOFFIT ON THE WALL AND INSTALL SIMPSON CS-16 COIL STRAP OR EQUAL FROM TRUSS / RAFTER TO BOTTOM OF DOUBLE TOP PLATE JOIST @ EACH TRUSS / RAFTER

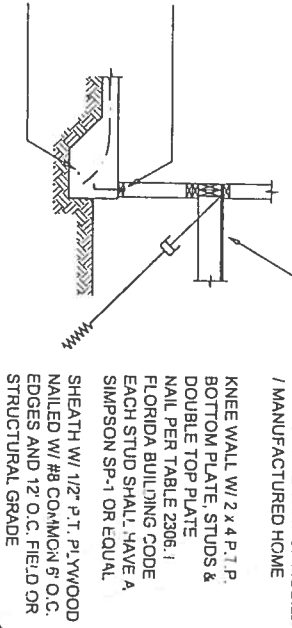

THE FLOOR, WALL, AND ROOF SYSTEM ARE THAT OF MOBILE / MANUFACTURED HOME

REMOVE VINYL SIDING AND SOFFIT ON THE WALL AND INSTALL SIMPSON CS-16 COIL STRAP OR EQUAL FROM TRUSS / RAFTER TO BOTTOM OF DOUBLE TOP PLATE JOIST @ EACH TRUSS / RAFTER

THE FLOOR, WALL, AND ROOF SYSTEM ARE THAT OF MOBILE / MANUFACTURED HOME

THE FLOOR, WALL, AND ROOF SYSTEM ARE THAT OF MOBILE / MANUFACTURED HOME

KNEE WALL W/ 2 x 4 P.T.P. BOTTOM PLATE, STUDS & DOUBLE TOP PLATE NAILED PER TABLE 2306.1 FLORIDA BUILDING CODE EACH STUD SHALL HAVE A SIMPSON SP-1 OR EQUAL.

SHEATH W/ 1/2" P.T. PLYWOOD NAILED W/ #8 COMMON 6" O.C. EDGES AND 12" O.C. FIELD OR STRUCTURAL GRADE THERMAL PLY FASTENED PER THE MANUFACTURERS SPECIFICATIONS STRAP SIMPSON COIL STRAP OVER SHEATHING

ALTERNATE WALL SECTION FOR ATTACHMENT TO MOBILE / MANUFACTURED HOME

SCALE: 1/4" = 1'-0"

Lawrence E. Bennett, P.E.
FL # 16644
CIVIL ENGINEER - DEVELOPMENT CONSULTANT
P.O. BOX 214368, SOUTH DAYTONA, FL 32121
TELEPHONE: (386) 767-4774
FAX: (386) 767-6556

STRUCTURES WITH WOOD FRAME WALLS & ALUMINUM ROOF SYSTEMS
ALUMINUM STRUCTURES DESIGN MANUAL
2004 FLORIDA BUILDING CODE
MAY 2004 EDITION
SECTION 4 DETAILS

2

1

2006

8

07-08-2004

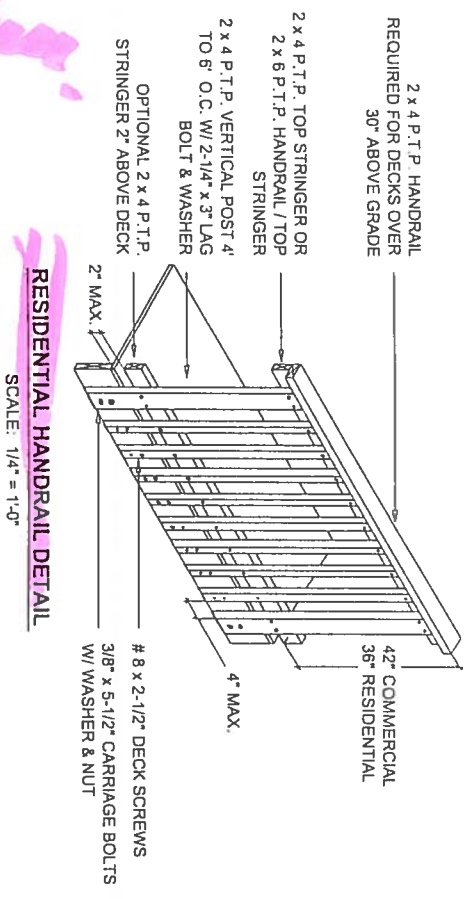

RESIDENTIAL HANDRAIL DETAIL
SCALE: 1/4" = 1'-0"

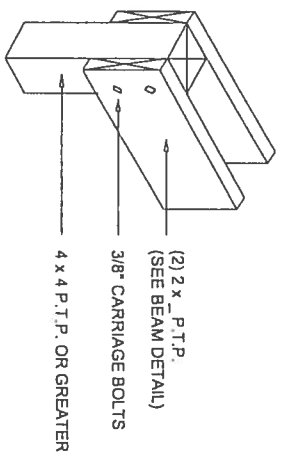

ALTERNATE DECK POST TO BEAM CONNECTION DETAIL
SCALE: 1/2" = 1'-0"

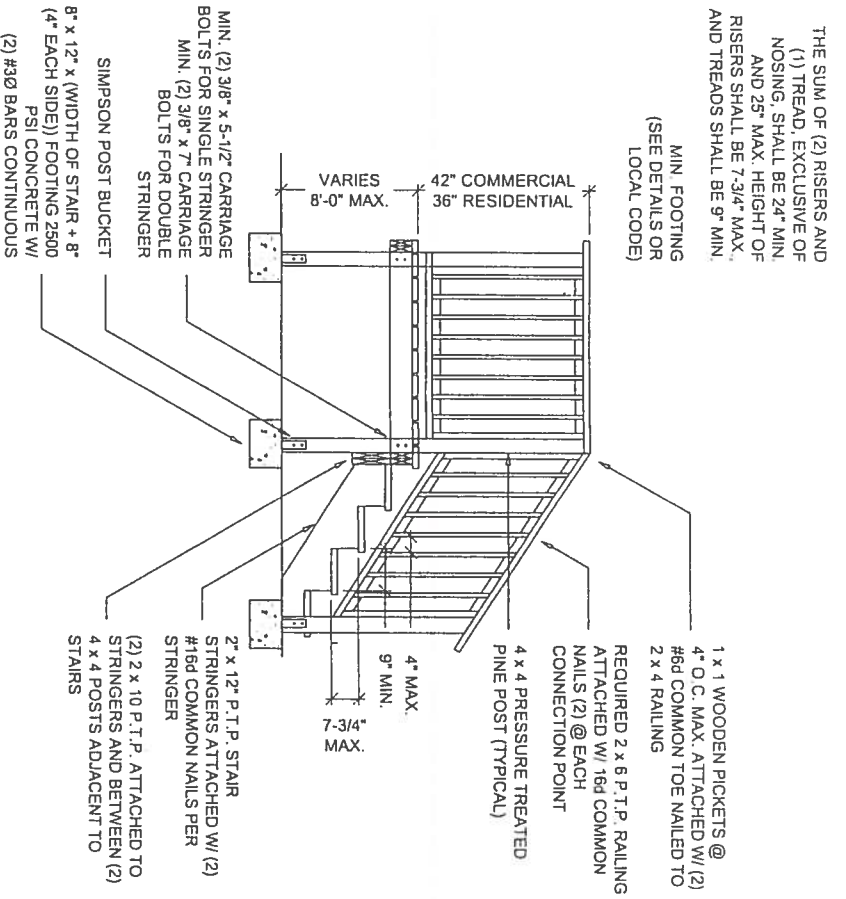

WOOD STAIR SECTION DETAIL
SCALE: 1/4" = 1'-0"

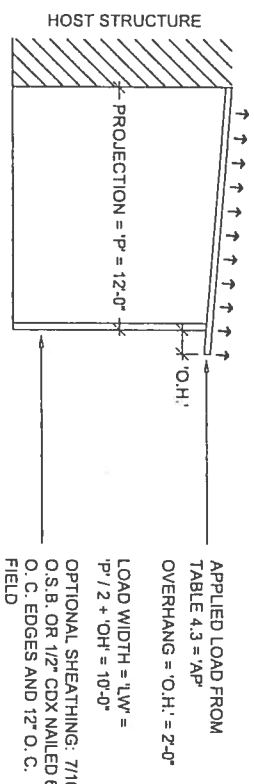

WALL UPLIFT EXAMPLE
SCALE: 1/8" = 1'-0"

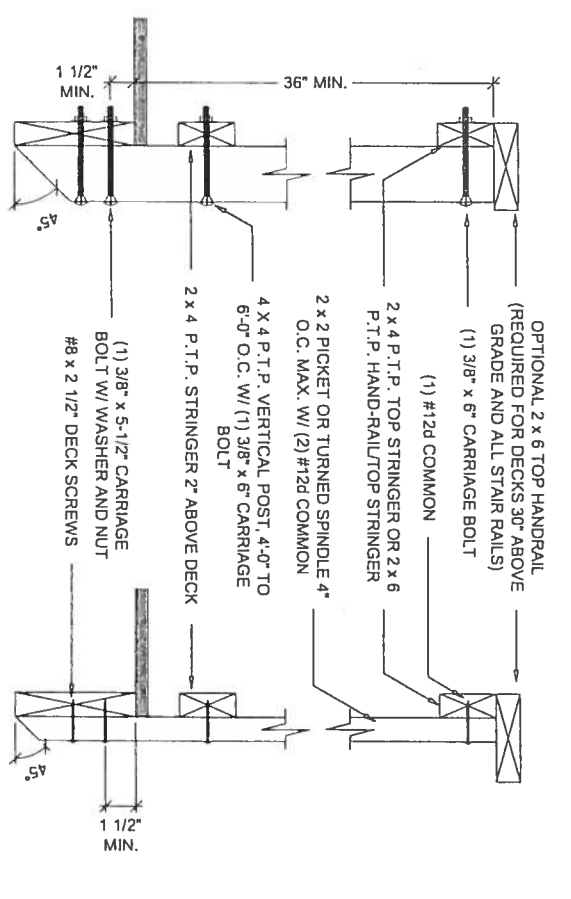

POST TO JOIST DETAIL

PICKET TO JOIST DETAIL

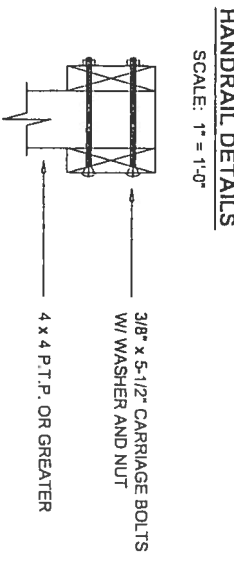

HANDRAIL DETAILS
SCALE: 1" = 1'-0"

ALTERNATE POST TO DECK BEAM DETAIL
SCALE: 1" = 1'-0"

THE SUM OF (2) RISERS AND (1) TREAD, EXCLUSIVE OF NOSING, SHALL BE 24" MIN. AND 25" MAX. HEIGHT OF RISERS SHALL BE 7.34" MAX. AND TREADS SHALL BE 9" MIN. (SEE DETAILS OR LOCAL CODE)

Anchor Schedule

| | |
|--------------|-------------------|
| Stud Spacing | H 2.5A Spacing |
| 12" O.C. | Alternating Studs |
| 16" O.C. | Each Stud |
| 24" O.C. | Each Stud |

Allowable Uplift Per Anchor

| | |
|-------------|---------------|
| Simpson | Uplift Rating |
| H 2.5A | 600# |
| H 3.0 & 5.0 | 455# |
| H 6.0 | 915# |
| MASTC® | 1,250# |
| MASTC® | 2,750# |

Wind Load Conversion Table:

| Region | Applied Load | Conversion Factor |
|--------|--------------|-------------------|
| 100 | 19 | 1.19 |
| 110 | 23 | 1.08 |
| 120 | 27 | 1.00 |
| 123 | 29 | 0.97 |
| 130 | 32 | 0.92 |
| 140 | 37 | 0.85 |
| 150 | 43 | 0.79 |

REQUIRED ANCHOR SPACING CAN BE FOUND BY DIVIDING ANCHOR CAPACITY BY THE UPLIFT VALUE PREVIOUSLY DETERMINED.
EXAMPLE: FOR AN H-3.0 CAPACITY = 415 # / 270 # / L.F. = SPACING OF 1.537 FT. THUS, STUDS AT TYPICAL SPACINGS RECEIVE ANCHORS AS FOLLOWS

APPLIED LOAD FROM TABLE 4.3 = 1AP
OVERHANG = "O.H." = 2'-0"
LOAD WIDTH = LW = P / 2 + "O.H." = 10'-0"
OPTIONAL SHEATHING: 7/16" O.S.B. OR 1/2" CDX MAILED 6" O.C. EDGES AND 12" O.C. FIELD

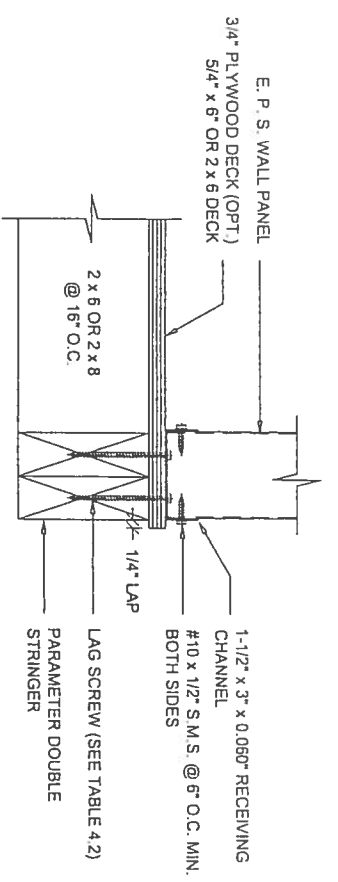

COMPOSITE PANEL WALL TO WOOD DECK
SCALE: 2" = 1'-0"

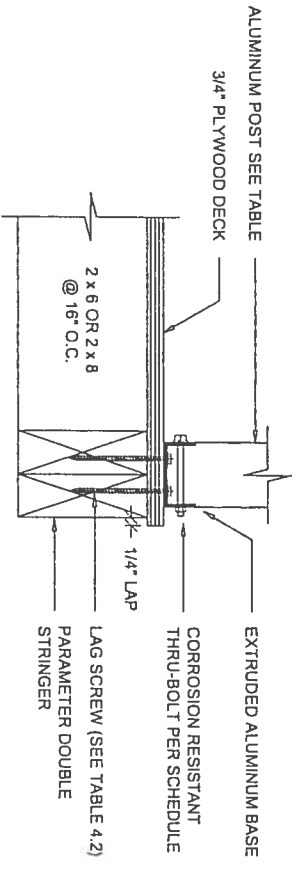

TUBE COLUMN BASE SCHEMATIC (INTERNAL BASE)
SCALE: 2" = 1'-0"

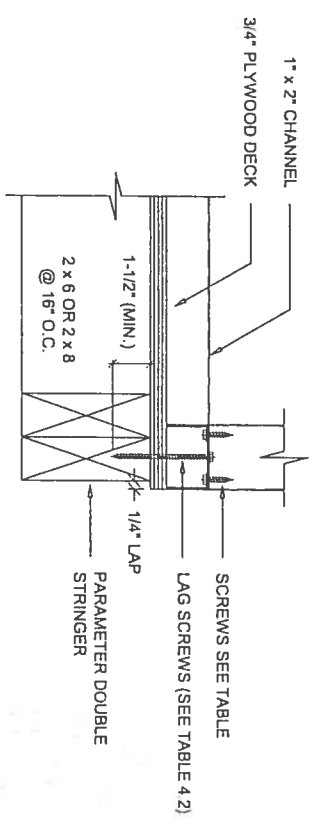

SCREEN ROOM WALL TO WOOD DECK
SCALE: 2" = 1'-0"

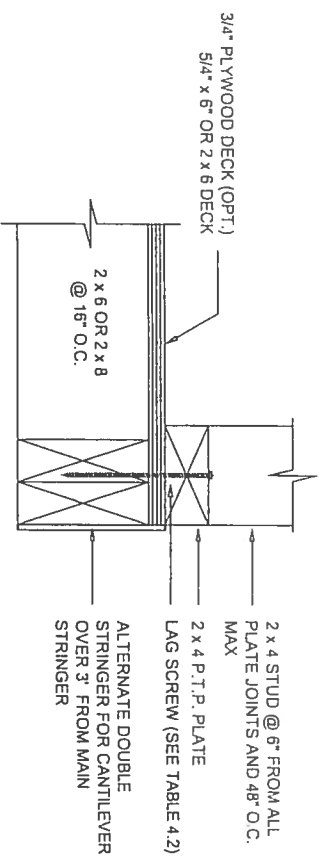

WOOD FRAME WALL TO WOOD DECK
SCALE: 2" = 1'-0"

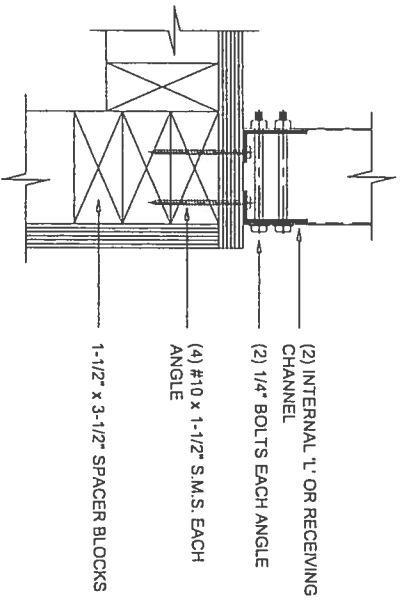

ALUMINUM BEAM FRAMING TO CORNER OF WOOD UTILITY SHED
PLAN VIEW
SCALE: 2" = 1'-0"

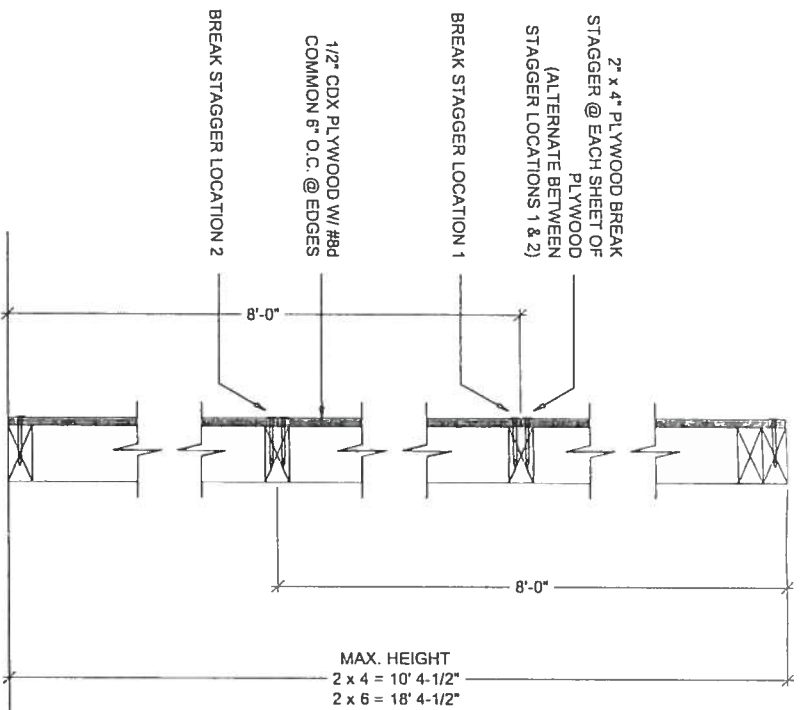

MAXIMUM HEIGHT & BREAK OF PLYWOOD SHEETS
FRAME WALL DETAIL
SCALE: 1" = 1'-0"

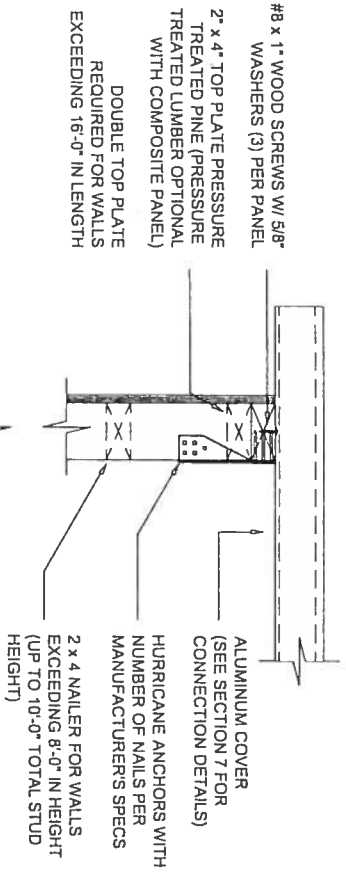

TYPICAL UTILITY SHED WALL SECTION
SCALE: 1" = 1'-0"

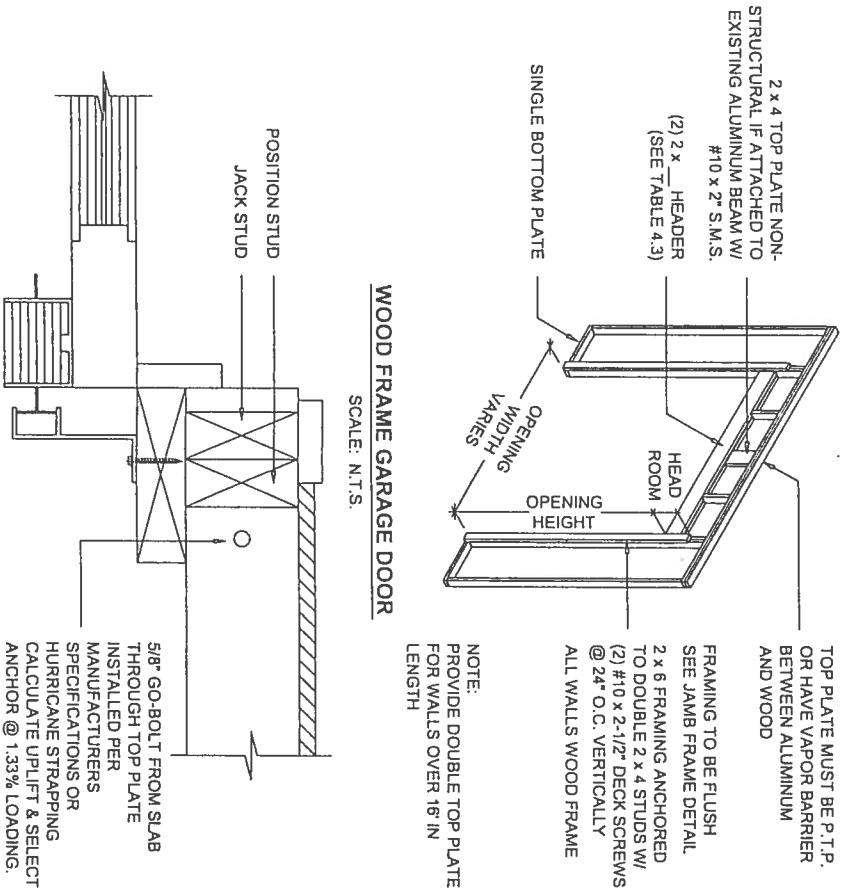

WOOD FRAME GARAGE DOOR
SCALE: N.T.S.

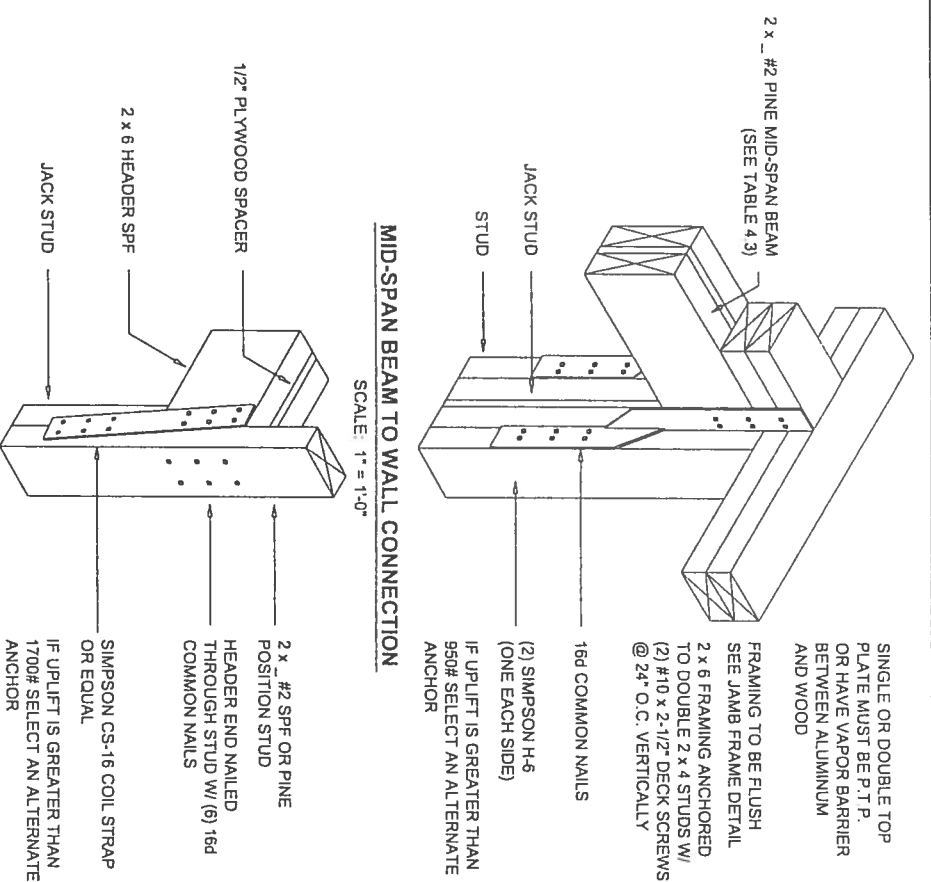

MID-SPAN BEAM TO WALL CONNECTION
SCALE: 1" = 1'-0"

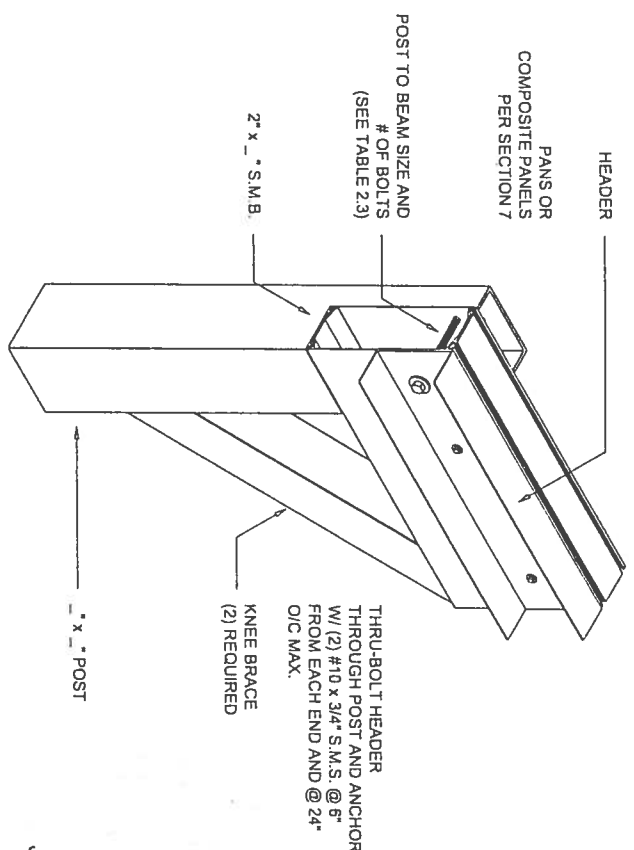

ALTERNATE 4TH WALL BEAM CONNECTION DETAIL
SCALE: N.T.S.

3/4" PLYWOOD DECK (OPT.)
5/4" x 6" OR 2" x 6 DECK

2 x 4 STUD @ 6" FROM ALL PLATE JOINTS AND 48" O.C. MAX

2 x 4 P.T.P. PLATE LAG SCREW (SEE TABLE 4.2)

ALTERNATE DOUBLE STRINGER FOR CANTILEVER OVER 3' FROM MAIN STRINGER

(2) INTERNAL 'L' OR RECEIVING CHANNEL

(2) 1/4" BOLTS EACH ANGLE

(4) #10 x 1-1/2" S.M.S. EACH ANGLE

1-1/2" x 3-1/2" SPACER BLOCKS

2 x 4 TOP PLATE PRESSURE TREATED PINE (PRESSURE TREATED LUMBER OPTIONAL WITH COMPOSITE PANEL)

DOUBLE TOP PLATE REQUIRED FOR WALLS EXCEEDING 16'-0" IN LENGTH

SHEATHING: 1/2" PLYWOOD OR STRUCTURAL GRADE THERMAL PLY W/ SIDING

2 x 4 STUDS

ALUMINUM COVER (SEE SECTION 7 FOR CONNECTION DETAILS)

HURRICANE ANCHORS WITH NUMBER OF NAILS PER MANUFACTURER'S SPECS

2 x 4 NAILER FOR WALLS EXCEEDING 8'-0" IN HEIGHT (UP TO 10'-0" TOTAL STUD HEIGHT)

2 x 4 TOP PLATE NON-STRUCTURAL IF ATTACHED TO EXISTING ALUMINUM BEAM W/ #10 x 2" S.M.S. (2) 2" HEADER (SEE TABLE 4.3)

SINGLE BOTTOM PLATE

OPENING WIDTH VARIES

OPENING HEIGHT

HEAD ROOM

TOP PLATE MUST BE P.T.P. OR HAVE VAPOR BARRIER BETWEEN ALUMINUM AND WOOD

FRAMING TO BE FLUSH SEE JAMB FRAME DETAIL

2 x 6 FRAMING ANCHORED TO DOUBLE 2 x 4 STUDS W/ (2) #10 x 2-1/2" DECK SCREWS @ 24" O.C. VERTICALLY

ALL WALLS WOOD FRAME

NOTE: PROVIDE DOUBLE TOP PLATE FOR WALLS OVER 16' IN LENGTH

5/8" GO-BOLT FROM SLAB THROUGH TOP PLATE INSTALLED PER MANUFACTURER'S SPECIFICATIONS OR HURRICANE STRAPPING CALCULATE UPLIFT & SELECT ANCHOR @ 1.33% LOADING.

2 x #2 PINE MID-SPAN BEAM (SEE TABLE 4.3)

FRAMING TO BE FLUSH SEE JAMB FRAME DETAIL

2 x 6 FRAMING ANCHORED TO DOUBLE 2 x 4 STUDS W/ (2) #10 x 2-1/2" DECK SCREWS @ 24" O.C. VERTICALLY

16d COMMON NAILS

(2) SIMPSON H-6 (ONE EACH SIDE)

IF UPLIFT IS GREATER THAN 1700# SELECT AN ALTERNATE ANCHOR

2 x #2 SPF OR PINE POSITION STUD

HEADER END NAILLED THROUGH STUD W/ (6) 16d COMMON NAILS

2 x #2 SPF OR PINE POSITION STUD

IF UPLIFT IS GREATER THAN 1700# SELECT AN ALTERNATE ANCHOR

SIMPSON CS-16 COIL STRAP OR EQUAL

IF UPLIFT IS GREATER THAN 1700# SELECT AN ALTERNATE ANCHOR

NOTE: FLASHING AS NECESSARY TO PREVENT WATER INTRUSION

THRU-BOLT HEADER THROUGH POST AND ANCHOR W/ (2) #10 x 3/4" S.M.S. @ 6" FROM EACH END AND @ 24" O.C. MAX.

(2) KNEE BRACE (2) REQUIRED

2" x 4" S.M.B.

POST TO BEAM SIZE AND # OF BOLTS (SEE TABLE 2.3)

POST

2004 General Notes and Specifications

- Garages, sheds and rooms built under section 4 specifications shall be limited to residential addition with 24'-0" roof span and 800 sq. ft. maximum area with aluminum roof.
- Habitable rooms shall comply with all provisions of the Florida Building Code and Specifically:
 - Roof shall have a minimum insulation value of R-19 and walls R-11. The host structure with the planned addition shall be in compliance with energy code requirements.
 - Sleeping rooms shall meet egress requirements of FBC and life safety code and shall not restrict egress from a sleeping room in the host structure.
- Stairs shall have treads of a minimum of 10" including nosing. Risers shall be 7-3/4" or less and the sum of two risers and one tread shall be not less than 24" and not more than 25". Stairs with more than four risers shall have a handrail meeting FBC requirements.
- Handrails shall be between 23" and 38" above the leading edge of the tread. Guard rails shall be a minimum of 36" for residential use only.
- Over head garage doors shall not be supported by a roof support beam. The door rail beam shall be a 2" x 6" x 0.050" x 0.120" up to 24'-0" span for garage doors and rail systems not exceeding 150#. Door openers shall have a separate support 2" x 6" x 0.050" x 0.120" up to 24'-0" span and door opener unit not exceeding 51#.
- Framing on the door wall shall be sheathed on both sides with 1/2" CDX or 7/16" OSB when the section of wall is less than 3'-0" from door to corner. A full sheet shall be cut to lap onto the door header on each side of the door. Door segments shall not be less than 1'-0" in length on the sides and 2'-0" if a center column is used.
- Double top plates shall be used on any wall projection or length greater than 12' or if top plate is spliced.
- All fasteners for ACCQ P.T.P. shall be hot dipped galvanized or stainless steel. If aluminum is to come into contact with ACCQ P.T.P. a vapor barrier shall be provided between the two.
- All wood framing and sheathing shall be in accordance with the 2004 Florida Building Code, Chapter 23, Section 2306 or as noted in the following notes.

Nailing Specifications for Wall Sheathing over #2 SPF Partially Enclosed, Mean Roof Height up to 30'; l = 1.0

| Sheathing | Wind Spd. (MPH) | Bldg. Zone | Fastener | Nail Spacing |
|---------------|-----------------|------------|-----------|--------------------------|
| 1/2" or 7/16" | 100-123 | 4 | Bd common | 12" O.C. Field, 6" Edges |
| 1/2" or 7/16" | 130 - 140A | 4 | Bd common | 6" O.C. Field, 3" Edges |
| 1/2" or 7/16" | 130 - 140A | 5 | Bd common | 8" O.C. Field, 6" Edges |
| 1/2" or 7/16" | 130 - 140A | 5 | Bd common | 4" O.C. Field, 3" Edges |

| Exposure "B" & "C" Double Top Plates | ALL | 16d common | 16" O.C. |
|---|------------|------------|------------|
| Top or Sole Plate to Stud "B" & "C" Double Top Plates | ALL | 16d common | 16" O.C. |
| A. End Nail | 100 - 140A | ALL | 16d common |
| B. Toe Nail | 100 - 140A | ALL | Bd common |

Framing and Sheathing Schedule

| Up to 120 MPH; "B" Exposure; 1/2" or 7/16" Sheathing | Connection | Fastener | Number and Spacing |
|--|-------------|--------------------------------|--------------------|
| 1. Roof to edge zones | #8d common | 3" O.C. edges & 6" O.C. field | |
| 2. Roof interior zones | #8d common | 6" O.C. edges & 12" O.C. field | |
| 3. Wall edge & interior zones | #8d common | 6" O.C. edges & 12" O.C. field | |
| Up to 120 MPH; "C" Exposure; Roof Height Up to 15'; Min. 5/8" CDX or 5/16" OSB | #10d common | 4" O.C. edges & 8" O.C. field | |
| 1. Roof to edge zones | #10d common | 6" O.C. edges & 12" O.C. field | |
| 2. Roof interior zones | #10d common | 6" O.C. edges & 12" O.C. field | |
| 3. Wall edge & interior zones | #10d common | 6" O.C. edges & 12" O.C. field | |
| 121 to 140A MPH; "B" Exposure; 1/2" or 7/16" Sheathing | #8d common | 3" O.C. edges & 6" O.C. field | |
| 1. Roof to edge zones | #8d common | 4" O.C. edges & 8" O.C. field | |
| 2. Roof interior zones | #8d common | 4" O.C. edges & 8" O.C. field | |
| 3. Wall edge & interior zones | #8d common | 4" O.C. edges & 12" O.C. field | |
| 140B to 150 MPH; "B" Exposure; Min. 19/32" Sheathing | #8d common | 4" O.C. edges & 8" O.C. field | |
| 1. Roof to edge zones | #8d common | 4" O.C. edges & 8" O.C. field | |
| 2. Roof interior zones | #8d common | 4" O.C. edges & 8" O.C. field | |
| 3. Wall edge & interior zones | #8d common | 4" O.C. edges & 12" O.C. field | |
| 140B to 150 MPH; "C" Exposure; Min. 19/32" Sheathing | #8d common | 6" O.C. edges & 6" O.C. field | |
| 1. Roof to edge & interior zones | #8d common | 6" O.C. edges & 6" O.C. field | |
| 2. Wall edge & interior zones | #10d common | 4" O.C. edges & 4" O.C. field | |
| 3. Gabled end walls | #10d common | 2 @ 18" O.C. | |
| Double top plates | #12d common | 2 @ 18" O.C. | |
| Top or Sole Plate to Studs | #16d common | 2 @ each stud | |
| End nail | #8d common | 4 @ each stud | |

FOOTING DETAILS

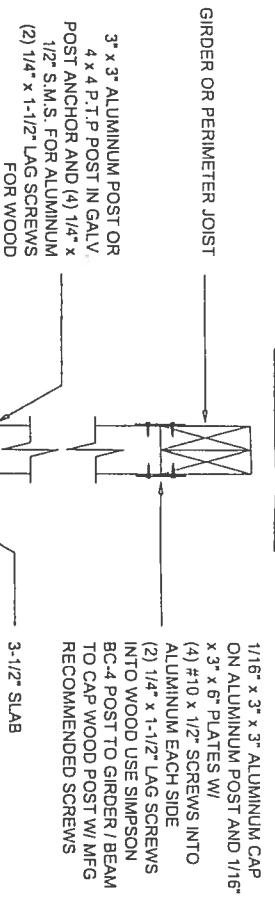

POST TO SLAB DETAIL

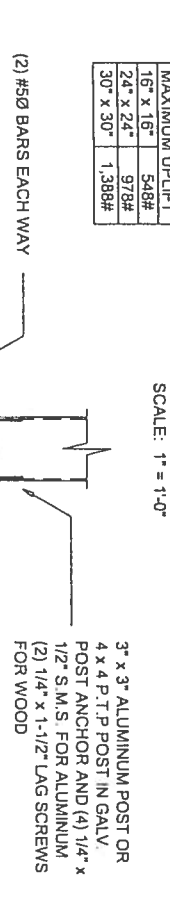

POST TO FOOTING DETAIL

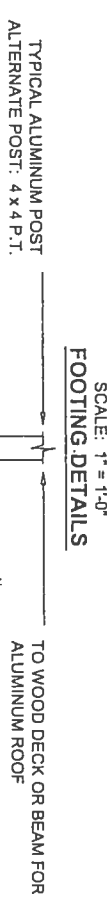

ISOLATED FOOTING

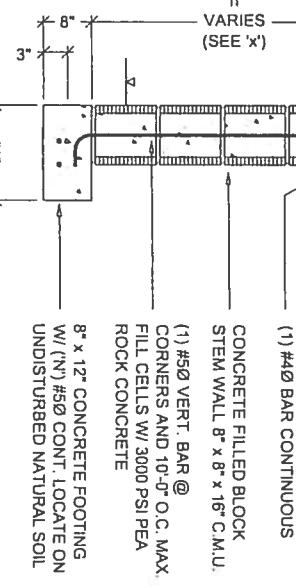
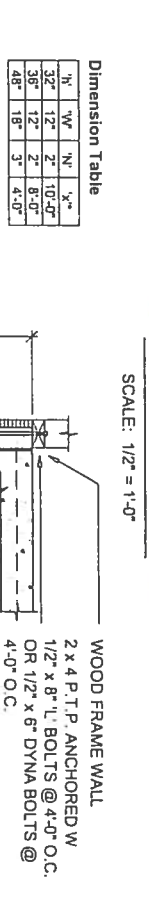

FOOTING DETAILS

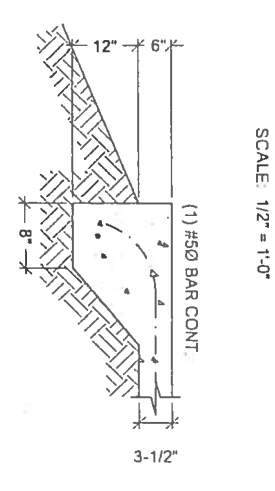

TYPE I MODERATE SLOPE FOOTING 2' / 12" - 1'-10"

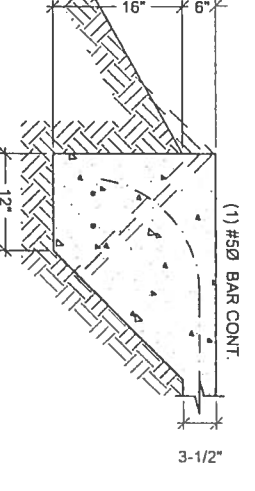

TYPE II STEEP SLOPE FOOTING > 1'-10"

- Notes:
- The foundations shown are based on a minimum soil bearing pressure of 1,500 PSF. Bearing capacity of soil must be verified, prior to placing the slab, by field soil test or a soil testing lab.
 - The slab / foundation shall be cleared of debris and roots and compacted prior to placement of concrete.
 - For structures less than 200 sq. ft. use Section 2.
 - Buildings of 200 to 400 sq. ft. shall have a Type I footing.
 - Buildings over 400 sq. ft. shall have a Type II footing.
 - Footings shall be minimum 2,500 psi concrete with 5 x 5 - 10 x 10 welded wire mesh or crack control fiber mesh: Fibermesh @ Mesh, Inforce™ e3™ (Formerly Fibermesh MD) per manufacturer's specification may be used in lieu of wire mesh.
 - If local building codes require a minimum footing use Type II footing or the footing section required by local code. Local code governs.
 - All slabs shall be 3-1/2" (4" nominal) thick.
 - All slabs shall be in lieu of the minimum footings shown. Orange county footings shall be a minimum of 8" x 12" with (1) #5 cont. bar.
 - The notes above apply to all footing details.

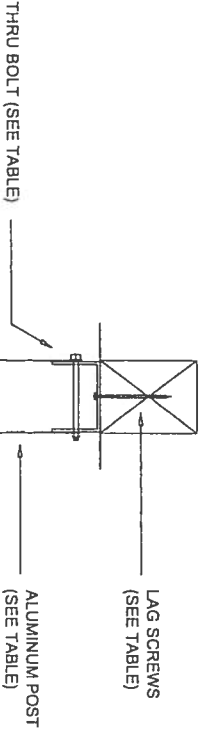

ALUMINUM U-CLIP OR ANGLE THICKNESS EQUAL TO OR GREATER THAN POST W/ MASONRY ANCHOR (SEE SECTION 9)

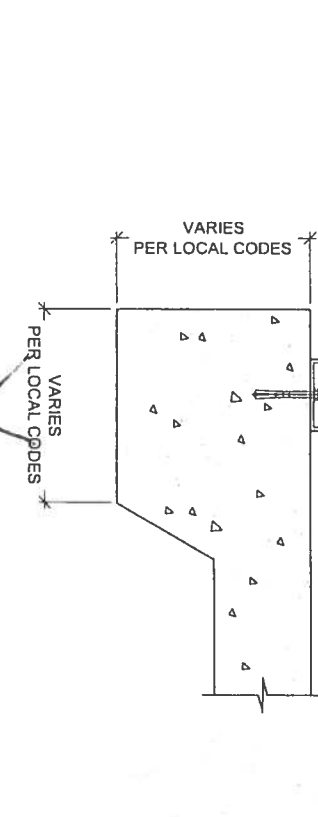

CONVENTIONAL ALUMINUM CONSTRUCTION PORCH POST CONNECTION - DETAIL 1

SCALE: 1/2" = 1'-0"

07-08-2004

Lawrence E. Bennett, P.E.
 FL # 16644
 CIVIL ENGINEER - DEVELOPMENT CONSULTANT
 P.O. BOX 214368, SOUTH DAYTONA, FL 32121
 TELEPHONE: (386) 767-4774
 FAX: (386) 767-6556

5
 SHEET

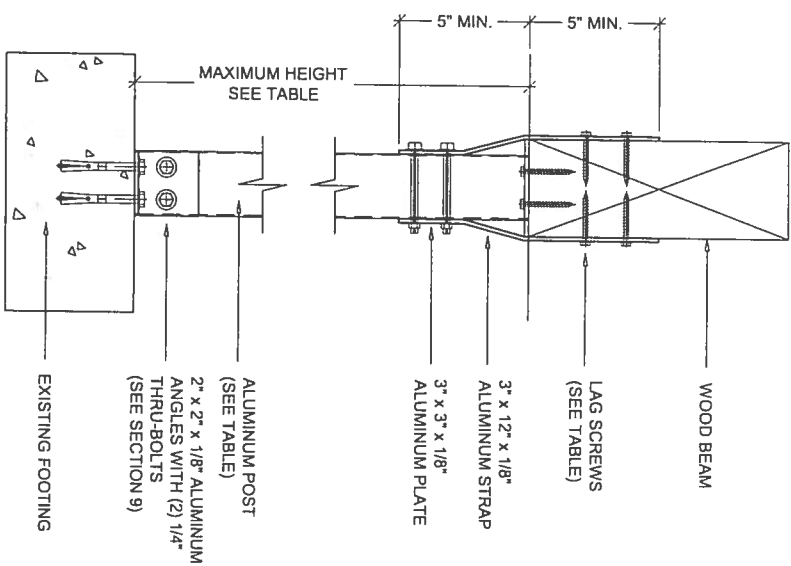

CONVENTIONAL ALUMINUM CONSTRUCTION PORCH POST CONNECTION - DETAIL 2

SCALE: 2" = 1'-0"

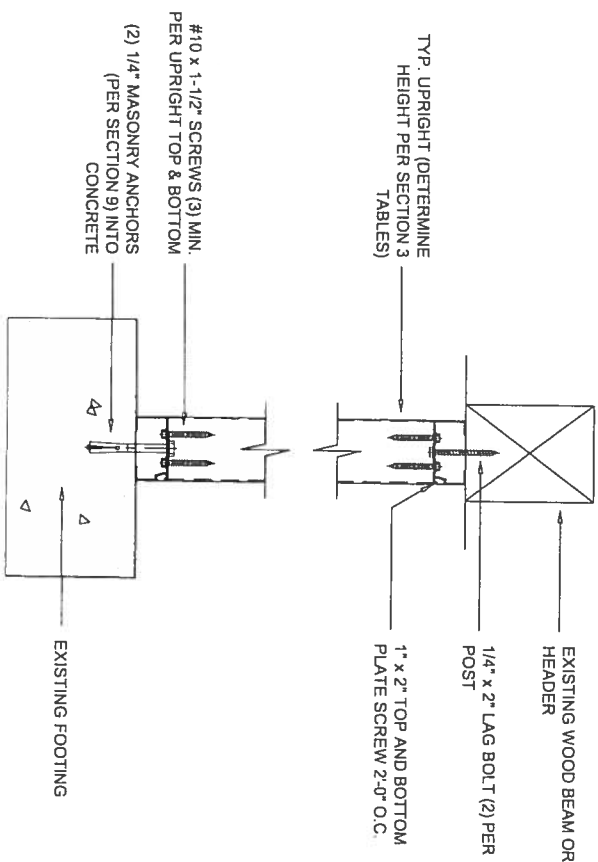

ALUMINUM SCREEN ROOM (NON LOAD BEARING) WALL UNDER WOOD FRAME PORCH

SCALE: 2" = 1'-0"

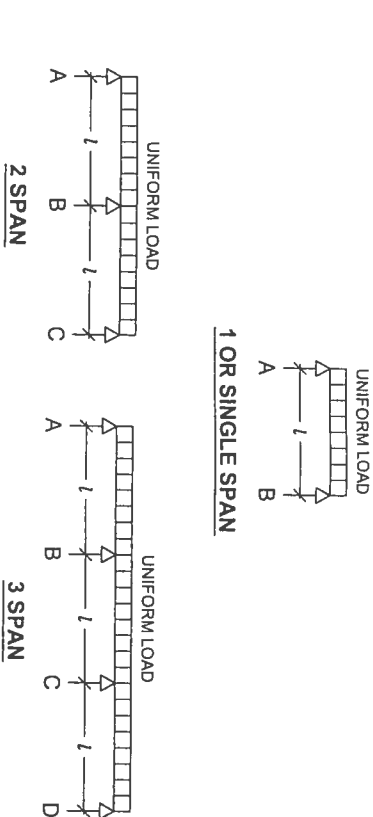

- NOTES:**
- 1) L = Span Length; α = Overhang Length
 - 2) All spans listed in the tables are for equally spaced distances between supports or anchor points.
 - 3) Hollow extrusions shall not be spliced.
 - 4) Single span girders shall only be spliced at the quarter points and splices shall be staggered.

SPAN EXAMPLES FOR GIRDERS

SCALE: N.T.S.

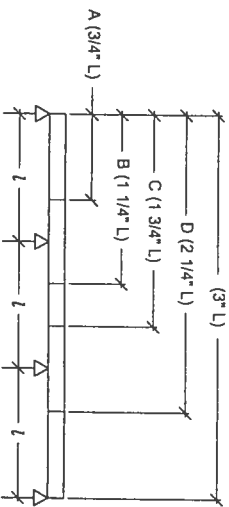

ALLOWABLE GIRDER SPLICE LOCATIONS

SCALE: N.T.S.

Table 4.1 Allowable Attributable Roof Area per Posts Supporting Conventional Construction Roofs for Enclosed or Partially Enclosed Structures
Exposure category "B", Importance factor = 1.0

| Aluminum Post | Wind Load = Applied Load = Maximum | Roof Type / Wind Zone | Light / 130 MPH 37 #/Sq. Ft. | Heavy / 140 MPH 47 #/Sq. Ft. | Tile / 150 MPH 58 #/Sq. Ft. |
|---------------|------------------------------------|---|------------------------------|------------------------------|-----------------------------|
| Height | Load (lbs.) | 3" x 3" x 0.090" Hollow Extrusion - Aluminum Alloy 6063 T-6 | 140 | 105 | 89 |
| 11'-10" | 5,184 | | 140 | 105 | 89 |
| 13'-10" | 3,888 | | 105 | 83 | 67 |
| 15'-10" | 3,024 | | 82 | 64 | 52 |
| 17'-10" | 2,268 | | 61 | 48 | 39 |
| Height | Load (lbs.) | 3" x 3" x 0.125" Hollow Extrusion - Aluminum Alloy 6063 T-6 | 187 | 147 | 119 |
| 13'-10" | 5,184 | | 140 | 110 | 89 |
| 18'-4" | 4,032 | | 109 | 86 | 70 |
| 20'-7" | 3,024 | | 82 | 64 | 52 |
| Height | Load (lbs.) | 4" x 4" x 0.125" Hollow Extrusion - Aluminum Alloy 6063 T-6 | 252 | 199 | 161 |
| 15'-9" | 9,312 | | 189 | 149 | 120 |
| 18'-5" | 6,984 | | 147 | 116 | 94 |
| 21'-0" | 5,432 | | 110 | 87 | 70 |
| 23'-8" | 4,074 | | 110 | 87 | 70 |

Notes:
Roof system design loads can be found on the roof's truss package or 47 #/SF may be assumed for a shingled roof or 58 #/SF for a tile roof.
Example: Calculate the roof area needed:
Area = A * W, where S = post spacing & W = 1/2 (projection from host structure to beam) + overhang
For S = 12(12.0') + 2.0' = R', thus, Area = 12' * 8' = 96 SF
W = 1/2(12.0') + 2.0' = R', thus, Area = 12' * 8' = 96 SF
Assume a 11'-10" post height, 140 MPH wind zone, and the house truss design package shows 47#/SF design loading. The heavy roof system column applies. There are no conversions for this table. Multiply the roof area by 47 #/SF to find the allowable load the post needs to carry. 96 SF * 47 #/SF = 4,512# Load in the "Maximum Load" column in the table above to find the post that will carry 4,512# at a height of 11'-10".

Table 4.2 Schedule of Allowable Loads / Maximum Roof Area for Anchors into wood for ENCLOSED buildings
Allowable Load / Maximum load area (Sq. Ft.) @ 120 M.P.H. wind load

| Diameter Anchor | x Embedment | Number of Anchors | 1 | 2 | 3 | 4 |
|-----------------|-------------|-------------------|-------------|--------------|--------------|--------------|
| 1/4" x 1-1/2" | 3/8" | 256#/17-SF | 528#/22-SF | 732#/33-SF | 1056#/44-SF | 1344#/56-SF |
| 1/4" x 1-1/2" | 3/8" | 396#/17-SF | 792#/33-SF | 1188#/50-SF | 1584#/66-SF | 1980#/82-SF |
| 1/4" x 1-1/2" | 3/8" | 660#/28-SF | 1320#/55-SF | 1980#/83-SF | 2640#/110-SF | 3300#/147-SF |
| 5/16" x 1-1/2" | 3/8" | 312#/13-SF | 624#/26-SF | 936#/39-SF | 1248#/52-SF | 1560#/65-SF |
| 5/16" x 1-1/2" | 3/8" | 468#/20-SF | 936#/39-SF | 1404/59-SF | 1872#/78-SF | 2340#/97-SF |
| 5/16" x 1-1/2" | 3/8" | 780#/33-SF | 1560#/65-SF | 2340/98-SF | 3120#/130-SF | 3900#/165-SF |
| 3/8" x 1-1/2" | 3/8" | 356#/15-SF | 712#/30-SF | 1068#/45-SF | 1424#/60-SF | 1780#/74-SF |
| 3/8" x 1-1/2" | 3/8" | 534#/22-SF | 1068#/45-SF | 1602#/67-SF | 2136#/90-SF | 2712#/117-SF |
| 3/8" x 2-1/2" | 3/8" | 890#/37-SF | 1780#/74-SF | 2670#/111-SF | 3560#/148-SF | 4450#/178-SF |

Anchors into concrete for ENCLOSED buildings
Allowable Load / Maximum load area (Sq. Ft.) @ 120 M.P.H. wind load

| Diameter Anchor | x Embedment | Number of Anchors | 1 | 2 | 3 | 4 |
|-----------------|-------------|-------------------|--------------|--------------|--------------|--------------|
| 1/4" x 1-1/2" | 3/8" | 757#/22-SF | 1514#/43-SF | 2271#/65-SF | 3028#/86-SF | 3785#/114-SF |
| 1/4" x 1-1/2" | 3/8" | 1057#/44-SF | 2114#/88-SF | 3171#/132-SF | 4228#/176-SF | 5285#/219-SF |
| 1/2" x 1-1/4" | 3/8" | 1433#/60-SF | 2866#/120-SF | 4299#/180-SF | 5732#/240-SF | 7165#/285-SF |

For Wind Zones/Regions other than 120 MPH (Tribas Shown), multiply allowable loads and roof areas by the conversion factor.

| WIND REGION | Applied Load | CONVERSION FACTOR | Allowable Load Conversion Multiplier | Edge Distance | Allowable Load Multiplier |
|-------------|--------------|-------------------|--------------------------------------|---------------|---------------------------|
| 100 | 19 | 1.18 | 1.27 | 12d | 1.10 |
| 110 | 23 | 1.08 | 1.18 | 11d | 1.07 |
| 120 | 27 | 1.00 | 1.00 | 10d | 1.03 |
| 130 | 29 | 0.97 | 0.98 | 9d | 1.00 |
| 140 | 32 | 0.92 | 0.98 | 8d | 0.98 |
| 150 | 37 | 0.85 | 0.95 | 7d | 0.95 |
| | 43 | 0.79 | 0.88 | 6d | 0.91 |
| | | | 0.88 | 5d | 0.88 |

Notes:
1. The minimum distance from the edge of concrete to the center of the concrete anchor and the spacing between anchors shall not be less than 9d where d is the anchor diameter.
2. Concrete screws are limited to 2" embedment by manufacturers.
3. Values listed are allowed loads with a safety factor of 4 applied.
4. Products equal to raw may be substituted.
5. Anchors receiving loads perpendicular to the diameter are in tension.
6. Anchors receiving loads parallel to the diameter are shear loads.
Example: Determine the number of concrete anchors required by dividing the uplift load by the anchor allowed load.
For a 2" x 6" beam with spacing = 7'-0" O.C.; allowed span = 25'-9" (Table 1.1)
UPLIFT LOAD = 12(BEAM SPAN) x BEAM x UPRIGHT SPACING
NUMBER OF ANCHORS = 630.875# / 300# = 2.102
Therefore, use 2 anchors, one (1) on each side of upright.
Table is based on Raw Products allowable loads for 2,500 p.s.i. concrete

Table 4.3 Allowable Header Spans for Bearing Walls Headers Constructed of #2 Grade Non-dense Pine w/ or w/o Pressure Treatment w/ 1/2" Plywood Spacer Supporting Aluminum Roof System Loads Only

| Roof Span | 180 M.P.H. / 22 #/Sq. Ft. | | | | 130 M.P.H. / 37 #/Sq. Ft. | | | | 150 M.P.H. / 50 #/Sq. Ft. | | | | |
|-----------|---------------------------|---------|--------|---------|---------------------------|---------|---------|---------|---------------------------|--------|---------|---------|--------|
| | (2) N | (2) N | (2) N | (2) N | (2) N | (2) N | (2) N | (2) N | (2) N | (2) N | (2) N | (2) N | (2) N |
| 2 | 15'-2" | 18'-8" | 22'-3" | 25'-8" | 14'-5" | 17'-9" | 21'-6" | 24'-10" | 13'-10" | 17'-0" | 20'-10" | 23'-3" | 26'-7" |
| 6 | 10'-6" | 12'-11" | 15'-5" | 17'-9" | 9'-11" | 12'-11" | 14'-11" | 17'-3" | 8'-11" | 11'-5" | 14'-5" | 16'-10" | 19'-2" |
| 10 | 8'-11" | 10'-11" | 13'-0" | 15'-0" | 8'-5" | 10'-5" | 12'-7" | 14'-6" | 8'-1" | 10'-1" | 12'-2" | 14'-2" | 16'-2" |
| 14 | 7'-11" | 9'-9" | 11'-8" | 13'-4" | 7'-6" | 9'-4" | 11'-3" | 12'-11" | 7'-3" | 9'-0" | 10'-11" | 12'-8" | 14'-5" |
| 18 | 7'-4" | 8'-11" | 10'-9" | 12'-4" | 6'-11" | 8'-7" | 10'-4" | 11'-11" | 6'-8" | 8'-3" | 10'-0" | 11'-8" | 13'-5" |
| 22 | 6'-10" | 8'-5" | 10'-0" | 11'-6" | 6'-6" | 8'-1" | 9'-8" | 11'-2" | 6'-2" | 7'-8" | 9'-4" | 10'-11" | 12'-8" |
| 26 | 6'-5" | 7'-11" | 9'-6" | 10'-11" | 6'-1" | 7'-7" | 9'-2" | 10'-2" | 5'-10" | 7'-4" | 8'-10" | 10'-4" | 12'-1" |
| 30 | 6'-2" | 7'-7" | 9'-0" | 10'-5" | 5'-10" | 7'-3" | 8'-8" | 10'-1" | 5'-7" | 7'-1" | 8'-5" | 10'-0" | 11'-7" |
| 32 | 6'-0" | 7'-5" | 8'-10" | 10'-2" | 5'-9" | 7'-1" | 8'-6" | 9'-10" | 5'-6" | 7'-0" | 8'-3" | 9'-7" | 10'-4" |

Notes:
1. N.J. is the required number of jack studs. If the number of jack studs is (1) then the header may be supported by a Serrco or equal joist buckler. Jack studs are assumed to be #2 spruce pine or fir.
2. Use 110 M.P.H. / 27 #/Sq. Ft. for wind design speeds less than 110 M.P.H.
3. Applied load includes 2# / Sq. Ft. dead load.
4. Building width is measured perpendicular to the ridge. For widths between those shown, spans may be interpolated.
5. Spans may be interpolated.

Table 4.4 Allowable Floor Joist Spans for Decks and Floors Joists Constructed of #2 Grade Non-dense Pine w/ or w/o Pressure Treatment

| Joist Spacing | 1 & 2 Span | | | 3 Span | | | 1 & 2 Span | | | 3 Span | | | |
|---------------|-------------|-------------|-------------|-------------|-------------|-------------|-------------|-------------|-------------|-------------|-------------|-------------|--------|
| | 45#/sq. ft. | 45#/sq. ft. | 55#/sq. ft. | 45#/sq. ft. | 45#/sq. ft. | 55#/sq. ft. | 45#/sq. ft. | 45#/sq. ft. | 55#/sq. ft. | 45#/sq. ft. | 45#/sq. ft. | 55#/sq. ft. | |
| 12" | 10'-2" | 13'-4" | 16'-11" | 20'-0" | 12'-6" | 16'-2" | 19'-2" | 9'-6" | 12'-6" | 15'-10" | 18'-2" | 11'-9" | 15'-5" |
| 16" | 9'-3" | 12'-2" | 15'-5" | 18'-8" | 10'-11" | 14'-1" | 16'-9" | 8'-8" | 11'-5" | 14'-6" | 17'-7" | 10'-9" | 13'-6" |
| 24" | 8'-1" | 10'-8" | 13'-7" | 15'-10" | 8'-11" | 11'-7" | 13'-9" | 7'-7" | 9'-11" | 12'-9" | 15'-5" | 8'-11" | 11'-7" |

Notes:
1. Applied load includes 5# / Sq. Ft. dead load for deck. Joist weight is also considered as part of finishing span.
2. Joist shall be lapped over support and nailed together. Splicing of joist shall not be allowed.
3. The above tables have been restricted to the maximum length of p.i.p. available which is 20'-0".

Table 4.5.1 Allowable Floor or Deck Girder Spans Girders Constructed of One (1) #2 Grade Non-dense Pressure Treated Pine Supporting Floor Dead Loads and Live Loads

| Load Width Perpendicular to Girder | Applied Load 55 #/sq. ft. | | | | | | | |
|------------------------------------|---------------------------|---------|----------|----------|---------|---------|----------|----------|
| | 1 & 2 Span | 2" x 8" | 2" x 10" | 2" x 12" | 2" x 6" | 2" x 8" | 2" x 10" | 2" x 12" |
| 4'-0" | 5'-4" | 7'-10" | 8'-2" | 9'-7" | 5'-11" | 8'-9" | 9'-2" | 10'-8" |
| 6'-0" | 4'-4" | 6'-5" | 6'-8" | 7'-10" | 4'-10" | 7'-2" | 7'-6" | 8'-9" |
| 8'-0" | 3'-9" | 5'-7" | 5'-10" | 6'-10" | 4'-3" | 6'-2" | 6'-6" | 7'-7" |

Table 4.5.2 Allowable Floor or Front / FORTH Wall Deck Girder Spans Girders Constructed of Two (2) #2 Grade Non-dense Pressure Treated Pine With 1/2" Plywood Spacer Supporting Floor Dead Loads and Live Loads

| Load Width Perpendicular to Girders | Applied Load 67 #/sq. ft. | | | | | | | | | | | |
|-------------------------------------|---------------------------|--------|--------|--------|--------|-------|--------|-------|-------|--------|-------|-------|
| | 1 & 2 Span | | | 3 Span | | | 4 Span | | | 5 Span | | |
| 6'-0" | 6'-7" | 8'-8" | 10'-0" | 10'-0" | 6'-8" | 6'-8" | 6'-8" | 6'-8" | 5'-0" | 5'-0" | 5'-0" | 5'-0" |
| 8'-0" | 5'-11" | 7'-10" | 9'-3" | 10'-0" | 6'-8" | 6'-8" | 6'-8" | 6'-8" | 5'-0" | 5'-0" | 5'-0" | 5'-0" |
| 10'-0" | 5'-3" | 7'-4" | 8'-1" | 9'-5" | 5'-10" | 6'-8" | 6'-8" | 6'-8" | 5'-0" | 5'-0" | 5'-0" | 5'-0" |
| 12'-0" | 4'-8" | 6'-10" | 7'-2" | 8'-5" | 5'-3" | 6'-8" | 6'-8" | 6'-8" | 5'-0" | 5'-0" | 5'-0" | 5'-0" |
| 14'-0" | 4'-3" | 6'-3" | 6'-7" | 7'-8" | 4'-9" | 6'-8" | 6'-8" | 6'-8" | 4'-7" | 5'-0" | 5'-0" | 5'-0" |

Notes:
1. Applied load includes a 10 #/sq. ft. dead load for flooring and joist. Girder weight is also considered in limiting girder spans.
2. Splicing of girders shall be @ 1/3 span points only and all splices shall be staggered.
3. Spans between supports shall be equal.
4. Overhangs of girders shall be limited to 2'-6".
5. The above tables have been restricted to reflect the maximum length of p.i.p. available which is 20'-0". Therefore, single girder spans are restricted to 10'-0" triple to 6'-8" and four span to 5'-0".
6. Spans may be interpolated.

Table 4.6 Maximum Stud Wall Height for Various Wind Loads, Stud Spacing, and Species of Lumber For Residential Construction; Enclosed or Partially Enclosed Buildings

| Stud Spacing | Wind Velocity 100 MPH, Applied Load = 17 #/SF | | | Wind Velocity 110 MPH, Applied Load = 20 #/SF | | | Wind Velocity 120 MPH, Applied Load = 24 #/SF | | | Wind Velocity 130 MPH, Applied Load = 28 #/SF | | | Wind Velocity 140 MPH, Applied Load = 33 #/SF | | | Wind Velocity 150 MPH, Applied Load = 38 #/SF | | |
|--------------|---|-----------------------------|-----------------------------|---|-----------------------------|-----------------------------|---|-----------------------------|-----------------------------|---|-----------------------------|-----------------------------|---|-----------------------------|-----------------------------|---|-----------------------------|-----------------------------|
| | 2 x 4 S.P.F. 12 x 4 #2 Pine | 2 x 6 S.P.F. 12 x 6 #2 Pine | 2 x 8 S.P.F. 12 x 8 #2 Pine | 2 x 4 S.P.F. 12 x 4 #2 Pine | 2 x 6 S.P.F. 12 x 6 #2 Pine | 2 x 8 S.P.F. 12 x 8 #2 Pine | 2 x 4 S.P.F. 12 x 4 #2 Pine | 2 x 6 S.P.F. 12 x 6 #2 Pine | 2 x 8 S.P.F. 12 x 8 #2 Pine | 2 x 4 S.P.F. 12 x 4 #2 Pine | 2 x 6 S.P.F. 12 x 6 #2 Pine | 2 x 8 S.P.F. 12 x 8 #2 Pine | 2 x 4 S.P.F. 12 x 4 #2 Pine | 2 x 6 S.P.F. 12 x 6 #2 Pine | 2 x 8 S.P.F. 12 x 8 #2 Pine | 2 x 4 S.P.F. 12 x 4 #2 Pine | 2 x 6 S.P.F. 12 x 6 #2 Pine | 2 x 8 S.P.F. 12 x 8 #2 Pine |
| 12" | 10'-0" | 10'-0" | 17'-0" | 17'-0" | 10'-0" | 10'-0" | 15'-6" | 15'-6" | 10'-0" | 10'-0" | 13'-7" | 13'-7" | 15'-0" | 15'-0" | 10'-0" | 10'-0" | 13'-3" | 13'-3" |
| 16" | 9'-4" | 10'-0" | 14'-9" | 17'-2" | 8'-8" | 10'-0" | 13'-7" | 13'-7" | 10'-0" | 10'-0" | 11'-1" | 11'-1" | 13'-10" | 13'-10" | 10'-8" | 10'-8" | 12'-11" | 12'-11" |
| 24" | 7'-8" | 8'-11" | 12'-0" | 14'-0" | 7'-0" | 8'-2" | 11'-1" | 11'-1" | 6'-10" | 6'-10" | 9'-2" | 9'-2" | 10'-8" | 10'-8" | 8'-2" | 8'-2" | 10'-8" | 10'-8" |

Notes:
1. Applied load values based on ASCE 7-98 Table 6-2
2. Wood design values are based on #2 S.P.F. (South) and Southern Pine construction grade wood from NDS American Forest & Paper Association, current edition.
3. For 'C' wind exposure category, multiply allowable stud heights by 0.85.
4. For utility sheds multiply heights by 1.14. For utility sheds in exposure 'C' category wind zones, multiply allowable height by 0.97.
5. Stud heights are limited by code and 2 x 4 greater than 10'-0" (stud length) are not shown. 2 x 6 greater than 18'-0" (stud length) are not shown. Maximum stud heights less than 6'-6" are not listed.

Lawrence E. Bennett, P.E.
FL # 16644
CIVIL ENGINEER - DEVELOPMENT CONSULTANT
P.O. BOX 214368, SOUTH DAYTONA, FL 32121
TELEPHONE: (386) 767-4774
FAX: (386) 767-6556

DATE: 01/20/06
SHEET: 7 OF 8

General Notes and Specifications:

- The following attachments are designed to be married to block and wood frame structures of adequate structural capacity. The contractor / home owner shall verify that the host structure is in good condition and of sufficient strength to hold the proposed addition.
- If there is a question about the host structure, the owner (at his own expense) shall hire an architect, engineer, or a certified home inspection company to verify host structure capacity.
- Roll formed roof panels (pans) are designed for uniform loads and can not be walked on unless plywood is laid across the ribs. Pans have been tested and perform better in wind uplift loads than dead load + live loads. Spans for pans are based on deflection of L/80 for high wind zone criteria.
- Composite panels can be loaded as walk on or uniform loads and have, when tested performed well in either test. The composite panel tables are based on bending properties determined at a deflection limit of L/180.
- The following rules apply to attachments involving mobile and manufactured homes:
 - Structures to be placed adjacent to a mobile / manufactured home built prior to 1994 shall use "fourth wall construction" or shall provide detailed plans of the mobile / manufactured home along with addition plans for site specific review and seal by the engineer. This applies to all screen / glass rooms, and / or other structures to be attached.
 - For mobile / manufactured homes built after 1994, structures may be attached provided the project follows the plan for attachment of this manual. The contractor / home owner shall provide verification of the structural system used to build the host structure.
- The shapes and capacities of pans and composite panels are from "Industry Standard" shapes, except for manufacturers proprietary shapes. Unless the manufacturer of the product is known, use the "Industry Standard" Tables for allowable spans.
- When converting a screen room to a glass room or a carport to a garage, the roof must be checked and reinforced for the enclosed building requirements.
- When using TEK screws in lieu of S.M.S., longer screws must be used to compensate for drill head.
- For high velocity hurricane zones the minimum live load / applied load shall be 30 PSF.
- Interior walls & ceilings of composite panels may have 1/2" sheet rock added by securing the sheet rock w/ 1" fine thread sheet rock screws at 16" O.C. each way.
- All fascia guller and caps shall have water relief ports.
- Spans may be interpolated between values but not extrapolated outside values.
- Design Check List and Inspection Guides for Solid Roof Panel Systems are included in inspection guides for sections 2, 3A & B, 4 & 5. Use section 2 inspection guide for solid roof in section 1.
- All exposed screw heads through roof panels into the roof sub structure shall be caulked w/ silicon sealant.

Section 7 Design Statement:

The roof systems designed for section 7 are Main Wind Force Resisting Systems and Components and Cladding. In conformance with the 2004 Florida Building Code such systems must be designed using loads for components & cladding. Thus, Section 7 uses several different categories of these loads as described below. All pressures shown in the table below are in PSF (#/SF).

- Free-standing Structures with Mono-sloped Roofs** with a minimum live load of 10 PSF except for 140B and 150 MPH loads which are 30 PSF. The design wind loads used are from ASCE 7-98 Section 6.5, Analytical Procedure. The loads assume a mean roof height of less than 30', roof slope of 0° to 10°, $I = 0.77$ for open structures & 1.00 for all others. Negative internal pressure coefficient is 0.18 for enclosed and 0.55 for partially enclosed structures.
- Attached Covers** such as carports, patio covers, gabled carports, and screen rooms with a minimum live load of 10 PSF except for 140B and 150 MPH loads which are 30 PSF. The design wind loads used are from ASCE 7-98 Section 6.5, Analytical Procedure. Roof slope of 0° to 25° (+/-, 10°); $I = 1.00$. Negative internal pressure coefficient is 0.18 for enclosed and 0.55 for partially enclosed structures.
- Glass & Modular Rooms** design loads use a minimum live load of 20 PSF and wind loads are from ASCE 7-98 Section 6.5, Analytical Procedure and the 2004 Florida Building Code. The loads assume a mean roof height of less than 30', roof slope of 20° to 30° (+/-, 10°); $I = 1.00$.
- Enclosed structural systems** use a negative internal pressure coefficient = +/- 0.18.
- Partially Enclosed structural systems** use a negative internal pressure coefficient = +/- 0.55.
- Overhangs** use a minimum live load of 20 PSF except for 140B and 150 MPH loads which are 30 PSF. Wind loads are from ASCE 7-98 Section 6.5, Analytical Procedure for Components & Cladding for Enclosed or Partially Enclosed Structural Systems. The loads assume a mean roof height of less than 30', roof slope of 20° to 30° (+/-, 10°); $I = 1.0$. Negative internal pressure coefficient is 0.18 for enclosed and 0.55 for partially enclosed structures.
- Anchors** for composite panel roof systems were computed on a load width of 10' and 16' projection with a 2' overhang. Any greater load width shall be site specific.

Conversion Table 7A

Lead Conversion Factors Based on Mean Roof Height of Host Structure For All Components Exposure "B" to "C"

| Mean Host Structure Height | Pans | Composite Panels |
|----------------------------|------|------------------|
| 0 - 15' | 0.91 | 0.94 |
| 15 - 20' | 0.88 | 0.92 |
| 20 - 25' | 0.86 | 0.91 |
| 25 - 30' | 0.85 | 0.89 |

Conversion Table 7B

Conversion Based on Mean Height of Host Structure for Solid Roof Systems From Exposure "B" to "C"

| Mean Host Structure Height | Load Multiplier | Pans | Composite Panels |
|----------------------------|-----------------|------|------------------|
| 0 - 15' | 1.21 | 0.94 | 0.91 |
| 15 - 20' | 1.29 | 0.92 | 0.88 |
| 20 - 25' | 1.34 | 0.91 | 0.86 |
| 25 - 30' | 1.40 | 0.89 | 0.85 |

INDUSTRY STANDARD ROOF PANELS

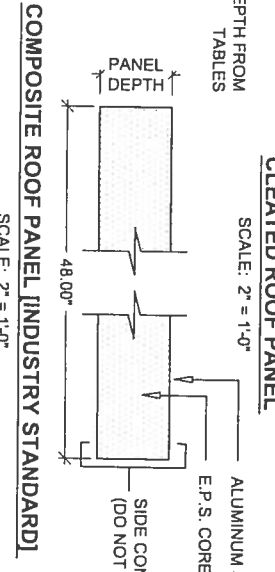
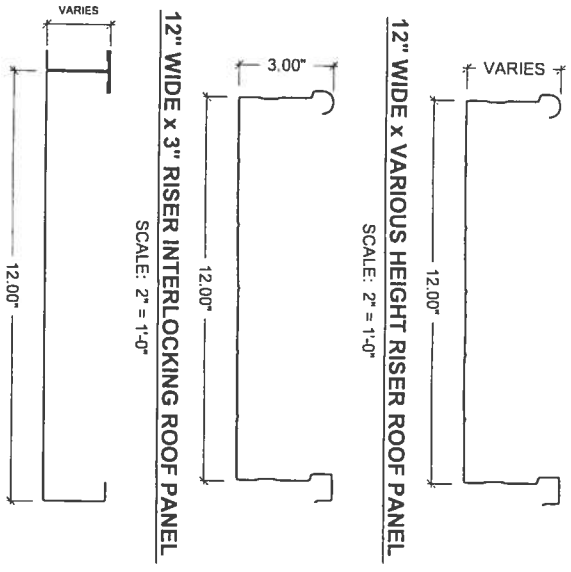

PAN ROOF ANCHORING DETAILS

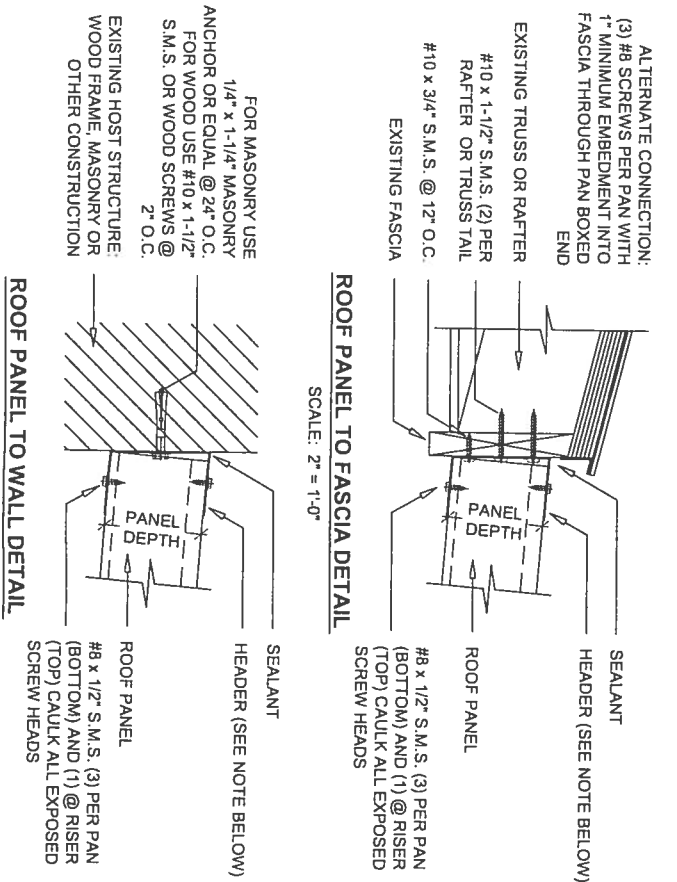

ALTERNATE MOBILE HOME FLASHING FOR FOURTH WALL CONSTRUCTION PAN ROOF PANELS

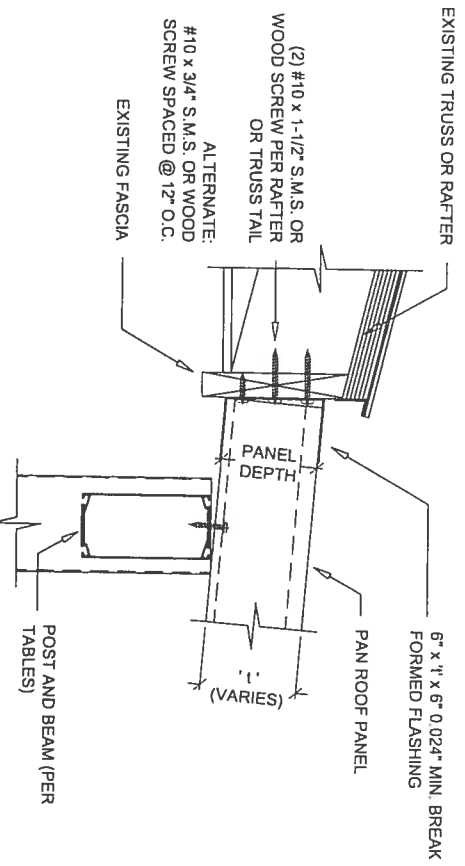

COMPOSITE ROOF ANCHORING DETAILS

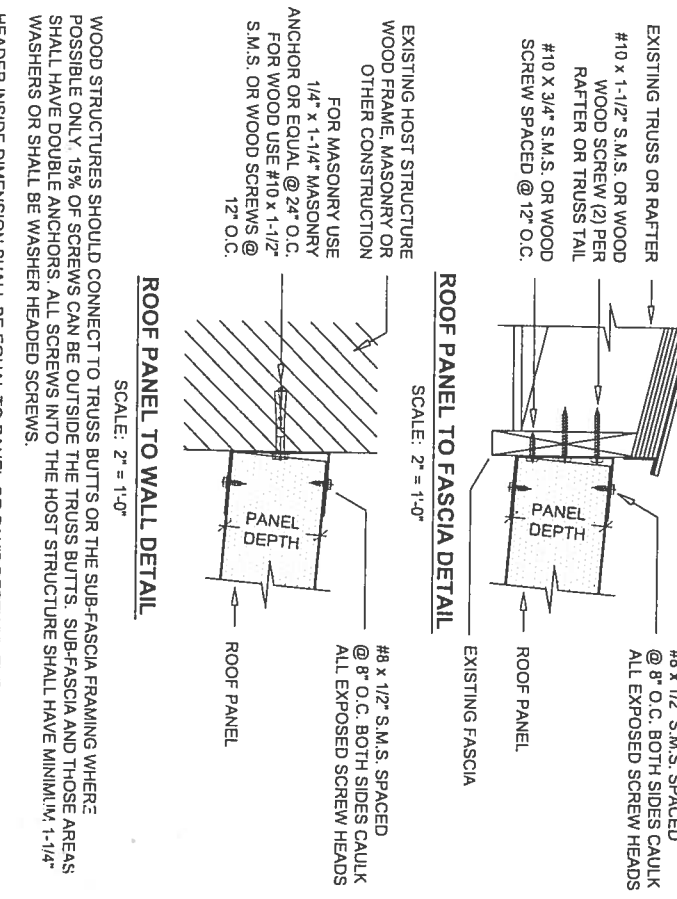

ROOF PANELS SHALL BE ATTACHED TO THE HEADER WITH (3) EACH #8 x 1/2" LONG CORROSION RESISTANT SHEET METAL SCREWS WITH 1/2" WASHERS. ALL SCREW HEADS SHALL BE CAULKED OR SHALL HAVE NEOPRENE GASKET BETWEEN THE WASHER AND THE PAN. PAN RISERS SHALL RECEIVE (1) EACH #8 x 1/2" SCREW EACH. THE PANS MAY BE ANCHORED THROUGH BOXED PAN WITH (3) EACH #8 x 1" OF THE ABOVE SCREW. TYPES AND THE ABOVE SPECIFIED RIZER SCREW, #8 x 9/16" TEK SCREWS ARE ALLOWED AS A SUBSTITUTE FOR #8 x 1/2" S.M.S.

| 100 - 123 #8 | 130 #10 | 140 #12 | 150 #12 |
|--------------|---------|---------|---------|
|--------------|---------|---------|---------|

STRUCTURES WITH WOOD FRAME WALLS & ALUMINUM ROOF SYSTEMS
ALUMINUM STRUCTURES DESIGN MANUAL
2004 FLORIDA BUILDING CODE
MAY 2004 EDITION
SECTION 7 DETAILS

Lawrence E. Bennett, P.E.
FL # 16644
CIVIL ENGINEER - DEVELOPMENT CONSULTANT
P.O. BOX 214368, SOUTH DAYTONA, FL 32121
TELEPHONE: (386) 767-4774
FAX: (386) 767-6556

SEAL
DATE 01 2005
8A
OF 8

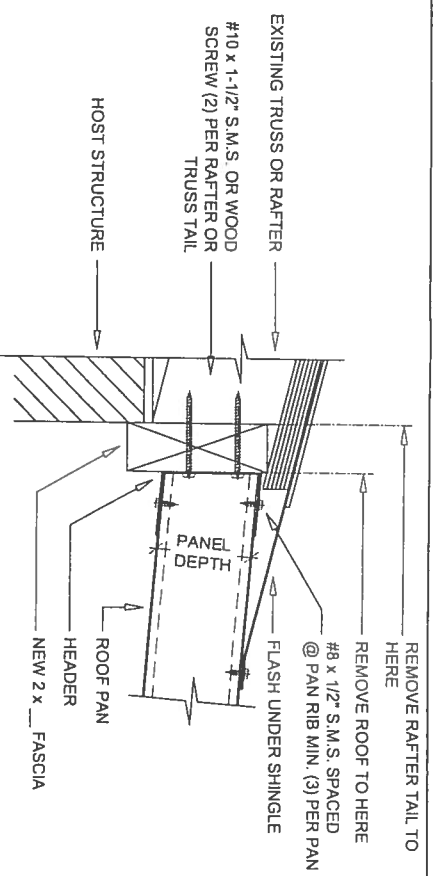

REMOVED RAFTER TAIL ROOF PAN TO FASCIA DETAIL

SCALE: 2" = 1'-0"

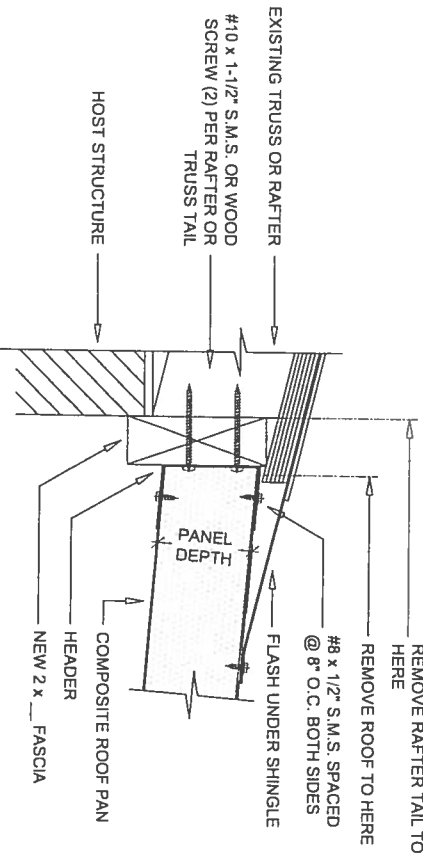

REMOVED RAFTER TAIL COMPOSITE ROOF PANEL TO WALL DETAIL

SCALE: 2" = 1'-0"

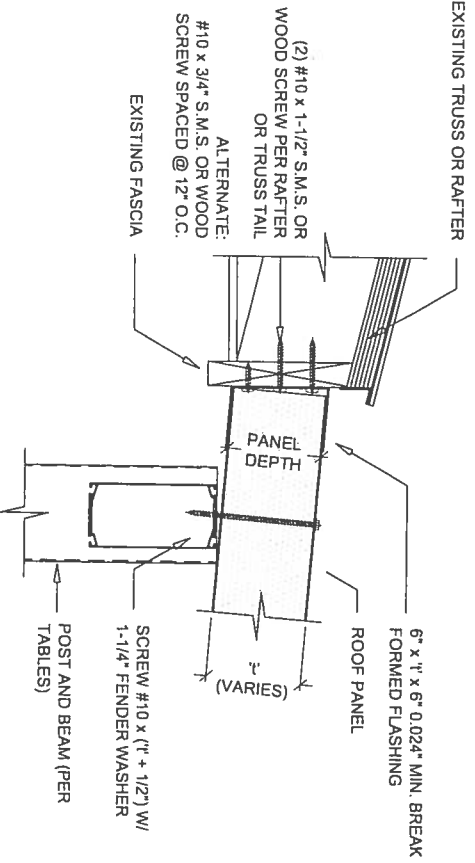

ALTERNATE MOBILE HOME FLASHING FOR FOURTH WALL CONSTRUCTION COMPOSITE ROOF PANELS

SCALE: 2" = 1'-0"

- INSTALLATION INSTRUCTIONS:**
- PLACE (2) BEADS OF CAULKING ON BACK SIDE OF HEADER BEFORE INSTALLING.
 - SLIDE 1" TAB AT TOP OF HEADER UNDER DRIP EDGE. DO NOT PUSH DRIP EDGE UP. DRIP EDGE MUST MAINTAIN SAME PLANE AS SLOPE OF ROOF.
 - FASTEN HEADER TO FASCIA BOARD WITH #10 x 1" SCREWS @ 6" O.C. STAGGERED TOP AND BOTTOM (SEE DETAIL ABOVE)
 - PLACE COMPOSITE ROOF PANEL INTO HEADER AND ATTACH TO 4TH WALL POST AND BEAM SYSTEM ONLY. DO NOT ATTACH TO HEADER. HEADER IS USED AS FLASHING ONLY.

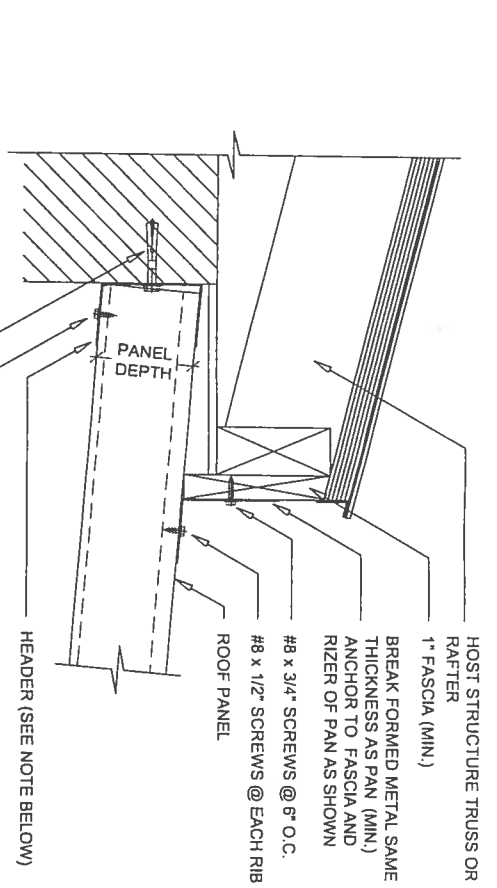

ALTERNATE ROOF PANEL TO WALL DETAIL

SCALE: 2" = 1'-0"

ROOF PANELS SHALL BE ATTACHED TO THE HEADER W/ (3) EACH #8 x 1/2" LONG CORROSION RESISTANT S.M.S. W/ 1/2" WASHERS. ALL SCREW HEADS SHALL BE CAULKED OR SHALL HAVE NEOPRENE GASKET BETWEEN THE WASHER AND THE PAN. PAN RIBS SHALL RECEIVE (1) EACH #8 x 1/2" SCREW EACH. THE PANS MAY BE ANCHORED THROUGH BOXED PAN W/ (3) EACH #8 x 1" OF THE ABOVE SCREW TYPES AND THE ABOVE SPECIFIED RIB SCREW.

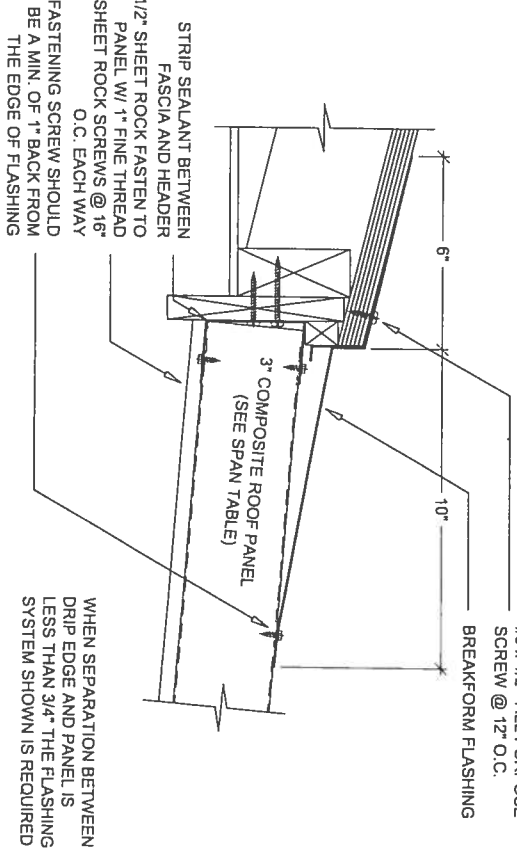

ALTERNATE DETAIL FOR FLASHING ON SHINGLE ROOFS

SCALE: 2" = 1'-0"

- NOTES:**
- FLASHING TO BE INSTALLED A MIN. 6" UNDER THE FIRST ROW OF SHINGLES.
 - STANDARD COIL FOR FLASHING IS .16" .019 MIL. COIL.
 - FIRST ROW OF EXISTING NAILS MUST BE REMOVED TO INSTALL FLASHING PROPERLY.
 - FLASHING WILL BE INSTALLED UNDER THE FELT PAPER WHEN POSSIBLE.
 - HEADER WILL BE PUTTY TAPED AND CAULKED EVEN THOUGH FLASHING IS TO BE INSTALLED.
 - IF THE DROP FROM THE EDGE OF THE SHINGLE DOWN TO THE TOP OF THE HEADER IS MORE THAN 1" THEN THE DRIP EDGE WILL HAVE TO BE BROKEN TO CONFORM TO THIS DROP.
 - WHEN USING FLASHING THE SMALLEST SIZE HEADER AVAILABLE SHOULD BE USED. 12" O3 MIL. ROLLFORM OR 8" BREAKFORM IS BEST SUITED FOR HEADER SINCE IT KEEPS THE FLAP LIP OF THE HEADER BACK FROM THE EDGE OF THE FLASHING.
 - WHEN SEPARATION BETWEEN DRIP EDGE AND PANEL FLASHING IS REQUIRED 1/2" SEPARATION MINIMUM.
 - STRIP SEALANT BETWEEN FASCIA AND HEADER PRIOR TO INSTALLATION.

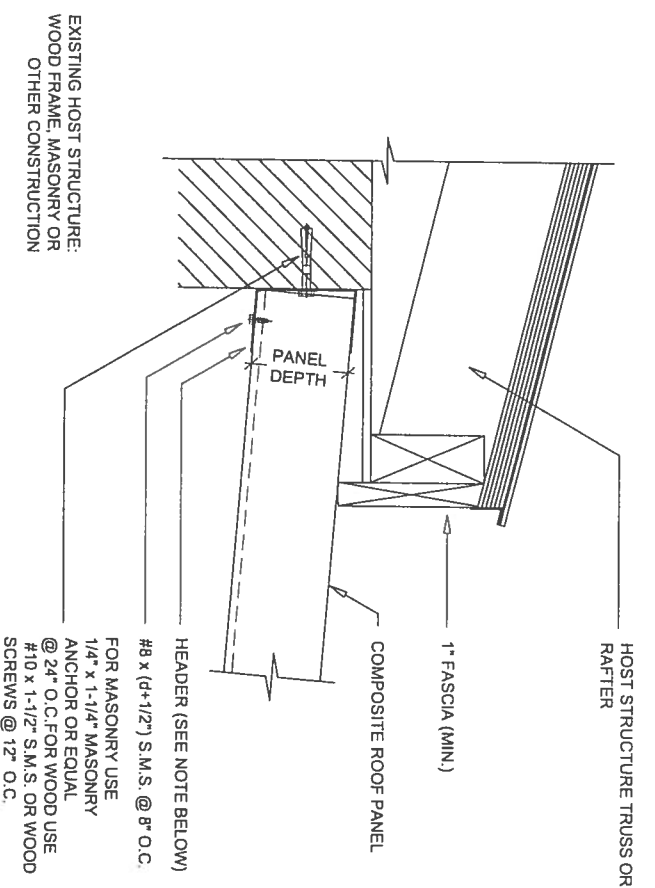

ALTERNATE COMPOSITE ROOF PANEL TO WALL DETAIL

SCALE: 2" = 1'-0"

COMPOSITE ROOF PANELS SHALL BE ATTACHED TO EXTRUDED HEADER W/ (3) EACH #8 x (d+1/2") LONG CORROSION RESISTANT S.M.S.

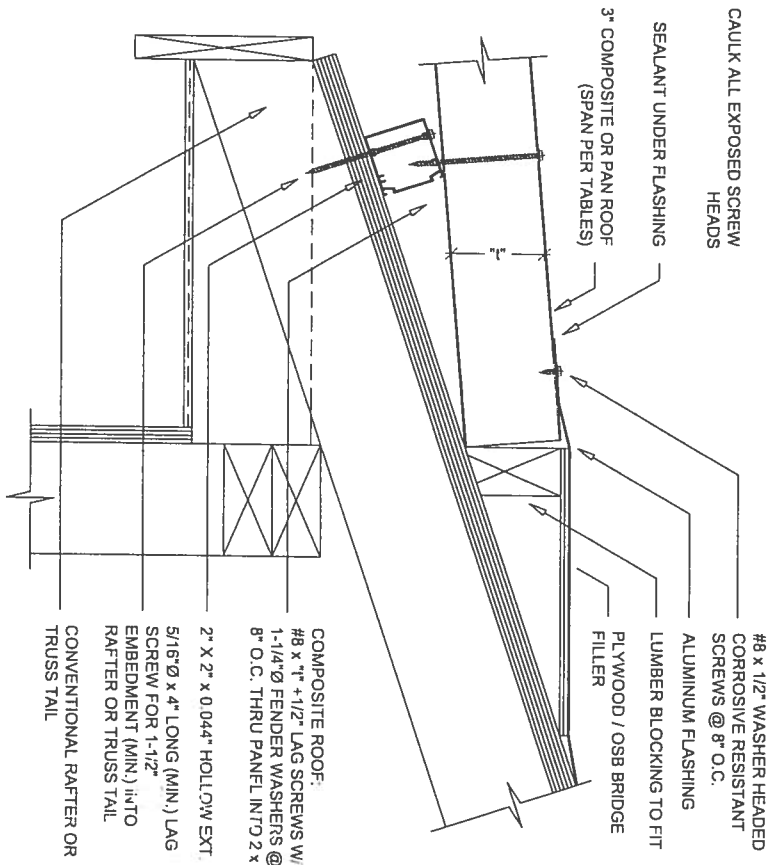

WEDGE ROOF CONNECTION DETAIL

SCALE: 2" = 1'-0"

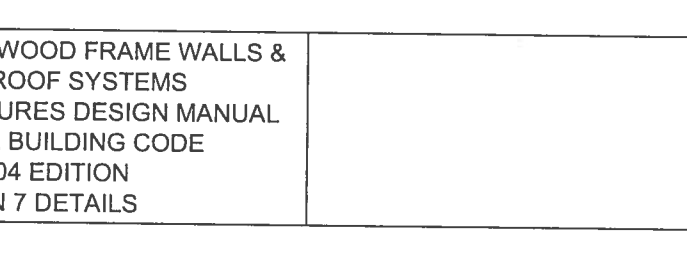
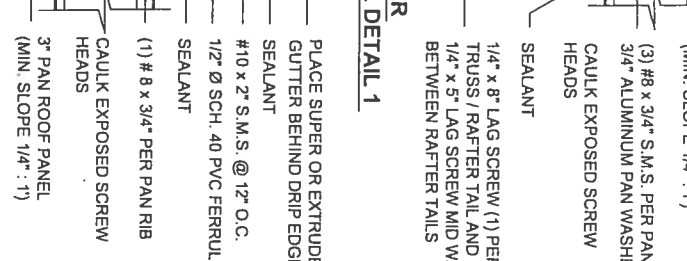
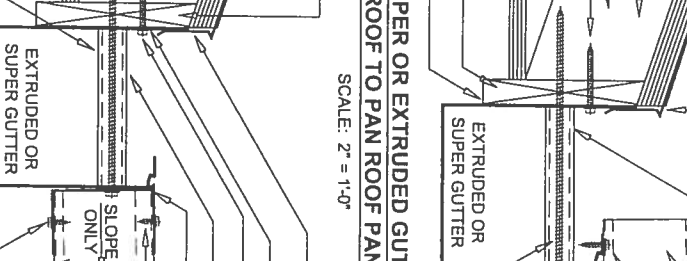
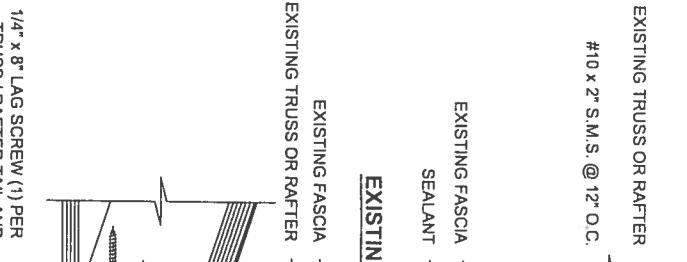
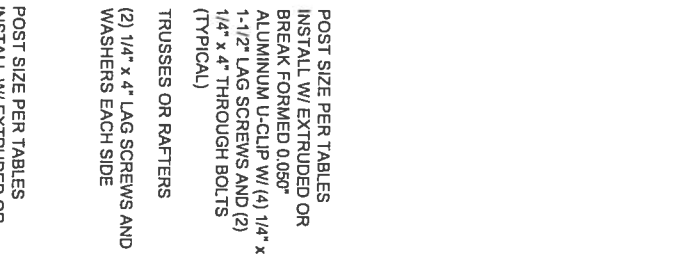
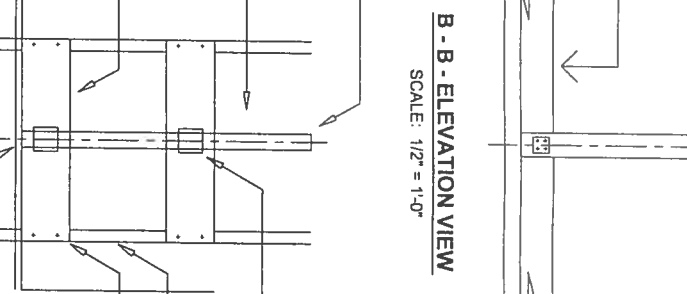
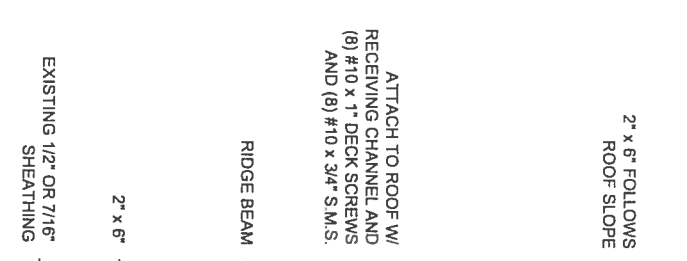
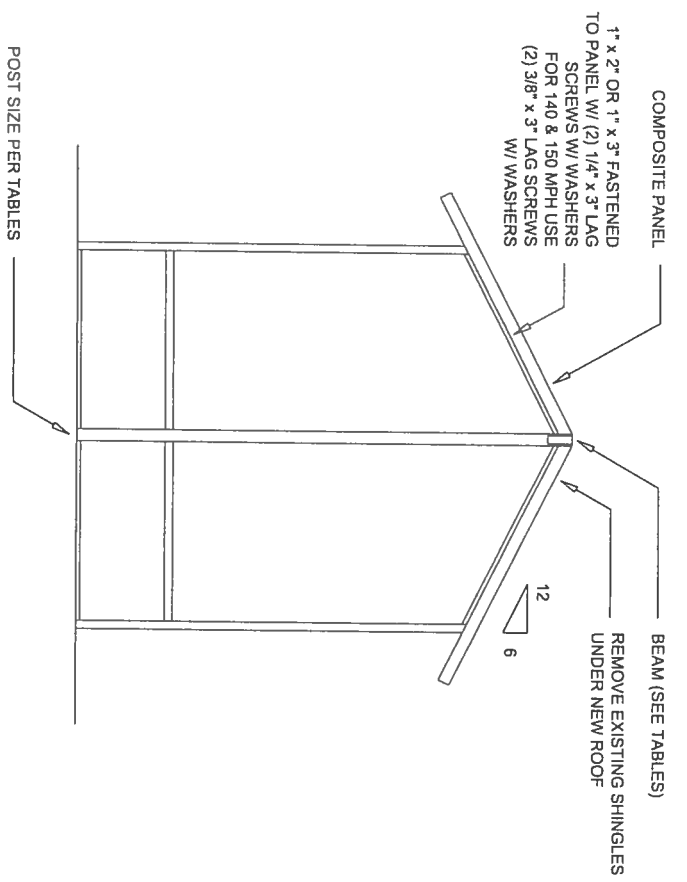

SCREEN OR SOLID WALL ROOM VALLEY CONNECTION FRONT WALL ELEVATION VIEW
SCALE: 1/4" = 1'-0"

B - B - ELEVATION VIEW
SCALE: 1/2" = 1'-0"

EXISTING ROOF TO PAN ROOF PANEL DETAIL 1
SCALE: 2" = 1'-0"

EXISTING ROOF TO PAN ROOF PANEL DETAIL 2
SCALE: 2" = 1'-0"

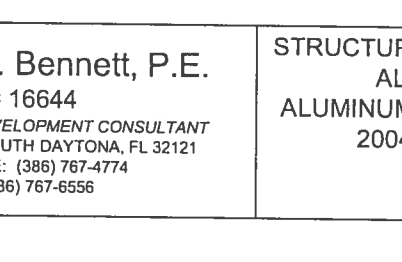
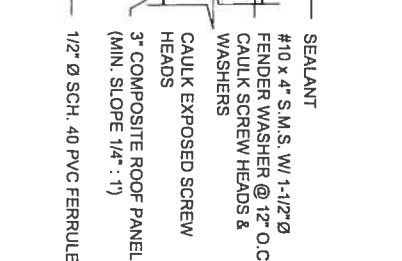
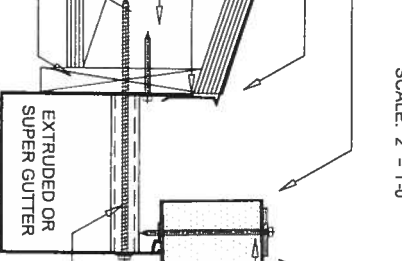
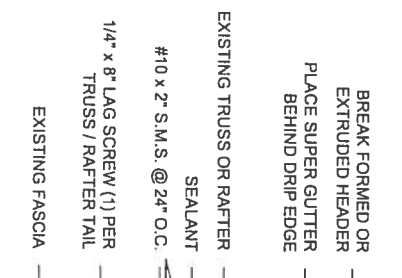
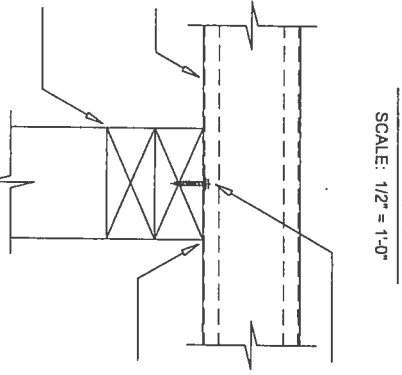
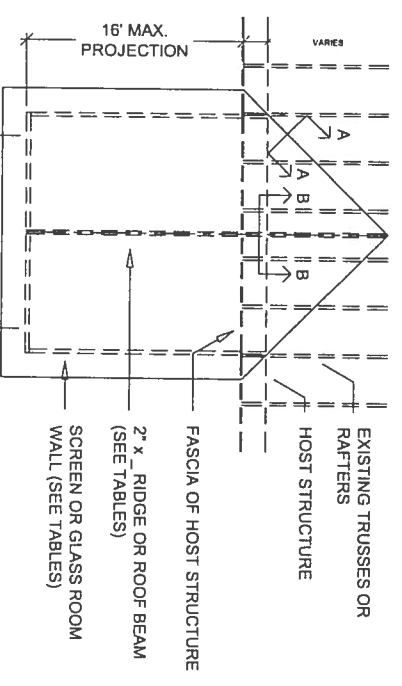

SCREEN OR SOLID WALL ROOM VALLEY CONNECTION PLAN VIEW
SCALE: 1/8" = 1'-0"

B - B - PLAN VIEW
SCALE: 1/2" = 1'-0"

EXISTING ROOF TO COMPOSITE ROOF PANEL DETAIL 1
SCALE: 2" = 1'-0"

EXISTING ROOF TO COMPOSITE ROOF PANEL DETAIL 2
SCALE: 2" = 1'-0"

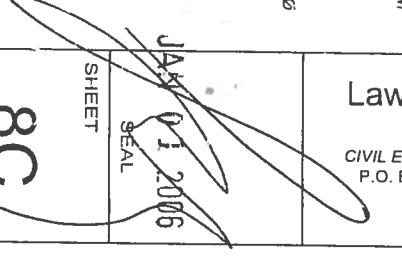
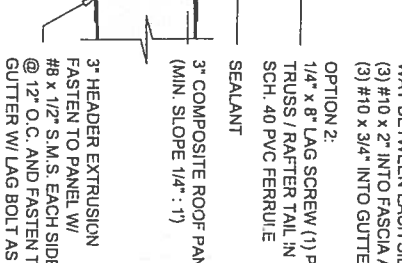
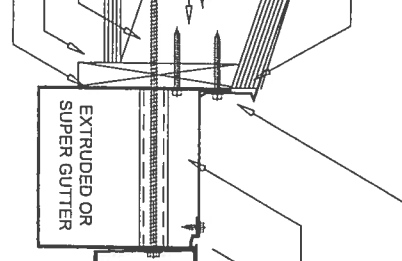
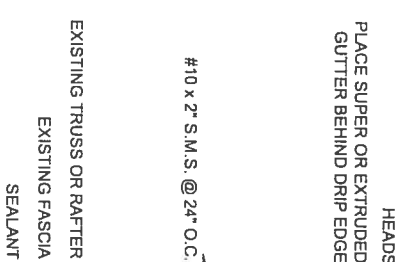
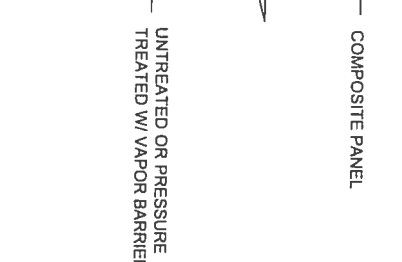
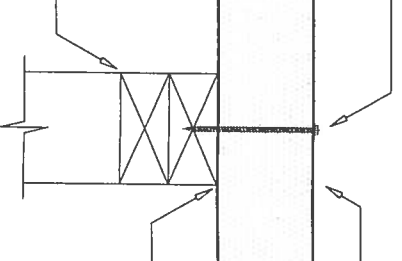
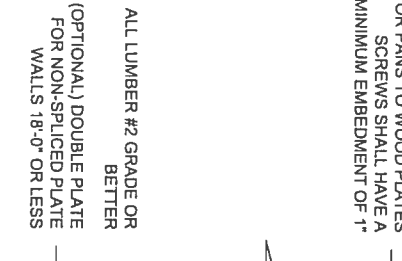
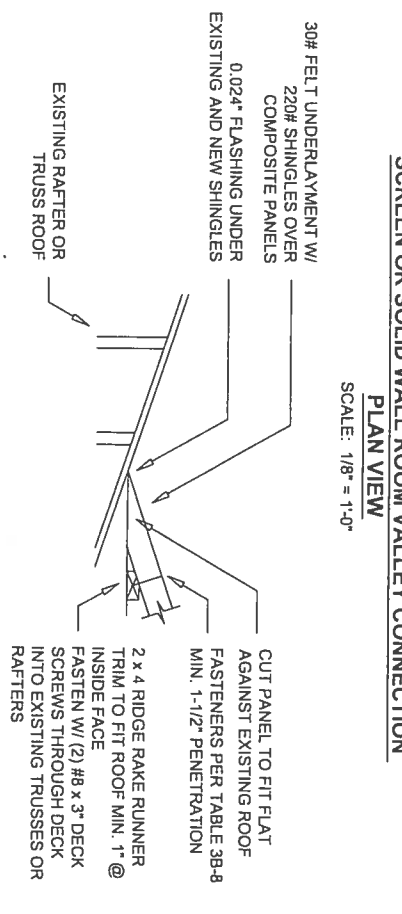

A - A - SECTION VIEW
SCALE: 1/2" = 1'-0"

B - B - PLAN VIEW
SCALE: 1/2" = 1'-0"

EXISTING ROOF TO COMPOSITE ROOF PANEL DETAIL 1
SCALE: 2" = 1'-0"

EXISTING ROOF TO COMPOSITE ROOF PANEL DETAIL 2
SCALE: 2" = 1'-0"

Lawrence E. Bennett, P.E.
FL # 16644
CIVIL ENGINEER - DEVELOPMENT CONSULTANT
P.O. BOX 214368, SOUTH DAYTONA, FL 32121
TELEPHONE: (386) 767-4774
FAX: (386) 767-6556

STRUCTURES WITH WOOD FRAME WALLS & ALUMINUM ROOF SYSTEMS
ALUMINUM STRUCTURES DESIGN MANUAL
2004 FLORIDA BUILDING CODE
MAY 2004 EDITION
SECTION 7 DETAILS

JAN 01 2006
8C
SHEET SEAL

07-08-2004

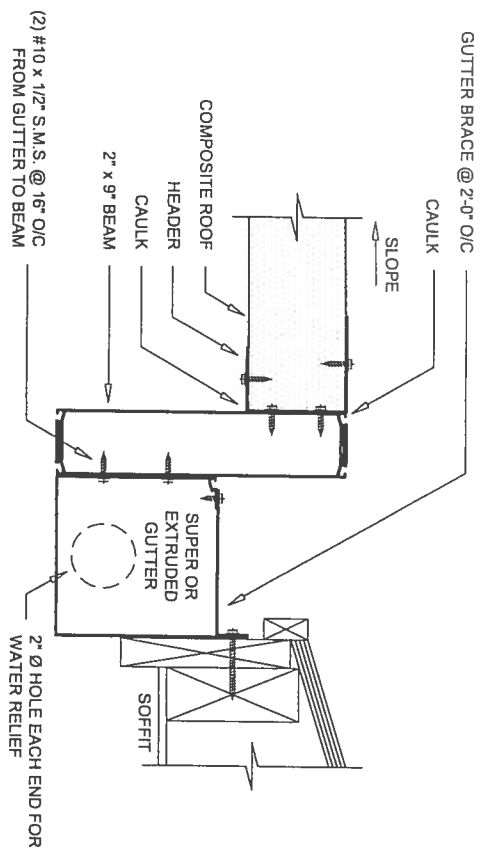

SUPER OR EXTRUDED GUTTER TO 2" x 9" BEAM DETAIL
SCALE: 2" = 1'-0"

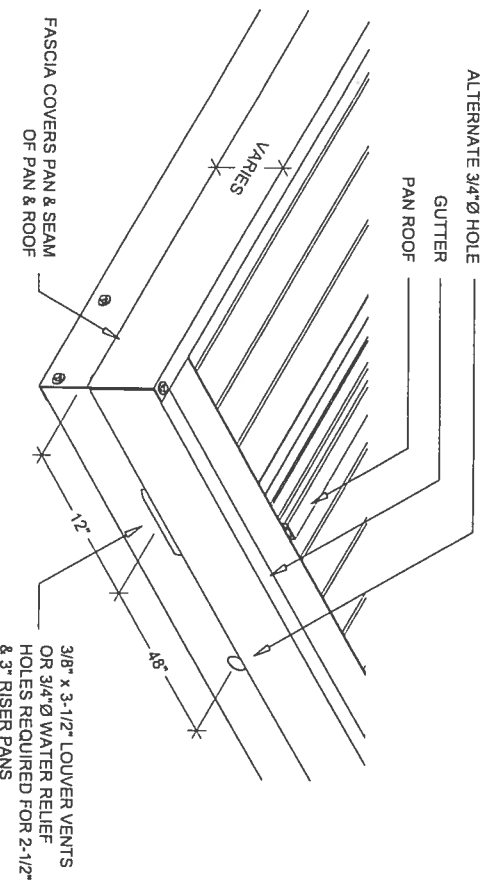

ALTERNATE 3/4" Ø HOLE
GUTTER
PAN ROOF
FASCIA COVERS PAN & SEAM
OF PAN & ROOF
3/8" x 3-1/2" LOUVER VENTS
OR 3/4" Ø WATER RELIEF
HOLES REQUIRED FOR 2-1/2"
GUTTERS FOR 2-1/2" AND LARGER PANS SHALL HAVE A 3/4" Ø HOLE OR A 3/8" x 4" LOUVER @
12" FROM EACH END AND 48" O.C. BELOW THE PAN RISE BREAK TO PREVENT WATER
BUILDUP ON THE ROOF. THIS WATER RELIEF SYSTEM IS RECOMMENDED FOR PANS
SMALLER THAN 2-1/2" ALSO

PAN FASCIA & GUTTER END CAP WATER RELIEF DETAIL
SCALE: 2" = 1'-0"

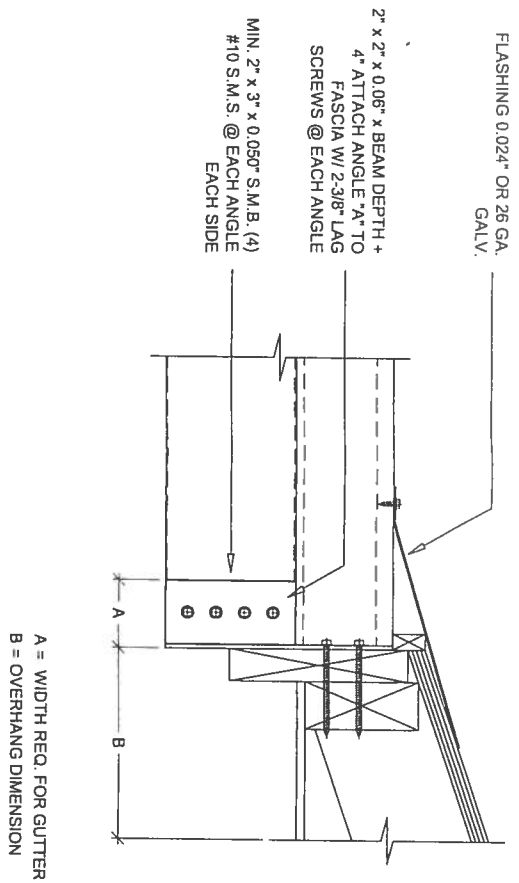

FLASHING 0.024" OR 26 GA.
GALV.
2" x 2" x 0.06" x BEAM DEPTH +
4" ATTACH ANGLE "A" TO
FASCIA W/ 2-3/8" LAG
SCREWS @ EACH ANGLE
MIN. 2" x 3" x 0.050" S.M.B. (4)
#10 S.M.S. @ EACH ANGLE
EACH SIDE
BEAM TO WALL CONNECTION:
(2) 2" x 2" x 0.060" EXTERNALLY MOUNTED ANGLES ATTACHED TO WOOD WALL W/ MIN. (2) 3/8" x 2"
LAG SCREWS PER SIDE OR (2) 1/4" x 2-1/4" CONCRETE ANCHORS TO CONCRETE OR MASONRY
WALL ADD (1) ANCHOR PER SIDE FOR EACH INCH OF BEAM DEPTH LARGER THAN 3"
(ALTERNATE) (1) 1-3/4" x 1-3/4" x 1-3/4" x 1/8" INTERNAL U-CUP ATTACHED TO WOOD WALL W/ MIN. (3)
3/8" x 2" LAG SCREWS PER SIDE OR (3) 1/4" x 2-1/4" CONCRETE ANCHORS TO CONCRETE OR
MASONRY WALL ADD (1) ANCHOR PER SIDE FOR EACH INCH OF BEAM DEPTH LARGER THAN 3"

CANTILEVERED BEAM CONNECTION TO FASCIA DETAIL
SCALE: 2" = 1'-0"

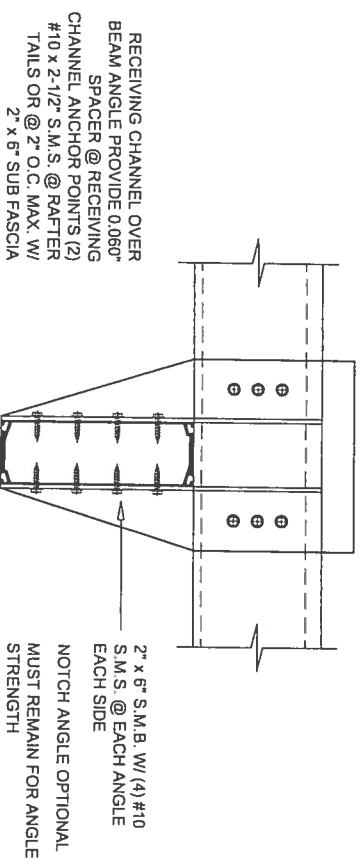

CANTILEVERED BEAM CONNECTION AT FASCIA (END VIEW)
SCALE: 2" = 1'-0"

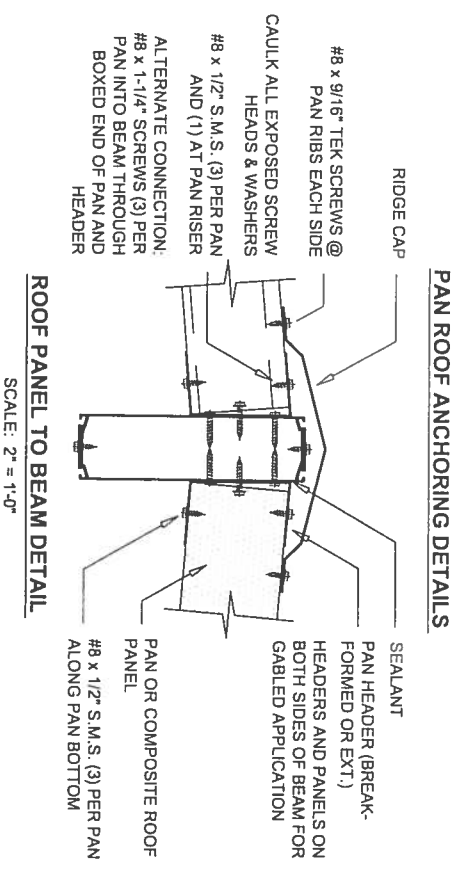

PAN ROOF ANCHORING DETAILS
SCALE: 2" = 1'-0"

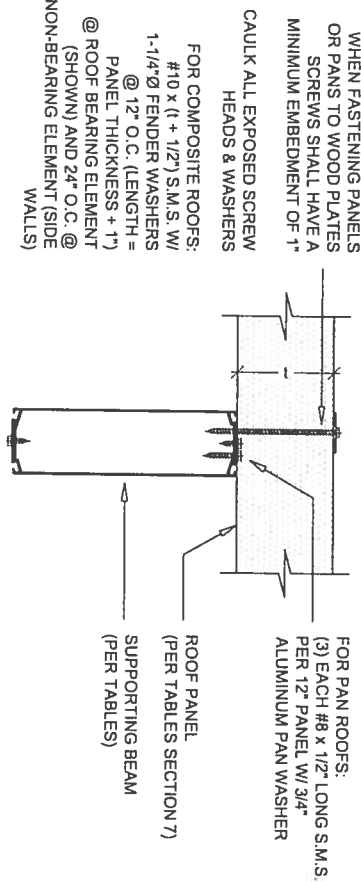

ROOF PANEL TO BEAM FASTENING DETAIL
SCALE: 2" = 1'-0"

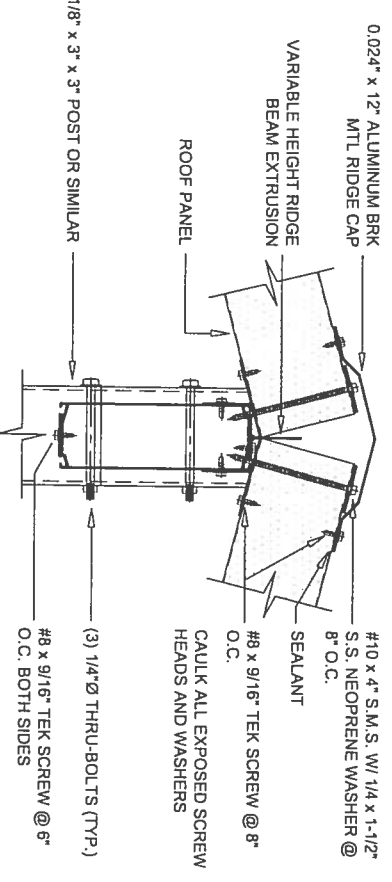

ROOF PANEL TO RIDGE BEAM @ POST DETAIL
SCALE: 2" = 1'-0"

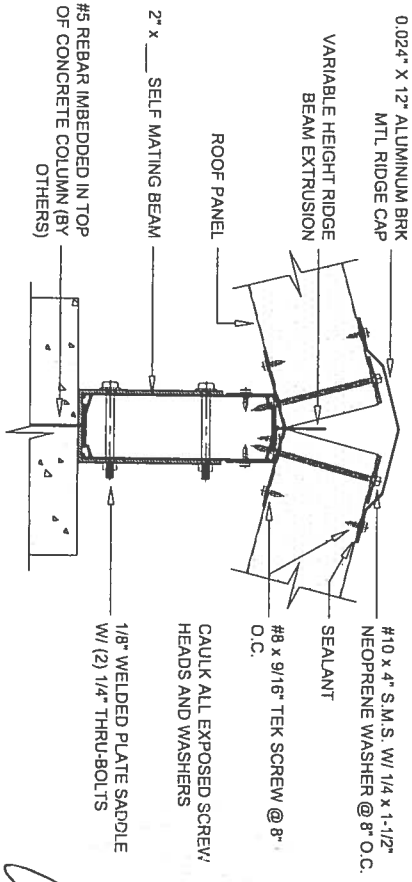

PANEL ROOF TO RIDGE BEAM @ CONCRETE POST DETAIL
SCALE: 2" = 1'-0"

0.024" ALUMINUM COVER PAN
OR CONTINUOUS ALUMINUM
SHEET

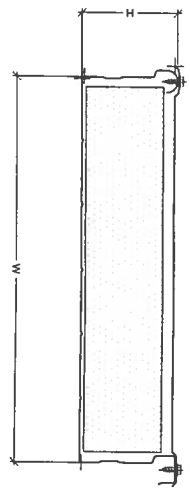

TYPICAL INSULATED PANEL
SCALE: 2" = 1'-0"

#8 x 1/2" CORROSION
RESISTIVE WASHER HEADED
SCREWS @ 24" O.C.
ALTERNATE #8 x 1/2" S.M.S.
W/ 1/2" Ø WASHER.

- NOTES:
1. INSTALL RIGID FOAM INSULATION INTO ALUMINUM ROOF PAN.
 2. COVER INSULATION WITH 0.024" PROTECTOR PANEL WITH OVERLAPPING SEAMS.
 3. INSULATION PANEL SHALL BE CLOSED WITH ALUMINUM END CAP TO SECURE PLACEMENT AND TO DISCOURAGE THE NESTING OF WILDLIFE AND OR INSECTS.
 4. PROTECTOR PANEL WILL BE SECURED BY #8 x 5/8" CORROSION RESISTIVE WASHER HEADED SCREWS.
 5. SCREW PATTERN WILL BE 12" ON ALL PERIMETERS AND 24" O.C. FIELD ON EACH PANEL.
 6. ALUMINUM END CAP WILL BE ATTACHED WITH (3) #8 x 1/2" CORROSION RESISTIVE WASHER HEADED SCREWS.
- NOTE: FOR PANEL SPANS W/ 0.024" ALUMINUM PROTECTIVE COVER MULTIPLE SPANS IN SECTION 5 OR 7 BY 1.28 FOR H-28 METAL & 1.20 FOR H-14 OR H-25 METAL.

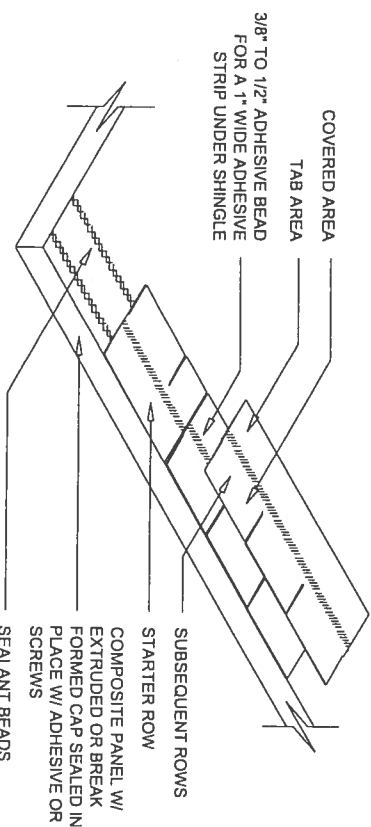

PROFAB COMPOSITE ROOF PANEL WITH SHINGLE FINISH DETAIL
SCALE: N.T.S.

ATTACH SHINGLES TO COMPOSITE ROOF PANELS WITH INDUSTRIAL ADHESIVE. APPLY ADHESIVE IN A CONTINUOUS BEAD 3/8" TO 1/2" DIAMETER SO THAT THERE IS A 1" WIDE STRIP OF ADHESIVE WHEN THE SHINGLE IS PUT IN PLACE.

- FOR AREAS UP TO 120 M.P.H. WIND ZONE:
- 1) STARTER ROWS OF SHINGLES SHALL HAVE ONE STRIP OF ADHESIVE UNDER THE SHINGLE AT MID COVERED AREA AND ONE UNDER THE SHINGLE AT MID TAB AREA. STARTER SHINGLE ROW INSTALLED WITH THE TABS FACING IN THE UPWARD DIRECTION OF THE ROOF SLOPE.
 - 2) SUBSEQUENT ROWS OF SHINGLES INSTALLED WITH THE TABS FACING IN THE DOWNWARD DIRECTION OF THE ROOF SLOPE WITH ONE STRIP OF ADHESIVE UNDER THE SHINGLE AT MID COVERED AREA.
- FOR AREAS ABOVE 120 M.P.H. WIND ZONE:
- 1) STARTER ROWS OF SHINGLES SHALL HAVE TWO STRIPS OF ADHESIVE UNDER THE SHINGLE AT MID COVERED AREA AND TWO STRIPS AT MID TAB AREA. SHINGLE ROW INSTALLED WITH THE TABS FACING IN THE UPWARD DIRECTION OF THE ROOF SLOPE.
 - 2) SUBSEQUENT ROWS OF SHINGLES INSTALLED PER PREVIOUS SPECIFICATION WITH TWO STRIPS OF ADHESIVE AT MID COVERED AREA.

* ADHESIVE: CHEM REX - PL PREMIUM 948 URETHANE ADHESIVE OR OSI - RF-140
MINIMUM ROOF SLOPE: 2" IN 12"

COVERED AREA
TAB AREA W/ 1" ROOFING
NAILS
INSTALLED PER
MANUFACTURERS
SPECIFICATION FOR NUMBER
AND LOCATION

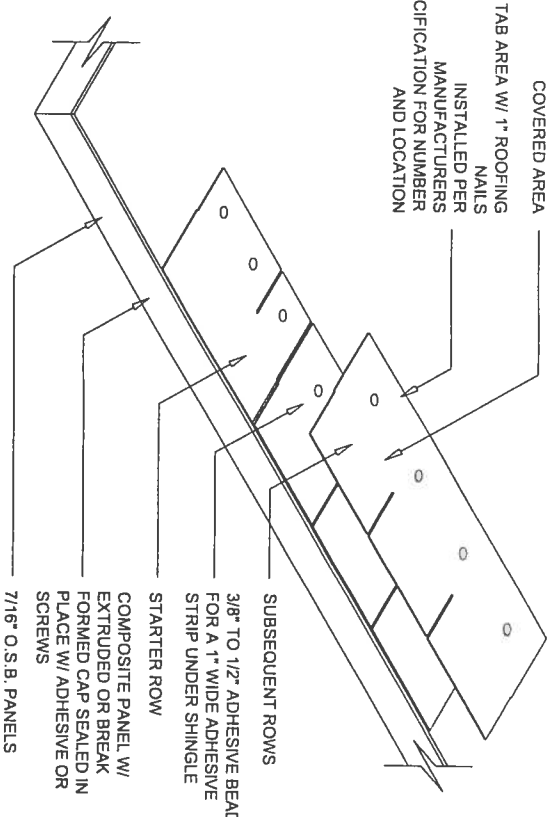

PROFAB COMPOSITE ROOF PANEL WITH O.S.B.
AND STANDARD SHINGLE FINISH DETAIL
SCALE: N.T.S.

- SPECIFICATIONS FOR APPLYING O.S.B. AND SHINGLES FOR ROOF SLOPES OF 3:12 AND GREATER
1. INSTALL PROFAB PANELS IN ACCORDANCE WITH MANUFACTURERS INSTRUCTIONS.
 2. SEAL ALL SEAMS WITH PRO 2000 CHEMREX 948 URETHANE AND CLEAN THE ROOF OF ANY DIRT, GREASE, WATER OR OIL.
 3. APPLY 16 MILS OF MORTON 652 GLUE TO THE PANELS AND INSTALL 7/16" O.S.B. OVER THE GLUE AND PANELS.
 4. INSTALL 15# FELT PAPER IN ACCORDANCE WITH THE FLORIDA BUILDING CODE, 2001 EDITION, SECTION 1507.38.
 5. INSTALL SHINGLES IN ACCORDANCE WITH THE FLORIDA BUILDING CODE, 2001 EDITION, SECTION 1507.3.

SINGLE SPAN CANTILEVER

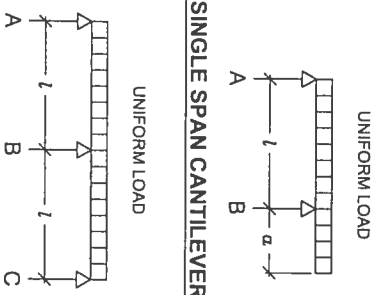

1 OR SINGLE SPAN

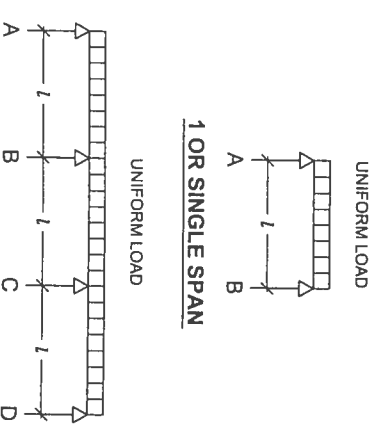

2 SPAN

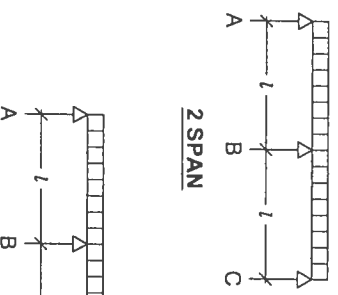

3 SPAN

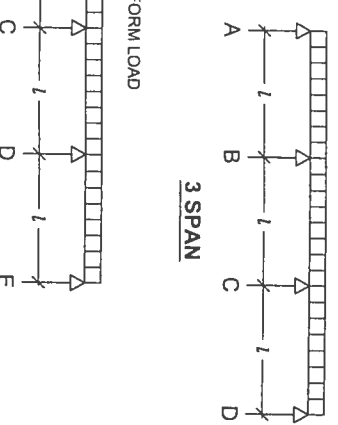

4 SPAN

- NOTES:
1. L = Span Length
 2. All spans listed in the tables are for equally spaced distances between supports or anchor points.
 3. Panels shall not be spliced except at supports.

SPAN EXAMPLES FOR SECTION 7 TABLES
SCALE: N.T.S.

Table 7.1.1 Allowable Spans for Industry Standard Riser Panels for Various Loads
Aluminum Alloy 3105 H-14 or H-25

1-1/4" x 12" x 0.024" 2 or 5 Rib Riser Panels

| Wind Region | Open Structures Mono-Sloped Roof | | | | Screen Rooms & Attached Covers | | | | Glass & Modular Rooms Enclosed | | | | Overhang/Cantilever |
|-------------|----------------------------------|------|-------|-------|--------------------------------|-------|-------|-------|--------------------------------|-------|-------|------|---------------------|
| | span | span | span | span | span | span | span | span | span | span | span | span | |
| 100 MPH | 6-11' | 7-3' | 7-11' | 8-5' | 5-11' | 6-11' | 7-5' | 7-6' | 4-11' | 5-7' | 6-3' | 6-3' | 1-11' |
| 120 MPH | 5-10' | 7-3' | 7-4' | 8-2' | 5-2' | 6-8' | 6-8' | 4-5' | 5-9' | 5-9' | 3-7' | 1-9' | 1-10' |
| 123 MPH | 5-9' | 7-3' | 7-3' | 8-2' | 5-2' | 6-8' | 6-8' | 4-5' | 5-9' | 5-9' | 3-5' | 1-8' | 1-8' |
| 130 MPH | 5-8' | 6-9' | 6-11' | 4-11' | 6-2' | 6-3' | 4-2' | 5-2' | 5-2' | 5-2' | 3-11' | 1-8' | 1-8' |
| 140 MPH | 4-8' | 5-9' | 5-10' | 4-8' | 5-9' | 5-10' | 3-11' | 3-11' | 4-11' | 4-11' | 5-0' | 1-7' | 1-7' |
| 150 MPH | 4-8' | 5-9' | 5-10' | 4-8' | 5-9' | 5-9' | 3-10' | 3-10' | 4-8' | 4-8' | 4-10' | 1-5' | 1-5' |

1-1/4" x 12" x 0.030" 2 or 5 Rib Riser Panels

| Wind Region | Open Structures Mono-Sloped Roof | | | | Screen Rooms & Attached Covers | | | | Glass & Modular Rooms Enclosed | | | | Overhang/Cantilever |
|-------------|----------------------------------|------|-------|-------|--------------------------------|------|------|------|--------------------------------|-------|-------|-------|---------------------|
| | span | span | span | span | span | span | span | span | span | span | span | span | |
| 100 MPH | 6-11' | 8-4' | 8-10' | 9-0' | 6-5' | 8-1' | 8-3' | 5-4' | 6-7' | 6-9' | 6-9' | 2-11' | 2-11' |
| 120 MPH | 5-7' | 8-4' | 8-10' | 9-0' | 5-11' | 7-5' | 7-7' | 5-0' | 6-2' | 6-4' | 6-4' | 1-11' | 1-11' |
| 123 MPH | 5-7' | 8-4' | 8-10' | 9-0' | 5-11' | 7-5' | 7-7' | 5-0' | 6-2' | 6-4' | 6-4' | 1-10' | 1-10' |
| 130 MPH | 5-6' | 7-7' | 7-11' | 8-1' | 5-8' | 7-0' | 7-2' | 4-9' | 5-0' | 5-10' | 5-10' | 1-10' | 1-10' |
| 140 MPH | 4-11' | 7-3' | 7-5' | 5-4' | 6-2' | 6-7' | 7-0' | 4-8' | 5-0' | 5-10' | 5-10' | 1-8' | 1-8' |
| 150 MPH | 4-11' | 6-2' | 6-3' | 4-11' | 6-2' | 6-3' | 4-3' | 4-3' | 5-3' | 5-3' | 5-5' | 1-9' | 1-9' |

1-1/4" x 12" x 0.050" 2 or 5 Rib Riser Panels

| Wind Region | Open Structures Mono-Sloped Roof | | | | Screen Rooms & Attached Covers | | | | Glass & Modular Rooms Enclosed | | | | Overhang/Cantilever |
|-------------|----------------------------------|-------|-------|-------|--------------------------------|------|------|------|--------------------------------|-------|-------|-------|---------------------|
| | span | span | span | span | span | span | span | span | span | span | span | span | |
| 100 MPH | 8-5' | 10-4' | 10-7' | 7-8' | 9-6' | 9-8' | 9-8' | 6-3' | 7-11' | 8-2' | 8-2' | 2-5' | 2-5' |
| 110 MPH | 7-11' | 9-9' | 9-11' | 7-0' | 8-10' | 9-1' | 7-3' | 5-1' | 6-10' | 6-11' | 6-11' | 2-2' | 2-2' |
| 120 MPH | 7-4' | 9-3' | 9-5' | 6-8' | 8-4' | 8-6' | 8-6' | 5-6' | 6-10' | 6-11' | 6-11' | 2-2' | 2-2' |
| 123 MPH | 7-2' | 9-1' | 9-3' | 6-6' | 8-3' | 8-5' | 5-5' | 5-5' | 6-9' | 6-10' | 6-10' | 2-1' | 2-1' |
| 130 MPH | 6-11' | 8-8' | 8-10' | 6-3' | 7-11' | 8-2' | 5-3' | 5-3' | 6-6' | 6-7' | 6-7' | 2-1' | 2-1' |
| 140 MPH | 5-10' | 7-2' | 7-4' | 5-10' | 7-2' | 7-4' | 5-0' | 5-0' | 6-2' | 6-4' | 6-4' | 1-11' | 1-11' |
| 150 MPH | 5-10' | 7-2' | 7-4' | 5-8' | 7-0' | 7-2' | 4-9' | 4-9' | 5-11' | 5-11' | 6-0' | 1-10' | 1-10' |

Note: Total roof panel width = room width + wall width + overhang

Table 7.1.2 Allowable Spans for Industry Standard Riser Panels for Various Loads
Aluminum Alloy 3105 H-14 or H-25

1-1/2" x 12" x 0.024" 2 or 5 Rib Riser Panels

| Wind Region | Open Structures Mono-Sloped Roof | | | | Screen Rooms & Attached Covers | | | | Glass & Modular Rooms Enclosed | | | | Overhang/Cantilever |
|-------------|----------------------------------|--------|--------|--------|--------------------------------|--------|--------|--------|--------------------------------|--------|-------|-------|---------------------|
| | span | span | span | span | span | span | span | span | span | span | span | span | |
| 100 MPH | 16-11' | 21-0' | 21-5' | 15-11' | 20-4' | 20-9' | 13-6' | 16-8' | 17-7' | 17-7' | 4-0' | 4-0' | 4-0' |
| 110 MPH | 16-6' | 21-0' | 21-5' | 14-10' | 19-3' | 19-8' | 12-8' | 15-8' | 16-0' | 16-0' | 4-0' | 4-0' | 4-0' |
| 120 MPH | 15-7' | 20-4' | 20-9' | 14-3' | 18-4' | 18-9' | 11-6' | 14-9' | 15-0' | 15-0' | 4-0' | 4-0' | 4-0' |
| 123 MPH | 15-4' | 19-10' | 20-3' | 13-11' | 17-1' | 18-4' | 11-4' | 14-6' | 14-9' | 14-9' | 4-0' | 4-0' | 4-0' |
| 130 MPH | 14-10' | 18-9' | 19-2' | 13-6' | 16-8' | 17-7' | 10-11' | 13-11' | 14-3' | 14-3' | 3-11' | 3-11' | 3-11' |
| 140 MPH | 11-9' | 14-7' | 14-10' | 11-9' | 14-7' | 14-10' | 10-5' | 13-4' | 13-7' | 13-7' | 3-11' | 3-11' | 3-11' |
| 150 MPH | 11-9' | 14-7' | 14-10' | 11-9' | 14-7' | 14-10' | 9-11' | 12-9' | 12-11' | 12-11' | 3-9' | 3-9' | 3-9' |

1-1/2" x 12" x 0.030" 2 or 5 Rib Riser Panels

| Wind Region | Open Structures Mono-Sloped Roof | | | | Screen Rooms & Attached Covers | | | | Glass & Modular Rooms Enclosed | | | | Overhang/Cantilever |
|-------------|----------------------------------|--------|--------|--------|--------------------------------|--------|--------|--------|--------------------------------|--------|-------|-------|---------------------|
| | span | span | span | span | span | span | span | span | span | span | span | span | |
| 100 MPH | 16-11' | 21-0' | 21-5' | 15-11' | 20-4' | 20-9' | 13-6' | 16-8' | 17-7' | 17-7' | 4-0' | 4-0' | 4-0' |
| 110 MPH | 16-6' | 21-0' | 21-5' | 14-10' | 19-3' | 19-8' | 12-8' | 15-8' | 16-0' | 16-0' | 4-0' | 4-0' | 4-0' |
| 120 MPH | 15-7' | 20-4' | 20-9' | 14-3' | 18-4' | 18-9' | 11-6' | 14-9' | 15-0' | 15-0' | 4-0' | 4-0' | 4-0' |
| 123 MPH | 15-4' | 19-10' | 20-3' | 13-11' | 17-1' | 18-4' | 11-4' | 14-6' | 14-9' | 14-9' | 4-0' | 4-0' | 4-0' |
| 130 MPH | 14-10' | 18-9' | 19-2' | 13-6' | 16-8' | 17-7' | 10-11' | 13-11' | 14-3' | 14-3' | 3-11' | 3-11' | 3-11' |
| 140 MPH | 11-9' | 14-7' | 14-10' | 11-9' | 14-7' | 14-10' | 10-5' | 13-4' | 13-7' | 13-7' | 3-11' | 3-11' | 3-11' |
| 150 MPH | 11-9' | 14-7' | 14-10' | 11-9' | 14-7' | 14-10' | 9-11' | 12-9' | 12-11' | 12-11' | 3-9' | 3-9' | 3-9' |

1-1/2" x 12" x 0.050" 2 or 5 Rib Riser Panels

| Wind Region | Open Structures Mono-Sloped Roof | | | | Screen Rooms & Attached Covers | | | | Glass & Modular Rooms Enclosed | | | | Overhang/Cantilever |
|-------------|----------------------------------|--------|--------|-------|--------------------------------|-------|-------|-------|--------------------------------|-------|-------|-------|---------------------|
| | span | span | span | span | span | span | span | span | span | span | span | span | |
| 100 MPH | 9-4' | 12-3' | 12-6' | 9-1' | 11-6' | 11-6' | 7-5' | 9-5' | 9-8' | 9-8' | 2-11' | 2-11' | 2-11' |
| 110 MPH | 8-11' | 11-7' | 11-9' | 8-6' | 10-6' | 10-9' | 6-11' | 8-10' | 8-11' | 8-11' | 2-8' | 2-8' | 2-8' |
| 120 MPH | 8-11' | 10-11' | 11-2' | 8-0' | 9-11' | 10-1' | 6-7' | 8-4' | 8-4' | 8-4' | 2-7' | 2-7' | 2-7' |
| 123 MPH | 8-8' | 10-9' | 10-11' | 7-11' | 9-9' | 9-11' | 6-8' | 8-3' | 8-4' | 8-4' | 2-6' | 2-6' | 2-6' |
| 130 MPH | 8-4' | 10-4' | 10-6' | 7-5' | 9-5' | 9-8' | 6-3' | 7-11' | 8-1' | 8-1' | 2-5' | 2-5' | 2-5' |
| 140 MPH | 6-11' | 8-6' | 8-8' | 6-11' | 8-6' | 8-8' | 5-11' | 7-4' | 7-6' | 7-6' | 2-4' | 2-4' | 2-4' |
| 150 MPH | 6-11' | 8-6' | 8-8' | 6-9' | 8-6' | 8-8' | 5-8' | 7-0' | 7-2' | 7-2' | 2-2' | 2-2' | 2-2' |

Note: Total roof panel width = room width + wall width + overhang

Table 7.1.3 Allowable Spans for Industry Standard Riser Panels for Various Loads
Aluminum Alloy 3105 H-14 or H-25

3" x 12" x 0.024" 2 or 5 Rib Riser Panels

| Wind Region | Open Structures Mono-Sloped Roof | | | | Screen Rooms & Attached Covers | | | | Glass & Modular Rooms Enclosed | | | | Overhang/Cantilever |
|-------------|----------------------------------|--------|--------|-------|--------------------------------|--------|-------|--------|--------------------------------|-------|-------|-------|---------------------|
| | span | span | span | span | span | span | span | span | span | span | span | span | |
| 100 MPH | 14-5' | 17-10' | 18-2' | 13-7' | 16-9' | 17-7' | 11-1' | 14-2' | 14-5' | 14-5' | 4-0' | 4-0' | 4-0' |
| 110 MPH | 13-11' | 17-10' | 18-2' | 11-8' | 14-11' | 15-3' | 10-4' | 13-6' | 13-7' | 13-7' | 3-11' | 3-11' | 3-11' |
| 120 MPH | 13-3' | 16-4' | 17-7' | 11-8' | 14-11' | 15-3' | 10-4' | 13-6' | 13-9' | 13-9' | 3-9' | 3-9' | 3-9' |
| 123 MPH | 13-0' | 16-1' | 16-5' | 11-6' | 14-8' | 14-11' | 9-8' | 12-4' | 12-6' | 12-6' | 3-8' | 3-8' | 3-8' |
| 130 MPH | 12-7' | 15-7' | 15-11' | 11-1' | 14-2' | 14-5' | 9-4' | 11-6' | 11-9' | 11-9' | 3-6' | 3-6' | 3-6' |
| 140 MPH | 10-0' | 12-4' | 12-7' | 10-0' | 12-4' | 12-7' | 8-10' | 10-11' | 11-2' | 11-2' | 3-4' | 3-4' | 3-4' |
| 150 MPH | 10-0' | 12-4' | 12-7' | 10-0' | 12-4' | 12-7' | 8-5' | 10-5' | 10-8' | 10-8' | 3-2' | 3-2' | 3-2' |

3" x 12" x 0.030" 2 or 5 Rib Riser Panels

| Wind Region | Open Structures Mono-Sloped Roof | | | | Screen Rooms & Attached Covers | | | | Glass & Modular Rooms Enclosed | | | | Overhang/Cantilever |
|-------------|----------------------------------|-------|-------|--------|--------------------------------|-------|-------|--------|--------------------------------|-------|-------|-------|---------------------|
| | span | span | span | span | span | span | span | span | span | span | span | span | |
| 100 MPH | 15-7' | 19-3' | 19-8' | 14-8' | 18-8' | 19-1' | 12-5' | 15-4' | 15-7' | 15-7' | 4-0' | 4-0' | 4-0' |
| 110 MPH | 15-1' | 19-3' | 19-8' | 13-7' | 17-8' | 18-0' | 11-2' | 14-5' | 14-8' | 14-8' | 4-0' | 4-0' | 4-0' |
| 120 MPH | 14-3' | 18-8' | 19-1' | 13-1' | 16-2' | 16-5' | 10-7' | 13-6' | 13-9' | 13-9' | 4-0' | 4-0' | 4-0' |
| 123 MPH | 14-1' | 18-2' | 18-7' | 12-10' | 16-2' | 16-5' | 10-3' | 13-3' | 13-7' | 13-7' | 3-11' | 3-11' | 3-11' |
| 130 MPH | 13-7' | 17-4' | 17-7' | 12-5' | 15-4' | 15-7' | 10-1' | 12-10' | 13-1' | 13-1' | 3-10' | 3-10' | 3-10' |
| 140 MPH | 10-10' | 13-4' | 13-8' | 10-10' | 13-4' | 13-8' | 9-7' | 11-10' | 12-6' | 12-6' | 3-7' | 3-7' | 3-7' |
| 150 MPH | 10-10' | 13-4' | 13-8' | 10-10' | 13-4' | 13-8' | 9-1' | 11-3' | 11-6' | 11-6' | 3-5' | 3-5' | 3-5' |

3" x 12" x 0.050" 2 or 5 Rib Riser Panels

| Wind Region | Open Structures Mono-Sloped Roof | | | | Screen Rooms & Attached Covers | | | | Glass & Modular Rooms Enclosed | | | | Overhang/Cantilever |
|-------------|----------------------------------|-------|--------|--------|--------------------------------|--------|--------|-------|--------------------------------|--------|------|------|---------------------|
| | span | span | span | span | span | span | span | span | span | span | span | span | |
| 100 MPH | 18-3' | 22-6' | 22-11' | 17-8' | 21-10' | 22-3' | 14-5' | 18-6' | 18-10' | 18-10' | 4-0' | 4-0' | 4-0' |
| 110 MPH | 18-3' | 22-6' | 22-11' | 15-11' | 20-7' | 21-0' | 13-7' | 17-7' | 17-11' | 17-11' | 4-0' | 4-0' | 4-0' |
| 120 MPH | 17-8' | 22-3' | 22-3' | 15-3' | 19-8' | 20-1' | 12-9' | 15-9' | 16-1' | 16-1' | 4-0' | 4-0' | 4-0' |
| 123 MPH | 16-5' | 21-3' | 21-8' | 15-0' | 19-3' | 19-8' | 12-7' | 15-6' | 15-10' | 15-10' | 4-0' | 4-0' | 4-0' |
| 130 MPH | 15-11' | 20-6' | 20-6' | 14-6' | 18-10' | 11-9' | 14-11' | 14-3' | 14-3' | 14-3' | 4-0' | 4-0' | 4-0' |
| 140 MPH | 12-8' | 15-7' | 15-7' | 12-8' | 15-7' | 15-11' | 11-2' | 14-4' | 14-7' | 14-7' | 4-0' | 4-0' | 4-0' |
| 150 MPH | 12-8' | 15-7' | 15-11' | 12-8' | 15-7' | 15-11' | 10-8' | 13-8' | 13-11' | 13-11' | 4-0' | 4-0' | 4-0' |

Note: Total roof panel width = room width + wall width + overhang

Table 7.1.4 Allowable Spans for Industry Standard Riser Panels for Various Loads
Aluminum Alloy 3105 H-28

3" x 12" x 0.024" 2 or 5 Rib Riser Panels

| Wind Region | Open Structures Mono-Sloped Roof | | | | Screen Rooms & Attached Covers | | | | Glass & Modular Rooms Enclosed | | | | Overhang/Cantilever |
|-------------|----------------------------------|--------|-------|-------|--------------------------------|-------|-------|-------|--------------------------------|--------|-------|-------|---------------------|
| | span | span | span | span | span | span | span | span | span | span | span | span | |
| 100 MPH | 14-7' | 17-11' | 18-4' | 13-8' | 17-5' | 17-9' | 11-2' | 14-3' | 14-7' | 14-7' | 4-0' | 4-0' | 4-0' |
| 110 MPH | 14-1' | 17-11' | 18-4' | 12-9' | 15-9' | 16-0' | 10-6' | 13-5' | 13-9' | 13-9' | 3-11' | 3-11' | 3-11' |
| 120 MPH | 13-4' | 17-11' | 18-4' | 11-9' | 14-9' | 15-1' | 9-11' | 12-7' | 12-10' | 12-10' | 3-9' | 3-9' | 3-9' |
| 123 MPH | 13-2' | 16-3' | 17-4' | 11-7' | 14-10' | 15-1' | 8-9' | 12-5' | 12-8' | 12-8' | 3-8' | 3-8' | 3-8' |
| 130 MPH | 12-9' | 15-9' | 16-0' | 11-2' | 14- | | | | | | | | |