



Lumber design values are in accordance with ANSI/TPI 1 section 6.3
These truss designs rely on lumber values established by others.

RE: 5263975 -

MiTek, Inc.

16023 Swingley Ridge Rd.
Chesterfield, MO 63017
314-934-1200

Site Information:

Customer Info: CHRISMILL HOMES Project Name: Wilson-Dempsey Res. Model: Custom
Lot/Block: N/A Subdivision: N/A
Address: TBD, N/A
City: White Springs, State: FL

Name Address and License # of Structural Engineer of Record, If there is one, for the building.

Name: License #:
Address:
City: State:

General Truss Engineering Criteria & Design Loads (Individual Truss Design Drawings Show Special Loading Conditions):

Design Code: FBC2023/TPI2014 Design Program: MiTek 20/20 8.8
Wind Code: ASCE 7-22 Wind Speed: 130 mph
Roof Load: 40.0 psf Floor Load: N/A psf

This package includes 18 individual, Truss Design Drawings and 0 Additional Drawings.
With my seal affixed to this sheet, I hereby certify that I am the Truss Design Engineer and this index sheet conforms to 61G15-31.003, section 5 of the Florida Board of Professional Engineers Rules.

No.	Seal#	Truss Name	Date	No.	Seal#	Truss Name	Date
1	T40209552	PB01	2/23/26	15	T40209566	T10G	2/23/26
2	T40209553	PB01G	2/23/26	16	T40209567	T11	2/23/26
3	T40209554	T01	2/23/26	17	T40209568	T11G	2/23/26
4	T40209555	T01G	2/23/26	18	T40209569	V01	2/23/26
5	T40209556	T02	2/23/26				
6	T40209557	T03	2/23/26				
7	T40209558	T04	2/23/26				
8	T40209559	T05	2/23/26				
9	T40209560	T06	2/23/26				
10	T40209561	T06G	2/23/26				
11	T40209562	T07	2/23/26				
12	T40209563	T08	2/23/26				
13	T40209564	T09	2/23/26				
14	T40209565	T10	2/23/26				

This item has been digitally signed and sealed by ORegan, Philip, PE on the date adjacent to the seal.
Printed copies of this document are not considered signed and sealed and the signature must be verified on any electronic copies

The truss drawing(s) referenced above have been prepared by
MiTek USA, Inc. under my direct supervision based on the parameters
provided by Builders FirstSource-Lake City, FL.

Truss Design Engineer's Name: ORegan, Philip
My license renewal date for the state of Florida is February 28, 2027.

IMPORTANT NOTE: The seal on these truss component designs is a certification that the engineer named is licensed in the jurisdiction(s) identified and that the designs comply with ANSI/TPI 1. These designs are based upon parameters shown (e.g., loads, supports, dimensions, shapes and design codes), which were given to MiTek or TRENCO. Any project specific information included is for MiTek's or TRENCO's customers file reference purpose only, and was not taken into account in the preparation of these designs. MiTek or TRENCO has not independently verified the applicability of the design parameters or the designs for any particular building. Before use, the building designer should verify applicability of design parameters and properly incorporate these designs into the overall building design per ANSI/TPI 1, Chapter 2.

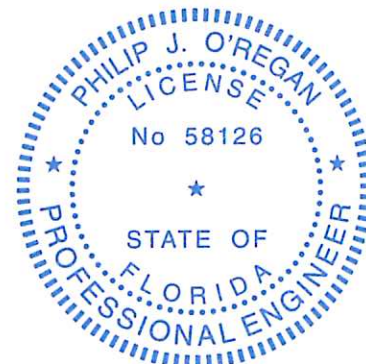

Philip J. O'Regan PE No.58126
MiTek Inc. DBA MiTek USA FL Cert 6634
16023 Swingley Ridge Rd. Chesterfield, MO 63017
Date:

February 23,2026

Job 5263975	Truss PB01	Truss Type Piggyback	Qty 15	Ply 1	Job Reference (optional) T40209552
----------------	---------------	-------------------------	-----------	----------	---------------------------------------

Builders FirstSource (Lake City,FL), Lake City, FL - 32055,

Run: 8.83 S Jan 22 2026 Print: 8.830 S Jan 22 2026 MiTek Industries, Inc. Fri Feb 20 08:24:05
ID:fCd0eXKzXkLaF1y3N30J82zjIMV-RfC?PsB70Hq3NSgPqnL8w3uitXBGKwRcDol7J4zJC7f

Page: 1

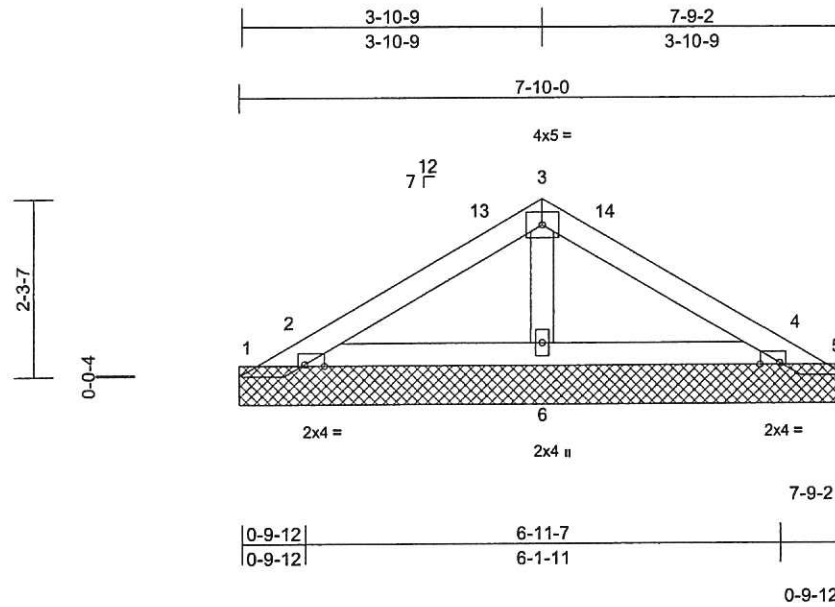

Scale = 1:29.8

Plate Offsets (X, Y): [2:0-3-1,Edge], [4:0-3-1,Edge]

Loading	(psf)	Spacing	2-0-0	CSI	DEFL	in	(loc)	l/def	L/d	PLATES	GRIP
TCLL (roof)	20.0	Plate Grip DOL	1.25	TC	0.14	Vert(LL)	n/a	-	n/a	999	244/190
TCDL	10.0	Lumber DOL	1.25	BC	0.07	Vert(TL)	n/a	-	n/a	999	
BCLL	0.0*	Rep Stress Incr	YES	WB	0.02	Horiz(TL)	0.00	4	n/a	n/a	
BCDL	10.0	Code	FBC2023/TPI2014	Matrix-MP							
										Weight: 25 lb	FT = 20%

LUMBER

TOP CHORD 2x4 SP No.2
BOT CHORD 2x4 SP No.2
OTHERS 2x4 SP No.3

BRACING

TOP CHORD Structural wood sheathing directly applied or 6-0-0 oc purlins.
BOT CHORD Rigid ceiling directly applied or 10-0-0 oc bracing.

REACTIONS (size) 1=7-10-0, 2=7-10-0, 4=7-10-0, 5=7-10-0, 6=7-10-0

Max Horiz 1=52 (LC 9)
Max Uplift 1=-125 (LC 19), 2=-132 (LC 12), 4=-123 (LC 13), 5=-102 (LC 20), 6=-19 (LC 12)
Max Grav 1=72 (LC 12), 2=324 (LC 19), 4=298 (LC 20), 5=54 (LC 13), 6=189 (LC 1)

FORCES (lb) - Maximum Compression/Maximum Tension

TOP CHORD 1-2=-71/117, 2-3=-83/77, 3-4=-80/71, 4-5=-46/72
BOT CHORD 2-6=-38/48, 4-6=-40/49
WEBS 3-6=-99/36

NOTES

- 1) Unbalanced roof live loads have been considered for this design.
- 2) Wind: ASCE 7-22; Vult=130mph (3-second gust) Vasd=101mph; TCDL=4.2psf; BCDL=3.0psf; h=18ft; Cat. II; Exp B; Enclosed; MWFRS (envelope) exterior (2) zone and C-C Zone3 0-3-11 to 3-3-11, Zone1 3-3-11 to 3-11-0, Zone3 3-11-0 to 7-6-5 zone;C-C for members and forces & MWFRS for reactions shown; Lumber DOL=1.60 plate grip DOL=1.60
- 3) Truss designed for wind loads in the plane of the truss only. For studs exposed to wind (normal to the face), see Standard Industry Gable End Details as applicable, or consult qualified building designer as per ANSI/TPI 1.

- 4) Building Designer / Project engineer responsible for verifying applied roof live load shown covers rain loading requirements specific to the use of this truss component.
- 5) Gable requires continuous bottom chord bearing.
- 6) Gable studs spaced at 4-0-0 oc.
- 7) This truss has been designed for a 10.0 psf bottom chord live load nonconcurrent with any other live loads.
- 8) * This truss has been designed for a live load of 20.0psf on the bottom chord in all areas where a rectangle 3-06-00 tall by 2-00-00 wide will fit between the bottom chord and any other members.
- 9) Provide mechanical connection (by others) of truss to bearing plate capable of withstanding 132 lb uplift at joint 2, 123 lb uplift at joint 4, 125 lb uplift at joint 1, 102 lb uplift at joint 5, 19 lb uplift at joint 6, 132 lb uplift at joint 2 and 123 lb uplift at joint 4.
- 10) See Standard Industry Piggyback Truss Connection Detail for Connection to base truss as applicable, or consult qualified building designer.

LOAD CASE(S) Standard

This item has been digitally signed and sealed by O'Regan, Philip, PE on the date indicated here. Printed copies of this document are not considered signed and sealed and the signature must be verified on any electronic copies.

Philip J. O'Regan PE No.59126
MiTek Inc. DBA MiTek USA FL Cert 6634
16023 Swingley Ridge Rd. Chesterfield, MO 63017
Date:

February 23,2026

WARNING - Verify design parameters and READ NOTES ON THIS AND INCLUDED MITEK REFERENCE PAGE MII-747J rev. 1/2/2023 BEFORE USE.

Design valid for use only with MiTek® connectors. This design is based only upon parameters shown, and is for an individual building component, not a truss system. Before use, the building designer must verify the applicability of design parameters and properly incorporate this design into the overall building design. Bracing indicated is to prevent buckling of individual truss web and/or chord members only. Additional temporary and permanent bracing is always required for stability and to prevent collapse with possible personal injury and property damage. For general guidance regarding the fabrication, storage, delivery, erection and bracing of trusses and truss systems, see ANSI/TPI1 Quality Criteria and DSB-22 available from Truss Plate Institute (www.tpinst.org) and BCSI Building Component Safety Information available from the Structural Building Component Association (www.sbcsccomponents.com)

MiTek®
16023 Swingley Ridge Rd.
Chesterfield, MO 63017
314.434.1200 / MiTek-US.com

Job 5263975	Truss PB01G	Truss Type Piggyback	Qty 2	Ply 1	Job Reference (optional) T40209553
----------------	----------------	-------------------------	----------	----------	---------------------------------------

Builders FirstSource (Lake City,FL), Lake City, FL - 32055,

Run: 8.83 S Jan 22 2026 Print: 8.830 S Jan 22 2026 MiTek Industries, Inc. Fri Feb 20 08:24:07
ID:2CIQC4Ovcfj5i4sm8LnfTAzjszu-RfC?PsB70Hq3NSgPqnL8w3ulTXbGKwRCDoi7J4zJC7f

Page: 1

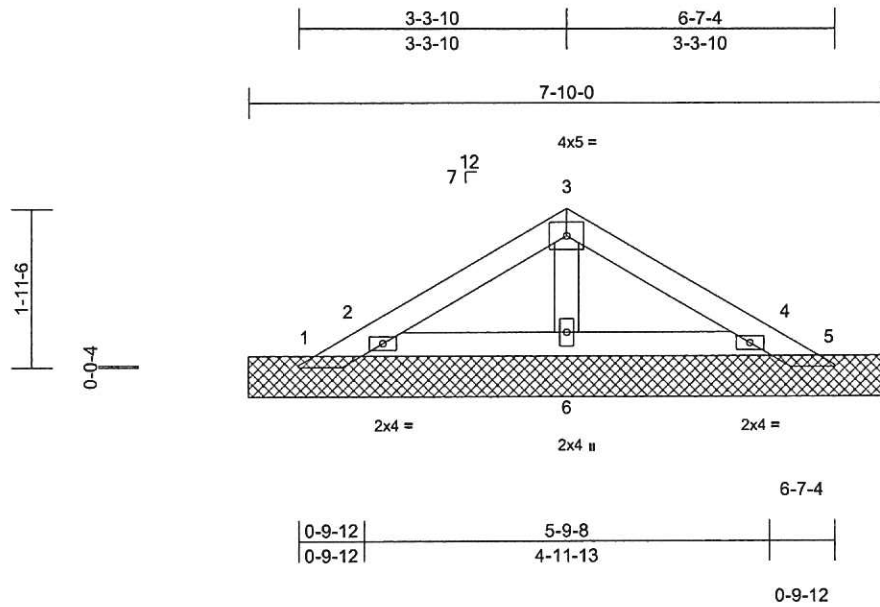

Loading	(psf)	Spacing	2-0-0	CSI	DEFL	in	(loc)	l/defl	L/d	PLATES	GRIP	
TCLL (roof)	20.0	Plate Grip DOL	1.25	TC	0.09	Vert(LL)	n/a	-	n/a	999	MT20	244/190
TCDL	10.0	Lumber DOL	1.25	BC	0.10	Vert(TL)	n/a	-	n/a	999		
BCLL	0.0*	Rep Stress Incr	YES	WB	0.04	Horiz(TL)	0.00	5	n/a	n/a		
BCDL	10.0	Code	FBC2023/TPI2014	Matrix-MP							Weight: 21 lb	FT = 20%

LUMBER
 TOP CHORD 2x4 SP No.2
 BOT CHORD 2x4 SP No.2
 OTHERS 2x4 SP No.3

BRACING
 TOP CHORD Structural wood sheathing directly applied or 6-0-0 oc purlins.
 BOT CHORD Rigid ceiling directly applied or 6-0-0 oc bracing.

REACTIONS (size) 1=7-10-0, 2=7-10-0, 4=7-10-0, 5=7-10-0, 6=7-10-0
 Max Horiz 1=44 (LC 11)
 Max Uplift 1=-66 (LC 19), 2=-82 (LC 12), 4=-1 (LC 13), 5=-24 (LC 13), 6=-65 (LC 13)
 Max Grav 1=42 (LC 12), 2=193 (LC 25), 4=2 (LC 20), 5=80 (LC 1), 6=303 (LC 1)

FORCES (lb) - Maximum Compression/Maximum Tension
 TOP CHORD 3-4=-36/109, 4-5=-38/32, 1-2=-57/82, 2-3=-46/96
 BOT CHORD 2-6=-82/107, 4-6=-82/107
 WEBS 3-6=-191/130

NOTES

- Unbalanced roof live loads have been considered for this design.
- Wind: ASCE 7-22; Vult=130mph (3-second gust) Vasd=101mph; TCDL=4.2psf; BCDL=3.0psf; h=18ft; Cat. II; Exp B; Enclosed; MWFRS (envelope) exterior (2) zone and C-C Zone3 zone;C-C for members and forces & MWFRS for reactions shown; Lumber DOL=1.60 plate grip DOL=1.60
- Truss designed for wind loads in the plane of the truss only. For studs exposed to wind (normal to the face), see Standard Industry Gable End Details as applicable, or consult qualified building designer as per ANSI/TPI 1.
- Building Designer / Project engineer responsible for verifying applied roof live load shown covers rain loading requirements specific to the use of this truss component.

- Gable requires continuous bottom chord bearing.
 - Gable studs spaced at 4-0-0 oc.
 - This truss has been designed for a 10.0 psf bottom chord live load nonconcurrent with any other live loads.
 - * This truss has been designed for a live load of 20.0psf on the bottom chord in all areas where a rectangle 3-06-00 tall by 2-00-00 wide will fit between the bottom chord and any other members.
 - Provide mechanical connection (by others) of truss to bearing plate capable of withstanding 82 lb uplift at joint 2, 1 lb uplift at joint 4, 65 lb uplift at joint 6, 24 lb uplift at joint 5, 66 lb uplift at joint 1, 82 lb uplift at joint 2 and 1 lb uplift at joint 4.
 - See Standard Industry Piggyback Truss Connection Detail for Connection to base truss as applicable, or consult qualified building designer.
- LOAD CASE(S)** Standard

This item has been digitally signed and sealed by ORegan, Philip, PE on the date indicated here. Printed copies of this document are not considered signed and sealed and the signature must be verified on any electronic copies.

Philip J. O'Regan PE No.58126
 MiTek Inc. DBA MiTek USA FL Cert 6634
 16023 Swingley Ridge Rd. Chesterfield, MO 63017
 Date:

February 23,2026

WARNING - Verify design parameters and READ NOTES ON THIS AND INCLUDED MITEK REFERENCE PAGE MII-747J rev. 1/2/2023 BEFORE USE.

Design valid for use only with MiTek® connectors. This design is based only upon parameters shown, and is for an individual building component, not a truss system. Before use, the building designer must verify the applicability of design parameters and properly incorporate this design into the overall building design. Bracing indicated is to prevent buckling of individual truss web and/or chord members only. Additional temporary and permanent bracing is always required for stability and to prevent collapse with possible personal injury and property damage. For general guidance regarding the fabrication, storage, delivery, erection and bracing of trusses and truss systems, see ANSI/TPI1 Quality Criteria and DSB-22 available from Truss Plate Institute (www.tpinst.org) and BCSI Building Component Safety Information available from the Structural Building Component Association (www.sbcsccomponents.com)

MiTek®
 16023 Swingley Ridge Rd.
 Chesterfield, MO 63017
 314.434.1200 / MiTek-US.com

Job 5263975	Truss T01	Truss Type Common	Qty 3	Ply 1	Job Reference (optional)	T40209554
----------------	--------------	----------------------	----------	----------	--------------------------	-----------

Builders FirstSource (Lake City,FL), Lake City, FL - 32055,

Run: 8.83 S Jan 22 2026 Print: 8.830 S Jan 22 2026 MITek Industries, Inc. Fri Feb 20 08:24:07
ID:N4CqUPotYrdzmxTRvXozCCzju0V-RfC?PsB70Hq3NSgPqnL8w3ulTxbGKWrCDoi7J4zJC7f

Page: 1

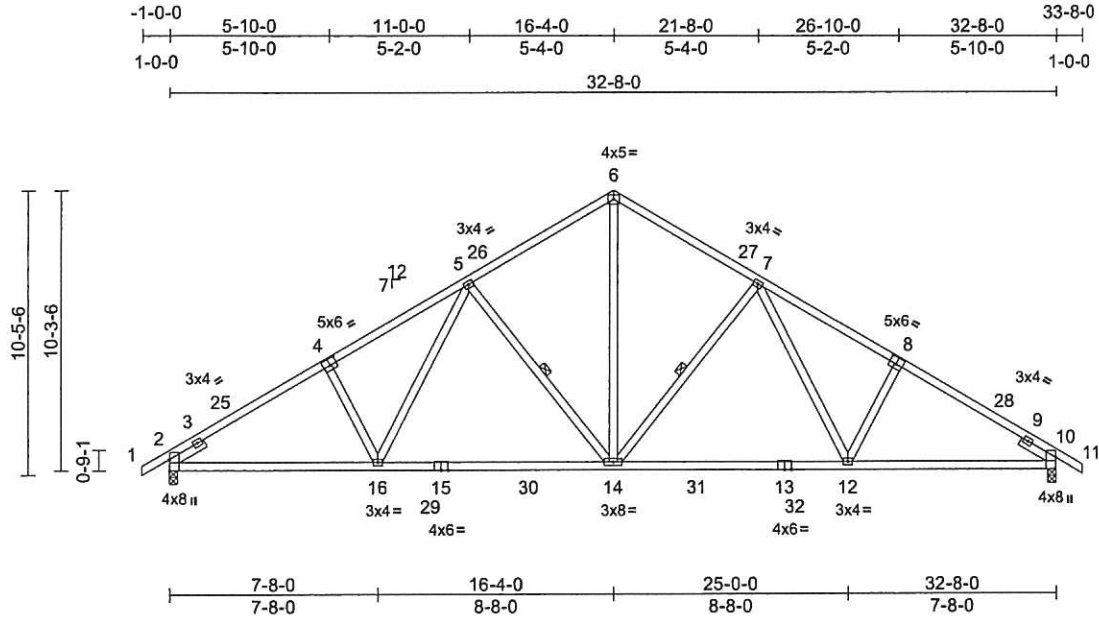

Scale = 1:84.9

Plate Offsets (X, Y): [2:0-5-0,Edge], [4:0-3-0,0-3-0], [8:0-3-0,0-3-0], [10:0-5-0,Edge]

Loading	(psf)	Spacing	2-0-0	CSI	DEFL	in	(loc)	l/defl	L/d	PLATES	GRIP	
TCLL (roof)	20.0	Plate Grip DOL	1.25	TC	0.89	Vert(LL)	-0.26	12-14	>999	240	MT20	244/190
TCDL	10.0	Lumber DOL	1.25	BC	0.99	Vert(CT)	-0.45	12-14	>871	180		
BCLL	0.0*	Rep Stress Incr	YES	WB	0.51	Horz(CT)	0.11	10	n/a	n/a		
BCDL	10.0	Code	FBC2023/TPI2014	Matrix-MS							Weight: 186 lb	FT = 20%

LUMBER

TOP CHORD 2x4 SP No.2
 BOT CHORD 2x4 SP No.2
 WEBS 2x4 SP No.3
 SLIDER Left 2x4 SP No.3 – 1-6-0, Right 2x4 SP No.3 – 1-6-0

BRACING

TOP CHORD Structural wood sheathing directly applied or 2-2-0 oc purlins.
 BOT CHORD Rigid ceiling directly applied or 2-2-0 oc bracing.
 WEBS 1 Row at midpt 5-14, 7-14

REACTIONS

(size) 2=0-3-8, 10=0-3-8
 Max Horiz 2=250 (LC 11)
 Max Uplift 2=-327 (LC 12), 10=-327 (LC 13)
 Max Grav 2=1565 (LC 19), 10=1565 (LC 20)

FORCES

(lb) - Maximum Compression/Maximum Tension
 TOP CHORD 1-2=0/30, 2-5=-2262/496, 5-6=-1542/393, 6-7=-1542/393, 7-10=-2262/497, 10-11=0/30
 BOT CHORD 2-16=-462/2043, 14-16=-322/1727, 12-14=-214/1606, 10-12=-294/1855
 WEBS 5-16=-135/517, 4-16=-212/189, 5-14=-626/290, 6-14=-267/1223, 7-14=-627/290, 7-12=-135/518, 8-12=-212/189

NOTES

- Unbalanced roof live loads have been considered for this design.
- Wind: ASCE 7-22; Vult=130mph (3-second gust) Vasd=101mph; TCDL=4.2psf; BCDL=3.0psf; h=18ft; Cat. II; Exp B; Enclosed; MWFRS (envelope) exterior (2) zone and C-C Zone3 -1-0-0 to 2-3-3, Zone1 2-3-3 to 16-4-0, Zone2 16-4-0 to 20-11-7, Zone1 20-11-7 to 33-8-0 zone;C-C for members and forces & MWFRS for reactions shown; Lumber DOL=1.60 plate grip DOL=1.60

- Building Designer / Project engineer responsible for verifying applied roof live load shown covers rain loading requirements specific to the use of this truss component.
- This truss has been designed for a 10.0 psf bottom chord live load nonconcurrent with any other live loads.
- * This truss has been designed for a live load of 20.0psf on the bottom chord in all areas where a rectangle 3-06-00 tall by 2-00-00 wide will fit between the bottom chord and any other members, with BCDL = 10.0psf.
- Provide mechanical connection (by others) of truss to bearing plate capable of withstanding 327 lb uplift at joint 10 and 327 lb uplift at joint 2.

LOAD CASE(S) Standard

This item has been digitally signed and sealed by O'Regan, Philip, PE on the date indicated here. Printed copies of this document are not considered signed and sealed and the signature must be verified on any electronic copies.

Philip J. O'Regan PE No.58126
 MITek Inc. DBA MITek USA FL Cert 6634
 16023 Swingley Ridge Rd. Chesterfield, MO 63017
 Date:

February 23,2026

WARNING - Verify design parameters and READ NOTES ON THIS AND INCLUDED MITEK REFERENCE PAGE MII-7473 rev. 1/2/2023 BEFORE USE.

Design valid for use only with MiTek® connectors. This design is based only upon parameters shown, and is for an individual building component, not a truss system. Before use, the building designer must verify the applicability of design parameters and properly incorporate this design into the overall building design. Bracing indicated is to prevent buckling of individual truss web and/or chord members only. Additional temporary and permanent bracing is always required for stability and to prevent collapse with possible personal injury and property damage. For general guidance regarding the fabrication, storage, delivery, erection and bracing of trusses and truss systems, see **ANSI/TPI1 Quality Criteria and DSB-22** available from Truss Plate Institute (www.tpinst.org) and **BCSI Building Component Safety Information** available from the Structural Building Component Association (www.sbcsccomponents.com)

MiTek®
 16023 Swingley Ridge Rd.
 Chesterfield, MO 63017
 314.434.1200 / MITek-US.com

Job 5263975	Truss T01G	Truss Type Common Supported Gable	Qty 2	Ply 1	Job Reference (optional)	T40209555
----------------	---------------	--------------------------------------	----------	----------	--------------------------	-----------

Builders FirstSource (Lake City, FL), Lake City, FL - 32055,

Run: 8.83 S Jan 22 2026 Print: 8.830 S Jan 22 2026 MiTek Industries, Inc. Fri Feb 20 08:24:07
ID:8WQOogNQr4mchABSvFBO3zjISu-RC?Psb70Hq3NSgPqnL8w3ulTXbGKwRCDof7J4zJC7f

Page: 1

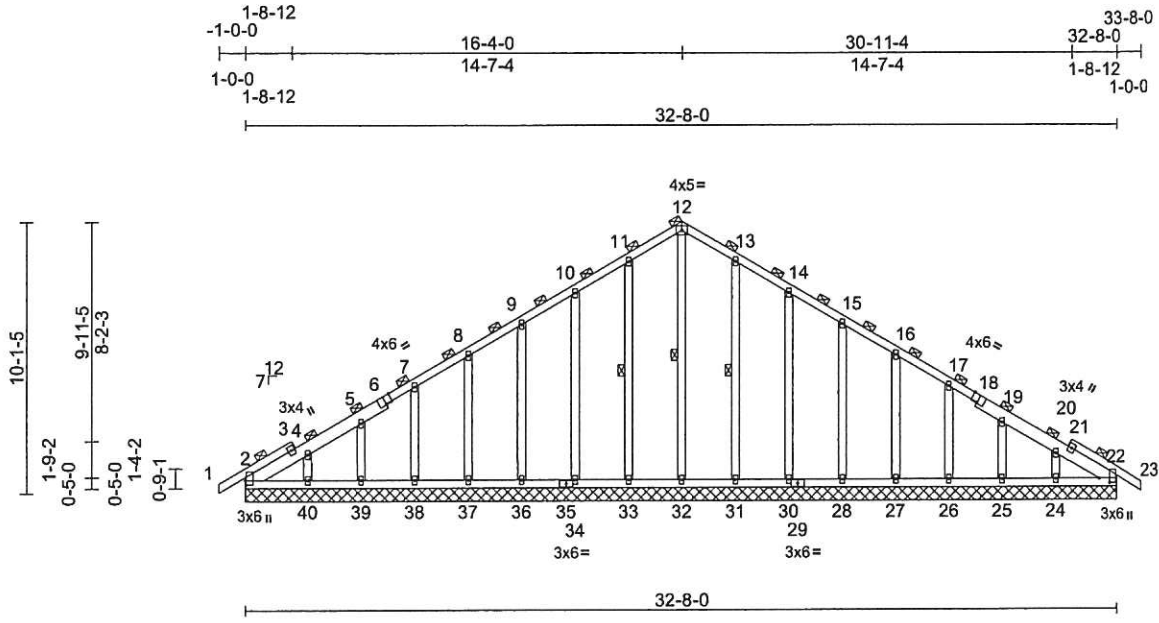

Scale = 1:86.3

Plate Offsets (X, Y): [2:0-2-0,0-0-7], [6:0-3-0,Edge], [18:0-3-0,Edge], [22:0-2-0,0-4-15]

Loading	(psf)	Spacing	2-0-0	CSI	DEFL	in	(loc)	l/defl	L/d	PLATES	GRIP	
TCLL (roof)	20.0	Plate Grip DOL	1.25	TC	Vert(LL)	n/a	-	n/a	999	MT20	244/190	
TCDL	10.0	Lumber DOL	1.25	BC	Vert(CT)	n/a	-	n/a	999			
BCLL	0.0*	Rep Stress Incr	YES	WB	Horz(CT)	0.01	22	n/a	n/a			
BCDL	10.0	Code	FBC2023/TPI2014	Matrix-MS								
											Weight: 236 lb	FT = 20%

LUMBER
TOP CHORD 2x4 SP No.2 *Except* 2-6,18-22:2x6 SP No.2
BOT CHORD 2x4 SP No.2
OTHERS 2x4 SP No.3

BRACING
TOP CHORD 2-0-0 oc purlins (6-0-0 max.).
BOT CHORD Rigid ceiling directly applied or 10-0-0 oc bracing.

WEBS
1 Row at midpt 12-32, 11-33, 13-31

REACTIONS (size)
2=32-8-0, 22=32-8-0, 24=32-8-0, 25=32-8-0, 26=32-8-0, 27=32-8-0, 28=32-8-0, 30=32-8-0, 31=32-8-0, 32=32-8-0, 33=32-8-0, 34=32-8-0, 36=32-8-0, 37=32-8-0, 38=32-8-0, 39=32-8-0, 40=32-8-0

Max Horiz 2=-242 (LC 10)
Max Uplift 2=-62 (LC 8), 22=-15 (LC 9), 24=-97 (LC 13), 25=-66 (LC 13), 26=-78 (LC 13), 27=-74 (LC 13), 28=-74 (LC 13), 30=-79 (LC 13), 31=-67 (LC 13), 33=-71 (LC 12), 34=-78 (LC 12), 36=-74 (LC 12), 37=-74 (LC 12), 38=-81 (LC 12), 39=-60 (LC 12), 40=-103 (LC 12)
Max Grav 2=186 (LC 20), 22=164 (LC 1), 24=190 (LC 20), 25=165 (LC 20), 26=167 (LC 20), 27=168 (LC 20), 28=168 (LC 20), 30=168 (LC 20), 31=173 (LC 20), 32=203 (LC 22), 33=176 (LC 19), 34=167 (LC 19), 36=168 (LC 19), 37=168 (LC 19), 38=171 (LC 19), 39=163 (LC 1), 40=197 (LC 19)

FORCES (lb) - Maximum Compression/Maximum Tension

TOP CHORD
1-2=0/30, 2-4=-199/180, 4-5=-171/156, 5-7=-158/141, 7-8=-137/132, 8-9=-125/151, 9-10=-110/181, 10-11=-117/212, 11-12=-140/236, 12-13=-140/227, 13-14=-117/179, 14-15=-92/130, 15-16=-67/91, 16-17=-65/62, 17-19=-82/51, 19-20=-95/69, 20-22=-140/92, 22-23=0/30

BOT CHORD
2-40=-78/157, 39-40=-78/157, 38-39=-78/157, 37-38=-78/157, 36-37=-78/157, 34-36=-78/157, 33-34=-78/157, 32-33=-78/157, 31-32=-78/157, 30-31=-78/157, 28-30=-78/157, 27-28=-78/157, 26-27=-78/157, 25-26=-78/157, 24-25=-78/157, 22-24=-78/157

WEBS
12-32=-178/63, 11-33=-136/83, 10-34=-127/90, 9-36=-128/86, 8-37=-128/86, 7-38=-129/91, 5-39=-125/80, 4-40=-137/87, 13-31=-133/79, 14-30=-128/91, 15-28=-128/86, 16-27=-128/87, 17-26=-126/88, 19-25=-129/84, 20-24=-138/88

- Gable requires continuous bottom chord bearing.
 - Gable studs spaced at 2-0-0 oc.
 - This truss has been designed for a 10.0 psf bottom chord live load nonconcurrent with any other live loads.
 - * This truss has been designed for a live load of 20.0psf on the bottom chord in all areas where a rectangle 3-06-00 tall by 2-00-00 wide will fit between the bottom chord and any other members.
 - Provide mechanical connection (by others) of truss to bearing plate capable of withstanding 15 lb uplift at joint 22, 62 lb uplift at joint 2, 71 lb uplift at joint 33, 78 lb uplift at joint 34, 74 lb uplift at joint 36, 74 lb uplift at joint 37, 81 lb uplift at joint 38, 60 lb uplift at joint 39, 103 lb uplift at joint 40, 67 lb uplift at joint 31, 79 lb uplift at joint 30, 74 lb uplift at joint 28, 74 lb uplift at joint 27, 78 lb uplift at joint 26, 66 lb uplift at joint 25, 97 lb uplift at joint 24, 15 lb uplift at joint 22 and 62 lb uplift at joint 2.
 - Graphical purlin representation does not depict the size or the orientation of the purlin along the top and/or bottom chord.
- LOAD CASE(S)** Standard

- NOTES**
- Unbalanced roof live loads have been considered for this design.
 - Wind: ASCE 7-22; Vult=130mph (3-second gust) Vasd=101mph; TCDL=4.2psf; BCDL=3.0psf; h=18ft; Cat. II; Exp B; Enclosed; MWFRS (envelope) exterior (2) zone and C-C Zone3 zone; C-C for members and forces & MWFRS for reactions shown; Lumber DOL=1.60 plate grip DOL=1.60
 - Truss designed for wind loads in the plane of the truss only. For studs exposed to wind (normal to the face), see Standard Industry Gable End Details as applicable, or consult qualified building designer as per ANSI/TPI 1.
 - Building Designer / Project engineer responsible for verifying applied roof live load shown covers rain loading requirements specific to the use of this truss component.
 - All plates are 2x4 (||) MT20 unless otherwise indicated.

This item has been digitally signed and sealed by ORegan, Philip, PE on the date indicated here. Printed copies of this document are not considered signed and sealed and the signature must be verified on any electronic copies.

Philip J. O'Regan PE No.58126
MiTek Inc. DBA MiTek USA FL Cert 6634
16023 Swingley Ridge Rd, Chesterfield, MO 63017
Date:

February 23,2026

WARNING - Verify design parameters and READ NOTES ON THIS AND INCLUDED MITEK REFERENCE PAGE MII-7473 rev. 1/2/2023 BEFORE USE.
Design valid for use only with MiTek® connectors. This design is based only upon parameters shown, and is for an individual building component, not a truss system. Before use, the building designer must verify the applicability of design parameters and properly incorporate this design into the overall building design. Bracing indicated is to prevent buckling of individual truss web and/or chord members only. Additional temporary and permanent bracing is always required for stability and to prevent collapse with possible personal injury and property damage. For general guidance regarding the fabrication, storage, delivery, erection and bracing of trusses and truss systems, see ANSI/TPI1 Quality Criteria and DSB-22 available from Truss Plate Institute (www.tpinst.org) and BCSI Building Component Safety Information available from the Structural Building Component Association (www.sbcsccomponents.com)

MiTek®
16023 Swingley Ridge Rd.
Chesterfield, MO 63017
314.434.1200 / MiTek-US.com

Job 5263975	Truss T02	Truss Type Common	Qty 1	Ply 1	Job Reference (optional)	T40209556
----------------	--------------	----------------------	----------	----------	--------------------------	-----------

Builders FirstSource (Lake City, FL), Lake City, FL - 32055.

Run: 8.83 S Jan 22 2026 Print: 8.830 S Jan 22 2026 MiTek Industries, Inc. Fri Feb 20 08:24:08

Page: 1

ID:CJhp0jil7byTfJ7gE47JBozju?L-RIC?PsbB70Hq3NSgPqnL8w3uITxbGKwRCDoi7J4zJC7f

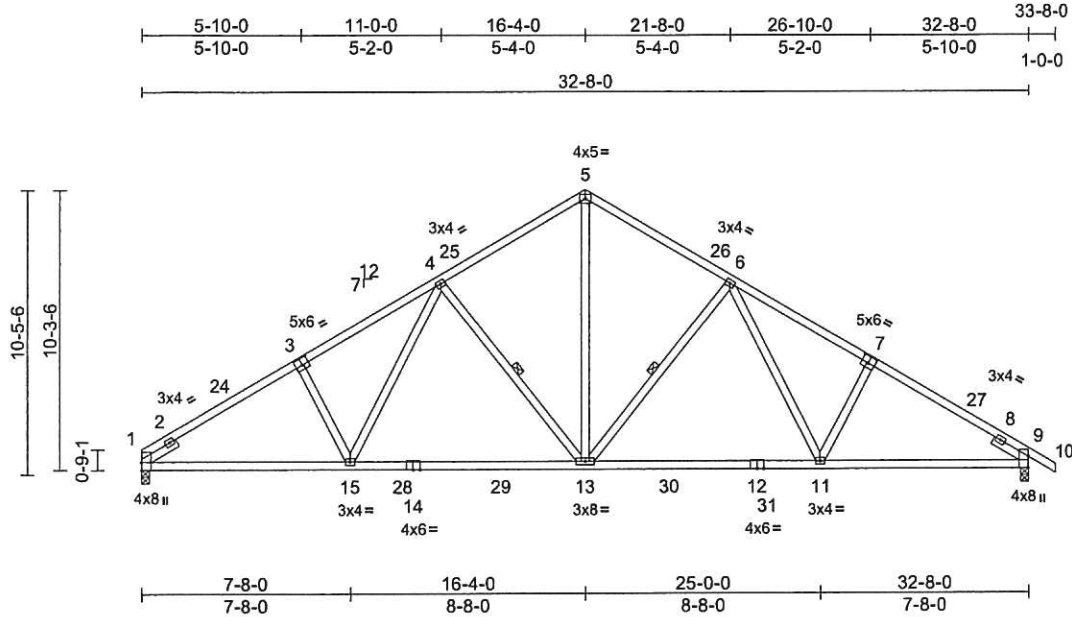

Scale = 1:84.9

Plate Offsets (X, Y): [1:0-3-8,Edge], [3:0-3-0,0-3-0], [7:0-3-0,0-3-0], [9:0-5-0,Edge]

Loading	(psf)	Spacing	2-0-0	CSI	DEFL	in	(loc)	l/defl	L/d	PLATES	GRIP	
TCLL (roof)	20.0	Plate Grip DOL	1.25	TC	0.90	Vert(LL)	-0.26	11-13	>999	240	MT20	244/190
TCDL	10.0	Lumber DOL	1.25	BC	0.99	Vert(CT)	-0.45	11-13	>871	180		
BCLL	0.0*	Rep Stress Incr	YES	WB	0.51	Horz(CT)	0.11	9	n/a	n/a		
BCDL	10.0	Code	FBC2023/TPI2014	Matrix-MS							Weight: 184 lb	FT = 20%

LUMBER

TOP CHORD 2x4 SP No.2
 BOT CHORD 2x4 SP No.2
 WEBS 2x4 SP No.3
 SLIDER Left 2x4 SP No.3 – 1-6-0, Right 2x4 SP No.3 – 1-6-0

BRACING

TOP CHORD Structural wood sheathing directly applied or 2-2-0 oc purlins.
 BOT CHORD Rigid ceiling directly applied or 2-2-0 oc bracing, Except:
 8-7-12 oc bracing: 1-15.
 WEBS 1 Row at midpt 4-13, 6-13

REACTIONS

(size) 1=0-3-8, 9=0-3-8
 Max Horiz 1=-245 (LC 8)
 Max Uplift 1=-302 (LC 12), 9=-327 (LC 13)
 Max Grav 1=1508 (LC 19), 9=1566 (LC 20)

FORCES

(lb) - Maximum Compression/Maximum Tension
 TOP CHORD 1-4=-2268/499, 4-5=-1543/393, 5-6=-1544/393, 6-9=-2263/497, 9-10=0/30
 BOT CHORD 1-15=-465/2050, 13-15=-323/1729, 11-13=-215/1608, 9-11=-294/1856
 WEBS 4-15=-137/523, 3-15=-216/190, 4-13=-629/291, 5-13=-267/1224, 6-13=-627/290, 6-11=-135/518, 7-11=-212/189

NOTES

- Unbalanced roof live loads have been considered for this design.
- Wind: ASCE 7-22; Vult=130mph (3-second gust) Vasd=101mph; TCDL=4.2psf; BCDL=3.0psf; h=18ft; Cat. II; Exp B; Enclosed; MWFRS (envelope) exterior (2) zone and C-C Zone3 0-0-0 to 3-3-3, Zone1 3-3-3 to 16-4-0, Zone2 16-4-0 to 20-11-7, Zone1 20-11-7 to 33-8-0 zone; C-C for members and forces & MWFRS for reactions shown; Lumber DOL=1.60 plate grip DOL=1.60

- Building Designer / Project engineer responsible for verifying applied roof live load shown covers rain loading requirements specific to the use of this truss component.
- This truss has been designed for a 10.0 psf bottom chord live load nonconcurrent with any other live loads.
- * This truss has been designed for a live load of 20.0psf on the bottom chord in all areas where a rectangle 3-06-00 tall by 2-00-00 wide will fit between the bottom chord and any other members, with BCDL = 10.0psf.
- Provide mechanical connection (by others) of truss to bearing plate capable of withstanding 302 lb uplift at joint 1 and 327 lb uplift at joint 9.

LOAD CASE(S) Standard

This item has been digitally signed and sealed by O'Regan, Philip, PE on the date indicated here. Printed copies of this document are not considered signed and sealed and the signature must be verified on any electronic copies.

Philip J. O'Regan PE No.59126
 MiTek Inc. DBA MiTek USA FL Cert 6634
 16023 Swingley Ridge Rd. Chesterfield, MO 63017
 Date:

February 23, 2026

WARNING - Verify design parameters and READ NOTES ON THIS AND INCLUDED MITEK REFERENCE PAGE MII-7473 rev. 1/2/2023 BEFORE USE.

Design valid for use only with MiTek® connectors. This design is based only upon parameters shown, and is for an individual building component, not a truss system. Before use, the building designer must verify the applicability of design parameters and properly incorporate this design into the overall building design. Bracing indicated is to prevent buckling of individual truss web and/or chord members only. Additional temporary and permanent bracing is always required for stability and to prevent collapse with possible personal injury and property damage. For general guidance regarding the fabrication, storage, delivery, erection and bracing of trusses and truss systems, see ANSI/TP1 Quality Criteria and DSB-22 available from Truss Plate Institute (www.tpinst.org) and BCSI Building Component Safety Information available from the Structural Building Component Association (www.sbcscomponents.com)

MiTek®
 16023 Swingley Ridge Rd.
 Chesterfield, MO 63017
 314.434.1200 / MiTek-US.com

Job 5263975	Truss T03	Truss Type Attic	Qty 3	Ply 1	Job Reference (optional) T40209557
----------------	--------------	---------------------	----------	----------	---------------------------------------

Builders FirstSource (Lake City,FL), Lake City, FL - 32055,

Run: 8.83 S Jan 22 2026 Print: 8.830 S Jan 22 2026 MiTek Industries, Inc. Fri Feb 20 08:24:08
ID:YLgQQA6dPqPqJFydzWfgyZzjvF-RfC?PsB70Hq3NSgPqnL0w3ulTXbGKwRCDoI7J4zJC?I

Page: 1

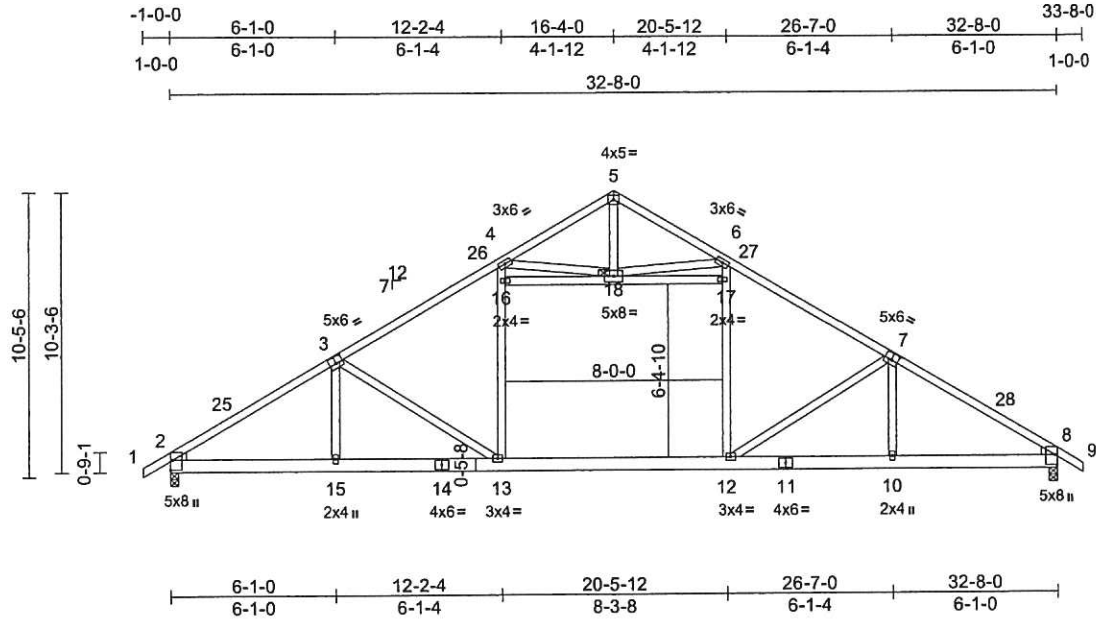

Scale = 1:84.9
Plate Offsets (X, Y): [2:Edge,0-0-14], [3:0-3-0,0-3-0], [7:0-3-0,0-3-0], [8:Edge,0-0-14]

Loading	(psf)	Spacing	2-0-0	CSI	DEFL	in	(loc)	l/defl	L/d	PLATES	GRIP
TCLL (roof)	20.0	Plate Grip DOL	1.25	TC	Vert(LL)	-0.26	10-12	>999	240	MT20	244/190
TCDL	10.0	Lumber DOL	1.25	BC	Vert(CT)	-0.35	10-12	>999	180		
BCLL	0.0*	Rep Stress Incr	YES	WB	Horz(CT)	0.07	8	n/a	n/a		
BCDL	10.0	Code	FBC2023/TPI2014	Matrix-MS	Attic	-0.21	12-13	>470	360	Weight: 218 lb	FT = 20%

LUMBER
TOP CHORD 2x4 SP No.2
BOT CHORD 2x6 SP No.2
WEBS 2x4 SP No.3
WEDGE Left: 2x4 SP No.3
Right: 2x4 SP No.3

BRACING
TOP CHORD Structural wood sheathing directly applied or 3-5-11 oc purlins.
BOT CHORD Rigid ceiling directly applied or 10-0-0 oc bracing, Except:
2-2-0 oc bracing: 12-13.

JOINTS
1 Brace at Jt(s): 18

REACTIONS (size) 2=0-3-8, 8=0-3-8
Max Horiz 2=-250 (LC 10)
Max Uplift 2=-253 (LC 12), 8=-253 (LC 13)
Max Grav 2=1640 (LC 20), 8=1640 (LC 21)

FORCES (lb) - Maximum Compression/Maximum Tension
TOP CHORD 1-2=0/30, 2-4=-2495/351, 4-5=-611/75, 5-6=-611/75, 6-8=-2496/352, 8-9=0/30
BOT CHORD 2-15=-373/2257, 13-15=-373/2256, 12-13=-115/1961, 10-12=-205/2070, 8-10=-205/2070
WEBS 12-17=-35/658, 6-17=-23/698, 13-16=-35/658, 4-16=-24/698, 16-18=-200/164, 17-18=-200/164, 5-18=-9/378, 4-18=-1509/356, 6-18=-1509/356, 3-15=-140/161, 3-13=-451/295, 7-10=-141/161, 7-12=-451/295

- Wind: ASCE 7-22; Vult=130mph (3-second gust) Vasd=101mph; TCDL=4.2psf; BCDL=3.0psf; h=18ft; Cat. II; Exp B; Enclosed; MWFRS (envelope) exterior (2) zone and C-C Zone3 -1-0-0 to 2-3-3, Zone1 2-3-3 to 16-4-0, Zone2 16-4-0 to 20-11-7, Zone1 20-11-7 to 33-8-0 zone;C-C for members and forces & MWFRS for reactions shown; Lumber DOL=1.60 plate grip DOL=1.60
 - Building Designer / Project engineer responsible for verifying applied roof live load shown covers rain loading requirements specific to the use of this truss component.
 - This truss has been designed for a 10.0 psf bottom chord live load nonconcurrent with any other live loads.
 - * This truss has been designed for a live load of 20.0psf on the bottom chord in all areas where a rectangle 3-06-00 tall by 2-00-00 wide will fit between the bottom chord and any other members.
 - Ceiling dead load (10.0 psf) on member(s). 16-18, 17-18
 - Bottom chord live load (40.0 psf) and additional bottom chord dead load (5.0 psf) applied only to room. 12-13
 - Provide mechanical connection (by others) of truss to bearing plate capable of withstanding 253 lb uplift at joint 8 and 253 lb uplift at joint 2.
 - ATTIC SPACE SHOWN IS DESIGNED AS UNINHABITABLE.
- LOAD CASE(S)** Standard

This item has been digitally signed and sealed by O'Regan, Philip, PE on the date indicated here. Printed copies of this document are not considered signed and sealed and the signature must be verified on any electronic copies.

Philip J. O'Regan PE No.55126
MiTek Inc. DBA MiTek USA FL Cert 6634
16023 Swingley Ridge Rd. Chesterfield, MO 63017
Date:

February 23, 2026

WARNING - Verify design parameters and READ NOTES ON THIS AND INCLUDED MITEK REFERENCE PAGE MII-747.3 rev. 1/2/2023 BEFORE USE.
Design valid for use only with MiTek® connectors. This design is based only upon parameters shown, and is for an individual building component, not a truss system. Before use, the building designer must verify the applicability of design parameters and properly incorporate this design into the overall building design. Bracing indicated is to prevent buckling of individual truss web and/or chord members only. Additional temporary and permanent bracing is always required for stability and to prevent collapse with possible personal injury and property damage. For general guidance regarding the fabrication, storage, delivery, erection and bracing of trusses and truss systems, see **ANSI/TPI Quality Criteria and DSB-22** available from Truss Plate Institute (www.tpinst.org) and **BCSI Building Component Safety Information** available from the Structural Building Component Association (www.sbcscomponents.com)

MiTek®
16023 Swingley Ridge Rd.
Chesterfield, MO 63017
314.434.1200 / MiTek-US.com

Job 5263975	Truss T04	Truss Type Roof Special	Qty 4	Ply 1	Job Reference (optional)	T40209558
----------------	--------------	----------------------------	----------	----------	--------------------------	-----------

Builders FirstSource (Lake City,FL), Lake City, FL - 32055,

Run: 8.83 S Jan 22 2026 Print: 8.830 S Jan 22 2026 MiTek Industries, Inc. Fri Feb 20 08:24:08
ID:dtBBZW2MaA0AdE9nRx8W6hzjQI-RFC7PsB70Hq3NSgPqnL8w3uITXbGKwRcDoi7J4zJC7f

Page: 1

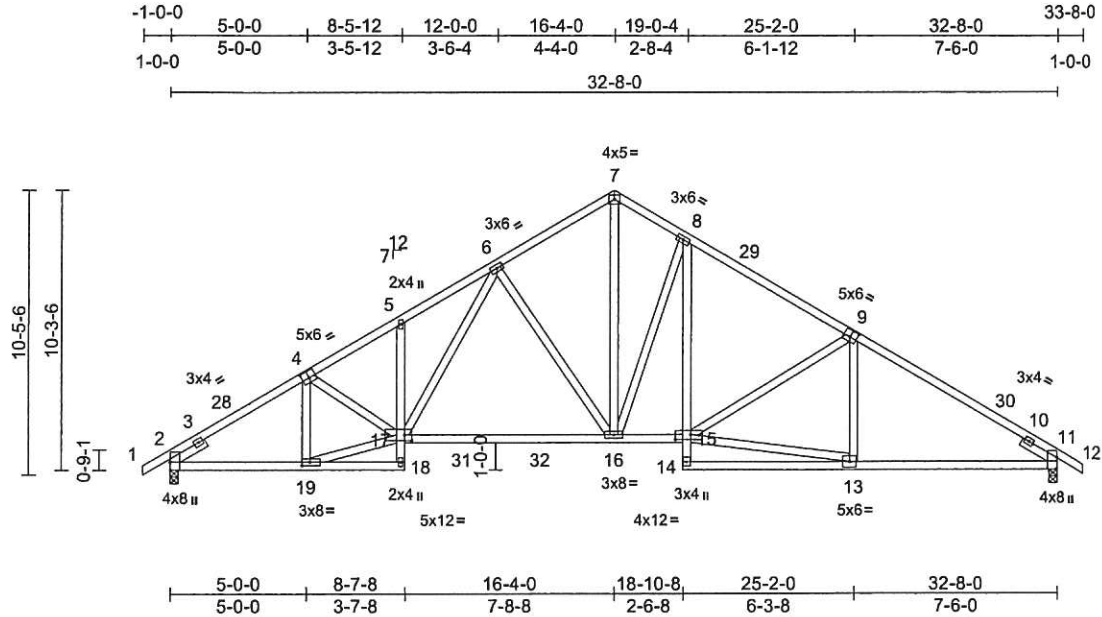

Scale = 1:84.9

Plate Offsets (X, Y): [2:0-3-8,Edge], [4:0-3-0,0-3-0], [9:0-3-0,0-3-0], [11:0-5-0,Edge], [15:0-6-12,0-2-4], [17:0-3-4,0-2-8], [19:0-3-8,0-1-8]

Loading	(psf)	Spacing	2-0-0	CSI	DEFLL	in	(loc)	l/defl	L/d	PLATES	GRIP	
TCLL (roof)	20.0	Plate Grip DOL	1.25	TC	0.95	Ver(LL)	-0.25	16-17	>999	240	MT20	244/190
TCDL	10.0	Lumber DOL	1.25	BC	0.92	Horz(CT)	-0.45	16-17	>863	180		
BCLL	0.0*	Rep Stress Incr	YES	WB	0.83	Horz(CT)	0.13	11	n/a	n/a		
BCDL	10.0	Code	FBC2023/TPI2014	Matrix-MS							Weight: 220 lb	FT = 20%

LUMBER

TOP CHORD 2x4 SP No.2
 BOT CHORD 2x4 SP No.2 *Except* 18-5,8-14:2x4 SP No.3
 WEBS 2x4 SP No.3
 SLIDER Left 2x4 SP No.3 - 1-6-0, Right 2x4 SP No.3 - 1-6-0

BRACING

TOP CHORD Structural wood sheathing directly applied.
 BOT CHORD Rigid ceiling directly applied or 2-2-0 oc bracing.

REACTIONS

(size) 2=0-3-8, 11=0-3-8
 Max Horiz 2=-250 (LC 10)
 Max Uplift 2=-327 (LC 12), 11=-327 (LC 13)
 Max Grav 2=1539 (LC 19), 11=1527 (LC 20)

FORCES

(lb) - Maximum Compression/Maximum Tension
 TOP CHORD 1-2=0/30, 2-5=-2513/546, 5-6=-2567/626, 6-7=-1614/396, 7-8=-1614/425, 8-11=-2162/446, 11-12=0/30
 BOT CHORD 2-19=-467/1993, 18-19=-35/59, 17-18=0/91, 5-17=-239/131, 16-17=-331/1848, 15-16=-203/1609, 14-15=0/115, 8-15=-145/485, 13-14=-3/189, 11-13=-265/1763
 WEBS 4-17=0/359, 8-16=-686/297, 13-15=-270/1601, 9-15=-350/225, 9-13=-137/87, 7-16=-339/1415, 6-16=-731/306, 6-17=-267/952, 4-19=-524/160, 17-19=-451/2049

NOTES

1) Unbalanced roof live loads have been considered for this design.

- 2) Wind: ASCE 7-22; Vult=130mph (3-second gust) Vasd=101mph; TCDL=4.2psf; BCDL=3.0psf; h=18ft; Cat. II; Exp B; Enclosed; MWFRS (envelope) exterior (2) zone and C-C Zone3 -1-0-0 to 2-3-3, Zone1 2-3-3 to 16-4-0, Zone2 16-4-0 to 20-11-7, Zone1 20-11-7 to 33-8-0 zone;C-C for members and forces & MWFRS for reactions shown; Lumber DOL=1.60 plate grip DOL=1.60
- 3) Building Designer / Project engineer responsible for verifying applied roof live load shown covers rain loading requirements specific to the use of this truss component.
- 4) This truss has been designed for a 10.0 psf bottom chord live load nonconcurrent with any other live loads.
- 5) * This truss has been designed for a live load of 20.0psf on the bottom chord in all areas where a rectangle 3-06-00 tall by 2-00-00 wide will fit between the bottom chord and any other members, with BCDL = 10.0psf.
- 6) Provide mechanical connection (by others) of truss to bearing plate capable of withstanding 327 lb uplift at joint 2 and 327 lb uplift at joint 11.

LOAD CASE(S) Standard

This item has been digitally signed and sealed by ORegan, Philip, PE on the date indicated here. Printed copies of this document are not considered signed and sealed and the signature must be verified on any electronic copies.

Philip J. O'Regan PE No.58126
 MiTek Inc. DBA MiTek USA FL Cert 6634
 16023 Swingley Ridge Rd. Chesterfield, MO 63017
 Date:

February 23,2026

WARNING - Verify design parameters and READ NOTES ON THIS AND INCLUDED MITEK REFERENCE PAGE MII-7473 rev. 1/2/2023 BEFORE USE.

Design valid for use only with MiTek® connectors. This design is based only upon parameters shown, and is for an individual building component, not a truss system. Before use, the building designer must verify the applicability of design parameters and properly incorporate this design into the overall building design. Bracing indicated is to prevent buckling of individual truss web and/or chord members only. Additional temporary and permanent bracing is always required for stability and to prevent collapse with possible personal injury and property damage. For general guidance regarding the fabrication, storage, delivery, erection and bracing of trusses and truss systems, see ANSI/TPI1 Quality Criteria and DSB-22 available from Truss Plate Institute (www.tpinstitute.org) and BCSI Building Component Safety Information available from the Structural Building Component Association (www.sbcsc.com)

MiTek®
 16023 Swingley Ridge Rd.
 Chesterfield, MO 63017
 314.434.1200 / MiTek-US.com

Job 5263975	Truss T05	Truss Type Roof Special	Qty 2	Ply 1	Job Reference (optional)	T40209559
----------------	--------------	----------------------------	----------	----------	--------------------------	-----------

Builders FirstSource (Lake City,FL), Lake City, FL - 32055,

Run: 8.83 S Jan 22 2026 Print: 8.830 S Jan 22 2026 MITek Industries, Inc. Fri Feb 20 08:24:09
ID:Xpf6xOkAcBfllQlshLfmnCzjOZ-RfC?PsB70Hq3NSgPqnL8w3uITXbGKWrCdoi7J4zJC?l

Page: 1

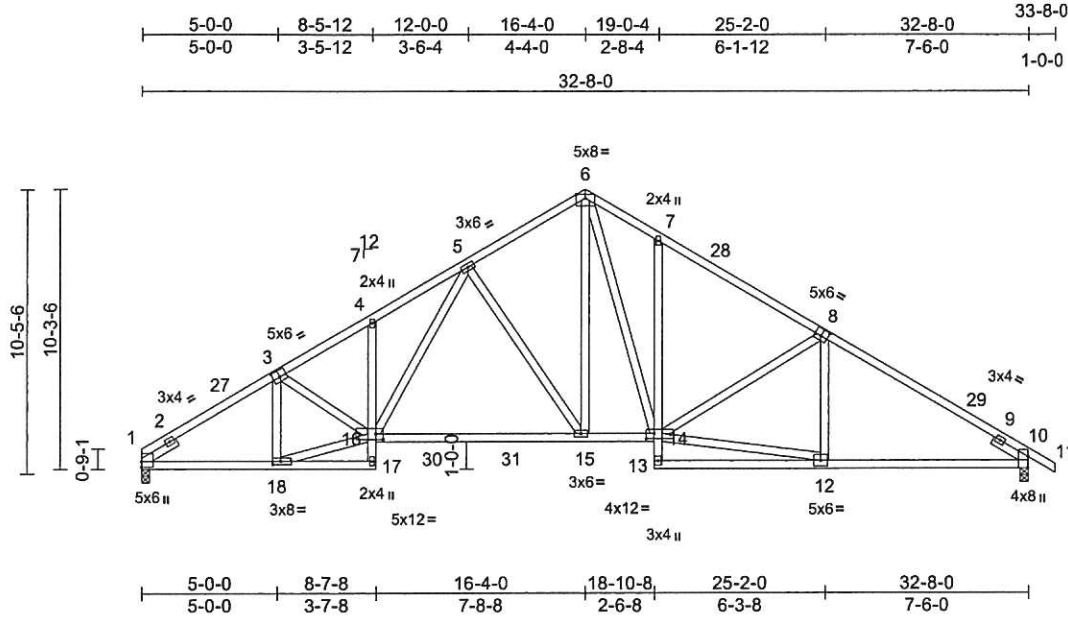

Scale = 1:84.9

Plate Offsets (X, Y): [3:0-3-0,0-3-0], [8:0-3-0,0-3-0], [10:0-5-0,Edge], [14:0-3-8,0-2-4], [16:0-3-4,0-2-8], [18:0-3-8,0-1-8]

Loading	(psf)	Spacing	2-0-0	CSI	DEFLL	in	(loc)	l/defl	L/d	PLATES	GRIP	
TCLL (roof)	20.0	Plate Grip DOL	1.25	TC	0.95	Vert(LL)	-0.24	15-16	>999	240	MT20	244/190
TCDL	10.0	Lumber DOL	1.25	BC	0.90	Vert(CT)	-0.45	15-16	>870	180		
BCLL	0.0*	Rep Stress Incr	YES	WB	0.84	Horz(CT)	0.12	10	n/a	n/a		
BCDL	10.0	Code	FBC2023/TPI2014	Matrix-MS							Weight: 220 lb	FT = 20%

LUMBER

TOP CHORD 2x4 SP No.2
 BOT CHORD 2x4 SP No.2 *Except* 17-4,7-13:2x4 SP No.3
 WEBS 2x4 SP No.3
 SLIDER Left 2x4 SP No.3 - 1-6-0, Right 2x4 SP No.3 - 1-6-0

BRACING

TOP CHORD Structural wood sheathing directly applied.
 BOT CHORD Rigid ceiling directly applied or 6-0-0 oc bracing.

REACTIONS

(size) 1=0-3-8, 10=0-3-8
 Max Horiz 1=-245 (LC 8)
 Max Uplift 1=-302 (LC 12), 10=-327 (LC 13)
 Max Grav 1=1481 (LC 19), 10=1528 (LC 20)

FORCES

(lb) - Maximum Compression/Maximum Tension
 TOP CHORD 1-4=-2519/548, 4-5=-2571/628, 5-6=-1615/397, 6-7=-1852/510, 7-10=-2163/446, 10-11=0/30
 BOT CHORD 1-18=-470/2003, 17-18=-34/57, 16-17=0/90, 4-16=-235/130, 15-16=-332/1851, 14-15=-160/1440, 13-14=0/115, 7-14=-297/190, 12-13=-2/182, 10-12=-265/1764
 WEBS 6-14=-348/809, 12-14=-270/1605, 8-14=-351/225, 8-12=-133/86, 6-15=-215/948, 5-15=-736/308, 5-16=-268/955, 3-16=0/353, 3-18=-523/159, 16-18=-455/2061

NOTES

1) Unbalanced roof live loads have been considered for this design.

- 2) Wind: ASCE 7-22; Vult=130mph (3-second gust) Vasd=101mph; TCDL=4.2psf; BCDL=3.0psf; h=18ft; Cat. II; Exp B; Enclosed; MWFRS (envelope) exterior (2) zone and C-C Zone3 0-0-0 to 3-3-3, Zone1 3-3-3 to 16-4-0, Zone2 16-4-0 to 20-11-7, Zone1 20-11-7 to 33-8-0 zone;C-C for members and forces & MWFRS for reactions shown; Lumber DOL=1.60 plate grip DOL=1.60
- 3) Building Designer / Project engineer responsible for verifying applied roof live load shown covers rain loading requirements specific to the use of this truss component.
- 4) This truss has been designed for a 10.0 psf bottom chord live load nonconcurrent with any other live loads.
- 5) * This truss has been designed for a live load of 20.0psf on the bottom chord in all areas where a rectangle 3-06-00 tall by 2-00-00 wide will fit between the bottom chord and any other members, with BCDL = 10.0psf.
- 6) Provide mechanical connection (by others) of truss to bearing plate capable of withstanding 302 lb uplift at joint 1 and 327 lb uplift at joint 10.

LOAD CASE(S) Standard

This item has been digitally signed and sealed by ORegan, Philip, PE on the date indicated here. Printed copies of this document are not considered signed and sealed and the signature must be verified on any electronic copies.

Philip J. O'Regan PE No.59126
 MITek Inc. DBA MITek USA FL Cert 6634
 16023 Swingley Ridge Rd. Chesterfield, MO 63017
 Date:

February 23,2026

WARNING - Verify design parameters and READ NOTES ON THIS AND INCLUDED MITEK REFERENCE PAGE MII-747J rev. 1/2/2023 BEFORE USE.

Design valid for use only with MITek® connectors. This design is based only upon parameters shown, and is for an individual building component, not a truss system. Before use, the building designer must verify the applicability of design parameters and properly incorporate this design into the overall building design. Bracing indicated is to prevent buckling of individual truss web and/or chord members only. Additional temporary and permanent bracing is always required for stability and to prevent collapse with possible personal injury and property damage. For general guidance regarding the fabrication, storage, delivery, erection and bracing of trusses and truss systems, see **ANSI/TPI1 Quality Criteria and DSB-22** available from Truss Plate Institute (www.tpinstitute.org) and **BCSI Building Component Safety Information** available from the Structural Building Component Association (www.sbcsccomponents.com)

MiTek®
 16023 Swingley Ridge Rd.
 Chesterfield, MO 63017
 314.434.1200 / MITek-US.com

Job 5263975	Truss T06	Truss Type Attic	Qty 2	Ply 1	Job Reference (optional) T40209560
----------------	--------------	---------------------	----------	----------	---------------------------------------

Builders FirstSource (Lake City,FL), Lake City, FL - 32055,

Run: 8.83 S Jan 22 2026 Print: 8.830 S Jan 22 2026 MITek Industries, Inc. Fri Feb 20 08:24:09

Page: 1

ID:4uVGD?KXhjhkBZNZZJEXWzjt8J-RfC7PsB70Hq3NSgPqnL8w3uITXbGKWrCDol7J4zJC7f

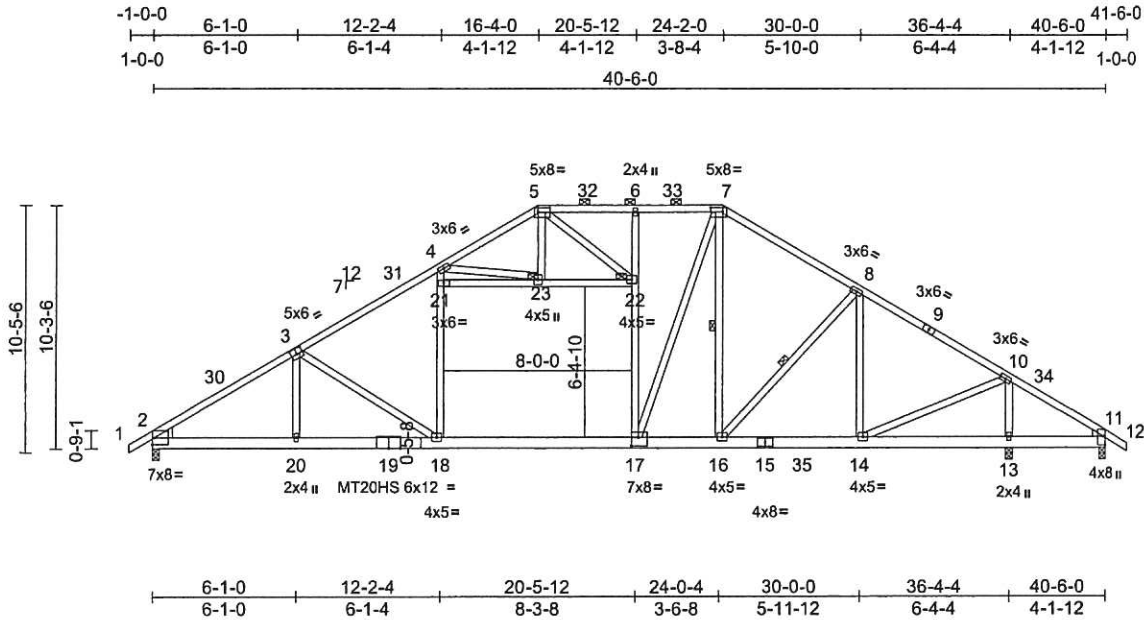

Scale = 1:97.8

Plate Offsets (X, Y): [3:0-3-0,0-3-0], [5:0-6-0,0-2-4], [7:0-6-0,0-2-4], [11:Edge,0-0-14], [17:0-3-8,0-4-8]

Loading	(psf)	Spacing	2-2-0	CSI	DEFL	in	(loc)	l/defl	L/d	PLATES	GRIP	
TCLL (roof)	20.0	Plate Grip DOL	1.25	TC	0.86	Vert(LL)	-0.53	18-20	>820	240	244/190	
TCDL	10.0	Lumber DOL	1.25	BC	0.96	Vert(CT)	-0.95	18-20	>459	180	MT20HS	187/143
BCLL	0.0*	Rep Stress Incr	NO	WB	0.85	Horz(CT)	0.07	11	n/a	n/a		
BCDL	10.0	Code	FBC2023/TPI2014	Matrix-MS	Attic		-0.29	17-18	>347	360	Weight: 303 lb	FT = 20%

LUMBER
TOP CHORD 2x4 SP No.2 *Except* 3-5:2x4 SP No.1
BOT CHORD 2x6 SP 2400F 2.0E or 2x6 SP M 26 *Except* 15-11:2x6 SP No.2
WEBS 2x4 SP No.3 *Except* 4-18:2x4 SP No.1, 6-17,16-7:2x4 SP No.2
WEDGE Left: 2x6 SP No.2
Right: 2x4 SP No.3

BRACING
TOP CHORD Structural wood sheathing directly applied or 2-7-9 oc purlins, except 2-0-0 oc purlins (3-1-12 max.): 5-7.
BOT CHORD Rigid ceiling directly applied or 10-0-0 oc bracing, Except: 9-9-4 oc bracing: 17-18
8-5-2 oc bracing: 16-17.
WEBS 1 Row at midpt 7-16, 8-16
JOINTS 1 Brace at Jt(s): 22, 23

REACTIONS (size) 2=0-3-8, 11=0-3-8, 13=0-3-8
Max Horiz 2=-271 (LC 10)
Max Uplift 2=-352 (LC 12), 11=-240 (LC 12), 13=-392 (LC 13)
Max Grav 2=2206 (LC 20), 11=811 (LC 20), 13=1849 (LC 29)

FORCES (lb) - Maximum Compression/Maximum Tension
TOP CHORD 1-2=0/33, 2-4=-3480/532, 4-5=-1840/316, 5-6=-2226/410, 6-7=-2307/437, 7-8=-2261/390, 8-10=-2360/397, 10-11=-1168/383, 11-12=0/33
BOT CHORD 2-20=-535/3119, 18-20=-535/3123, 17-18=-213/2407, 16-17=-122/1877, 14-16=-221/2008, 13-14=-284/989, 11-13=-284/989

WEBS 18-21=-2/495, 4-21=0/498, 17-22=-161/193, 6-22=-382/168, 7-17=-225/1387, 7-16=-342/112, 8-16=-235/179, 21-23=-187/672, 22-23=-777/142, 3-20=-69/336, 3-18=-772/361, 8-14=-367/154, 10-14=-186/1450, 10-13=-1644/402, 5-23=-4/244, 5-22=-168/822, 4-23=-1458/324

- NOTES**
- Unbalanced roof live loads have been considered for this design.
 - Wind: ASCE 7-22; Vult=130mph (3-second gust) Vasd=101mph; TCDL=4.2psf; BCDL=3.0psf; h=18ft; Cat. II; Exp B; Enclosed; MWFRS (envelope) exterior (2) zone and C-C Zone3 -1-0-0 to 3-0-10, Zone1 3-0-10 to 16-4-0, Zone2 16-4-0 to 22-0-12, Zone1 22-0-12 to 24-2-0, Zone2 24-2-0 to 30-0-0, Zone1 30-0-0 to 41-6-0 zone; porch right exposed; C-C for members and forces & MWFRS for reactions shown; Lumber DOL=1.60 plate grip DOL=1.60
 - Building Designer / Project engineer responsible for verifying applied roof live load shown covers rain loading requirements specific to the use of this truss component.
 - Provide adequate drainage to prevent water ponding.
 - All plates are MT20 plates unless otherwise indicated.
 - This truss has been designed for a 10.0 psf bottom chord live load nonconcurrent with any other live loads.
 - * This truss has been designed for a live load of 20.0psf on the bottom chord in all areas where a rectangle 3-06-00 tall by 2-00-00 wide will fit between the bottom chord and any other members, with BCDL = 10.0psf.
 - Ceiling dead load (10.0 psf) on member(s). 21-23, 22-23
 - Bottom chord live load (40.0 psf) and additional bottom chord dead load (5.0 psf) applied only to room. 17-18
 - Provide mechanical connection (by others) of truss to bearing plate capable of withstanding 240 lb uplift at joint 11, 352 lb uplift at joint 2 and 392 lb uplift at joint 13.

11) Graphical purlin representation does not depict the size or the orientation of the purlin along the top and/or bottom chord.
12) ATTIC SPACE SHOWN IS DESIGNED AS UNINHABITABLE.
LOAD CASE(S) Standard

This item has been digitally signed and sealed by O'Regan, Philip, PE on the date indicated here. Printed copies of this document are not considered signed and sealed and the signature must be verified on any electronic copies.

Philip J. O'Regan PE No.59126
MITek Inc. DBA MITek USA FL Cert 6634
16023 Swingley Ridge Rd. Chesterfield, MO 63017
Date:

February 23, 2026

WARNING - Verify design parameters and READ NOTES ON THIS AND INCLUDED MITEK REFERENCE PAGE MII-7473 rev. 1/2/2023 BEFORE USE.

Design valid for use only with MITek® connectors. This design is based only upon parameters shown, and is for an individual building component, not a truss system. Before use, the building designer must verify the applicability of design parameters and properly incorporate this design into the overall building design. Bracing indicated is to prevent buckling of individual truss web and/or chord members only. Additional temporary and permanent bracing is always required for stability and to prevent collapse with possible personal injury and property damage. For general guidance regarding the fabrication, storage, delivery, erection and bracing of trusses and truss systems, see ANSI/TPI1 Quality Criteria and DSB-22 available from Truss Plate Institute (www.tpinst.org) and BCSI Building Component Safety Information available from the Structural Building Component Association (www.sbcscomponents.com)

MiTek®
16023 Swingley Ridge Rd.
Chesterfield, MO 63017
314.434.1200 / MITek-US.com

Job 5263975	Truss T06G	Truss Type Attic	Qty 1	Ply 1	Job Reference (optional)	T40209561
----------------	---------------	---------------------	----------	----------	--------------------------	-----------

Builders FirstSource (Lake City,FL), Lake City, FL - 32055,

Run: 8.83 S Jan 22 2026 Print: 8.830 S Jan 22 2026 MiTek Industries, Inc. Fri Feb 20 08:24:10

Page: 1

ID:uA654IT_lowjuC?Wztg9n8zjsj?7-RIC?PsB70Hq3NSgPqL6w3uITXbGKWrCDai7J4zJC7f

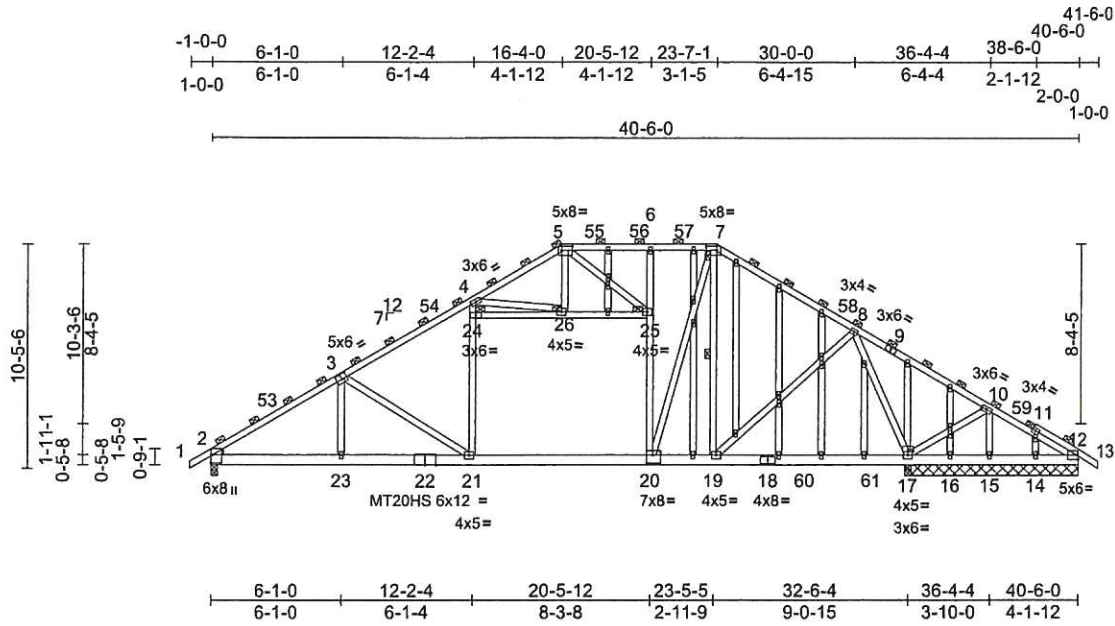

Scale = 1:107.6

Plate Offsets (X, Y): [2:Edge,0-0-14], [3:0-3-0,0-3-0], [5:0-6-0,0-2-4], [7:0-6-0,0-2-4], [17:0-3-0,0-2-0], [20:0-3-8,0-4-8]

Loading	(psf)	Spacing	2-0-0	CSI	DEFL	in	(loc)	l/defl	L/d	PLATES	GRIP
TCLL (roof)	20.0	Plate Grip DOL	1.25	TC	Vert(LL)	-0.50	21-23	>783	240	MT20	244/190
TCDL	10.0	Lumber DOL	1.25	BC	Vert(CT)	-0.95	21-23	>411	180	MT20HS	187/143
BCLL	0.0*	Rep Stress Incr	YES	WB	Horz(CT)	0.06	12	n/a	n/a		
BCDL	10.0	Code	FBC2023/TPI2014	Matrix-MS	Attic	-0.27	20-21	>370	360	Weight: 371 lb	FT = 20%

LUMBER
TOP CHORD 2x4 SP No.2
BOT CHORD 2x6 SP 2400F 2.0E or 2x6 SP M 26 *Except*
18-12:2x6 SP No.2
WEBS
2x4 SP No.3 *Except* 4-21:2x4 SP No.1,
6-20,19-7:2x4 SP No.2
OTHERS
2x4 SP No.3
WEDGE
Left: 2x4 SP No.3

WEBS
21-24=0/521, 4-24=0/505, 20-25=-150/206,
6-25=-354/143, 7-20=-96/1429,
7-19=-424/17, 8-19=-124/260,
8-17=-984/376, 10-17=-154/935,
24-26=-132/659, 25-26=-792/73,
4-26=-1460/203, 3-23=-57/320,
3-21=-720/322, 5-26=-1/182, 5-25=-54/811,
10-15=-1193/275

12) Bottom chord live load (40.0 psf) and additional bottom chord dead load (10.0 psf) applied only to room. 20-21
13) Provide mechanical connection (by others) of truss to bearing plate capable of withstanding 263 lb uplift at joint 2, 495 lb uplift at joint 17, 255 lb uplift at joint 15, 19 lb uplift at joint 14, 201 lb uplift at joint 16, 134 lb uplift at joint 12 and 134 lb uplift at joint 12.
14) Graphical purlin representation does not depict the size or the orientation of the purlin along the top and/or bottom chord.
15) ATTIC SPACE SHOWN IS DESIGNED AS UNINHABITABLE.
LOAD CASE(S) Standard

BRACING
TOP CHORD 2-0-0 oc purlins (2-2-0 max.).
BOT CHORD Rigid ceiling directly applied or 10-0-0 oc bracing, Except:
9-5-9 oc bracing: 20-21
8-6-8 oc bracing: 19-20.
WEBS
1 Row at midpt 7-19
JOINTS
1 Brace at Jt(s): 5,
7, 24, 25, 26

NOTES
1) Unbalanced roof live loads have been considered for this design.
2) Wind: ASCE 7-22; Vult=130mph (3-second gust) Vasd=101mph; TCDL=4.2psf; BCDL=3.0psf; h=18ft; Cat. II; Exp B; Enclosed; MWFRS (envelope) exterior (2) zone and C-C Zone3 -1-0-0 to 3-0-10, Zone1 3-0-10 to 16-4-0, Zone2 16-4-0 to 22-0-12, Zone1 22-0-12 to 23-7-1, Zone2 23-7-1 to 29-3-13, Zone1 29-3-13 to 41-6-0 zone; porch right exposed;C-C for members and forces & MWFRS for reactions shown; Lumber DOL=1.60 plate grip DOL=1.60
3) Truss designed for wind loads in the plane of the truss only. For studs exposed to wind (normal to the face), see Standard Industry Gable End Details as applicable, or consult qualified building designer as per ANSI/TPI 1.
4) Building Designer / Project engineer responsible for verifying applied roof live load shown covers rain loading requirements specific to the use of this truss component.
5) Provide adequate drainage to prevent water ponding.
6) All plates are MT20 plates unless otherwise indicated.
7) All plates are 2x4 (||) MT20 unless otherwise indicated.
8) Gable studs spaced at 2-0-0 oc.
9) This truss has been designed for a 10.0 psf bottom chord live load nonconcurrent with any other live loads.
10) * This truss has been designed for a live load of 20.0psf on the bottom chord in all areas where a rectangle 3-06-00 tall by 2-00-00 wide will fit between the bottom chord and any other members, with BCDL = 10.0psf.
11) Ceiling dead load (5.0 psf) on member(s). 24-26, 25-26; Wall dead load (5.0psf) on member(s).21-24, 20-25

REACTIONS (size) 2=0-3-8, 12=8-1-8, 14=8-1-8,
15=8-1-8, 16=8-1-8, 17=8-1-8
Max Horiz 2=-250 (LC 10)
Max Uplift 2=-263 (LC 12), 12=-134 (LC 12),
14=-19 (LC 8), 15=-255 (LC 12),
16=-201 (LC 18), 17=-495 (LC 8)
Max Grav 2=2087 (LC 20), 12=689 (LC 20),
14=50 (LC 3), 15=1340 (LC 20),
16=-14 (LC 8), 17=1028 (LC 29)

FORCES (lb) - Maximum Compression/Maximum Tension
TOP CHORD 1-2=0/30, 2-4=-3306/378, 4-5=-1650/260,
5-6=-2064/302, 6-7=-2162/321,
7-8=-2127/310, 8-10=-2001/459,
10-12=-1052/223, 12-13=0/30
BOT CHORD 2-23=-396/2960, 21-23=-396/2963,
20-21=-111/2292, 19-20=-73/1819,
17-19=-238/1843, 16-17=-162/913,
15-16=-162/913, 14-15=-162/913,
12-14=-162/913

This item has been digitally signed and sealed by O'Regan, Philip, PE on the date indicated here. Printed copies of this document are not considered signed and sealed and the signature must be verified on any electronic copies.

Philip J. O'Regan PE No.58126
MiTek Inc. DBA MiTek USA FL Cert 6634
16023 Swingley Ridge Rd. Chesterfield, MO 63017
Date:

February 23,2026

WARNING - Verify design parameters and READ NOTES ON THIS AND INCLUDED MITEK REFERENCE PAGE MII-7473 rev. 1/2/2023 BEFORE USE.

Design valid for use only with MiTek® connectors. This design is based only upon parameters shown, and is for an individual building component, not a truss system. Before use, the building designer must verify the applicability of design parameters and properly incorporate this design into the overall building design. Bracing indicated is to prevent buckling of individual truss web and/or chord members only. Additional temporary and permanent bracing is always required for stability and to prevent collapse with possible personal injury and property damage. For general guidance regarding the fabrication, storage, delivery, erection and bracing of trusses and truss systems, see ANSI/TPI1 Quality Criteria and DSB-22 available from Truss Plate Institute (www.tpinst.org) and BCSI Building Component Safety Information available from the Structural Building Component Association (www.sbcscomponents.com)

MiTek®

16023 Swingley Ridge Rd.
Chesterfield, MO 63017
314.434.1200 / MiTek-US.com

Job 5263975	Truss T07	Truss Type Piggyback Base	Qty 4	Ply 1	Job Reference (optional)	T40209562
----------------	--------------	------------------------------	----------	----------	--------------------------	-----------

Builders FirstSource (Lake City,FL), Lake City, FL - 32055,

Run: 8.83 S Jan 22 2026 Print: 8.830 S Jan 22 2026 MITek Industries, Inc. Fri Feb 20 08:24:10
ID:YzIWUuNUazo?keGqcv5FluzjiMR-RIC?PsB70Hq3NSgPqnL8w3uITXbGKWrCDol7J4zJC?!

Page: 1

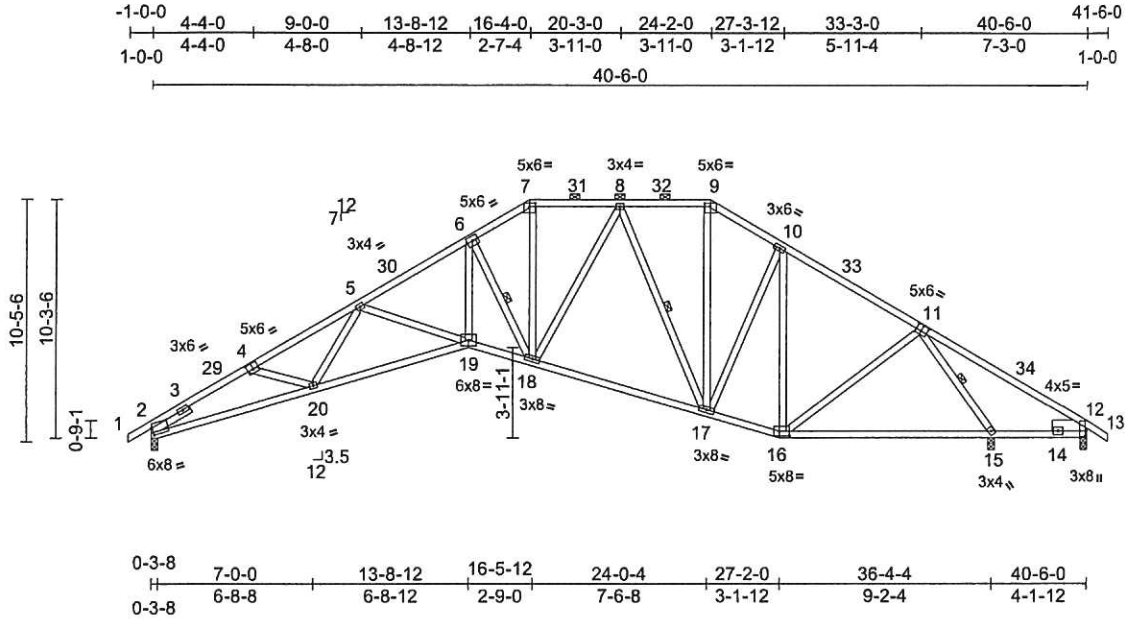

Scale = 1:99.7

Plate Offsets (X, Y): [2:0-0-11,0-3-12], [4:0-3-0,0-3-0], [7:0-3-0,0-1-12], [9:0-3-0,0-1-12], [11:0-2-12,0-3-4], [12:0-2-13,0-0-11], [16:0-5-4,0-2-8]

Loading	(psf)	Spacing	2-0-0	CSI	DEFL	in	(loc)	l/defl	L/d	PLATES	GRIP	
TCLL (roof)	20.0	Plate Grip DOL	1.25	TC	0.81	Vert(LL)	-0.29	19-20	>999	240	MT20	244/190
TCDL	10.0	Lumber DOL	1.25	BC	0.92	Vert(CT)	-0.61	19-20	>719	180		
BCLL	0.0*	Rep Stress Incr	YES	WB	0.81	Horz(CT)	0.34	15	n/a	n/a		
BCDL	10.0	Code	FBC2023/TPI2014	Matrix-MS								
											Weight: 263 lb	FT = 20%

LUMBER
TOP CHORD 2x4 SP No.2 *Except* 4-1:2x4 SP 2700F
2.2E or 2x4 SP 2850F 2.0E or 2x4 SP M 31
BOT CHORD 2x4 SP No.2 *Except* 2-19:2x4 SP No.1
WEBS 2x4 SP No.3
SLIDER Left 2x4 SP No.3 - 2-0-0, Right 2x6 SP No.2
- 1-6-0

BRACING
TOP CHORD Structural wood sheathing directly applied or
2-2-0 oc purlins, except
2-0-0 oc purlins (4-4-0 max.): 7-9.
BOT CHORD Rigid ceiling directly applied or 2-2-0 oc
bracing.
WEBS 1 Row at midpt 6-18, 11-15, 8-17
REACTIONS (size) 2=0-3-8, 12=0-3-8, 15=0-3-8
Max Horiz 2=-250 (LC 10)
Max Uplift 2=-370 (LC 12), 12=-598 (LC 25),
15=-399 (LC 12)
Max Grav 2=1446 (LC 1), 12=94 (LC 12),
15=2347 (LC 1)

FORCES (lb) - Maximum Compression/Maximum
Tension
TOP CHORD 1-2=0/30, 2-5=-3444/972, 5-6=-3033/787,
6-7=-2057/586, 7-8=-1755/529,
8-9=-1132/426, 9-10=-1365/469,
10-12=-1268/1171, 12-13=0/30
BOT CHORD 2-20=-936/2943, 19-20=-849/3088,
18-19=-587/2651, 17-18=-244/1544,
16-17=-123/1048, 15-16=-192/483,
12-15=-950/444
WEBS 6-19=-476/1833, 6-18=-1758/552,
7-18=-208/839, 9-17=-159/487,
10-17=-170/426, 10-16=-637/127,
11-16=-133/761, 11-15=-2390/484,
4-20=-34/180, 5-20=-22/174, 5-19=-485/265,
8-17=-884/271, 8-18=-170/672

NOTES

- Unbalanced roof live loads have been considered for this design.
- Wind: ASCE 7-22; Vult=130mph (3-second gust)
Vasd=101mph; TCDL=4.2psf; BCDL=3.0psf; h=18ft; Cat. II; Exp B; Enclosed; MWFRS (envelope) exterior (2) zone and C-C Zone3 -1-0-0 to 3-0-10, Zone1 3-0-10 to 16-4-0, Zone2 16-4-0 to 22-0-12, Zone1 22-0-12 to 24-2-0, Zone2 24-2-0 to 29-10-12, Zone1 29-10-12 to 41-6-0 zone; porch right exposed; C-C for members and forces & MWFRS for reactions shown; Lumber DOL=1.60 plate grip DOL=1.60
- Building Designer / Project engineer responsible for verifying applied roof live load shown covers rain loading requirements specific to the use of this truss component.
- Provide adequate drainage to prevent water ponding.
- This truss has been designed for a 10.0 psf bottom chord live load nonconcurrent with any other live loads.
- * This truss has been designed for a live load of 20.0psf on the bottom chord in all areas where a rectangle 3-06-00 tall by 2-00-00 wide will fit between the bottom chord and any other members.
- Bearing at joint(s) 2 considers parallel to grain value using ANSI/TPI 1 angle to grain formula. Building designer should verify capacity of bearing surface.
- Provide mechanical connection (by others) of truss to bearing plate capable of withstanding 370 lb uplift at joint 2, 598 lb uplift at joint 12 and 399 lb uplift at joint 15.
- Graphical purlin representation does not depict the size or the orientation of the purlin along the top and/or bottom chord.

LOAD CASE(S) Standard

This item has been digitally signed and sealed by O'Regan, Philip, PE on the date indicated here. Printed copies of this document are not considered signed and sealed and the signature must be verified on any electronic copies.

Philip J. O'Regan PE No.58126
MITek Inc. DBA MITek USA FL Cert 6634
16023 Swingley Ridge Rd. Chesterfield, MO 63017
Date:

February 23, 2026

WARNING - Verify design parameters and READ NOTES ON THIS AND INCLUDED MITEK REFERENCE PAGE MII-7473 rev. 1/2/2023 BEFORE USE.

Design valid for use only with MITek® connectors. This design is based only upon parameters shown, and is for an individual building component, not a truss system. Before use, the building designer must verify the applicability of design parameters and properly incorporate this design into the overall building design. Bracing indicated is to prevent buckling of individual truss web and/or chord members only. Additional temporary and permanent bracing is always required for stability and to prevent collapse with possible personal injury and property damage. For general guidance regarding the fabrication, storage, delivery, erection and bracing of trusses and truss systems, see ANSI/TPI Quality Criteria and DSB-22 available from Truss Plate Institute (www.tpinst.org) and BCSI Building Component Safety Information available from the Structural Building Component Association (www.sbcsccomponents.com)

MiTek®

16023 Swingley Ridge Rd.
Chesterfield, MO 63017
314.434.1200 / MiTek-US.com

Job 5263975	Truss T08	Truss Type Piggyback Base	Qty 3	Ply 1	Job Reference (optional)	T40209563
----------------	--------------	------------------------------	----------	----------	--------------------------	-----------

Builders FirstSource (Lake City,FL), Lake City, FL - 32055,

Run: 8.83 S Jan 22 2026 Print: 8.830 S Jan 22 2026 MITek Industries, Inc. Fri Feb 20 08:24:11
ID:Pe5L7W7(7)OoTX6SP4fU7Izjtlu-RfC?Psb70Hq3NSgPqnl8w3ulTXbGKWrCDoI7J4zJC7f

Page: 1

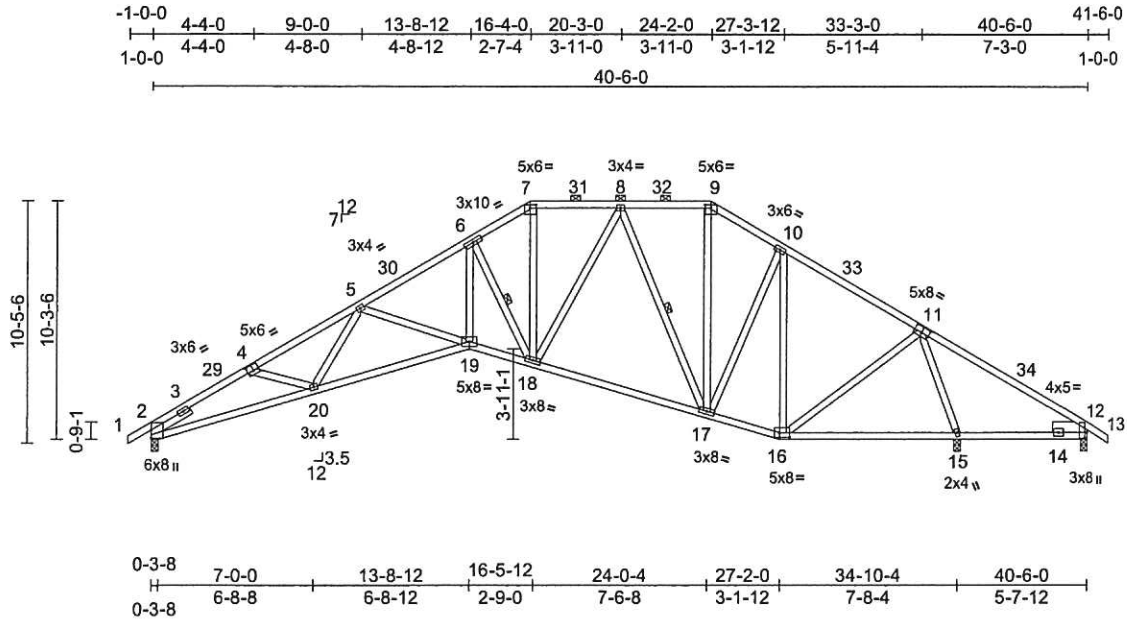

Scale = 1:99.7
Plate Offsets (X, Y): [4:0-3-0,0-3-0], [7:0-3-0,0-1-12], [9:0-3-0,0-1-12], [11:0-4-0,0-3-0], [12:0-2-13,0-1-3], [16:0-5-4,0-2-8]

Loading	(psf)	Spacing	2-0-0	CSI	DEFL	in	(loc)	l/defl	L/d	PLATES	GRIP	
TCLL (roof)	20.0	Plate Grip DOL	1.25	TC	0.77	Vert(LL)	-0.26	19-20	>999	240	MT20	244/190
TCDL	10.0	Lumber DOL	1.25	BC	0.89	Vert(CT)	-0.56	19-20	>752	180		
BCLL	0.0*	Rep Stress Incr	YES	WB	1.00	Horz(CT)	0.31	15	n/a	n/a		
BCDL	10.0	Code	FBC2023/TPI2014	Matrix-MS							Weight: 262 lb	FT = 20%

LUMBER
TOP CHORD 2x4 SP No.2 *Except* 1-4:2x4 SP 2700F
2.2E or 2x4 SP 2850F 2.0E or 2x4 SP M 31
BOT CHORD 2x4 SP No.2 *Except* 2-19:2x4 SP No.1
WEBS 2x4 SP No.3
SLIDER Left 2x4 SP No.3 - 2-0-0, Right 2x6 SP No.2
- 1-6-0

BRACING
TOP CHORD Structural wood sheathing directly applied or
2-2-0 oc purlins, except
2-0-0 oc purlins (4-6-15 max.): 7-9.
BOT CHORD Rigid ceiling directly applied or 3-1-0 oc
bracing.
WEBS 1 Row at midpt 6-18, 8-17

REACTIONS (size) 2=0-3-8, 12=0-3-8, 15=0-3-8
Max Horiz 2=-250 (LC 10)
Max Uplift 2=-352 (LC 12), 12=-449 (LC 25),
15=-419 (LC 12)
Max Grav 2=1371 (LC 1), 12=95 (LC 12),
15=2236 (LC 1)

FORCES (lb) - Maximum Compression/Maximum
Tension
TOP CHORD 1-2=0/30, 2-5=-3236/922, 5-6=-2772/723,
6-7=-1852/537, 7-8=-1576/486,
8-9=-935/395, 9-10=-1137/432,
10-12=-982/1027, 12-13=0/30
BOT CHORD 2-20=-892/2764, 19-20=-795/2866,
18-19=-530/2417, 17-18=-222/1347,
16-17=-95/786, 15-16=-299/94,
12-15=-825/386
WEBS 6-19=-446/1710, 6-18=-1653/527,
7-18=-184/737, 9-17=-131/370,
10-17=-177/541, 10-16=-784/157,
11-16=-179/1059, 11-15=-2069/452,
4-20=-36/162, 5-20=-3/194, 5-19=-497/268,
8-17=-901/272, 8-18=-175/689

- Unbalanced roof live loads have been considered for this design.
 - Wind: ASCE 7-22; Vult=130mph (3-second gust)
Vasd=101mph; TCDL=4.2psf; BCDL=3.0psf; h=18ft; Cat. II; Exp B; Enclosed; MWFRS (envelope) exterior (2) zone and C-C Zone3 -1-0-0 to 3-0-10, Zone1 3-0-10 to 16-4-0, Zone2 16-4-0 to 22-0-12, Zone1 22-0-12 to 24-2-0, Zone2 24-2-0 to 29-10-12, Zone1 29-10-12 to 41-6-0 zone; porch right exposed; C-C for members and forces & MWFRS for reactions shown; Lumber DOL=1.60 plate grip DOL=1.60
 - Building Designer / Project engineer responsible for verifying applied roof live load shown covers rain loading requirements specific to the use of this truss component.
 - Provide adequate drainage to prevent water ponding.
 - This truss has been designed for a 10.0 psf bottom chord live load nonconcurrent with any other live loads.
 - * This truss has been designed for a live load of 20.0psf on the bottom chord in all areas where a rectangle 3-06-00 tall by 2-00-00 wide will fit between the bottom chord and any other members.
 - Bearing at joint(s) 2 considers parallel to grain value using ANSI/TPI 1 angle to grain formula. Building designer should verify capacity of bearing surface.
 - Provide mechanical connection (by others) of truss to bearing plate capable of withstanding 352 lb uplift at joint 2, 449 lb uplift at joint 12 and 419 lb uplift at joint 15.
 - Graphical purlin representation does not depict the size or the orientation of the purlin along the top and/or bottom chord.
- LOAD CASE(S)** Standard

This item has been digitally signed and sealed by ORegan, Philip, PE on the date indicated here. Printed copies of this document are not considered signed and sealed and the signature must be verified on any electronic copies.

Philip J. O'Regan PE No.59126
MITek Inc. DBA MITek USA FL Cert 6634
16023 Swingley Ridge Rd. Chesterfield, MO 63017
Date:

February 23, 2026

Job 5263975	Truss T09	Truss Type Piggyback Base	Qty 1	Ply 1	Job Reference (optional)	T40209564
----------------	--------------	------------------------------	----------	----------	--------------------------	-----------

Builders FirstSource (Lake City,FL), Lake City, FL - 32055,

Run: 8.83 S Jan 22 2026 Print: 8.830 S Jan 22 2026 MiTek Industries, Inc. Fri Feb 20 08:24:11
ID:?Q2LKly7[pvj9J7ODCI8IK2zjHc-RfC?PsB70Hq3NSgPqnL8w3uITXbGKWrCDoi7J4zJC7f

Page: 1

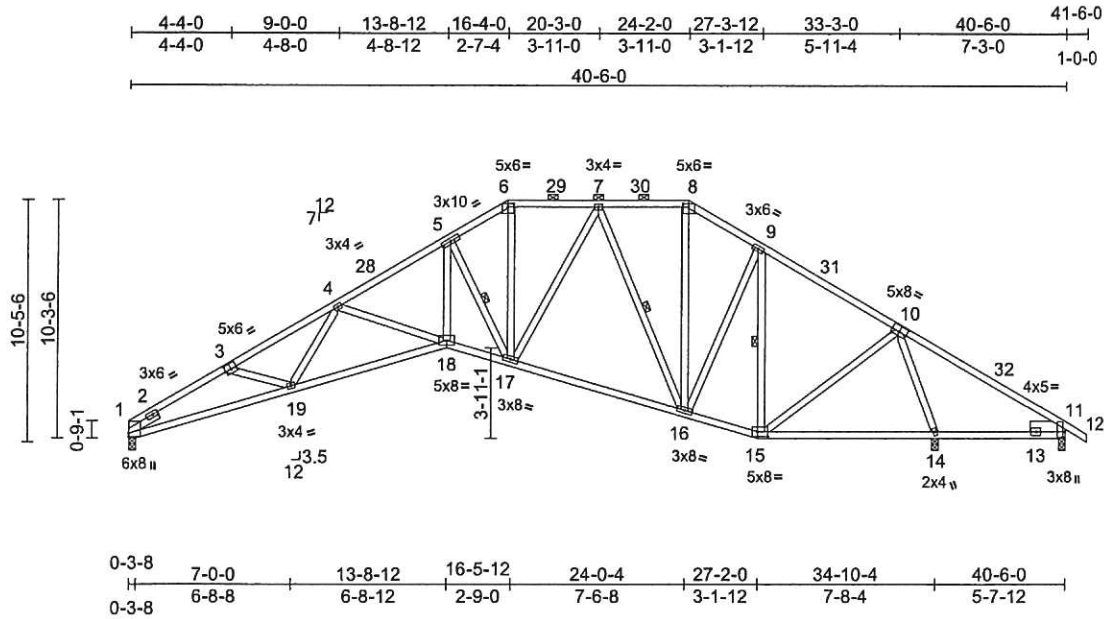

Scale = 1:99.7

Plate Offsets (X, Y): [3:0-3-0,0-3-0], [6:0-3-0,0-1-12], [8:0-3-0,0-1-12], [10:0-4-0,0-3-0], [11:0-2-13,0-1-3], [15:0-5-4,0-2-8]

Loading	(psf)	Spacing	2-0-0	CSI	DEFL	in (loc)	l/defl	L/d	PLATES	GRIP
TCLL (roof)	20.0	Plate Grip DOL	1.25	TC	0.78	Vert(LL)	-0.27	18-19	>999	240
TCDL	10.0	Lumber DOL	1.25	BC	0.90	Vert(CT)	-0.58	18-19	>722	180
BCLL	0.0*	Rep Stress Incr	YES	WB	1.00	Horz(CT)	0.31	14	n/a	n/a
BCDL	10.0	Code	FBC2023/TPI2014	Matrix-MS						
									Weight: 259 lb	FT = 20%

LUMBER
TOP CHORD 2x4 SP No.2 *Except* 1-3:2x4 SP 2700F
2.2E or 2x4 SP 2850F 2.0E or 2x4 SP M 31
BOT CHORD 2x4 SP No.2 *Except* 1-18:2x4 SP No.1
WEBS 2x4 SP No.3
SLIDER Left 2x4 SP No.3 - 1-6-0, Right 2x6 SP No.2
-- 1-6-0

BRACING
TOP CHORD Structural wood sheathing directly applied or
2-2-0 oc purlins, except
2-0-0 oc purlins (4-7-1 max.): 6-8.
BOT CHORD Rigid ceiling directly applied or 2-6-7 oc
bracing.
WEBS 1 Row at midpt 5-17, 9-15, 7-16

REACTIONS (size) 1=0-3-8, 11=0-3-8, 14=0-3-8
Max Horiz 1=-246 (LC 8)
Max Uplift 1=-326 (LC 12), 11=-470 (LC 25),
14=-426 (LC 12)
Max Grav 1=1307 (LC 1), 11=102 (LC 12),
14=2264 (LC 1)

FORCES (lb) - Maximum Compression/Maximum
Tension
TOP CHORD 1-4=-3248/921, 4-5=-2764/721,
5-6=-1845/535, 6-7=-1570/484,
7-8=-926/394, 8-9=-1127/431,
9-11=-969/1063, 11-12=0/30
BOT CHORD 1-19=-894/2770, 18-19=-794/2864,
17-18=-528/2411, 16-17=-221/1339,
15-16=-93/774, 14-15=-323/98,
11-14=-857/381
WEBS 5-18=-446/1710, 5-17=-1653/527,
6-17=-182/733, 8-16=-130/364,
9-16=-178/548, 9-15=-792/159,
10-15=-184/1076, 10-14=-2095/460,
3-19=-36/155, 4-19=-2/190, 4-18=-498/268,
7-16=-904/273, 7-17=-176/692

NOTES

- Unbalanced roof live loads have been considered for this design.
- Wind: ASCE 7-22; Vult=130mph (3-second gust) Vasd=101mph; TCDL=4.2psf; BCDL=3.0psf; h=18ft; Cat. II; Exp B; Enclosed; MWFRS (envelope) exterior (2) zone and C-C Zone3 0-0-0 to 4-3-12, Zone1 4-3-12 to 16-4-0, Zone2 16-4-0 to 22-0-12, Zone1 22-0-12 to 24-2-0, Zone2 24-2-0 to 29-10-12, Zone1 29-10-12 to 41-6-0 zone; porch right exposed;C-C for members and forces & MWFRS for reactions shown; Lumber DOL=1.60 plate grip DOL=1.60
- Building Designer / Project engineer responsible for verifying applied roof live load shown covers rain loading requirements specific to the use of this truss component.
- Provide adequate drainage to prevent water ponding.
- This truss has been designed for a 10.0 psf bottom chord live load nonconcurrent with any other live loads.
- * This truss has been designed for a live load of 20.0psf on the bottom chord in all areas where a rectangle 3-06-00 tall by 2-00-00 wide will fit between the bottom chord and any other members.
- Bearing at joint(s) 1 considers parallel to grain value using ANSI/TPI 1 angle to grain formula. Building designer should verify capacity of bearing surface.
- Provide mechanical connection (by others) of truss to bearing plate capable of withstanding 326 lb uplift at joint 1, 470 lb uplift at joint 11 and 426 lb uplift at joint 14.
- Graphical purlin representation does not depict the size or the orientation of the purlin along the top and/or bottom chord.

LOAD CASE(S) Standard

This item has been digitally signed and sealed by O'Regan, Philip, PE on the date indicated here. Printed copies of this document are not considered signed and sealed and the signature must be verified on any electronic copies.

Philip J. O'Regan PE No.58126
MiTek Inc. DBA MiTek USA FL Cert 6634
16023 Swingley Ridge Rd. Chesterfield, MO 63017
Date:

February 23,2026

WARNING - Verify design parameters and READ NOTES ON THIS AND INCLUDED MITEK REFERENCE PAGE MII-7473 rev. 1/2/2023 BEFORE USE.

Design valid for use only with MiTek® connectors. This design is based only upon parameters shown, and is for an individual building component, not a truss system. Before use, the building designer must verify the applicability of design parameters and properly incorporate this design into the overall building design. Bracing indicated is to prevent buckling of individual truss web and/or chord members only. Additional temporary and permanent bracing is always required for stability and to prevent collapse with possible personal injury and property damage. For general guidance regarding the fabrication, storage, delivery, erection and bracing of trusses and truss systems, see ANSI/TPI1 Quality Criteria and DSB-22 available from Truss Plate Institute (www.tpiinst.org) and BCSI Building Component Safety Information available from the Structural Building Component Association (www.sbcscomponents.com)

MiTek®

16023 Swingley Ridge Rd.
Chesterfield, MO 63017
314.434.1200 / MiTek-US.com

Job 5263975	Truss T10	Truss Type Piggyback Base	Qty 5	Ply 1	Job Reference (optional)	T40209565
----------------	--------------	------------------------------	----------	----------	--------------------------	-----------

Builders FirstSource (Lake City,FL), Lake City, FL - 32055,

Run: 8.83 S Jan 22 2026 Print: 8.830 S Jan 22 2026 MITek Industries, Inc. Fri Feb 20 08:24:12
ID:0V92cpxyoolWTaaHBaM4OzjtGY-RIC?PsB70Hq3NSgPqL8w3uITXbGKWrCDoi7J4zJC7f

Page: 1

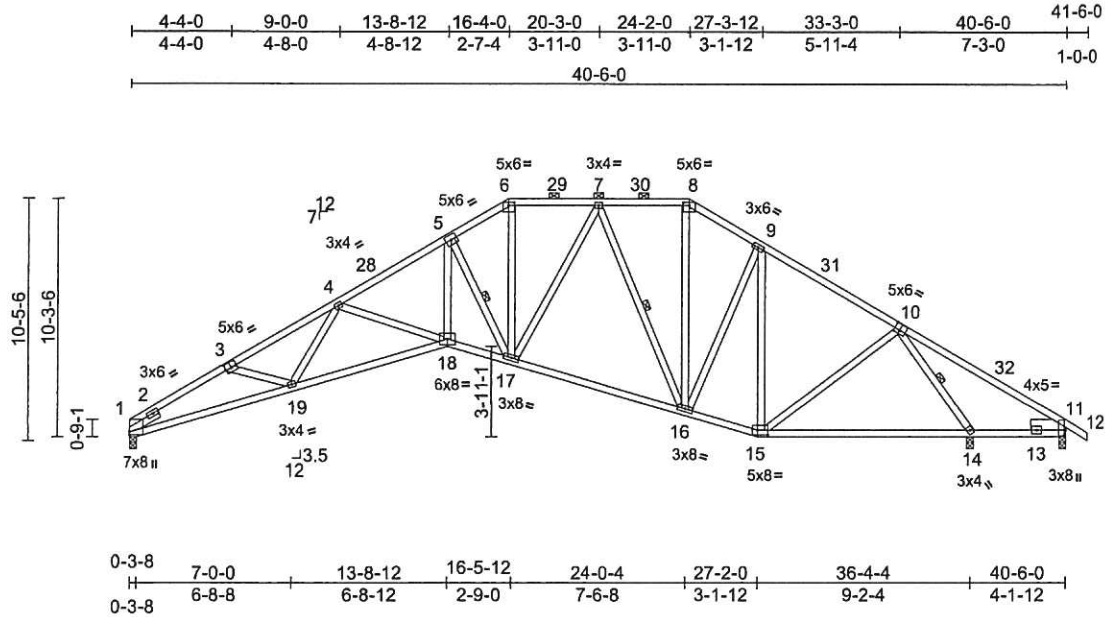

Scale = 1:99.7

Plate Offsets (X, Y): [3:0-3-0,0-3-0], [6:0-3-0,0-1-12], [8:0-3-0,0-1-12], [10:0-2-12,0-3-4], [11:0-2-13,0-0-11], [15:0-5-4,0-2-8]

Loading	(psf)	Spacing	2-0-0	CSI	DEFL	in	(loc)	l/defl	L/d	PLATES	GRIP	
TCLL (roof)	20.0	Plate Grip DOL	1.25	TC	0.80	Vert(LL)	-0.29	18-19	>999	240	MT20	244/190
TCDL	10.0	Lumber DOL	1.25	BC	0.92	Vert(CT)	-0.60	18-19	>724	180		
BCLL	0.0*	Rep Stress Incr	YES	WB	0.81	Horz(CT)	0.33	14	n/a	n/a		
BCDL	10.0	Code	FBC2023/TPI2014	Matrix-MS							Weight: 260 lb	FT = 20%

LUMBER
TOP CHORD 2x4 SP No.2 *Except* 1-3:2x4 SP 2700F 2.2E or 2x4 SP 2850F 2.0E or 2x4 SP M 31
BOT CHORD 2x4 SP No.2 *Except* 1-18:2x4 SP 2700F 2.2E or 2x4 SP 2850F 2.0E or 2x4 SP M 31
WEBS 2x4 SP No.3
SLIDER Left 2x4 SP No.3 - 1-6-0, Right 2x6 SP No.2 - 1-6-0

BRACING
TOP CHORD Structural wood sheathing directly applied or 2-2-0 oc purlins, except 2-0-0 oc purlins (4-4-0 max.): 6-8.
BOT CHORD Rigid ceiling directly applied or 2-2-0 oc bracing.
WEBS 1 Row at midpt 5-17, 10-14, 7-16

REACTIONS (size) 1=0-3-8, 11=0-3-8, 14=0-3-8
 Max Horiz 1=-246 (LC 10)
 Max Uplift 1=-345 (LC 12), 11=-594 (LC 25), 14=-398 (LC 12)
 Max Grav 1=1385 (LC 1), 11=92 (LC 12), 14=2344 (LC 1)

FORCES (lb) - Maximum Compression/Maximum Tension
TOP CHORD 1-4=-3474/976, 4-5=-3039/789, 5-6=-2061/587, 6-7=-1759/530, 7-8=-1134/426, 8-9=-1368/468, 9-11=-1271/1165, 11-12=0/30
BOT CHORD 1-19=-942/2967, 18-19=-850/3090, 17-18=-589/2657, 16-17=-245/1547, 15-16=-123/1050, 14-15=-191/485, 11-14=-945/444
WEBS 5-18=-479/1839, 5-17=-1762/554, 6-17=-208/840, 8-16=-160/488, 9-16=-170/426, 9-15=-637/127, 10-15=-132/760, 10-14=-2387/482, 3-19=-35/164, 4-19=-28/169, 4-18=-481/263, 7-16=-885/271, 7-17=-171/673

- Unbalanced roof live loads have been considered for this design.
- Wind: ASCE 7-22; Vult=130mph (3-second gust) Vasd=101mph; TCDL=4.2psf; BCDL=3.0psf; h=18ft; Cat. II; Exp B; Enclosed; MWFRS (envelope) exterior (2) zone and C-C Zone3 0-0-0 to 4-3-12, Zone1 4-3-12 to 16-4-0, Zone2 16-4-0 to 22-0-12, Zone1 22-0-12 to 24-2-0, Zone2 24-2-0 to 29-10-12, Zone1 29-10-12 to 41-6-0 zone; porch right exposed; C-C for members and forces & MWFRS for reactions shown; Lumber DOL=1.60 plate grip DOL=1.60
- Building Designer / Project engineer responsible for verifying applied roof live load shown covers rain loading requirements specific to the use of this truss component.
- Provide adequate drainage to prevent water ponding.
- This truss has been designed for a 10.0 psf bottom chord live load nonconcurrent with any other live loads.
- * This truss has been designed for a live load of 20.0psf on the bottom chord in all areas where a rectangle 3-06-00 tall by 2-00-00 wide will fit between the bottom chord and any other members.
- Bearing at joint(s) 1 considers parallel to grain value using ANSI/TPI 1 angle to grain formula. Building designer should verify capacity of bearing surface.
- Provide mechanical connection (by others) of truss to bearing plate capable of withstanding 345 lb uplift at joint 1, 594 lb uplift at joint 11 and 398 lb uplift at joint 14.
- Graphical purlin representation does not depict the size or the orientation of the purlin along the top and/or bottom chord.

LOAD CASE(S) Standard

This item has been digitally signed and sealed by O'Regan, Philip, PE on the date indicated here. Printed copies of this document are not considered signed and sealed and the signature must be verified on any electronic copies.

Philip J. O'Regan PE No.58126
 MITek Inc. DBA MITek USA FL Cert 6634
 16023 Swingley Ridge Rd. Chesterfield, MO 63017
 Date:

February 23, 2026

WARNING - Verify design parameters and READ NOTES ON THIS AND INCLUDED MITEK REFERENCE PAGE MII-7473 rev. 1/2/2023 BEFORE USE.

Design valid for use only with MITek® connectors. This design is based only upon parameters shown, and is for an individual building component, not a truss system. Before use, the building designer must verify the applicability of design parameters and properly incorporate this design into the overall building design. Bracing indicated is to prevent buckling of individual truss web and/or chord members only. Additional temporary and permanent bracing is always required for stability and to prevent collapse with possible personal injury and property damage. For general guidance regarding the fabrication, storage, delivery, erection and bracing of trusses and truss systems, see ANSI/TPI1 Quality Criteria and DSB-22 available from Truss Plate Institute (www.tpinst.org) and BCSI Building Component Safety Information available from the Structural Building Component Association (www.sbcsccomponents.com)

MiTek®
 16023 Swingley Ridge Rd.
 Chesterfield, MO 63017
 314.434.1200 / MITek-US.com

Job 5263975	Truss T10G	Truss Type Piggyback Base	Qty 1	Ply 1	Job Reference (optional)	T40209566
----------------	---------------	------------------------------	----------	----------	--------------------------	-----------

Builders FirstSource (Lake City,FL), Lake City, FL - 32055,

Run: 8.83 S Jan 22 2026 Print: 8.830 S Jan 22 2026 MITek Industries, Inc. Fri Feb 20 08:24:12
ID:p4VboN2nAe6cn4DZd_gi19zjstu-RfC?PsB70Hq3NsgPqL8w3ulTXbGKwRCDoi7J4zJC?F

Page: 1

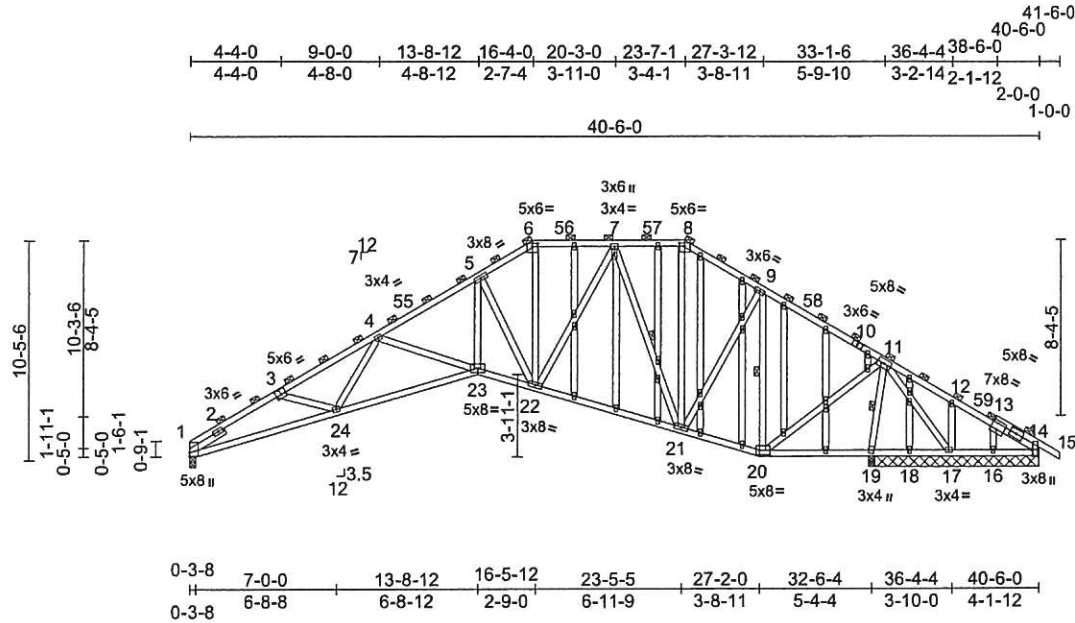

Scale = 1:109.8

Plate Offsets (X, Y): [3:0-3-0,0-3-0], [6:0-3-0,0-1-12], [7:0-2-1,0-1-8], [8:0-3-0,0-1-12], [13:Edge,0-5-0], [14:0-3-8,Edge], [20:0-6-0,0-2-8]

Loading	(psf)	Spacing	2-0-0	CSI	DEFL	in (loc)	I/defl	L/d	PLATES	GRIP
TCLL (roof)	20.0	Plate Grip DOL	1.25	TC	0.91	Vert(LL)	-0.22	23-24	>999	240
TCDL	10.0	Lumber DOL	1.25	BC	0.95	Vert(CT)	-0.48	23-24	>807	180
BCLL	0.0*	Rep Stress Incr	YES	WB	0.95	Horz(CT)	0.25	19	n/a	n/a
BCDL	10.0	Code	FBC2023/TPI2014	Matrix-MS						
									Weight: 352 lb	FT = 20%

LUMBER

TOP CHORD 2x4 SP No.2 *Except* 1-3:2x4 SP No.1

BOT CHORD 2x4 SP No.2

WEBS 2x4 SP No.3

OTHERS 2x4 SP No.3

SLIDER Left 2x4 SP No.3 - 2-0-0

BRACING

TOP CHORD 2-0-0 oc purlins (2-2-0 max.).

BOT CHORD Rigid ceiling directly applied or 2-2-0 oc bracing.

WEBS 1 Row at midpt 9-20, 7-21, 11-19

REACTIONS (size)

1=0-3-8, 14=8-1-8, 16=8-1-8, 17=8-1-8, 18=8-1-8, 19=0-3-8

Max Horiz 1=-246 (LC 10)

Max Uplift 1=-278 (LC 12), 14=-368 (LC 25), 16=-34 (LC 13), 17=-526 (LC 25), 18=-30 (LC 1), 19=-619 (LC 12)

Max Grav 1=1120 (LC 1), 14=116 (LC 12), 16=169 (LC 1), 17=181 (LC 9), 18=8 (LC 12), 19=2700 (LC 1)

FORCES (lb) - Maximum Compression/Maximum Tension

TOP CHORD 1-4=-2709/787, 4-5=-2108/552, 5-6=-1329/403, 6-7=-1119/369, 7-8=-488/296, 8-9=-636/313, 9-11=-367/239, 11-12=-192/878, 12-14=-234/864, 14-15=0/30

BOT CHORD 1-24=-777/2332, 23-24=-651/2311, 22-23=-375/1824, 21-22=-152/842, 20-21=-36/247, 19-20=-1480/461, 18-19=-1111/368, 17-18=-1111/368, 16-17=-701/231, 14-16=-701/231

WEBS

5-23=-364/1404, 5-22=-1393/456, 6-22=-116/473, 8-21=-70/156, 9-21=-197/773, 9-20=-1165/262, 3-24=-32/131, 4-24=-24/247, 4-23=-529/278, 11-20=-451/2007, 7-21=-907/277, 7-22=-193/730, 11-17=-233/744, 11-19=-2576/647, 12-17=-184/131

- NOTES**
- Unbalanced roof live loads have been considered for this design.
 - Wind: ASCE 7-22; Vult=130mph (3-second gust) Vasd=101mph; TCDL=4.2psf; BCDL=3.0psf; h=18ft; Cat. II; Exp B; Enclosed; MWFRS (envelope) exterior (2) zone and C-C Zone3 0-0-0 to 4-3-12, Zone1 4-3-12 to 16-4-0, Zone2 16-4-0 to 22-0-12, Zone1 22-0-12 to 23-7-1, Zone2 23-7-1 to 29-3-13, Zone1 29-3-13 to 41-6-0 zone; porch right exposed; C-C for members and forces & MWFRS for reactions shown; Lumber DOL=1.60 plate grip DOL=1.60
 - Truss designed for wind loads in the plane of the truss only. For studs exposed to wind (normal to the face), see Standard Industry Gable End Details as applicable, or consult qualified building designer as per ANSI/TPI 1.
 - Building Designer / Project engineer responsible for verifying applied roof live load shown covers rain loading requirements specific to the use of this truss component.
 - Provide adequate drainage to prevent water ponding.
 - All plates are 2x4 (||) MT20 unless otherwise indicated.
 - Gable studs spaced at 2-0-0 oc.
 - This truss has been designed for a 10.0 psf bottom chord live load nonconcurrent with any other live loads.
 - * This truss has been designed for a live load of 20.0psf on the bottom chord in all areas where a rectangle 3-06-00 tall by 2-00-00 wide will fit between the bottom chord and any other members.
 - Bearing at joint(s) 1 considers parallel to grain value using ANSI/TPI 1 angle to grain formula. Building designer should verify capacity of bearing surface.

- Provide mechanical connection (by others) of truss to bearing plate capable of withstanding 278 lb uplift at joint 1, 368 lb uplift at joint 14, 526 lb uplift at joint 17, 30 lb uplift at joint 18, 34 lb uplift at joint 16, 619 lb uplift at joint 19 and 368 lb uplift at joint 14.
- Graphical purlin representation does not depict the size or the orientation of the purlin along the top and/or bottom chord.

LOAD CASE(S) Standard

This item has been digitally signed and sealed by ORegan, Philip, PE on the date indicated here. Printed copies of this document are not considered signed and sealed and the signature must be verified on any electronic copies.

Philip J. O'Regan PE No.59126
MITek Inc. DBA MITek USA FL Cert 6634
16023 Swingley Ridge Rd. Chesterfield, MD 63017
Date:

February 23,2026

WARNING - Verify design parameters and READ NOTES ON THIS AND INCLUDED MITEK REFERENCE PAGE MII-7473 rev. 1/2/2023 BEFORE USE.

Design valid for use only with MITek® connectors. This design is based only upon parameters shown, and is for an individual building component, not a truss system. Before use, the building designer must verify the applicability of design parameters and properly incorporate this design into the overall building design. Bracing indicated is to prevent buckling of individual truss web and/or chord members only. Additional temporary and permanent bracing is always required for stability and to prevent collapse with possible personal injury and property damage. For general guidance regarding the fabrication, storage, delivery, erection and bracing of trusses and truss systems, see ANSI/TPI1 Quality Criteria and DSB-22 available from Truss Plate Institute (www.tpinst.org) and BCSI Building Component Safety Information available from the Structural Building Component Association (www.sbcsccomponents.com)

MiTek®
16023 Swingley Ridge Rd.
Chesterfield, MO 63017
314.434.1200 / MITek-US.com

Job 5263975	Truss T11	Truss Type Monopitch	Qty 8	Ply 1	Job Reference (optional)	T40209567
----------------	--------------	-------------------------	----------	----------	--------------------------	-----------

Builders FirstSource (Lake City,FL), Lake City, FL - 32055,

Run: 8.83 S Jan 22 2026 Print: 8.830 S Jan 22 2026 MiTek Industries, Inc. Fri Feb 20 08:24:13
ID:dQQonM8WPycDb?SnlLH_Bczju_m-RfC?Psb70Hq3NSgPqnL8w3uITxbGKWrCDoI7J4zJC?F

Page: 1

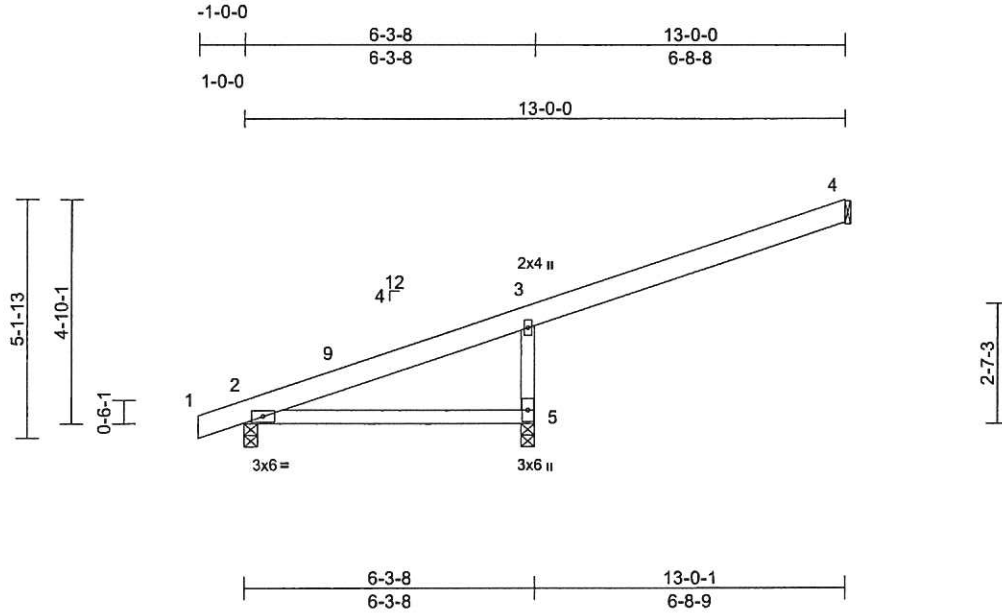

Scale = 1:49.9

Loading	(psf)	Spacing	2-0-0	CSI	DEFL	in	(loc)	l/defl	L/d	PLATES	GRIP
TCLL (roof)	20.0	Plate Grip DOL	1.25	TC	0.29	Vert(LL)	0.05	5-8	>999	240	244/190
TCDL	10.0	Lumber DOL	1.25	BC	0.26	Vert(CT)	-0.07	5-8	>999	180	
BCLL	0.0*	Rep Stress Incr	YES	WB	0.00	Horz(CT)	0.00	4	n/a	n/a	
BCDL	10.0	Code	FBC2023/TPI2014	Matrix-MP							
										Weight: 47 lb	FT = 20%

LUMBER

TOP CHORD 2x6 SP No.2
BOT CHORD 2x4 SP No.2
WEBS 2x4 SP No.3

- 6) Refer to girder(s) for truss to truss connections.
7) Provide mechanical connection (by others) of truss to bearing plate capable of withstanding 92 lb uplift at joint 4, 319 lb uplift at joint 5 and 101 lb uplift at joint 2.

BRACING

TOP CHORD Structural wood sheathing directly applied or 6-0-0 oc purlins, except end verticals.
BOT CHORD Rigid ceiling directly applied or 10-0-0 oc bracing.

LOAD CASE(S) Standard

REACTIONS (size) 2=0-3-8, 4= Mechanical, 5=0-3-8
Max Horiz 2=184 (LC 8)
Max Uplift 2=-101 (LC 8), 4=-92 (LC 12), 5=319 (LC 8)
Max Grav 2=258 (LC 1), 4=156 (LC 1), 5=545 (LC 1)

FORCES (lb) - Maximum Compression/Maximum Tension

TOP CHORD 1-2=0/19, 2-3=-216/107, 3-4=-86/36, 3-5=-495/452
BOT CHORD 2-5=-78/55

NOTES

- Unbalanced roof live loads have been considered for this design.
- Wind: ASCE 7-22; Vult=130mph (3-second gust) Vasd=101mph; TC DL=4.2psf; BCDL=3.0psf; h=18ft; Cat. II; Exp B; Enclosed; MWFRS (envelope) exterior (2) zone and C-C Zone3 -1-0-0 to 2-0-0, Zone1 2-0-0 to 12-11-4 zone; porch left and right exposed; C-C for members and forces & MWFRS for reactions shown; Lumber DOL=1.60 plate grip DOL=1.60
- Building Designer / Project engineer responsible for verifying applied roof live load shown covers rain loading requirements specific to the use of this truss component.
- This truss has been designed for a 10.0 psf bottom chord live load nonconcurrent with any other live loads.
- * This truss has been designed for a live load of 20.0psf on the bottom chord in all areas where a rectangle 3-06-00 tall by 2-00-00 wide will fit between the bottom chord and any other members.

This item has been digitally signed and sealed by O'Regan, Philip, PE on the date indicated here. Printed copies of this document are not considered signed and sealed and the signature must be verified on any electronic copies.

Philip J. O'Regan PE No.58126
MiTek Inc. DBA MiTek USA FL Cert 6634
16023 Swingley Ridge Rd. Chesterfield, MO 63017
Date:

February 23,2026

WARNING - Verify design parameters and READ NOTES ON THIS AND INCLUDED MITEK REFERENCE PAGE MII-7473 rev. 1/2/2023 BEFORE USE.

Design valid for use only with MiTek® connectors. This design is based only upon parameters shown, and is for an individual building component, not a truss system. Before use, the building designer must verify the applicability of design parameters and properly incorporate this design into the overall building design. Bracing indicated is to prevent buckling of individual truss web and/or chord members only. Additional temporary and permanent bracing is always required for stability and to prevent collapse with possible personal injury and property damage. For general guidance regarding the fabrication, storage, delivery, erection and bracing of trusses and truss systems, see **ANSI/TPI1 Quality Criteria** and **DSB-22** available from Truss Plate Institute (www.tpinst.org) and **BCSI Building Component Safety Information** available from the Structural Building Component Association (www.sbcsccomponents.com)

MiTek®

16023 Swingley Ridge Rd.
Chesterfield, MO 63017
314.434.1200 / MiTek-US.com

Job 5263975	Truss T11G	Truss Type Monopitch Supported Gable	Qty 2	Ply 1	Job Reference (optional) T40209568
----------------	---------------	---	----------	----------	---------------------------------------

Builders FirstSource (Lake City,FL), Lake City, FL - 32055.

Run: 8.83 S Jan 22 2026 Print: 8.830 S Jan 22 2026 MiTek Industries, Inc. Fri Feb 20 08:24:13
ID:A7PB6Lwa_3IF11bPpTpvYzjsl-RfC?PsB70Hq3NSgPqnL8w3uitXbGKwRCDoi7J4zJC?I

Page: 1

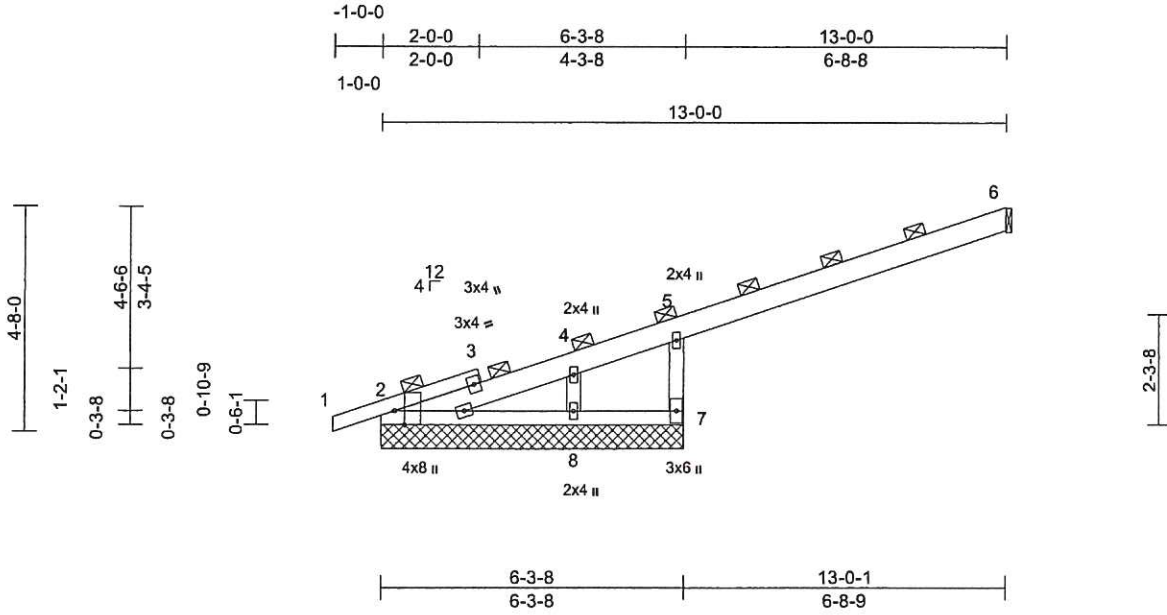

Scale = 1:48

Plate Offsets (X, Y): [2:0-3-8,Edge]

Loading	(psf)	Spacing	2-0-0	CSI	DEFL	in	(loc)	l/defl	L/d	PLATES	GRIP	
TCLL (roof)	20.0	Plate Grip DOL	1.25	TC	0.32	Vert(LL)	0.01	8-11	>999	240	MT20	244/190
TCDL	10.0	Lumber DOL	1.25	BC	0.14	Vert(CT)	-0.01	8-11	>999	180		
BCLL	0.0*	Rep Stress Incr	YES	WB	0.01	Horz(CT)	0.00	6	n/a	n/a		
BCDL	10.0	Code	FBC2023/TPI2014	Matrix-MP							Weight: 49 lb	FT = 20%

LUMBER

TOP CHORD 2x4 SP No.3 *Except* 2-6:2x6 SP No.2
 BOT CHORD 2x4 SP No.2
 WEBS 2x4 SP No.3
 OTHERS 2x4 SP No.3

BRACING

TOP CHORD 2-0-0 oc purlins (6-0-0 max.), except end verticals.
 BOT CHORD Rigid ceiling directly applied or 10-0-0 oc bracing.

REACTIONS

(size) 2=6-3-8, 6= Mechanical, 7=6-3-8, 8=6-3-8
 Max Horiz 2=168 (LC 8)
 Max Uplift 2=-53 (LC 8), 6=-95 (LC 12), 7=-233 (LC 8), 8=-21 (LC 12)
 Max Grav 2=207 (LC 1), 6=165 (LC 1), 7=412 (LC 1), 8=203 (LC 3)

FORCES

(lb) - Maximum Compression/Maximum Tension
 TOP CHORD 1-2=0/19, 2-4=-340/96, 4-5=-321/91, 5-6=-102/39, 5-7=-408/676
 BOT CHORD 2-8=-128/74, 7-8=0/0
 WEBS 4-8=-74/50

NOTES

- 1) Unbalanced roof live loads have been considered for this design.
- 2) Wind: ASCE 7-22; Vult=130mph (3-second gust) Vasd=101mph; TC DL=4.2psf; BCDL=3.0psf; h=18ft; Cat. II; Exp B; Enclosed; MWFRS (envelope) exterior (2) zone and C-C Zone3 zone; C-C for members and forces & MWFRS for reactions shown; Lumber DOL=1.60 plate grip DOL=1.60
- 3) Truss designed for wind loads in the plane of the truss only. For studs exposed to wind (normal to the face), see Standard Industry Gable End Details as applicable, or consult qualified building designer as per ANSI/TPI 1.

- 4) Building Designer / Project engineer responsible for verifying applied roof live load shown covers rain loading requirements specific to the use of this truss component.
- 5) Gable studs spaced at 2-0-0 oc.
- 6) This truss has been designed for a 10.0 psf bottom chord live load nonconcurrent with any other live loads.
- 7) * This truss has been designed for a live load of 20.0psf on the bottom chord in all areas where a rectangle 3-06-00 tall by 2-00-00 wide will fit between the bottom chord and any other members.
- 8) Refer to girder(s) for truss to truss connections.
- 9) Provide mechanical connection (by others) of truss to bearing plate capable of withstanding 53 lb uplift at joint 2, 233 lb uplift at joint 7, 21 lb uplift at joint 8, 95 lb uplift at joint 6 and 53 lb uplift at joint 2.
- 10) Graphical purlin representation does not depict the size or the orientation of the purlin along the top and/or bottom chord.

LOAD CASE(S) Standard

This item has been digitally signed and sealed by O'Regan, Philip, PE on the date indicated here. Printed copies of this document are not considered signed and sealed and the signature must be verified on any electronic copies.

Philip J. O'Regan PE No.58126
 MiTek Inc. DBA MiTek USA FL Cert 6634
 16023 Swingley Ridge Rd. Chesterfield, MO 63017
 Date:

February 23,2026

WARNING - Verify design parameters and READ NOTES ON THIS AND INCLUDED MITEK REFERENCE PAGE MII-7473 rev. 1/2/2023 BEFORE USE.

Design valid for use only with MiTek® connectors. This design is based only upon parameters shown, and is for an individual building component, not a truss system. Before use, the building designer must verify the applicability of design parameters and properly incorporate this design into the overall building design. Bracing indicated is to prevent buckling of individual truss web and/or chord members only. Additional temporary and permanent bracing is always required for stability and to prevent collapse with possible personal injury and property damage. For general guidance regarding the fabrication, storage, delivery, erection and bracing of trusses and truss systems, see ANSI/TPI1 Quality Criteria and DSB-22 available from Truss Plate Institute (www.tpinst.org) and BCSI Building Component Safety Information available from the Structural Building Component Association (www.sbcscomponents.com)

MiTek®
 16023 Swingley Ridge Rd.
 Chesterfield, MO 63017
 314.434.1200 / MiTek-US.com

Job 5263975	Truss V01	Truss Type Valley	Qty 1	Ply 1	Job Reference (optional)	T40209569
----------------	--------------	----------------------	----------	----------	--------------------------	-----------

Builders FirstSource (Lake City,FL), Lake City, FL - 32055.

Run: 8.83 S Jan 22 2026 Print: 8.830 S Jan 22 2026 MiTek Industries, Inc. Fri Feb 20 08:24:13
ID:4nJ8HYNspfg86Uhd2Ba0mgzjtMS-RIC?PsB70Hq3NSgPqnL8w3uITXbGKwRCdoi7J4zJC7f

Page: 1

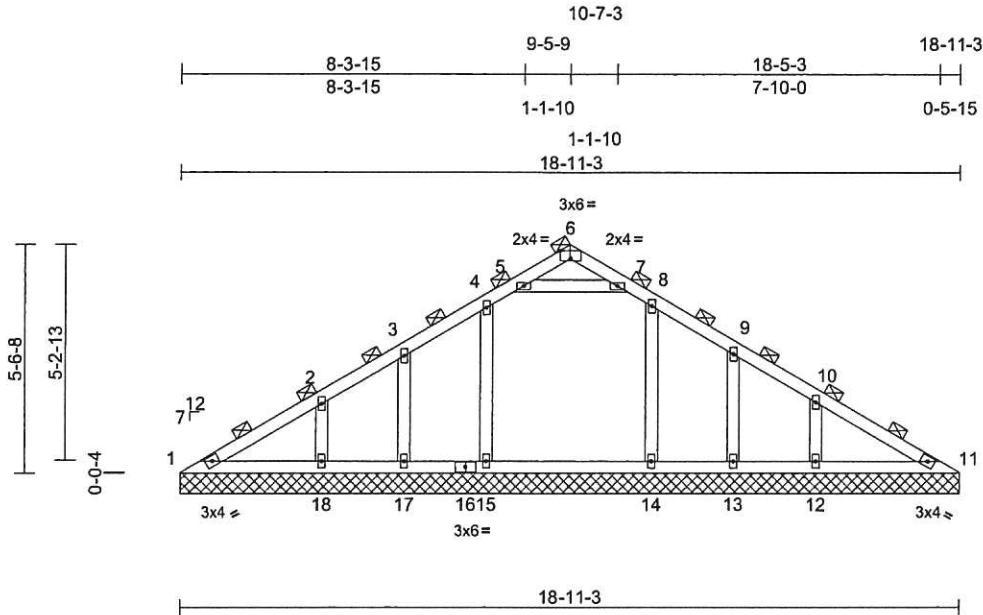

Scale = 1:56.1

Plate Offsets (X, Y): [6:0-3-0,Edge]

Loading	(psf)	Spacing	2-0-0	CSI	DEFL	in	(loc)	l/defl	L/d	PLATES	GRIP	
TCLL (roof)	20.0	Plate Grip DOL	1.25	TC	0.11	Vert(LL)	n/a	-	n/a	999	MT20	244/190
TCDL	10.0	Lumber DOL	1.25	BC	0.13	Vert(TL)	n/a	-	n/a	999		
BCLL	0.0*	Rep Stress Incr	YES	WB	0.07	Horiz(TL)	0.00	11	n/a	n/a		
BCDL	10.0	Code	FBC2023/TPI2014	Matrix-MS							Weight: 87 lb	FT = 20%

LUMBER

TOP CHORD 2x4 SP No.2
BOT CHORD 2x4 SP No.2
WEBS 2x4 SP No.3
OTHERS 2x4 SP No.3

BRACING

TOP CHORD 2-0-0 oc purlins (6-0-0 max.).
BOT CHORD Rigid ceiling directly applied or 6-0-0 oc bracing.

REACTIONS

(size) 1=18-11-3, 11=18-11-3,
12=18-11-3, 13=18-11-3,
14=18-11-3, 15=18-11-3,
17=18-11-3, 18=18-11-3
Max Horiz 1=-133 (LC 8)
Max Uplift 1=-22 (LC 13), 11=-6 (LC 13),
12=-115 (LC 13), 13=-68 (LC 13),
14=-31 (LC 13), 15=-53 (LC 12),
17=-65 (LC 12), 18=-115 (LC 12)
Max Grav 1=122 (LC 20), 11=113 (LC 1),
12=347 (LC 20), 13=101 (LC 20),
14=357 (LC 20), 15=380 (LC 19),
17=98 (LC 19), 18=344 (LC 19)

FORCES

(lb) - Maximum Compression/Maximum Tension
TOP CHORD 1-2=-183/124, 2-3=-70/79, 3-4=-47/95,
4-5=-67/102, 5-6=-134/41, 6-7=-135/41,
7-8=-67/102, 8-9=-30/74, 9-10=-37/44,
10-11=-155/89
BOT CHORD 1-18=-61/175, 17-18=-59/94, 15-17=-59/94,
14-15=-59/94, 13-14=-59/94, 12-13=-59/94,
11-12=-59/129
WEBS 4-15=-213/72, 3-17=-89/82, 2-18=-196/111,
8-14=-196/52, 9-13=-93/83, 10-12=-197/112,
5-7=-7/141

NOTES

1) Unbalanced roof live loads have been considered for this design.

- Wind: ASCE 7-22; Vult=130mph (3-second gust) Vasd=101mph; TCDL=4.2psf; BCDL=3.0psf; h=18ft; Cat. II; Exp B; Enclosed; MWFRS (envelope) exterior (2) zone and C-C Zone3 zone; C-C for members and forces & MWFRS for reactions shown; Lumber DOL=1.60 plate grip DOL=1.60
- Truss designed for wind loads in the plane of the truss only. For studs exposed to wind (normal to the face), see Standard Industry Gable End Details as applicable, or consult qualified building designer as per ANSI/TPI 1.
- Building Designer / Project engineer responsible for verifying applied roof live load shown covers rain loading requirements specific to the use of this truss component.
- All plates are 2x4 (||) MT20 unless otherwise indicated.
- Gable requires continuous bottom chord bearing.
- Gable studs spaced at 2-0-0 oc.
- This truss has been designed for a 10.0 psf bottom chord live load nonconcurrent with any other live loads.
- * This truss has been designed for a live load of 20.0psf on the bottom chord in all areas where a rectangle 3-06-00 tall by 2-00-00 wide will fit between the bottom chord and any other members, with BCDL = 10.0psf.
- Provide mechanical connection (by others) of truss to bearing plate capable of withstanding 22 lb uplift at joint 1, 6 lb uplift at joint 11, 53 lb uplift at joint 15, 65 lb uplift at joint 17, 115 lb uplift at joint 18, 31 lb uplift at joint 14, 68 lb uplift at joint 13 and 115 lb uplift at joint 12.
- Graphical purlin representation does not depict the size or the orientation of the purlin along the top and/or bottom chord.

LOAD CASE(S) Standard

This item has been digitally signed and sealed by O'Regan, Philip, PE on the date indicated here. Printed copies of this document are not considered signed and sealed and the signature must be verified on any electronic copies.

Philip J. O'Regan PE No.58126
MiTek Inc. DBA MiTek USA FL Cert 6634
16023 Swingley Ridge Rd. Chesterfield, MO 63017
Date:

February 23,2026

WARNING - Verify design parameters and READ NOTES ON THIS AND INCLUDED MITEK REFERENCE PAGE MII-7473 rev. 1/2/2023 BEFORE USE.

Design valid for use only with MiTek® connectors. This design is based only upon parameters shown, and is for an individual building component, not a truss system. Before use, the building designer must verify the applicability of design parameters and properly incorporate this design into the overall building design. Bracing indicated is to prevent buckling of individual truss web and/or chord members only. Additional temporary and permanent bracing is always required for stability and to prevent collapse with possible personal injury and property damage. For general guidance regarding the fabrication, storage, delivery, erection and bracing of trusses and truss systems, see ANSI/TPI1 Quality Criteria and DSB-22 available from Truss Plate Institute (www.tpinst.org) and BCSI Building Component Safety Information available from the Structural Building Component Association (www.sbcsccomponents.com)

MiTek®
16023 Swingley Ridge Rd.
Chesterfield, MO 63017
314.434.1200 MiTek-US.com

7/12 PITCH - 12" OH

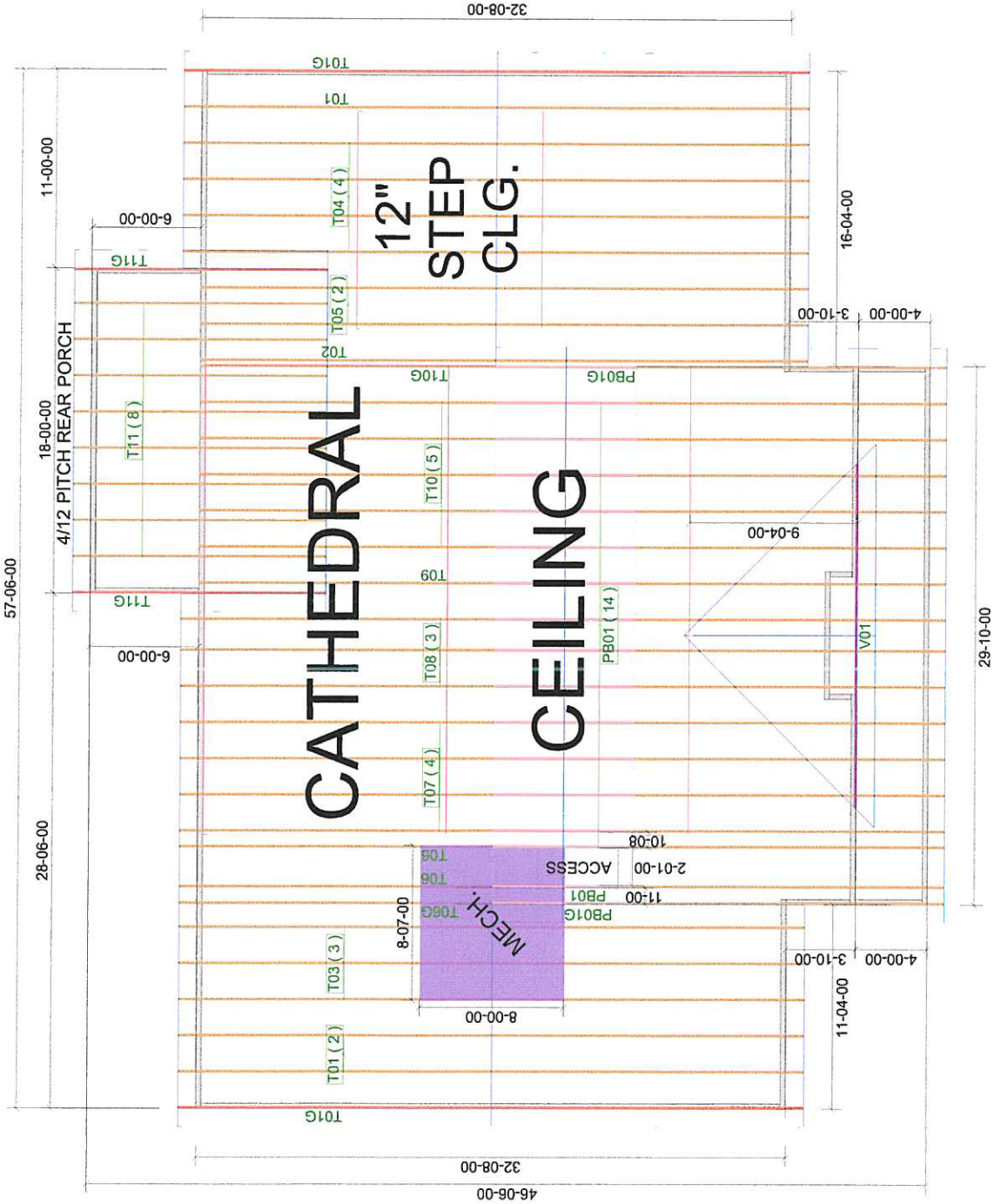

WARNING
 Backlogs Will Not Be Accepted
 Hours And Investigation By
 NO EXCEPTIONS.

IMPORTANT
 This Drawing Must Be Approved And
 Returned Before Fabrication Will
 Begin. For Your Protection Check All
 Dimensions And Conditions Prior To
 SIGNATURE BELOW INDICATES ALL
 NOTES AND DIMENSIONS HAVE
 BEEN ACCEPTED.

By _____ Date _____

FINAL LAYOUT FOR PRODUCTION
 Initial: _____ Date: _____
 Regulated Delivery Date: _____

FLOOR LAYOUT
 TOTAL AREA: 10,000 SQ FT
 TOTAL PERIMETER: 1,000 FT
 FOUNDATION: 1.5
 WALLS: 4.5
 ROOF: 1.5
 FINISH: 1.5
 TOTAL: 10,000 SQ FT
 USED TO PREP TRUCKY

ROOF PITCH: 7/12 - 4/12
 CEILING PITCH: 3.5/12
 TOP CHORD SIZE: 2 X 4
 BOTTOM CHORD SIZE: 2 X 4
 OVERHANG LENGTH: 12"
 END CUT: PLUMB
 CANTILEVER: N/A
 TRUSS SPACING: 24"
 BUILDING CODE: FBC-2023

BEARING HEIGHT SCHEDULE

BUILDER: CHRIS MILL HOMES, INC.
 MODEL: CUSTOM
 ELEV: GABLE
 ADDRESS: TBD
 LOT/BLOCK: N/A
 SUBDIVISION: WILSON PROPERTY
 CITY: White Springs
 DRAWN BY: Holloway, Kim
 JOB #: 5263715
 DATE: 12/20/2023 SCALE: N.T.S.

REVISIONS



Summations of limited excerpts of the Code, ANSITPI 1-2014, and BCSI, and associated commentary, are provided within the truss submittal package in the Builders FirstSource Component Truss Responsibility and Liability Disclosure. These critical excerpts include, among other elements, critical safety information as well as specific Scope-of-Work assignments (and limitations of the same) for the Owner, Contractor, Building Designer, Truss Designer, and Truss Manufacturer. It is essential that ALL parties to the design and use of the Trusses review and become familiar with the information provided in the Builders FirstSource Component Truss Responsibility and Liability Disclosure, as well as the referenced sources, prior to performing work on the associated project.