

BUILDING CHARACTERISTICS		
ELEMENT	CD	CONSTRUCTION
Exterior Wall	19	COMMON BRK 100
Roof Structur	08	IRREGULAR 100
Roof Cover	03	COMP SHNGL 100
Interior Wall	05	DRYWALL 100
Interior Floo	14	CARPET 70
Interior Floo	15	HARDTILE 30
Air Condition	03	CENTRAL 100
Heating Type	04	AIR DUCTED 100
Bedrooms		3 100
Bathrooms		2 100
Frame	01	NONE 100
Stories	1.	1. 100
Architectual	05	CONV 100
Units		0 100
Condition Adj	03	03 100
Kitchen Adjus	01	01 100

MARKET ADJUSTMENTS											
TYPE	MDL	EFF. AREA	TOT ADJ PTS	EFF. BASE RATE	REPL. COST NEW	AYB	EYB	ECON	FNCT	NORM	% COND
1	SINGLE FAM	100%	2007								
				Heated Area:	3383			HX Base Yr	2007		

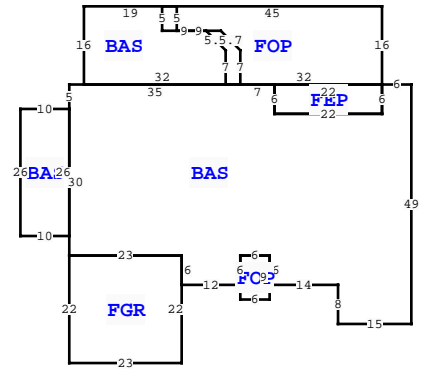
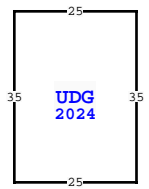

Quality	06	06			
DOR CODE	0100	SINGLE FAMILY			
MAP NUM		MKT AREA 06			
NEIGHBORHOOD/LOC	10416.010	1.00/			
AREA TYPE	TOTAL GROSS AREA	PCT OF BASE	YEAR	TOT ADJ AREA	SUBAREA MARKET VALUE
BAS	260	100		260	24,954
BAS	439	100		439	42,134
BAS	2,684	100		2,684	257,605
FEP	132	80		106	10,174
FGR	506	55		278	26,682
FOP	54	30		16	1,536
FOP	585	30		176	16,892
UDG	875	55	2024	481	46,166
TOTALS	5,535			4,440	426,142

COLUMBIA COUNTY PROPERTY			PAGE 1 of 1	3
VALUATION SUMMARY			STANDARD	
VALUATION BY			STANDARD	
Tax Group: 3	Tax Dist:			
BUILDING MARKET VALUE			426,142	
TOTAL MARKET OB/XF VALUE			10,237	
TOTAL LAND VALUE - MARKET			35,000	
TOTAL MARKET VALUE			471,379	
SOH/AGL Deduction			152,043	
ASSESSED VALUE			319,336	
TOTAL EXEMPTION VALUE	HX HB VX		55,722	
BASE TAXABLE VALUE			263,614	
TOTAL JUST VALUE			471,379	
NCON VALUE			0	
INCOME VALUE				
PREVIOUS YEAR MKT VALUE			477,438	

PERMIT NUM	DESCRIPTION	AMT	ISSUED
28799	ADDN SFR	449	08/18/2010
15567	GARAGE	50	05/25/1999
14831	SFR	395	12/09/1998

SALES DATA						
OFF RECORD Number	DATE	TYPE INST	Q / U	V / I	RSN CD	SALE PRICE
1082/1813	4/27/2006	WD	Q	I		330,000
GRANTOR: LEWIS & BOBBIE MCCLLEL						
GRANTEE: STEPHEN & MARIA R P						
0880/0670	5/09/1999	WD	Q	I		151,900
GRANTOR: J JOHNSON						
GRANTEE: LEWIS & BOBBIE MCCL						

EXTRA FEATURES																	
L N	OB/XF CODE	DESCRIPTION	BLD	CAP	L	W	UNITS	UT	Adj R	ADJ UNIT PRICE	ORIG COND	YEAR ON	YEAR ACTUAL	Q	% COND	OB/XF MKT VALUE	NOTES
1	0120	CLFENCE 4	0	100	0	0	530.00	UT	2.50	2.50	100	1999	1999	3	100	1,325	
2	0166	CONC, PAVMT	0	100	0	0	2,541.00	UT	1.50	1.50	100	1999	1999	3	100	3,812	
3	0104	GENERATOR	0	100	0	0	1.00	UT	6,000.00	6,000.00	100	2024	2023		85	5,100	

120 SW PLATINUM GLN, LAKE CITY				BLD DATE		LGL DATE	
				XF DATE		LAND DATE	04/03/2025
				INC DATE		AG DATE	MLU

BUILDING NOTES											
----------------	--	--	--	--	--	--	--	--	--	--	--

BUILDING DIMENSIONS											
BAS=[ORIG=0,0] W6 S6 W22 N6 W7 W35 S5 S30 E23 S6 E12 N6 E6 S6 E14 S8 E15 N49 \$											
UDG=[YR=2024;ORIG=-185,-60] E25 S35 W25 N35 \$											
FOP=[ORIG=-6,0] N16 W45 S5 E9 D4R4 S7 E32 \$											
FGR=[ORIG=-70,35] S22 E23 N22 W23 \$											
BAS=[ORIG=-35,0] N7 U4L4 W9 N5 W19 S16 E32 \$											
BAS=[ORIG=-70,5] W10 S26 E10 N26 \$											
FEP=[ORIG=-6,0] W22 S6 E22 N6 \$											
POP=[ORIG=-35,41] S3 E6 N9 W6 S6 \$											
PTR=[ORIG=0,0] N30 S30 \$											

LAND DESCRIPTION												TOTAL OB/XF											
L N	USE CODE	CLS	LAND USE DESCRIPTION	CAP	R D	LOC ZONE	FRONT	DEPTH	TOT LND UTS	UNIT TYPE	D T	% COND	TOT ADJ	UNIT PRICE	ADJ UNIT PRICE	LAND VALUE	OTHER ADJUSTMENTS AND NOTES	YEAR	DENSITY	DECL	FRZ	YR	CONSRV
1	0100	C	SFR	100		RSF-1	0.00	0.00	1.00	LT		1.00	1.00	35,000.00	35,000.00	35,000							