

Piggyback Detail - ASCE 7-16: 180 mph, 30' Mean Hgt, Partially Enclosed, Exp. C, Kzt=1.00

180 mph Wind, 30,000 ft Mean Hgt, ASCE 7-16, Part, Enclosed Bldg, located anywhere in roof, Exp C, Wind DL= 5.0 psf (min), Kzt=1.0, Dr 160 mph wind, 30,000 ft Mean Hgt, ASCE 7-16, Part, Enclosed Bldg, located anywhere in roof, Exp D, Wind DL= 5.0 psf (min), Kzt=1.0.

Note: Top chords of trusses supporting piggyback cap trusses must be adequately braced by sheathing or purlins. The building Engineer of Record shall provide diagonal bracing or any other suitable anchorage to permanently restrain purlins, and lateral bracing for out of plane loads over gable ends. Maximum truss spacing is 24' o.c. detail is not applicable if cap supports additional loads such as cupola, steeple, chimney or drag strut loads.

See Refer to Engineer's sealed truss design drawing for piggyback and base truss specifications.

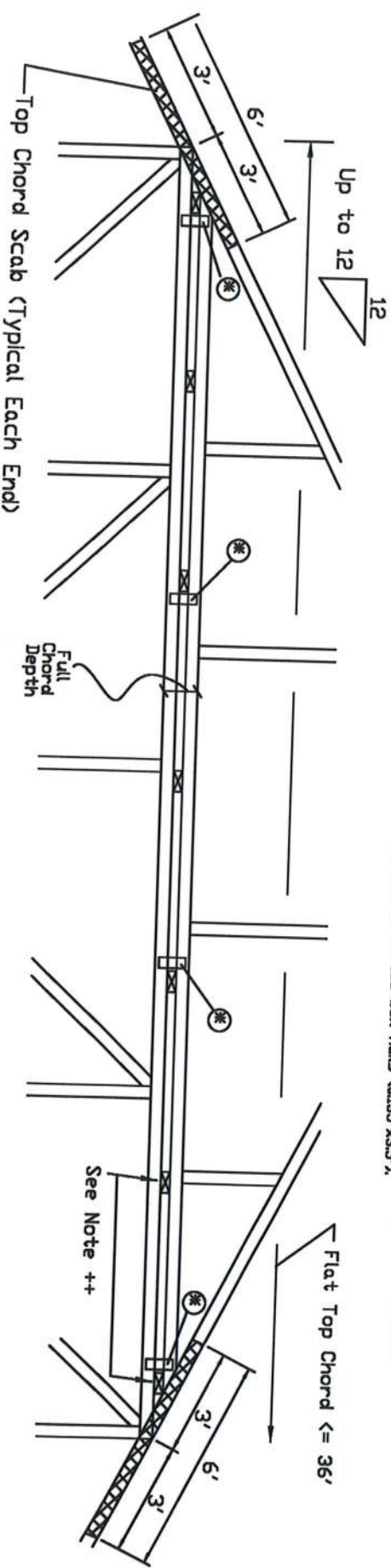

Piggyback cap truss slant nailed to all top chord purlin bracing with (2) 16d box nails (0.128x3.57) and secure top chord with 2x4 #3 grade scab (1 side only at each end) attached with 2 rows of 16d box nails (0.128x3.57) at 4' o.c.

++ Flat top chord purlins required at both ends and at a maximum of 24' intervals unless otherwise noted on base truss design drawing. Attach purlin bracing to the flat top chord using a minimum of (2) 16d box nails (0.128x3.57).

In addition, provide connection with one of the following methods

<p>Trulox</p> <p>Use 3X8 Trulox plates for 2x4 chord member, and members. Attach to each face @ 8' o.c. with (4) 0.120"x1.375" nails into cap bottom chord and (4) in base truss top chord. Trulox plates may be staggered 4' o.c. front to back faces.</p>	<p>2BPB Wave Piggyback Plate</p> <p>One 2BPB wave piggyback plate to each face @ 8' o.c. Attach each side to piggyback at time of fabrication. Attach to supporting truss with (4) 0.120"x1.375" nails per face per ply. Piggyback plates may be staggered 4' o.c. front to back faces.</p>
<p>APA Rated Gussset</p> <p>8"x8"x1/16" (min) APA rated sheathing gusssets (G953 face). Attach @ 8' o.c. with (8) 5d common (0.113"x2") nails per gussset, (4) in cap bottom chord and (4) in base truss top chord. Gusssets may be staggered 4' o.c. front to back faces.</p>	<p>2x4 Vertical Scabs</p> <p>2x4 SPF #2, full chord depth scabs (each face). Attach @ 8' o.c. with (6) 16d box nails (0.128"x3.57) per scab, (3) per cap bottom chord and (3) in base truss top chord. Scabs may be staggered 4' o.c. front to back faces.</p>

MANUFACTURER READ AND FOLLOW ALL NOTES ON THIS DRAWING

INDUSTRY PRACTICES TO ALL CONTRACTORS INCLUDING THE INSTALLER. Trusses require extreme care in handling, shipping, installing and bracing. See the latest edition of ASCE 7-16 for details. Components shall be installed in accordance with the manufacturer's instructions. Trusses shall be installed in accordance with the manufacturer's instructions. Trusses shall be installed in accordance with the manufacturer's instructions. Trusses shall be installed in accordance with the manufacturer's instructions.

Professional Engineer Seal: DONALD W. KING, No. 66648, STATE OF FLORIDA, PROFESSIONAL ENGINEER. License No. 081026340-278.

REF	PIGGYBACK
DATE	01/02/2018
DRWG	PB180160118

155 Harten Ave
North Building, 4th Floor
Glenview, IL 60025

SPACING	24.0'
---------	-------

Cracked or Broken Member Repair Detail

This drawing specifies repairs for a truss with broken chord or web member.

This design is valid only for single ply trusses with 2x4 or 2x6 broken members. No more than one break per chord panel and no more than two breaks per truss are allowed. Contact the truss manufacturer for any repairs that do not comply with this detail.

- (B) = Damaged area, 12' max length of damaged section
- (L) = Minimum nailing distance on each side of damaged area (B)
- (S) = Two 2x4 or two 2x6 side members, same size, grade, and species as damaged member. Apply one scab per face. Minimum side member length(s) = (2)(L) + (B)

Scab member length (S) must be within the broken panel.
 Nail into 2x4 members using two (2) rows at 4' o.c., rows staggered.
 Nail into 2x6 members using three (3) rows at 4' o.c., rows staggered.
 Nail using 10d box or gun nails (0.128"x3", min) into each side member.
 The maximum permitted lumber grade for use with this detail is limited to Visual grade #1 and MSR grade 1650f.
 This repair detail may be used for broken connector plate at mid-panel splices.

This repair detail may not be used for damaged chord or web sections occurring within the connector plate area.
 Broken chord may not support any tie-in loads.

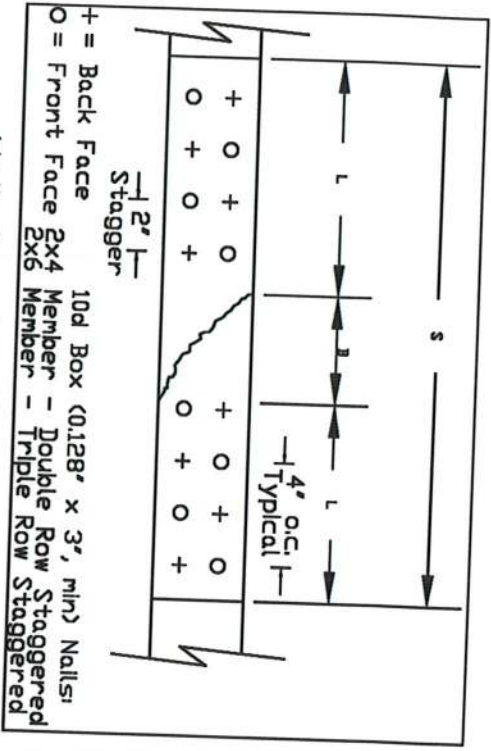

Nail Spacing Detail

Load Duration = 0%
 Member forces may be increased for Duration of Load

Member	Size	L	Maximum Member Axial Force			
			SPF-C	HF	DF-L	SYP
Web Only	2x4	12'	620#	635#	730#	800#
Web Only	2x4	18'	975#	1055#	1295#	1415#
Web or Chord	2x4	24'	975#	1055#	1495#	1745#
Web or Chord	2x4	30'	1465#	1585#	2245#	2620#
Web or Chord	2x4	36'	1910#	1960#	2315#	2555#
Web or Chord	2x6	36'	2230#	2365#	3125#	3575#
Web or Chord	2x4	36'	2470#	2530#	2930#	3210#
Web or Chord	2x6	42'	3535#	3635#	4295#	4745#
Web or Chord	2x6	42'	2975#	3045#	3505#	3835#
Web or Chord	2x4	48'	4395#	4500#	5225#	5725#
Web or Chord	2x4	48'	3460#	3540#	4070#	4445#
Web or Chord	2x6	48'	5165#	5280#	6095#	6660#

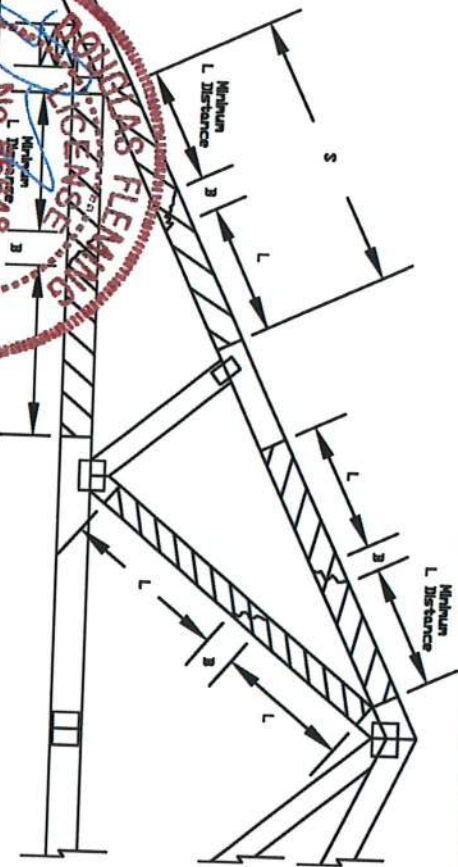

155 Harlem Ave
 North Building, 4th Floor
 Glenview, IL 60025

TRUSSES require extreme care in fabricating, handling, shipping, installing and bracing. Best practices prior to performing these functions are to consult with the truss manufacturer. Truss manufacturers noted elsewhere, top chord shall have properly attached rigid ceiling. Locations shown for repair of truss and possibly other members shall be as shown on the job. Refer to drawings 150A-2 for member and on the job details, unless noted otherwise.
 Alpha, a division of TTV Building Components Group Inc. shall not be responsible for any deviations from this drawing, any failure of the truss in connection with this drawing, or for handling, shipping, installation & bracing of trusses.
 For more information see the job's general notes page and these notes attached to this drawing or cover page listing this drawing, including acceptance of professional responsibility and seal of the designer.
 For more information see the job's general notes page and these notes attached to this drawing or cover page listing this drawing, including acceptance of professional responsibility and seal of the designer.
 ALPINE ANTIM COMPANY 1700 W. Spanglers Ln, Suite 200, Schaumburg, IL 60196



REF	MEMBER REPAIR
DATE	10/01/14
DRWG	REPCHRD1014

SPACING 24.0' MAX

Gable Stud Reinforcement Detail

ASCE 7-16: 140 mph Wind Speed, 30' Mean Height, Enclosed, Exposure C, Kzt = 1.00

Drn 120 mph Wind Speed, 30' Mean Height, Partially Enclosed, Exposure C, Kzt = 1.00

Dm 120 mph Wind Speed, 30' Mean Height, Enclosed, Exposure D, Kzt = 1.00

Dm 100 mph wind speed, 30' Mean Height, Partially Enclosed, Exposure D, Kzt = 1.00

Gable Vertical Spacing	2x4 Vertical Species	Brace Grade	No Braces	Group A			Group B			Group C		
				12" o.c.	16" o.c.	24" o.c.	12" o.c.	16" o.c.	24" o.c.	12" o.c.	16" o.c.	24" o.c.
12" o.c.	SPF	#1 / #2	4' 1"	6' 11"	7' 2"	8' 2"	8' 6"	9' 9"	10' 2"	12' 10"	13' 4"	14' 0"
		#3	3' 10"	6' 2"	6' 7"	8' 1"	8' 5"	9' 8"	10' 0"	12' 8"	13' 2"	14' 0"
		Standard	3' 10"	5' 3"	5' 7"	7' 0"	7' 6"	9' 6"	10' 0"	11' 0"	11' 0"	14' 0"
	HF	#1	4' 2"	7' 0"	7' 3"	8' 3"	8' 7"	9' 10"	10' 3"	13' 0"	13' 6"	14' 0"
		#2	4' 1"	4' 0"	5' 7"	7' 2"	8' 2"	8' 6"	9' 9"	12' 10"	13' 4"	14' 0"
		#3	4' 0"	4' 0"	5' 7"	7' 11"	7' 5"	8' 9"	9' 8"	10' 1"	11' 7"	12' 5"
	DFL	Standard	4' 0"	4' 0"	5' 7"	7' 7"	7' 5"	9' 8"	9' 8"	10' 1"	11' 7"	12' 5"
		#1 / #2	3' 9"	4' 11"	5' 13"	6' 4"	7' 0"	8' 10"	9' 6"	10' 3"	11' 0"	13' 11"
		#3	4' 8"	4' 5"	7' 11"	8' 3"	9' 4"	9' 9"	11' 2"	11' 7"	14' 0"	14' 0"
	SPF	Standard	4' 5"	4' 5"	7' 6"	8' 0"	9' 3"	9' 7"	11' 0"	11' 6"	14' 0"	14' 0"
		#1	4' 10"	8' 0"	8' 4"	9' 6"	9' 10"	11' 3"	11' 9"	14' 0"	14' 0"	14' 0"
		#2	4' 8"	4' 8"	7' 11"	8' 3"	9' 4"	9' 9"	11' 2"	11' 7"	14' 0"	14' 0"
DFL	Standard	4' 7"	4' 7"	6' 10"	7' 3"	9' 1"	9' 8"	11' 1"	11' 6"	14' 0"	14' 0"	
	#1 / #2	4' 5"	6' 0"	6' 5"	8' 0"	8' 7"	10' 10"	11' 6"	12' 7"	13' 15"	14' 0"	
	#3	5' 2"	8' 9"	9' 1"	10' 4"	10' 9"	11' 2"	12' 9"	14' 0"	14' 0"	14' 0"	
HF	Standard	4' 10"	8' 7"	8' 11"	10' 2"	10' 7"	12' 2"	12' 8"	14' 0"	14' 0"	14' 0"	
	#1	4' 10"	7' 5"	7' 11"	10' 7"	10' 7"	12' 2"	12' 8"	14' 0"	14' 0"	14' 0"	
	#2	5' 4"	8' 10"	9' 2"	10' 5"	10' 10"	12' 5"	12' 11"	14' 0"	14' 0"	14' 0"	
SP	Standard	5' 2"	8' 9"	9' 1"	10' 4"	10' 9"	12' 3"	12' 9"	14' 0"	14' 0"	14' 0"	
	#1	5' 0"	7' 10"	8' 4"	10' 3"	10' 8"	12' 2"	12' 8"	14' 0"	14' 0"	14' 0"	
	#3	5' 0"	7' 10"	8' 4"	10' 3"	10' 8"	12' 2"	12' 8"	14' 0"	14' 0"	14' 0"	
DFL	Standard	4' 10"	6' 11"	7' 4"	9' 3"	9' 10"	12' 2"	12' 8"	14' 0"	14' 0"	14' 0"	
	#1 / #2	4' 10"	8' 7"	8' 11"	10' 2"	10' 7"	12' 2"	12' 8"	14' 0"	14' 0"	14' 0"	
	#3	4' 10"	8' 7"	8' 11"	10' 2"	10' 7"	12' 2"	12' 8"	14' 0"	14' 0"	14' 0"	

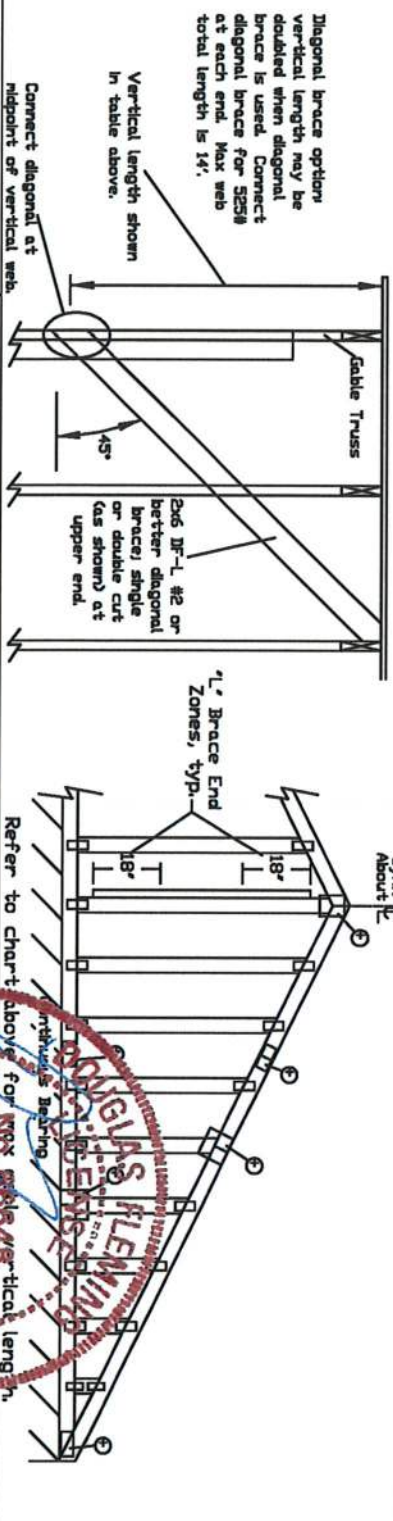

ALPINE ANTIW COMPANY
 155 Harmon Ave
 North Building, 4th Floor
 Glenview, IL 60025

STATE OF FLORIDA PROFESSIONAL ENGINEER
 05102400000278

Diagonal brace options: vertical length may be doubled when diagonal brace is used. Connect diagonal brace for S2S# at each end. Max web total length is 14'.

Vertical length shown in table above.

Connect diagonal at midpoint of vertical web.

Refer to chart above for max. gable length.

MAX. TOT. LD. 60 PSF
 MAX. SPACING 24'0"

Bracing Group Species and Grades	
Group A1	Her-Fr #1 / #2 Standard Stud #3 Standard
Group B1	Her-Fr #1 & Btr #1
Group C1	Southern Pineam #1 #2

1x4 Braces shall be SRB (Stress-Rated Board) or 1x4 So. Pine use only Industrial SS or Industrial 4S Stress-Rated Boards. Group B values may be used with these grades.

Gable Truss Detail Notes:
 Wind load deflection criterion is L/240.
 Provide uplift connections for 100 psf over continuous bearing GS perf TC Dead Load.
 Gable end supports load from 4' 0" overhangs with 2' 0" overhang, or 12" plywood overhang.

Gable Vertical Plate Sizes	
Vertical Length	No Splice
Less than 4' 0"	2X4
Greater than 4' 0", but less than 11' 6"	3X4
Greater than 11' 6"	4X4

Refer to the Building Designer for conditions not addressed by this detail.

Attach 1" L' braces with 10d (128x3d) nh) nails.
 * For CD 1" brace space nails at 2' o.c. in 18" end zones and 4' o.c. between zones.
 * For CD 1" braces space nails at 3' o.c. in 18" end zones and 6' o.c. between zones.
 L' bracing must be a minimum of 80% of web member length.

Refer to the Building Designer for conditions not addressed by this detail.

REF ASCE7-16-GAB14030
 DATE 01/26/2018
 DRWG A14030ENC160118

CLR Reinforcing Member Substitution

This detail is to be used when a Continuous Lateral Restraint (CLR) is specified on a truss design but an alternative web reinforcement method is desired.

Notes:

This detail is only applicable for changing the specified CLR shown on single ply sealed designs to T-reinforcement or L-reinforcement or scab reinforcement.

Alternative reinforcement specified in chart below may be conservative. For minimum alternative reinforcement, re-run design with appropriate reinforcement type.

Use scabs instead of L- or T- reinforcement on webs with intersecting truss joints, such as K-web joints, that may interfere with proper application along the narrow face of the web.

Web Member Size	Specified CLR Restraint	Alternative Reinforcement T- or L- Reinf.	Scab Reinf.
2x3 or 2x4	1 row	2x4	1-2x4
2x3 or 2x4	2 rows	2x6	2-2x4
2x6	1 row	2x4	1-2x6
2x6	2 rows	2x6	2-2x4 Q
2x8	1 row	2x6	1-2x8
2x8	2 rows	2x6	2-2x6 Q

T-reinforcement, L-reinforcement, or scab reinforcement to be same species and grade or better than web member unless specified otherwise on Engineer's sealed design.

~~Q~~ Center scab on wide face of web. Apply (1) scab to each face of web.

T-Reinforcement
OR
L-Reinforcement:

Apply to either side of web narrow face. Attach with 10d (0.128"x3.0" min) nails at 6" o.c. Reinforcing member is a minimum 80% of web member length.

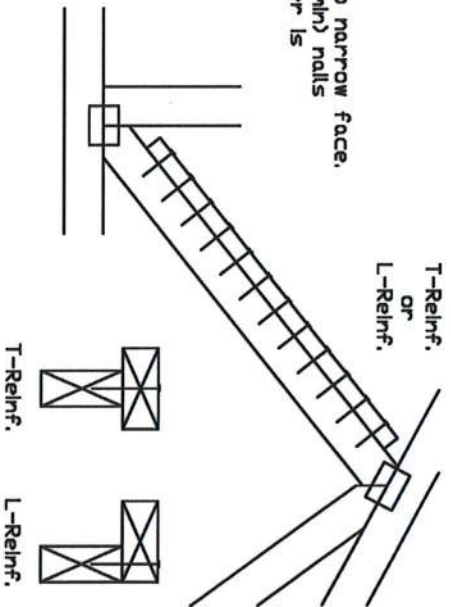

Scab Reinforcement:

Apply scab(s) to wide face of web. No more than (1) scab per face. Attach with 10d (0.128"x3.0" min) nails at 6" o.c. Reinforcing member is a minimum 80% of web member length.

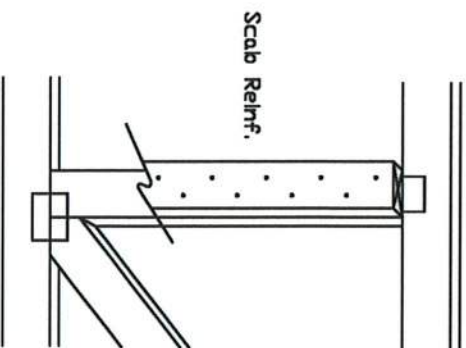

IMPORTANT: READ AND FOLLOW ALL NOTES ON THIS DRAWING

Trusses require extreme care in fabrication, handling, shipping, handling and bracing. Refer to the latest edition of AISC's Building Component Safety Information, by ITI and SCSO for details. Practices prior to performing these functions. Installers shall provide temporary bracing and bracing noted otherwise. Top chord shall have properly attached structural sheathing and bottom chord shall have a properly attached rigid diaphragm. Locations shown for permanent lateral restraint of trusses are not intended to be used as the sole lateral restraint. Refer to drawings 100A-2 for standard plate positions.

Alpha, a division of ITW Building Components Group Inc. shall not be responsible for any deviation from this drawing, any failure to build the truss in conformance with AISC/ITI's, or for handling, shipping, installation & bracing of trusses. A seal on this drawing or cover page listing this drawing, indicates acceptance of professional engineering responsibility solely for the design shown. The authority and use of this drawing for any structure is the responsibility of the building designer per AISC/ITI 1.3(c)(2).

For more information see this job's general notes page and those with them. ALPHAD 05/02/2012 05:02:22



TC LL	PSF	REF	CLR Subst.
TC DL	PSF	DATE	01/02/19
BC DL	PSF	DRWG	BRCLBSUB0119
BC LL	PSF		
TOT. LD.	PSF		
DUR. FAC.			
SPACING			



155 Harlem Ave
North Building, 4th Floor
Glenview, IL 60025

ALL WALLS SHOWN TO BE BEARING
 AMERICA'S HOME PLACE, INC.
 FLATT RESIDENCE ~ UNION-MFH

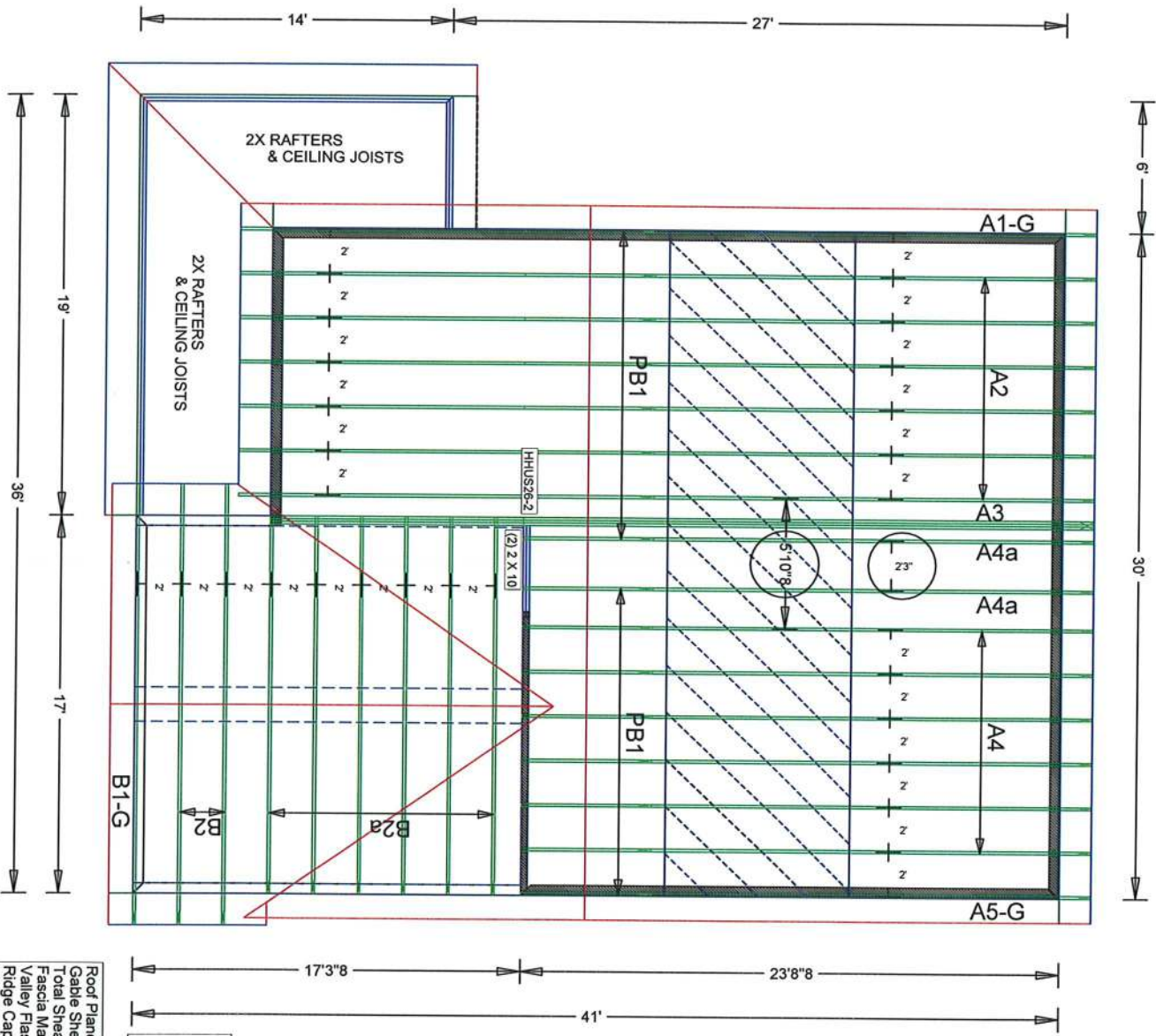

Root Plane Sheathing Area = 1807 sq. ft
 Gable Sheathing Area = 495 sq. ft
 Total Sheathing Area = 2262 sq. ft
 Fascia Material = 94 linear ft
 Valley Flashing Material = 38 linear ft
 Ridge Cap Material = 52 linear ft
 Hip Ridge Material = 11 linear ft

SEMINOLE TRUSSES INC.
 30726 Bluestar Memorial Hwy.
 MIDWAY, FL 32343
 Phone (850) 575-0102
 Fax (850) 575-4413
 Design By Robert J. Little



This document has been electronically signed and sealed using a Digital Signature. Printed copies without an original signature must be verified using the original electronic version.



COA #0 278
 Florida Certificate of Product Approval #FL1999
 05/02/2022

Alpine, an ITW Company
 155 Harlem Ave
 North Building, 4th Floor
 Glenview, IL 60025
 Phone: (800)755-6001
 www.alpineitw.com

Site Information:	Page 1:
Customer: Seminole Trusses, Inc.	Job Number: B55473a
Job Description: FLATT RESIDENCE	
Address: 236 SW NEBRASKA TER., FORT WHITE, FL 32038	

Job Engineering Criteria:	
Design Code: FBC 7th Ed. 2020 Res.	IntelliVIEW Version: 21.01.03A
Wind Standard: ASCE 7-16 Wind Speed (mph): 130	JRef #: 1Xf78570003
Building Type: Closed	Design Loading (psf): 37.00

This package contains general notes pages, 10 truss drawing(s) and 7 detail(s).

Item	Drawing Number	Truss
1	122.22.1548.23670	A1-G 35' Gable
3	122.22.1549.06523	A3 35' Common Girder
5	122.22.1549.14397	A4a 23'8"8 Common
7	122.22.1549.18820	B1-G 17' Gable
9	122.22.1548.49543	B2a 17' Common
11	A14015ENC160118	
13	PB160160118	
15	REPCHRD1014	
17	BRCLBSUB0119	

Item	Drawing Number	Truss
2	122.22.1548.25127	A2 35' Common
4	122.22.1549.10577	A4 23'8"8 Common
6	122.22.1549.15913	A5-G 23'8"8 Gable
8	122.22.1548.47283	B2 17' Common
10	122.22.1548.51233	PB1 5'9"2 Common
12	GBLLETIN0118	
14	PB180160118	
16	A14030ENC160118	

General Notes

Truss Design Engineer Scope of Work, Design Assumptions and Design Responsibilities:

The design responsibilities assumed in the preparation of these design drawings are those specified in ANSI/TPI 1, Chapter 2; and the National Design Standard for Metal Plate Connected Wood Truss Construction, by the Truss Plate Institute. The truss component designs conform to the applicable provisions of ANSI/TPI 1 and NDS, the National Design Specification for Wood Construction by AWC. The truss component designs are based on the specified loading and dimension information furnished by others to the Truss Design Engineer. The Truss Design Engineer has no duty to independently verify the accuracy or completeness of the information provided by others and may rely on that information without liability. The responsibility for verification of that information remains with others neither employed nor controlled by the Truss Design Engineer. The Truss Design Engineer's seal and signature on the attached drawings, or cover page listing these drawings, indicates acceptance of professional engineering responsibility solely for the truss component designs and not for the technical information furnished by others which technical information and consequences thereof remain their sole responsibility.

The suitability and use of these drawings for any particular structure is the responsibility of the Building Designer in accordance with ANSI/TPI 1 Chapter 2. The Building Designer is responsible for determining that the dimensions and loads for each truss component match those required by the plans and by the actual use of the individual component, and for ascertaining that the loads shown on the drawings meet or exceed applicable building code requirements and any additional factors required in the particular application. Truss components using metal connector plates with integral teeth shall not be placed in environments that will cause the moisture content of the wood in which plates are embedded to exceed 19% and/or cause corrosion of connector plates and other metal fasteners.

The Truss Design Engineer shall not be responsible for items beyond the specific scope of the agreed contracted work set forth herein, including but not limited to: verifying the dimensions of the truss component, calculation of any of the truss component design loads, inspection of the truss components before or after installation, the design of temporary or permanent bracing and their attachment required in the roof and/or floor systems, the design of diaphragms or shear walls, the design of load transfer connections to and from diaphragms and shear walls, the design of load transfer to the foundation, the design of connections for truss components to their bearing supports, the design of the bearing supports, installation of the truss components, observation of the truss component installation process, review of truss assembly procedures, sequencing of the truss component installation, construction means and methods, site and/or worker safety in the installation of the truss components and/or its connections.

This document may be a high quality facsimile of the original engineering document which is a digitally signed electronic file with third party authentication. A wet or embossed seal copy of this engineering document is available upon request.

Temporary Lateral Restraint and Bracing:

Temporary lateral restraint and diagonal bracing shall be installed according to the provisions of BCSI chapters B1, B2, B7 and/or B10 (Building Component Safety Information, by TPI and SBCA), or as specified by the Building Designer or other Registered Design Professional. The required locations for lateral restraint and/or bracing depicted on these drawings are only for the permanent lateral support of the truss members to reduce buckling lengths, and do not apply to and may not be relied upon for the temporary stability of the truss components during their installation.

Permanent Lateral Restraint and Bracing:

The required locations for lateral restraint or bracing depicted on these drawings are for the permanent lateral support of the truss members to reduce buckling lengths. Permanent lateral support shall be installed according to the provisions of BCSI chapters B3, B7 and/or B10, or as specified by the Building Designer or other Registered Design Professional. These drawings do not depict or specify installation/erection bracing, wind bracing, portal bracing or similar building stability bracing which are parts of the overall building design to be specified, designed and detailed by the Building Designer.

Connector Plate Information:

Alpine connector plates are made of ASTM A653 or ASTM A1063 galvanized steel with the following designations, gauges and grades: W=Wave, 20ga, grade 40; H=High Strength, 20ga, grade 60; S=Super Strength, 18ga, grade 60. Information on model code compliance is contained in the ICC Evaluation Service report ESR-1118, available on-line at www.icc-es.org.

Fire Retardant Treated Lumber:

Fire retardant treated lumber must be properly re-dried and maintained below 19% or less moisture level through all stages of construction and usage. Fire retardant treated lumber may be more brittle than untreated lumber. Special handling care must be taken to prevent breakage during all handling activities.

General Notes (continued)

Key to Terms:

Information provided on drawings reflects a summary of the pertinent information required for the truss design. Detailed information on load cases, reactions, member lengths, forces and members requiring permanent lateral support may be found in calculation sheets available upon written request.

BCDL = Bottom Chord standard design Dead Load in pounds per square foot.

BCLL = Bottom Chord standard design Live Load in pounds per square foot.

CL = Certified lumber.

Des Ld = total of TCLL, TCDL, BCLL and BCDL Design Load in pounds per square foot.

FRT = Fire Retardant Treated Lumber.

FRT-DB = D-Blaze Fire Retardant Treated lumber.

FRT-DC = Dricon Fire Retardant Treated lumber.

FRT-FP = FirePRO Fire Retardant Treated lumber.

FRT-FL = FlamePRO Fire Retardant Treated lumber.

FRT-FT = FlameTech Fire Retardant Treated lumber.

FRT-PG = PYRO-GUARD Fire Retardant Treated lumber.

g = green lumber.

HORZ(LL) = maximum Horizontal panel point deflection due to Live Load, in inches.

HORZ(TL) = maximum Horizontal panel point long term deflection in inches, due to Total Load, including creep adjustment.

HPL = additional Horizontal Load added to a truss Piece in pounds per linear foot or pounds.

Ic = Incised lumber.

FJ = Finger Jointed lumber.

L/# = user specified divisor for limiting span/deflection ratio for evaluation of actual L/defl value.

L/defl = ratio of Length between bearings, in inches, divided by the vertical Deflection due to creep, in inches, at the referenced panel point. Reported as 999 if greater than or equal to 999.

Loc = Location, starting location of left end of bearing or panel point (joint) location of deflection.

Max BC CSI = Maximum bending and axial Combined Stress Index for Bottom Chords for of all load cases.

Max TC CSI = Maximum bending and axial Combined Stress Index for Top Chords for of all load cases.

Max Web CSI = Maximum bending and axial Combined Stress Index for Webs for of all load cases.

NCBCLL = Non-Concurrent Bottom Chord design Live Load in pounds per square foot.

PL = additional Load applied at a user specified angle on a truss Piece in pounds per linear foot or pounds.

PLB = additional vertical load added to a Bottom chord Piece of a truss in pounds per linear foot or pounds

PLT = additional vertical load added to a Top chord Piece of a truss in pounds per linear foot or pounds.

PP = Panel Point.

R = maximum downward design Reaction, in pounds, from all specified gravity load cases, at the indicated location (Loc).

-R = maximum upward design Reaction, in pounds, from all specified gravity load cases, at the identified location (Loc).

Rh = maximum horizontal design Reaction in either direction, in pounds, from all specified gravity load cases, at the indicated location (Loc).

RL = maximum horizontal design Reaction in either direction, in pounds, from all specified non-gravity (wind or seismic) load cases, at the indicated location (Loc).

Rw = maximum downward design Reaction, in pounds, from all specified non-gravity (wind or seismic) load cases, at the identified location (Loc).

TCDL = Top Chord standard design Dead Load in pounds per square foot.

TCLL = Top Chord standard design Live Load in pounds per square foot.

U = maximum Upward design reaction, in pounds, from all specified non-gravity (wind or seismic) load cases, at the indicated location (Loc).

VERT(CL) = maximum Vertical panel point deflection in inches due to Live Load and Creep Component of Dead Load in inches.

VERT(CTL) = maximum Vertical panel point deflection ratios due to Live Load and Creep Component of Dead Load, and maximum long term Vertical panel point deflection in inches due to Total load, including creep adjustment.

VERT(LL) = maximum Vertical panel point deflection in inches due to Live Load.

VERT(TL) = maximum Vertical panel point long term deflection in inches due to Total load, including creep adjustment.

W = Width of non-hanger bearing, in inches.

Refer to ASCE-7 for Wind and Seismic abbreviations.

Uppercase Acronyms not explained above are as defined in TPI 1.

References:

1. AWC: American Wood Council; 222 Catoclin Circle SE, Suite 201; Leesburg, VA 20175; www.awc.org.
2. ICC: International Code Council; www.iccsafe.org.
3. Alpine, a division of ITW Building Components Group Inc.: 155 Harlem Ave, North Building, 4th Floor, Glenview, IL 60025; www.alpineitw.com.
4. TPI: Truss Plate Institute, 2670 Crain Highway, Suite 203, Waldorf, MD 20601; www.tpinst.org.
5. SBCA: Wood Truss Council of America, 6300 Enterprise Lane, Madison, WI 53719; www.sbcacomponents.com.

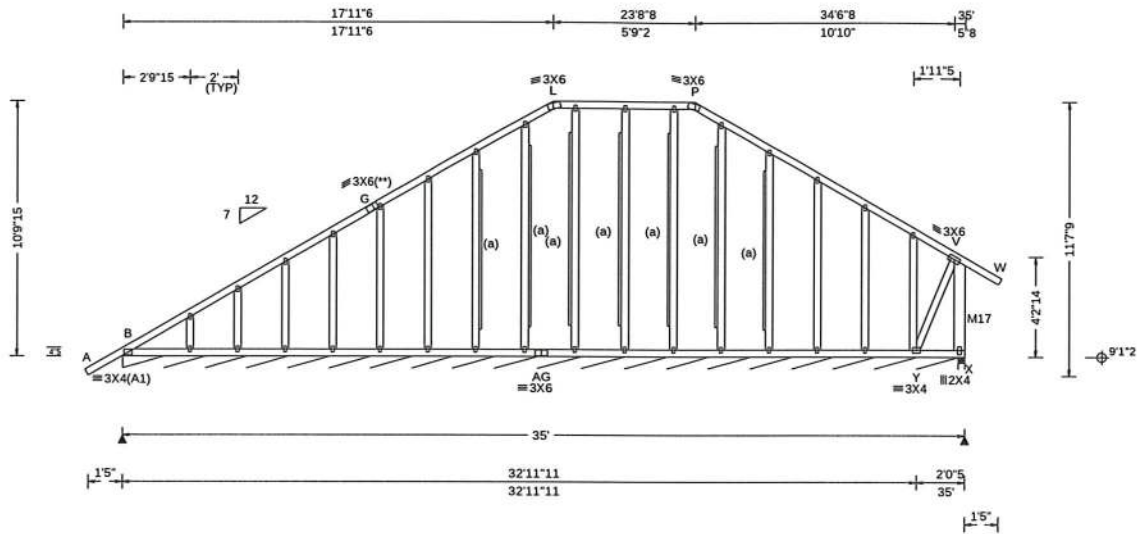

Loading Criteria (psf) TCLL: 20.00 TCDL: 7.00 BCLL: 0.00 BCDL: 10.00 Des Ld: 37.00 NCBCLL: 10.00 Soffit: 0.00 Load Duration: 1.25 Spacing: 24.0"	Wind Criteria Wind Std: ASCE 7-16 Speed: 130 mph Enclosure: Closed Risk Category: II EXP: B Kzt: NA Mean Height: 15.00 ft TCDL: 4.2 psf Soffit: 0.00 MWFRS Parallel Dist: h/2 to h C&C Dist a: 3.50 ft Loc. from endwall: not in 5.00 ft GCpi: 0.18 Wind Duration: 1.60	Snow Criteria (Pg,Pf in PSF) Pg: NA Ct: NA CAT: NA Pf: NA Ce: NA Lu: NA Cs: NA Snow Duration: NA Building Code: FBC 7th Ed. 2020 Res. TPI Std: 2014 Rep Fac: No FT/RT:20(0)/10(0) Plate Type(s): WAVE	Defl/CSI Criteria PP Deflection in loc L/defl L/# VERT(LL): 0.003 P 999 360 VERT(CL): 0.007 P 999 240 HORZ(LL): 0.004 T - - HORZ(TL): 0.005 T - - Creep Factor: 2.0 Max TC CSI: 0.207 Max BC CSI: 0.036 Max Web CSI: 0.125 VIEW Ver: 21.01.03A.0805.15	▲ Maximum Reactions (lbs), or *=PLF Gravity Non-Gravity Loc R+ /R- /Rh /Rw /U /RL B* 106 /- /- /39 /10 /7 X 306 /- /- /176 /18 /- Wind reactions based on MWFRS B Brg Wid = 416 Min Req = - X Brg Wid = 3.5 Min Req = 1.5 Bearings B & X are a rigid surface. Members not listed have forces less than 375#
--	---	---	---	---

Lumber
Top chord: 2x4 SP #1;
Bot chord: 2x4 SP #1;
Webs: 2x4 SP #3; M17 2x6 SP #1;

Bracing
(a) 1x4 #3SRB SPF-S or better "L" reinforcement.
80% length of web member. Attach with 8d Box or Gun (0.113"x2.5",min.)nails @ 6" oc.

Plating Notes
All plates are 1.5X3 except as noted.
(**) 1 plate(s) require special positioning. Refer to scaled plate plot details for special positioning requirements.

Loading
Truss designed to support 1-0-0 top chord outlookers and cladding load not to exceed 5.00 PSF one face and 24.0" span opposite face. Top chord must not be cut or notched, unless specified otherwise.

Wind
Wind loads based on MWFRS with additional C&C member design.
Right end vertical not exposed to wind pressure.
Wind loading based on both gable and hip roof types.

Additional Notes
See DWGS A14015ENC160118 & GBLLETIN0118 for gable wind bracing and other requirements.



COA #0 278
Florida Certificate of Product Approval #FL1999
05/02/2022

****WARNING** READ AND FOLLOW ALL NOTES ON THIS DRAWING!**
****IMPORTANT** FURNISH THIS DRAWING TO ALL CONTRACTORS INCLUDING THE INSTALLERS**
Trusses require extreme care in fabricating, handling, shipping, installing and bracing. Refer to and follow the latest edition of BCSI (Building Component Safety Information, by TPI and SBCA) for safety practices prior to performing these functions. Installers shall provide temporary bracing per BCSI. Unless noted otherwise, top chord shall have properly attached structural sheathing and bottom chord shall have a properly attached rigid ceiling. Locations shown for permanent lateral restraint of webs shall have bracing installed per BCSI sections B3, B7, or B10, as applicable. Apply plates to each face of truss and position as shown above and on the Joint Details, unless noted otherwise. Refer to drawings 160A-Z for standard plate positions. Refer to job's General Notes page for additional information.
Alpine, a division of ITW Building Components Group Inc. shall not be responsible for any deviation from this drawing, any failure to build the truss in conformance with ANSI/TPI 1, or for handling, shipping, installation and bracing of trusses. A seal on this drawing or cover page listing this drawing, indicates acceptance of professional engineering responsibility solely for the design shown. The suitability and use of this drawing for any structure is the responsibility of the Building Designer per ANSI/TPI 1 Sec.2.
For more information see these web sites: Alpine: alpineitw.com; TPI: tpinst.org; SBCA: sbcacomponents.com; ICC: iccsafe.org; AWC: awc.org



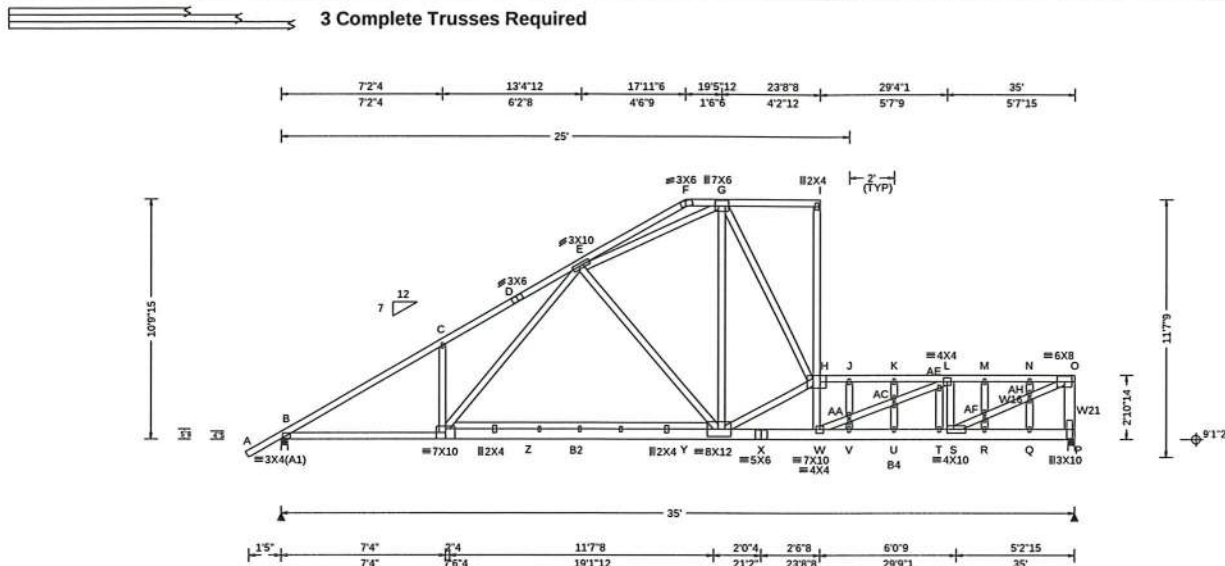

Loading Criteria (psf)	Wind Criteria
TCLL: 20.00	Wind Std: ASCE 7-16
TCDL: 7.00	Speed: 130 mph
BCLL: 0.00	Enclosure: Closed
BCDL: 10.00	Risk Category: II
Des Ld: 37.00	EXP: B Kzt: NA
NCBCLL: 0.00	Mean Height: 15.00 ft
Soffit: 0.00	TCDL: 4.2 psf
Load Duration: 1.25	BCDL: 5.2 psf
Spacing: 24.0 "	MWFRS Parallel Dist: 0 to h/2
	C&C Dist a: 3.50 ft
	Loc. from endwall: not in 9.00 ft
	GCpi: 0.18
	Wind Duration: 1.60

Snow Criteria (Pg, Pf in PSF)
Pg: NA Ct: NA CAT: NA
Pf: NA Ce: NA
Lu: NA Cs: NA
Snow Duration: NA
Building Code:
FBC 7th Ed. 2020 Res.
TPI Std: 2014
Rep Fac: No
FT/RT:20(0)/10(0)
Plate Type(s):
WAVE

Defl/CSI Criteria
PP Deflection in loc L/defl L/#
VERT(LL): 0.221 J 999 360
VERT(CL): 0.402 J 999 240
HORZ(LL): 0.084 F - -
HORZ(TL): 0.153 F - -
Creep Factor: 2.0
Max TC CSI: 0.259
Max BC CSI: 0.509
Max Web CSI: 0.874
VIEW Ver: 21.01.03A.0805.15

▲ Maximum Reactions (lbs)							
Gravity			Non-Gravity				
Loc	R+	/R-	/Rh	/Rw	/U	/RL	
B	2238	-	-	-	/258	-	
P	4606	-	-	-	/121	-	
Wind reactions based on MWFRS							
B	Brg Wid = 3.5		Min Req = 1.5				
P	Brg Wid = 3.5		Min Req = 1.8				
Bearings B & P are a rigid surface.							
Members not listed have forces less than 375#							
Maximum Top Chord Forces Per Ply (lbs)							
Chords		Tens.Comp.		Chords		Tens. Comp.	
B - C	159	-1315	K - L	180	-3163		
C - D	154	-1298	L - M	84	-2411		
D - E	146	-1265	M - N	84	-2411		
H - J	180	-3167	N - O	84	-2411		
J - K	180	-3163					

Lumber
 Top chord: 2x4 SP #1;
 Bot chord: 2x4 SP #1; B2, B4 2x6 SP #1;
 Webs: 2x4 SP #3; W16 2x4 SP #1; W21 2x6 SP #1;

It is the responsibility of the Building Designer and Truss Fabricator to review this drawing prior to cutting lumber to verify that all data, including dimensions and loads, conform to the architectural plans/specifications and fabricators truss layout.

Nailnote
 Nail Schedule: 0.128"x3", min. nails
 Top Chord: 1 Row @ 9.50" o.c.
 Bot Chord: 1 Row @ 12.00" o.c.
 Webs : 1 Row @ 4" o.c.
 Repeat nailing as each layer is applied. Use equal spacing between rows and stagger nails in each row to avoid splitting.

Special Loads

----- (Lumber Dur. Fac. = 1.25 / Plate Dur. Fac. = 1.25)

TC:	From 56 plf at -1.56 to 56 plf at 23.71
TC:	From 2 plf at 23.71 to 2 plf at 35.00
BC:	From 20 plf at 0.00 to 20 plf at 7.33
BC:	From 60 plf at 7.33 to 60 plf at 19.33
BC:	From 20 plf at 19.33 to 20 plf at 35.00
TC:	704 lb Conc. Load at 24.94, 26.94, 28.94, 30.94, 32.94, 34.94

Plating Notes
 All plates are 1.5X3 except as noted.

Wind
 Wind loads and reactions based on MWFRS.
 Right end vertical not exposed to wind pressure.
 Wind loading based on both gable and hip roof types.



COA #0 278
 Florida Certificate of Product Approval #FL1999
 05/02/2022

****WARNING**** READ AND FOLLOW ALL NOTES ON THIS DRAWING!
****IMPORTANT**** FURNISH THIS DRAWING TO ALL CONTRACTORS INCLUDING THE INSTALLERS
 Trusses require extreme care in fabricating, handling, shipping, installing and bracing. Refer to and follow the latest edition of BCSI (Building Component Safety Information, by TPI and SBCA) for safety practices prior to performing these functions. Installers shall provide temporary bracing per BCSI. Unless noted otherwise, top chord shall have properly attached structural sheathing and bottom chord shall have a properly attached rigid ceiling. Locations shown for permanent lateral restraint of webs shall have bracing installed per BCSI sections B3, B7, or B10, as applicable. Apply plates to each face of truss and position as shown above and on the Joint Details, unless noted otherwise. Refer to drawings 160A-Z for standard plate positions. Refer to job's General Notes page for additional information.
 Alpine, a division of ITW Building Components Group Inc. shall not be responsible for any deviation from this drawing, any failure to build the truss in conformance with ANSI/TPI 1, or for handling, shipping, installation and bracing of trusses. A seal on this drawing or cover page listing this drawing, indicates acceptance of professional engineering responsibility solely for the design shown. The suitability and use of this drawing for any structure is the responsibility of the Building Designer per ANSI/TPI 1 Sec.2.
 For more information see these web sites: Alpine: alpineitw.com; TPI: tpinst.org; SBCA: sbccomponents.com; ICC: iccsafe.org; AWC: awc.org



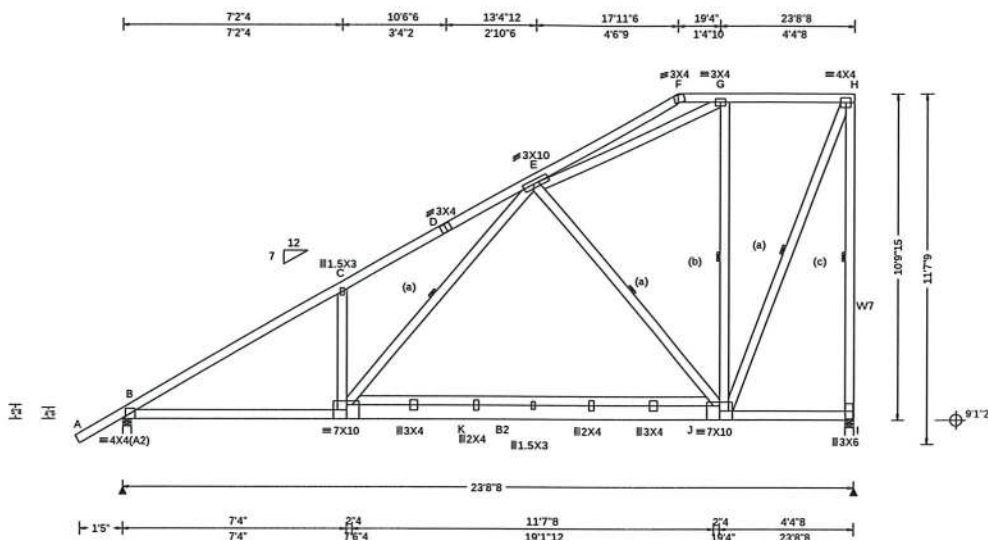

Loading Criteria (psf)	Wind Criteria	Snow Criteria (Pg, Pf in PSF)	Defl/CSI Criteria	▲ Maximum Reactions (lbs)
TCLL: 20.00 TCDL: 7.00 BCLL: 0.00 BCDL: 10.00 Des Ld: 37.00 NCBCLL: 10.00 Soffit: 0.00 Load Duration: 1.25 Spacing: 24.0 "	Wind Std: ASCE 7-16 Speed: 130 mph Enclosure: Closed Risk Category: II EXP: B Kzt: NA Mean Height: 15.00 ft TCDL: 4.2 psf BCDL: 5.2 psf MWFRS Parallel Dist: 0 to h/2 C&C Dist a: 3.00 ft Loc. from endwall: Any GCpi: 0.18 Wind Duration: 1.60	Pg: NA Ct: NA CAT: NA Pf: NA Ce: NA Lu: NA Cs: NA Snow Duration: NA Building Code: FBC 7th Ed. 2020 Res. TPI Std: 2014 Rep Fac: No FT/RT:20(0)/10(0) Plate Type(s): WAVE	PP Deflection in loc L/defl L/# VERT(LL): 0.162 K 999 360 VERT(CL): 0.252 K 999 240 HORZ(LL): 0.030 C - - HORZ(TL): 0.046 C - - Creep Factor: 2.0 Max TC CSI: 0.353 Max BC CSI: 0.443 Max Web CSI: 0.992 VIEW Ver: 21.01.03A.0805.15	Gravity Loc R+ /R- /Rh /Rw /U /RL B 1213 /- /- /571 /631 /268 I 1251 /- /- /498 /634 /- Non-Gravity Wind reactions based on MWFRS B Brg Wid = 3.5 Min Req = 1.5 I Brg Wid = 3.5 Min Req = 1.5 Bearings B & I are a rigid surface. Members not listed have forces less than 375# Maximum Top Chord Forces Per Ply (lbs) Chords Tens.Comp. Chords Tens. Comp. B - C 1053 -1883 D - E 954 -1744 C - D 1020 -1841 G - H 262 -471

Lumber
Top chord: 2x4 SP #1;
Bot chord: 2x4 SP #1; B2 2x6 SP #1;
Webs: 2x4 SP #3; W7 2x4 SP #1;

Bracing
(a) Continuous lateral restraint equally spaced on member. Or 1x4 #3SRB SPF-S or better "T" reinforcement. 80% length of web member. Attached with 8d Box or Gun (0.113"x2.5",min.)nails @ 6" oc.
(b) Continuous lateral restraint equally spaced on member. Or 2x4 #3 or better "T" reinforcement. 80% length of web member. Attached with 10d Box or Gun (0.128"x3",min.)nails @ 6" oc.
(c) Continuous lateral restraint equally spaced on member. Or 2x6 #3 or better "T" reinforcement. 80% length of web member. Attached with 10d Box or Gun (0.128"x3",min.)nails @ 6" oc.

Special Loads
----- (Lumber Dur.Fac.=1.25 / Plate Dur.Fac.=1.25)

TC: From	56 plf at	-1.56 to	56 plf at	23.71
BC: From	20 plf at	0.00 to	20 plf at	7.33
BC: From	60 plf at	7.33 to	60 plf at	19.33
BC: From	20 plf at	19.33 to	20 plf at	23.71
PLB: From	40 plf at	21.08 to	40 plf at	23.42

Wind
Wind loads based on MWFRS with additional C&C member design.
Right end vertical not exposed to wind pressure.
Wind loading based on both gable and hip roof types.

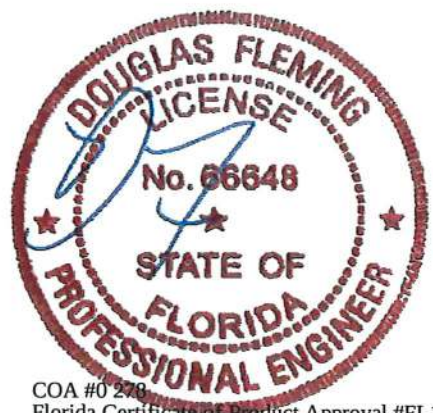

COA #0 278
Florida Certificate of Product Approval #FL1999
05/02/2022

****WARNING** READ AND FOLLOW ALL NOTES ON THIS DRAWING!**
****IMPORTANT** FURNISH THIS DRAWING TO ALL CONTRACTORS INCLUDING THE INSTALLERS**
Trusses require extreme care in fabricating, handling, shipping, installing and bracing. Refer to and follow the latest edition of BCSI (Building Component Safety Information, by TPI and SBICA) for safety practices prior to performing these functions. Installers shall provide temporary bracing per BCSI. Unless noted otherwise, top chord shall have properly attached structural sheathing and bottom chord shall have a properly attached rigid ceiling. Locations shown for permanent lateral restraint of webs shall have bracing installed per BCSI sections B3, B7, or B10, as applicable. Apply plates to each face of truss and position as shown above and on the Joint Details, unless noted otherwise. Refer to drawings 160A-Z for standard plate positions. Refer to job's General Notes page for additional information.
Alpine, a division of ITW Building Components Group Inc. shall not be responsible for any deviation from this drawing, any failure to build the truss in conformance with ANSI/TPI 1, or for handling, shipping, installation and bracing of trusses. A seal on this drawing or cover page listing this drawing, indicates acceptance of professional engineering responsibility solely for the design shown. The suitability and use of this drawing for any structure is the responsibility of the Building Designer per ANSI/TPI 1 Sec.2.
For more information see these web sites: Alpine: alpineitw.com; TPI: tpinst.org; SBICA: sbicacomponents.com; ICC: iccsafe.org; AWC: awc.org



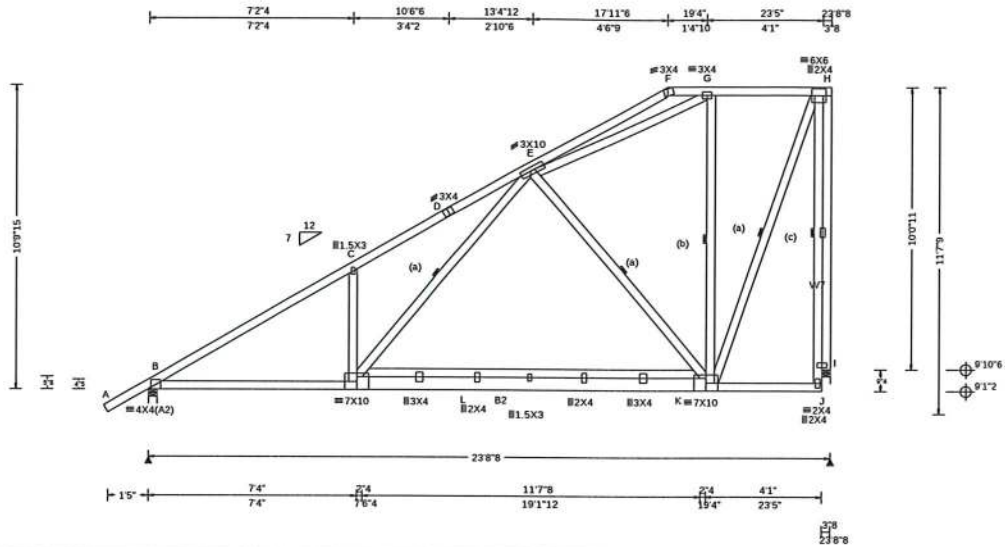

Loading Criteria (psf) TCLL: 20.00 TCDL: 7.00 BCLL: 0.00 BCDL: 10.00 Des Ld: 37.00 NCBCLL: 10.00 Soffit: 0.00 Load Duration: 1.25 Spacing: 24.0"	Wind Criteria Wind Std: ASCE 7-16 Speed: 130 mph Enclosure: Closed Risk Category: II EXP: B Kzt: NA Mean Height: 15.00 ft TCDL: 4.2 psf BCDL: 5.2 psf MWFRS Parallel Dist: h to 2h C&C Dist a: 3.00 ft Loc. from endwall: not in 9.00 ft GCpi: 0.18 Wind Duration: 1.60	Snow Criteria (Pg,Pf in PSF) Pg: NA Ct: NA CAT: NA Pf: NA Ce: NA Lu: NA Cs: NA Snow Duration: NA Building Code: FBC 7th Ed. 2020 Res. TPI Std: 2014 Rep Fac: No FT/RT:20(0)/10(0) Plate Type(s): WAVE	Defl/CSI Criteria PP Deflection in loc L/defl L/# VERT(LL): 0.160 L 999 360 VERT(CL): 0.249 L 999 240 HORZ(LL): 0.029 C - - HORZ(TL): 0.045 C - - Creep Factor: 2.0 Max TC CSI: 0.351 Max BC CSI: 0.442 Max Web CSI: 0.979 VIEW Ver: 21.01.03A.0805.15	▲ Maximum Reactions (lbs) Gravity Non-Gravity Loc R+ /R- /Rh /Rw /U /RL B 1203 /- /- /567 /626 /194 I 1247 /- /- /496 /642 /- Wind reactions based on MWFRS B Brg Wid = 3.5 Min Req = 1.5 I Brg Wid = 3.5 Min Req = 1.5 Bearings B & I are a rigid surface. Members not listed have forces less than 375# Maximum Top Chord Forces Per Ply (lbs) Chords Tens.Comp. Chords Tens. Comp. B - C 1042 -1864 D - E 944 -1725 C - D 1010 -1821 G - H 254 -453
--	---	---	---	---

Lumber
Top chord: 2x4 SP #1;
Bot chord: 2x4 SP #1; B2 2x6 SP #1;
Webs: 2x4 SP #3; W7 2x4 SP #1;
Rt Bearing Leg: 2x4 SP #1;

Bracing
(c) Continuous lateral restraint equally spaced on member.
(a) Continuous lateral restraint equally spaced on member. Or 1x4 #3SRB SPF-S or better "T" reinforcement. 80% length of web member. Attached with 8d Box or Gun (0.113"x2.5",min.)nails @ 6" oc.
(b) Continuous lateral restraint equally spaced on member. Or 2x4 #3 or better "T" reinforcement. 80% length of web member. Attached with 10d Box or Gun (0.128"x3",min.)nails @ 6" oc.

Special Loads
----- (Lumber Dur.Fac.=1.25 / Plate Dur.Fac.=1.25)
TC: From 56 plf at -1.56 to 56 plf at 23.71
BC: From 20 plf at 0.00 to 20 plf at 7.33
BC: From 60 plf at 7.33 to 60 plf at 19.33
BC: From 20 plf at 19.33 to 20 plf at 23.42
PLB: From 40 plf at 20.97 to 40 plf at 23.13

Wind
Wind loads based on MWFRS with additional C&C member design.
Right end vertical not exposed to wind pressure.
Wind loading based on both gable and hip roof types.



****WARNING**** READ AND FOLLOW ALL NOTES ON THIS DRAWING!
****IMPORTANT**** FURNISH THIS DRAWING TO ALL CONTRACTORS INCLUDING THE INSTALLERS
Trusses require extreme care in fabricating, handling, shipping, installing and bracing. Refer to and follow the latest edition of BCSI (Building Component Safety Information, by TPI and SBCE) for safety practices prior to performing these functions. Installers shall provide temporary bracing per BCSI. Unless noted otherwise, top chord shall have properly attached structural sheathing and bottom chord shall have a properly attached rigid ceiling. Locations shown for permanent lateral restraint of webs shall have bracing installed per BCSI sections B3, B7, or B10, as applicable. Apply plates to each face of truss and position as shown above and on the Joint Details, unless noted otherwise. Refer to drawings 160A-Z for standard plate positions. Refer to job's General Notes page for additional information.
Alpine, a division of ITW Building Components Group Inc. shall not be responsible for any deviation from this drawing, any failure to build the truss in conformance with ANSI/TPI 1, or for handling, shipping, installation and bracing of trusses. A seal on this drawing or cover page listing this drawing, indicates acceptance of professional engineering responsibility solely for the design shown. The suitability and use of this drawing for any structure is the responsibility of the Building Designer per ANSI/TPI 1 Sec.2.
For more information see these web sites: Alpine: alpineitw.com; TPI: tpinst.org; SBCE: sbccomponents.com; ICC: iccsafe.org; AWC: awc.org



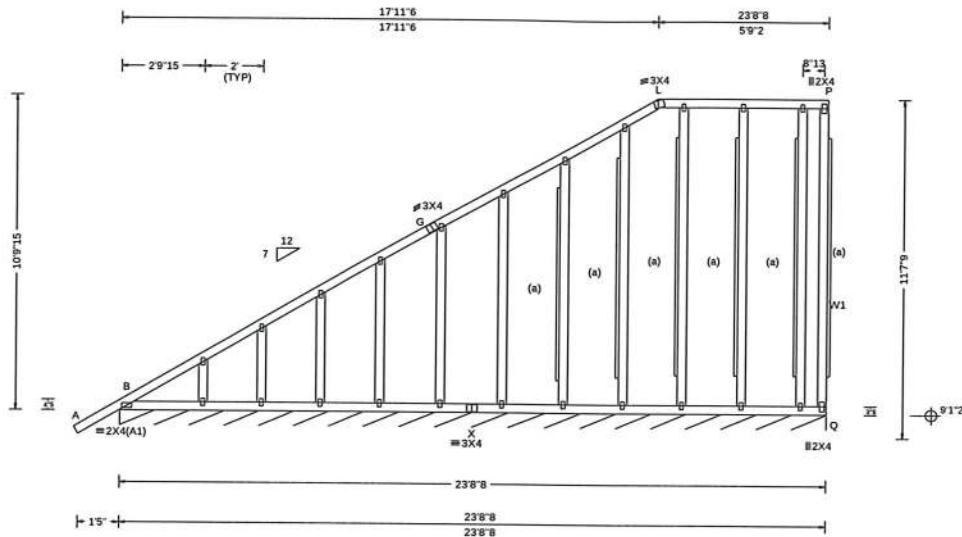

Loading Criteria (psf)	Wind Criteria	Snow Criteria (Pg,Pf in PSF)	Defl/CSI Criteria	▲ Maximum Reactions (lbs), or *-PLF
TCLL: 20.00 TCDL: 7.00 BCLL: 0.00 BCDL: 10.00 Des Ld: 37.00 NCBCLL: 10.00 Soffit: 0.00 Load Duration: 1.25 Spacing: 24.0"	Wind Std: ASCE 7-16 Speed: 130 mph Enclosure: Closed Risk Category: II EXP: B Kzt: NA Mean Height: 15.00 ft TCDL: 4.2 psf BCDL: 5.2 psf MWFRS Parallel Dist: 0 to h/2 C&C Dist a: 3.00 ft Loc. from endwall: Any GCpi: 0.18 Wind Duration: 1.60	Pg: NA Ct: NA CAT: NA Pf: NA Ce: NA Lu: NA Cs: NA Snow Duration: NA Building Code: FBC 7th Ed. 2020 Res. TPI Std: 2014 Rep Fac: No FT/RT:20(0)/10(0) Plate Type(s): WAVE	PP Deflection in loc L/defl L/# VERT(LL): 0.004 L 999 360 VERT(CL): 0.008 L 999 240 HORZ(LL): -0.007 L - - HORZ(TL): 0.009 L - - Creep Factor: 2.0 Max TC CSI: 0.125 Max BC CSI: 0.054 Max Web CSI: 0.125 VIEW Ver: 21.01.03A.0805.15	Gravity Loc R+ / R- / Rh / Rw / U / RL Q* 112 /- /- /48 /7 /13 Non-Gravity Wind reactions based on MWFRS Q Brg Wid = 284 Min Req = - Bearing B is a rigid surface. Members not listed have forces less than 375# Maximum Top Chord Forces Per Ply (lbs) Chords Tens.Comp. B - G 109 -376 Maximum Bot Chord Forces Per Ply (lbs) Chords Tens.Comp. B - X 408 -126

Lumber
Top chord: 2x4 SP #1;
Bot chord: 2x4 SP #1;
Webs: 2x4 SP #3; W1 2x4 SP #1;

Bracing
(a) 1x4 #3SRB SPF-S or better "L" reinforcement.
80% length of web member. Attach with 8d Box or Gun (0.113"x2.5",min.)nails @ 6" oc.

Plating Notes
All plates are 1.5X3 except as noted.

Loading
Truss designed to support 1-0-0 top chord outlookers and cladding load not to exceed 5.00 PSF one face and 24.0" span opposite face. Top chord must not be cut or notched, unless specified otherwise.

Wind
Wind loads based on MWFRS with additional C&C member design.
Right end vertical not exposed to wind pressure.
Wind loading based on both gable and hip roof types.

Additional Notes
See DWGS A14015ENC160118 & GBLLETIN0118 for gable wind bracing and other requirements.



COA #0 278
Florida Certificate of Product Approval #FL1999
05/02/2022

****WARNING**** READ AND FOLLOW ALL NOTES ON THIS DRAWING!
****IMPORTANT**** FURNISH THIS DRAWING TO ALL CONTRACTORS INCLUDING THE INSTALLERS
Trusses require extreme care in fabricating, handling, shipping, installing and bracing. Refer to and follow the latest edition of BCSI (Building Component Safety Information, by TPI and SBCE) for safety practices prior to performing these functions. Installers shall provide temporary bracing per BCSI. Unless noted otherwise, top chord shall have properly attached structural sheathing and bottom chord shall have a properly attached rigid ceiling. Locations shown for permanent lateral restraint of webs shall have bracing installed per BCSI sections B3, B7 or B10, as applicable. Apply plates to each face of truss and position as shown above and on the Joint Details, unless noted otherwise. Refer to drawings 160A-Z for standard plate positions. Refer to job's General Notes page for additional information.
Alpine, a division of ITW Building Components Group Inc, shall not be responsible for any deviation from this drawing, any failure to build the truss in conformance with ANSI/TPI 1, or for handling, shipping, installation and bracing of trusses. A seal on this drawing or cover page listing this drawing, indicates acceptance of professional engineering responsibility solely for the design shown. The suitability and use of this drawing for any structure is the responsibility of the Building Designer per ANSI/TPI 1 Sec.2.
For more information see these web sites: Alpine: alpineitw.com; TPI: tpinst.org; SBCE: sbcecomponents.com; ICC: iccsafe.org; AWC: awc.org



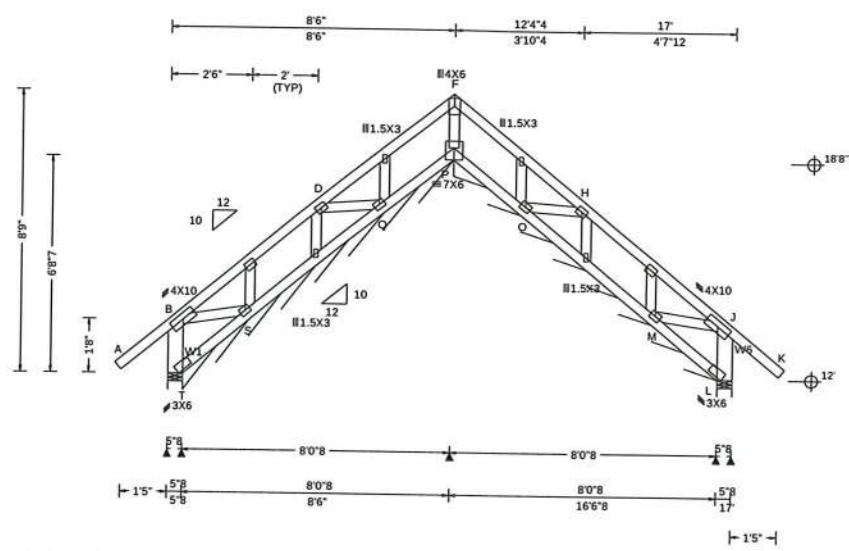

Loading Criteria (psf)	Wind Criteria	Snow Criteria (Pg, Pf in PSF)	Defl/CSI Criteria	▲ Maximum Reactions (lbs), or *=PLF
TCLL: 20.00 TCDL: 7.00 BCLL: 0.00 BCDL: 10.00 Des Ld: 37.00 NCBCLL: 10.00 Soffit: 0.00 Load Duration: 1.25 Spacing: 24.0"	Wind Std: ASCE 7-16 Speed: 130 mph Enclosure: Closed Risk Category: II EXP: B Kzt: NA Mean Height: 16.54 ft TCDL: 4.2 psf BCDL: 5.2 psf MWFRS Parallel Dist: 0 to h/2 C&C Dist a: 3.00 ft Loc. from endwall: Any GCpi: 0.18 Wind Duration: 1.60	Pg: NA Ct: NA CAT: NA Pf: NA Ce: NA Lu: NA Cs: NA Snow Duration: NA Building Code: FBC 7th Ed. 2020 Res. TPI Std: 2014 Rep Fac: No FT/RT:20(0)/10(0) Plate Type(s): WAVE	PP Deflection in loc L/defl L/# VERT(LL): 0.000 B 999 360 VERT(CL): 0.001 B 999 240 HORZ(LL): -0.002 L - - HORZ(TL): 0.004 L - - Creep Factor: 2.0 Max TC CSI: 0.156 Max BC CSI: 0.044 Max Web CSI: 0.036 VIEW Ver: 21.01.03A.0805.15	Gravity Loc R+ / R- / Rh / Rw / U / RL Non-Gravity T 257 /- /- /276 /120 /222 T* 82 /- /- /88 /26 /- P* 63 /- /- /51 /20 /- L 257 /- /- /211 /71 /- Wind reactions based on MWFRS T Brg Wid = 5.5 Min Req = 1.5 T Brg Wid = 96.5 Min Req = - P Brg Wid = 96.5 Min Req = - L Brg Wid = 5.5 Min Req = 1.5 Bearings T, T, P, & L are a rigid surface. Members not listed have forces less than 375#

Lumber
Top chord: 2x4 SP #1;
Bot chord: 2x4 SP #1;
Webs: 2x4 SP #3; W1, W6 2x6 SP #1;

Plating Notes
All plates are 3X4 except as noted.

Loading
Truss designed to support 1-0-0 top chord outlookers and cladding load not to exceed 5.00 PSF one face and 24.0" span opposite face. Top chord must not be cut or notched, unless specified otherwise.

Wind
Wind loads based on MWFRS with additional C&C member design.
End verticals not exposed to wind pressure.
Wind loading based on both gable and hip roof types.

Additional Notes
See DWGS A14030ENC160118 & GBLLETIN0118 for gable wind bracing and other requirements.
Shim all supports to solid bearing.

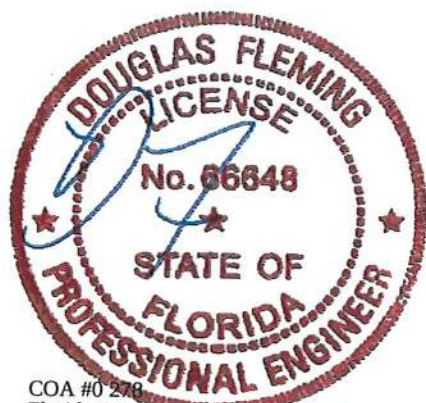

COA #0 278
Florida Certificate of Product Approval #FL1999
05/02/2022

****WARNING** READ AND FOLLOW ALL NOTES ON THIS DRAWING!**
****IMPORTANT** FURNISH THIS DRAWING TO ALL CONTRACTORS INCLUDING THE INSTALLERS**
Trusses require extreme care in fabricating, handling, shipping, installing and bracing. Refer to and follow the latest edition of BCSI (Building Component Safety Information, by TPI and SBCA) for safety practices prior to performing these functions. Installers shall provide temporary bracing per BCSI. Unless noted otherwise, top chord shall have properly attached structural sheathing and bottom chord shall have a properly attached rigid ceiling. Locations shown for permanent lateral restraint of webs shall have bracing installed per BCSI sections B3, B7, or B10, as applicable. Apply plates to each face of truss and position as shown above and on the Joint Details, unless noted otherwise. Refer to drawings 160A-Z for standard plate positions. Refer to job's General Notes page for additional information.
Alpine, a division of ITW Building Components Group Inc. shall not be responsible for any deviation from this drawing, any failure to build the truss in conformance with ANSI/TPI 1, or for handling, shipping, installation and bracing of trusses. A seal on this drawing or cover page listing this drawing, indicates acceptance of professional engineering responsibility solely for the design shown. The suitability and use of this drawing for any structure is the responsibility of the Building Designer per ANSI/TPI 1 Sec.2.
For more information see these web sites: Alpine: alpineitw.com; TPI: tpinst.org; SBCA: sbccomponents.com; ICC: iccsafe.org; AWC: awc.org



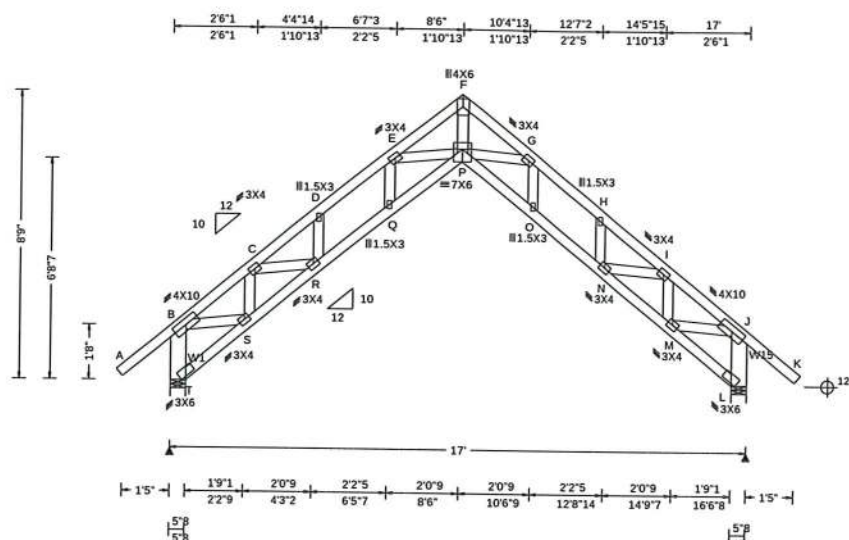

Loading Criteria (psf) TCLL: 20.00 TCDL: 7.00 BCLL: 0.00 BCDL: 10.00 Des Ld: 37.00 NCBCLL: 10.00 Soffit: 0.00 Load Duration: 1.25 Spacing: 24.0"	Wind Criteria Wind Std: ASCE 7-16 Speed: 130 mph Enclosure: Closed Risk Category: II EXP: B Kzt: NA Mean Height: 16.54 ft TCDL: 4.2 psf BCDL: 5.2 psf MWFRS Parallel Dist: 0 to h/2 C&C Dist a: 3.00 ft Loc. from endwall: Any GCpi: 0.18 Wind Duration: 1.60	Snow Criteria (Pg, Pf in PSF) Pg: NA Ct: NA CAT: NA Pf: NA Ce: NA Lu: NA Cs: NA Snow Duration: NA Building Code: FBC 7th Ed. 2020 Res. TPI Std: 2014 Rep Fac: No FT/RT: 20(0)/10(0) Plate Type(s): WAVE	Defl/CSI Criteria PP Deflection in loc L/defl L/# VERT(LL): 0.145 P 999 360 VERT(CL): 0.286 P 674 240 HORZ(LL): 0.262 L - - HORZ(TL): 0.516 L - - Creep Factor: 2.0 Max TC CSI: 0.300 Max BC CSI: 0.495 Max Web CSI: 0.893 VIEW Ver: 21.01.03A.0805.15	▲ Maximum Reactions (lbs) <table border="1"> <thead> <tr> <th rowspan="2">Loc</th> <th colspan="2">Gravity</th> <th colspan="2">Non-Gravity</th> </tr> <tr> <th>R+</th> <th>/R-</th> <th>/Rh</th> <th>/Rw / U / RL</th> </tr> </thead> <tbody> <tr> <td>T</td> <td>792</td> <td>-</td> <td>-</td> <td>/451 /30 /197</td> </tr> <tr> <td>L</td> <td>792</td> <td>-</td> <td>-</td> <td>/451 /30 /-</td> </tr> </tbody> </table> <p>Wind reactions based on MWFRS T Brg Wid = 5.5 Min Req = 1.5 L Brg Wid = 5.5 Min Req = 1.5 Bearings T & L are a rigid surface. Members not listed have forces less than 375#</p> Maximum Top Chord Forces Per Ply (lbs) <table border="1"> <thead> <tr> <th>Chords</th> <th>Tens.Comp.</th> <th>Chords</th> <th>Tens. Comp.</th> </tr> </thead> <tbody> <tr> <td>B - C</td> <td>85 -801</td> <td>F - G</td> <td>75 -2051</td> </tr> <tr> <td>C - D</td> <td>55 -1667</td> <td>G - H</td> <td>0 -1804</td> </tr> <tr> <td>D - E</td> <td>84 -1804</td> <td>H - I</td> <td>0 -1667</td> </tr> <tr> <td>E - F</td> <td>66 -2051</td> <td>I - J</td> <td>95 -801</td> </tr> </tbody> </table>	Loc	Gravity		Non-Gravity		R+	/R-	/Rh	/Rw / U / RL	T	792	-	-	/451 /30 /197	L	792	-	-	/451 /30 /-	Chords	Tens.Comp.	Chords	Tens. Comp.	B - C	85 -801	F - G	75 -2051	C - D	55 -1667	G - H	0 -1804	D - E	84 -1804	H - I	0 -1667	E - F	66 -2051	I - J	95 -801
Loc	Gravity		Non-Gravity																																								
	R+	/R-	/Rh	/Rw / U / RL																																							
T	792	-	-	/451 /30 /197																																							
L	792	-	-	/451 /30 /-																																							
Chords	Tens.Comp.	Chords	Tens. Comp.																																								
B - C	85 -801	F - G	75 -2051																																								
C - D	55 -1667	G - H	0 -1804																																								
D - E	84 -1804	H - I	0 -1667																																								
E - F	66 -2051	I - J	95 -801																																								

Lumber
 Top chord: 2x4 SP #1;
 Bot chord: 2x4 SP #1;
 Webs: 2x4 SP #3; W1, W15 2x6 SP #1;

Wind
 Wind loads based on MWFRS with additional C&C member design.
 End verticals not exposed to wind pressure.
 Wind loading based on both gable and hip roof types.

Additional Notes
 Shim all supports to solid bearing.

Maximum Bot Chord Forces Per Ply (lbs)

Chords	Tens.Comp.	Chords	Tens. Comp.
S - R	855 -251	P - O	1738 0
R - Q	1616 -228	O - N	1616 0
Q - P	1738 -218	N - M	847 0

Maximum Web Forces Per Ply (lbs)

Webs	Tens.Comp.	Webs	Tens. Comp.
B - T	187 -615	P - G	457 -199
B - S	772 -19	N - I	697 0
S - C	27 -630	I - M	4 -630
C - R	697 0	M - J	772 -33
E - P	423 0	L - J	178 -615
F - P	2344 -84		



COA #0 278
 Florida Certificate of Product Approval #FL1999
 05/02/2022

****WARNING**** READ AND FOLLOW ALL NOTES ON THIS DRAWING!
****IMPORTANT**** FURNISH THIS DRAWING TO ALL CONTRACTORS INCLUDING THE INSTALLERS
 Trusses require extreme care in fabricating, handling, shipping, installing and bracing. Refer to and follow the latest edition of BCSI (Building Component Safety Information, by TPI and SBCA) for safety practices prior to performing these functions. Installers shall provide temporary bracing per BCSI. Unless noted otherwise, top chord shall have properly attached structural sheathing and bottom chord shall have a properly attached rigid ceiling. Locations shown for permanent lateral restraint of webs shall have bracing installed per BCSI sections B3, B7 or B10, as applicable. Apply plates to each face of truss and position as shown above and on the Joint Details, unless noted otherwise. Refer to drawings 160A-Z for standard plate positions. Refer to job's General Notes page for additional information.
 Alpine, a division of ITW Building Components Group Inc, shall not be responsible for any deviation from this drawing, any failure to build the truss in conformance with ANSI/TPI 1, or for handling, shipping, installation and bracing of trusses. A seal on this drawing or cover page listing this drawing, indicates acceptance of professional engineering responsibility solely for the design shown. The suitability and use of this drawing for any structure is the responsibility of the Building Designer per ANSI/TPI 1 Sec.2.
 For more information see these web sites: Alpine: alpineitw.com; TPI: tpinst.org; SBCA: sbcacomponents.com; ICC: iccsafe.org; AWC: awc.org



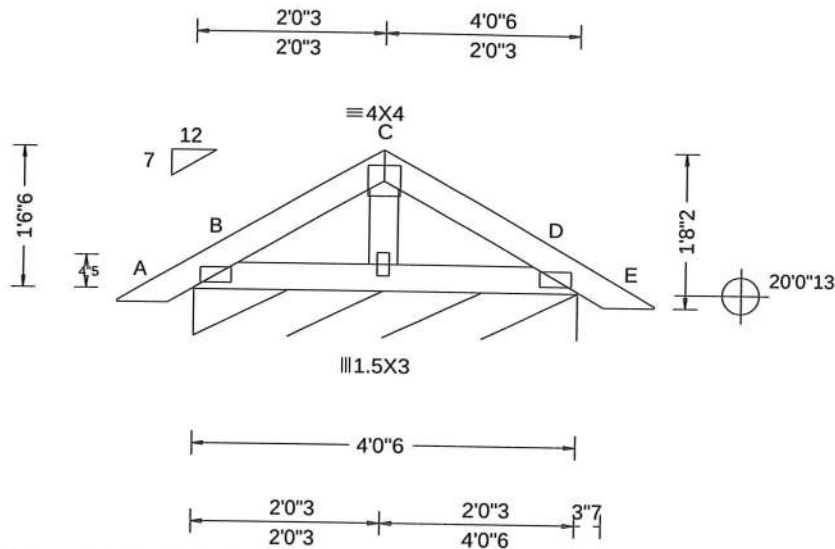

Loading Criteria (psf)	Wind Criteria	Snow Criteria (Pg,Pf in PSF)	Defl/CSI Criteria	▲ Maximum Reactions (lbs), or *=PLF
TCLL: 20.00 TCDL: 7.00 BCLL: 0.00 BCDL: 10.00 Des Ld: 37.00 NCBCLL: 10.00 Soffit: 0.00 Load Duration: 1.25 Spacing: 24.0 "	Wind Std: ASCE 7-16 Speed: 130 mph Enclosure: Closed Risk Category: II EXP: B Kzt: NA Mean Height: 20.77 ft TCDL: 4.2 psf BCDL: 5.2 psf MWFRS Parallel Dist: 0 to h/2 C&C Dist a: 3.00 ft Loc. from endwall: Any GCpi: 0.18 Wind Duration: 1.60	Pg: NA Ct: NA CAT: NA Pf: NA Ce: NA Lu: NA Cs: NA Snow Duration: NA Building Code: FBC 7th Ed. 2020 Res. TPI Std: 2014 Rep Fac: No FT/RT:20(0)/10(0) Plate Type(s): WAVE	PP Deflection in loc L/def L/# VERT(LL): 0.000 D 999 360 VERT(CL): 0.000 D 999 240 HORZ(LL): -0.000 D - - HORZ(TL): 0.000 D - - Creep Factor: 2.0 Max TC CSI: 0.032 Max BC CSI: 0.027 Max Web CSI: 0.010 VIEW Ver: 21.01.03A.0805.15	Gravity Non-Gravity Loc R+ / R- / Rh / Rw / U / RL B* 92 /- /- /43 /14 /9 Wind reactions based on MWFRS B Brg Wid = 48.4 Min Req = - Bearing B is a rigid surface. Members not listed have forces less than 375#

Lumber

Top chord: 2x4 SP #1;
Bot chord: 2x4 SP #1;
Webs: 2x4 SP #3;

Plating Notes

All plates are 2X4(A1) except as noted.

Wind

Wind loads based on MWFRS with additional C&C member design.
Wind loading based on both gable and hip roof types.

Additional Notes

See DWGS A14030ENC160118 & GBLLETIN0118 for gable wind bracing and other requirements.
Refer to drawing PB160160118 or piggyback detail.

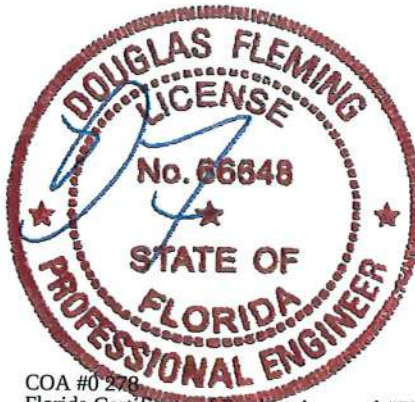

COA #0 278
Florida Certificate of Product Approval #FL1999
05/02/2022

****WARNING** READ AND FOLLOW ALL NOTES ON THIS DRAWING!**
****IMPORTANT** FURNISH THIS DRAWING TO ALL CONTRACTORS INCLUDING THE INSTALLERS**

Trusses require extreme care in fabricating, handling, shipping, installing and bracing. Refer to and follow the latest edition of BCSI (Building Component Safety Information, by TPI and SBCA) for safety practices prior to performing these functions. Installers shall provide temporary bracing per BCSI. Unless noted otherwise, top chord shall have properly attached structural sheathing and bottom chord shall have a properly attached rigid ceiling. Locations shown for permanent lateral restraint of webs shall have bracing installed per BCSI sections B3, B7, or B10, as applicable. Apply plates to each face of truss and position as shown above and on the Joint Details, unless noted otherwise. Refer to drawings 160A-Z for standard plate positions. Refer to job's General Notes page for additional information.

Alpine, a division of ITW Building Components Group Inc, shall not be responsible for any deviation from this drawing, any failure to build the truss in conformance with ANSI/TPI 1, or for handling, shipping, installation and bracing of trusses. A seal on this drawing or cover page listing this drawing, indicates acceptance of professional engineering responsibility solely for the design shown. The suitability and use of this drawing for any structure is the responsibility of the Building Designer per ANSI/TPI 1 Sec.2.

For more information see these web sites: Alpine: alpineitw.com; TPI: tpinst.org; SBCA: sbcacomponents.com; ICC: iccsafe.org; AWC: awc.org

Piggyback Detail - ASCE 7-16: 160 mph, 30' Mean Height, Enclosed, Exposure C, Kzt=1.00

160 mph Wind, 30,000 ft Mean Hgt, ASCE 7-16, Enclosed Bldg, located anywhere in roof, Exp C, Wind DL = 5.0 psf (gh), Kzt=1.0, Dr 140 mph wind, 30,000 ft Mean Hgt, ASCE 7-16, Enclosed Bldg, located anywhere in roof, Exp D, Wind DL = 5.0 psf (gh), Kzt=1.0.

Note: Top chords of trusses supporting piggyback cap trusses must be adequately braced by sheathing or purlins. The building Engineer of Record shall provide diagonal bracing or any other suitable anchorage to permanently restrain purlins, and lateral bracing for out of plane loads over gable ends. Medium truss spacing is 24' o.c. detail is not applicable if cap supports additional loads such as cupola, steeple, chimney or drag strut loads.

See Refer to Engineer's sealed truss design drawing for piggyback and base truss specifications.

Detail A : Purlin Spacing = 24" O.C. OR LESS

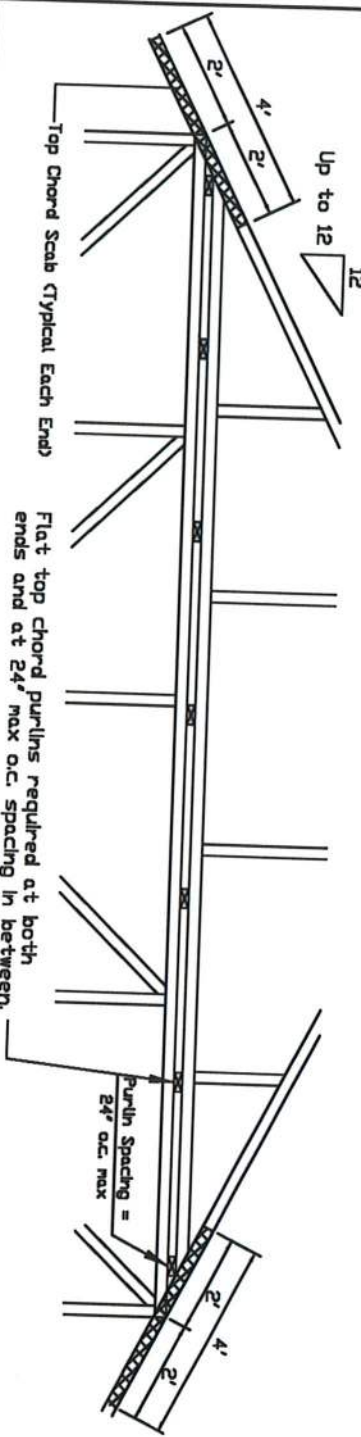

Piggyback cap truss slant nailed to all top chord purlin bracing with (2) 16d box nails (0.135"x3.5") and secure top chord with 2x4 #3 grade scab (1 side only at each end) attached with 2 rows of 10d box nails (0.128"x3") at 4' o.c.

Attach purlin bracing to the flat top chord using (2) 16d box nails (0.135"x3.5").

The top chord #3 grade 2x4 scab may be replaced with either of the following: (1) 3x8 Trulox plate attached with (8) 0.120"x1.375" nails, (4) into cap TC & (4) into base truss TC or (2) 2BPB wave piggyback plate attached to the piggyback truss TC and attached to the base truss TC with (4) 0.120"x1.375" nails. Note: Nailing thru holes of wave plate is acceptable.

Detail B : Purlin Spacing > 24" O.C.

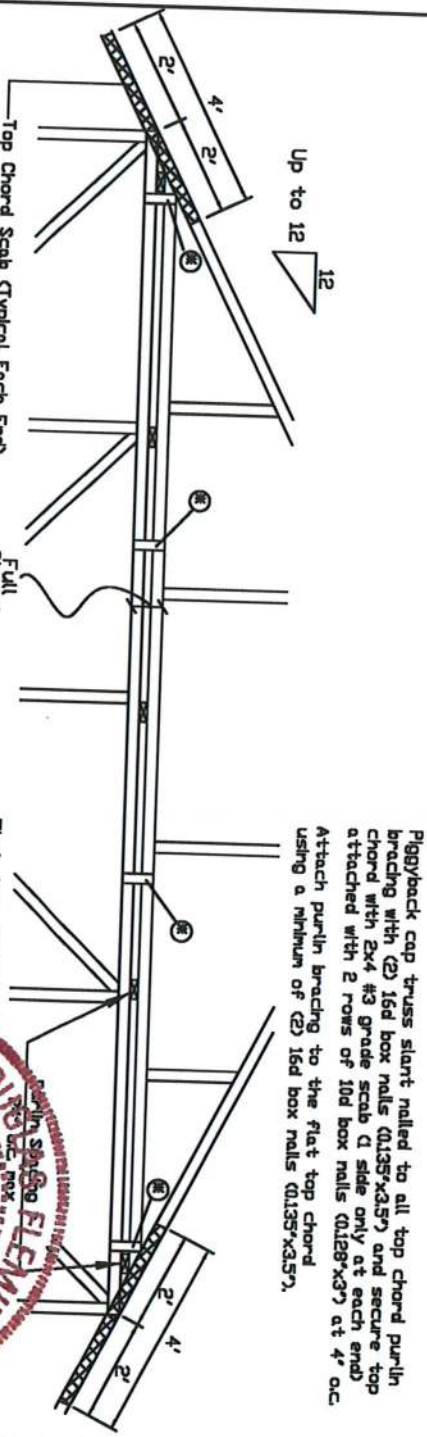

Piggyback cap truss slant nailed to all top chord purlin bracing with (2) 16d box nails (0.135"x3.5") and secure top chord with 2x4 #3 grade scab (1 side only at each end) attached with 2 rows of 10d box nails (0.128"x3") at 4' o.c.

Attach purlin bracing to the flat top chord using a minimum of (2) 16d box nails (0.135"x3.5").

APA Rated Gussset
8"x8"x7/16" (gh) APA rated sheathing gusssets (each face), Attach @ 8" o.c. (3) in cap bottom chord and (4) in base truss top chord. Gusssets may be staggered 4' o.c. front to back faces.

2x4 Vertical Scabs
2x4 SPF #2, full chord depth scabs (each face), Attach @ 8" o.c. with (6) 10d box nails (0.128"x3") per scab, (3) in cap bottom chord and (3) in base truss top chord. Scabs may be staggered 4' o.c. front to back faces.

2BPB Wave Piggyback Plate
One 2BPB wave piggyback plate to each face @ 8" o.c. Attach teeth to piggyback at time of installation. Attach teeth to supporting truss with (4) 0.120"x1.375" nails per face per ply. Piggyback plates may be staggered 4' o.c. front to back faces.

Note: If purlins or sheathing are not specified on the flat top of the truss, purlins must be installed at 24' o.c. max. and use Detail A.



155 Harlem Ave
North Building, 4th Floor
Glenview, IL 60025

Trusses require extreme care in fabricating, handling, shipping, installing and bracing. Refer to the latest edition of ASCE Guiding Principles for Truss Fabrication, by TPI and SCSA for specific instructions. Truss fabricators shall have bracing, attached rigid ceiling. Locations shown for structural sheathing and bracing shall be in accordance with ASCE 7-16, as applicable. Refer to drawings 1500-2 for standard plate positions.

Note: A division of ITW Building Components Group Inc. shall not be responsible for any deviations from the design and construction of trusses. A truss is a structure of trusses. The stability and load carrying capacity of a truss is dependent on the stability of the supporting structure. For more information see the Job's general notes page and those with whom ALPINE manufactures TPI www.alpine.com or www.alpine.com/technical/2D-visualizations



SPACING	24.0"
REF	PIGGYBACK
DATE	01/02/2018
DRWG	PB160160118