

W.B. Howland Truss Co.
 610 11th St. SW
 Live Oak, FL 32064
 (386) 362-1235
 (386) 362-7124 (Fax)
 howlandtruss@gmail.com

ROOF PITCH: 4/12, 6/12 -- FASCIA ALIGNED
 OVERHANG: 12" PLUMB CUT

CEILING: FLAT

EXT. WALLS: FRAME

LOADING: 40 PSF TL
 WIND LOAD: 130
 CATEGORY: II
 EXPOSURE: C
 DEFLECTION: 360/240

DATE: 8/13/21

JOB #: 22-6881

Job Name: Reserve at Jewel Lake 35
 Customer: Century Complete
 Designer: Chris McCall
 ADDRESS: 435 SW Jewel Lake Dr
 SALESMAN: Fill in later
 : <Not Found>

JOB NO:
 22-6881

PAGE NO:
 1 OF 1

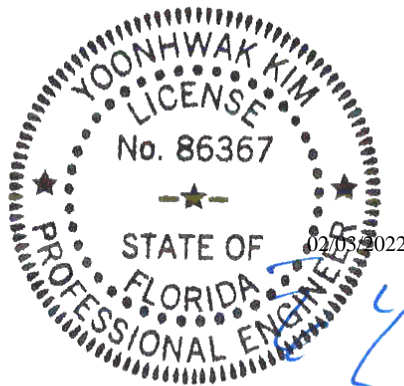

Alpine, an ITW Company
 6750 Forum Drive, Suite 305
 Orlando, FL 32821
 Phone: (800)755-6001
 www.alpineitw.com



This document has been electronically signed and sealed using a Digital Signature. Printed copies without an original signature must be verified using the original electronic version.

Site Information:	Page 1:
Customer: W. B. Howland Company, Inc.	Job Number: 22-6881
Job Description: Reserve at Jewel Lake 35 - Carlisle B1 - GL	
Address: 435 SW Jewel Lake Dr, FL	

Job Engineering Criteria:	
Design Code: FBC 7th Ed. 2020 Res.	IntelliVIEW Version: 21.01.01A JRef #: 1XcR2150022
Wind Standard: ASCE 7-16 Wind Speed (mph): 130	Design Loading (psf): 40.00
Building Type: Closed	

This package contains general notes pages, 24 truss drawing(s) and 3 detail(s).

Item	Drawing Number	Truss
1	034.22.1035.42226	A01
3	034.22.1035.42101	A03
5	034.22.1035.41976	A05
7	034.22.1035.42148	A07
9	034.22.1035.42993	A09
11	034.22.1035.43789	A11
13	034.22.1035.43118	A13
15	034.22.1035.44148	A15
17	034.22.1035.44101	B01
19	034.22.1035.42132	HJ01
21	034.22.1035.41305	J03
23	034.22.1035.43273	J05
25	A14015ENC160118	
27	GBLLETIN0118	

Item	Drawing Number	Truss
2	034.22.1035.42992	A02
4	034.22.1035.42789	A04
6	034.22.1035.42835	A06
8	034.22.1035.42320	A08
10	034.22.1035.43585	A10
12	034.22.1035.43773	A12
14	034.22.1035.43320	A14
16	034.22.1035.43117	A16
18	034.22.1035.43617	B02
20	034.22.1035.41320	J01
22	034.22.1035.41321	J04
24	034.22.1035.42335	J06
26	BRCLBSUB0119	

General Notes

Truss Design Engineer Scope of Work, Design Assumptions and Design Responsibilities:

The design responsibilities assumed in the preparation of these design drawings are those specified in ANSI/TPI 1, Chapter 2; and the National Design Standard for Metal Plate Connected Wood Truss Construction, by the Truss Plate Institute. The truss component designs conform to the applicable provisions of ANSI/TPI 1 and NDS, the National Design Specification for Wood Construction by AWC. The truss component designs are based on the specified loading and dimension information furnished by others to the Truss Design Engineer. The Truss Design Engineer has no duty to independently verify the accuracy or completeness of the information provided by others and may rely on that information without liability. The responsibility for verification of that information remains with others neither employed nor controlled by the Truss Design Engineer. The Truss Design Engineer's seal and signature on the attached drawings, or cover page listing these drawings, indicates acceptance of professional engineering responsibility solely for the truss component designs and not for the technical information furnished by others which technical information and consequences thereof remain their sole responsibility.

The suitability and use of these drawings for any particular structure is the responsibility of the Building Designer in accordance with ANSI/TPI 1 Chapter 2. The Building Designer is responsible for determining that the dimensions and loads for each truss component match those required by the plans and by the actual use of the individual component, and for ascertaining that the loads shown on the drawings meet or exceed applicable building code requirements and any additional factors required in the particular application. Truss components using metal connector plates with integral teeth shall not be placed in environments that will cause the moisture content of the wood in which plates are embedded to exceed 19% and/or cause corrosion of connector plates and other metal fasteners.

The Truss Design Engineer shall not be responsible for items beyond the specific scope of the agreed contracted work set forth herein, including but not limited to: verifying the dimensions of the truss component, calculation of any of the truss component design loads, inspection of the truss components before or after installation, the design of temporary or permanent bracing and their attachment required in the roof and/or floor systems, the design of diaphragms or shear walls, the design of load transfer connections to and from diaphragms and shear walls, the design of load transfer to the foundation, the design of connections for truss components to their bearing supports, the design of the bearing supports, installation of the truss components, observation of the truss component installation process, review of truss assembly procedures, sequencing of the truss component installation, construction means and methods, site and/or worker safety in the installation of the truss components and/or its connections.

This document may be a high quality facsimile of the original engineering document which is a digitally signed electronic file with third party authentication. A wet or embossed seal copy of this engineering document is available upon request.

Temporary Lateral Restraint and Bracing:

Temporary lateral restraint and diagonal bracing shall be installed according to the provisions of BCSI chapters B1, B2, B7 and/or B10 (Building Component Safety Information, by TPI and SBCA), or as specified by the Building Designer or other Registered Design Professional. The required locations for lateral restraint and/or bracing depicted on these drawings are only for the permanent lateral support of the truss members to reduce buckling lengths, and do not apply to and may not be relied upon for the temporary stability of the truss components during their installation.

Permanent Lateral Restraint and Bracing:

The required locations for lateral restraint or bracing depicted on these drawings are for the permanent lateral support of the truss members to reduce buckling lengths. Permanent lateral support shall be installed according to the provisions of BCSI chapters B3, B7 and/or B10, or as specified by the Building Designer or other Registered Design Professional. These drawings do not depict or specify installation/erection bracing, wind bracing, portal bracing or similar building stability bracing which are parts of the overall building design to be specified, designed and detailed by the Building Designer.

Connector Plate Information:

Alpine connector plates are made of ASTM A653 or ASTM A1063 galvanized steel with the following designations, gauges and grades: W=Wave, 20ga, grade 40; H=High Strength, 20ga, grade 60; S=Super Strength, 18ga, grade 60. Information on model code compliance is contained in the ICC Evaluation Service report ESR-1118, available on-line at www.icc-es.org.

Fire Retardant Treated Lumber:

Fire retardant treated lumber must be properly re-dried and maintained below 19% or less moisture level through all stages of construction and usage. Fire retardant treated lumber may be more brittle than untreated lumber. Special handling care must be taken to prevent breakage during all handling activities.

General Notes (continued)

Key to Terms:

Information provided on drawings reflects a summary of the pertinent information required for the truss design. Detailed information on load cases, reactions, member lengths, forces and members requiring permanent lateral support may be found in calculation sheets available upon written request.

BCDL = Bottom Chord standard design Dead Load in pounds per square foot.

BCLL = Bottom Chord standard design Live Load in pounds per square foot.

CL = Certified lumber.

Des Ld = total of TCLL, TCDL, BCLL and BCDL Design Load in pounds per square foot.

FRT = Fire Retardant Treated lumber.

FRT-DB = D-Blaze Fire Retardant Treated lumber.

FRT-DC = Dricon Fire Retardant Treated lumber.

FRT-FP = FirePRO Fire Retardant Treated lumber.

FRT-FL = FlamePRO Fire Retardant Treated lumber.

FRT-FT = FlameTech Fire Retardant Treated lumber.

FRT-PG = PYRO-GUARD Fire Retardant Treated lumber.

g = green lumber.

HORZ(LL) = maximum Horizontal panel point deflection due to Live Load, in inches.

HORZ(TL) = maximum Horizontal panel point long term deflection in inches, due to Total Load, including creep adjustment.

HPL = additional Horizontal Load added to a truss Piece in pounds per linear foot or pounds.

Ic = Incised lumber.

FJ = Finger Jointed lumber.

L/# = user specified divisor for limiting span/deflection ratio for evaluation of actual L/defl value.

L/defl = ratio of Length between bearings, in inches, divided by the vertical Deflection due to creep, in inches, at the referenced panel point. Reported as 999 if greater than or equal to 999.

Loc = Location, starting location of left end of bearing or panel point (joint) location of deflection.

Max BC CSI = Maximum bending and axial Combined Stress Index for Bottom Chords for of all load cases.

Max TC CSI = Maximum bending and axial Combined Stress Index for Top Chords for of all load cases.

Max Web CSI = Maximum bending and axial Combined Stress Index for Webs for of all load cases.

NCBCLL = Non-Concurrent Bottom Chord design Live Load in pounds per square foot.

PL = additional Load applied at a user specified angle on a truss Piece in pounds per linear foot or pounds.

PLB = additional vertical load added to a Bottom chord Piece of a truss in pounds per linear foot or pounds

PLT = additional vertical load added to a Top chord Piece of a truss in pounds per linear foot or pounds.

PP = Panel Point.

R = maximum downward design Reaction, in pounds, from all specified gravity load cases, at the indicated location (Loc).

-R = maximum upward design Reaction, in pounds, from all specified gravity load cases, at the identified location (Loc).

Rh = maximum horizontal design Reaction in either direction, in pounds, from all specified gravity load cases, at the indicated location (Loc).

RL = maximum horizontal design Reaction in either direction, in pounds, from all specified non-gravity (wind or seismic) load cases, at the indicated location (Loc).

Rw = maximum downward design Reaction, in pounds, from all specified non-gravity (wind or seismic) load cases, at the identified location (Loc).

TCDL = Top Chord standard design Dead Load in pounds per square foot.

TCLL = Top Chord standard design Live Load in pounds per square foot.

U = maximum Upward design reaction, in pounds, from all specified non-gravity (wind or seismic) load cases, at the indicated location (Loc).

VERT(CL) = maximum Vertical panel point deflection in inches due to Live Load and Creep Component of Dead Load in inches.

VERT(CTL) = maximum Vertical panel point deflection ratios due to Live Load and Creep Component of Dead Load, and maximum long term Vertical panel point deflection in inches due to Total load, including creep adjustment.

VERT(LL) = maximum Vertical panel point deflection in inches due to Live Load.

VERT(TL) = maximum Vertical panel point long term deflection in inches due to Total load, including creep adjustment.

W = Width of non-hanger bearing, in inches.

Refer to ASCE-7 for Wind and Seismic abbreviations.

Uppercase Acronyms not explained above are as defined in TPI 1.

References:

1. AWC: American Wood Council; 222 Catocin Circle SE, Suite 201; Leesburg, VA 20175; www.awc.org.
2. ICC: International Code Council; www.iccsafe.org.
3. Alpine, a division of ITW Building Components Group Inc.: 514 Earth City Expressway, Suite 242, Earth City, MO 63045; www.alpineitw.com.
4. TPI: Truss Plate Institute, 2670 Crain Highway, Suite 203, Waldorf, MD 20601; www.tpinst.org.
5. SBCA: Wood Truss Council of America, 6300 Enterprise Lane, Madison, WI 53719; www.sbcacomponents.com.

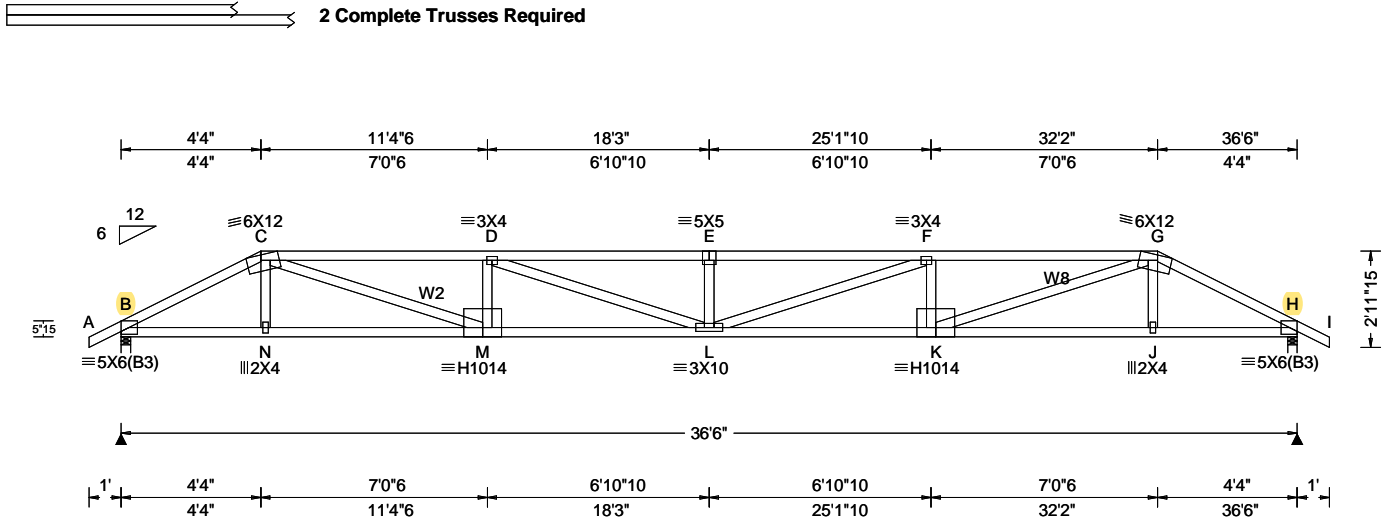

Loading Criteria (psf) TCLL: 20.00 TCDL: 10.00 BCLL: 0.00 BCDL: 10.00 Des Ld: 40.00 NCBCLL: 0.00 Soffit: 2.00 Load Duration: 1.25 Spacing: 24.0 "	Wind Criteria Wind Std: ASCE 7-16 Speed: 130 mph Enclosure: Closed Risk Category: II EXP: C Kzt: NA Mean Height: 15.00 ft TCDL: 5.0 psf BCDL: 5.0 psf MWFRS Parallel Dist: 0 to h/2 C&C Dist a: 3.65 ft Loc. from endwall: not in 4.50 ft GCp: 0.18 Wind Duration: 1.60	Snow Criteria (Pg,Pf in PSF) Pg: NA Ct: NA CAT: NA Pf: NA Ce: NA Lu: NA Cs: NA Snow Duration: NA Building Code: FBC 7th Ed. 2020 Res. TPI Std: 2014 Rep Fac: No FT/RT:20(0)/10(0) Plate Type(s): WAVE, HS	Defl/CSI Criteria PP Deflection in loc L/defl L/# VERT(LL): 0.636 E 684 360 VERT(CL): 1.277 E 340 240 HORZ(LL): 0.102 C - - HORZ(TL): 0.204 C - - Creep Factor: 2.0 Max TC CSI: 0.847 Max BC CSI: 0.736 Max Web CSI: 0.743 VIEW Ver: 21.01.01A.0521.20	▲ Maximum Reactions (lbs) Gravity Non-Gravity Loc R+ / R- / Rh / Rw / U / RL B 3590 /- /- /- /704 /- H 3590 /- /- /- /704 /- Wind reactions based on MWFRS B Brg Width = 3.5 Min Req = 1.5 H Brg Width = 3.5 Min Req = 1.5 Bearings B & H are a rigid surface. Members not listed have forces less than 375# Maximum Top Chord Forces Per Ply (lbs) Chords Tens.Comp. Chords Tens. Comp. B - C 664 -3410 E - F 1392 -7154 C - D 1190 -6118 F - G 1190 -6118 D - E 1392 -7154 G - H 664 -3410 Maximum Bot Chord Forces Per Ply (lbs) Chords Tens.Comp. Chords Tens. Comp. B - N 2991 -580 L - K 6215 -1221 N - M 3002 -577 K - J 3002 -577 M - L 6215 -1221 J - H 2991 -580 Maximum Web Forces Per Ply (lbs) Webs Tens.Comp. Webs Tens. Comp. C - M 3293 -648 L - F 995 -181 M - D 255 -799 F - K 255 -799 D - L 995 -181 K - G 3293 -648 E - L 169 -400
---	---	---	---	--

Lumber
Top chord: 2x4 SP M-31;
Bot chord: 2x4 SP M-31;
Webs: 2x4 SP #3; W2,W8 2x4 SP #2;

Nailnote
Nail Schedule: 0.131"x3", min. nails
Top Chord: 1 Row @12.00" o.c.
Bot Chord: 1 Row @12.00" o.c.
Webs : 1 Row @ 4" o.c.
Use equal spacing between rows and stagger nails in each row to avoid splitting.

Special Loads
----- (Lumber Dur.Fac.=1.25 / Plate Dur.Fac.=1.25)
TC: From 62 plf at -1.00 to 62 plf at 4.33
TC: From 31 plf at 4.33 to 31 plf at 32.17
TC: From 62 plf at 32.17 to 62 plf at 37.50
BC: From 4 plf at -1.00 to 4 plf at 0.00
BC: From 20 plf at 0.00 to 20 plf at 4.36
BC: From 10 plf at 4.36 to 10 plf at 32.14
BC: From 20 plf at 32.14 to 20 plf at 36.50
BC: From 4 plf at 36.50 to 4 plf at 37.50
TC: 223 lb Conc. Load at 4.36,32.14
TC: 186 lb Conc. Load at 6.40, 8.40,10.40,12.40,14.40,16.40,18.25,20.10,22.10,24.10,26.10,28.10,30.10
BC: 334 lb Conc. Load at 4.36,32.14
BC: 128 lb Conc. Load at 6.40, 8.40,10.40,12.40,14.40,16.40,18.25,20.10,22.10,24.10,26.10,28.10,30.10

Purlins
In lieu of structural panels use purlins to brace all flat TC @ 24" oc.

Wind
Wind loads and reactions based on MWFRS.
Wind loading based on both gable and hip roof types.

Additional Notes
The overall height of this truss excluding overhang is 2-7-15.

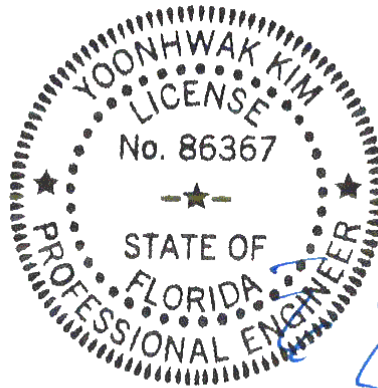

FL REG# 278, Yoonhwak Kim, FL PE #86367
02/03/2022

****WARNING** READ AND FOLLOW ALL NOTES ON THIS DRAWING!**
****IMPORTANT** FURNISH THIS DRAWING TO ALL CONTRACTORS INCLUDING THE INSTALLERS**
Trusses require extreme care in fabricating, handling, shipping, installing and bracing. Refer to and follow the latest edition of BCSI (Building Component Safety Information, by TPI and SBCA) for safety practices prior to performing these functions. Installers shall provide temporary bracing per BCSI. Unless noted otherwise, top chord shall have properly attached structural sheathing and bottom chord shall have a properly attached rigid ceiling. Locations shown for permanent lateral restraint of webs shall have bracing installed per BCSI sections B3, B7, or B10, as applicable. Apply plates to each face of truss and position as shown above and on the Joint Details, unless noted otherwise. Refer to drawings 160A-Z for standard plate positions. Refer to job's General Notes page for additional information.
Alpine, a division of ITW Building Components Group Inc. shall not be responsible for any deviation from this drawing, any failure to build the truss in conformance with ANSI/TPI 1, or for handling, shipping, installation and bracing of trusses. A seal on this drawing or cover page listing this drawing, indicates acceptance of professional engineering responsibility solely for the design shown. The suitability and use of this drawing for any structure is the responsibility of the Building Designer per ANSI/TPI 1 Sec.2.
For more information see these web sites: Alpine: alpineitw.com; TPI: tpinst.org; SBCA: sbcindustry.com; ICC: iccsafe.org; AWC: awc.org

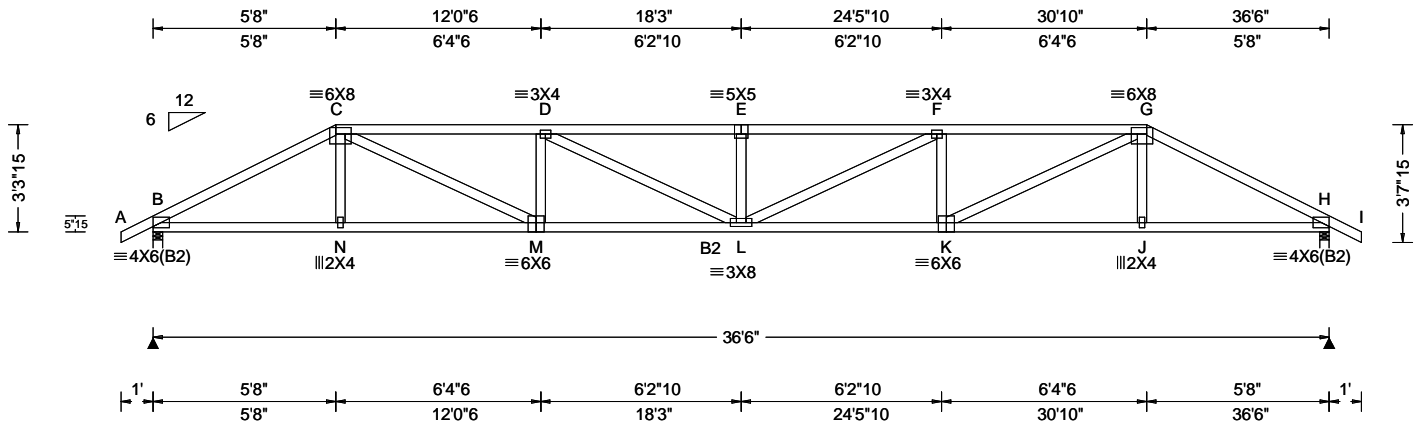

Loading Criteria (psf) TCLL: 20.00 TCDL: 10.00 BCLL: 0.00 BCDL: 10.00 Des Ld: 40.00 NCBCLL: 10.00 Soffit: 2.00 Load Duration: 1.25 Spacing: 24.0 "	Wind Criteria Wind Std: ASCE 7-16 Speed: 130 mph Enclosure: Closed Risk Category: II EXP: C Kzt: NA Mean Height: 15.00 ft TCDL: 5.0 psf BCDL: 5.0 psf MWFRS Parallel Dist: h/2 to h C&C Dist a: 3.65 ft Loc. from endwall: not in 9.00 ft GCp: 0.18 Wind Duration: 1.60	Snow Criteria (Pg,Pf in PSF) Pg: NA Ct: NA CAT: NA Pf: NA Ce: NA Lu: NA Cs: NA Snow Duration: NA Building Code: FBC 7th Ed. 2020 Res. TPI Std: 2014 Rep Fac: Yes FT/RT:20(0)/10(0) Plate Type(s): WAVE	Defl/CSI Criteria PP Deflection in loc L/defl L/# VERT(LL): 0.407 E 999 360 VERT(CL): 0.830 E 524 240 HORZ(LL): 0.080 C - - HORZ(TL): 0.164 C - - Creep Factor: 2.0 Max TC CSI: 0.959 Max BC CSI: 0.972 Max Web CSI: 0.821 VIEW Ver: 21.01.01A.0521.20	▲ Maximum Reactions (lbs) Gravity Non-Gravity Loc R+ / R- / Rh / Rw / U / RL B 1570 - / - / /878 /290 /101 H 1570 - / - / /878 /290 - /- Wind reactions based on MWFRS B Brg Width = 3.5 Min Req = 1.5 H Brg Width = 3.5 Min Req = 1.5 Bearings B & H are a rigid surface. Members not listed have forces less than 375# Maximum Top Chord Forces Per Ply (lbs) Chords Tens.Comp. Chords Tens. Comp. B - C 1227 -2700 E - F 2180 -4501 C - D 1928 -3960 F - G 1928 -3960 D - E 2180 -4501 G - H 1228 -2700
--	---	--	---	--

Lumber
Top chord: 2x4 SP #2;
Bot chord: 2x4 SP M-31; B2 2x4 SP #2;
Webs: 2x4 SP #3;

Purlins
In lieu of structural panels use purlins to brace all flat TC @ 24" oc.

Wind
Wind loads based on MWFRS with additional C&C member design.
Wind loading based on both gable and hip roof types.

Additional Notes
The overall height of this truss excluding overhang is 3-3-15.

Maximum Bot Chord Forces Per Ply (lbs)			
Chords	Tens.Comp.	Chords	Tens. Comp.
B - N	2331 -1013	L - K	4022 -1822
N - M	2333 -1009	K - J	2333 -998
M - L	4022 -1833	J - H	2331 -1002
Maximum Web Forces Per Ply (lbs)			
Webs	Tens.Comp.	Webs	Tens. Comp.
C - M	1809 -919	L - F	535 -255
M - D	458 -656	F - K	458 -656
D - L	535 -255	K - G	1809 -919

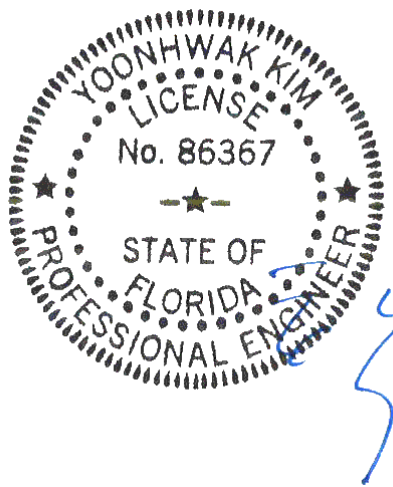

FL REG# 278, Yoonhwak Kim, FL PE #86367
02/03/2022

****WARNING** READ AND FOLLOW ALL NOTES ON THIS DRAWING!**
****IMPORTANT** FURNISH THIS DRAWING TO ALL CONTRACTORS INCLUDING THE INSTALLERS**
Trusses require extreme care in fabricating, handling, shipping, installing and bracing. Refer to and follow the latest edition of BCSI (Building Component Safety Information, by TPI and SBCA) for safety practices prior to performing these functions. Installers shall provide temporary bracing per BCSI. Unless noted otherwise, top chord shall have properly attached structural sheathing and bottom chord shall have a properly attached rigid ceiling. Locations shown for permanent lateral restraint of webs shall have bracing installed per BCSI sections B3, B7, or B10, as applicable. Apply plates to each face of truss and position as shown above and on the Joint Details, unless noted otherwise. Refer to drawings 160A-Z for standard plate positions. Refer to job's General Notes page for additional information.
Alpine, a division of ITW Building Components Group Inc. shall not be responsible for any deviation from this drawing, any failure to build the truss in conformance with ANSI/TPI 1, or for handling, shipping, installation and bracing of trusses. A seal on this drawing or cover page listing this drawing, indicates acceptance of professional engineering responsibility solely for the design shown. The suitability and use of this drawing for any structure is the responsibility of the Building Designer per ANSI/TPI 1 Sec.2.
For more information see these web sites: Alpine: alpineitw.com; TPI: tpinst.org; SBCA: sbcindustry.com; ICC: iccsafe.org; AWC: awc.org



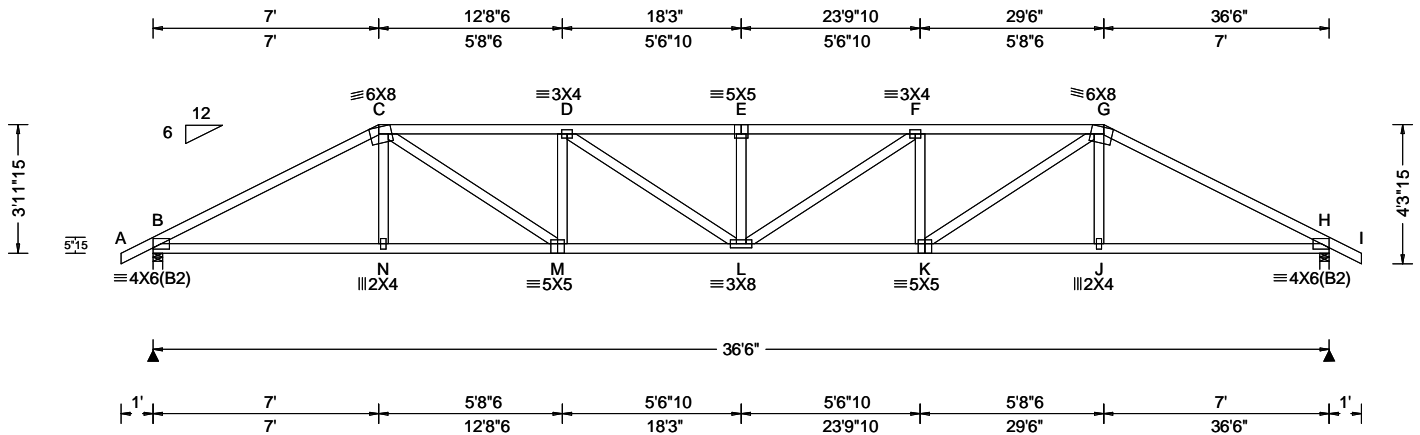

Loading Criteria (psf)	
TCLL:	20.00
TCDL:	10.00
BCLL:	0.00
BCDL:	10.00
Des Ld:	40.00
NCBCLL:	10.00
Soffit:	2.00
Load Duration:	1.25
Spacing:	24.0 "

Wind Criteria	
Wind Std:	ASCE 7-16
Speed:	130 mph
Enclosure:	Closed
Risk Category:	II
EXP:	C Kzt: NA
Mean Height:	15.00 ft
TCDL:	5.0 psf
BCDL:	5.0 psf
MWFRS Parallel Dist:	h/2 to h
C&C Dist a:	3.65 ft
Loc. from endwall:	not in 9.00 ft
GCp1:	0.18
Wind Duration:	1.60

Snow Criteria (Pg, Pf in PSF)	
Pg:	NA Ct: NA CAT: NA
Pf:	NA Ce: NA
Lu:	NA Cs: NA
Snow Duration:	NA
Building Code:	
FBC 7th Ed. 2020 Res.	
TPI Std: 2014	
Rep Fac: Yes	
FT/RT: 20(0)/10(0)	
Plate Type(s):	
WAVE	

Defl/CSI Criteria	
PP Deflection in	loc L/defl L/#
VERT(LL):	0.300 E 999 360
VERT(CL):	0.611 E 712 240
HORZ(LL):	0.083 J - -
HORZ(TL):	0.170 J - -
Creep Factor:	2.0
Max TC CSI:	0.747
Max BC CSI:	0.908
Max Web CSI:	0.540
VIEW Ver: 21.01.01A.0521.20	

▲ Maximum Reactions (lbs)					
Gravity			Non-Gravity		
Loc	R+ / R-	/ Rh	/ Rw	/ U	/ RL
B	1570 /-	/-	/891	/288	/118
H	1570 /-	/-	/891	/288	/-
Wind reactions based on MWFRS					
B	Brg Width = 3.5	Min Req = 1.9			
H	Brg Width = 3.5	Min Req = 1.9			
Bearings B & H are a rigid surface.					
Members not listed have forces less than 375#					
Maximum Top Chord Forces Per Ply (lbs)					
Chords	Tens.Comp.		Chords	Tens. Comp.	
B - C	1165	-2658	E - F	1765	-3684
C - D	1602	-3323	F - G	1602	-3323
D - E	1765	-3684	G - H	1166	-2658

Maximum Bot Chord Forces Per Ply (lbs)					
Chords	Tens.Comp.		Chords	Tens. Comp.	
B - N	2278	-944	L - K	3368	-1459
N - M	2281	-941	K - J	2281	-929
M - L	3368	-1471	J - H	2278	-933

Maximum Web Forces Per Ply (lbs)					
Webs	Tens.Comp.		Webs	Tens. Comp.	
C - M	1251	-653	L - F	383	-184
M - D	405	-574	F - K	405	-574
D - L	383	-184	K - G	1251	-653

Lumber

Top chord: 2x4 SP #2;
Bot chord: 2x4 SP #2;
Webs: 2x4 SP #3;

Purlins

In lieu of structural panels use purlins to brace all flat TC @ 24" oc.

Wind

Wind loads based on MWFRS with additional C&C member design.
Wind loading based on both gable and hip roof types.

Additional Notes

The overall height of this truss excluding overhang is 3-11-15.

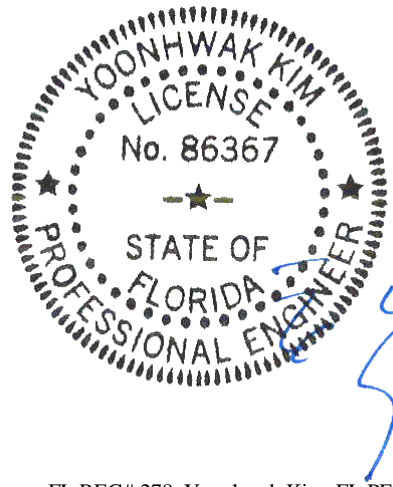

FL REG# 278, Yoonhwak Kim, FL PE #86367
02/03/2022

****WARNING** READ AND FOLLOW ALL NOTES ON THIS DRAWING!**
****IMPORTANT** FURNISH THIS DRAWING TO ALL CONTRACTORS INCLUDING THE INSTALLERS**
Trusses require extreme care in fabricating, handling, shipping, installing and bracing. Refer to and follow the latest edition of BCSI (Building Component Safety Information, by TPI and SBCA) for safety practices prior to performing these functions. Installers shall provide temporary bracing per BCSI. Unless noted otherwise, top chord shall have properly attached structural sheathing and bottom chord shall have a properly attached rigid ceiling. Locations shown for permanent lateral restraint of webs shall have bracing installed per BCSI sections B3, B7, or B10, as applicable. Apply plates to each face of truss and position as shown above and on the Joint Details, unless noted otherwise. Refer to drawings 160A-Z for standard plate positions. Refer to job's General Notes page for additional information.
Alpine, a division of ITW Building Components Group Inc. shall not be responsible for any deviation from this drawing, any failure to build the truss in conformance with ANSI/TPI 1, or for handling, shipping, installation and bracing of trusses. A seal on this drawing or cover page listing this drawing, indicates acceptance of professional engineering responsibility solely for the design shown. The suitability and use of this drawing for any structure is the responsibility of the Building Designer per ANSI/TPI 1 Sec.2.
For more information see these web sites: Alpine: alpineitw.com; TPI: tpinst.org; SBCA: sbcindustry.com; ICC: iccsafe.org; AWC: awc.org



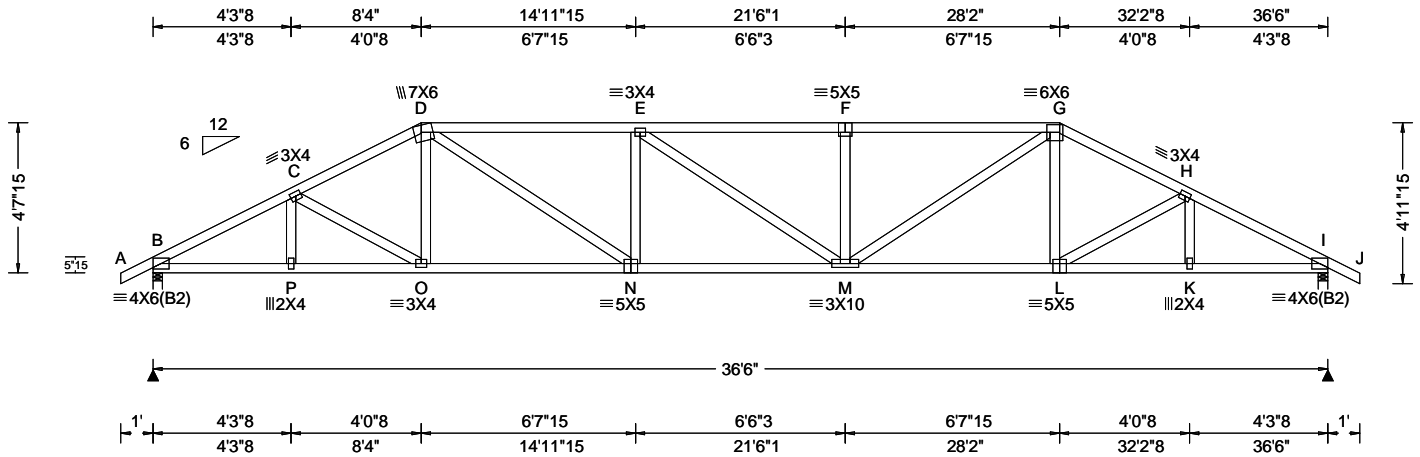

Loading Criteria (psf) TCLL: 20.00 TCDL: 10.00 BCLL: 0.00 BCDL: 10.00 Des Ld: 40.00 NCBCLL: 10.00 Soffit: 2.00 Load Duration: 1.25 Spacing: 24.0 "	Wind Criteria Wind Std: ASCE 7-16 Speed: 130 mph Enclosure: Closed Risk Category: II EXP: C Kzt: NA Mean Height: 15.00 ft TCDL: 5.0 psf BCDL: 5.0 psf MWFRS Parallel Dist: h/2 to h C&C Dist a: 3.65 ft Loc. from endwall: not in 9.00 ft GCp: 0.18 Wind Duration: 1.60	Snow Criteria (Pg,Pf in PSF) Pg: NA Ct: NA CAT: NA Pf: NA Ce: NA Lu: NA Cs: NA Snow Duration: NA Building Code: FBC 7th Ed. 2020 Res. TPI Std: 2014 Rep Fac: Yes FT/RT:20(0)/10(0) Plate Type(s): WAVE	Defl/CSI Criteria PP Deflection in loc L/defl L/# VERT(LL): 0.234 F 999 360 VERT(CL): 0.477 F 911 240 HORZ(LL): 0.078 K - - HORZ(TL): 0.158 K - - Creep Factor: 2.0 Max TC CSI: 0.899 Max BC CSI: 0.996 Max Web CSI: 0.591 VIEW Ver: 21.01.01A.0521.20	▲ Maximum Reactions (lbs) Gravity Non-Gravity Loc R+ / R- / Rh / Rw / U / RL B 1570 - / - / - / 902 / 287 / 136 I 1570 - / - / - / 902 / 287 / - Wind reactions based on MWFRS B Brg Width = 3.5 Min Req = 1.9 I Brg Width = 3.5 Min Req = 1.9 Bearings B & I are a rigid surface. Members not listed have forces less than 375# Maximum Top Chord Forces Per Ply (lbs) Chords Tens.Comp. Chords Tens. Comp. B - C 1071 -2652 F - G 1446 -3048 C - D 1120 -2516 G - H 1120 -2515 D - E 1435 -3029 H - I 1072 -2652 E - F 1446 -3048
--	---	--	---	--

Lumber

Top chord: 2x4 SP #2;
Bot chord: 2x4 SP #2;
Webs: 2x4 SP #3;

Purlins

In lieu of structural panels use purlins to brace all flat TC @ 24" oc.

Wind

Wind loads based on MWFRS with additional C&C member design.
Wind loading based on both gable and hip roof types.

Additional Notes

The overall height of this truss excluding overhang is 4-7-15.

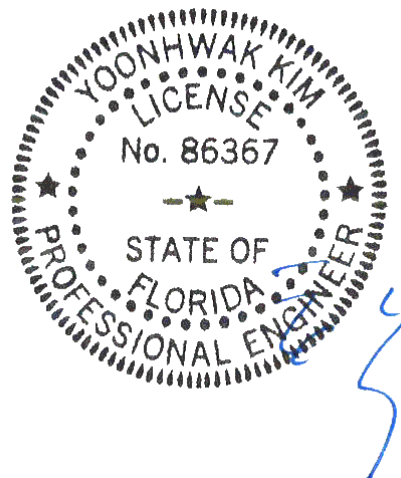

FL REG# 278, Yoonhwak Kim, FL PE #86367
02/03/2022

Maximum Bot Chord Forces Per Ply (lbs)			
Chords	Tens.Comp.	Chords	Tens. Comp.
B - P	2286 -889	M - L	2219 -859
P - O	2287 -892	L - K	2288 -882
O - N	2220 -870	K - I	2286 -879
N - M	3056 -1271		
Maximum Web Forces Per Ply (lbs)			
Webs	Tens.Comp.	Webs	Tens. Comp.
D - N	974 -504	F - M	337 -406
N - E	350 -414	M - G	992 -515

****WARNING** READ AND FOLLOW ALL NOTES ON THIS DRAWING!**
****IMPORTANT** FURNISH THIS DRAWING TO ALL CONTRACTORS INCLUDING THE INSTALLERS**
Trusses require extreme care in fabricating, handling, shipping, installing and bracing. Refer to and follow the latest edition of BCSI (Building Component Safety Information, by TPI and SBCA) for safety practices prior to performing these functions. Installers shall provide temporary bracing per BCSI. Unless noted otherwise, top chord shall have properly attached structural sheathing and bottom chord shall have a properly attached rigid ceiling. Locations shown for permanent lateral restraint of webs shall have bracing installed per BCSI sections B3, B7, or B10, as applicable. Apply plates to each face of truss and position as shown above and on the Joint Details, unless noted otherwise. Refer to drawings 160A-Z for standard plate positions. Refer to job's General Notes page for additional information.
Alpine, a division of ITW Building Components Group Inc. shall not be responsible for any deviation from this drawing, any failure to build the truss in conformance with ANSI/TPI 1, or for handling, shipping, installation and bracing of trusses. A seal on this drawing or cover page listing this drawing, indicates acceptance of professional engineering responsibility solely for the design shown. The suitability and use of this drawing for any structure is the responsibility of the Building Designer per ANSI/TPI 1 Sec.2.
For more information see these web sites: Alpine: alpineitw.com; TPI: tpinst.org; SBCA: sbcindustry.com; ICC: iccsafe.org; AWC: awc.org



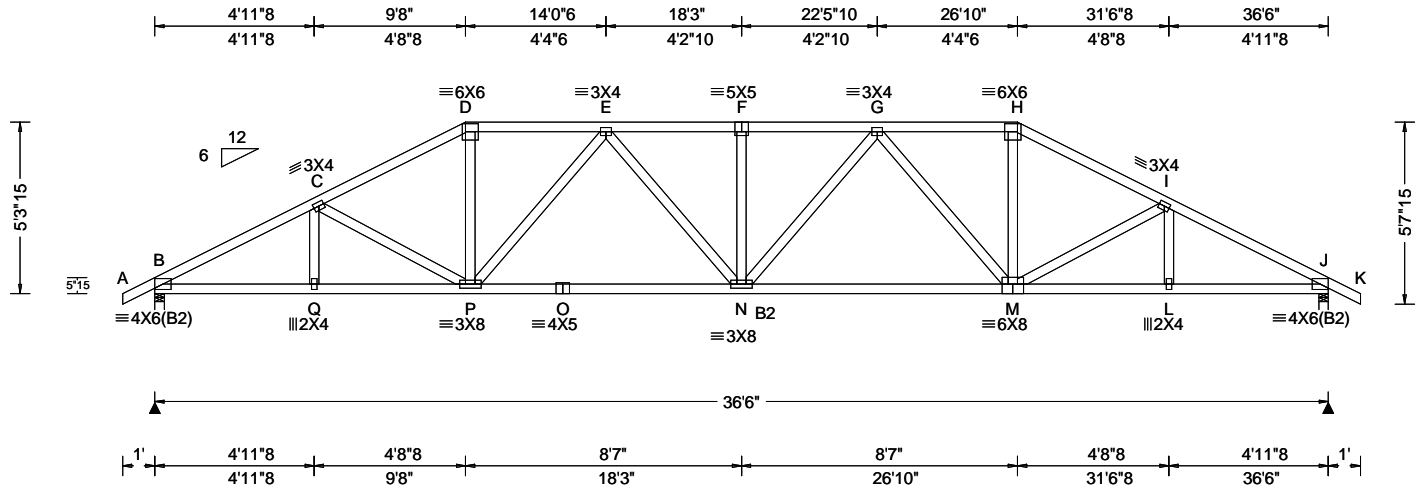

Loading Criteria (psf) TCLL: 20.00 TCDL: 10.00 BCLL: 0.00 BCDL: 10.00 Des Ld: 40.00 NCBCLL: 10.00 Soffit: 2.00 Load Duration: 1.25 Spacing: 24.0 "	Wind Criteria Wind Std: ASCE 7-16 Speed: 130 mph Enclosure: Closed Risk Category: II EXP: C Kzt: NA Mean Height: 15.00 ft TCDL: 5.0 psf BCDL: 5.0 psf MWFRS Parallel Dist: h to 2h C&C Dist a: 3.65 ft Loc. from endwall: not in 9.00 ft GCp: 0.18 Wind Duration: 1.60	Snow Criteria (Pg,Pf in PSF) Pg: NA Ct: NA CAT: NA Pf: NA Ce: NA Lu: NA Cs: NA Snow Duration: NA Building Code: FBC 7th Ed. 2020 Res. TPI Std: 2014 Rep Fac: Yes FT/RT:20(0)/10(0) Plate Type(s): WAVE	Defl/CSI Criteria PP Deflection in loc L/defl L/# VERT(LL): 0.193 F 999 360 VERT(CL): 0.393 F 999 240 HORZ(LL): 0.067 L - - HORZ(TL): 0.137 L - - Creep Factor: 2.0 Max TC CSI: 0.636 Max BC CSI: 0.895 Max Web CSI: 0.517 VIEW Ver: 21.01.01A.0521.20	▲ Maximum Reactions (lbs) Gravity Loc R+ / R- / Rh / Rw / U / RL Non-Gravity B 1570 - / - / 912 / 98 / 154 J 1570 - / - / 912 / 98 - / - Wind reactions based on MWFRS B Brg Width = 3.5 Min Req = 1.5 J Brg Width = 3.5 Min Req = 1.5 Bearings B & J are a rigid surface. Members not listed have forces less than 375# Maximum Top Chord Forces Per Ply (lbs) Chords Tens.Comp. Chords Tens. Comp. B - C 1023 -2672 F - G 1239 -2715 C - D 1034 -2426 G - H 983 -2137 D - E 982 -2139 H - I 1034 -2425 E - F 1239 -2715 I - J 1023 -2672
--	--	--	---	--

Lumber
Top chord: 2x4 SP #2;
Bot chord: 2x4 SP M-31; B2 2x4 SP #2;
Webs: 2x4 SP #3;

Purlins
In lieu of structural panels use purlins to brace all flat TC @ 24" oc.

Wind
Wind loads based on MWFRS with additional C&C member design.
Wind loading based on both gable and hip roof types.

Additional Notes
The overall height of this truss excluding overhang is 5-3-15.

Maximum Bot Chord Forces Per Ply (lbs)

Chords	Tens.Comp.	Chords	Tens. Comp.
B - Q	2307 -845	N - M	2535 -979
Q - P	2308 -847	M - L	2309 -836
P - O	2536 -990	L - J	2308 -834
O - N	2536 -990		

Maximum Web Forces Per Ply (lbs)

Webs	Tens.Comp.	Webs	Tens. Comp.
D - P	759 -268	G - M	385 -621
P - E	386 -620	M - H	758 -268

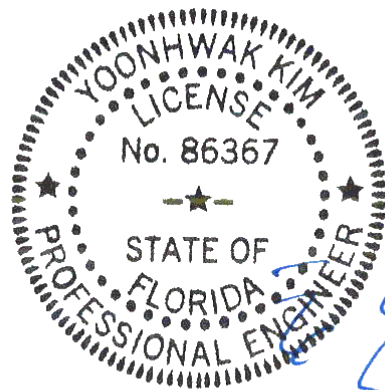

FL REG# 278, Yoonhwak Kim, FL PE #86367
02/03/2022

****WARNING** READ AND FOLLOW ALL NOTES ON THIS DRAWING!**
****IMPORTANT** FURNISH THIS DRAWING TO ALL CONTRACTORS INCLUDING THE INSTALLERS**
Trusses require extreme care in fabricating, handling, shipping, installing and bracing. Refer to and follow the latest edition of BCSI (Building Component Safety Information, by TPI and SBCA) for safety practices prior to performing these functions. Installers shall provide temporary bracing per BCSI. Unless noted otherwise, top chord shall have properly attached structural sheathing and bottom chord shall have a properly attached rigid ceiling. Locations shown for permanent lateral restraint of webs shall have bracing installed per BCSI sections B3, B7, or B10, as applicable. Apply plates to each face of truss and position as shown above and on the Joint Details, unless noted otherwise. Refer to drawings 160A-Z for standard plate positions. Refer to job's General Notes page for additional information.
Alpine, a division of ITW Building Components Group Inc. shall not be responsible for any deviation from this drawing, any failure to build the truss in conformance with ANSI/TPI 1, or for handling, shipping, installation and bracing of trusses. A seal on this drawing or cover page listing this drawing, indicates acceptance of professional engineering responsibility solely for the design shown. The suitability and use of this drawing for any structure is the responsibility of the Building Designer per ANSI/TPI 1 Sec.2.
For more information see these web sites: Alpine: alpineitw.com; TPI: tpinst.org; SBCA: sbcindustry.com; ICC: iccsafe.org; AWC: awc.org



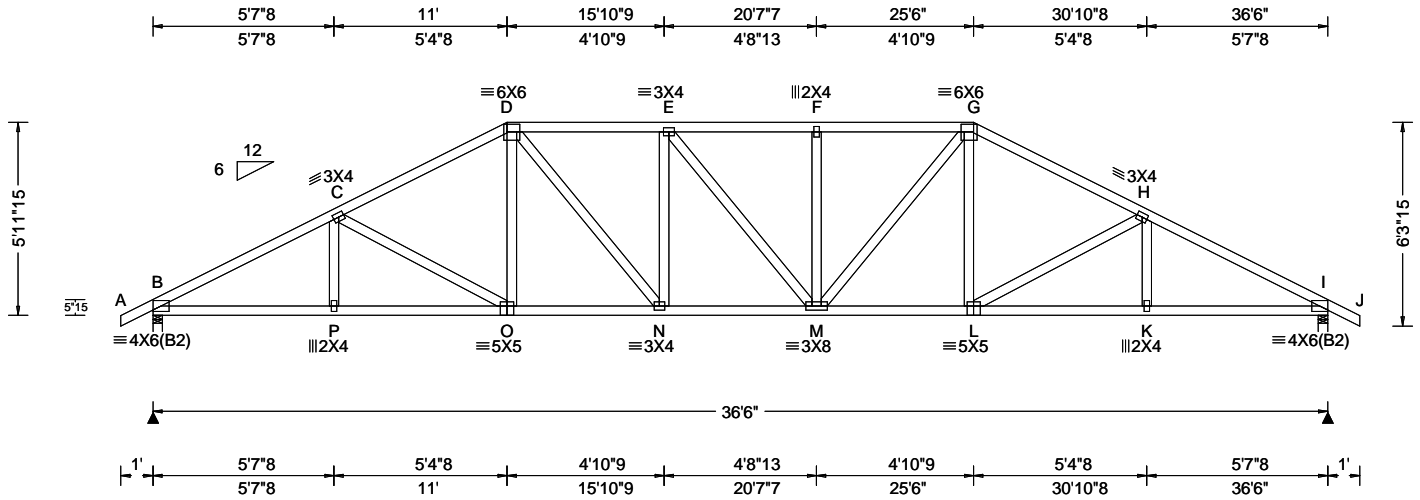

Loading Criteria (psf) TCLL: 20.00 TCDL: 10.00 BCLL: 0.00 BCDL: 10.00 Des Ld: 40.00 NCBCLL: 10.00 Soffit: 2.00 Load Duration: 1.25 Spacing: 24.0 "	Wind Criteria Wind Std: ASCE 7-16 Speed: 130 mph Enclosure: Closed Risk Category: II EXP: C Kzt: NA Mean Height: 15.00 ft TCDL: 5.0 psf BCDL: 5.0 psf MWFRS Parallel Dist: h to 2h C&C Dist a: 3.65 ft Loc. from endwall: not in 9.00 ft GCp: 0.18 Wind Duration: 1.60	Snow Criteria (Pg,Pf in PSF) Pg: NA Ct: NA CAT: NA Pf: NA Ce: NA Lu: NA Cs: NA Snow Duration: NA Building Code: FBC 7th Ed. 2020 Res. TPI Std: 2014 Rep Fac: Yes FT/RT:20(0)/10(0) Plate Type(s): WAVE	Defl/CSI Criteria PP Deflection in loc L/def L/# VERT(LL): 0.183 F 999 360 VERT(CL): 0.373 F 999 240 HORZ(LL): 0.077 K - - HORZ(TL): 0.156 K - - Creep Factor: 2.0 Max TC CSI: 0.701 Max BC CSI: 0.985 Max Web CSI: 0.284 VIEW Ver: 21.01.01A.0521.20	▲ Maximum Reactions (lbs) Gravity Non-Gravity Loc R+ / R- / Rh / Rw / U / RL B 1570 - / - / 920 / 90 / 172 I 1570 - / - / 920 / 90 / - Wind reactions based on MWFRS B Brg Width = 3.5 Min Req = 1.9 I Brg Width = 3.5 Min Req = 1.9 Bearings B & I are a rigid surface. Members not listed have forces less than 375# Maximum Top Chord Forces Per Ply (lbs) Chords Tens.Comp. Chords Tens. Comp. B - C 961 -2687 F - G 1066 -2348 C - D 964 -2332 G - H 964 -2332 D - E 1059 -2337 H - I 962 -2687 E - F 1065 -2347
--	--	--	--	--

Lumber
Top chord: 2x4 SP #2;
Bot chord: 2x4 SP #2;
Webs: 2x4 SP #3;

Purlins
In lieu of structural panels use purlins to brace all flat TC @ 24" oc.

Wind
Wind loads based on MWFRS with additional C&C member design.
Wind loading based on both gable and hip roof types.

Additional Notes
The overall height of this truss excluding overhang is 5-11-15.

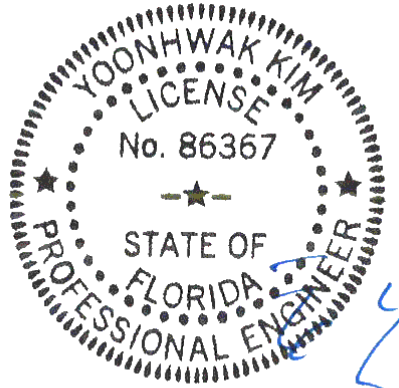

FL REG# 278, Yoonhwak Kim, FL PE #86367
02/03/2022

****WARNING** READ AND FOLLOW ALL NOTES ON THIS DRAWING!**
****IMPORTANT** FURNISH THIS DRAWING TO ALL CONTRACTORS INCLUDING THE INSTALLERS**
Trusses require extreme care in fabricating, handling, shipping, installing and bracing. Refer to and follow the latest edition of BCSI (Building Component Safety Information, by TPI and SBCA) for safety practices prior to performing these functions. Installers shall provide temporary bracing per BCSI. Unless noted otherwise, top chord shall have properly attached structural sheathing and bottom chord shall have a properly attached rigid ceiling. Locations shown for permanent lateral restraint of webs shall have bracing installed per BCSI sections B3, B7, or B10, as applicable. Apply plates to each face of truss and position as shown above and on the Joint Details, unless noted otherwise. Refer to drawings 160A-Z for standard plate positions. Refer to job's General Notes page for additional information.
Alpine, a division of ITW Building Components Group Inc. shall not be responsible for any deviation from this drawing, any failure to build the truss in conformance with ANSI/TPI 1, or for handling, shipping, installation and bracing of trusses. A seal on this drawing or cover page listing this drawing, indicates acceptance of professional engineering responsibility solely for the design shown. The suitability and use of this drawing for any structure is the responsibility of the Building Designer per ANSI/TPI 1 Sec.2.
For more information see these web sites: Alpine: alpineitw.com; TPI: tpinst.org; SBCA: sbcindustry.com; ICC: iccsafe.org; AWC: awc.org



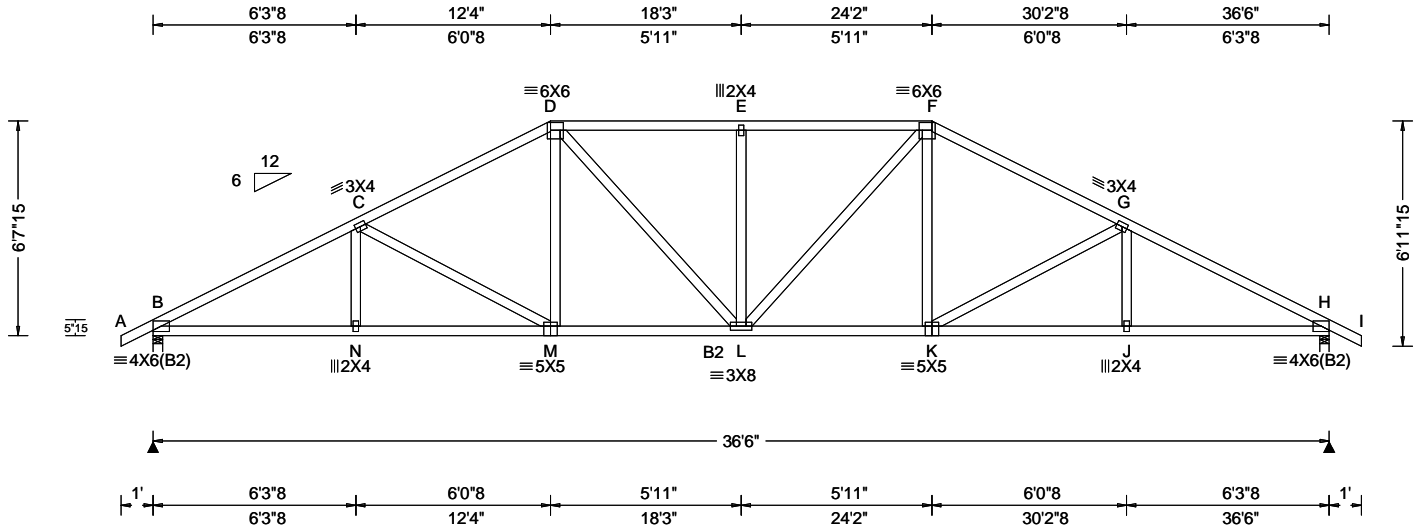

Loading Criteria (psf) TCLL: 20.00 TCDL: 10.00 BCLL: 0.00 BCDL: 10.00 Des Ld: 40.00 NCBCLL: 10.00 Soffit: 2.00 Load Duration: 1.25 Spacing: 24.0 "	Wind Criteria Wind Std: ASCE 7-16 Speed: 130 mph Enclosure: Closed Risk Category: II EXP: C Kzt: NA Mean Height: 15.00 ft TCDL: 5.0 psf BCDL: 5.0 psf MWFRS Parallel Dist: h to 2h C&C Dist a: 3.65 ft Loc. from endwall: not in 9.00 ft GCp: 0.18 Wind Duration: 1.60	Snow Criteria (Pg,Pf in PSF) Pg: NA Ct: NA CAT: NA Pf: NA Ce: NA Lu: NA Cs: NA Snow Duration: NA Building Code: FBC 7th Ed. 2020 Res. TPI Std: 2014 Rep Fac: Yes FT/RT:20(0)/10(0) Plate Type(s): WAVE	Defl/CSI Criteria PP Deflection in loc L/def L/# VERT(LL): 0.159 E 999 360 VERT(CL): 0.323 E 999 240 HORZ(LL): 0.061 J - - HORZ(TL): 0.125 J - - Creep Factor: 2.0 Max TC CSI: 0.681 Max BC CSI: 0.548 Max Web CSI: 0.404 VIEW Ver: 21.01.01A.0521.20	▲ Maximum Reactions (lbs) Gravity Non-Gravity Loc R+ / R- / Rh / Rw / U / RL B 1570 /- /- /927 /82 /189 H 1570 /- /- /927 /82 /- Wind reactions based on MWFRS B Brg Width = 3.5 Min Req = 1.5 H Brg Width = 3.5 Min Req = 1.5 Bearings B & H are a rigid surface. Members not listed have forces less than 375# Maximum Top Chord Forces Per Ply (lbs) Chords Tens.Comp. Chords Tens. Comp. B - C 894 -2680 E - F 947 -2153 C - D 883 -2242 F - G 883 -2242 D - E 947 -2153 G - H 895 -2680
--	--	--	--	--

Lumber

Top chord: 2x4 SP #2;
Bot chord: 2x4 SP M-31; B2 2x4 SP #2;
Webs: 2x4 SP #3;

Purlins

In lieu of structural panels use purlins to brace all flat
TC @ 24" oc.

Wind

Wind loads based on MWFRS with additional C&C
member design.
Wind loading based on both gable and hip roof types.

Additional Notes

The overall height of this truss excluding overhang is
6-7-15.

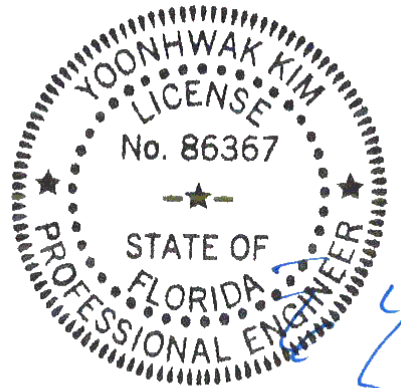

FL REG# 278, Yoonhwak Kim, FL PE #86367
02/03/2022

Maximum Bot Chord Forces Per Ply (lbs)			
Chords	Tens.Comp.	Chords	Tens. Comp.
B - N	2308 -719	L - K	1932 -581
N - M	2307 -721	K - J	2307 -710
M - L	1932 -592	J - H	2308 -708
Maximum Web Forces Per Ply (lbs)			
Webs	Tens.Comp.	Webs	Tens. Comp.
C - M	149 -431	F - K	413 -24
D - M	413 -24	K - G	149 -431

****WARNING** READ AND FOLLOW ALL NOTES ON THIS DRAWING!**
****IMPORTANT** FURNISH THIS DRAWING TO ALL CONTRACTORS INCLUDING THE INSTALLERS**
Trusses require extreme care in fabricating, handling, shipping, installing and bracing. Refer to and follow the latest edition of BCSI (Building Component Safety Information, by TPI and SBCA) for safety practices prior to performing these functions. Installers shall provide temporary bracing per BCSI. Unless noted otherwise, top chord shall have properly attached structural sheathing and bottom chord shall have a properly attached rigid ceiling. Locations shown for permanent lateral restraint of webs shall have bracing installed per BCSI sections B3, B7, or B10, as applicable. Apply plates to each face of truss and position as shown above and on the Joint Details, unless noted otherwise. Refer to drawings 160A-Z for standard plate positions. Refer to job's General Notes page for additional information.
Alpine, a division of ITW Building Components Group Inc. shall not be responsible for any deviation from this drawing, any failure to build the truss in conformance with ANSI/TPI 1, or for handling, shipping, installation and bracing of trusses. A seal on this drawing or cover page listing this drawing, indicates acceptance of professional engineering responsibility solely for the design shown. The suitability and use of this drawing for any structure is the responsibility of the Building Designer per ANSI/TPI 1 Sec.2.
For more information see these web sites: Alpine: alpineitw.com; TPI: tpinst.org; SBCA: sbcindustry.com; ICC: iccsafe.org; AWC: awc.org



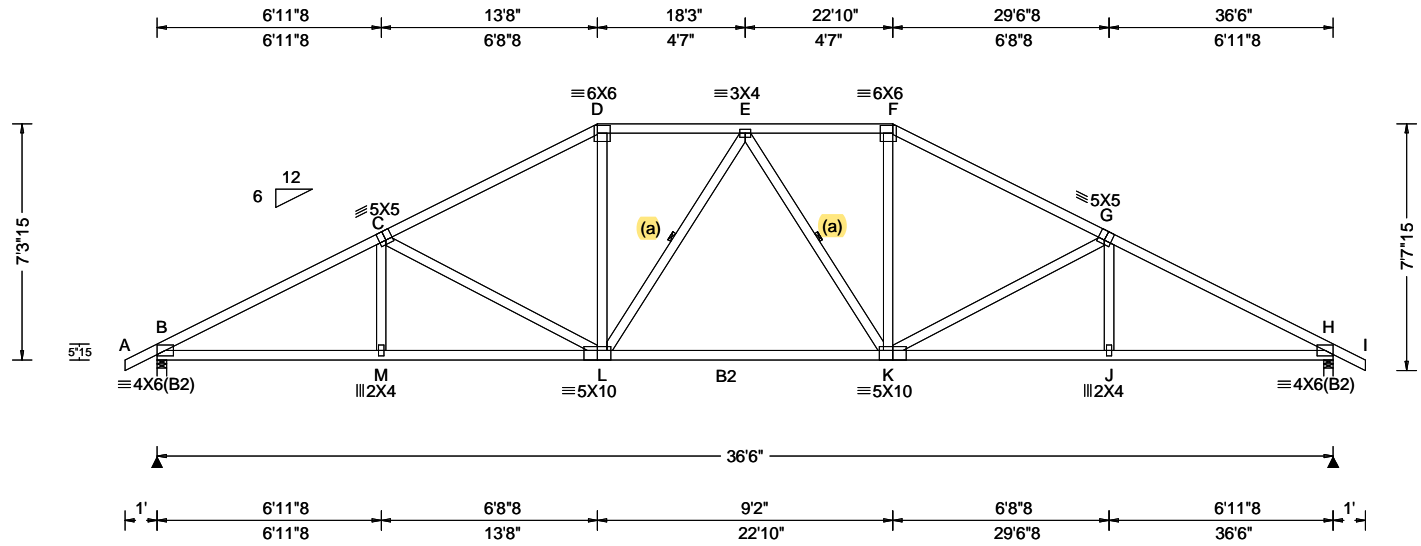

Loading Criteria (psf)	Wind Criteria	Snow Criteria (Pg,Pf in PSF)	Defl/CSI Criteria	▲ Maximum Reactions (lbs)
TCLL: 20.00 TCDL: 10.00 BCLL: 0.00 BCDL: 10.00 Des Ld: 40.00 NCBCLL: 10.00 Soffit: 2.00 Load Duration: 1.25 Spacing: 24.0 "	Wind Std: ASCE 7-16 Speed: 130 mph Enclosure: Closed Risk Category: II EXP: C Kzt: NA Mean Height: 15.00 ft TCDL: 5.0 psf BCDL: 5.0 psf MWFRS Parallel Dist: h to 2h C&C Dist a: 3.65 ft Loc. from endwall: not in 9.00 ft GCpi: 0.18 Wind Duration: 1.60	Pg: NA Ct: NA CAT: NA Pf: NA Ce: NA Lu: NA Cs: NA Snow Duration: NA Building Code: FBC 7th Ed. 2020 Res. TPI Std: 2014 Rep Fac: Yes FT/RT:20(0)/10(0) Plate Type(s): WAVE	PP Deflection in loc L/def L/# VERT(LL): 0.148 E 999 360 VERT(CL): 0.302 E 999 240 HORZ(LL): 0.059 J - - HORZ(TL): 0.121 J - - Creep Factor: 2.0 Max TC CSI: 0.702 Max BC CSI: 0.796 Max Web CSI: 0.600 VIEW Ver: 21.01.01A.0521.20	Gravity Loc R+ / R- / Rh / Rw / U / RL B 1566 /- /- /932 /71 /207 H 1566 /- /- /932 /71 /- Non-Gravity Wind reactions based on MWFRS B Brg Width = 3.5 Min Req = 1.5 H Brg Width = 3.5 Min Req = 1.5 Bearings B & H are a rigid surface. Members not listed have forces less than 375# Maximum Top Chord Forces Per Ply (lbs) Chords Tens.Comp. Chords Tens. Comp. B - C 828 -2661 E - F 775 -1838 C - D 792 -2138 F - G 792 -2138 D - E 775 -1838 G - H 828 -2661 Maximum Bot Chord Forces Per Ply (lbs) Chords Tens.Comp. Chords Tens. Comp. B - M 2287 -653 K - J 2285 -644 M - L 2285 -655 J - H 2287 -642 L - K 1912 -543 Maximum Web Forces Per Ply (lbs) Webs Tens.Comp. Webs Tens. Comp. C - L 190 -522 K - F 557 -135 D - L 557 -135 K - G 190 -522

Lumber

Top chord: 2x4 SP #2;
Bot chord: 2x4 SP M-31; B2 2x4 SP #2;
Webs: 2x4 SP #3;

Bracing

(a) Continuous lateral restraint equally spaced on member.

Purlins

In lieu of structural panels use purlins to brace all flat TC @ 24" oc.

Wind

Wind loads based on MWFRS with additional C&C member design.
Wind loading based on both gable and hip roof types.

Additional Notes

The overall height of this truss excluding overhang is 7-3-15.

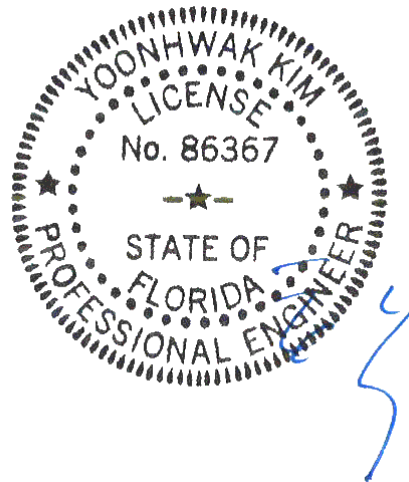

FL REG# 278, Yoonhwak Kim, FL PE #86367
02/03/2022

****WARNING** READ AND FOLLOW ALL NOTES ON THIS DRAWING!**
****IMPORTANT** FURNISH THIS DRAWING TO ALL CONTRACTORS INCLUDING THE INSTALLERS**
Trusses require extreme care in fabricating, handling, shipping, installing and bracing. Refer to and follow the latest edition of BCSI (Building Component Safety Information, by TPI and SBCA) for safety practices prior to performing these functions. Installers shall provide temporary bracing per BCSI. Unless noted otherwise, top chord shall have properly attached structural sheathing and bottom chord shall have a properly attached rigid ceiling. Locations shown for permanent lateral restraint of webs shall have bracing installed per BCSI sections B3, B7, or B10, as applicable. Apply plates to each face of truss and position as shown above and on the Joint Details, unless noted otherwise. Refer to drawings 160A-Z for standard plate positions. Refer to job's General Notes page for additional information.
Alpine, a division of ITW Building Components Group Inc. shall not be responsible for any deviation from this drawing, any failure to build the truss in conformance with ANSI/TPI 1, or for handling, shipping, installation and bracing of trusses. A seal on this drawing or cover page listing this drawing, indicates acceptance of professional engineering responsibility solely for the design shown. The suitability and use of this drawing for any structure is the responsibility of the Building Designer per ANSI/TPI 1 Sec.2.
For more information see these web sites: Alpine: alpineitw.com; TPI: tpinst.org; SBCA: sbcindustry.com; ICC: iccsafe.org; AWC: awc.org



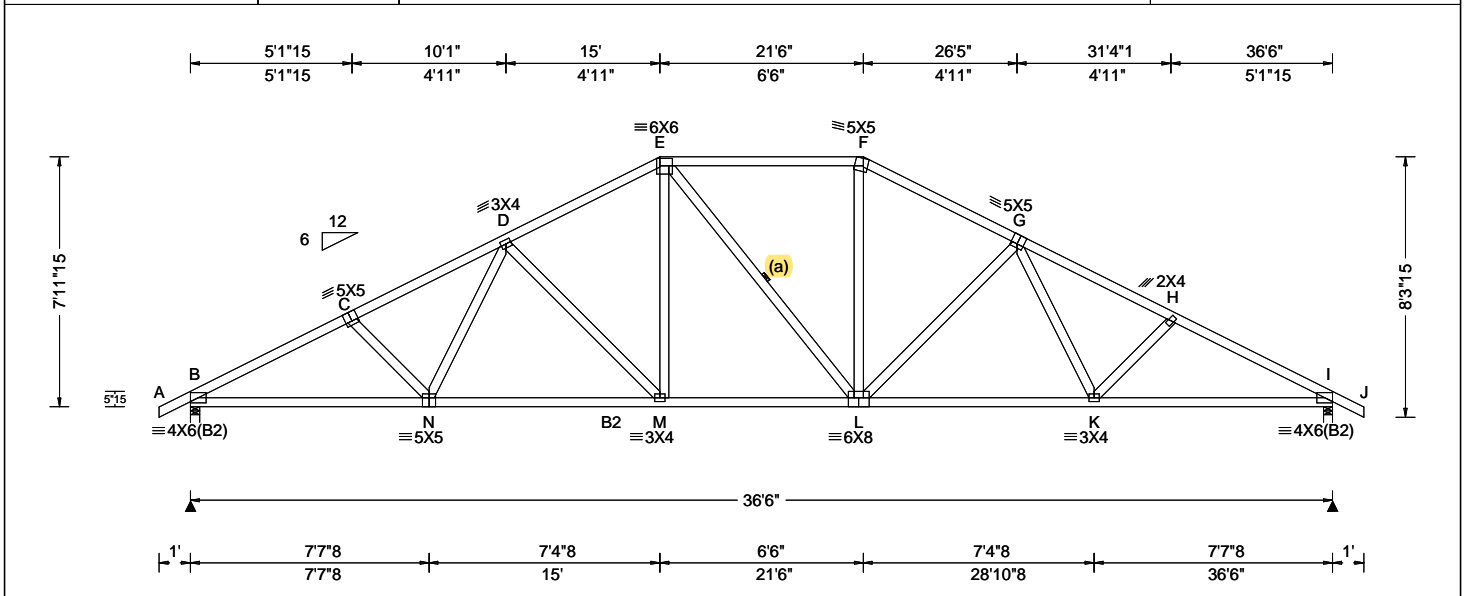

Loading Criteria (psf) TCLL: 20.00 TCDL: 10.00 BCLL: 0.00 BCDL: 10.00 Des Ld: 40.00 NCBCLL: 10.00 Soffit: 2.00 Load Duration: 1.25 Spacing: 24.0 "	Wind Criteria Wind Std: ASCE 7-16 Speed: 130 mph Enclosure: Closed Risk Category: II EXP: C Kzt: NA Mean Height: 15.00 ft TCDL: 5.0 psf BCDL: 5.0 psf MWFRS Parallel Dist: h to 2h C&C Dist a: 3.65 ft Loc. from endwall: not in 9.00 ft GCp: 0.18 Wind Duration: 1.60	Snow Criteria (Pg,Pf in PSF) Pg: NA Ct: NA CAT: NA Pf: NA Ce: NA Lu: NA Cs: NA Snow Duration: NA Building Code: FBC 7th Ed. 2020 Res. TPI Std: 2014 Rep Fac: Yes FT/RT:20(0)/10(0) Plate Type(s): WAVE	Defl/CSI Criteria PP Deflection in loc L/def L/# VERT(LL): 0.166 M 999 360 VERT(CL): 0.326 M 999 240 HORZ(LL): 0.068 K - - HORZ(TL): 0.134 K - - Creep Factor: 2.0 Max TC CSI: 0.718 Max BC CSI: 0.719 Max Web CSI: 0.494 VIEW Ver: 21.01.01A.0521.20	▲ Maximum Reactions (lbs) Gravity Non-Gravity Loc R+ / R- / Rh / Rw / U / RL B 1633 -/- /- /935 /41 /225 I 1624 -/- /- /935 /41 -/ Wind reactions based on MWFRS B Brg Width = 3.5 Min Req = 1.5 I Brg Width = 3.5 Min Req = 1.5 Bearings B & I are a rigid surface. Members not listed have forces less than 375# Maximum Top Chord Forces Per Ply (lbs) Chords Tens.Comp. Chords Tens. Comp. B - C 770 -2832 F - G 720 -2113 C - D 757 -2637 G - H 755 -2616 D - E 722 -2145 H - I 769 -2812 E - F 702 -1840
--	--	--	--	---

Lumber
Top chord: 2x4 SP #2;
Bot chord: 2x4 SP M-31; B2 2x4 SP #2;
Webs: 2x4 SP #3;

Bracing
(a) Continuous lateral restraint equally spaced on member.

Loading
Truss passed check for 20 psf additional bottom chord live load in areas with 42"-high x 24"-wide clearance.

Purlins
In lieu of structural panels use purlins to brace all flat TC @ 24" oc.

Wind
Wind loads based on MWFRS with additional C&C member design.
Wind loading based on both gable and hip roof types.

Additional Notes
The overall height of this truss excluding overhang is 7-11-15.

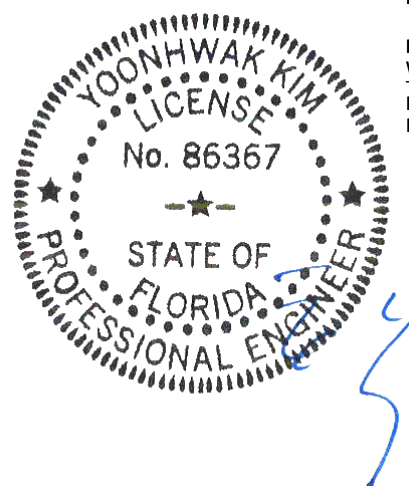

FL REG# 278, Yoonhwak Kim, FL PE #86367
02/03/2022

****WARNING** READ AND FOLLOW ALL NOTES ON THIS DRAWING!**
****IMPORTANT** FURNISH THIS DRAWING TO ALL CONTRACTORS INCLUDING THE INSTALLERS**
Trusses require extreme care in fabricating, handling, shipping, installing and bracing. Refer to and follow the latest edition of BCSI (Building Component Safety Information, by TPI and SBCA) for safety practices prior to performing these functions. Installers shall provide temporary bracing per BCSI. Unless noted otherwise, top chord shall have properly attached structural sheathing and bottom chord shall have a properly attached rigid ceiling. Locations shown for permanent lateral restraint of webs shall have bracing installed per BCSI sections B3, B7, or B10, as applicable. Apply plates to each face of truss and position as shown above and on the Joint Details, unless noted otherwise. Refer to drawings 160A-Z for standard plate positions. Refer to job's General Notes page for additional information.
Alpine, a division of ITW Building Components Group Inc. shall not be responsible for any deviation from this drawing, any failure to build the truss in conformance with ANSI/TPI 1, or for handling, shipping, installation and bracing of trusses. A seal on this drawing or cover page listing this drawing, indicates acceptance of professional engineering responsibility solely for the design shown. The suitability and use of this drawing for any structure is the responsibility of the Building Designer per ANSI/TPI 1 Sec.2.
For more information see these web sites: Alpine: alpineitw.com; TPI: tpinst.org; SBCA: sbcindustry.com; ICC: iccsafe.org; AWC: awc.org



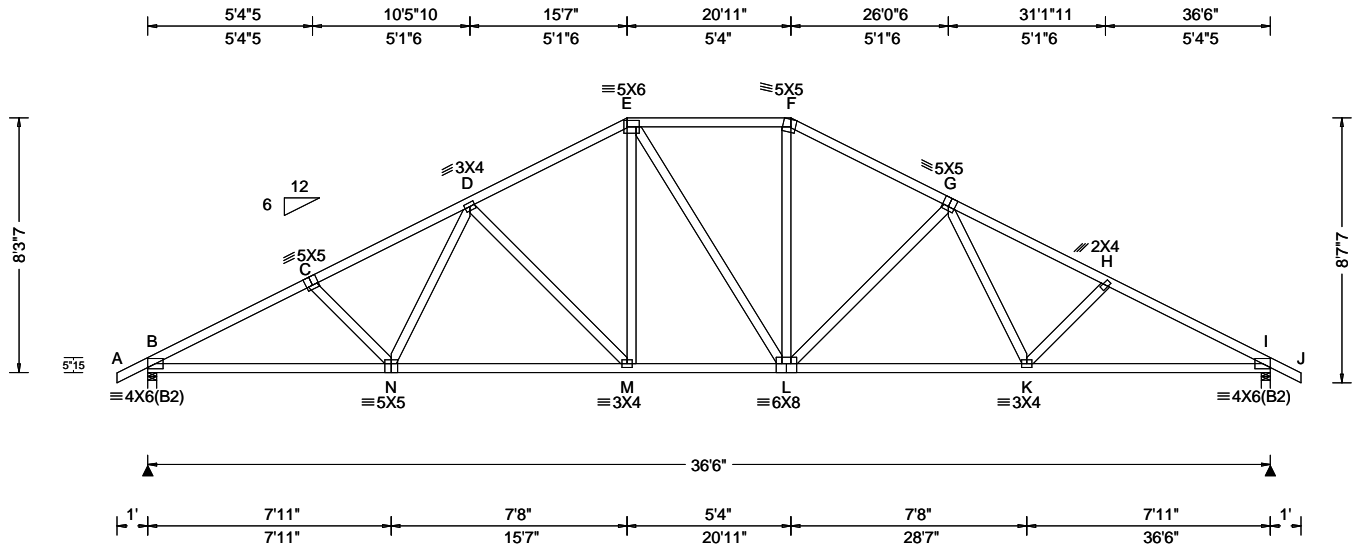

Loading Criteria (psf) TCLL: 20.00 TCCL: 10.00 BCCL: 0.00 BCDL: 10.00 Des Ld: 40.00 NCBCLL: 10.00 Soffit: 2.00 Load Duration: 1.25 Spacing: 24.0 "	Wind Criteria Wind Std: ASCE 7-16 Speed: 130 mph Enclosure: Closed Risk Category: II EXP: C Kzt: NA Mean Height: 15.00 ft TCCL: 5.0 psf BCDL: 5.0 psf MWFRS Parallel Dist: h to 2h C&C Dist a: 3.65 ft Loc. from endwall: not in 9.00 ft GCp: 0.18 Wind Duration: 1.60	Snow Criteria (Pg,Pf in PSF) Pg: NA Ct: NA CAT: NA Pf: NA Ce: NA Lu: NA Cs: NA Snow Duration: NA Building Code: FBC 7th Ed. 2020 Res. TPI Std: 2014 Rep Fac: Yes FT/RT:20(0)/10(0) Plate Type(s): WAVE	Defl/CSI Criteria PP Deflection in loc L/defl L/# VERT(LL): 0.164 M 999 360 VERT(CL): 0.334 M 999 240 HORZ(LL): 0.075 K - - HORZ(TL): 0.153 K - - Creep Factor: 2.0 Max TC CSI: 0.729 Max BC CSI: 0.967 Max Web CSI: 0.586 VIEW Ver: 21.01.01A.0521.20	▲ Maximum Reactions (lbs) <table style="width:100%; border-collapse: collapse;"> <thead> <tr> <th rowspan="2">Loc</th> <th colspan="3">Gravity</th> <th colspan="3">Non-Gravity</th> </tr> <tr> <th>R+</th> <th>/R-</th> <th>/Rh</th> <th>/Rw</th> <th>/U</th> <th>/RL</th> </tr> </thead> <tbody> <tr> <td>B</td> <td>1570</td> <td>-</td> <td>-</td> <td>/936</td> <td>/39</td> <td>/233</td> </tr> <tr> <td>I</td> <td>1570</td> <td>-</td> <td>-</td> <td>/936</td> <td>/39</td> <td>-</td> </tr> </tbody> </table> <p>Wind reactions based on MWFRS B Brg Width = 3.5 Min Req = 1.9 I Brg Width = 3.5 Min Req = 1.9 Bearings B & I are a rigid surface. Members not listed have forces less than 375# Maximum Top Chord Forces Per Ply (lbs)</p> <table style="width:100%; border-collapse: collapse;"> <thead> <tr> <th>Chords</th> <th>Tens.Comp.</th> <th>Chords</th> <th>Tens. Comp.</th> </tr> </thead> <tbody> <tr> <td>B - C</td> <td>736 -2699</td> <td>F - G</td> <td>681 -1943</td> </tr> <tr> <td>C - D</td> <td>723 -2495</td> <td>G - H</td> <td>722 -2497</td> </tr> <tr> <td>D - E</td> <td>683 -1952</td> <td>H - I</td> <td>736 -2701</td> </tr> <tr> <td>E - F</td> <td>664 -1680</td> <td></td> <td></td> </tr> </tbody> </table>	Loc	Gravity			Non-Gravity			R+	/R-	/Rh	/Rw	/U	/RL	B	1570	-	-	/936	/39	/233	I	1570	-	-	/936	/39	-	Chords	Tens.Comp.	Chords	Tens. Comp.	B - C	736 -2699	F - G	681 -1943	C - D	723 -2495	G - H	722 -2497	D - E	683 -1952	H - I	736 -2701	E - F	664 -1680		
Loc	Gravity			Non-Gravity																																															
	R+	/R-	/Rh	/Rw	/U	/RL																																													
B	1570	-	-	/936	/39	/233																																													
I	1570	-	-	/936	/39	-																																													
Chords	Tens.Comp.	Chords	Tens. Comp.																																																
B - C	736 -2699	F - G	681 -1943																																																
C - D	723 -2495	G - H	722 -2497																																																
D - E	683 -1952	H - I	736 -2701																																																
E - F	664 -1680																																																		

Lumber

Top chord: 2x4 SP #2;
 Bot chord: 2x4 SP #2;
 Webs: 2x4 SP #3;

Purlins

In lieu of structural panels use purlins to brace all flat TC @ 24" oc.

Wind

Wind loads based on MWFRS with additional C&C member design.
 Wind loading based on both gable and hip roof types.

Additional Notes

The overall height of this truss excluding overhang is 8-3-7.

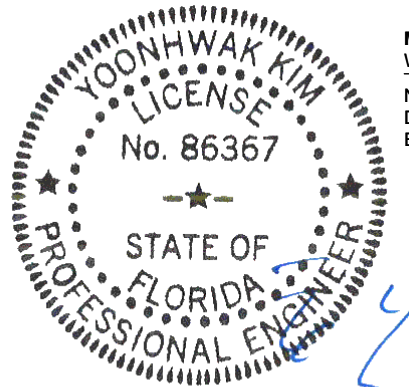

FL REG# 278, Yoonhwak Kim, FL PE #86367
 02/03/2022

****WARNING** READ AND FOLLOW ALL NOTES ON THIS DRAWING!**
****IMPORTANT** FURNISH THIS DRAWING TO ALL CONTRACTORS INCLUDING THE INSTALLERS**
 Trusses require extreme care in fabricating, handling, shipping, installing and bracing. Refer to and follow the latest edition of BCSI (Building Component Safety Information, by TPI and SBCA) for safety practices prior to performing these functions. Installers shall provide temporary bracing per BCSI. Unless noted otherwise, top chord shall have properly attached structural sheathing and bottom chord shall have a properly attached rigid ceiling. Locations shown for permanent lateral restraint of webs shall have bracing installed per BCSI sections B3, B7, or B10, as applicable. Apply plates to each face of truss and position as shown above and on the Joint Details, unless noted otherwise. Refer to drawings 160A-Z for standard plate positions. Refer to job's General Notes page for additional information.
 Alpine, a division of ITW Building Components Group Inc. shall not be responsible for any deviation from this drawing, any failure to build the truss in conformance with ANSI/TPI 1, or for handling, shipping, installation and bracing of trusses. A seal on this drawing or cover page listing this drawing, indicates acceptance of professional engineering responsibility solely for the design shown. The suitability and use of this drawing for any structure is the responsibility of the Building Designer per ANSI/TPI 1 Sec.2.
 For more information see these web sites: Alpine: alpineitw.com; TPI: tpinst.org; SBCA: sbcindustry.com; ICC: iccsafe.org; AWC: awc.org



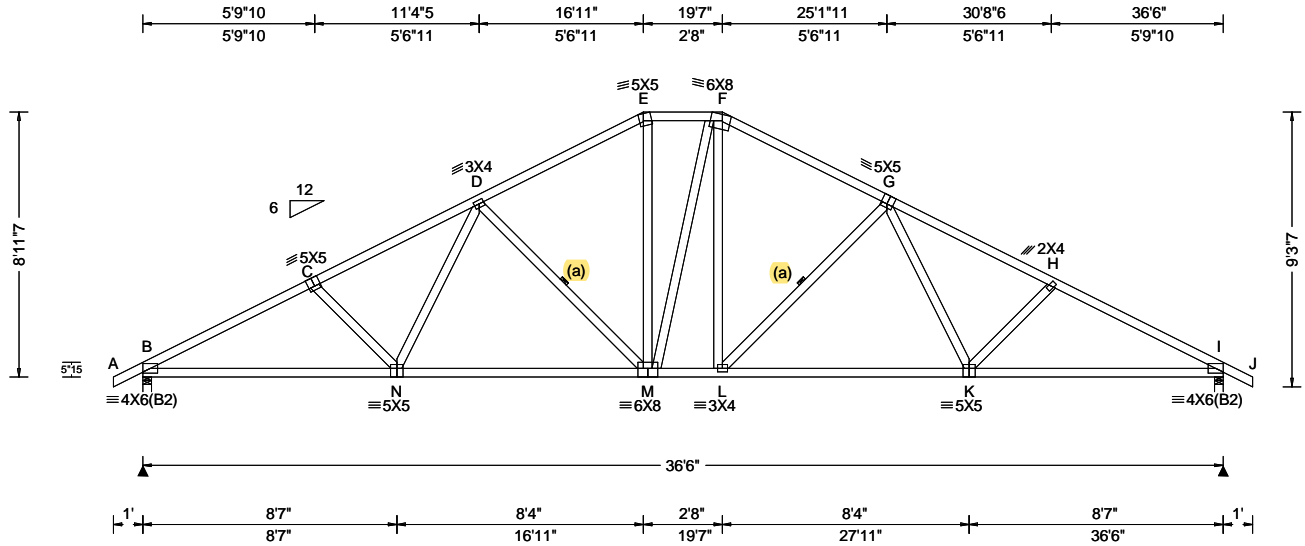

Loading Criteria (psf) TCLL: 20.00 TCCL: 10.00 BCCL: 0.00 BCDL: 10.00 Des Ld: 40.00 NCBCLL: 10.00 Soffit: 2.00 Load Duration: 1.25 Spacing: 24.0 "	Wind Criteria Wind Std: ASCE 7-16 Speed: 130 mph Enclosure: Closed Risk Category: II EXP: C Kzt: NA Mean Height: 15.00 ft TCCL: 5.0 psf BCDL: 5.0 psf MWFRS Parallel Dist: h to 2h C&C Dist a: 3.65 ft Loc. from endwall: not in 9.00 ft GCp: 0.18 Wind Duration: 1.60	Snow Criteria (Pg,Pf in PSF) Pg: NA Ct: NA CAT: NA Pf: NA Ce: NA Lu: NA Cs: NA Snow Duration: NA Building Code: FBC 7th Ed. 2020 Res. TPI Std: 2014 Rep Fac: Yes FT/RT:20(0)/10(0) Plate Type(s): WAVE	Defl/CSI Criteria PP Deflection in loc L/def L/# VERT(LL): 0.164 L 999 360 VERT(CL): 0.335 L 999 240 HORZ(LL): 0.075 K - - HORZ(TL): 0.152 K - - Creep Factor: 2.0 Max TC CSI: 0.727 Max BC CSI: 0.966 Max Web CSI: 0.230 VIEW Ver: 21.01.01A.0521.20	▲ Maximum Reactions (lbs) <table style="width:100%; border-collapse: collapse;"> <thead> <tr> <th rowspan="2">Loc</th> <th colspan="3">Gravity</th> <th colspan="3">Non-Gravity</th> </tr> <tr> <th>R+</th> <th>/R-</th> <th>/Rh</th> <th>/Rw</th> <th>/U</th> <th>/RL</th> </tr> </thead> <tbody> <tr> <td>B</td> <td>1570</td> <td>-</td> <td>-</td> <td>/937</td> <td>/33</td> <td>/250</td> </tr> <tr> <td>I</td> <td>1570</td> <td>-</td> <td>-</td> <td>/937</td> <td>/33</td> <td>-</td> </tr> </tbody> </table> <p>Wind reactions based on MWFRS B Brg Width = 3.5 Min Req = 1.9 I Brg Width = 3.5 Min Req = 1.9 Bearings B & I are a rigid surface. Members not listed have forces less than 375# Maximum Top Chord Forces Per Ply (lbs)</p> <table style="width:100%; border-collapse: collapse;"> <thead> <tr> <th>Chords</th> <th>Tens.Comp.</th> <th>Chords</th> <th>Tens. Comp.</th> </tr> </thead> <tbody> <tr> <td>B - C</td> <td>664 -2691</td> <td>F - G</td> <td>600 -1844</td> </tr> <tr> <td>C - D</td> <td>647 -2464</td> <td>G - H</td> <td>648 -2464</td> </tr> <tr> <td>D - E</td> <td>599 -1836</td> <td>H - I</td> <td>665 -2692</td> </tr> <tr> <td>E - F</td> <td>583 -1573</td> <td></td> <td></td> </tr> </tbody> </table> <p>Maximum Bot Chord Forces Per Ply (lbs)</p> <table style="width:100%; border-collapse: collapse;"> <thead> <tr> <th>Chords</th> <th>Tens.Comp.</th> <th>Chords</th> <th>Tens. Comp.</th> </tr> </thead> <tbody> <tr> <td>B - N</td> <td>2318 -515</td> <td>L - K</td> <td>1989 -389</td> </tr> <tr> <td>N - M</td> <td>1990 -401</td> <td>K - I</td> <td>2319 -505</td> </tr> <tr> <td>M - L</td> <td>1571 -230</td> <td></td> <td></td> </tr> </tbody> </table> <p>Maximum Web Forces Per Ply (lbs)</p> <table style="width:100%; border-collapse: collapse;"> <thead> <tr> <th>Webs</th> <th>Tens.Comp.</th> <th>Webs</th> <th>Tens. Comp.</th> </tr> </thead> <tbody> <tr> <td>N - D</td> <td>436 -21</td> <td>F - L</td> <td>542 -116</td> </tr> <tr> <td>D - M</td> <td>231 -605</td> <td>L - G</td> <td>229 -602</td> </tr> <tr> <td>E - M</td> <td>541 -140</td> <td>G - K</td> <td>434 -24</td> </tr> </tbody> </table>	Loc	Gravity			Non-Gravity			R+	/R-	/Rh	/Rw	/U	/RL	B	1570	-	-	/937	/33	/250	I	1570	-	-	/937	/33	-	Chords	Tens.Comp.	Chords	Tens. Comp.	B - C	664 -2691	F - G	600 -1844	C - D	647 -2464	G - H	648 -2464	D - E	599 -1836	H - I	665 -2692	E - F	583 -1573			Chords	Tens.Comp.	Chords	Tens. Comp.	B - N	2318 -515	L - K	1989 -389	N - M	1990 -401	K - I	2319 -505	M - L	1571 -230			Webs	Tens.Comp.	Webs	Tens. Comp.	N - D	436 -21	F - L	542 -116	D - M	231 -605	L - G	229 -602	E - M	541 -140	G - K	434 -24
Loc	Gravity			Non-Gravity																																																																															
	R+	/R-	/Rh	/Rw	/U	/RL																																																																													
B	1570	-	-	/937	/33	/250																																																																													
I	1570	-	-	/937	/33	-																																																																													
Chords	Tens.Comp.	Chords	Tens. Comp.																																																																																
B - C	664 -2691	F - G	600 -1844																																																																																
C - D	647 -2464	G - H	648 -2464																																																																																
D - E	599 -1836	H - I	665 -2692																																																																																
E - F	583 -1573																																																																																		
Chords	Tens.Comp.	Chords	Tens. Comp.																																																																																
B - N	2318 -515	L - K	1989 -389																																																																																
N - M	1990 -401	K - I	2319 -505																																																																																
M - L	1571 -230																																																																																		
Webs	Tens.Comp.	Webs	Tens. Comp.																																																																																
N - D	436 -21	F - L	542 -116																																																																																
D - M	231 -605	L - G	229 -602																																																																																
E - M	541 -140	G - K	434 -24																																																																																

Lumber

Top chord: 2x4 SP #2;
 Bot chord: 2x4 SP #2;
 Webs: 2x4 SP #3;

Bracing

(a) Continuous lateral restraint equally spaced on member.

Purlins

In lieu of structural panels use purlins to brace all flat TC @ 24" oc.

Wind

Wind loads based on MWFRS with additional C&C member design.
 Wind loading based on both gable and hip roof types.

Additional Notes

The overall height of this truss excluding overhang is 8-11-7.

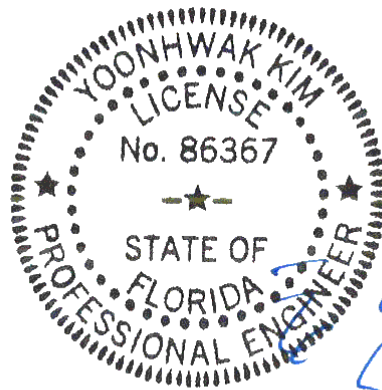

FL REG# 278, Yoonhwak Kim, FL PE #86367
 02/03/2022

****WARNING** READ AND FOLLOW ALL NOTES ON THIS DRAWING!**
****IMPORTANT** FURNISH THIS DRAWING TO ALL CONTRACTORS INCLUDING THE INSTALLERS**
 Trusses require extreme care in fabricating, handling, shipping, installing and bracing. Refer to and follow the latest edition of BCSI (Building Component Safety Information, by TPI and SBCA) for safety practices prior to performing these functions. Installers shall provide temporary bracing per BCSI. Unless noted otherwise, top chord shall have properly attached structural sheathing and bottom chord shall have a properly attached rigid ceiling. Locations shown for permanent lateral restraint of webs shall have bracing installed per BCSI sections B3, B7, or B10, as applicable. Apply plates to each face of truss and position as shown above and on the Joint Details, unless noted otherwise. Refer to drawings 160A-Z for standard plate positions. Refer to job's General Notes page for additional information.
 Alpine, a division of ITW Building Components Group Inc. shall not be responsible for any deviation from this drawing, any failure to build the truss in conformance with ANSI/TPI 1, or for handling, shipping, installation and bracing of trusses. A seal on this drawing or cover page listing this drawing, indicates acceptance of professional engineering responsibility solely for the design shown. The suitability and use of this drawing for any structure is the responsibility of the Building Designer per ANSI/TPI 1 Sec.2.
 For more information see these web sites: Alpine: alpineitw.com; TPI: tpinst.org; SBCA: sbcindustry.com; ICC: iccsafe.org; AWC: awc.org



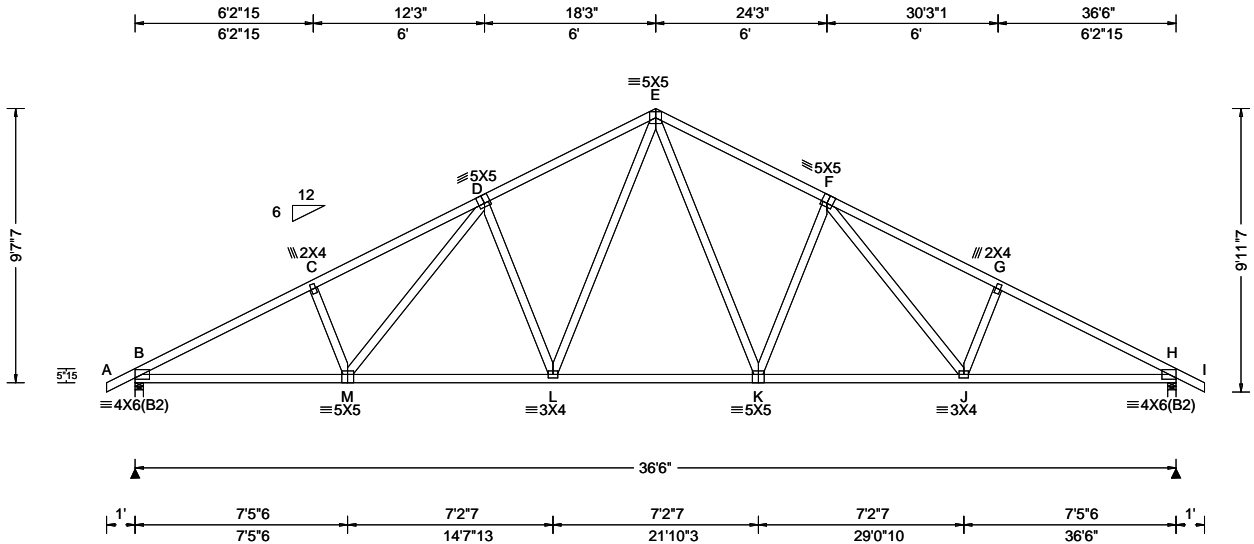

Loading Criteria (psf) TCLL: 20.00 TCDL: 10.00 BCLL: 0.00 BCDL: 10.00 Des Ld: 40.00 NCBCLL: 10.00 Soffit: 2.00 Load Duration: 1.25 Spacing: 24.0 "	Wind Criteria Wind Std: ASCE 7-16 Speed: 130 mph Enclosure: Closed Risk Category: II EXP: C Kzt: NA Mean Height: 15.00 ft TCDL: 5.0 psf BCDL: 5.0 psf MWFRS Parallel Dist: h to 2h C&C Dist a: 3.65 ft Loc. from endwall: not in 9.00 ft GCp: 0.18 Wind Duration: 1.60	Snow Criteria (Pg,Pf in PSF) Pg: NA Ct: NA CAT: NA Pf: NA Ce: NA Lu: NA Cs: NA Snow Duration: NA Building Code: FBC 7th Ed. 2020 Res. TPI Std: 2014 Rep Fac: Yes FT/RT:20(0)/10(0) Plate Type(s): WAVE	Defl/CSI Criteria PP Deflection in loc L/def L/# VERT(LL): 0.165 L 999 360 VERT(CL): 0.336 L 999 240 HORZ(LL): 0.070 J - - HORZ(TL): 0.143 J - - Creep Factor: 2.0 Max TC CSI: 0.727 Max BC CSI: 0.957 Max Web CSI: 0.499 VIEW Ver: 21.01.01A.0521.20	▲ Maximum Reactions (lbs) Gravity Non-Gravity Loc R+ / R- / Rh / Rw / U / RL B 1570 /- /- /937 /30 /268 H 1570 /- /- /937 /30 /- Wind reactions based on MWFRS B Brg Width = 3.5 Min Req = 1.9 H Brg Width = 3.5 Min Req = 1.9 Bearings B & H are a rigid surface. Members not listed have forces less than 375# Maximum Top Chord Forces Per Ply (lbs) Chords Tens.Comp. Chords Tens. Comp. B - C 588 -2688 E - F 594 -2016 C - D 635 -2548 F - G 634 -2548 D - E 594 -2016 G - H 587 -2688 Maximum Bot Chord Forces Per Ply (lbs) Chords Tens.Comp. Chords Tens. Comp. B - M 2313 -435 K - J 1931 -299 M - L 1931 -310 J - H 2314 -424 L - K 1463 -149 Maximum Web Forces Per Ply (lbs) Webs Tens.Comp. Webs Tens. Comp. M - D 462 -112 E - K 727 -184 D - L 258 -562 K - F 258 -563 L - E 729 -183 F - J 463 -111
--	--	--	--	--

Lumber

Top chord: 2x4 SP #2;
Bot chord: 2x4 SP #2;
Webs: 2x4 SP #3;

Wind

Wind loads based on MWFRS with additional C&C member design.
Wind loading based on both gable and hip roof types.

Additional Notes

The overall height of this truss excluding overhang is 9'-7.7".

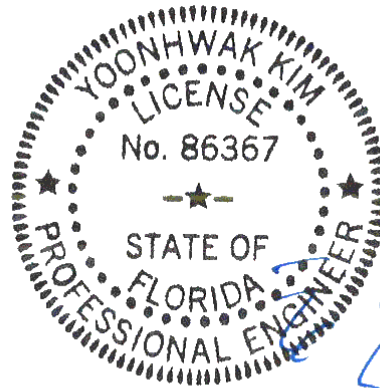

FL REG# 278, Yoonhwak Kim, FL PE #86367
02/03/2022

****WARNING** READ AND FOLLOW ALL NOTES ON THIS DRAWING!**
****IMPORTANT** FURNISH THIS DRAWING TO ALL CONTRACTORS INCLUDING THE INSTALLERS**
Trusses require extreme care in fabricating, handling, shipping, installing and bracing. Refer to and follow the latest edition of BCSI (Building Component Safety Information, by TPI and SBCA) for safety practices prior to performing these functions. Installers shall provide temporary bracing per BCSI. Unless noted otherwise, top chord shall have properly attached structural sheathing and bottom chord shall have a properly attached rigid ceiling. Locations shown for permanent lateral restraint of webs shall have bracing installed per BCSI sections B3, B7, or B10, as applicable. Apply plates to each face of truss and position as shown above and on the Joint Details, unless noted otherwise. Refer to drawings 160A-Z for standard plate positions. Refer to job's General Notes page for additional information.
Alpine, a division of ITW Building Components Group Inc. shall not be responsible for any deviation from this drawing, any failure to build the truss in conformance with ANSI/TPI 1, or for handling, shipping, installation and bracing of trusses. A seal on this drawing or cover page listing this drawing, indicates acceptance of professional engineering responsibility solely for the design shown. The suitability and use of this drawing for any structure is the responsibility of the Building Designer per ANSI/TPI 1 Sec.2.
For more information see these web sites: Alpine: alpineitw.com; TPI: tpinst.org; SBCA: sbcindustry.com; ICC: iccsafe.org; AWC: awc.org



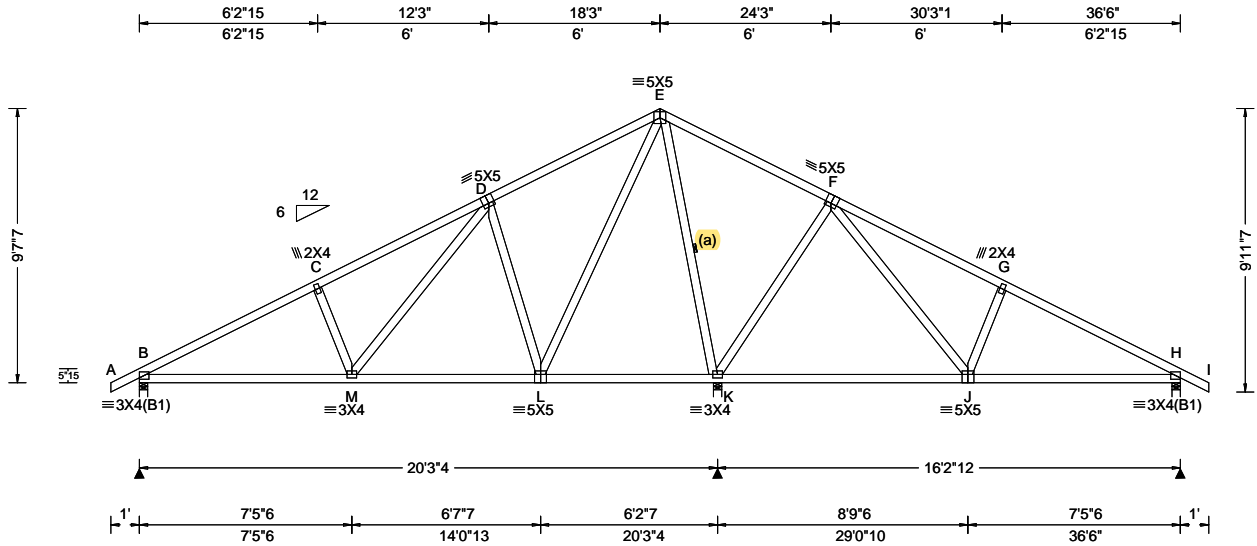

Loading Criteria (psf) TCLL: 20.00 TCDL: 10.00 BCLL: 0.00 BCDL: 10.00 Des Ld: 40.00 NCBCLL: 10.00 Soffit: 2.00 Load Duration: 1.25 Spacing: 24.0 "	Wind Criteria Wind Std: ASCE 7-16 Speed: 130 mph Enclosure: Closed Risk Category: II EXP: C Kzt: NA Mean Height: 15.00 ft TCDL: 5.0 psf BCDL: 5.0 psf MWFRS Parallel Dist: 0 to h/2 C&C Dist a: 3.65 ft Loc. from endwall: not in 4.50 ft GCp: 0.18 Wind Duration: 1.60	Snow Criteria (Pg,Pf in PSF) Pg: NA Ct: NA CAT: NA Pf: NA Ce: NA Lu: NA Cs: NA Snow Duration: NA Building Code: FBC 7th Ed. 2020 Res. TPI Std: 2014 Rep Fac: Yes FT/RT:20(0)/10(0) Plate Type(s): WAVE	Defl/CSI Criteria PP Deflection in loc L/def L/# VERT(LL): 0.039 M 999 360 VERT(CL): 0.077 M 999 240 HORZ(LL): 0.013 C - - HORZ(TL): 0.025 C - - Creep Factor: 2.0 Max TC CSI: 0.586 Max BC CSI: 0.563 Max Web CSI: 0.754 VIEW Ver: 21.01.01A.0521.20	▲ Maximum Reactions (lbs) Gravity Loc R+ / R- / Rh / Rw / U / RL Non-Gravity B 784 /- /- /477 /131 /268 K 2284 /- /- /1035 /324 /- H 548 /- /- /393 /95 /- Wind reactions based on MWFRS B Brg Width = 3.5 Min Req = 1.5 K Brg Width = 3.5 Min Req = 2.3 H Brg Width = 3.5 Min Req = 1.5 Bearings B, K, & H are a rigid surface. Members not listed have forces less than 375# Maximum Top Chord Forces Per Ply (lbs) Chords Tens.Comp. Chords Tens. Comp. B - C 221 -1080 F - G 183 -481 C - D 269 -943 G - H 135 -616 E - F 686 0 Maximum Bot Chord Forces Per Ply (lbs) Chords Tens.Comp. Chords Tens. Comp. B - M 891 -225 J - H 480 -57 M - L 411 -160 Maximum Web Forces Per Ply (lbs) Webs Tens.Comp. Webs Tens. Comp. M - D 608 -129 E - K 268 -1406 D - L 293 -658 K - F 287 -693 L - E 943 -245 F - J 699 -121
--	---	--	--	--

Lumber

Top chord: 2x4 SP #2;
Bot chord: 2x4 SP #2;
Webs: 2x4 SP #3;

Bracing

(a) Continuous lateral restraint equally spaced on member.

Loading

Truss passed check for 20 psf additional bottom chord live load in areas with 42"-high x 24"-wide clearance.

Wind

Wind loads based on MWFRS with additional C&C member design.
Wind loading based on both gable and hip roof types.

Additional Notes

The overall height of this truss excluding overhang is 9-7.7.

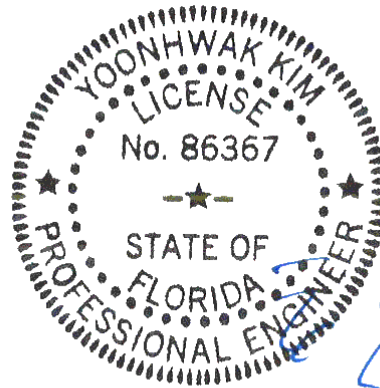

FL REG# 278, Yoonhwak Kim, FL PE #86367
02/03/2022

****WARNING** READ AND FOLLOW ALL NOTES ON THIS DRAWING!**
****IMPORTANT** FURNISH THIS DRAWING TO ALL CONTRACTORS INCLUDING THE INSTALLERS**
Trusses require extreme care in fabricating, handling, shipping, installing and bracing. Refer to and follow the latest edition of BCSI (Building Component Safety Information, by TPI and SBCA) for safety practices prior to performing these functions. Installers shall provide temporary bracing per BCSI. Unless noted otherwise, top chord shall have properly attached structural sheathing and bottom chord shall have a properly attached rigid ceiling. Locations shown for permanent lateral restraint of webs shall have bracing installed per BCSI sections B3, B7, or B10, as applicable. Apply plates to each face of truss and position as shown above and on the Joint Details, unless noted otherwise. Refer to drawings 160A-Z for standard plate positions. Refer to job's General Notes page for additional information.
Alpine, a division of ITW Building Components Group Inc. shall not be responsible for any deviation from this drawing, any failure to build the truss in conformance with ANSI/TPI 1, or for handling, shipping, installation and bracing of trusses. A seal on this drawing or cover page listing this drawing, indicates acceptance of professional engineering responsibility solely for the design shown. The suitability and use of this drawing for any structure is the responsibility of the Building Designer per ANSI/TPI 1 Sec.2.
For more information see these web sites: Alpine: alpineitw.com; TPI: tpinst.org; SBCA: sbcindustry.com; ICC: iccsafe.org; AWC: awc.org



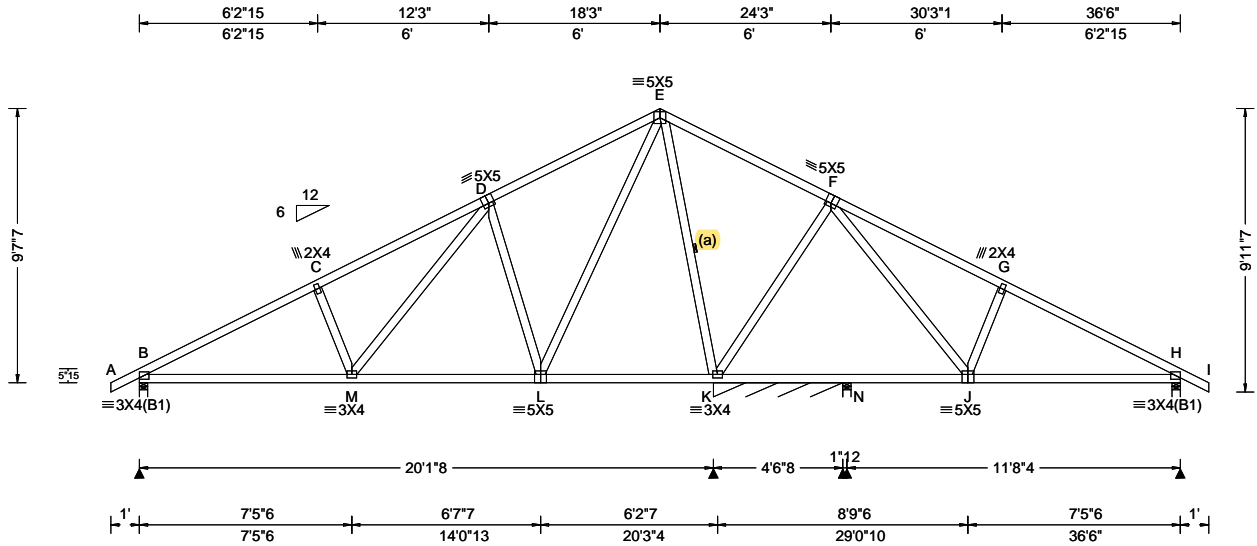

Loading Criteria (psf) TCCL: 20.00 TCDL: 10.00 BCCL: 0.00 BCDL: 10.00 Des Ld: 40.00 NCBCLL: 10.00 Soffit: 2.00 Load Duration: 1.25 Spacing: 24.0 "	Wind Criteria Wind Std: ASCE 7-16 Speed: 130 mph Enclosure: Closed Risk Category: II EXP: C Kzt: NA Mean Height: 15.00 ft TCDL: 5.0 psf BCDL: 5.0 psf MWFRS Parallel Dist: 0 to h/2 C&C Dist a: 3.65 ft Loc. from endwall: not in 4.50 ft GCp: 0.18 Wind Duration: 1.60	Snow Criteria (Pg,Pf in PSF) Pg: NA Ct: NA CAT: NA Pf: NA Ce: NA Lu: NA Cs: NA Snow Duration: NA Building Code: FBC 7th Ed. 2020 Res. TPI Std: 2014 Rep Fac: Yes FT/RT:20(0)/10(0) Plate Type(s): WAVE	Defl/CSI Criteria PP Deflection in loc L/defl L/# VERT(LL): 0.032 M 999 360 VERT(CL): 0.071 M 999 240 HORZ(LL): 0.011 C - - HORZ(TL): 0.023 C - - Creep Factor: 2.0 Max TC CSI: 0.585 Max BC CSI: 0.485 Max Web CSI: 0.692 VIEW Ver: 21.01.01A.0521.20	▲ Maximum Reactions (lbs), or *=PLF <table style="width:100%; border-collapse: collapse;"> <thead> <tr> <th rowspan="2">Loc</th> <th colspan="3">Gravity</th> <th colspan="3">Non-Gravity</th> </tr> <tr> <th>R+</th> <th>/R-</th> <th>/Rh</th> <th>/Rw</th> <th>/U</th> <th>/RL</th> </tr> </thead> <tbody> <tr> <td>B</td> <td>773</td> <td>-</td> <td>-</td> <td>/488</td> <td>/125</td> <td>/268</td> </tr> <tr> <td>K*</td> <td>408</td> <td>-</td> <td>-</td> <td>/213</td> <td>/80</td> <td>-</td> </tr> <tr> <td>N</td> <td>128</td> <td>-</td> <td>-</td> <td>/68</td> <td>-</td> <td>-</td> </tr> <tr> <td>H</td> <td>551</td> <td>-</td> <td>-</td> <td>/390</td> <td>/96</td> <td>-</td> </tr> </tbody> </table> <p>Wind reactions based on MWFRS</p> <table style="width:100%; border-collapse: collapse;"> <tr> <td>B</td> <td>Brg Width = 3.5</td> <td>Min Req = 1.5</td> </tr> <tr> <td>K</td> <td>Brg Width = 54.5</td> <td>Min Req = -</td> </tr> <tr> <td>N</td> <td>Brg Width = 3.5</td> <td>Min Req = 1.5</td> </tr> <tr> <td>H</td> <td>Brg Width = 3.5</td> <td>Min Req = 1.5</td> </tr> </table> <p>Bearings B, K, N, & H are a rigid surface. Members not listed have forces less than 375#</p>	Loc	Gravity			Non-Gravity			R+	/R-	/Rh	/Rw	/U	/RL	B	773	-	-	/488	/125	/268	K*	408	-	-	/213	/80	-	N	128	-	-	/68	-	-	H	551	-	-	/390	/96	-	B	Brg Width = 3.5	Min Req = 1.5	K	Brg Width = 54.5	Min Req = -	N	Brg Width = 3.5	Min Req = 1.5	H	Brg Width = 3.5	Min Req = 1.5
Loc	Gravity			Non-Gravity																																																					
	R+	/R-	/Rh	/Rw	/U	/RL																																																			
B	773	-	-	/488	/125	/268																																																			
K*	408	-	-	/213	/80	-																																																			
N	128	-	-	/68	-	-																																																			
H	551	-	-	/390	/96	-																																																			
B	Brg Width = 3.5	Min Req = 1.5																																																							
K	Brg Width = 54.5	Min Req = -																																																							
N	Brg Width = 3.5	Min Req = 1.5																																																							
H	Brg Width = 3.5	Min Req = 1.5																																																							

Lumber
 Top chord: 2x4 SP #2;
 Bot chord: 2x4 SP #2;
 Webs: 2x4 SP #3;

Bracing
 (a) Continuous lateral restraint equally spaced on member.

Wind
 Wind loads based on MWFRS with additional C&C member design.
 Wind loading based on both gable and hip roof types.

Additional Notes
 The overall height of this truss excluding overhang is 9'-7.7\"/>

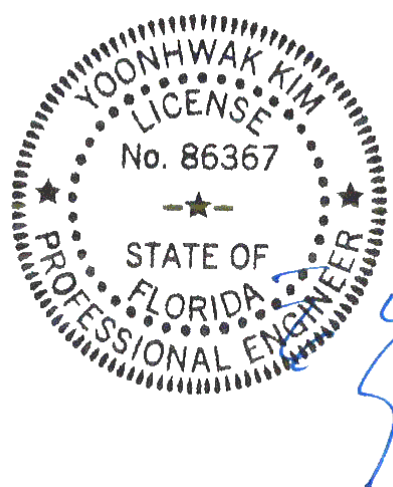

FL REG# 278, Yoonhwak Kim, FL PE #86367
 02/03/2022

Maximum Top Chord Forces Per Ply (lbs)

Chords	Tens.Comp.	Chords	Tens. Comp.
B - C	209 -1051	F - G	193 -460
C - D	256 -915	G - H	144 -594
E - F	578 0		

Maximum Bot Chord Forces Per Ply (lbs)

Chords	Tens.Comp.	Chords	Tens. Comp.
B - M	866 -213	J - H	463 -64
M - L	410 -147		

Maximum Web Forces Per Ply (lbs)

Webs	Tens.Comp.	Webs	Tens. Comp.
M - D	567 -132	E - K	275 -1229
D - L	294 -639	K - F	298 -635
L - E	808 -239	F - J	590 -145

****WARNING** READ AND FOLLOW ALL NOTES ON THIS DRAWING!**
****IMPORTANT** FURNISH THIS DRAWING TO ALL CONTRACTORS INCLUDING THE INSTALLERS**
 Trusses require extreme care in fabricating, handling, shipping, installing and bracing. Refer to and follow the latest edition of BCSI (Building Component Safety Information, by TPI and SBCA) for safety practices prior to performing these functions. Installers shall provide temporary bracing per BCSI. Unless noted otherwise, top chord shall have properly attached structural sheathing and bottom chord shall have a properly attached rigid ceiling. Locations shown for permanent lateral restraint of webs shall have bracing installed per BCSI sections B3, B7, or B10, as applicable. Apply plates to each face of truss and position as shown above and on the Joint Details, unless noted otherwise. Refer to drawings 160A-Z for standard plate positions. Refer to job's General Notes page for additional information.
 Alpine, a division of ITW Building Components Group Inc. shall not be responsible for any deviation from this drawing, any failure to build the truss in conformance with ANSI/TPI 1, or for handling, shipping, installation and bracing of trusses. A seal on this drawing or cover page listing this drawing, indicates acceptance of professional engineering responsibility solely for the design shown. The suitability and use of this drawing for any structure is the responsibility of the Building Designer per ANSI/TPI 1 Sec.2.
 For more information see these web sites: Alpine: alpineitw.com; TPI: tpinst.org; SBCA: sbcindustry.com; ICC: iccsafe.org; AWC: awc.org



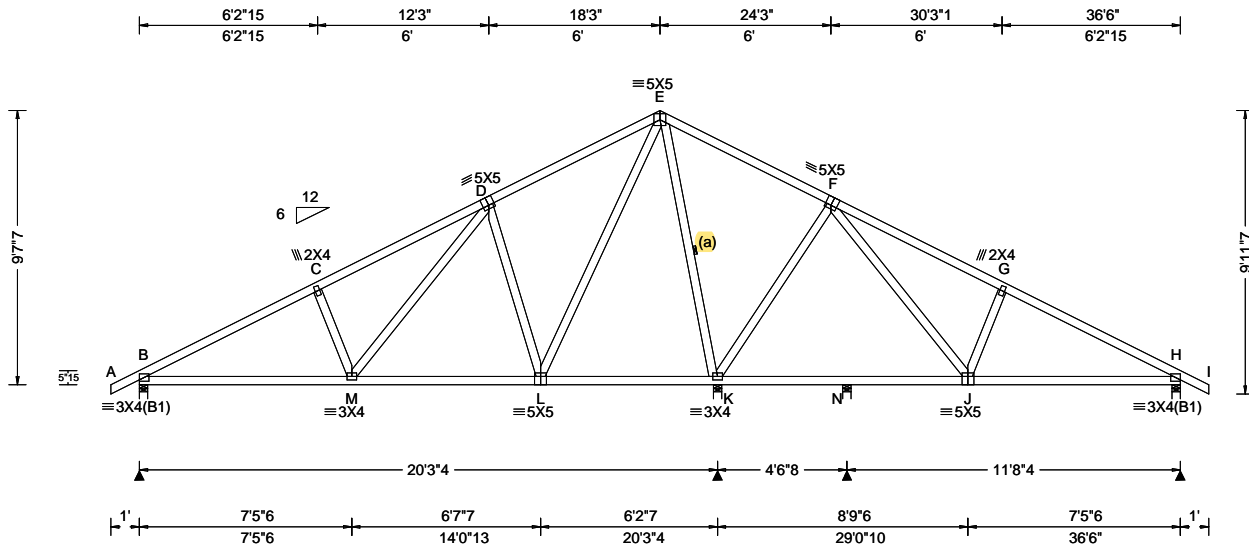

Loading Criteria (psf) TCLL: 20.00 TCDL: 10.00 BCLL: 0.00 BCDL: 10.00 Des Ld: 40.00 NCBCLL: 10.00 Soffit: 2.00 Load Duration: 1.25 Spacing: 24.0 "	Wind Criteria Wind Std: ASCE 7-16 Speed: 130 mph Enclosure: Closed Risk Category: II EXP: C Kzt: NA Mean Height: 15.00 ft TCDL: 5.0 psf BCDL: 5.0 psf MWFRS Parallel Dist: 0 to h/2 C&C Dist a: 3.65 ft Loc. from endwall: Any GCp: 0.18 Wind Duration: 1.60	Snow Criteria (Pg,Pf in PSF) Pg: NA Ct: NA CAT: NA Pf: NA Ce: NA Lu: NA Cs: NA Snow Duration: NA Building Code: FBC 7th Ed. 2020 Res. TPI Std: 2014 Rep Fac: Yes FT/RT:20(0)/10(0) Plate Type(s): WAVE	Defl/CSI Criteria PP Deflection in loc L/def L/# VERT(LL): 0.032 M 999 360 VERT(CL): 0.071 M 999 240 HORZ(LL): 0.011 C - - HORZ(TL): 0.023 C - - Creep Factor: 2.0 Max TC CSI: 0.585 Max BC CSI: 0.485 Max Web CSI: 0.863 VIEW Ver: 21.01.01A.0521.20	▲ Maximum Reactions (lbs) Gravity Non-Gravity Loc R+ / R- / Rh / Rw / U / RL B 772 /- /- /488 /125 /268 K 1853 /- /- /967 /362 /- N 128 /- /- /68 /- /- H 558 /- /- /390 /96 /- Wind reactions based on MWFRS B Brg Width = 3.5 Min Req = 1.5 K Brg Width = 3.5 Min Req = 1.8 N Brg Width = 3.5 Min Req = 1.5 H Brg Width = 3.5 Min Req = 1.5 Bearings B, K, N, & H are a rigid surface. Members not listed have forces less than 375#
--	--	--	--	--

Lumber
Top chord: 2x4 SP #2;
Bot chord: 2x4 SP #2;
Webs: 2x4 SP #3;

Bracing
(a) Continuous lateral restraint equally spaced on member.

Wind
Wind loads based on MWFRS with additional C&C member design.
Wind loading based on both gable and hip roof types.

Additional Notes
The overall height of this truss excluding overhang is 9'-7".

Maximum Top Chord Forces Per Ply (lbs)

Chords	Tens.Comp.	Chords	Tens. Comp.
B - C	392 -1049	F - G	279 -470
C - D	450 -912	G - H	222 -605
E - F	578 -14		

Maximum Bot Chord Forces Per Ply (lbs)

Chords	Tens.Comp.	Chords	Tens. Comp.
B - M	864 -237	K - J	376 -349
M - L	407 -147	J - H	472 -76

Maximum Web Forces Per Ply (lbs)

Webs	Tens.Comp.	Webs	Tens. Comp.
M - D	567 -246	E - K	510 -1229
D - L	474 -639	K - F	478 -635
L - E	808 -427	F - J	590 -264

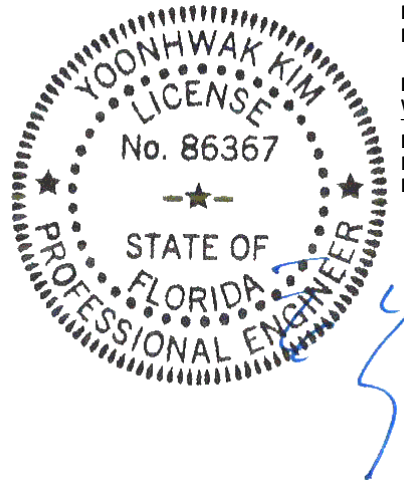

FL REG# 278, Yoonhwak Kim, FL PE #86367
02/03/2022

****WARNING** READ AND FOLLOW ALL NOTES ON THIS DRAWING!**
****IMPORTANT** FURNISH THIS DRAWING TO ALL CONTRACTORS INCLUDING THE INSTALLERS**
Trusses require extreme care in fabricating, handling, shipping, installing and bracing. Refer to and follow the latest edition of BCSI (Building Component Safety Information, by TPI and SBCA) for safety practices prior to performing these functions. Installers shall provide temporary bracing per BCSI. Unless noted otherwise, top chord shall have properly attached structural sheathing and bottom chord shall have a properly attached rigid ceiling. Locations shown for permanent lateral restraint of webs shall have bracing installed per BCSI sections B3, B7, or B10, as applicable. Apply plates to each face of truss and position as shown above and on the Joint Details, unless noted otherwise. Refer to drawings 160A-Z for standard plate positions. Refer to job's General Notes page for additional information.
Alpine, a division of ITW Building Components Group Inc. shall not be responsible for any deviation from this drawing, any failure to build the truss in conformance with ANSI/TPI 1, or for handling, shipping, installation and bracing of trusses. A seal on this drawing or cover page listing this drawing, indicates acceptance of professional engineering responsibility solely for the design shown. The suitability and use of this drawing for any structure is the responsibility of the Building Designer per ANSI/TPI 1 Sec.2.
For more information see these web sites: Alpine: alpineitw.com; TPI: tpinst.org; SBCA: sbcindustry.com; ICC: iccsafe.org; AWC: awc.org



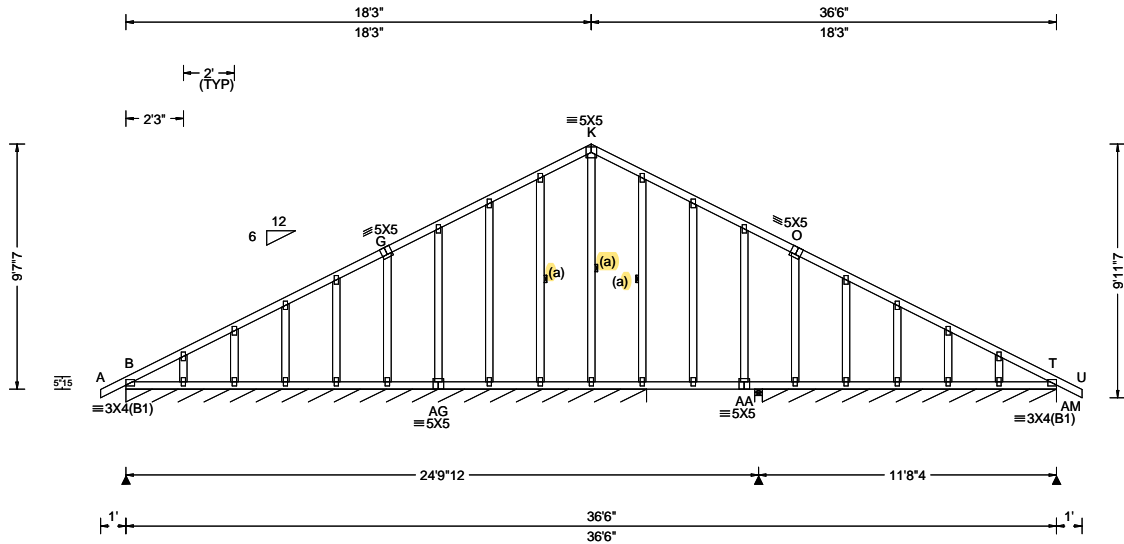

Loading Criteria (psf)	Wind Criteria	Snow Criteria (Pg, Pf in PSF)	Defl/CSI Criteria	▲ Maximum Reactions (lbs), or *=PLF
TCLL: 20.00 TCDL: 10.00 BCLL: 0.00 BCDL: 10.00 Des Ld: 40.00 NCBCLL: 10.00 Soffit: 2.00 Load Duration: 1.25 Spacing: 24.0 "	Wind Std: ASCE 7-16 Speed: 130 mph Enclosure: Closed Risk Category: II EXP: C Kzt: NA Mean Height: 15.00 ft TCDL: 5.0 psf BCDL: 5.0 psf MWFRS Parallel Dist: 0 to h/2 C&C Dist a: 3.65 ft Loc. from endwall: Any GCpi: 0.18 Wind Duration: 1.60	Pg: NA Ct: NA CAT: NA Pf: NA Ce: NA Lu: NA Cs: NA Snow Duration: NA Building Code: FBC 7th Ed. 2020 Res. TPI Std: 2014 Rep Fac: Yes FT/RT:20(0)/10(0) Plate Type(s): WAVE	PP Deflection in loc L/def L/# VERT(LL): 0.013 M 999 360 VERT(CL): 0.026 M 999 240 HORZ(LL): -0.006 M - - HORZ(TL): 0.013 M - - Creep Factor: 2.0 Max TC CSI: 0.162 Max BC CSI: 0.179 Max Web CSI: 0.128 VIEW Ver: 21.01.01A.0521.20	Gravity Non-Gravity Loc R+ / R- / Rh / Rw / U / RL B* 95 /- /- /59 /13 /13 AA 290 /- /- /213 /81 /- AM*82 /- /- /54 /18 /- Wind reactions based on MWFRS B Brg Width = 245 Min Req = - AA Brg Width = 3.5 Min Req = 1.5 AM Brg Width = 138 Min Req = - Bearings B, AA, & AA are a rigid surface. Members not listed have forces less than 375#

Lumber

Top chord: 2x4 SP #2;
Bot chord: 2x4 SP #2;
Webs: 2x4 SP #3;

Bracing

(a) Continuous lateral restraint equally spaced on member.

Plating Notes

All plates are 2X4 except as noted.

Loading

Gable end supports 8" max rake overhang. Top chord must not be cut or notched.

Wind

Wind loads based on MWFRS with additional C&C member design.
Wind loading based on both gable and hip roof types.

Additional Notes

See DWGS A14015ENC160118 & GBLLETIN0118 for gable wind bracing and other requirements.
The overall height of this truss excluding overhang is 9-7-7.

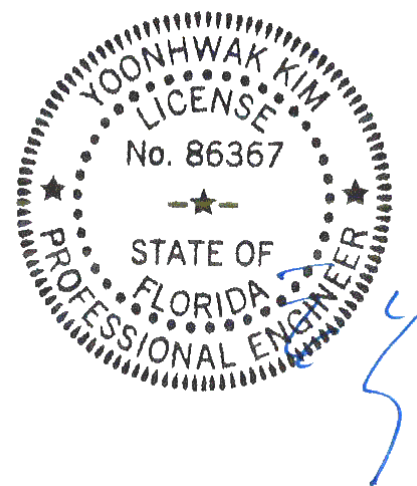

FL REG# 278, Yoonhwak Kim, FL PE #86367
02/03/2022

****WARNING** READ AND FOLLOW ALL NOTES ON THIS DRAWING!**
****IMPORTANT** FURNISH THIS DRAWING TO ALL CONTRACTORS INCLUDING THE INSTALLERS**
Trusses require extreme care in fabricating, handling, shipping, installing and bracing. Refer to and follow the latest edition of BCSI (Building Component Safety Information, by TPI and SBCA) for safety practices prior to performing these functions. Installers shall provide temporary bracing per BCSI. Unless noted otherwise, top chord shall have properly attached structural sheathing and bottom chord shall have a properly attached rigid ceiling. Locations shown for permanent lateral restraint of webs shall have bracing installed per BCSI sections B3, B7, or B10, as applicable. Apply plates to each face of truss and position as shown above and on the Joint Details, unless noted otherwise. Refer to drawings 160A-Z for standard plate positions. Refer to job's General Notes page for additional information.
Alpine, a division of ITW Building Components Group Inc. shall not be responsible for any deviation from this drawing, any failure to build the truss in conformance with ANSI/TPI 1, or for handling, shipping, installation and bracing of trusses. A seal on this drawing or cover page listing this drawing, indicates acceptance of professional engineering responsibility solely for the design shown. The suitability and use of this drawing for any structure is the responsibility of the Building Designer per ANSI/TPI 1 Sec.2.
For more information see these web sites: Alpine: alpineitw.com; TPI: tpinst.org; SBCA: sbcindustry.com; ICC: iccsafe.org; AWC: awc.org



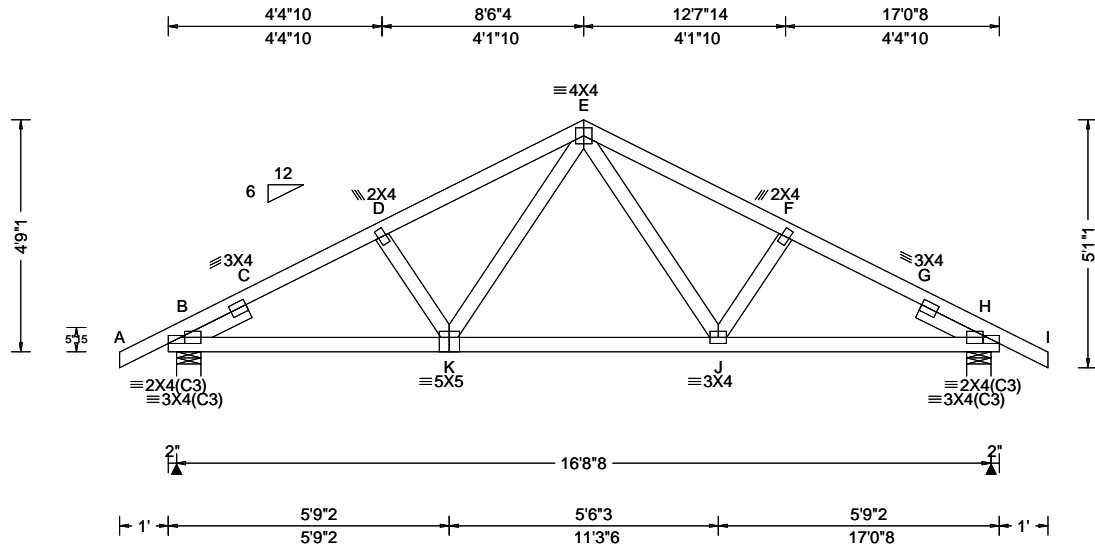

Loading Criteria (psf) TCLL: 20.00 TCDL: 10.00 BCLL: 0.00 BCDL: 10.00 Des Ld: 40.00 NCBCLL: 10.00 Soffit: 2.00 Load Duration: 1.25 Spacing: 24.0 "	Wind Criteria Wind Std: ASCE 7-16 Speed: 130 mph Enclosure: Closed Risk Category: II EXP: C Kzt: NA Mean Height: 15.00 ft TCDL: 5.0 psf BCDL: 5.0 psf MWFRS Parallel Dist: 0 to h/2 C&C Dist a: 3.00 ft Loc. from endwall: Any GCpi: 0.18 Wind Duration: 1.60	Snow Criteria (Pg,Pf in PSF) Pg: NA Ct: NA CAT: NA Pf: NA Ce: NA Lu: NA Cs: NA Snow Duration: NA Building Code: FBC 7th Ed. 2020 Res. TPI Std: 2014 Rep Fac: Yes FT/RT:20(0)/10(0) Plate Type(s): WAVE	Defl/CSI Criteria PP Deflection in loc L/def L/# VERT(LL): 0.025 J 999 360 VERT(CL): 0.050 J 999 240 HORZ(LL): 0.010 G - - HORZ(TL): 0.020 G - - Creep Factor: 2.0 Max TC CSI: 0.191 Max BC CSI: 0.314 Max Web CSI: 0.229 VIEW Ver: 21.01.01A.0521.20	▲ Maximum Reactions (lbs) Gravity Non-Gravity Loc R+ / R- / Rh / Rw / U / RL B 769 - / - / - /466 /135 /135 H 769 - / - / - /466 /135 /- Wind reactions based on MWFRS B Brg Width = 6.0 Min Req = 1.5 H Brg Width = 6.0 Min Req = 1.5 Bearings B & H are a rigid surface. Members not listed have forces less than 375# Maximum Top Chord Forces Per Ply (lbs) Chords Tens.Comp. Chords Tens. Comp. B - C 605 -1148 E - F 532 -889 C - D 530 -982 F - G 530 -983 D - E 533 -889 G - H 602 -1147 Maximum Bot Chord Forces Per Ply (lbs) Chords Tens.Comp. Chords Tens. Comp. B - K 836 -373 J - H 836 -359 K - J 605 -179
--	---	--	--	--

Lumber

Top chord: 2x4 SP #2;
Bot chord: 2x4 SP #2;
Webs: 2x4 SP #3;
Lt Slider: 2x4 SP #3; block length = 1.500'
Rt Slider: 2x4 SP #3; block length = 1.500'

Wind

Wind loads based on MWFRS with additional C&C member design.
Left and right cantilevers are exposed to wind
Wind loading based on both gable and hip roof types.

Additional Notes

The overall height of this truss excluding overhang is 4-9-1.

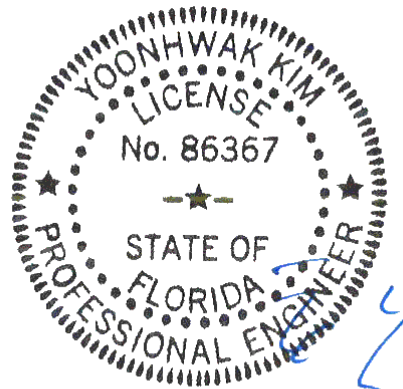

FL REG# 278, Yoonhwak Kim, FL PE #86367
02/03/2022

****WARNING** READ AND FOLLOW ALL NOTES ON THIS DRAWING!**
****IMPORTANT** FURNISH THIS DRAWING TO ALL CONTRACTORS INCLUDING THE INSTALLERS**
Trusses require extreme care in fabricating, handling, shipping, installing and bracing. Refer to and follow the latest edition of BCSI (Building Component Safety Information, by TPI and SBCA) for safety practices prior to performing these functions. Installers shall provide temporary bracing per BCSI. Unless noted otherwise, top chord shall have properly attached structural sheathing and bottom chord shall have a properly attached rigid ceiling. Locations shown for permanent lateral restraint of webs shall have bracing installed per BCSI sections B3, B7, or B10, as applicable. Apply plates to each face of truss and position as shown above and on the Joint Details, unless noted otherwise. Refer to drawings 160A-Z for standard plate positions. Refer to job's General Notes page for additional information.
Alpine, a division of ITW Building Components Group Inc. shall not be responsible for any deviation from this drawing, any failure to build the truss in conformance with ANSI/TPI 1, or for handling, shipping, installation and bracing of trusses. A seal on this drawing or cover page listing this drawing, indicates acceptance of professional engineering responsibility solely for the design shown. The suitability and use of this drawing for any structure is the responsibility of the Building Designer per ANSI/TPI 1 Sec.2.
For more information see these web sites: Alpine: alpineitw.com; TPI: tpinst.org; SBCA: sbcindustry.com; ICC: iccsafe.org; AWC: awc.org



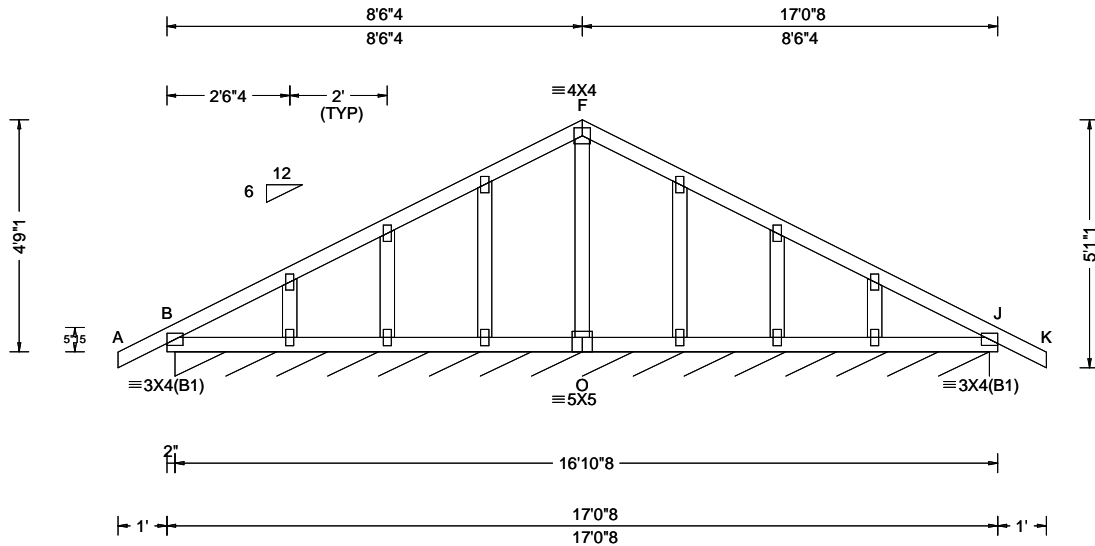

Loading Criteria (psf) TCLL: 20.00 TCDL: 10.00 BCLL: 0.00 BCDL: 10.00 Des Ld: 40.00 NCBCLL: 10.00 Soffit: 2.00 Load Duration: 1.25 Spacing: 24.0 "	Wind Criteria Wind Std: ASCE 7-16 Speed: 130 mph Enclosure: Closed Risk Category: II EXP: C Kzt: NA Mean Height: 15.00 ft TCDL: 5.0 psf BCDL: 5.0 psf MWFRS Parallel Dist: 0 to h/2 C&C Dist a: 3.00 ft Loc. from endwall: Any GCpi: 0.18 Wind Duration: 1.60	Snow Criteria (Pg,Pf in PSF) Pg: NA Ct: NA CAT: NA Pf: NA Ce: NA Lu: NA Cs: NA Snow Duration: NA Building Code: FBC 7th Ed. 2020 Res. TPI Std: 2014 Rep Fac: Yes FT/RT:20(0)/10(0) Plate Type(s): WAVE	Defl/CSI Criteria PP Deflection in loc L/def L/# VERT(LL): 0.001 R 999 360 VERT(CL): 0.001 R 999 240 HORZ(LL): -0.001 E - - HORZ(TL): 0.001 E - - Creep Factor: 2.0 Max TC CSI: 0.069 Max BC CSI: 0.038 Max Web CSI: 0.052 VIEW Ver: 21.01.01A.0521.20	▲ Maximum Reactions (lbs), or *=PLF Gravity Non-Gravity Loc R+ / R- / Rh / Rw / U / RL B* 92 /- /- /47 /16 /8 Wind reactions based on MWFRS B Brg Width = 200 Min Req = - Bearing B is a rigid surface. Members not listed have forces less than 375#
--	---	--	---	---

Lumber

Top chord: 2x4 SP #2;
Bot chord: 2x4 SP #2;
Webs: 2x4 SP #3;

Plating Notes

All plates are 2X4 except as noted.

Wind

Wind loads based on MWFRS with additional C&C member design.
Left and right cantilevers are exposed to wind
Wind loading based on both gable and hip roof types.

Additional Notes

See DWGS A14015ENC160118 & GBLLETIN0118 for gable wind bracing and other requirements.
The overall height of this truss excluding overhang is 4-9-1.
Truss designed to support 8" maximum gable end overhang.

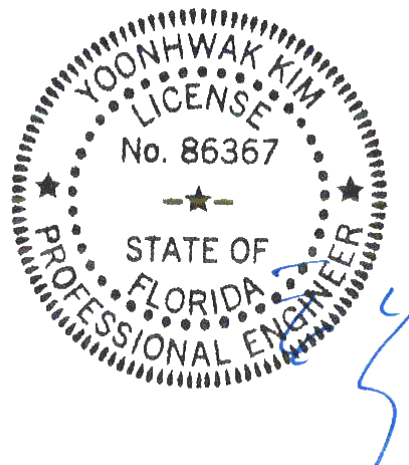

FL REG# 278, Yoonhwak Kim, FL PE #86367
02/03/2022

****WARNING** READ AND FOLLOW ALL NOTES ON THIS DRAWING!**
****IMPORTANT** FURNISH THIS DRAWING TO ALL CONTRACTORS INCLUDING THE INSTALLERS**
Trusses require extreme care in fabricating, handling, shipping, installing and bracing. Refer to and follow the latest edition of BCSI (Building Component Safety Information, by TPI and SBCA) for safety practices prior to performing these functions. Installers shall provide temporary bracing per BCSI. Unless noted otherwise, top chord shall have properly attached structural sheathing and bottom chord shall have a properly attached rigid ceiling. Locations shown for permanent lateral restraint of webs shall have bracing installed per BCSI sections B3, B7, or B10, as applicable. Apply plates to each face of truss and position as shown above and on the Joint Details, unless noted otherwise. Refer to drawings 160A-Z for standard plate positions. Refer to job's General Notes page for additional information.
Alpine, a division of ITW Building Components Group Inc. shall not be responsible for any deviation from this drawing, any failure to build the truss in conformance with ANSI/TPI 1, or for handling, shipping, installation and bracing of trusses. A seal on this drawing or cover page listing this drawing, indicates acceptance of professional engineering responsibility solely for the design shown. The suitability and use of this drawing for any structure is the responsibility of the Building Designer per ANSI/TPI 1 Sec.2.
For more information see these web sites: Alpine: alpineitw.com; TPI: tpinst.org; SBCA: sbcindustry.com; ICC: iccsafe.org; AWC: awc.org



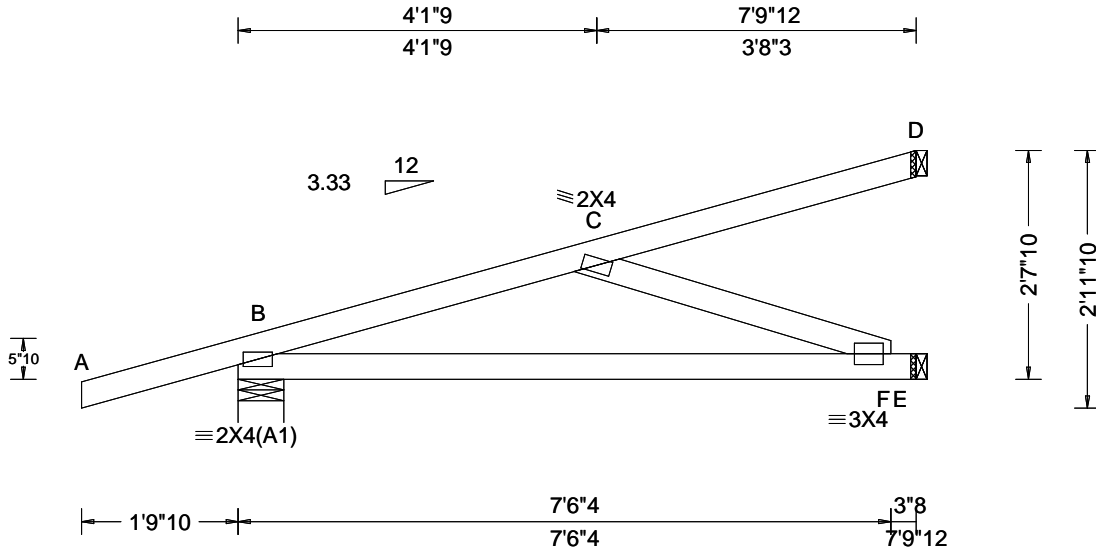

Loading Criteria (psf) TCLL: 20.00 TCDL: 10.00 BCLL: 0.00 BCDL: 10.00 Des Ld: 40.00 NCBCLL: 10.00 Soffit: 2.00 Load Duration: 1.25 Spacing: 24.0 "	Wind Criteria Wind Std: ASCE 7-16 Speed: 130 mph Enclosure: Closed Risk Category: II EXP: C Kzt: NA Mean Height: 15.00 ft TCDL: 5.0 psf BCDL: 5.0 psf MWFRS Parallel Dist: 0 to h/2 C&C Dist a: 3.00 ft Loc. from endwall: Any GCp: 0.18 Wind Duration: 1.60	Snow Criteria (Pg,Pf in PSF) Pg: NA Ct: NA CAT: NA Pf: NA Ce: NA Lu: NA Cs: NA Snow Duration: NA Building Code: FBC 7th Ed. 2020 Res. TPI Std: 2014 Rep Fac: Varies by Ld Case FT/RT:20(0)/10(0) Plate Type(s): WAVE	Defl/CSI Criteria PP Deflection in loc L/def L/# VERT(LL): 0.014 F 999 360 VERT(CL): 0.032 F 999 240 HORZ(LL): 0.003 C - - HORZ(TL): 0.009 F - - Creep Factor: 2.0 Max TC CSI: 0.217 Max BC CSI: 0.670 Max Web CSI: 0.208 VIEW Ver: 21.01.01A.0521.20	▲ Maximum Reactions (lbs) Gravity Loc R+ / R- / Rh / Rw / U / RL Non-Gravity B 293 /- /- /- /60 /- E 206 /- /- /- /25 /- D 38 /- /- /- /19 /- Wind reactions based on MWFRS B Brg Width = 6.3 Min Req = 1.5 E Brg Width = 1.5 Min Req = - D Brg Width = 1.5 Min Req = - Bearing B is a rigid surface. Members not listed have forces less than 375#
--	--	--	--	--

Lumber

Top chord: 2x4 SP #2;
Bot chord: 2x4 SP #2;
Webs: 2x4 SP #3;

Special Loads

----(Lumber Dur.Fac.=1.25 / Plate Dur.Fac.=1.25)
TC: From -0 plf at -1.80 to 61 plf at 0.00
TC: From 2 plf at 0.00 to 2 plf at 7.81
BC: From 0 plf at -1.80 to 4 plf at 0.00
BC: From 2 plf at 0.00 to 2 plf at 7.81
TC: 16 lb Conc. Load at 1.27
TC: 24 lb Conc. Load at 3.07
TC: 114 lb Conc. Load at 4.87
TC: 74 lb Conc. Load at 5.47
BC: 20 lb Conc. Load at 1.27
BC: 27 lb Conc. Load at 3.07
BC: 80 lb Conc. Load at 4.87
BC: 54 lb Conc. Load at 5.47

Wind

Wind loads and reactions based on MWFRS.
Wind loading based on both gable and hip roof types.

Additional Notes

The overall height of this truss excluding overhang is 2-7-10.

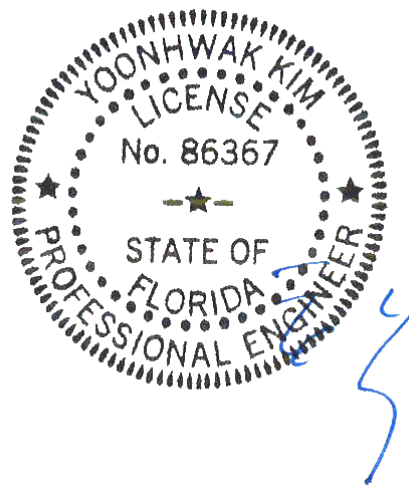

FL REG# 278, Yoonhwak Kim, FL PE #86367
02/03/2022

****WARNING** READ AND FOLLOW ALL NOTES ON THIS DRAWING!**
****IMPORTANT** FURNISH THIS DRAWING TO ALL CONTRACTORS INCLUDING THE INSTALLERS**
Trusses require extreme care in fabricating, handling, shipping, installing and bracing. Refer to and follow the latest edition of BCSI (Building Component Safety Information, by TPI and SBCA) for safety practices prior to performing these functions. Installers shall provide temporary bracing per BCSI. Unless noted otherwise, top chord shall have properly attached structural sheathing and bottom chord shall have a properly attached rigid ceiling. Locations shown for permanent lateral restraint of webs shall have bracing installed per BCSI sections B3, B7, or B10, as applicable. Apply plates to each face of truss and position as shown above and on the Joint Details, unless noted otherwise. Refer to drawings 160A-Z for standard plate positions. Refer to job's General Notes page for additional information.
Alpine, a division of ITW Building Components Group Inc. shall not be responsible for any deviation from this drawing, any failure to build the truss in conformance with ANSI/TPI 1, or for handling, shipping, installation and bracing of trusses. A seal on this drawing or cover page listing this drawing, indicates acceptance of professional engineering responsibility solely for the design shown. The suitability and use of this drawing for any structure is the responsibility of the Building Designer per ANSI/TPI 1 Sec.2.
For more information see these web sites: Alpine: alpineitw.com; TPI: tpinst.org; SBCA: sbcindustry.com; ICC: iccsafe.org; AWC: awc.org



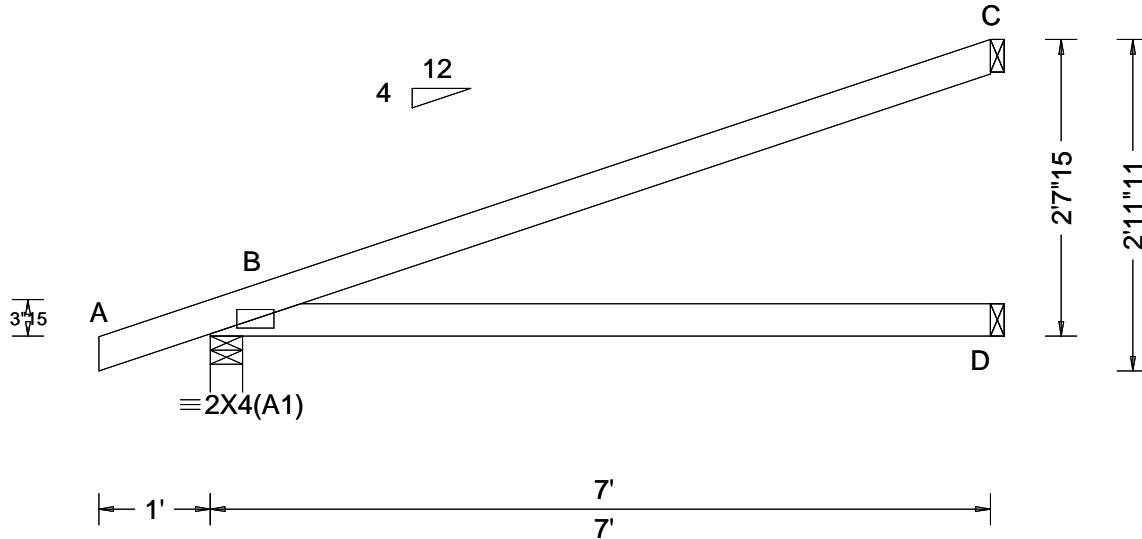

Loading Criteria (psf) TCCL: 20.00 TCCL: 10.00 BCLL: 0.00 BCDL: 10.00 Des Ld: 40.00 NCBCLL: 10.00 Soffit: 2.00 Load Duration: 1.25 Spacing: 24.0 "	Wind Criteria Wind Std: ASCE 7-16 Speed: 130 mph Enclosure: Closed Risk Category: II EXP: C Kzt: NA Mean Height: 15.00 ft TCCL: 5.0 psf BCDL: 5.0 psf MWFRS Parallel Dist: 0 to h/2 C&C Dist a: 3.00 ft Loc. from endwall: not in 4.50 ft GCcpi: 0.18 Wind Duration: 1.60	Snow Criteria (Pg,Pf in PSF) Pg: NA Ct: NA CAT: NA Pf: NA Ce: NA Lu: NA Cs: NA Snow Duration: NA Building Code: FBC 7th Ed. 2020 Res. TPI Std: 2014 Rep Fac: Yes FT/RT:20(0)/10(0) Plate Type(s): WAVE	Defl/CSI Criteria PP Deflection in loc L/defl L/# VERT(LL): NA VERT(CL): NA HORZ(LL): 0.016 D - - HORZ(TL): 0.032 D - - Creep Factor: 2.0 Max TC CSI: 0.703 Max BC CSI: 0.503 Max Web CSI: 0.000 VIEW Ver: 21.01.01A.0521.20	▲ Maximum Reactions (lbs)																																			
				<table border="1"> <thead> <tr> <th rowspan="2">Loc</th> <th colspan="3">Gravity</th> <th colspan="3">Non-Gravity</th> </tr> <tr> <th>R+</th> <th>/R-</th> <th>/Rh</th> <th>/Rw</th> <th>/U</th> <th>/RL</th> </tr> </thead> <tbody> <tr> <td>B</td> <td>361</td> <td>/-</td> <td>/-</td> <td>/235</td> <td>/57</td> <td>/92</td> </tr> <tr> <td>D</td> <td>128</td> <td>/-</td> <td>/-</td> <td>/73</td> <td>/-</td> <td>/-</td> </tr> <tr> <td>C</td> <td>186</td> <td>/-</td> <td>/-</td> <td>/104</td> <td>/79</td> <td>/-</td> </tr> </tbody> </table>		Loc	Gravity			Non-Gravity			R+	/R-	/Rh	/Rw	/U	/RL	B	361	/-	/-	/235	/57	/92	D	128	/-	/-	/73	/-	/-	C	186	/-	/-	/104	/79	/-
Loc	Gravity			Non-Gravity																																			
	R+	/R-	/Rh	/Rw	/U	/RL																																	
B	361	/-	/-	/235	/57	/92																																	
D	128	/-	/-	/73	/-	/-																																	
C	186	/-	/-	/104	/79	/-																																	

Lumber

Top chord: 2x4 SP #2;
 Bot chord: 2x4 SP #2;

Wind

Wind loads based on MWFRS with additional C&C member design.
 Wind loading based on both gable and hip roof types.

Additional Notes

The overall height of this truss excluding overhang is 2-7-15.

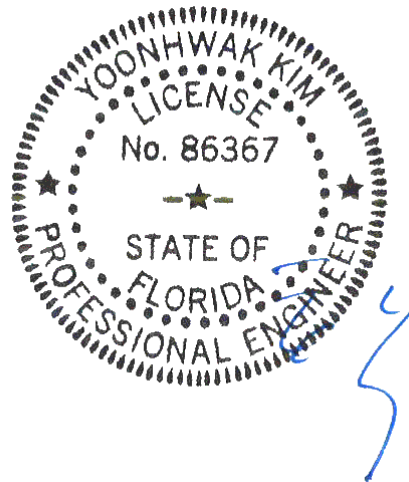

FL REG# 278, Yoonhwak Kim, FL PE #86367
 02/03/2022

****WARNING** READ AND FOLLOW ALL NOTES ON THIS DRAWING!**
****IMPORTANT** FURNISH THIS DRAWING TO ALL CONTRACTORS INCLUDING THE INSTALLERS**
 Trusses require extreme care in fabricating, handling, shipping, installing and bracing. Refer to and follow the latest edition of BCSI (Building Component Safety Information, by TPI and SBCA) for safety practices prior to performing these functions. Installers shall provide temporary bracing per BCSI. Unless noted otherwise, top chord shall have properly attached structural sheathing and bottom chord shall have a properly attached rigid ceiling. Locations shown for permanent lateral restraint of webs shall have bracing installed per BCSI sections B3, B7, or B10, as applicable. Apply plates to each face of truss and position as shown above and on the Joint Details, unless noted otherwise. Refer to drawings 160A-Z for standard plate positions. Refer to job's General Notes page for additional information.
 Alpine, a division of ITW Building Components Group Inc. shall not be responsible for any deviation from this drawing, any failure to build the truss in conformance with ANSI/TPI 1, or for handling, shipping, installation and bracing of trusses. A seal on this drawing or cover page listing this drawing, indicates acceptance of professional engineering responsibility solely for the design shown. The suitability and use of this drawing for any structure is the responsibility of the Building Designer per ANSI/TPI 1 Sec.2.
 For more information see these web sites: Alpine: alpineitw.com; TPI: tpinst.org; SBCA: sbcindustry.com; ICC: iccsafe.org; AWC: awc.org



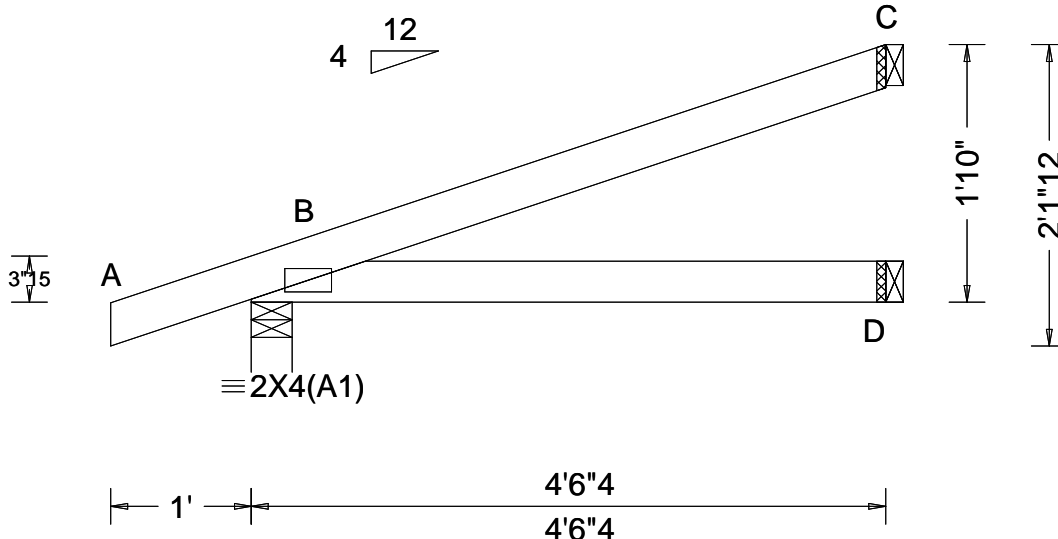

Loading Criteria (psf) TCCL: 20.00 TCCL: 10.00 BCLL: 0.00 BCDL: 10.00 Des Ld: 40.00 NCBCLL: 10.00 Soffit: 2.00 Load Duration: 1.25 Spacing: 24.0 "	Wind Criteria Wind Std: ASCE 7-16 Speed: 130 mph Enclosure: Closed Risk Category: II EXP: C Kzt: NA Mean Height: 15.00 ft TCCL: 5.0 psf BCDL: 5.0 psf MWFRS Parallel Dist: 0 to h/2 C&C Dist a: 3.00 ft Loc. from endwall: Any GCpi: 0.18 Wind Duration: 1.60	Snow Criteria (Pg,Pf in PSF) Pg: NA Ct: NA CAT: NA Pf: NA Ce: NA Lu: NA Cs: NA Snow Duration: NA Building Code: FBC 7th Ed. 2020 Res. TPI Std: 2014 Rep Fac: Yes FT/RT:20(0)/10(0) Plate Type(s): WAVE	Defl/CSI Criteria PP Deflection in loc L/def L/# VERT(LL): NA VERT(CL): NA HORZ(LL): 0.004 D - - HORZ(TL): 0.007 D - - Creep Factor: 2.0 Max TC CSI: 0.339 Max BC CSI: 0.189 Max Web CSI: 0.000 VIEW Ver: 21.01.01A.0521.20	▲ Maximum Reactions (lbs) <table border="1"> <thead> <tr> <th rowspan="2">Loc</th> <th colspan="3">Gravity</th> <th colspan="3">Non-Gravity</th> </tr> <tr> <th>R+</th> <th>/R-</th> <th>/Rh</th> <th>/Rw</th> <th>/U</th> <th>/RL</th> </tr> </thead> <tbody> <tr> <td>B</td> <td>264</td> <td>-</td> <td>-</td> <td>/176</td> <td>/44</td> <td>/62</td> </tr> <tr> <td>D</td> <td>80</td> <td>-</td> <td>-</td> <td>/45</td> <td>-</td> <td>-</td> </tr> <tr> <td>C</td> <td>114</td> <td>-</td> <td>-</td> <td>/64</td> <td>/49</td> <td>-</td> </tr> </tbody> </table>	Loc	Gravity			Non-Gravity			R+	/R-	/Rh	/Rw	/U	/RL	B	264	-	-	/176	/44	/62	D	80	-	-	/45	-	-	C	114	-	-	/64	/49	-
				Loc		Gravity			Non-Gravity																													
R+	/R-	/Rh	/Rw		/U	/RL																																
B	264	-	-	/176	/44	/62																																
D	80	-	-	/45	-	-																																
C	114	-	-	/64	/49	-																																
Wind reactions based on MWFRS B Brg Width = 3.5 Min Req = 1.5 D Brg Width = 1.5 Min Req = - C Brg Width = 1.5 Min Req = - Bearing B is a rigid surface. Members not listed have forces less than 375#																																						

Lumber

Top chord: 2x4 SP #2;
 Bot chord: 2x4 SP #2;

Wind

Wind loads based on MWFRS with additional C&C member design.
 Wind loading based on both gable and hip roof types.

Additional Notes

The overall height of this truss excluding overhang is 1-10-0.

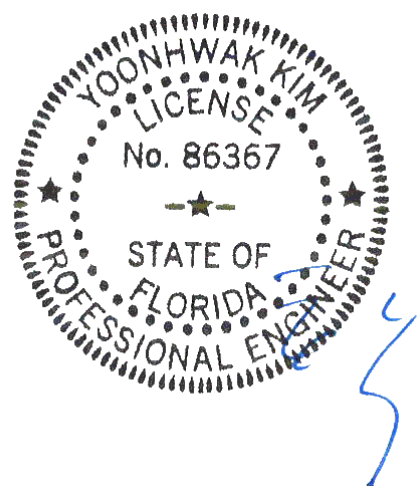

FL REG# 278, Yoonhwak Kim, FL PE #86367
 02/03/2022

****WARNING** READ AND FOLLOW ALL NOTES ON THIS DRAWING!**
****IMPORTANT** FURNISH THIS DRAWING TO ALL CONTRACTORS INCLUDING THE INSTALLERS**
 Trusses require extreme care in fabricating, handling, shipping, installing and bracing. Refer to and follow the latest edition of BCSI (Building Component Safety Information, by TPI and SBCA) for safety practices prior to performing these functions. Installers shall provide temporary bracing per BCSI. Unless noted otherwise, top chord shall have properly attached structural sheathing and bottom chord shall have a properly attached rigid ceiling. Locations shown for permanent lateral restraint of webs shall have bracing installed per BCSI sections B3, B7, or B10, as applicable. Apply plates to each face of truss and position as shown above and on the Joint Details, unless noted otherwise. Refer to drawings 160A-Z for standard plate positions. Refer to job's General Notes page for additional information.
 Alpine, a division of ITW Building Components Group Inc. shall not be responsible for any deviation from this drawing, any failure to build the truss in conformance with ANSI/TPI 1, or for handling, shipping, installation and bracing of trusses. A seal on this drawing or cover page listing this drawing, indicates acceptance of professional engineering responsibility solely for the design shown. The suitability and use of this drawing for any structure is the responsibility of the Building Designer per ANSI/TPI 1 Sec.2.
 For more information see these web sites: Alpine: alpineitw.com; TPI: tpinst.org; SBCA: sbcindustry.com; ICC: iccsafe.org; AWC: awc.org



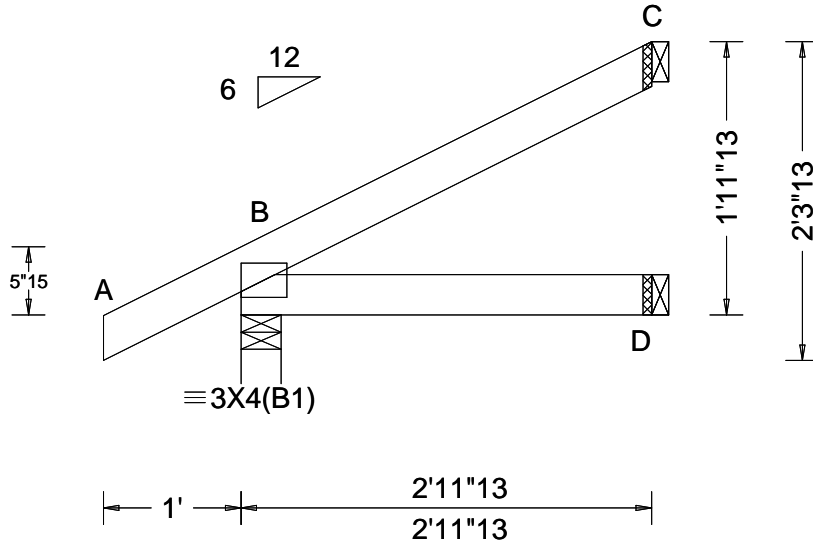

Loading Criteria (psf) TCCL: 20.00 TCCL: 10.00 BCLL: 0.00 BCDL: 10.00 Des Ld: 40.00 NCBCLL: 10.00 Soffit: 2.00 Load Duration: 1.25 Spacing: 24.0 "	Wind Criteria Wind Std: ASCE 7-16 Speed: 130 mph Enclosure: Closed Risk Category: II EXP: C Kzt: NA Mean Height: 15.00 ft TCCL: 5.0 psf BCDL: 5.0 psf MWFRS Parallel Dist: 0 to h/2 C&C Dist a: 3.00 ft Loc. from endwall: not in 4.50 ft GCp1: 0.18 Wind Duration: 1.60	Snow Criteria (Pg,Pf in PSF) Pg: NA Ct: NA CAT: NA Pf: NA Ce: NA Lu: NA Cs: NA Snow Duration: NA Building Code: FBC 7th Ed. 2020 Res. TPI Std: 2014 Rep Fac: Yes FT/RT:20(0)/10(0) Plate Type(s): WAVE	Defl/CSI Criteria PP Deflection in loc L/defl L/# VERT(LL): NA VERT(CL): NA HORZ(LL): -0.001 C - - HORZ(TL): 0.001 D - - Creep Factor: 2.0 Max TC CSI: 0.163 Max BC CSI: 0.078 Max Web CSI: 0.000 VIEW Ver: 21.01.01A.0521.20	▲ Maximum Reactions (lbs) <table border="1"> <thead> <tr> <th rowspan="2">Loc</th> <th colspan="3">Gravity</th> <th colspan="3">Non-Gravity</th> </tr> <tr> <th>R+</th> <th>/R-</th> <th>/Rh</th> <th>/Rw</th> <th>/U</th> <th>/RL</th> </tr> </thead> <tbody> <tr> <td>B</td> <td>210</td> <td>/-</td> <td>/-</td> <td>/146</td> <td>/26</td> <td>/66</td> </tr> <tr> <td>D</td> <td>54</td> <td>/-</td> <td>/-</td> <td>/28</td> <td>/-</td> <td>/-</td> </tr> <tr> <td>C</td> <td>74</td> <td>/-</td> <td>/-</td> <td>/45</td> <td>/42</td> <td>/-</td> </tr> </tbody> </table>	Loc	Gravity			Non-Gravity			R+	/R-	/Rh	/Rw	/U	/RL	B	210	/-	/-	/146	/26	/66	D	54	/-	/-	/28	/-	/-	C	74	/-	/-	/45	/42	/-
				Loc		Gravity			Non-Gravity																													
R+	/R-	/Rh	/Rw		/U	/RL																																
B	210	/-	/-	/146	/26	/66																																
D	54	/-	/-	/28	/-	/-																																
C	74	/-	/-	/45	/42	/-																																
Wind reactions based on MWFRS B Brg Width = 3.5 Min Req = 1.5 D Brg Width = 1.5 Min Req = - C Brg Width = 1.5 Min Req = - Bearing B is a rigid surface. Members not listed have forces less than 375#																																						

Lumber

Top chord: 2x4 SP #2;
 Bot chord: 2x4 SP #2;

Wind

Wind loads based on MWFRS with additional C&C member design.
 Wind loading based on both gable and hip roof types.

Additional Notes

The overall height of this truss excluding overhang is 1-11-13.

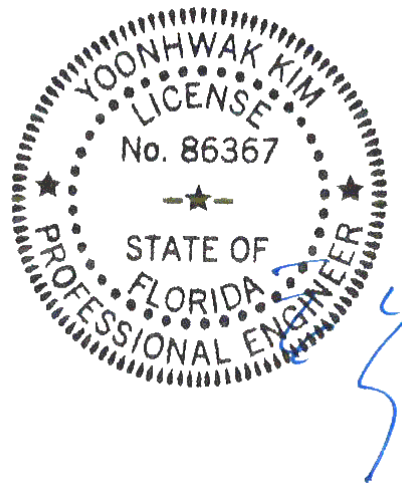

FL REG# 278, Yoonhwak Kim, FL PE #86367
 02/03/2022

****WARNING** READ AND FOLLOW ALL NOTES ON THIS DRAWING!**
****IMPORTANT** FURNISH THIS DRAWING TO ALL CONTRACTORS INCLUDING THE INSTALLERS**
 Trusses require extreme care in fabricating, handling, shipping, installing and bracing. Refer to and follow the latest edition of BCSI (Building Component Safety Information, by TPI and SBCA) for safety practices prior to performing these functions. Installers shall provide temporary bracing per BCSI. Unless noted otherwise, top chord shall have properly attached structural sheathing and bottom chord shall have a properly attached rigid ceiling. Locations shown for permanent lateral restraint of webs shall have bracing installed per BCSI sections B3, B7, or B10, as applicable. Apply plates to each face of truss and position as shown above and on the Joint Details, unless noted otherwise. Refer to drawings 160A-Z for standard plate positions. Refer to job's General Notes page for additional information.
 Alpine, a division of ITW Building Components Group Inc. shall not be responsible for any deviation from this drawing, any failure to build the truss in conformance with ANSI/TPI 1, or for handling, shipping, installation and bracing of trusses. A seal on this drawing or cover page listing this drawing, indicates acceptance of professional engineering responsibility solely for the design shown. The suitability and use of this drawing for any structure is the responsibility of the Building Designer per ANSI/TPI 1 Sec.2.
 For more information see these web sites: Alpine: alpineitw.com; TPI: tpinst.org; SBCA: sbcindustry.com; ICC: iccsafe.org; AWC: awc.org



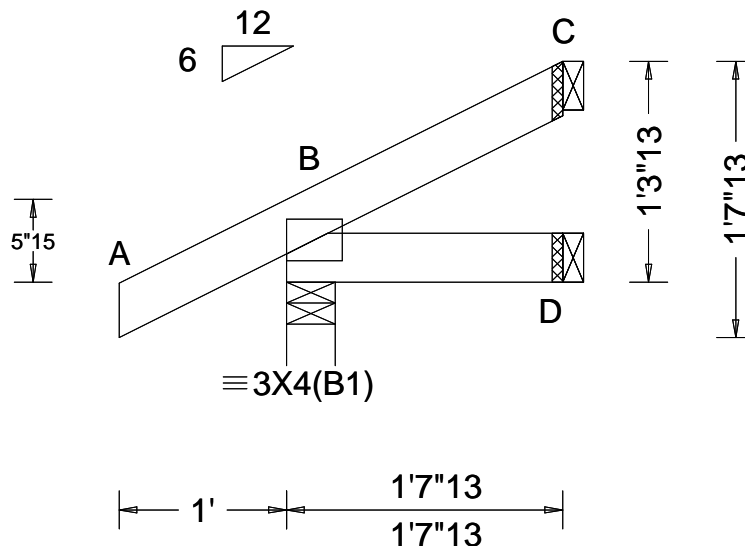

Loading Criteria (psf) TCCL: 20.00 TCCL: 10.00 BCLL: 0.00 BCDL: 10.00 Des Ld: 40.00 NCBCLL: 10.00 Soffit: 2.00 Load Duration: 1.25 Spacing: 24.0 "	Wind Criteria Wind Std: ASCE 7-16 Speed: 130 mph Enclosure: Closed Risk Category: II EXP: C Kzt: NA Mean Height: 15.00 ft TCCL: 5.0 psf BCDL: 5.0 psf MWFRS Parallel Dist: 0 to h/2 C&C Dist a: 3.00 ft Loc. from endwall: Any GCp: 0.18 Wind Duration: 1.60	Snow Criteria (Pg,Pf in PSF) Pg: NA Ct: NA CAT: NA Pf: NA Ce: NA Lu: NA Cs: NA Snow Duration: NA Building Code: FBC 7th Ed. 2020 Res. TPI Std: 2014 Rep Fac: Yes FT/RT:20(0)/10(0) Plate Type(s): WAVE	Defl/CSI Criteria PP Deflection in loc L/def L/# VERT(LL): NA VERT(CL): NA HORZ(LL): -0.000 C - - HORZ(TL): 0.000 C - - Creep Factor: 2.0 Max TC CSI: 0.102 Max BC CSI: 0.018 Max Web CSI: 0.000 VIEW Ver: 21.01.01A.0521.20	▲ Maximum Reactions (lbs) <table border="1"> <thead> <tr> <th rowspan="2">Loc</th> <th colspan="3">Gravity</th> <th colspan="3">Non-Gravity</th> </tr> <tr> <th>R+</th> <th>/R-</th> <th>/Rh</th> <th>/Rw</th> <th>/U</th> <th>/RL</th> </tr> </thead> <tbody> <tr> <td>B</td> <td>168</td> <td>-</td> <td>-</td> <td>/121</td> <td>/25</td> <td>/42</td> </tr> <tr> <td>D</td> <td>27</td> <td>-</td> <td>-</td> <td>/14</td> <td>-</td> <td>-</td> </tr> <tr> <td>C</td> <td>24</td> <td>-</td> <td>-</td> <td>/14</td> <td>/20</td> <td>-</td> </tr> </tbody> </table>	Loc	Gravity			Non-Gravity			R+	/R-	/Rh	/Rw	/U	/RL	B	168	-	-	/121	/25	/42	D	27	-	-	/14	-	-	C	24	-	-	/14	/20	-
				Loc		Gravity			Non-Gravity																													
R+	/R-	/Rh	/Rw		/U	/RL																																
B	168	-	-	/121	/25	/42																																
D	27	-	-	/14	-	-																																
C	24	-	-	/14	/20	-																																
Wind reactions based on MWFRS B Brg Width = 3.5 Min Req = 1.5 D Brg Width = 1.5 Min Req = - C Brg Width = 1.5 Min Req = - Bearing B is a rigid surface. Members not listed have forces less than 375#																																						

Lumber

Top chord: 2x4 SP #2;
 Bot chord: 2x4 SP #2;

Wind

Wind loads based on MWFRS with additional C&C member design.
 Wind loading based on both gable and hip roof types.

Additional Notes

The overall height of this truss excluding overhang is 1-3-13.

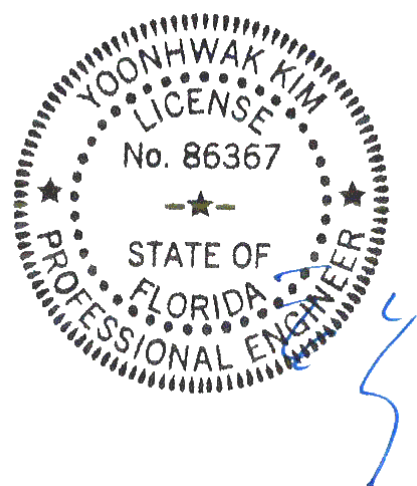

FL REG# 278, Yoonhwak Kim, FL PE #86367
 02/03/2022

****WARNING** READ AND FOLLOW ALL NOTES ON THIS DRAWING!**
****IMPORTANT** FURNISH THIS DRAWING TO ALL CONTRACTORS INCLUDING THE INSTALLERS**
 Trusses require extreme care in fabricating, handling, shipping, installing and bracing. Refer to and follow the latest edition of BCSI (Building Component Safety Information, by TPI and SBCA) for safety practices prior to performing these functions. Installers shall provide temporary bracing per BCSI. Unless noted otherwise, top chord shall have properly attached structural sheathing and bottom chord shall have a properly attached rigid ceiling. Locations shown for permanent lateral restraint of webs shall have bracing installed per BCSI sections B3, B7, or B10, as applicable. Apply plates to each face of truss and position as shown above and on the Joint Details, unless noted otherwise. Refer to drawings 160A-Z for standard plate positions. Refer to job's General Notes page for additional information.
 Alpine, a division of ITW Building Components Group Inc. shall not be responsible for any deviation from this drawing, any failure to build the truss in conformance with ANSI/TPI 1, or for handling, shipping, installation and bracing of trusses. A seal on this drawing or cover page listing this drawing, indicates acceptance of professional engineering responsibility solely for the design shown. The suitability and use of this drawing for any structure is the responsibility of the Building Designer per ANSI/TPI 1 Sec.2.
 For more information see these web sites: Alpine: alpineitw.com; TPI: tpinst.org; SBCA: sbcindustry.com; ICC: iccsafe.org; AWC: awc.org



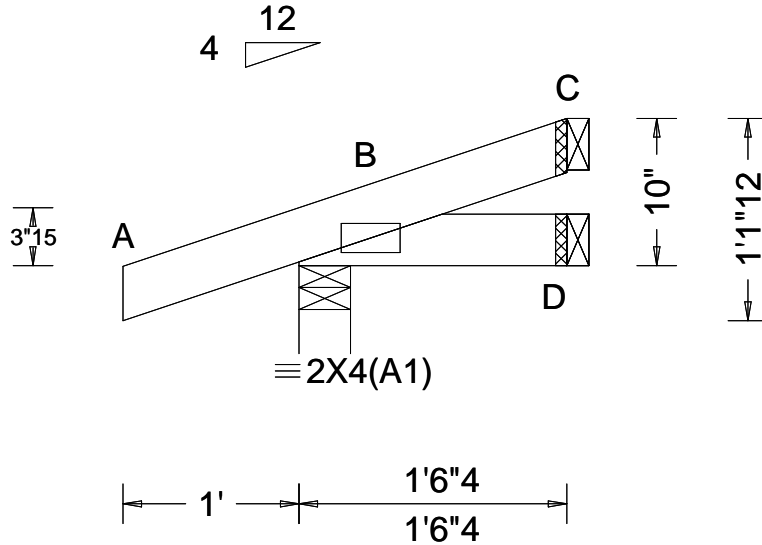

Loading Criteria (psf)	Wind Criteria	Snow Criteria (Pg,Pf in PSF)	Defl/CSI Criteria	▲ Maximum Reactions (lbs)						
				Gravity			Non-Gravity			
TCLL: 20.00	Wind Std: ASCE 7-16	Pg: NA Ct: NA CAT: NA	PP Deflection in loc L/def L/#	Loc	R+	/R-	/Rh	/Rw	/U	/RL
TCDL: 10.00	Speed: 130 mph	Pf: NA Ce: NA	VERT(LL): NA	B	164	/-	/-	/116	/43	/27
BCLL: 0.00	Enclosure: Closed	Lu: NA Cs: NA	VERT(CL): NA	D	20	/-	/-	/11	/1	/-
BCDL: 10.00	Risk Category: II	Snow Duration: NA	HORZ(LL): 0.000 D - -	C	16	/-	/-	/10	/9	/-
Des Ld: 40.00	EXP: C Kzt: NA	Building Code:	HORZ(TL): 0.000 D - -	Wind reactions based on MWFRS						
NCBCLL: 10.00	Mean Height: 15.00 ft	FBC 7th Ed. 2020 Res.	Creep Factor: 2.0	B Brg Width = 3.5 Min Req = 1.5						
Soffit: 2.00	TCDL: 5.0 psf	TPI Std: 2014	Max TC CSI: 0.122	D Brg Width = 1.5 Min Req = -						
Load Duration: 1.25	BCDL: 5.0 psf	Rep Fac: Yes	Max BC CSI: 0.014	C Brg Width = 1.5 Min Req = -						
Spacing: 24.0 "	MWFRS Parallel Dist: 0 to h/2	FT/RT:20(0)/10(0)	Max Web CSI: 0.000	Bearing B is a rigid surface.						
	C&C Dist a: 3.00 ft	Plate Type(s):	VIEW Ver: 21.01.01A.0521.20	Members not listed have forces less than 375#						
	Loc. from endwall: Any	WAVE								
	GCp1: 0.18									
	Wind Duration: 1.60									

Lumber

Top chord: 2x4 SP #2;
Bot chord: 2x4 SP #2;

Wind

Wind loads based on MWFRS with additional C&C member design.
Wind loading based on both gable and hip roof types.

Additional Notes

The overall height of this truss excluding overhang is 0-10-0.

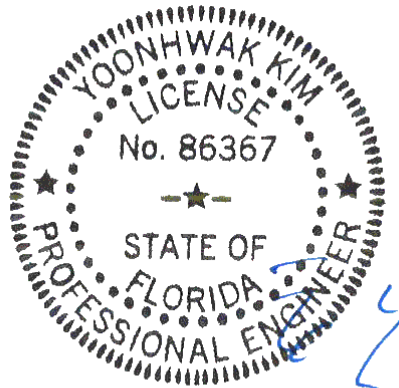

FL REG# 278, Yoonhwak Kim, FL PE #86367
02/03/2022

****WARNING** READ AND FOLLOW ALL NOTES ON THIS DRAWING!**
****IMPORTANT** FURNISH THIS DRAWING TO ALL CONTRACTORS INCLUDING THE INSTALLERS**
Trusses require extreme care in fabricating, handling, shipping, installing and bracing. Refer to and follow the latest edition of BCSI (Building Component Safety Information, by TPI and SBCA) for safety practices prior to performing these functions. Installers shall provide temporary bracing per BCSI. Unless noted otherwise, top chord shall have properly attached structural sheathing and bottom chord shall have a properly attached rigid ceiling. Locations shown for permanent lateral restraint of webs shall have bracing installed per BCSI sections B3, B7, or B10, as applicable. Apply plates to each face of truss and position as shown above and on the Joint Details, unless noted otherwise. Refer to drawings 160A-Z for standard plate positions. Refer to job's General Notes page for additional information.
Alpine, a division of ITW Building Components Group Inc. shall not be responsible for any deviation from this drawing, any failure to build the truss in conformance with ANSI/TPI 1, or for handling, shipping, installation and bracing of trusses. A seal on this drawing or cover page listing this drawing, indicates acceptance of professional engineering responsibility solely for the design shown. The suitability and use of this drawing for any structure is the responsibility of the Building Designer per ANSI/TPI 1 Sec.2.
For more information see these web sites: Alpine: alpineitw.com; TPI: tpinst.org; SBCA: sbcindustry.com; ICC: iccsafe.org; AWC: awc.org

Gable Stud Reinforcement Detail

ASCE 7-16: 140 mph Wind Speed, 15' Mean Height, Enclosed, Exposure C, Kzt = 1.00

- Or: 120 mph Wind Speed, 15' Mean Height, Partially Enclosed, Exposure C, Kzt = 1.00
- Or: 120 mph Wind Speed, 15' Mean Height, Enclosed, Exposure D, Kzt = 1.00
- Or: 100 mph Wind Speed, 15' Mean Height, Partially Enclosed, Exposure D, Kzt = 1.00

Max Gable Vertical Length	2x4 Gable Vertical		Brace Grade	No Braces	(1) 1x4 'L' Brace *		(1) 2x4 'L' Brace *		(2) 2x4 'L' Brace **		(1) 2x6 'L' Brace *		(2) 2x6 'L' Brace **	
	Spacing	Species			Group A	Group B	Group A	Group B	Group A	Group B	Group A	Group B	Group A	Group B
	24" o.c.	SPF	#1 / #2	#1 / #2	4' 3"	7' 3"	7' 7"	8' 7"	8' 11"	10' 3"	10' 8"	13' 6"	14' 0"	14' 0"
#3				4' 1"	6' 7"	7' 1"	8' 6"	8' 10"	10' 1"	10' 6"	13' 4"	13' 10"	14' 0"	14' 0"
Stud				4' 1"	6' 7"	7' 0"	8' 6"	8' 10"	10' 1"	10' 6"	13' 4"	13' 10"	14' 0"	14' 0"
HF			#1	4' 6"	7' 4"	7' 8"	8' 8"	9' 0"	10' 4"	10' 9"	11' 8"	14' 0"	14' 0"	14' 0"
			#2	4' 3"	7' 3"	7' 7"	8' 7"	8' 11"	10' 3"	10' 8"	13' 6"	14' 0"	14' 0"	14' 0"
			Standard	4' 1"	5' 8"	6' 0"	7' 7"	8' 1"	10' 1"	10' 6"	11' 10"	12' 8"	14' 0"	14' 0"
SP		DFL	#1	4' 6"	7' 4"	7' 8"	8' 8"	9' 0"	10' 4"	10' 9"	11' 8"	14' 0"	14' 0"	14' 0"
			#2	4' 3"	7' 3"	7' 7"	8' 7"	8' 11"	10' 3"	10' 8"	13' 6"	14' 0"	14' 0"	14' 0"
			Standard	4' 0"	5' 3"	5' 7"	7' 0"	7' 6"	9' 6"	10' 2"	11' 0"	11' 10"	14' 0"	14' 0"
		SPF	#1 / #2	4' 11"	8' 4"	8' 8"	9' 10"	10' 3"	11' 8"	12' 2"	14' 0"	14' 0"	14' 0"	14' 0"
			#3	4' 8"	8' 1"	8' 8"	9' 8"	10' 1"	11' 7"	12' 1"	14' 0"	14' 0"	14' 0"	14' 0"
			Stud	4' 8"	8' 1"	8' 6"	9' 8"	10' 1"	11' 7"	12' 1"	14' 0"	14' 0"	14' 0"	14' 0"
SP	DFL	#1	5' 1"	8' 5"	8' 9"	9' 11"	10' 4"	11' 10"	12' 4"	14' 0"	14' 0"	14' 0"	14' 0"	
		#2	4' 11"	8' 4"	8' 8"	9' 10"	10' 3"	11' 8"	12' 2"	14' 0"	14' 0"	14' 0"	14' 0"	
		Standard	4' 9"	7' 4"	7' 9"	9' 9"	10' 2"	11' 8"	12' 1"	14' 0"	14' 0"	14' 0"	14' 0"	
	SPF	#1 / #2	5' 1"	9' 0"	9' 4"	10' 8"	11' 1"	12' 9"	13' 3"	14' 0"	14' 0"	14' 0"	14' 0"	
		#3	5' 1"	9' 0"	9' 4"	10' 8"	11' 1"	12' 9"	13' 3"	14' 0"	14' 0"	14' 0"	14' 0"	
		Stud	5' 1"	9' 0"	9' 4"	10' 8"	11' 1"	12' 9"	13' 3"	14' 0"	14' 0"	14' 0"	14' 0"	
SP	DFL	#1	5' 8"	9' 3"	9' 8"	10' 11"	11' 4"	13' 0"	13' 6"	14' 0"	14' 0"	14' 0"	14' 0"	
		#2	5' 5"	9' 2"	9' 6"	10' 10"	11' 3"	12' 11"	13' 5"	14' 0"	14' 0"	14' 0"	14' 0"	
		Standard	5' 3"	8' 5"	9' 0"	10' 9"	11' 2"	12' 10"	13' 4"	14' 0"	14' 0"	14' 0"	14' 0"	
	SPF	#1 / #2	5' 3"	8' 5"	9' 0"	10' 9"	11' 2"	12' 10"	13' 4"	14' 0"	14' 0"	14' 0"	14' 0"	
		#3	5' 3"	8' 5"	9' 0"	10' 9"	11' 2"	12' 10"	13' 4"	14' 0"	14' 0"	14' 0"	14' 0"	
		Stud	5' 3"	8' 5"	9' 0"	10' 9"	11' 2"	12' 10"	13' 4"	14' 0"	14' 0"	14' 0"	14' 0"	
12" o.c.	SPF	DFL	#1 / #2	5' 1"	7' 5"	7' 11"	9' 11"	10' 7"	12' 9"	13' 3"	14' 0"	14' 0"	14' 0"	
			#3	5' 1"	7' 5"	7' 11"	9' 11"	10' 7"	12' 9"	13' 3"	14' 0"	14' 0"	14' 0"	
			Standard	5' 1"	7' 5"	7' 11"	9' 11"	10' 7"	12' 9"	13' 3"	14' 0"	14' 0"	14' 0"	

Bracing Group Species and Grades:

Group A:			
Spruce-Pine-Fir		Hem-Fir	
#1 / #2	Standard	#2	Stud
#3	Stud	#3	Standard
Douglas Fir-Larch		Southern Pine***	
#3		#3	
Stud		Stud	
Standard		Standard	
Group B:			
Hem-Fir			
#1 & Btr			
#1			
Douglas Fir-Larch		Southern Pine***	
#1		#1	
#2		#2	

1x4 Braces shall be SRB (Stress-Rated Board).
 ***For 1x4 So. Pine use only Industrial 55 or Industrial 45 Stress-Rated Boards. Group B values may be used with these grades.

Gable Truss Detail Notes:
 Wind Load deflection criterion is L/240.
 Provide uplift connections for 55 plf over continuous bearing (5 psf TC Dead Load).
 Gable end supports load from 4' 0" outlookers with 2' 0" overhang, or 12' plywood overhang.

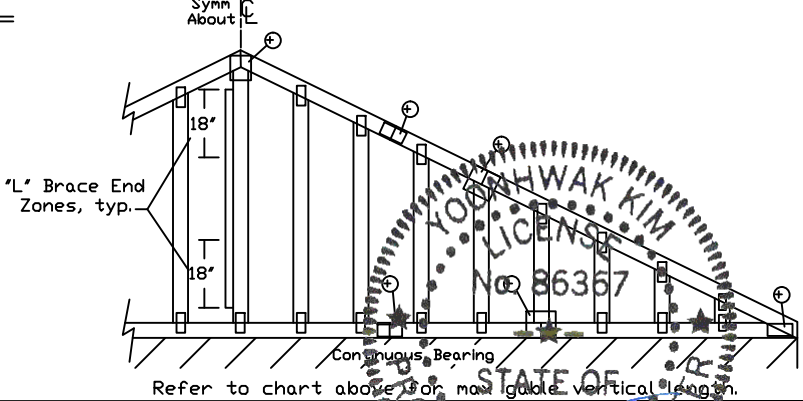
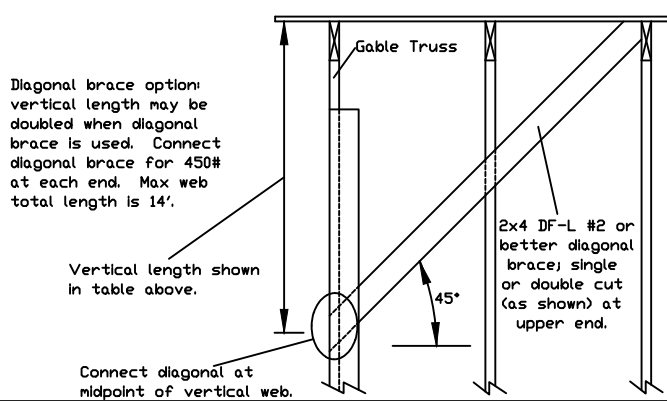

Attach 'L' braces with 10d (0.128"x3.0" min) nails.
 * For (1) 'L' brace: space nails at 2' o.c. in 18' end zones and 4' o.c. between zones.
 ** For (2) 'L' braces: space nails at 3' o.c. in 18' end zones and 6' o.c. between zones.
 'L' bracing must be a minimum of 80% of web member length.

Gable Vertical Plate Sizes	
Vertical Length	No Splice
Less than 4' 0"	1X4 or 2X3
Greater than 4' 0"	3X4

+ Refer to common truss design for peak, splice, and heel plates.
 Refer to the Building Designer for conditions not addressed by this detail.



WARNING: READ AND FOLLOW ALL NOTES ON THIS DRAWING. FURNISH THIS DRAWING TO ALL CONTRACTORS INCLUDING THE INSTALLERS.
 Trusses require extreme care in fabricating, handling, shipping, installing and bracing. Refer to and follow the latest edition of BCSI (Building Component Safety Information, by TPI and SBCA) for safety practices prior to performing these functions. Installers shall provide temporary bracing per BCSI. Unless noted otherwise, top chord shall have properly attached structural sheathing and bottom chord shall have a properly attached rigid ceiling. Locations shown for permanent lateral restraint of webs shall have bracing installed per BCSI sections B3, B7 or B10, as applicable. Apply plates to each face of truss and position as shown above and on the Joint Details, unless noted otherwise. Refer to drawings 150A-Z for standard plate positions.
 Alpine, a division of ITW Building Components Group Inc. shall not be responsible for any deviation from this drawing, any failure to build the truss in conformance with ANSI/TPI 1, or for handling, shipping, installation & bracing of trusses.
 A seal on this drawing or cover page listing this drawing, indicates acceptance of professional engineering responsibility solely for the design shown. The suitability and use of this drawing for any structure is the responsibility of the Building Designer per ANSI/TPI 1 Sec.2.
 For more information see this Job's general notes page and these web sites:
 ALPINE: www.alpineitw.com; TPI: www.tpinstr.org; SBCA: www.sbcacomponents.com; ICC: www.iccsafe.org

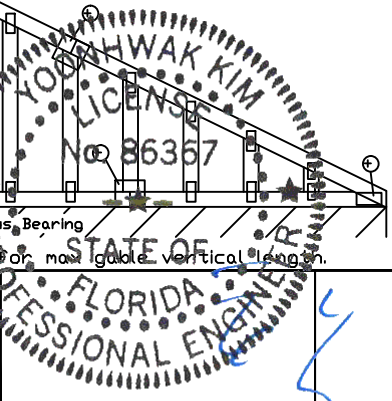

MAX. TOT. LD. 60 PSF
 MAX. SPACING 24.0"

REF ASCE7-16-GAB14015
 DATE 01/26/2018
 DRWG A14015ENC160118

CLR Reinforcing Member Substitution

This detail is to be used when a Continuous Lateral Restraint (CLR) is specified on a truss design but an alternative web reinforcement method is desired.

Notes:

This detail is only applicable for changing the specified CLR shown on single ply sealed designs to T-reinforcement or L-reinforcement or scab reinforcement.

Alternative reinforcement specified in chart below may be conservative. For minimum alternative reinforcement, re-run design with appropriate reinforcement type.

Use scabs instead of L- or T- reinforcement on webs with intersecting truss joints, such as K-web joints, that may interfere with proper application along the narrow face of the web.

Web Member Size	Specified CLR Restraint	Alternative Reinforcement T- or L- Reinf.	Scab Reinf.
2x3 or 2x4	1 row	2x4	1-2x4
2x3 or 2x4	2 rows	2x6	2-2x4
2x6	1 row	2x4	1-2x6
2x6	2 rows	2x6	2-2x4(*)
2x8	1 row	2x6	1-2x8
2x8	2 rows	2x6	2-2x6(*)

T-reinforcement, L-reinforcement, or scab reinforcement to be same species and grade or better than web member unless specified otherwise on Engineer's sealed design.

(*) Center scab on wide face of web. Apply (1) scab to each face of web.

T-Reinforcement or L-Reinforcement:

Apply to either side of web narrow face. Attach with 10d (0.128"x3.0",min) nails at 6" o.c. Reinforcing member is a minimum 80% of web member length.

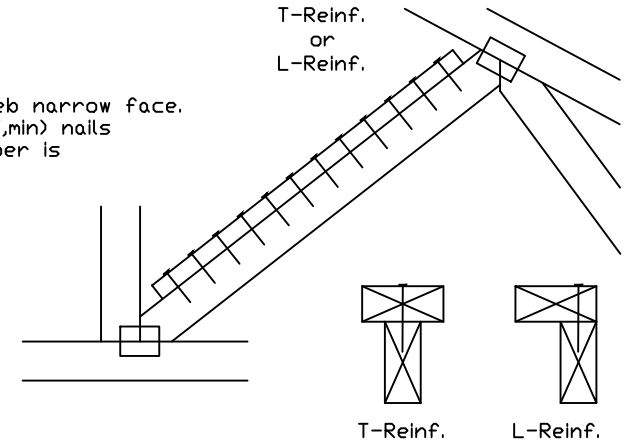

Scab Reinforcement:

Apply scab(s) to wide face of web. No more than (1) scab per face. Attach with 10d (0.128"x3.0",min) nails at 6" o.c. Reinforcing member is a minimum 80% of web member length.

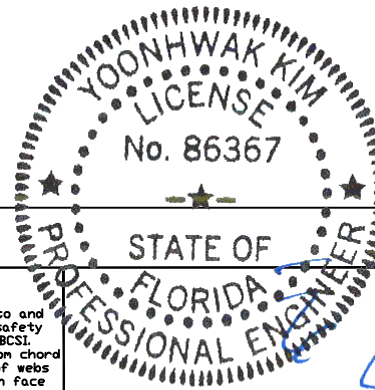
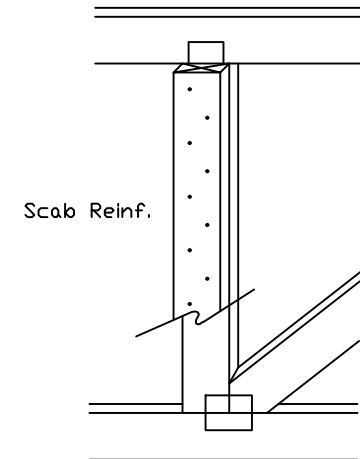

514 Earth City Expressway
Suite 242
Earth City, MO 63045

WARNING: READ AND FOLLOW ALL NOTES ON THIS DRAWING
IMPORTANT: FURNISH THIS DRAWING TO ALL CONTRACTORS INCLUDING THE INSTALLERS.

Trusses require extreme care in fabricating, handling, shipping, installing and bracing. Refer to and follow the latest edition of BCSI (Building Component Safety Information, by TPI and SBCA) for safety practices prior to performing these functions. Installers shall provide temporary bracing per BCSI. Unless noted otherwise, top chord shall have properly attached structural sheathing and bottom chord shall have a properly attached rigid ceiling. Locations shown for permanent lateral restraint of webs shall have bracing installed per BCSI sections B3, B7 or B10, as applicable. Apply plates to each face of truss and position as shown above and on the Joint Details, unless noted otherwise. Refer to drawings 150A-Z for standard plate positions.

Alpine, a division of ITW Building Components Group Inc. shall not be responsible for any deviation from this drawing, any failure to build the truss in conformance with ANSI/TPI 1, or for handling, shipping, installation & bracing of trusses.

A seal on this drawing or cover page listing this drawing, indicates acceptance of professional engineering responsibility solely for the design shown. The suitability and use of this drawing for any structure is the responsibility of the Building Designer per ANSI/TPI 1 Sec.2.

For more information see this job's general notes page and these web sites: www.alpineitw.com; www.tpinst.org; www.sbcacomponents.com; www.iccsafe.org.

TC LL	PSF	REF CLR Subst.
TC DL	PSF	DATE 01/02/19
BC DL	PSF	DRWG BRCLBSUB0119
BC LL	PSF	
TOT. LD.	PSF	
DUR. FAC.		
SPACING		

01/03/2023 Yoonhwak Kim, FL PE #86367

Gable Detail For Let-in Verticals

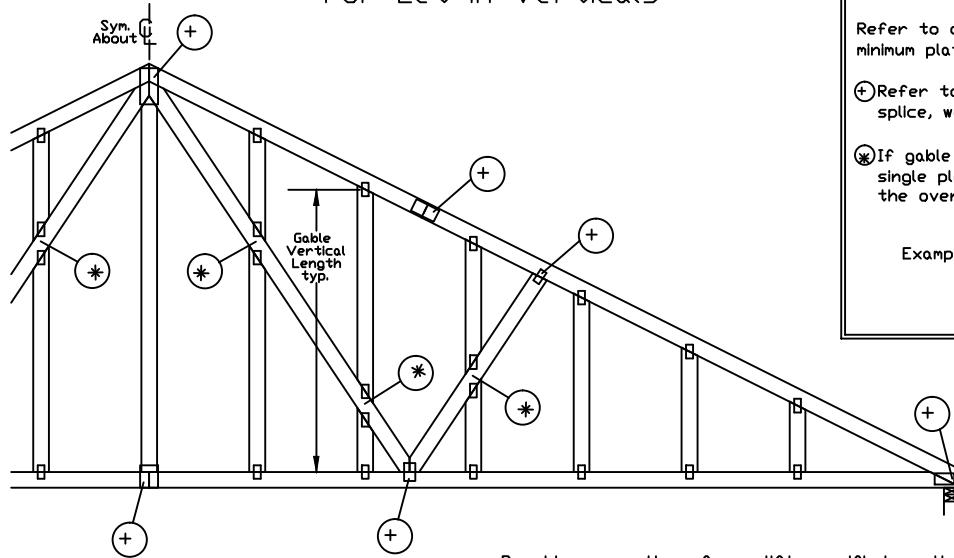

Gable Truss Plate Sizes

Refer to appropriate Alpine gable detail for minimum plate sizes for vertical studs.

⊕ Refer to Engineered truss design for peak, splice, web, and heel plates.

⊗ If gable vertical plates overlap, use a single plate that covers the total area of the overlapped plates to span the web.

Example:

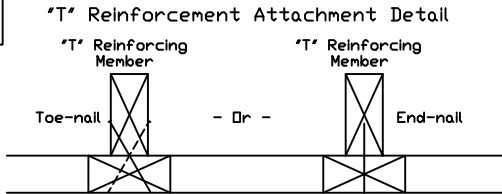

Provide connections for uplift specified on the engineered truss design.

Attach each 'T' reinforcing member with
End Driven Nails:
10d Common (0.148"x3",min) Nails at 4' o.c. plus
(4) nails in the top and bottom chords.

Toenailed Nails:
10d Common (0.148"x3",min) Toenails at 4' o.c. plus
(4) toenails in the top and bottom chords.

This detail to be used with the appropriate Alpine gable detail for ASCE wind load.

- ASCE 7-05 Gable Detail Drawings
A13015051014, A12015051014, A11015051014, A10015051014, A14015051014,
A13030051014, A12030051014, A11030051014, A10030051014, A14030051014
- ASCE 7-10 & ASCE 7-16 Gable Detail Drawings
A11515ENC100118, A12015ENC100118, A14015ENC100118, A16015ENC100118,
A18015ENC100118, A20015ENC100118, A20015END100118, A20015PE1D100118,
A11530ENC100118, A12030ENC100118, A14030ENC100118, A16030ENC100118,
A18030ENC100118, A20030ENC100118, A20030END100118, A20030PE1D100118,
S11515ENC100118, S12015ENC100118, S14015ENC100118, S16015ENC100118,
S18015ENC100118, S20015ENC100118, S20015END100118, S20015PE1D100118,
S11530ENC100118, S12030ENC100118, S14030ENC100118, S16030ENC100118,
S18030ENC100118, S20030ENC100118, S20030END100118, S20030PE1D100118

See appropriate Alpine gable detail for maximum unreinforced gable vertical length.

To convert from 'L' to 'T' reinforcing members, multiply 'T' increase by length (based on appropriate Alpine gable detail).

Maximum allowable 'T' reinforced gable vertical length is 14' from top to bottom chord.
'T' reinforcing member material must match size, specie, and grade of the 'L' reinforcing member.

Web Length Increase w/ 'T' Brace

'T' Reinf. Mbr. Size	'T' Increase
2x4	30 %
2x6	20 %

Example:
ASCE 7-10 Wind Speed = 120 mph
Mean Roof Height = 30 ft, Kzt = 1.00
Gable Vertical = 24' o.c. SP #3
'T' Reinforcing Member Size = 2x4
'T' Brace Increase (From Above) = 30% = 1.30
(1) 2x4 'L' Brace Length = 8' 7"
Maximum 'T' Reinforced Gable Vertical Length
1.30 x 8' 7" = 11' 2"

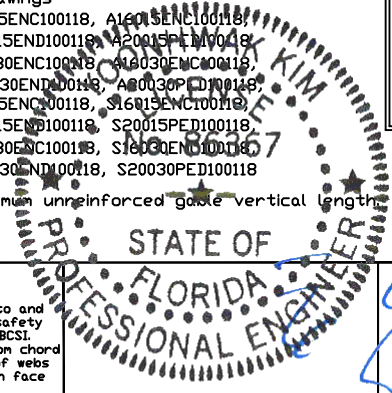
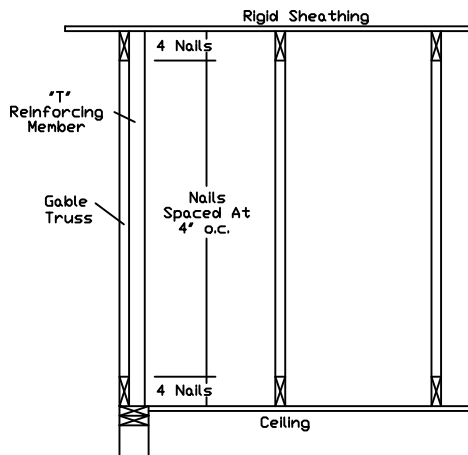

ALPINE
AN ITW COMPANY

514 Earth City Expressway
Suite 242
Earth City, MO 63045

WARNING: READ AND FOLLOW ALL NOTES ON THIS DRAWING
IMPORTANT: FURNISH THIS DRAWING TO ALL CONTRACTORS INCLUDING THE INSTALLERS.

Trusses require extreme care in fabricating, handling, shipping, installing and bracing. Refer to and follow the latest edition of BCSI (Building Component Safety Information, by TPI and SBCA) for safety practices prior to performing these functions. Installers shall provide temporary bracing per BCSI. Unless noted otherwise, top chord shall have properly attached structural sheathing and bottom chord shall have a properly attached rigid ceiling. Locations shown for permanent lateral restraint of webs of truss and position as shown above and on the Joint Details, unless noted otherwise. Refer to drawings 160A-Z for standard plate positions.

Alpine, a division of ITW Building Components Group Inc. shall not be responsible for any deviation from this drawing, any failure to build the truss in conformance with ANSI/TPI 1, or for handling, shipping, installation & bracing of trusses.

A seal on this drawing or cover page listing this drawing, indicates acceptance of professional engineering responsibility solely for the design shown. The suitability and use of this drawing for any structure is the responsibility of the Building Designer per ANSI/TPI 1 Sec.2.

For more information see this Job's general notes page and these web sites: www.alpineitw.com, www.tpinstr.org, www.sbcacomponents.com, www.iccsafe.org

REF	LET-IN VERT
DATE	01/02/2018
DRWG	GBLLETIN0118
MAX. TOT. LD.	60 PSF
DUR. FAC.	ANY
MAX. SPACING	24.0"