

FBC APPROVED PRODUCTS LIST					MAXIMUM ALLOWABLE WIND SPEED		
PRODUCT CATEGORY	SUB CATEGORY	MANUFACTURER	APPROVAL No. & DATE	QA EXPIRATION DATE	OPEN	ENCLOSED	PARTIALLY ENCLOSED
STRUCTURAL COMPONENTS	ROOF DECK	CAROLINA CARPORTS, INC. 26 Gauge AG Panel	FL6596.1-R7 12/12/23	04/05/27	180	180	180
STRUCTURAL COMPONENTS	STRUCTURAL WALL	CAROLINA CARPORTS, INC. 26 Gauge AG Panel	FL6702.1-R7 12/12/23	03/14/27	180	180	180
STRUCTURAL COMPONENTS	STRUCTURAL WALL	CAROLINA CARPORTS, INC. 26 Gauge Dutch Lap Wall Panel	FL6702.3-R7 12/12/23 **	03/14/27	N/A	164	143
EXTERIOR DOORS	SWINGING	ELIXIR DOOR AND METAL COMPANY Series 402-14	FL17996.3-R3 12/26/23	08/26/25	N/A	139	139
EXTERIOR DOORS	SWINGING	ELIXIR DOOR AND METAL COMPANY Series 407	FL17996.5-R3 12/26/23	08/19/25	N/A	174	155
EXTERIOR DOORS	ROLL-UP	ASTA INDUSTRIES INC. Model 203 (12' Max. Width)	FL8888.1-R7 11/06/23	12/31/24	N/A	180	174
EXTERIOR DOORS	ROLL-UP	CAROLINA CARPORTS, INC. Steel Roll Up Sheet Door (8' Max. Width)	FL16806.2-R6 12/13/23	04/05/27	N/A	180	180
EXTERIOR DOORS	ROLL-UP	CAROLINA CARPORTS, INC. Steel Roll-Up Sheet Door - (10' Max. Width)	FL16806.4-R6 12/13/23	04/05/27	N/A	180	172
EXTERIOR DOORS	ROLL-UP	CAROLINA CARPORTS, INC. Steel Roll-Up Sheet Door - (12' Max. Width)	FL16806.4-R6 12/13/23	04/05/27	N/A	179	154
EXTERIOR DOORS	ROLL-UP	CAROLINA CARPORTS, INC. Steel Roll-Up Sheet Door - (16' Max. Width)	FL4133.5-R1 12/13/23	04/05/27	N/A	163	142
WINDOWS	SINGLE HUNG	CGI WINDOWS AND DOORS Model SH 4000A	FL23358.2-R7 12/19/23	02/28/32	N/A	174	156

TABLE 1
RAFTER FRAME, END POST, GROUND ANCHOR AND PANEL FASTENER SPACING SPECIFICATIONS

RISK CATEGORY	WIND EXPOSURE CATEGORY	ULTIMATE WIND SPEED (MPH)	NOMINAL WIND SPEED (MPH)	MAXIMUM POST / RAFTER SPACING (FEET)	AVERAGE FASTENER SPACING ON-CENTERS ALONG RAFTERS OR PURLINS, AND POSTS OR GIRTS (INCHES)	
					INTERIOR POSTS/RAFTERS	END POSTS/RAFTERS
I	C	110 TO 150	89 TO 116	5.0	6	6
		151 TO 180	117 TO 139	4.0	6	6

NOTES: 1. Specifications applicable to 26 gauge metal roof and wall panels fastened directly to 12 or 14 gauge steel tube framing, or 18 gauge hat channel roof purlins.
2. Specifications applicable only for mean roof height of 20 feet or less, and roof slopes of 7° to 27° (1.5:12 to 6:12 pitch). Spacing requirements for other roof heights and/or slopes may vary.

GROUND ANCHOR SCHEDULE

		ULTIMATE WIND SPEED (mph)							
		110	120	130	140	150	160	170	180
BUILDING WIDTH (feet)	12								
	14								
	16								
	18								
	20								
	22								
	24								
	26								
	28								
	30								

DETAILS 1C AND 1D SHOWN ON SHEET 4 OF 6

METAL CARPORT INSTALLATION PLANS AND DETAILS AND FRAMING AND FASTENER SPECIFICATIONS

FOR CONSTRUCTION IN THE STATE OF FLORIDA

PREPARED FOR:
CAROLINA CARPORTS, INC.
P.O. BOX 1263
DOBSON, NORTH CAROLINA 27017

PREPARED BY:
BECHTOL ENGINEERING AND TESTING, INC.
605 WEST NEW YORK AVENUE
DELAND, FLORIDA 32720
Certificate of Authorization No. 00005492

NOTES:
1. DOORS AND WINDOWS SHOWN MAY BE SUBSTITUTED FOR DIFFERENT PRODUCT LINES AND/OR MODELS, PROVIDED THE FOLLOWING CONDITIONS ARE MET:
A. PRODUCT SHALL HAVE A VALID FBC PRODUCT APPROVAL.
B. COMPONENTS ARE INSTALLED ACCORDING TO MANUFACTURER'S INSTALLATION REQUIREMENTS.
2. FRAMING CONNECTIONS FOR DOOR AND WINDOW FRAMES REMAIN THE SAME FOR SUBSTITUTED PRODUCTS. HEADERS AND WINDOW RAILS MAY BE RAISED OR LOWERED AS NECESSARY TO ACCOMMODATE SUBSTITUTED PRODUCT.
** MAXIMUM POST SPACING FOR DUTCH LAP IS 4.0'

- GENERAL NOTES:**
- THESE PLANS PERTAIN ONLY TO THE STRUCTURE, INCLUDING MAIN WIND FORCE RESISTING SYSTEM, COMPONENTS AND CLADDING, AND BASE RAIL ANCHORAGE. OTHER DESIGN ISSUES, INCLUDING BUT NOT LIMITED TO PLUMBING, ELECTRICAL, INGRESS/EGRESS, PROPERTY SET-BACKS, FINISH FLOOR ELEVATION AND SLOPE, OR OTHER LOCAL ZONING REQUIREMENTS ARE THE RESPONSIBILITY OF OTHERS.
 - THESE STRUCTURES ARE DESIGNED AS NON-HABITABLE UTILITY/STORAGE BUILDINGS (RISK CATEGORY I) CAPABLE OF SUPPORTING DEAD LOAD OF THE STRUCTURE AND APPLICABLE LIVE AND WIND LOADS. IMPROVEMENTS NOT SPECIFICALLY ADDRESSED HEREIN, INCLUDING DOORS, WINDOWS, OR OTHER COMPONENTS NOT LISTED IN THE FBC APPROVED PRODUCTS LIST (THIS SHEET), AND NOT PROVIDED AND INSTALLED BY CAROLINA CARPORTS, INC., WHICH EXERT ADDITIONAL LOADS ON THE STRUCTURE, SHALL BE AT THE OWNER'S RISK. BECHTOL ENGINEERING AND TESTING, INC., SHALL NOT BE RESPONSIBLE FOR STRUCTURAL DAMAGE OR FAILURE DUE TO THE APPLICATION OF ADDITIONAL LOADS.
 - ALL STEEL TUBING SHALL BE 50 KSI GALVANIZED STEEL. ALL FASTENERS SHALL BE GALVANIZED OR STAINLESS STEEL OR ZINC PLATED.
 - ALL COMPONENTS AND CLADDING SHALL BE INSTALLED ACCORDING TO MANUFACTURER'S INSTALLATION INSTRUCTIONS, AND SHALL MEET THE DESIGN PRESSURES REQUIRED BY THE FLORIDA BUILDING CODE (FBC) AT THE LOCATION OF THE BUILDING WITHIN THE STATE OF FLORIDA.
 - ALL FIELD FRAMING CONNECTIONS SHALL BE #12-14 x 3/4" SELF DRILLING SCREWS WITHOUT CONTROL SEAL WASHER. ALL SHOP FRAMING CONNECTIONS SHALL BE WELDED.
 - CONCRETE SHALL HAVE A MINIMUM COMPRESSIVE STRENGTH OF 2500 PSI AT 28 DAYS. THE REINFORCING STEEL SHALL BE MINIMUM GRADE 40. CONCRETE SLAB FOUNDATIONS SHALL BE REINFORCED WITH 6X6-W1.4XW1.4 WELDED WIRE FABRIC COMPLYING WITH ASTM A 185, OR WITH SYNTHETIC FIBER REINFORCEMENT COMPLYING WITH ASTM C1116.
 - BASE RAIL GROUND ANCHOR REQUIREMENTS: ONE WITHIN 6" OF EVERY POST LOCATION, AND BOTH SIDES OF OPENINGS WHERE BASE RAIL IS ABSENT. GROUND ANCHORS ARE NOT REQUIRED FOR CONCRETE FOOTING AND/OR CONCRETE SLAB CONSTRUCTION. SEE GROUND ANCHOR SCHEDULE (THIS SHEET) FOR SPECIFIC GROUND ANCHOR SIZE REQUIREMENTS.
 - CONCRETE ANCHORS SHALL BE TAPCON REDHEAD LDT 1/2" x 5" OR EQUIVALENT OR WEJ-IT ANKR-TITE MODEL AT1252, OR SLEEVE ANCHOR MODEL HSA 1260, OR EQUIVALENT.
 - POST/RAFTER BRACING: BRACE ON EVERY POST/RAFTER CONNECTION, EXCEPT FOR END WALLS.
 - SLAB FOUNDATION SUBGRADE SOILS SHALL BE TERMITE TREATED AND COVERED WITH 6 MIL VAPOR RETARDER PER SECTION R318.1 OF THE FBC EIGHTH EDITION (2023) - RESIDENTIAL, AND SECTION 1816.1 OF THE FBC EIGHTH EDITION (2023) - BUILDING. MINIMUM ALLOWABLE FOUNDATION SOIL CONTACT BEARING PRESSURE OF 2,000 PSF IS ASSUMED.
 - 14 GA FRAMING: 2-1/2" x 2-1/2" TUBE STEEL (TS) WITH 2-1/4" x 2-1/4" TS NIPPLES.
12 GA FRAMING: 2-1/4" x 2-1/4" TS WITH 2" x 2" TS NIPPLES.

THIS IS TO CERTIFY THAT THE CALCULATIONS AND SPECIFICATIONS HEREIN HAVE BEEN PREPARED BY THE UNDERSIGNED PROFESSIONAL ENGINEER, AND ARE IN ACCORDANCE WITH THE REQUIREMENTS OF SECTION 1609 OF THE FLORIDA BUILDING CODE, EIGHTH EDITION (2023).

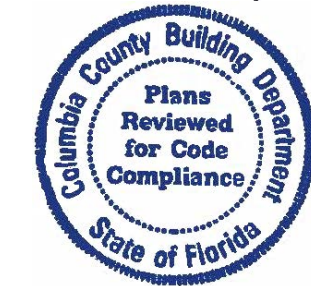

BECHTOL ENGINEERING AND TESTING, INC.
605 WEST NEW YORK AVENUE
DELAND, FLORIDA 32720

NO. 90753
STATE OF FLORIDA
PROFESSIONAL ENGINEER

LOVE B PATEL

CAROLINA CARPORTS, INC.
GENERIC PLANS FOR USE IN THE STATE OF FLORIDA

REVISED: 2/5/2024	DATE: 1/11/2024
DRAWN: MKB / CS	SCALE: NTS
CHECKED: TB / CS	PROJ NO: G24001
APPROVED: TB / LP	SHEET 1 OF 6

BECHTOL ENGINEERING AND TESTING, INC.
CONSULTING GEOTECHNICAL, ENVIRONMENTAL, AND MATERIALS TESTING ENGINEERS
Certificate of Authorization No. 00005492

BOW FRAME RAFTER OPEN CARPORT - HORIZONTAL ROOF

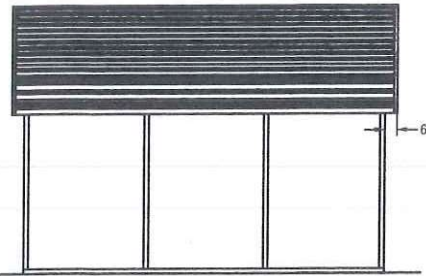

TYPICAL SIDE ELEVATION
NOT TO SCALE

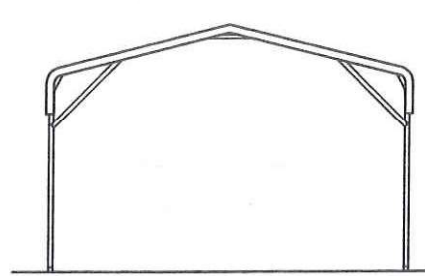

TYPICAL END ELEVATION
NOT TO SCALE

BOW FRAME RAFTER ENCLOSED BUILDING - HORIZONTAL ROOF

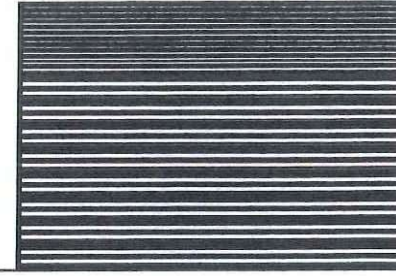

TYPICAL SIDE ELEVATION
NOT TO SCALE

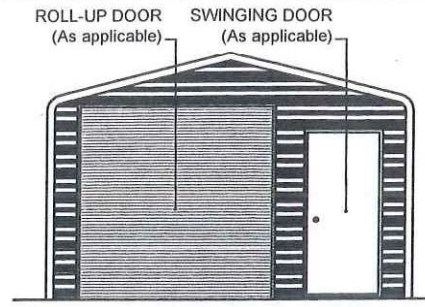

TYPICAL END ELEVATION
NOT TO SCALE

BOW FRAME RAFTER UTILITY BUILDING - HORIZONTAL ROOF

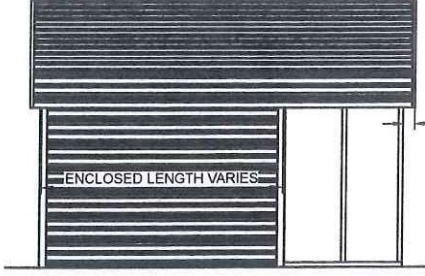

TYPICAL SIDE ELEVATION
NOT TO SCALE

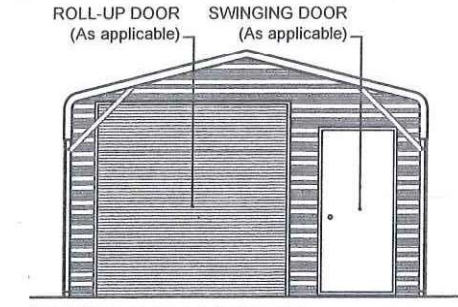

TYPICAL END ELEVATION
NOT TO SCALE

BOX EAVE FRAME RAFTER OPEN CARPORT - HORIZONTAL ROOF

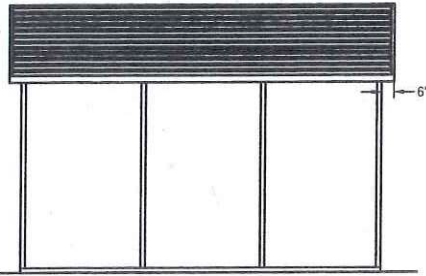

TYPICAL SIDE ELEVATION
NOT TO SCALE

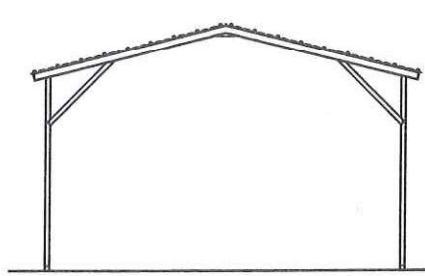

TYPICAL END ELEVATION
NOT TO SCALE

BOX EAVE FRAME RAFTER ENCLOSED BLDG - HORIZONTAL ROOF

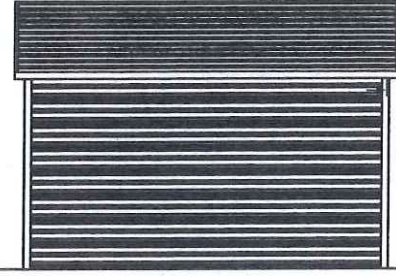

TYPICAL SIDE ELEVATION
NOT TO SCALE

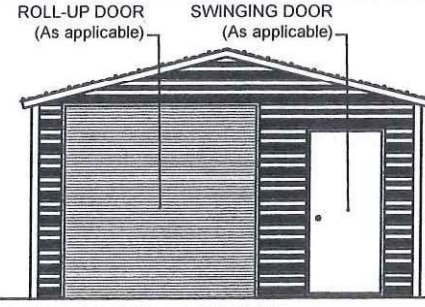

TYPICAL END ELEVATION
NOT TO SCALE

BOX EAVE FRAME RAFTER UTILITY BLDG - HORIZONTAL ROOF

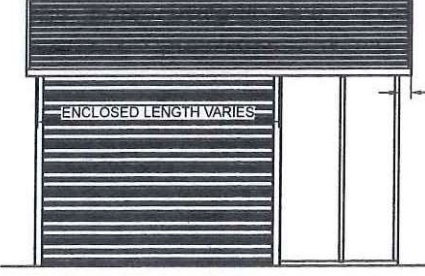

TYPICAL SIDE ELEVATION
NOT TO SCALE

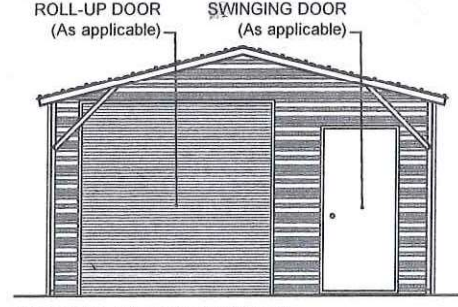

TYPICAL END ELEVATION
NOT TO SCALE

BOX EAVE FRAME RAFTER OPEN CARPORT - VERTICAL ROOF

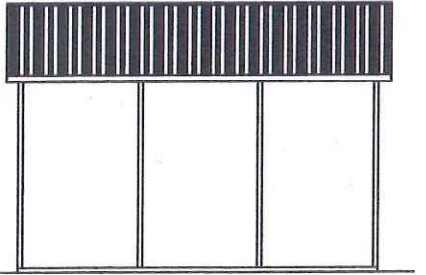

TYPICAL SIDE ELEVATION
NOT TO SCALE

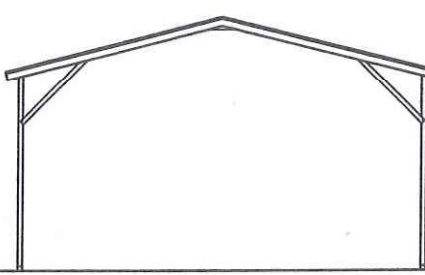

TYPICAL END ELEVATION
NOT TO SCALE

BOX EAVE FRAME RAFTER ENCLOSED BLDG - VERTICAL ROOF

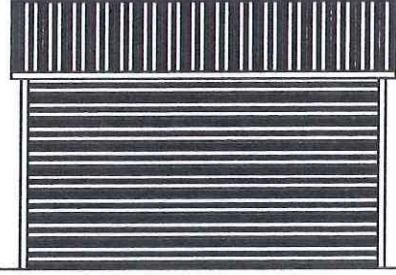

TYPICAL SIDE ELEVATION
NOT TO SCALE

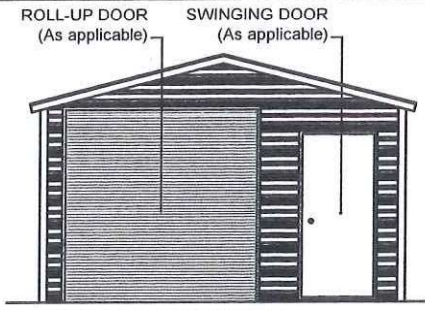

TYPICAL END ELEVATION
NOT TO SCALE

BOX EAVE FRAME RAFTER UTILITY BLDG - VERTICAL ROOF

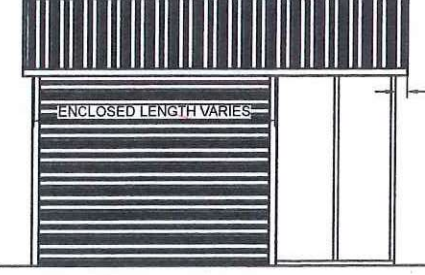

TYPICAL SIDE ELEVATION
NOT TO SCALE

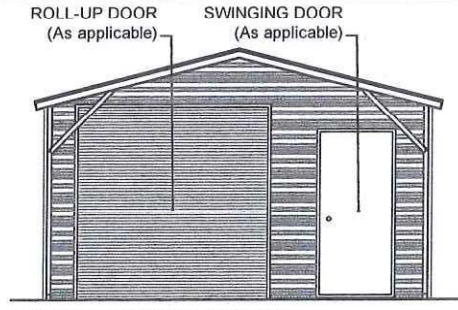

TYPICAL END ELEVATION
NOT TO SCALE

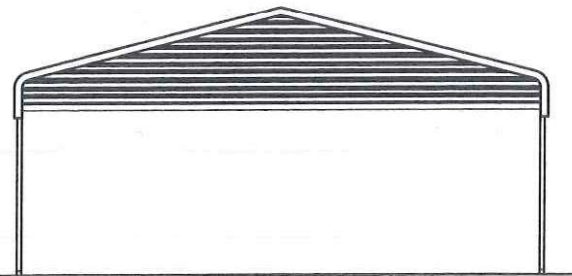

TYPICAL BOW RAFTER GABLE END ELEVATION
NOT TO SCALE

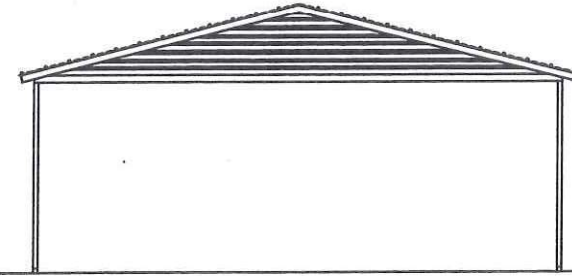

TYPICAL BOX EAVE RAFTER GABLE END ELEVATION
HORIZONTAL ROOF
NOT TO SCALE

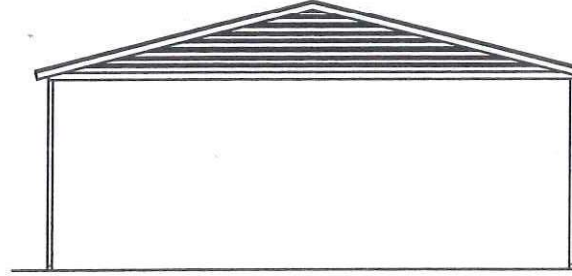

TYPICAL BOX EAVE RAFTER GABLE END ELEVATION
VERTICAL ROOF
NOT TO SCALE

BECHTOL ENGINEERING AND TESTING, INC. No. 90753
605 WEST NEW YORK AVENUE
DELAND, FLORIDA 32720

LOVE B PATEL
LICENSE
STATE OF FLORIDA
PROFESSIONAL ENGINEER

CAROLINA CARPORTS, INC.
GENERIC PLANS FOR USE IN THE STATE OF FLORIDA

REVISION	2/5/2024	DATE	1/1/2024
DRAWN	MKB / CS	SCALE	NTS
CHECKED	TB / CS	PROJ. NO.	G24001
APPROVED	TB / LP	SHEET 2 OF 6	

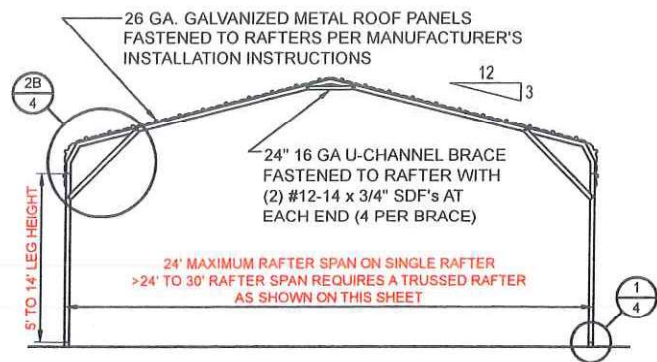

TYPICAL INTERIOR RAFTER/POST FRAME SECTION - BOW FRAME
NOT TO SCALE

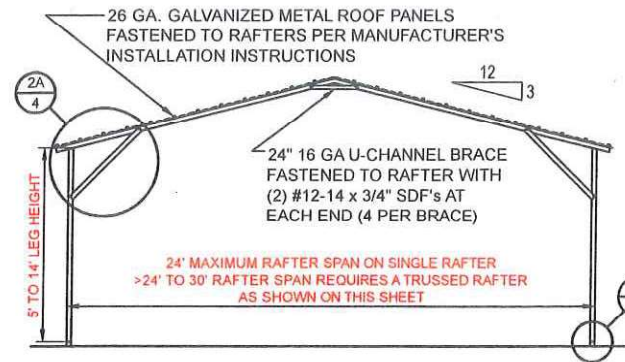

TYPICAL INTERIOR RAFTER/POST FRAME SECTION - HORIZONTAL ROOF - BOX EAVE
NOT TO SCALE

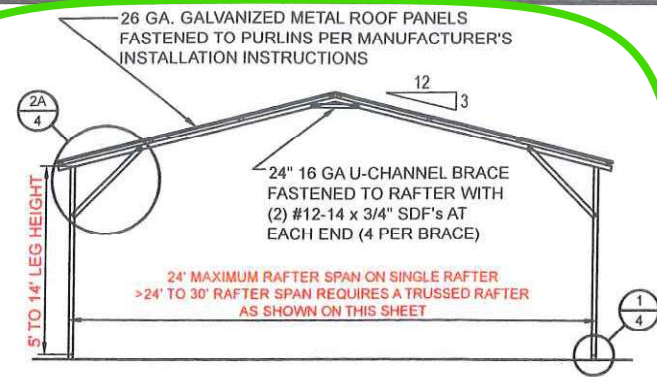

TYPICAL INTERIOR RAFTER/POST FRAME SECTION - VERTICAL ROOF
NOT TO SCALE

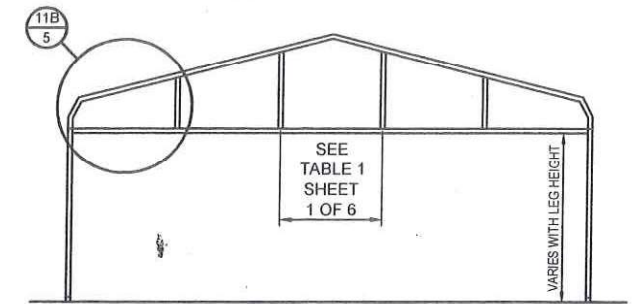

TYPICAL BOW RAFTER GABLE END FRAMING PLAN
NOT TO SCALE

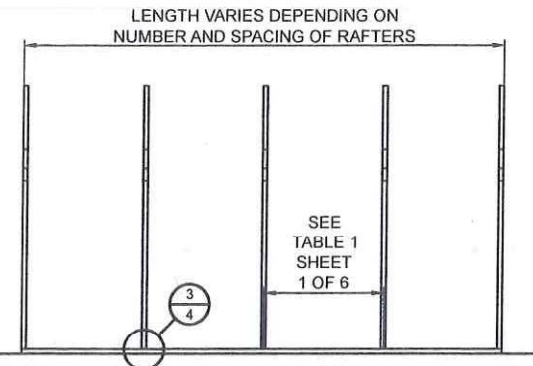

TYPICAL RAFTER/POST FRAMING PLAN - BOW FRAME
NOT TO SCALE

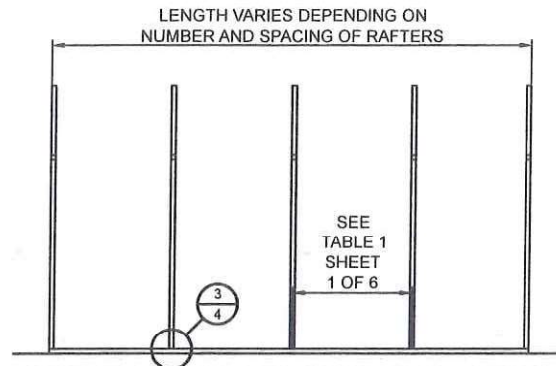

TYPICAL RAFTER/POST FRAMING PLAN - BOX EAVE
NOT TO SCALE

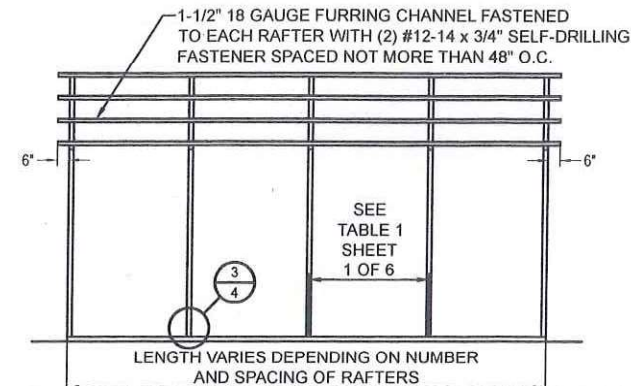

TYPICAL POST/RAFTER FRAMING PLAN - VERTICAL ROOF
NOT TO SCALE

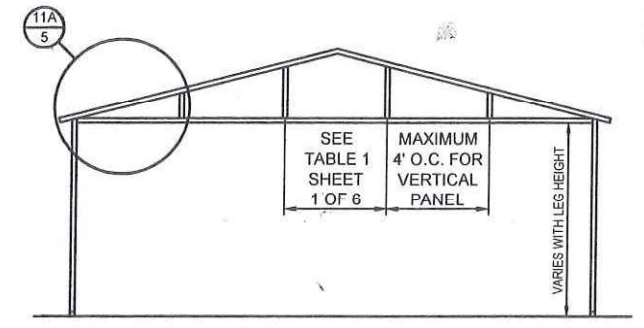

TYPICAL BOX EAVE RAFTER GABLE END FRAMING PLAN
NOT TO SCALE

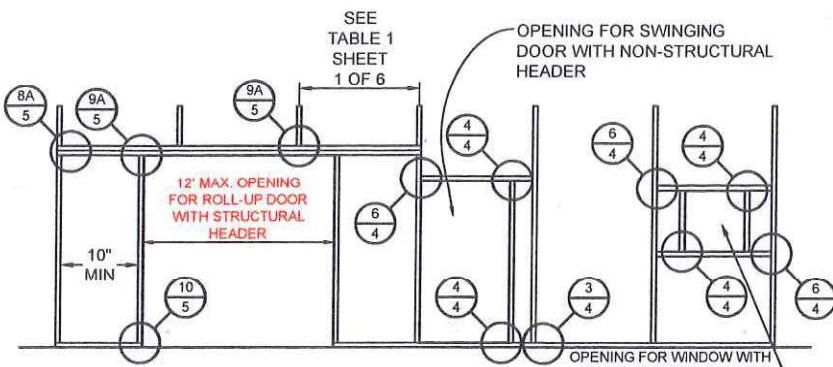

TYPICAL SIDE WALL OPENINGS FRAMING PLAN
NOT TO SCALE

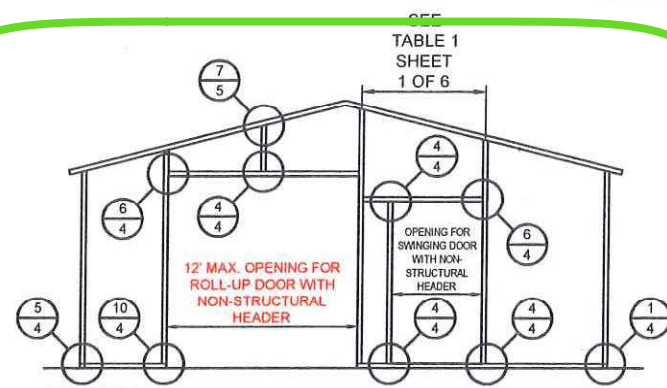

TYPICAL END WALL OPENINGS POST/RAFTER FRAMING PLAN
NOT TO SCALE

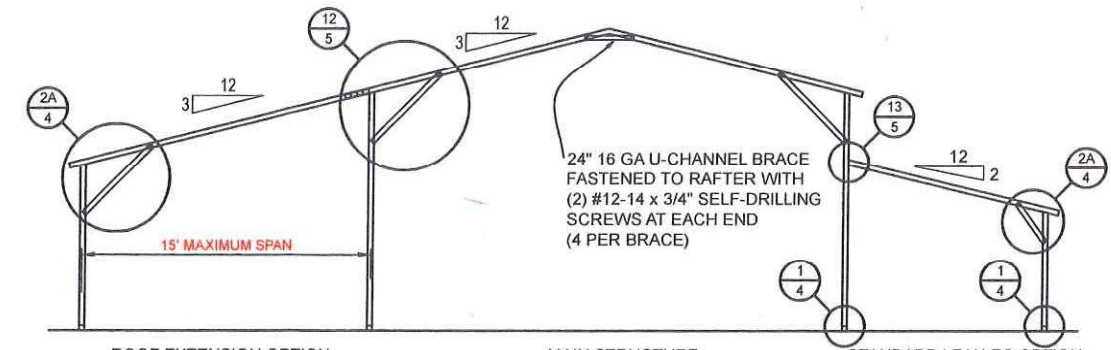

TYPICAL LEAN-TO OPTIONS FRAMING PLAN (BOTH OPTIONS SHOWN)
NOT TO SCALE (BOX EAVE RAFTER SHOWN, ONLY STANDARD LEAN-TO IS APPLICABLE TO BOW FRAME RAFTER)

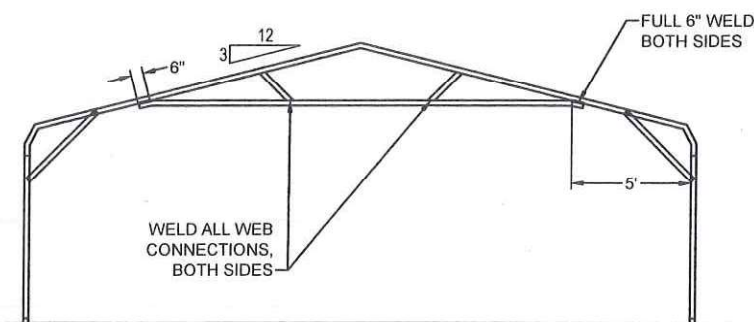

OPTIONAL 24'-1" TO 30' TRUSSED RAFTER - BOW
NOT TO SCALE

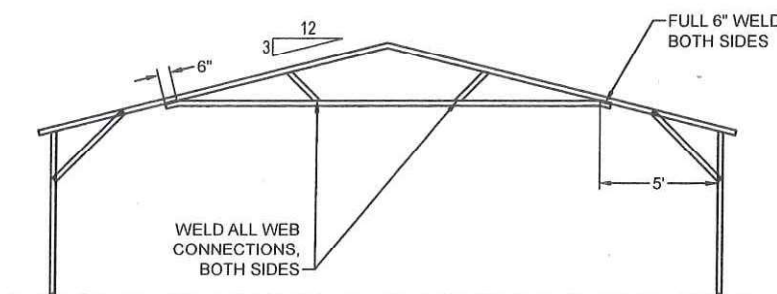

OPTIONAL 24'-1" TO 30' TRUSSED RAFTER - BOX EAVE
NOT TO SCALE

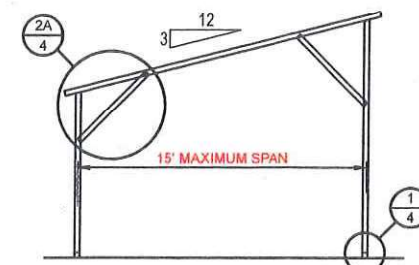

FREESTANDING LEAN-TO FRAMING PLAN
NOT TO SCALE

BECHTOL ENGINEERING AND TESTING, INC.
605 WEST NEW YORK AVENUE
DELAND, FLORIDA 32720

LOVE B PATEL
LICENSE
No. 90753
STATE OF FLORIDA
PROFESSIONAL ENGINEER

CAROLINA CARPORTS, INC.
GENERIC PLANS FOR USE IN THE STATE OF FLORIDA

BECHTOL ENGINEERING AND TESTING, Inc.
CONSULTING GEOTECHNICAL, ENVIRONMENTAL, AND MATERIALS TESTING ENGINEERS
Certificate of Authorization No. 00005192

REVISED:	2/5/2024	DATE:	1/1/2024
DRAWN:	MKB / CS	SCALE:	NTS
CHECKED:	TB / CS	PROJ. NO.:	G24001
APPROVED:	TB / LP	SHEET:	3 OF 6

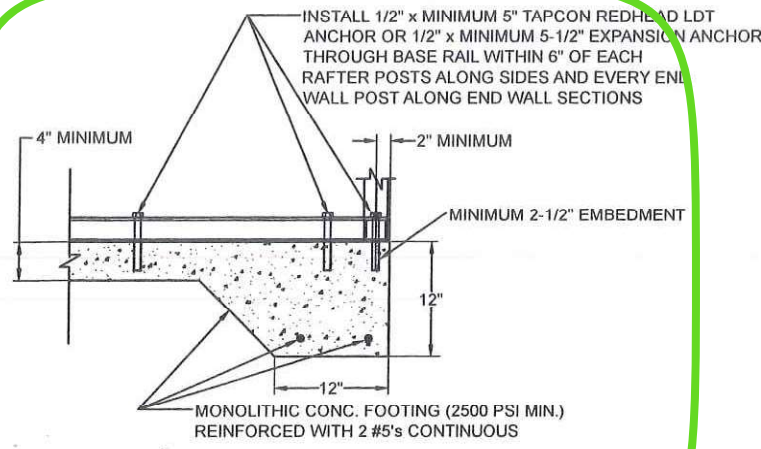

1A CONCRETE BASE RAIL ANCHORAGE
Not To Scale

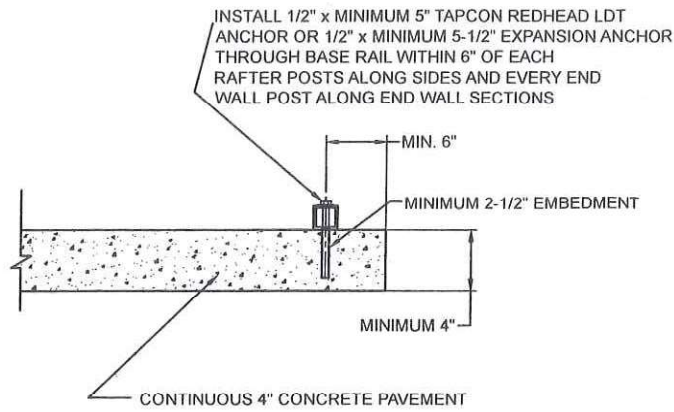

1B CONCRETE BASE RAIL ANCHORAGE
Not To Scale (OPTIONAL - OPEN CARPORTS ONLY)

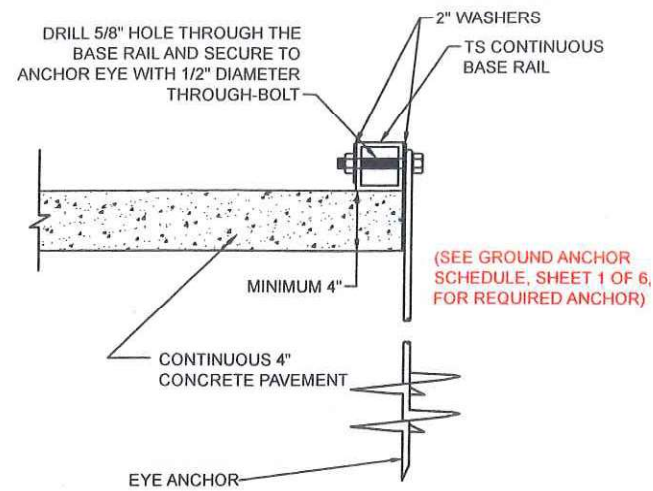

1C CONCRETE BASE RAIL ANCHORAGE
Not To Scale (OPEN CARPORTS WHERE SLAB EDGE DISTANCE DOES NOT MEET MINIMUM EDGE DISTANCE SHOWN IN DETAIL 1B)

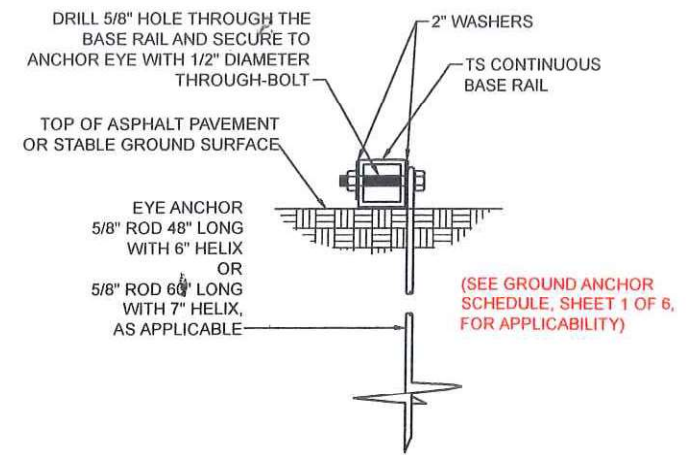

1D BASE RAIL DEEP ANCHORAGE
Not To Scale

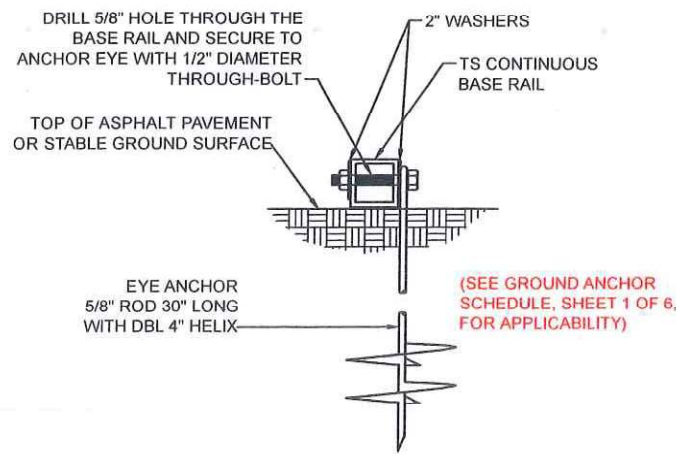

1E BASE RAIL ANCHORAGE
Not To Scale

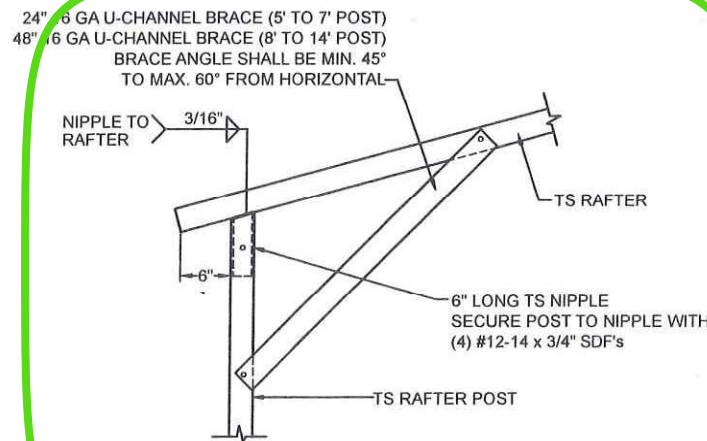

2A BOX EAVE RAFTER/POST DETAIL
Not To Scale

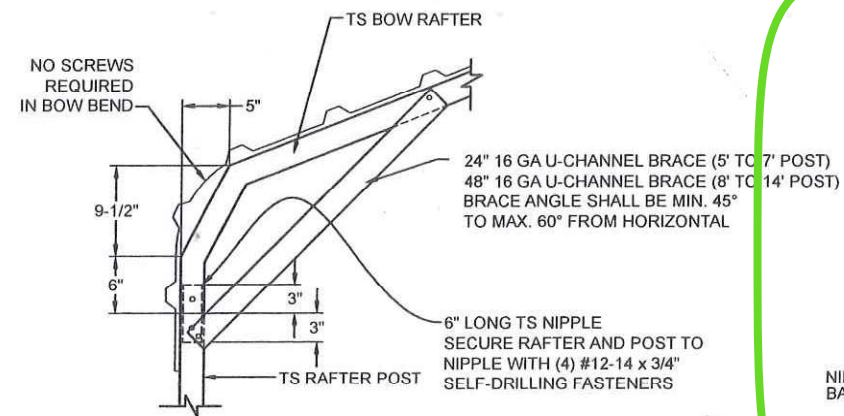

2B BOW RAFTER/POST DETAIL
Not To Scale

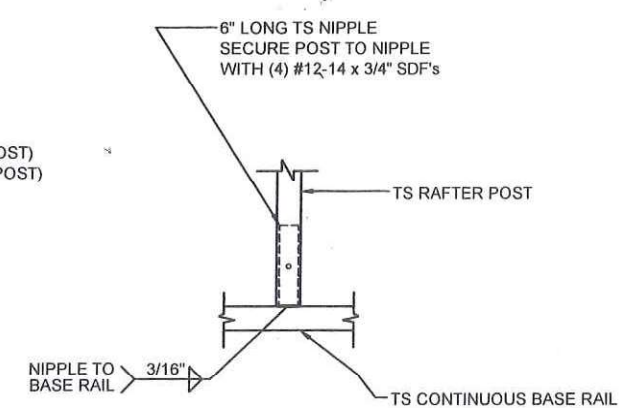

3 POST/BASE RAIL CONN. DETAIL
Not To Scale

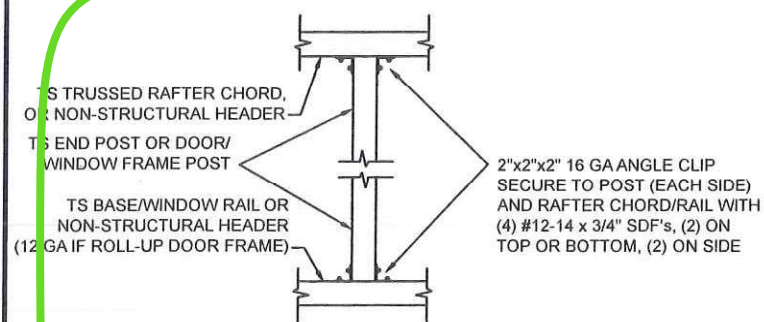

4 POST TO RAIL, TRUSS CHORD, OR NON-STRUCTURAL HEADER CONN. DETAIL
Not To Scale

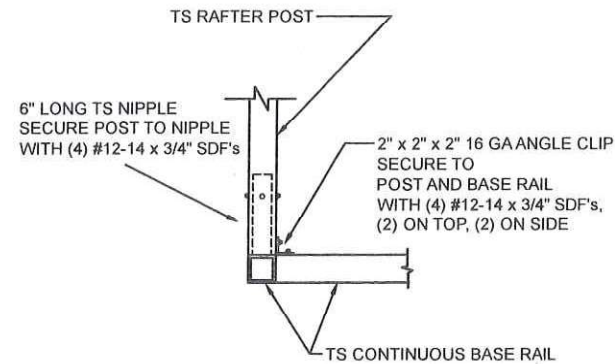

5 END POST/BASE RAIL CONN.
Not To Scale

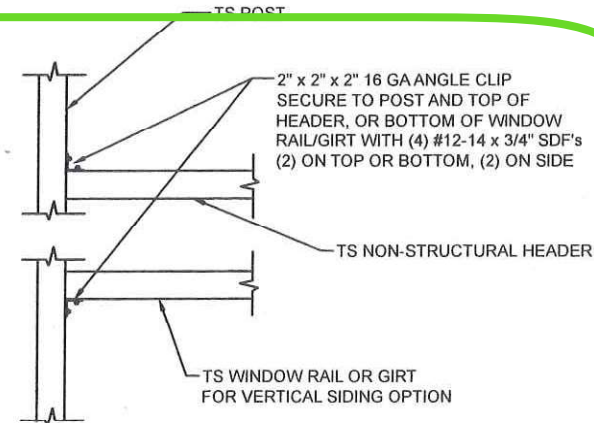

6 NON-STRUCTURAL HEADER, WINDOW RAIL, OR GIRT TO POST CONN. DETAIL
Not To Scale

BECHTOL ENGINEERING AND TESTING, INC.
605 WEST NEW YORK AVENUE
DELAND, FLORIDA 32720

LOVE B PATEL
LICENSE No. 90753
STATE OF FLORIDA
PROFESSIONAL ENGINEER

CAROLINA CARPORTS, INC.
GENERIC PLANS FOR USE IN THE STATE OF FLORIDA

REVISED	2/5/2024	DATE	1/1/2024
DRAWN	MKB / CS	SCALE	NTS
CHECKED	TB / CS	PROJ. NO.	G24001
APPROVED	TB / LP	SHEET	4 OF 6

BECHTOL ENGINEERING AND TESTING, Inc.
CONSULTING GEOTECHNICAL, ENVIRONMENTAL, AND MATERIALS TESTING ENGINEERS
Certificate of Authorization No. 00006192

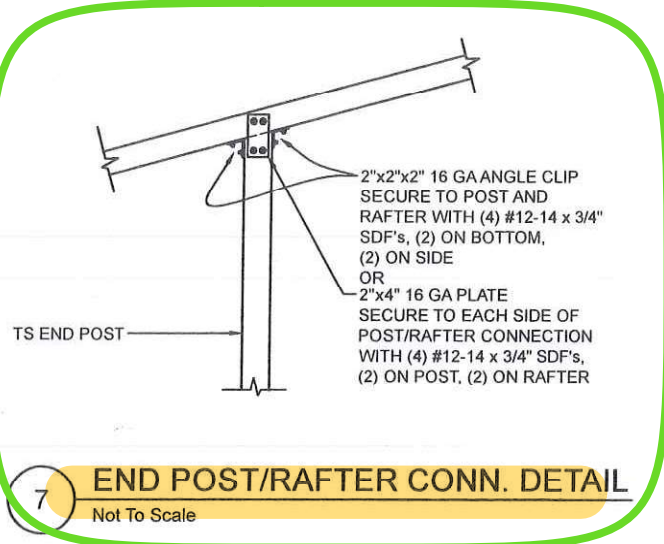

7 END POST/RAFTER CONN. DETAIL
Not To Scale

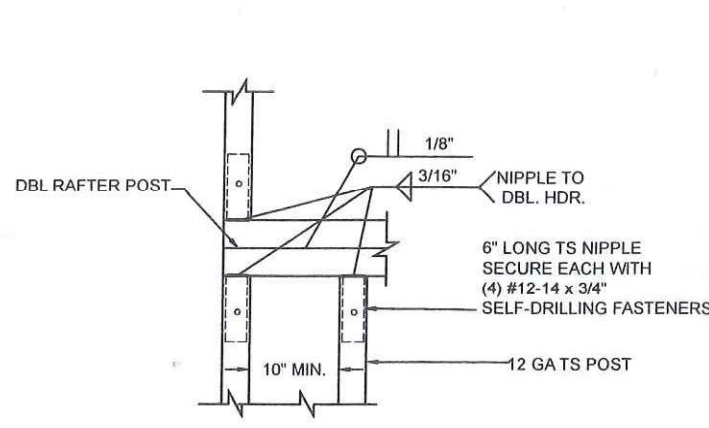

8A RAFTER POST/DBL. HEADER DETAIL
Not To Scale

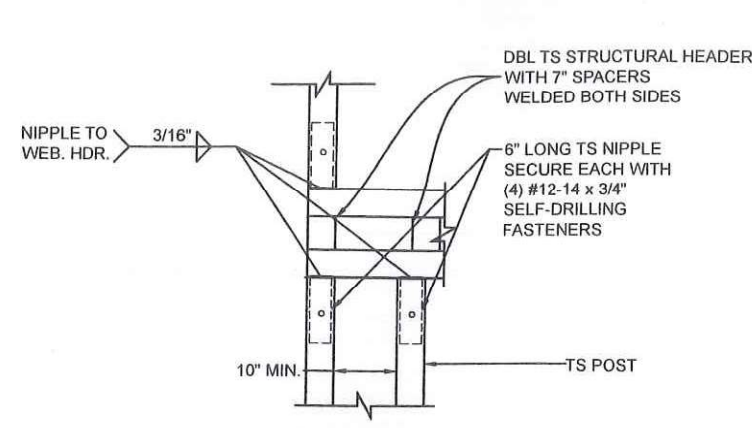

8B RAFTER POST/WEB HEADER DETAIL
Not To Scale

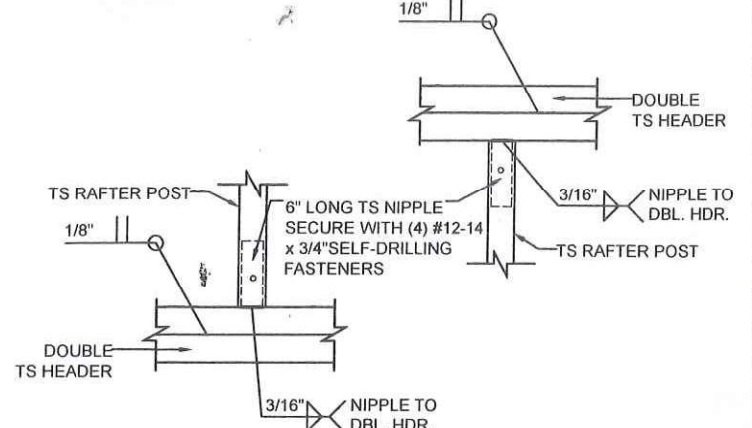

9A RAFTER POST/HEADER DETAIL
Not To Scale

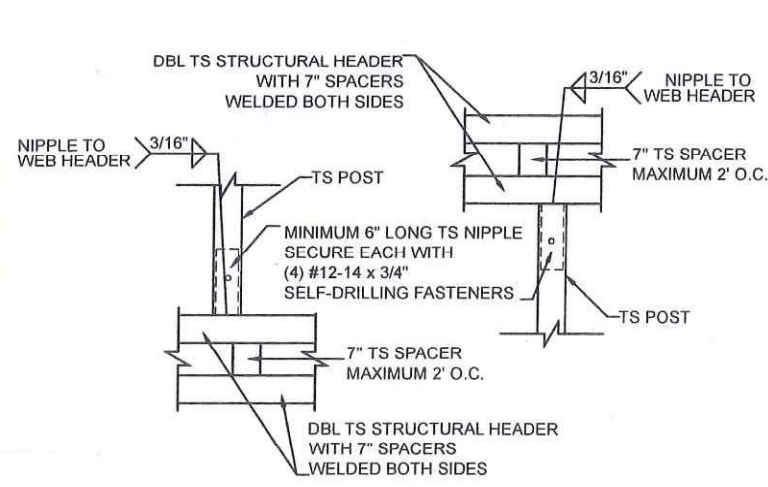

9B STRUCTURAL HEADER TO POST CONNECTION DETAIL
Not To Scale

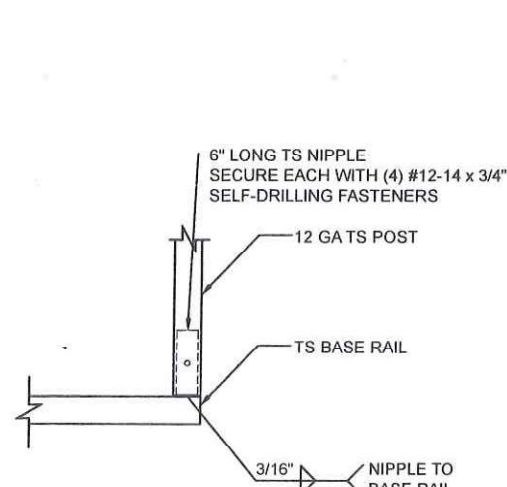

10 FRAMEOUT/ROLL UP POST / BASE RAIL CONN. DETAIL
Not To Scale

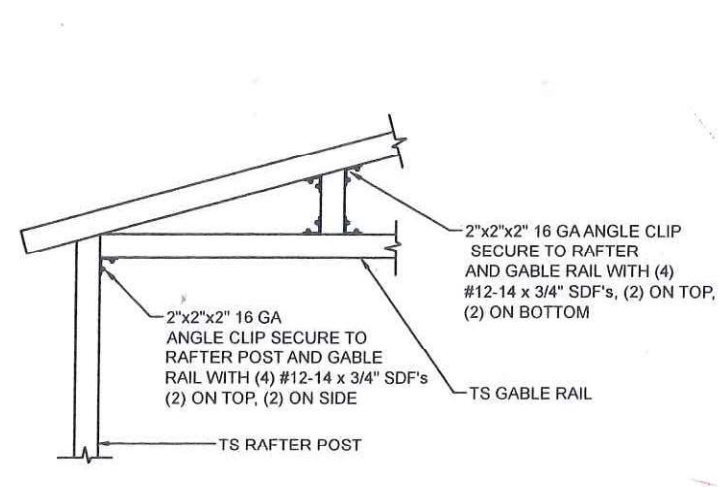

11A GABLE RAIL TO RAFTER POST CONNECTION DETAIL
Not To Scale

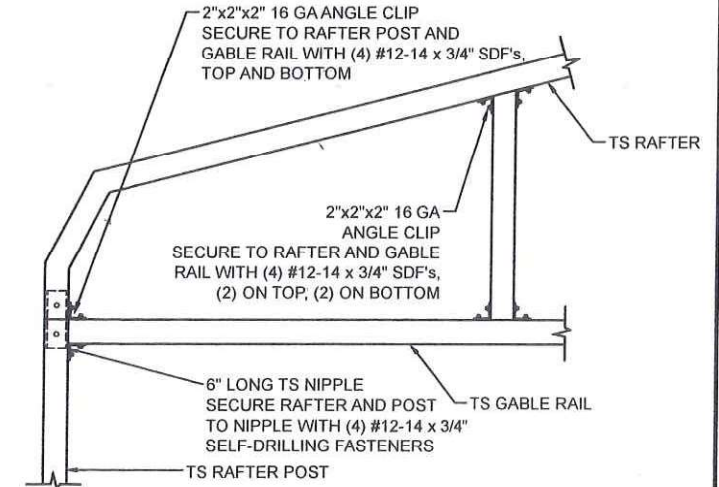

11B GABLE RAIL TO RAFTER POST CONNECTION DETAIL
Not To Scale

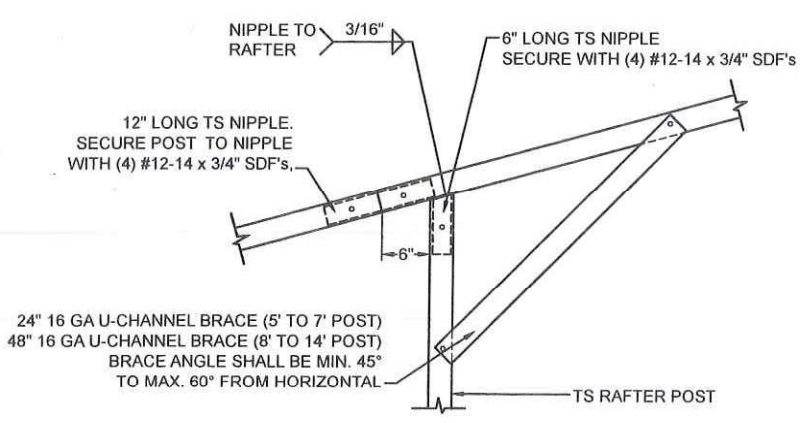

12 SIDE EXTENSION RAFTER/POST DETAIL
Not To Scale

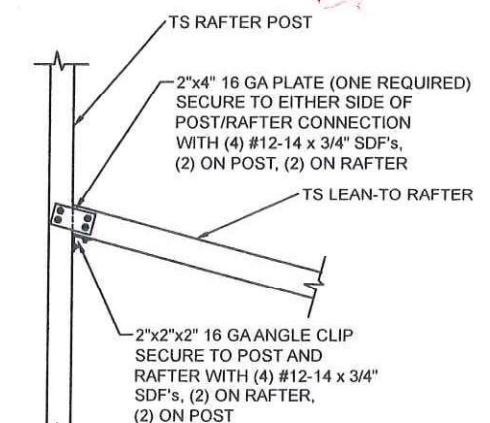

13 POST / LEAN-TO RAFTER CONN. DETAIL
Not To Scale

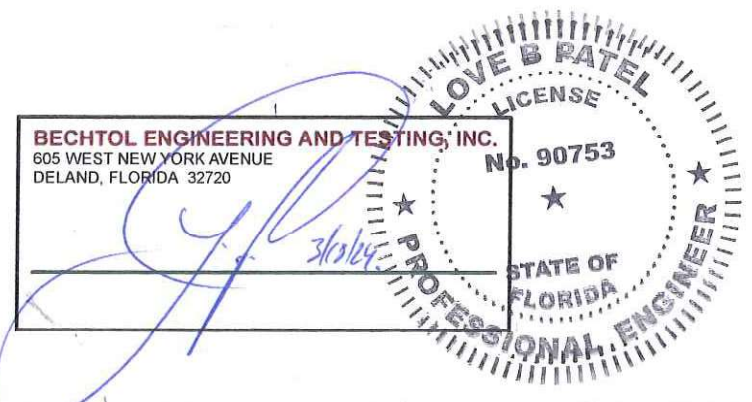

CAROLINA CARPORTS, INC.
GENERIC PLANS FOR USE IN THE STATE OF FLORIDA

REVISED	2/5/2024	DATE	1/1/2024
DRAWN	MKB / CS	SCALE	NTS
CHECKED	TB / CS	PROJ. NO.	G24001
APPROVED	TB / LP		SHEET 5 OF 6

BECHTOL ENGINEERING AND TESTING, INC.
605 WEST NEW YORK AVENUE
DELAND, FLORIDA 32720

BECHTOL ENGINEERING AND TESTING, inc.
CONSULTING GEOTECHNICAL, ENVIRONMENTAL, AND MATERIALS TESTING ENGINEERS
Certificate of Authorization No. 0005492

VERTICAL SIDE OPTION

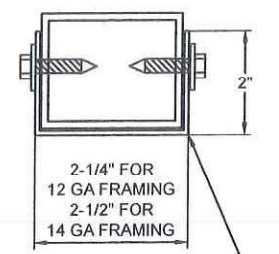

16 GAUGE U-CHANNEL BRACE FASTENED TO THE POST AND RAFTER WITH (2) #12-14 x 3/4\" SDF'S AT EACH END (4 PER BRACE)

BRACE SECTION
Not To Scale

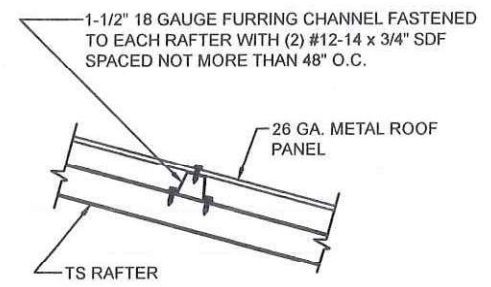

ROOF PANEL ATTACHMENT
(ALTERNATE FOR VERTICAL ROOF PANELS)
Not To Scale

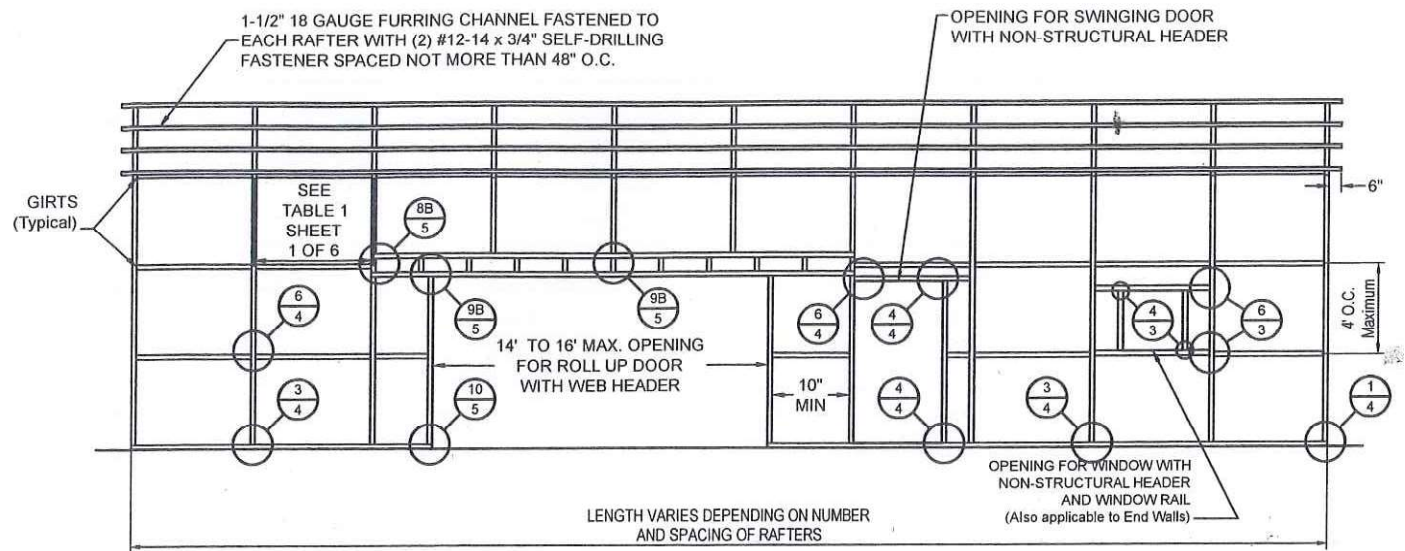

TYPICAL POST/RAFTER/GIRT FRAMING PLAN
NOT TO SCALE

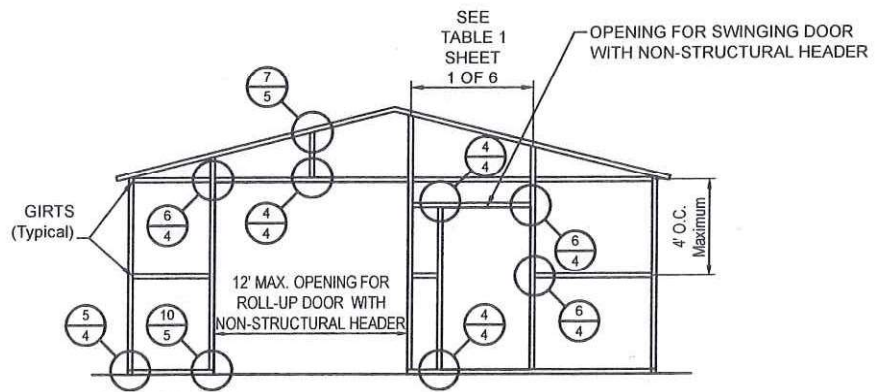

TYPICAL END WALL OPENINGS POST/RAFTER/GIRT FRAMING PLAN
NOT TO SCALE

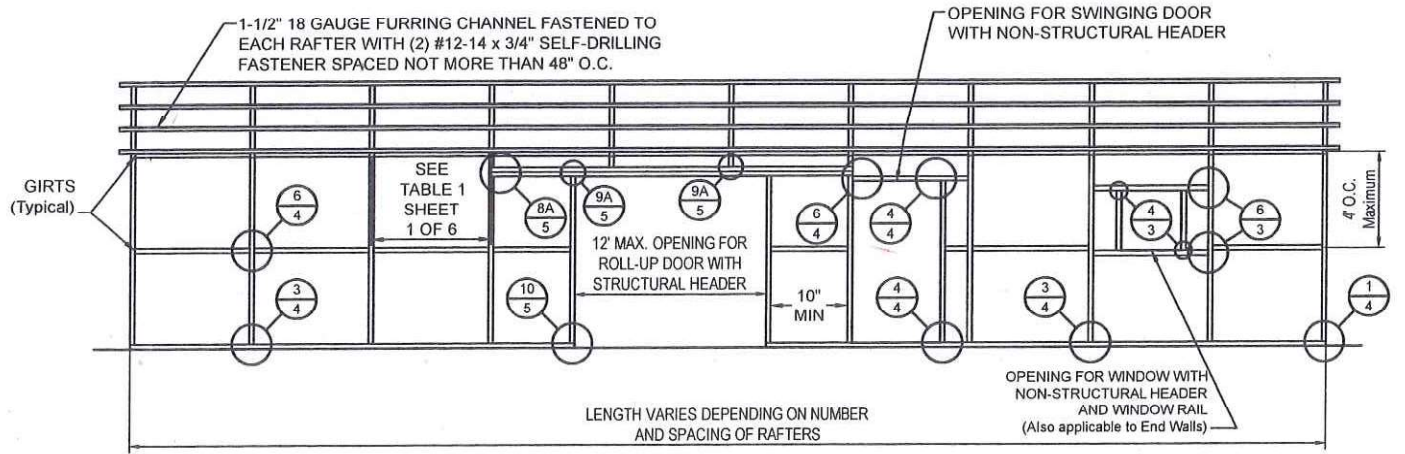

TYPICAL POST/RAFTER/GIRT FRAMING PLAN
NOT TO SCALE

BOX EAVE FRAME RAFTER ENCLOSED BLDG - VERTICAL SIDES

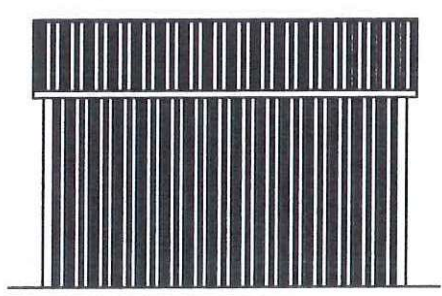

TYPICAL SIDE ELEVATION
NOT TO SCALE

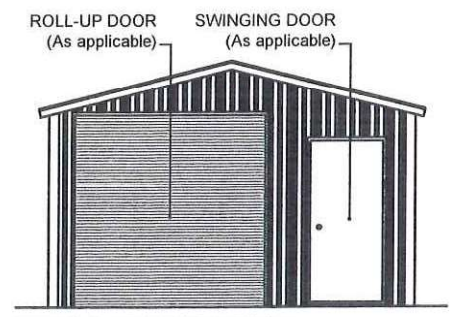

TYPICAL END ELEVATION
NOT TO SCALE

BOX EAVE FRAME RAFTER UTILITY BLDG - VERTICAL SIDES

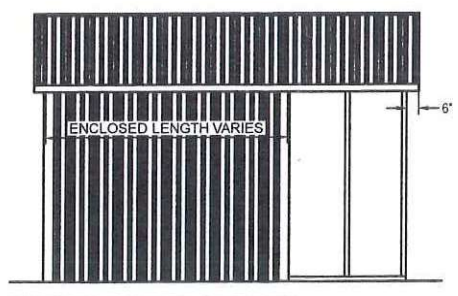

TYPICAL SIDE ELEVATION
NOT TO SCALE

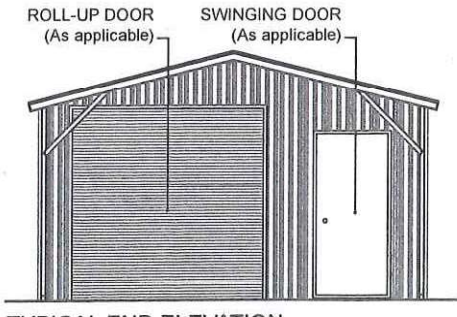

TYPICAL END ELEVATION
NOT TO SCALE

BECHTOL ENGINEERING AND TESTING, INC.
605 WEST NEW YORK AVENUE
DELAND, FLORIDA 32720

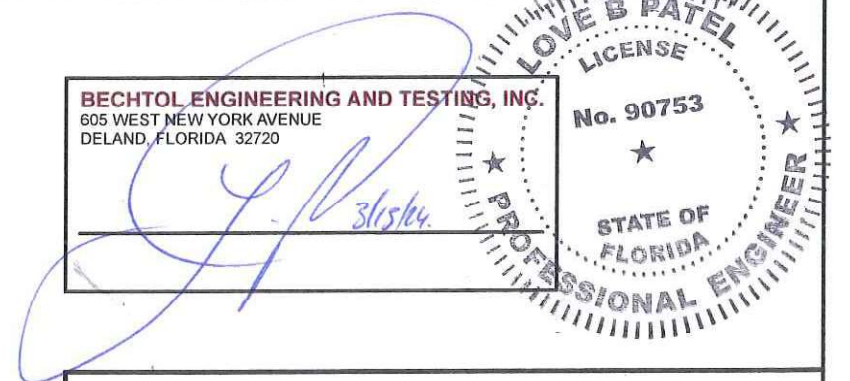

CAROLINA CARPORTS, INC.
GENERIC PLANS FOR USE IN THE STATE OF FLORIDA

REVISED	2/5/2024	DATE	1/1/2024
DRAWN	MKB / CS	SCALE	NTS
CHECKED	TB / CS	PROJ NO.	G24001
APPROVED	TB / LP	SHEET 6 OF 6	

BECHTOL ENGINEERING AND TESTING, Inc.
CONSULTING GEOTECHNICAL, ENVIRONMENTAL, AND MATERIALS TESTING ENGINEERS
Certificate of Authorization No. 00005492