



Custom Home For:  
**DANIEL & MICHELLE STAGG**  
 COLUMBIA FLORIDA, FLORIDA

DRAWING INDEX

S1 SITE PLAN  
 A1 FLOOR PLAN  
 A2 DIMENSION PLAN  
 A3 EXTERIOR ELEVATIONS  
 A4 EXTERIOR ELEVATIONS  
 A5 FOUNDATION PLAN

A6 TYPICAL WALL SECTIONS  
 A7 TYPICAL BUILDING SECTION  
 A8 TYPICAL DETAILS  
 A9 DOOR/WINDOW DETAILS  
 A10 PLUMBING RISER

A11 ROOF FRAMING PLAN  
 A12 OPT. METAL ROOF DETAILS  
 A13 ELECTRICAL PLAN  
 A14 GENERAL NOTES  
 A15 GENERAL NOTES

REVISION:

Copyright 2005  
M.P. Geiser, Architect

DRAWN:  
DJR

Custom Designed Home for:  
**DANIEL & MICHELLE STAGG**  
COLUMBIA COUNTY, FLORIDA  
**5 I T E P L A N**

**ADD**  
ARCHITECTURAL DRAFTING & DESIGN, INC.  
Lake City, FL 32055 - 386.752.4670

**NG**  
NICHOLAS  
PAUL  
GEISLER  
ARCHITECT  
N.C.A.R.C.B. Certified  
1725 NW Brown Rd.  
Lake City, FL 32055  
386-753-3921

DATE:  
20NOV2007

COMM:

SHEET:  
**S1**  
1 OF 1

*M.P. Geiser*  
03 Dec 2007  
AR0007005

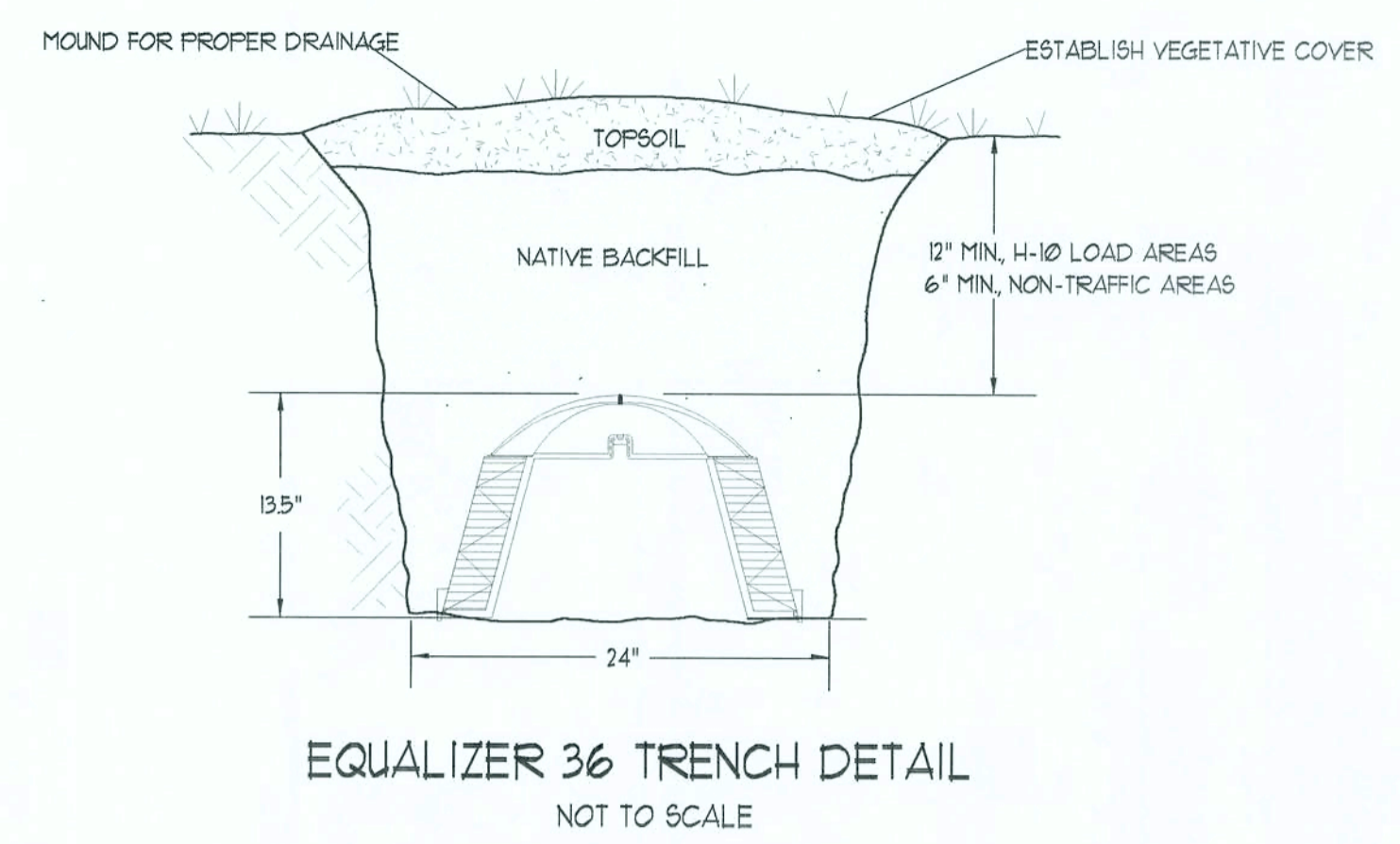
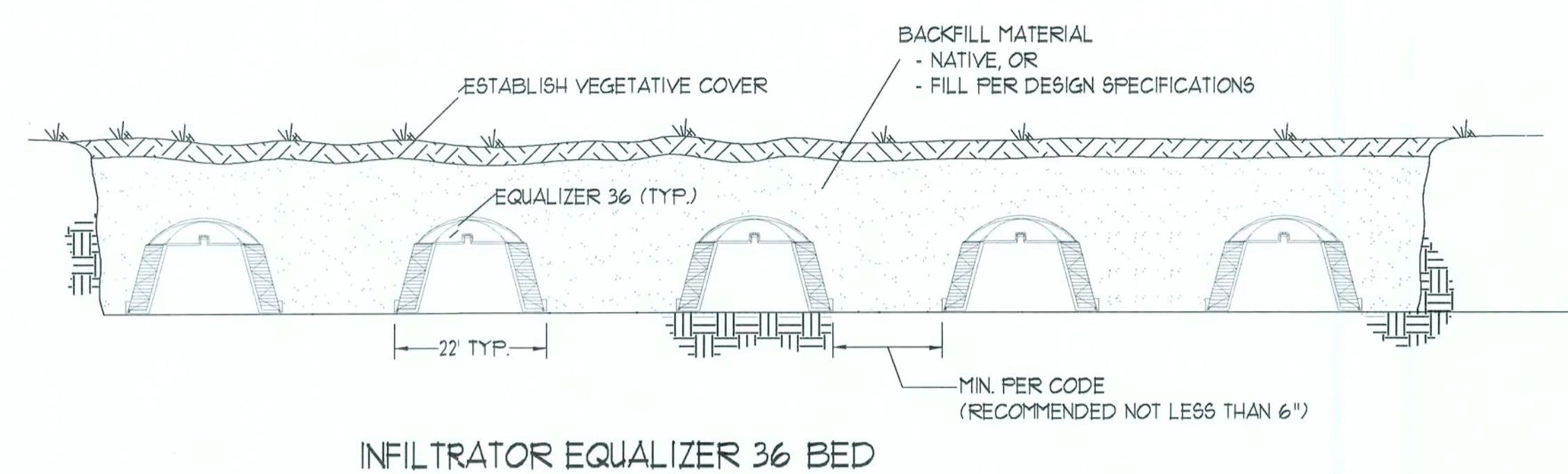

- GENERAL WELL & SEPTIC NOTES:**
- SUB-CONTRACTORS PROVIDING WATER WELLS AND/OR SEPTIC TANKS AND DRAINFIELDS SHALL BE SUBJECT TO THE PROVISIONS OF NOTES 1 THRU 6, THIS SHEET
  - LOCATION OF POTABLE WATER WELLS SHALL BE DETERMINED BY THE OWNER IN CONSULTATION WITH THE WELL DRILLING CONTRACTOR. WELLS SHALL NOT BE LOCATED CLOSER THAN 15'-0" TO ANY PROPOSED OR EXISTING SEPTIC TANK OR DRAINFIELD, EITHER ON SUBJECT PROPERTY OR ADJACENT/ADJOINING PROPERTY.
  - POTABLE WATER WELLS SHALL BE A MINIMUM 4"Ø WITH BLACK IRON CASING TO A DEPTH OF 80'-0". PUMPS SHALL BE OF THE SUBMERSIBLE TYPE, THREE WIRE SYSTEM, MINIMUM HORSEPOWER SHALL BE 1/2 H/P OR AS DIRECTED BY THE OWNER. MOTOR STARTER SHALL BE ENCLOSED IN A WEATHERPROOF HOUSING, MOUNTED ON A P/T 4X4 POST AT THE WELL HEAD.
  - WELL HEAD SHALL PROJECT 12" ABOVE GRADE.
  - ALL REQUIRED COMPONENTS FOR A COMPLETE OPERATING SYSTEM SHALL BE PROVIDED, INCLUDING ANTI-FREEZE BLEEDER FITTING, CHECKVALVE, AIR BLEEDERS, SHUTOFF VALVE, HOSE BIBB, PRESSURE REGULATOR/CONTACTOR, UNIONS AND PRESSURE GAUGE.
  - PRESSURE TANK SHALL BE GALVANIZED 82 GALLON CAPACITY, UNLESS DIRECTED OTHERWISE BY THE OWNER.
  - SEPTIC TANK LOCATION & DRAINFIELD INVERT SHALL BE DETERMINED BY THE LOCAL HEALTH DEPARTMENT, IN CONSULTATION W/ THE OWNER.
  - SEPTIC TANKS SHALL BE OF A SIZE & CONSTRUCTION AS DETERMINED BY THE LOCAL HEALTH DEPARTMENT. TANK MAT'L SHALL BE POURED CONCRETE OR FIBERGLASS AS ALLOWED BY THE SEPTIC TANK PERMIT.
  - SEPTIC DRAINFIELDS SHALL BE CONSTRUCTED TO THE STANDARDS OF THE LOCAL HEALTH DEPARTMENT.
  - SAND FILTER BEADS, MOUND SYSTEMS, DOSING TANKS, GREASE TRAPS, DISTRIBUTION BOXES, GRINDER PUMPS, SUMP PUMPS AND OTHER SUCH RELATED ITEMS (IF REQUIRED OR REQUESTED) SHALL BE AS PER THE DESIGN STANDARDS OF THE LOCAL HEALTH DEPARTMENT.

**LEGAL DESCRIPTION:**  
TRACT 3 A.C. MILTON TOWNSHIP 5 SOUTH, RANGE 11 EAST, SECTION 29 AND 32: A PART OF THE SOUTH 1/2 OF SECTION 29 AND A PART OF THE NORTH 1/2 OF SECTION 32 ALL IN TOWNSHIP 5 SOUTH, RANGE 11 EAST MORE PARTICULARLY DESCRIBED AS FOLLOWS:  
COMMENCE AT THE SOUTHEAST CORNER OF THE SW 1/4 OF SAID SECTION 29 AND RUN S 89°29'42" W ALONG THE SOUTH LINE, THEREOF, 411.62 FEET FOR A POINT OF BEGINNING, THENCE N 00°03'11" E, 592.06 FEET; THENCE N 89°39'12" E, 631.95 FEET; THENCE S 11°01'58" E, 5639.19 FEET; THENCE S 89°39'12" W, 155.05 FEET; THENCE N 00°11'11" E, 38.65 FEET TO THE POINT OF BEGINNING.  
COLUMBIA COUNTY, FLORIDA  
CONTAINING 10.01 ACRES MORE OR LESS,  
GRANTOR RESERVES A PERPETUAL NON-EXCLUSIVE INGRESS-EGRESS EASEMENT OVER AND ACROSS THE WEST 40 FEET OF THE FOREGOING DESCRIBED LANDS.

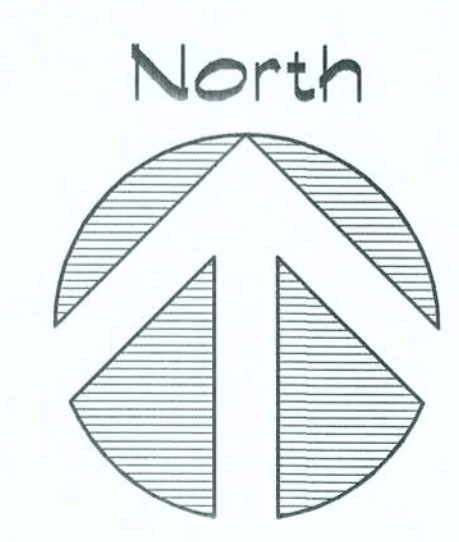
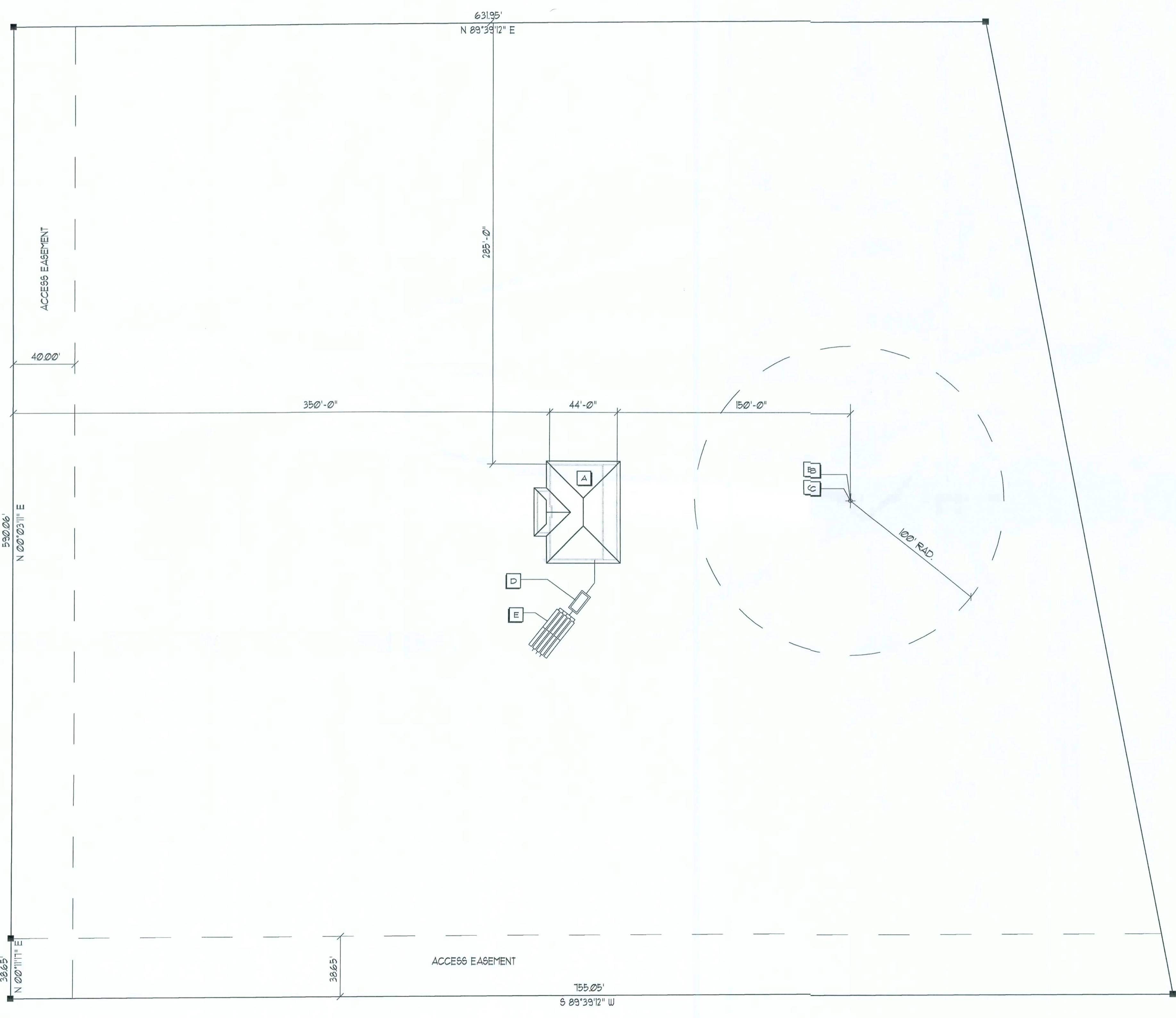

Site PLAN

SCALE: 1" = 40.0'

- PLAN NOTES**
- A** NEW 2941 SF. RESIDENCE INCLUDING: (2) COVERED PORCHES
  - B** EXISTING 4" WELL - W/HP SUBMERSIBLE PUMP
  - C** 80 GAL. PRESSURE TANK & CYCLE STOP VALVE
  - D** PROPOSED SEPTIC TANK SYSTEM, SIZED PER SEPTIC TANK PERMIT REQUIREMENTS
  - E** PROPOSED INFILTRATOR LEACHFIELD SYSTEM, SIZED PER SEPTIC TANK PERMIT REQUIREMENTS

These drawings, as instruments of service, are the sole property of the architect, and may not be used, copied or reproduced in whole or in part for use on or incorporated into any other job without specific and individual authorization by the architect.

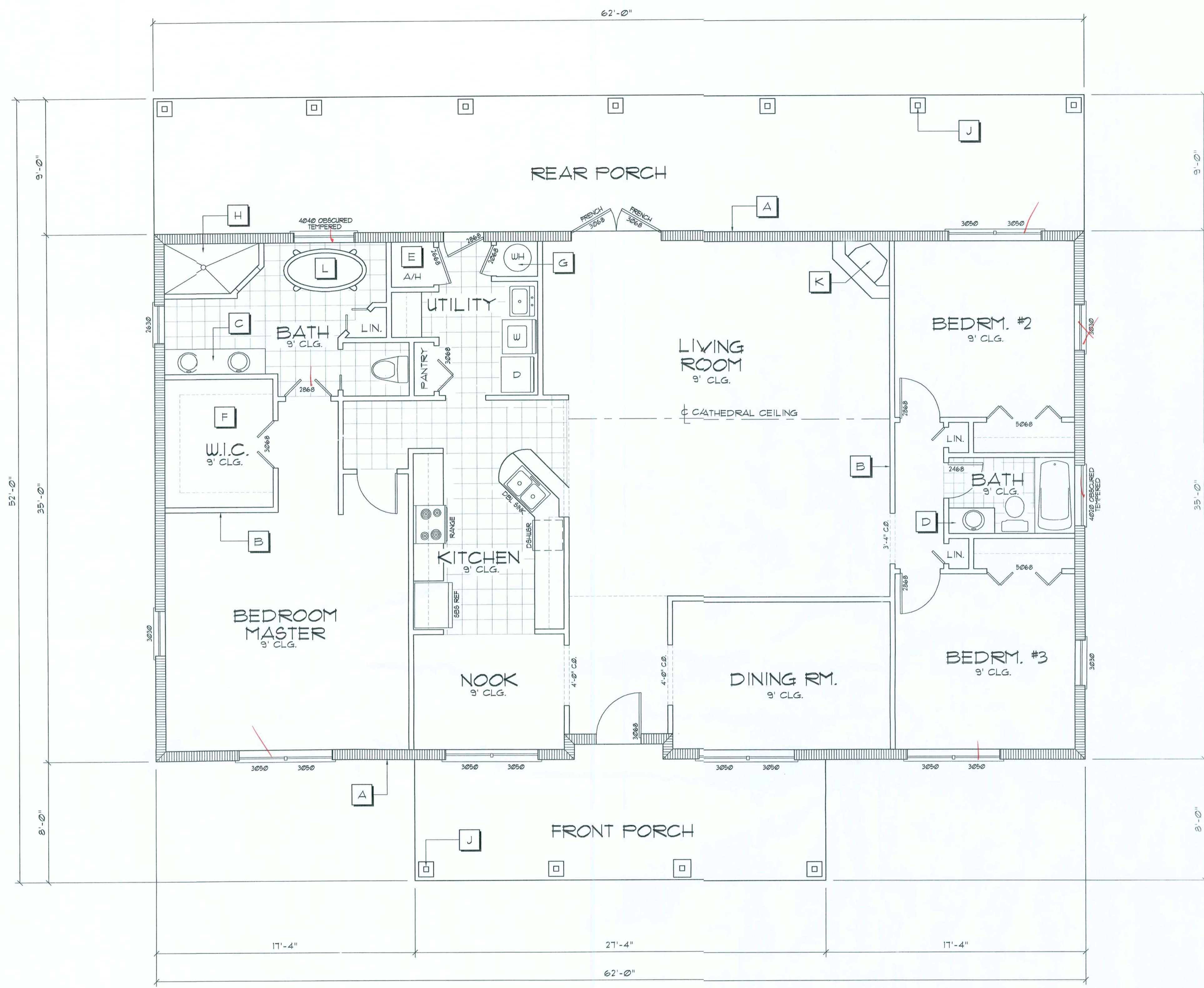

**Floor PLAN**  
SCALE: 1/4" = 1'-0"

**Plan Notes**

- A 8" CONCRETE BLOCK WALL
- B 2X4 Nr. 2 FIR STUDS @ 16" O.C.
- C 12"X20"X30"H VANITY CABINET W/(2) LAVATORIES
- D 30"X20"X30"H VANITY CABINET W/(1) LAVATORY
- E HVAC / AIR HANDLER
- F WALK-IN CLOSET W/SHELF & ROD @ 66" AFF.
- G 50 GAL. ELECTRIC WATER HEATER
- H 40"X76" WALK-IN SHOWER
- J BOXED 3 1/2"X3 1/2"X1/4" STEEL POSTS PER OWNERS SPECS.
- K PREFAB. FIREPLACE INSERT
- L 'BEAR CLAW' TUB

**STRUCTURAL DESIGN DATA**

BASIC WIND SPEED: 110 MPH  
 WIND IMPORTANCE FACTOR (I): 1 = 1.00  
 BUILDING CATEGORY: CATAGORY II  
 WIND EXPOSURE: "B"  
 INTERNAL PRESSURE COEFFICIENT: +/- 0.18  
 MUFRS PER TABLE 1609.2A (FBC 2004) ROOF: - 23.1 P8F  
 DESIGN WIND PRESSURES: WALLS: + 26.6 P8F  
 EAVES: - 32.3 P8F  
 COMPONENTS & CLADDING PER TABLES 1609.2B & 1609.2C (FBC 2004) OPNGS: 21.8 / - 29.1 P8F  
 DESIGN WIND PRESSURES: EAVES: 68.3 P8F  
 ROOF: 19.9 / - 25.5 P8F

**DESIGN CRITERA**

FLORIDA BUILDING CODE  
 FLORIDA FIRE PREVENTION CODE  
 NFPA 101, LIFE SAFETY CODE, FLORIDA EDITION

**2004 FLORIDA BUILDING CODE - COMPLIANCE SUMMARY**

<p>BASIC WIND SPEED: 110 MPH</p> <p>WIND IMPORTANCE FAC'OR (I): 1 = 1.00</p> <p>BUILDING CATEGORY: CATAGORY II</p> <p>WIND EXPOSURE: "B"</p> <p>INTERNAL PRESSURE COEFFICIENT: +/- 0.18</p> <p>MUFRS PER TABLE 1609.2A (FBC 2004) ROOF: - 23.1 P8F                  WALLS: + 26.6 P8F                  EAVES: + 32.3 P8F</p> <p>DESIGN WIND PRESSURES:</p> <p>COMPONENTS &amp; CLADDING PER TABLES 1609.2B &amp; 1609.2C (FBC 2004) OPNGS: + 21.8 / - 29.1 P8F                  EAVES: - 68.3 P8F                  ROOF: + 19.9 / - 25.5 P8F</p>	<p>TYPE OF CONSTRUCTION</p> <p>Roof: Hip Roof Construction, Wood Trusses @ 24" O</p> <p>Walls: 8" CMU Walls - Reinf. per Drawings</p> <p>Floor: 4" Trk Concrete Slab w/ Fibermesh Concrete (Additive)</p> <p>Foundation: Continuous Footer/Stem Wall</p> <p>ROOF DECKING</p> <p>Material: 5/8" CDX Plywood</p> <p>Sheet Size: 48"X36" Sheets Perpendicular to Roof Framing</p> <p>Fasteners: #10 Common Nails @ 12" o.c. Ext. &amp; 6" o.c. Int.</p> <p>SHEARWALLS</p> <p>Material: 8" CMU w/5 Vert. Reinforcing @ 48" o.c.</p>	<p>HURRICANE UPLIFT CONNECTORS</p> <p>Truss to Wall: 'SIMPSON' HETA12® Ea. Truss End</p> <p>Truss to Beam @ Porch: 'SIMPSON' H16® Ea. Truss</p> <p>FOOTINGS AND FOUNDATIONS</p> <p>Footings: 12"X24" W/3 #5 Rebar - continuous</p> <p>Stemwall: 8" CMU with 5 Vert. Reinforcing @ 48" o.c.</p> <p>Stemwall Fiers: 16" SQ. CMU W/4 #5 Vert. Dowels Hooked to Slab Bond Beam</p>
--	---	--

ALL WIND LOADS ARE IN ACCORDANCE WITH SECTION 1609, FLORIDA BUILDING CODE, 2004 EDITION.

**Design Data**

2170 S.F. - LIVING AREA
550 S.F. - REAR PORCH
219 S.F. - FRONT PORCH
<b>2941 S.F. - TOTAL AREA</b>

**Doors / Windows**

**DOOR DESIGNATIONS**

2068 = 24"X80" DOOR
2468 = 28"X80" DOOR
2668 = 30"X80" DOOR
2868 = 32"X80" DOOR
3068 = 36"X80" DOOR

**WINDOW DESIGNATIONS**

2630 = 30"X36" WINDOW
3020 = 36"X24" WINDOW
3046 = 36"X54" WINDOW
3050 = 36"X60" WINDOW
3060 = 36"X72" WINDOW
4040 = 48"X48" WINDOW
4060 = 48"X72" WINDOW

These drawings, or instruments of service, are the sole property of the architect, and may not be used, copied or reproduced in whole or in part for use on or incorporated within any other job without specific and individual authorization by the architect.

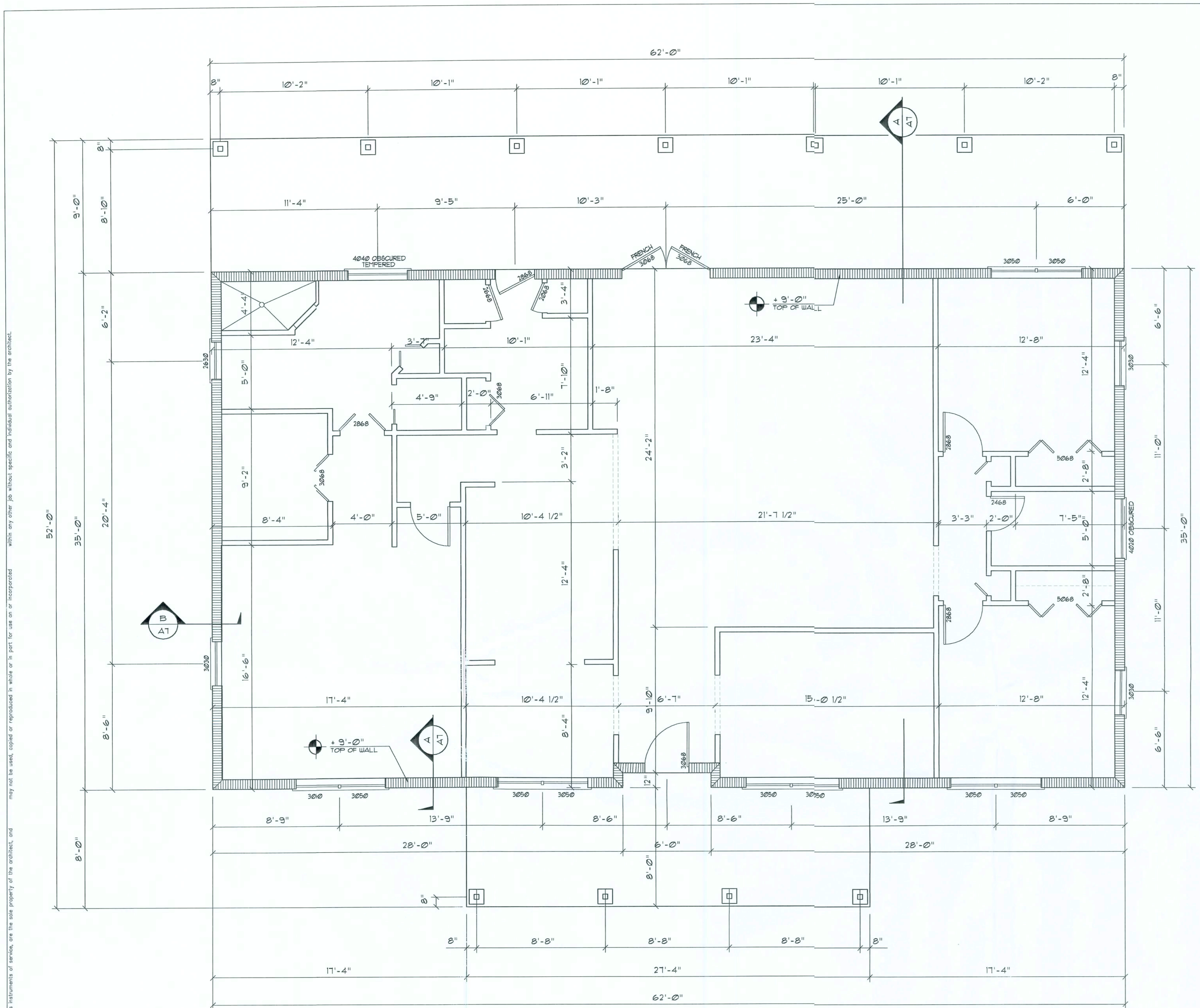

**Dimension PLAN**

SCALE: 1/4" = 1'-0"

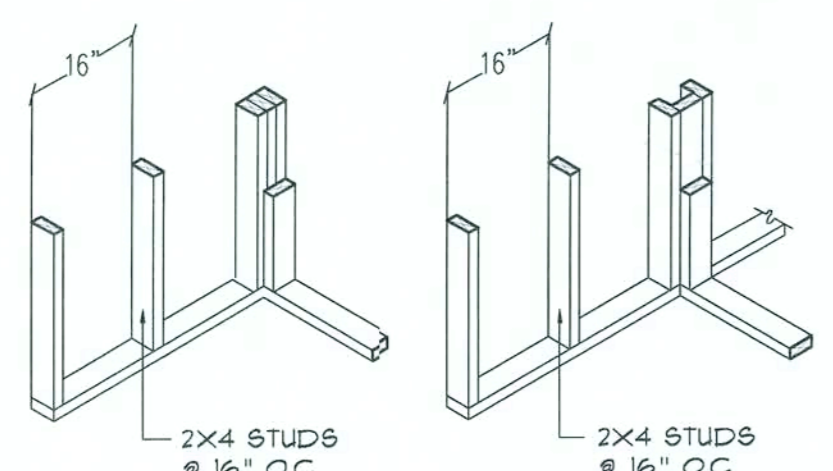

WALL CORNER WALL INTERSECTION

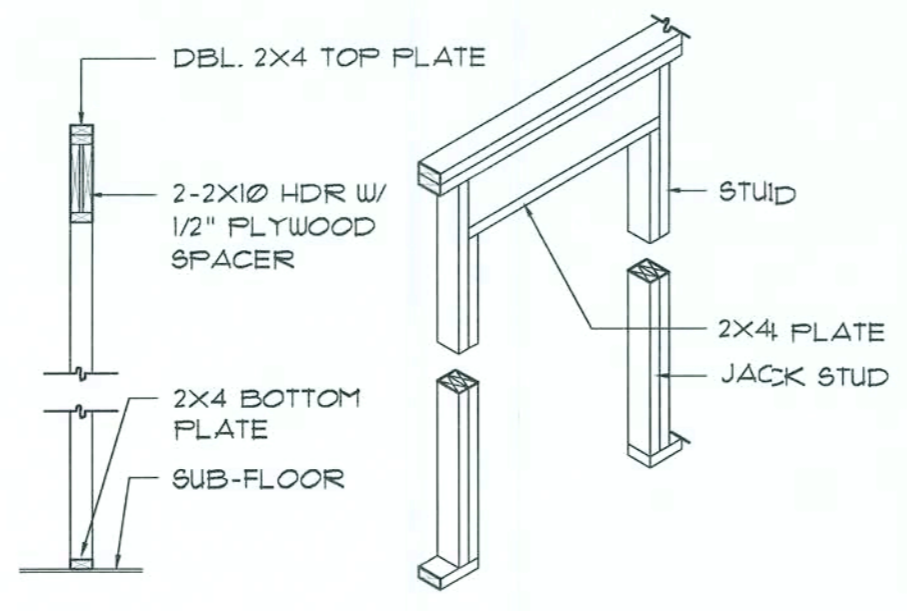

BEARING WALL HEADER

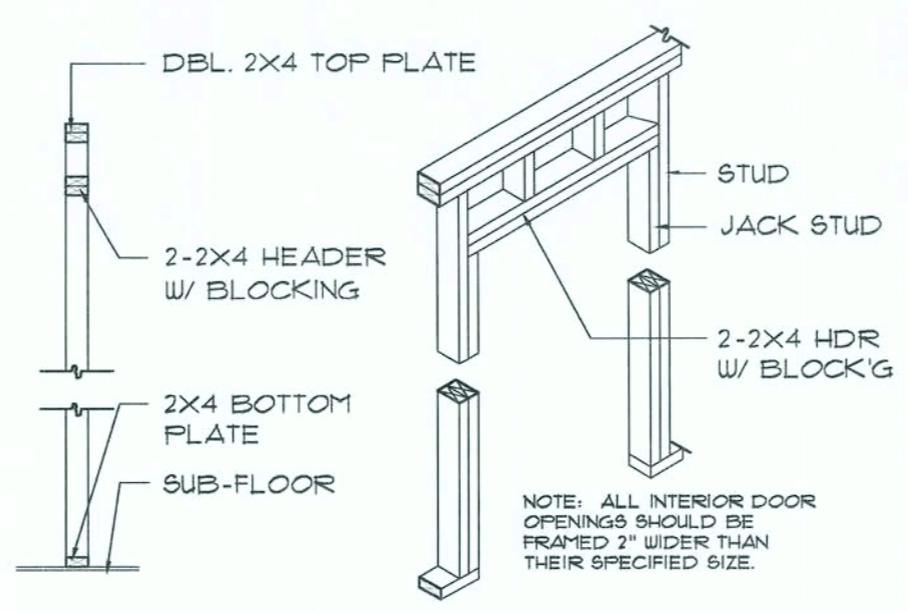

NON-BEARING WALL HEADER

**Framing DETAILS**

SCALE: NONE

**APPLIANCE SPECIFICATIONS**  
 MODEL# KR 43, KC 43, KBY 43, BR# 4315, BCF 4385  
 RD 4300A, HC 4320, HCE 4550A,  
 UVFR 43, UVFC 43, GRDE 8043

**FRAMING SPECIFICATIONS**  
 NOTE: FRAMING DIMENSIONS ARE CALCULATED FOR A  
 NAILING FLANGE DEPTH OF 1/2"

**FRONT VIEW**

**LEFT SIDE** **RIGHT SIDE**

**TOP VIEW**

**FRAMING CORNER**

FRAMING DIMENSIONS	APPLIANCE SIZES
A	38/40 43/45
B	40-3/4" 45-1/2"
C	39" 39"
D	33-3/4" 33-3/4"
E	16-1/8" 16-1/8"
F	11-1/2" 11-1/2"
G	31-3/4" 31-3/4"
H	21-3/8" 21-3/8"
I	4" 4"
J	53-3/8" 53-3/8"

**SUPERIOR.**

**Interior Finish Schedule**

FLOOR AREA:	CARPET AND PAD, PATTERN & COLOR AS PER OWNER OR LAMINATE STRIP WOOD - SEE OWNER FOR SPECS.
BATH FLOOR AREA:	THINSET CERAMIC TILE OR NATURAL STONE FLOOR. COLOR AS SELECTED BY OWNER
BASE:	STYLE & COLOR AS SELECTED BY OWNER OR CERAMIC TILE OR STONE TO MATCH WITH FLOORING
TRIM:	COVES, CROWNS, CASINGS, CHAIRRAIL - STAIN & VARNISH OR PAINT COLOR AS SELECTED BY OWNER
WALLS:	1/2" GWB, PRIMED AND PAINTED 2 COATS LATEX WALL PAINT, COLOR AND GLOSS AS SELECTED BY OWNER
MAIN CEILING:	5/8" GWB, DIRECT HUNG, TAPED & FINISHED, WITH 2 COATS OF LATEX CEILING PAINT COLOR & GLOSS AS SELECTED BY OWNER
APPLIED FINISHES:	APPLIED FINISH TO GWB, (ie: SPRAY, KNOCK-DOWN, SKIP-TROUJEL AND SIMILAR TREATMENTS AS DIRECTED BY OWNER
CABINETS:	AS SELECTED BY THE OWNER, MINIMUM AFI GRADE: "CUSTOM" - ALL COUNTERTOPS SHALL BE SELECTED BY THE OWNER

**Design Data**

2170 SF. - LIVING AREA
558 SF. - REAR PORCH
219 SF. - FRONT PORCH
<b>2947 SF. - TOTAL AREA</b>

**Doors / Windows**

**DOOR DESIGNATIONS**

2068	= 24"X80" DOOR
2468	= 28"X80" DOOR
2668	= 30"X80" DOOR
2868	= 32"X80" DOOR
3068	= 36"X80" DOOR

**WINDOW DESIGNATIONS**

2630	= 30"X36" WINDOW
3020	= 36"X24" WINDOW
3046	= 36"X54" WINDOW
3050	= 36"X60" WINDOW
3060	= 36"X12" WINDOW
4040	= 48"X48" WINDOW
4060	= 48"X12" WINDOW

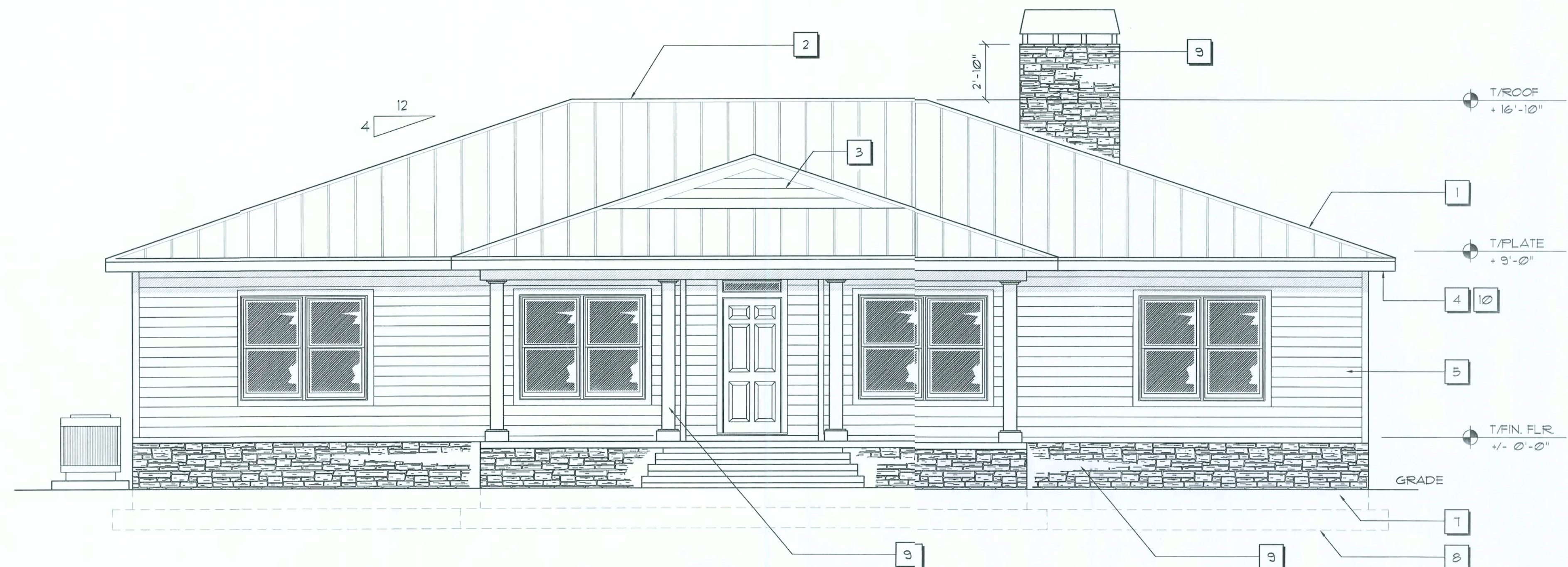

**Front ELEVATION**  
SCALE 1/4" = 1'-0"

**EXTERIOR FINISH LIST**

- 1 24 GA. METAL ROOF SYSTEM
- 2 CONTINUOUS RIDGE VENT
- 3 LOUVERED GABLE VENT
- 4 FASCIA & VENTED SOFFIT
- 5 6" HARD-PLANK SIDING
- 6 BOXED 3 1/2 X 3 1/2 X 1/4" STRUCTURAL TUBING
- 7 8" CONCRETE BLOCK STEMWALL
- 8 12"X24" CONT. CONCRETE FOOTING
- 9 CULTURED STONE VENEER
- 10 24" TYPICAL OVERHANG

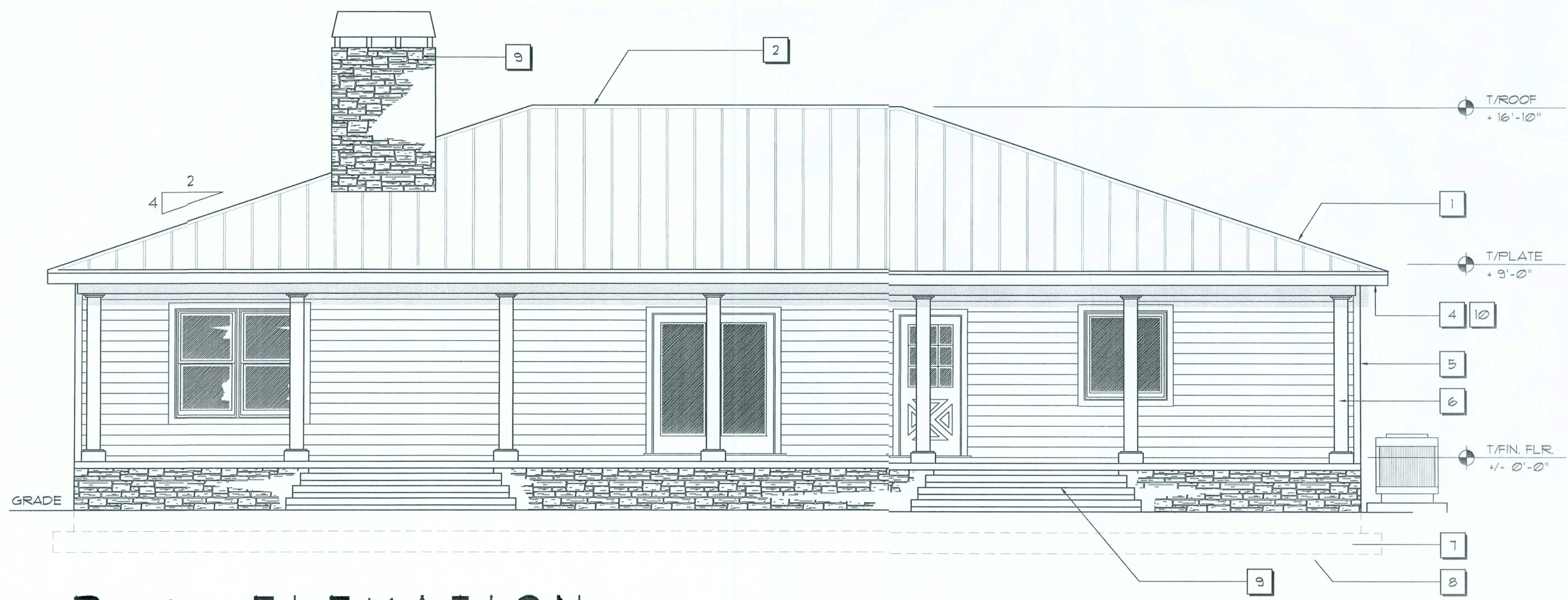

**Rear ELEVATION**  
SCALE 1/4" = 1'-0"

Custom Designed Home for:  
**DANIEL & MICHELLE STAGG**  
COLUMBIA COUNTY, FLORIDA  
**EXTERIOR ELEVATIONS**

**APP**  
ARCHITECTURAL DRAFTING & DESIGN, INC.  
Lake City, FL 32055 • 386.752.4670

**NG**  
NICHOLAS PAUL GEISLER ARCHITECT  
1758 NW Brown Rd.  
Lake City, FL 32055  
386-752-6021

DATE:  
20NOV2007  
COMM:

SHEET:  
A.3  
3 OF 15

*APP*  
13 Nov 2007  
AR0007005

These drawings, as instruments of service, are the sole property of the architect, and may not be used, copied or reproduced in whole or in part for use on or incorporated within any other job without specific and individual authorization by the architect.

These drawings, as instruments of service, are the sole property of the architect, and may not be used, copied or reproduced in whole or in part for use or incorporation within any other job without specific and individual authorization by the architect.

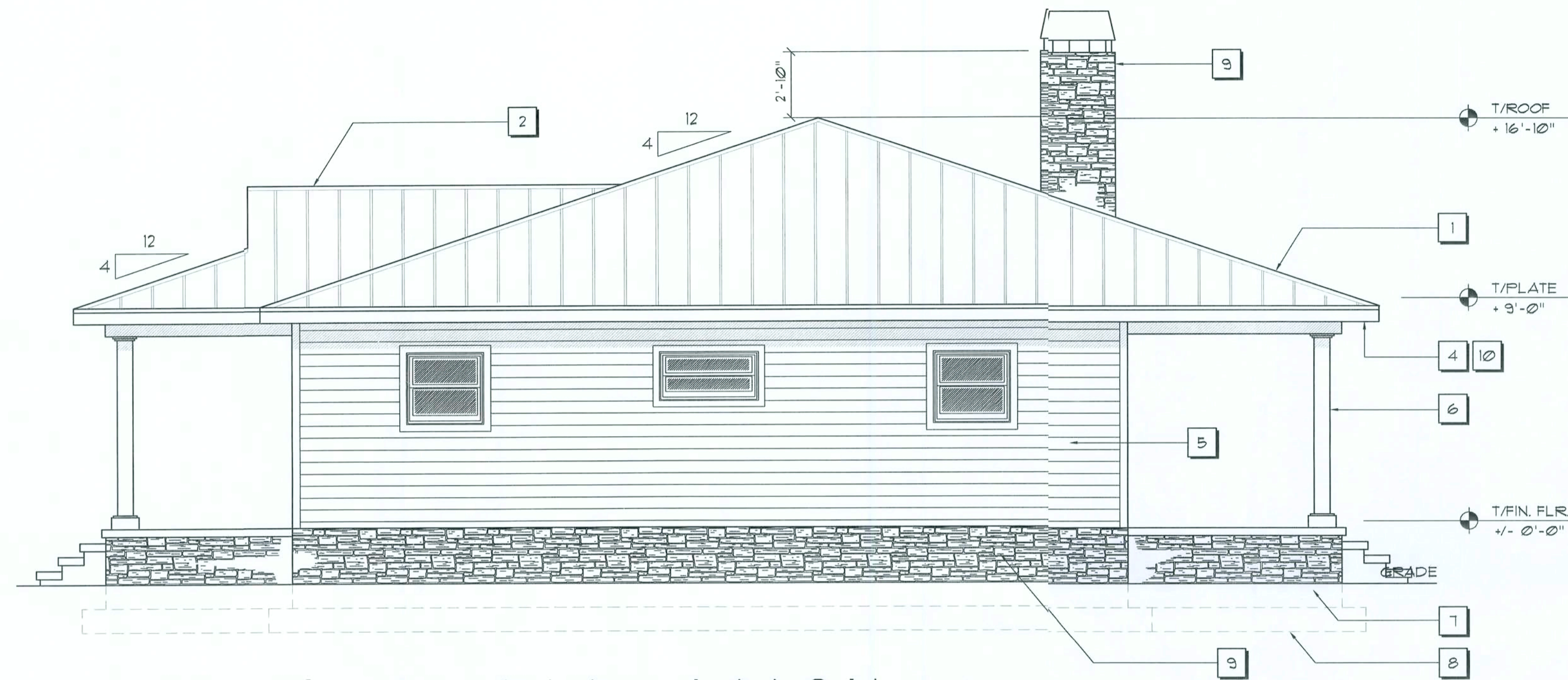

**Left Side ELEVATION**

SCALE 1/4" = 1'-0"

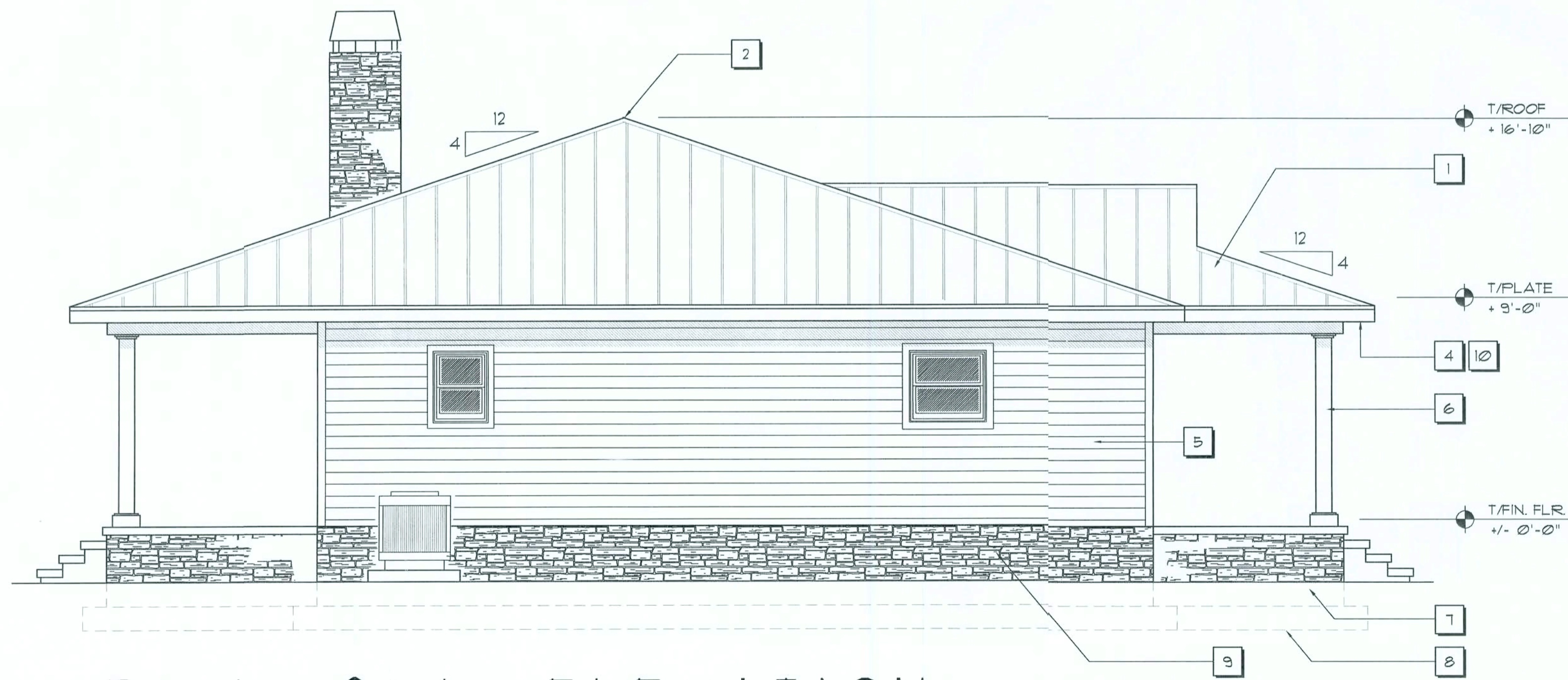

**Right Side ELEVATION**

SCALE 1/4" = 1'-0"

**EXTERIOR FINISH LIST**

- 1 24 GA. METAL ROOF SYSTEM
- 2 CONTINUOUS RIDGE VENT
- 3 LOUVERED GABLE VENT
- 4 FASCIA & VENTED SOFFIT
- 5 6" HARD-PLANK SIDING
- 6 BOXED 3 1/2 X 3 1/2 X 1/4" STRUCTURAL TUBING
- 7 8" CONCRETE BLOCK STEMWALL
- 8 12"X24" CONT. CONCRETE FOOTING
- 9 CULTURED STONE VENEER
- 10 24" TYPICAL OVERHANG

REVISION:

Copyright 2005  
N.P. Geisler, Architect

DRAWN:

DJR

Custom Designed Home for:  
**DANIEL & MICHELLE STAGG**  
 COLUMBIA COUNTY, FLORIDA  
**EXTERIOR ELEVATIONS**

**APP**  
 ARCHITECTURAL DRAFTING & DESIGN, INC.  
 Lake City, FL 32055 • 386.752.4670

**NG**  
 NICHOLAS  
 PAUL  
 GEISLER  
 ARCHITECT  
 N.C.A.R.T.B. Certified  
 1758 NW Brown Rd  
 Lake City, FL 32055  
 386-752-8021

DATE:

20NOV2007

COMM:

SHEET:

A.4

4 OF 15

03 Dec 07  
 AR0007005

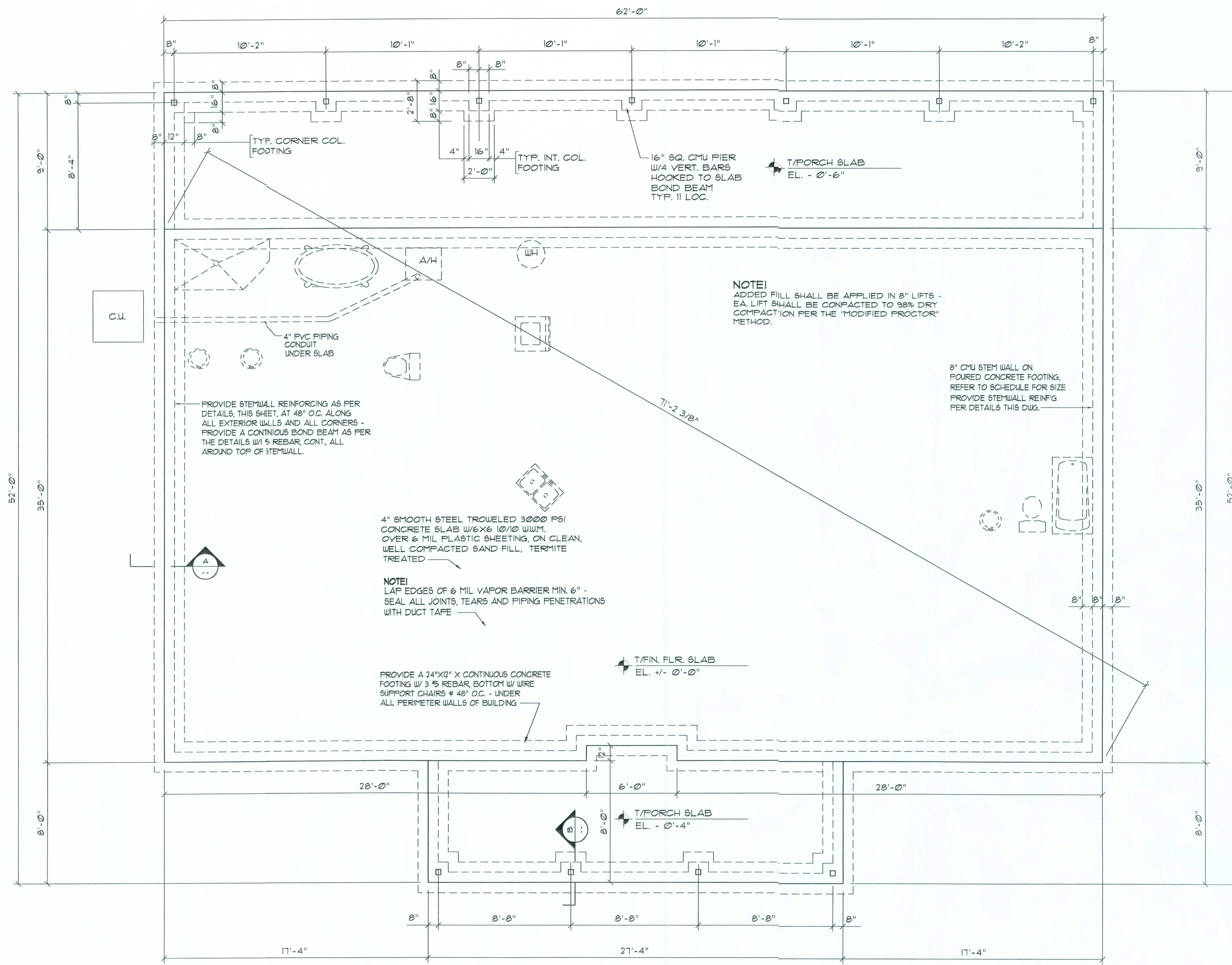

**Foundation PLAN**

SCALE: 1/4" = 1'-0"

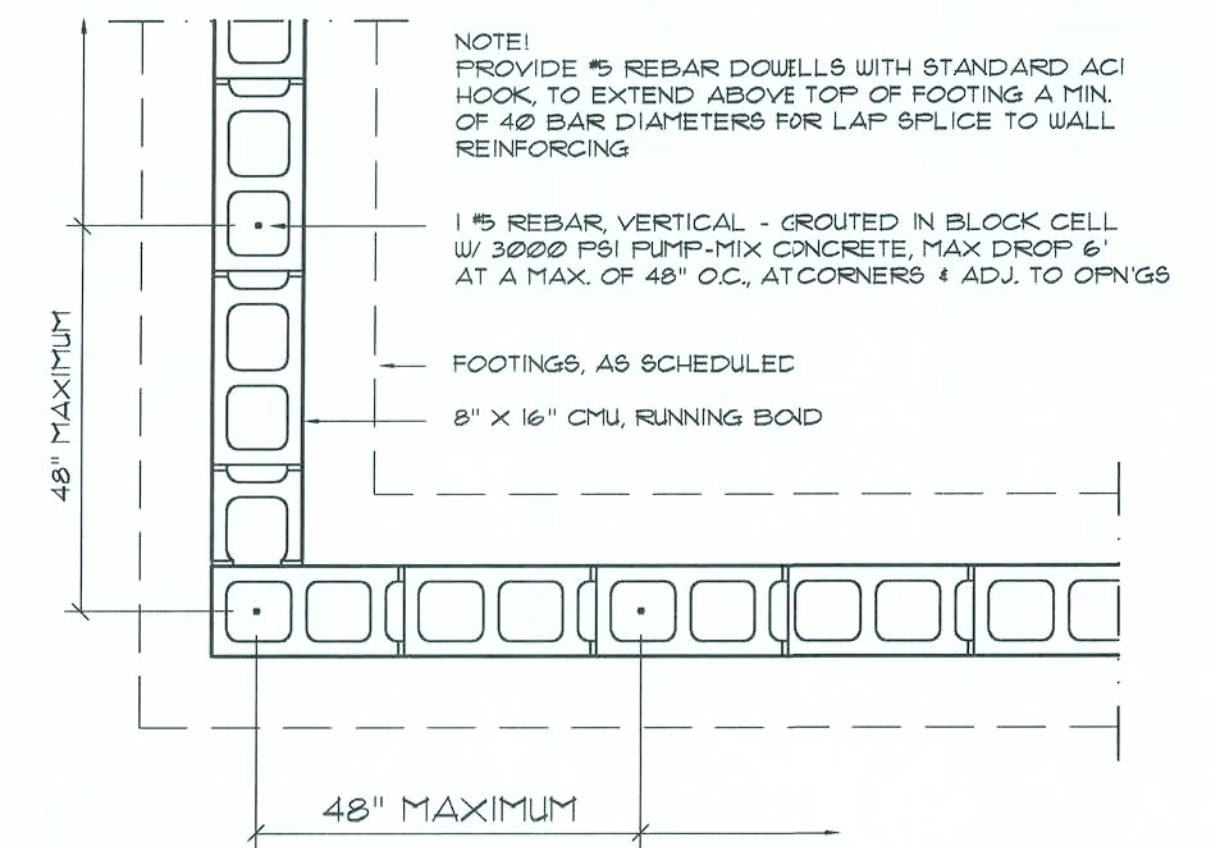

**Wall/Foundation Reinf'g DETAIL**

SCALE: 3/4" = 1'-0"

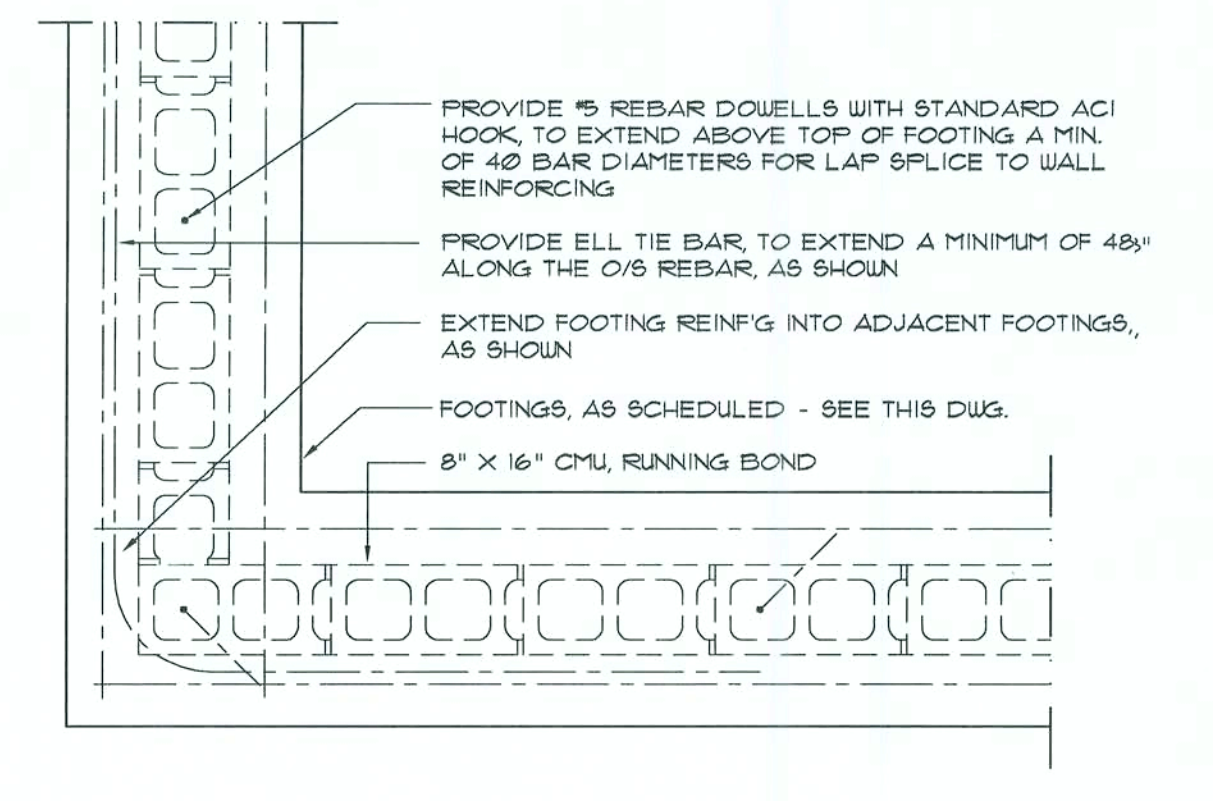

**CONCRETE / MASONRY / METALS GENERAL NOTES:**

- DESIGN SOIL BEARING PRESSURE: 1000 PSF.
- EXPANSIVE SOILS: WHERE DIRECTED BY THE SOILS ENGINEER, SOIL AUGMENTATION PER THE SOILS ENGINEER'S SPECIFICATIONS SHALL BE IMPLEMENTED PRIOR TO PLACING ANY FOUNDATIONS - TESTS AS SPECIFIED SHALL BE PERFORMED TO DETERMINE THE SUITABILITY OF THE SUB-GRADE TO SUPPORT THE DESIGN LOADS.
- CLEAN SAND FILL OVER STRIPPED AND COMPACTED EXISTING GD. SHALL BE PLACED IN 12" LIFTS. BOTH SUB-SOIL AND FILL COMPACTION SHALL BE NOT LESS THAN 98% AS MEASURED BY A MODIFIED PROCTOR TEST AT THE RATE OF ONE TEST FOR EACH 1500 SF OF BUILDING PAD AREA, OR FRACTION THEREOF, FOR EACH 12" LIFT.
- REINFORCING STEEL SHALL BE GRADE 60 AND MEET THE REQUIREMENTS OF ASTM A615, ALL BENDS SHALL BE MADE COLD.
- WELDED WIRE MESH SLAB REINFORCING SHALL MEET THE REQUIREMENTS OF ASTM A185 - MIN. YIELD STRESS = 85 KSI.
- CONCRETE SHALL BE STANDARD MIX F'c = 3000 PSI FOR ALL FTGS, SLABS, COLUMNS AND BEAMS OR SHALL BE STANDARD PUMP MIX F'c = 3000 PSI. STRENGTH SHALL BE ATTAINED WITHIN 28 DAYS OF PLACEMENT, MIXING, PLACING AND FINISHING SHALL BE AS PER ACI STANDARDS.
- CONCRETE BLOCK SHALL BE AS PER MANUFACTURER'S PRODUCT GUIDE FOR ASTM C-90 REQUIREMENTS WITH MEDIUM SURFACE FINISH - F'm = 1500 PSI.
- MORTAR SHALL BE TYPE "M" OR "N" FOR ALL MASONRY UNITS.
- STRUCTURAL STEEL SHALL CONFORM TO ASTM A36 STANDARDS FOR STRENGTH, BOLTS SHALL BE ASTM A307 / GRADE 1 OR A325, AS PER PLAN REQUIREMENTS.
- WELDS SHALL BE AS PER "AMERICAN WELDING SOCIETY" STANDARDS FOR STRUCTURAL STEEL APPLICATIONS.

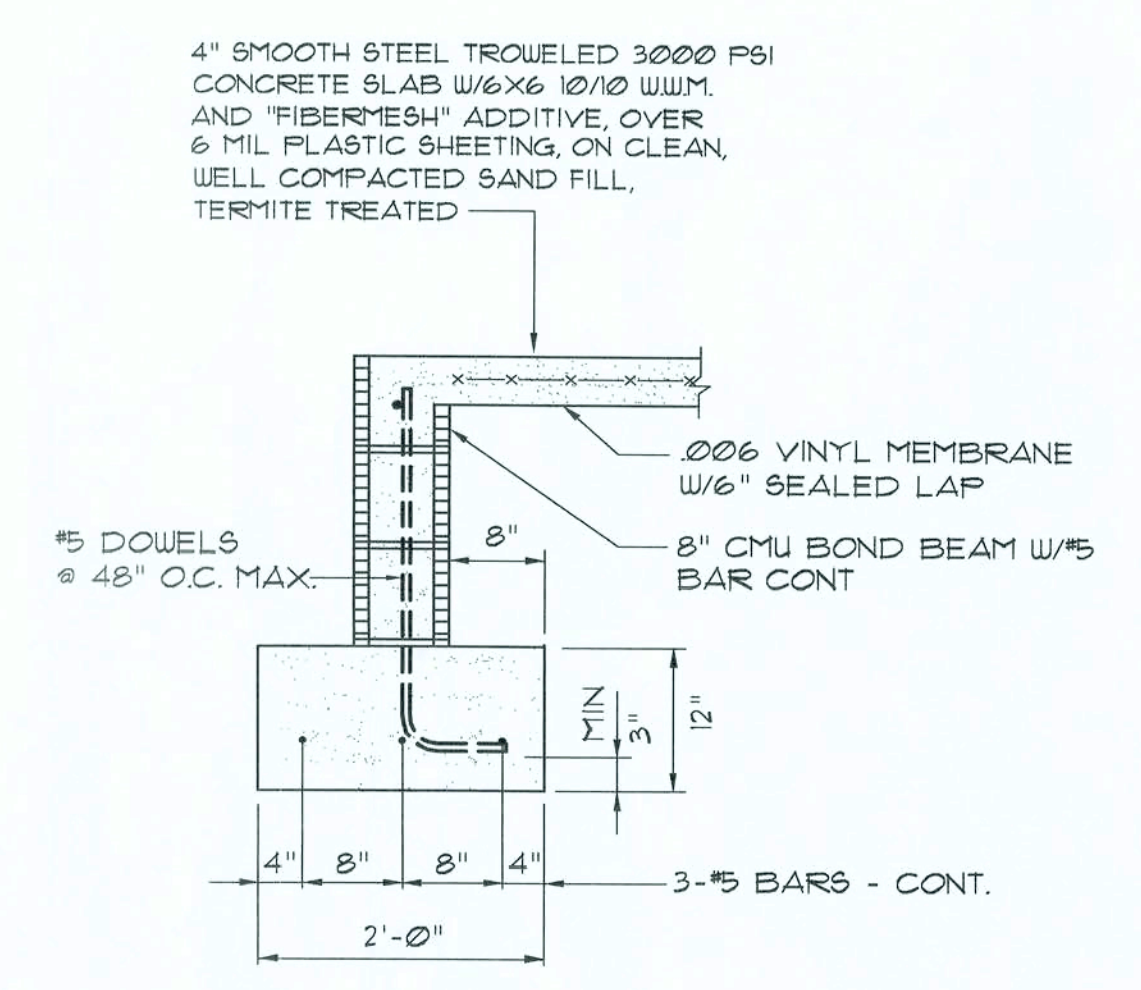

**Typ. Stemwall Ftg.**

SCALE: 3/4" = 1'-0"

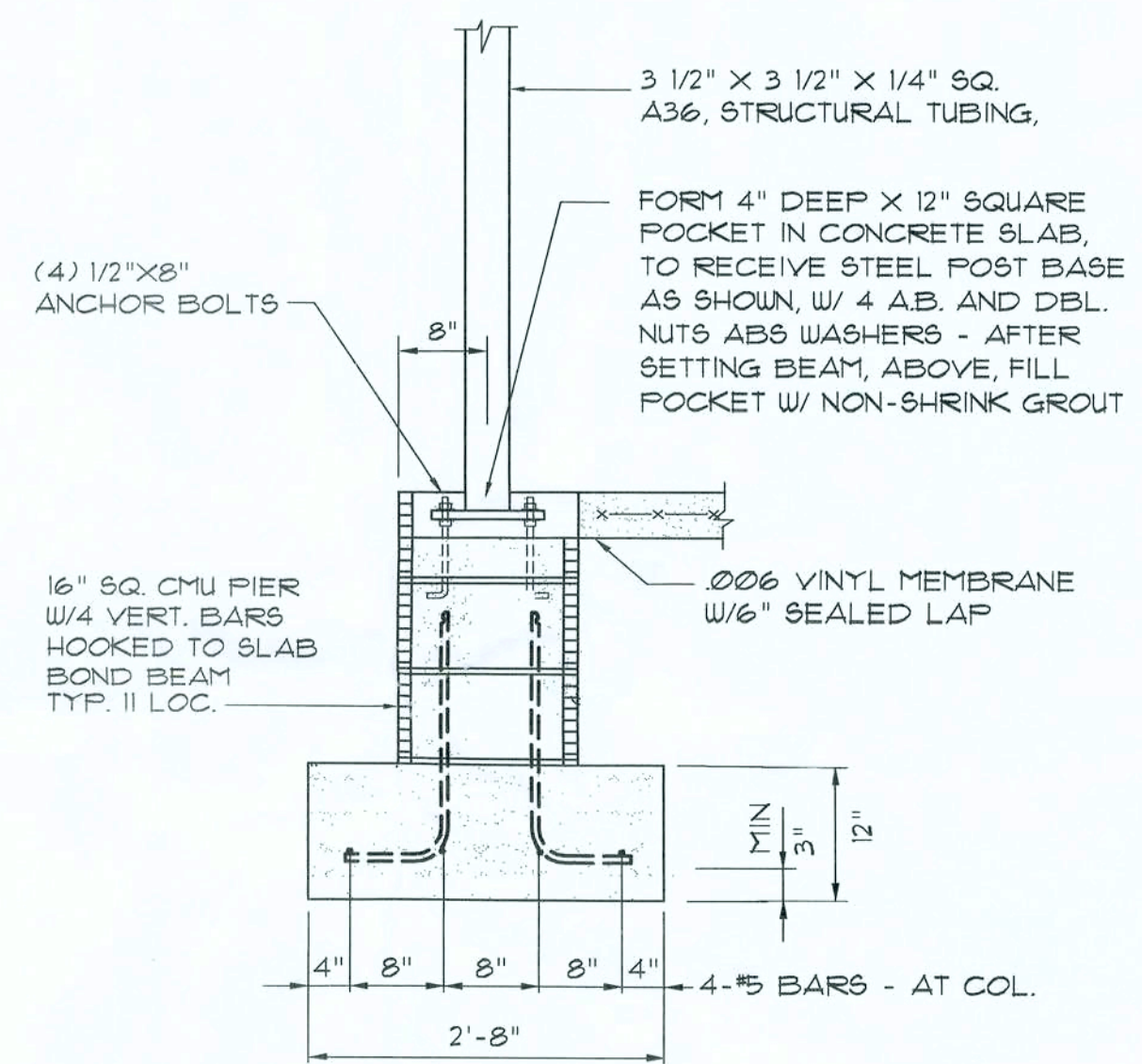

**Typ. Pier SECTION**

SCALE: 3/4" = 1'-0"

**NOTE!**  
PRIOR TO THE CONSTRUCTION OF THE FOUNDATION, THE CONTRACTOR SHALL COORDINATE ANY INTERIOR BEARING LOCATION CONDITIONS PER THE TRUSS ENGINEERED SHOP DRAWINGS WITH THE FOUNDATION PLAN. ANY INTERIOR BEARING LOCATIONS OR ANY POINT LOADS OF 40 K OR GREATER SHALL BE SUPPORTED VIA A MODIFIED FOUNDATION PLAN. TAKING THESE LOADS INTO CONSIDERATION, THE CONTRACTOR SHALL MAKE THE ENGINEERED TRUSS SHOP DRAWINGS AVAILABLE TO THE ARCHITECT FOR THE PURPOSE OF RENDERING SUCH MODIFICATIONS PRIOR TO POURING ANY CONCRETE.

REVISION:

Copyright 2005  
N.P. Geiser, Architect

DRAWN:

DJR

Custom Designed Home for:  
**DANIEL & MICHELLE STAGG**  
COLUMBIA COUNTY, FLORIDA  
**FOUNDATION PLAN**

**ADD**  
ARCHITECTURAL DRAFTING & DESIGN, INC.  
Lake City, FL 32055 - 386.752.4870

**NE**  
NICHOLAS  
GEISLER  
ARCHITECT  
N.C.A.R.B. Certified  
1758 NW Brown Rd.  
Lake City, FL 32055  
386-752-6022

DATE:

20NOV2007

COMM:

SHEET:

**A5**  
5 OF 15

*03 Dec 2007*  
AR0007005

These drawings, as instruments of service, are the sole property of the architect, and may not be used, copied or reproduced in whole or in part for use on or incorporated into any other job without specific and exclusive authorization by the architect.

GALV. UPLIFT CONNECTORS SHALL BE PROVIDED AT EACH TRUSS, IN ACCORDANCE WITH THE SBCCI SECTION 1609. (DESIGN: 110 MPH WIND LOAD)

PREFABRICATED WOOD TRUSSES @ 24" O.C. CERTIFIED BY A FLORIDA ENGINEER TO WITHSTAND 110 MPH WINDS.

24 GA. METAL ROOF SYSTEM, INSTALLED PER MANUFACTURER'S SPECS. TO WITHSTAND 110 MPH WINDS.

30# FELT OVER 15/32" CDX PLYWOOD OR 1/16" O.S.B. SHEATHING

TRUSS ANCHOR STRAP PER "SIMPSON" -ETA SERIES - MATCH TRUSS SHOP DRAWING UPLIFT LOADS TO STRAP W/ EQ. OR GREATER LOAD CAPACITY

+9'-0" TO CEILING WALL

CONT. METAL FLASHING

CONT. ALUMINUM FASCIA OVER 1X6 P/T JOOD SUB-FASCIA, ON P/T 2X4 WOOD BLOCKING

PERF'D ALUMINUM SOFFIT, CONT. ALL AROUND

8" X 16" X CONT. CBS BOND BEAM, W/ 2 #1 CONT. (OR 4 #5); PROVIDE 1" #4 ELL BAR 15" X 15", LAPPED TO VERTICAL REBAR AND BOND BEAM REBAR

SEE 'ROOF FRAMING PLAN'

1/2" GUB WALL FINISH ON P/T WOOD FURRING @ 16" O.C., W/ R3 BATT INSULATION - FINISH W/ KNOCK-DOWN APPLIED TEXTURE - PAINT 2 COATS

DUR-O-WALL METAL REINFORCING @ 16" O.C. VERTICAL

#5 DOUELS @ 48" O.C.

6" "HARDI-PLANK" SIDING ON P/T WOOD FURRING @ 16" O.C., COLOR BY OWNER

#5 REBAR DOUELL, MIN. LAP 6PLICE SHALL BE NOT LESS THAN 30 BAR DIAMETERS OR 15"

#5 DOUELS @ 48" O.C. MAX.

3-#5 BARS CONTINUOUS

## Typ Wall SECTION

SCALE: 3/4" = 1'-0"

A  
A3

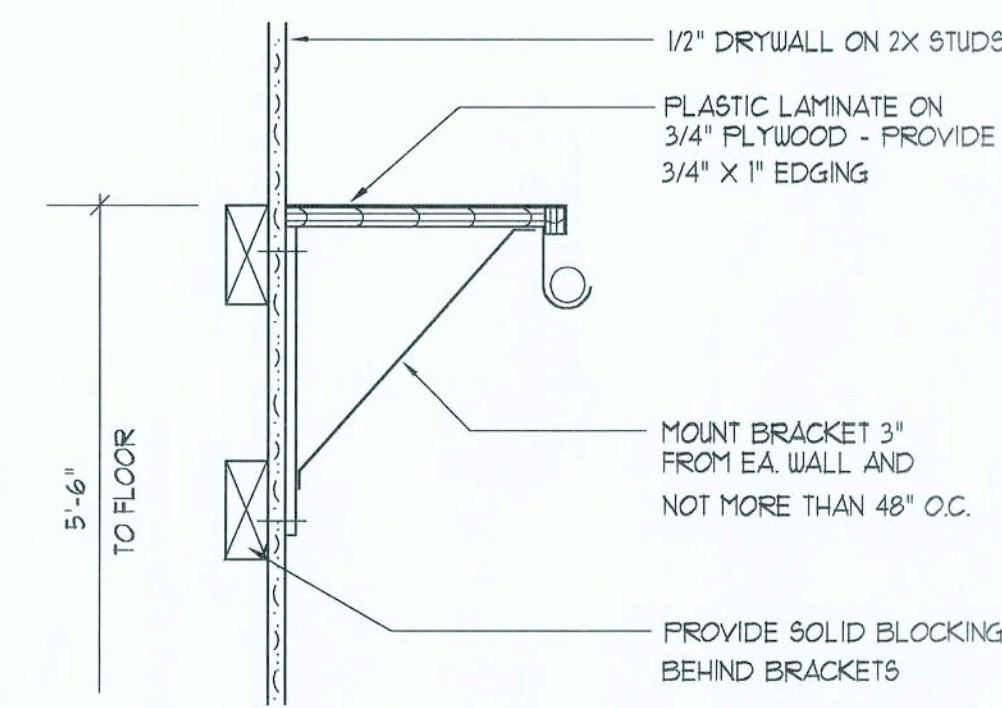

## Closet Rod & Shelf Detail

SCALE: NONE

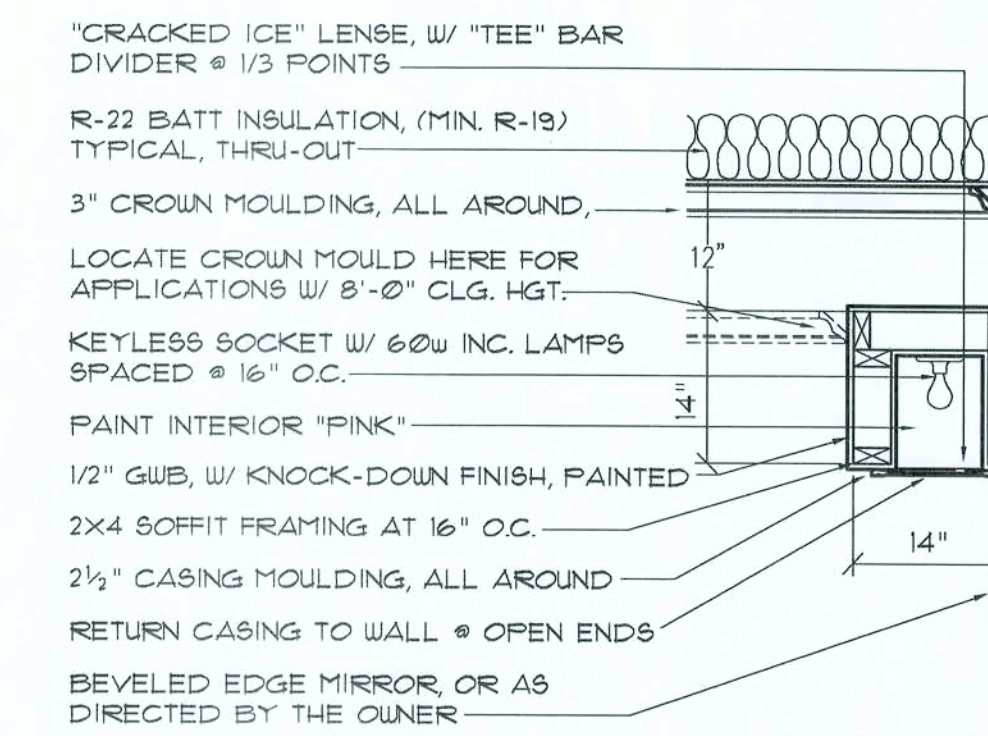

## Optional Lighting DETAIL

SCALE: NONE ( ABOVE BATHROOM VANITY )

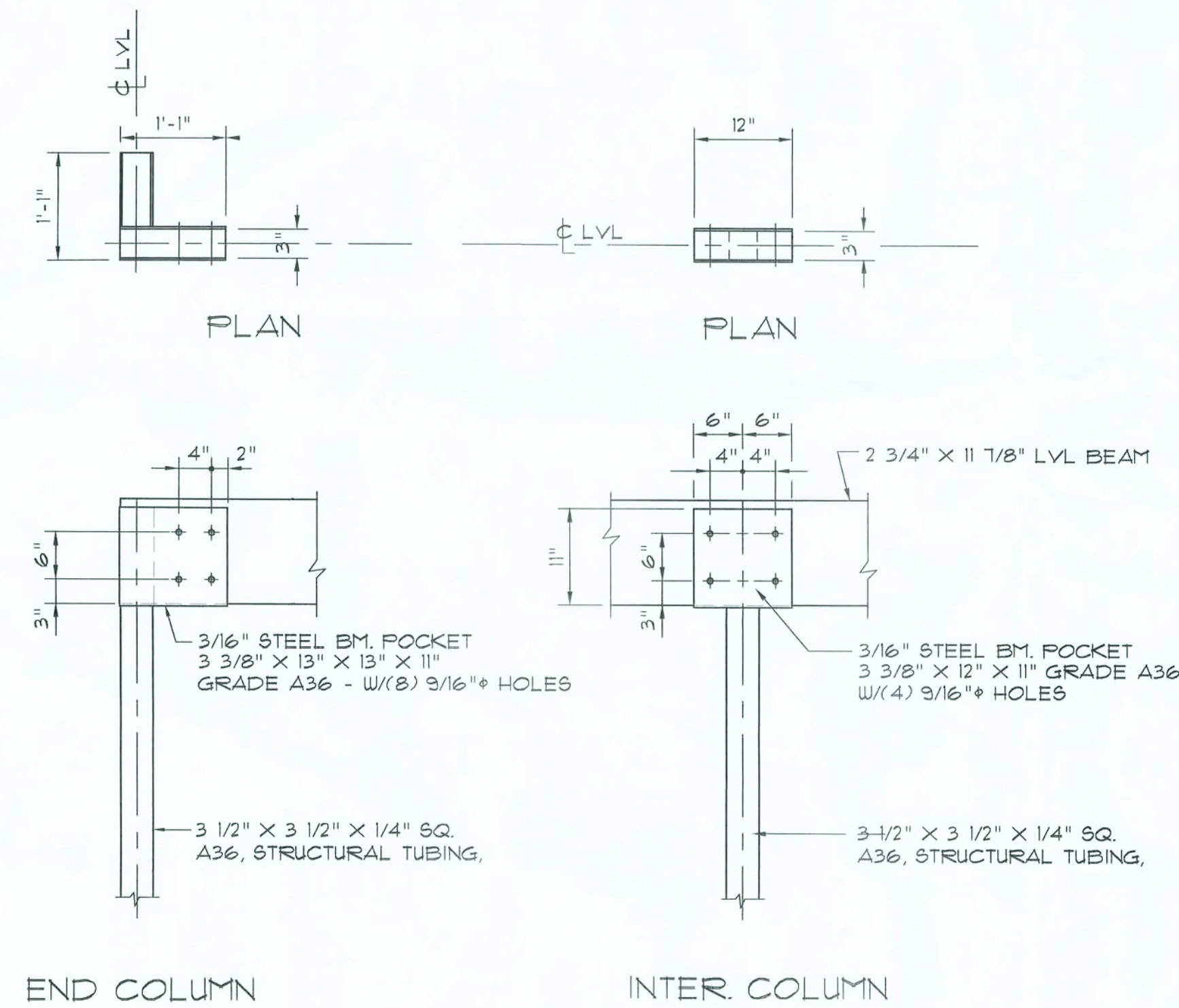

## Porch Steel Post Details

SCALE: N.T.S.

### STEEL POST NOTES:

1. LENGTH OF POSTS SHALL BE DETERMINED WITH FIELD MEASUREMENTS OF AS-BUILT CONDITIONS - POST BEARING 16 2" BELOW FLOOR SLAB ELEVATION
2. ALL POST COMPONENTS SHALL BE FULLY WELDED CHIPED AND SHOP PAINTED.
3. RED IRON WORK SHALL REQUIRE SHOP DRAWINGS FOR APPROVAL PRIOR TO FABRICATION OF THE PRODUCT.
4. NOTE ORIENTATION OF BOTH THE BASE PLATE AND BEAM SUPPORTS !!!

REVISION:

Copyright 2005  
N.P. Geiser, Architect

DRAWN:

DJR

Custom Designed Home for:  
**DANIEL & MICHELLE STAGG**  
COLUMBIA COUNTY, FLORIDA  
TYP. WALL SECTION & DETAILS

**ADD**  
ARCHITECTURAL DRAFTING & DESIGN, INC.  
Lake City, FL 32055 - 386.752.4870

**NS**  
NICHOLAS ADRIAN GEISER ARCHITECT  
N.C.A.R.B. Certified  
1758 NW Brown Rd.  
Lake City, FL 32055  
386-752-4870

DATE:

20NOV2007

COMM:

SHEET:

A6

6 OF 15

*NS*  
03/28/2007  
AR0007005

GALV. UPLIFT CONNECTORS SHALL BE PROVIDED AT EACH TRUSS, IN ACCORDANCE WITH THE SBCCI SECTION 1603. (DESIGN: 110 MPH WIND LOAD)

PREFABRICATED WOOD TRUSSES @ 24" O.C. CERTIFIED BY A FLORIDA ENGINEER TO WITHSTAND 110 MPH WINDS.

24 GA. METAL ROOF SYSTEM, INSTALLED PER MANUFACTURERS SPECS. TO WITHSTAND 110 MPH WINDS.

30" FELT OVER 15/32" CDX PLYWOOD OR 1/16" O.S.B. SHEATHING

TRUSS ANCHOR STRAP PER "SIMPSON" HETA SERIES - MATCH TRUSS SHOP DRAWING UPLIFT LOADS TO STRAP W/ EQ. OR GREATER LOAD CAPACITY

CONT. METAL FLASHING

CONT. ALUMINUM FASCIA OVER 1x6 P/T WOOD SUB-FASCIA, ON P/T 2x4 WOOD BLOCKING

PERF'D ALUMINUM SOFFIT, CONT. ALL AROUND

8" X 16" X CONT. CBS BOND BEAM, W/ 2 #1, CONT. (OR 4 #5), PROVIDE 1 - #4 ELL BAR 15" X 15", LAPPED TO VERTICAL REBAR AND BOND BEAM REBAR

SEE 'ROOF FRAMING PLAN'

1/2" GWB WALL FINISH ON P/T WOOD FURRING @ 16" O.C. W/ R3 BATT INSULATION - FINISH W/ KNOCK-DOWN APPLIED TEXTURE - PAINT 2 COATS

DUR-O-WALL METAL REINFORCING @ 16" O.C. VERTICAL

#5 DOWELS @ 48" O.C.

6" "HARDI-PLANK" SIDING ON P/T WOOD FURRING @ 16" O.C. COLOR BY OWNER

#5 REBAR DOWELL, MIN. LAP SPLICE SHALL BE NOT LESS THAN 30 BAR DIAMETERS OR 15"

#5 DOWELS @ 48" O.C. MAX.

3-#5 BARS CONTINUOUS

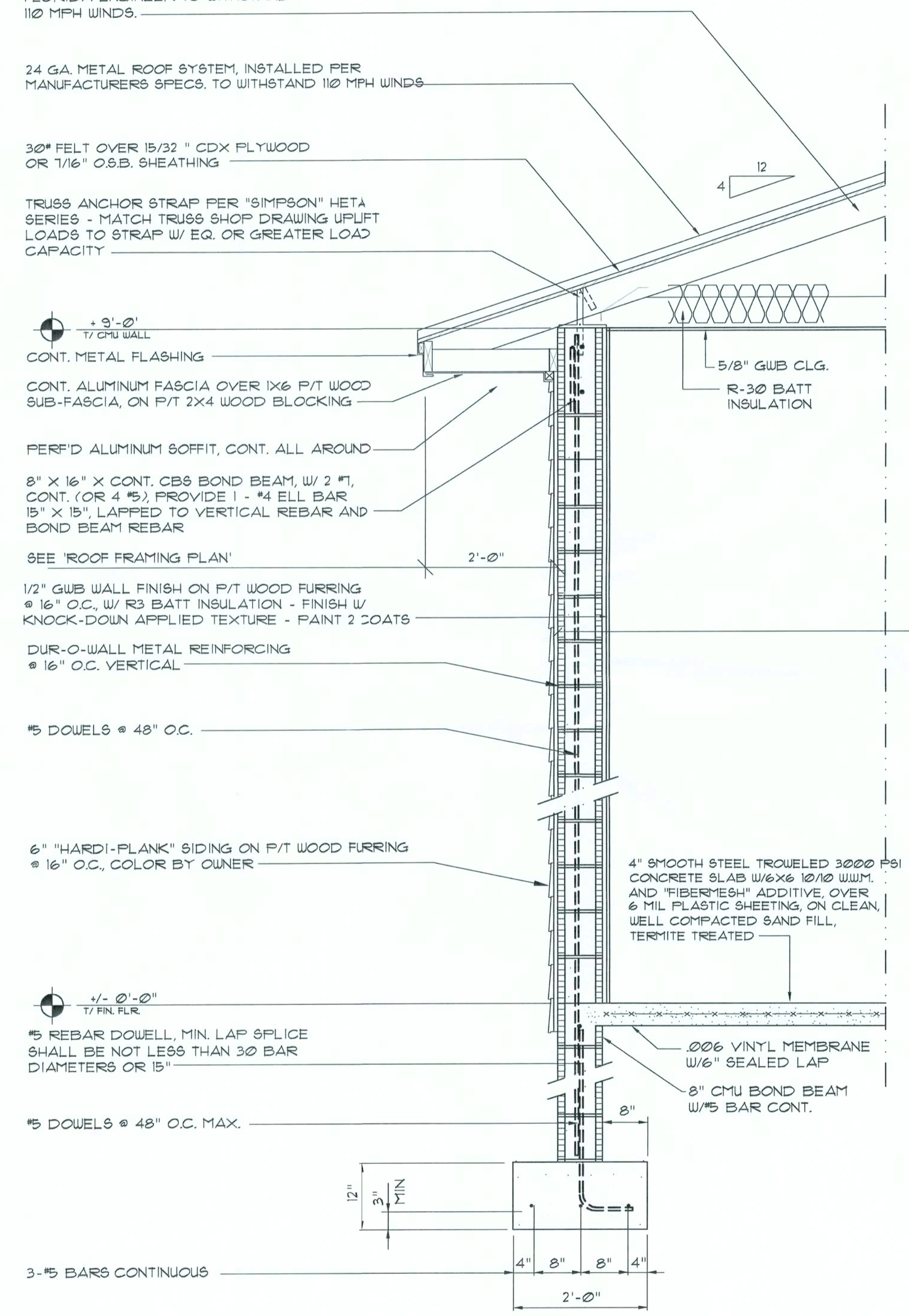

GALV. UPLIFT CONNECTORS SHALL BE PROVIDED AT EACH TRUSS, IN ACCORDANCE WITH THE SBCCI SECTION 1603. (DESIGN: 110 MPH WIND LOAD)

PREFABRICATED WOOD TRUSSES @ 24" O.C. CERTIFIED BY A FLORIDA ENGINEER TO WITHSTAND 110 MPH WINDS.

24 GA. METAL ROOF SYSTEM, INSTALLED PER MANUFACTURERS SPECS. TO WITHSTAND 110 MPH WINDS.

30" FELT OVER 15/32" CDX PLYWOOD OR 1/16" O.S.B. SHEATHING

TRUSS ANCHOR STRAP PER "SIMPSON" HETA SERIES - MATCH TRUSS SHOP DRAWING UPLIFT LOADS TO STRAP W/ EQ. OR GREATER LOAD CAPACITY

5/8" GWB CLG.

R-30 BATT INSULATION

PERF'D ALUMINUM SOFFIT, CONT. ALL AROUND

8" X 16" X CONT. CBS BOND BEAM, W/ 2 #1, CONT. (OR 4 #5), PROVIDE 1 - #4 ELL BAR 15" X 15", LAPPED TO VERTICAL REBAR AND BOND BEAM REBAR

1/2" GWB WALL FINISH ON P/T WOOD FURRING @ 16" O.C. W/ R3 BATT INSULATION - FINISH W/ 4 TEXTURE PER OWNERS SPECS. - PAINT 2 COATS

DUR-O-WALL METAL REINF. @ 16" O.C. VERTICAL

#5 DOWELS @ 48" O.C.

6" "HARDI-PLANK" SIDING ON P/T WOOD FURRING @ 16" O.C. COLOR BY OWNER

4" SMOOTH STEEL TROUELED 3000 PSI CONCRETE SLAB W/6x6 10/10 W/W.M. AND "FIBERMESH" ADDITIVE, OVER 6 MIL PLASTIC SHEETING, ON CLEAN, WELL COMPACTED SAND FILL, TERMITE TREATED

VARIES: 4" AT FRONT PORCH  
6" AT REAR PORCH

4-#5 BARS - AT COL.

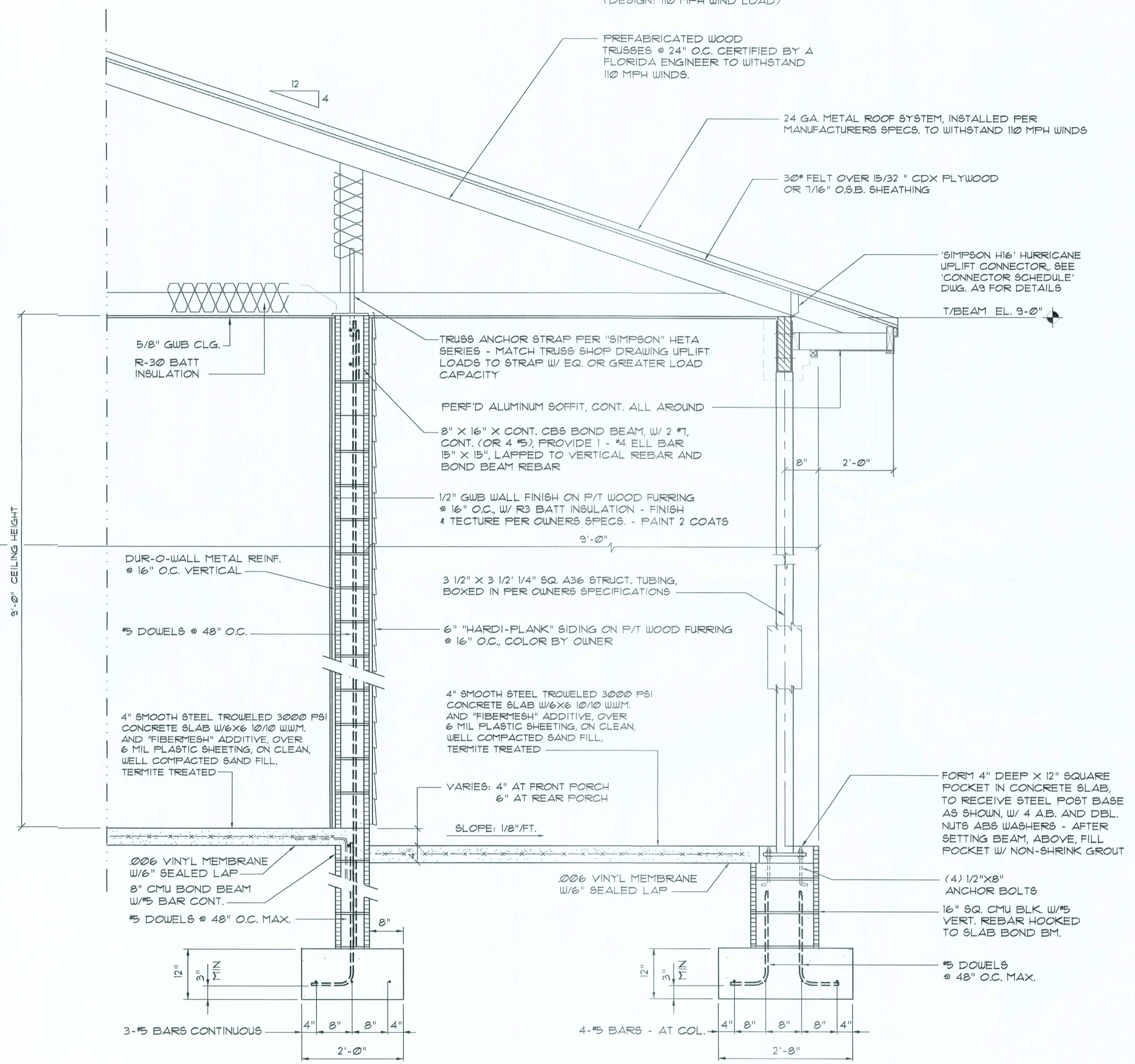

NOTE: ASSUMED SOIL BEARING CAPACITY 1000 PSF

**Typ Building SECTION** **B**  
SCALE: 3/4" = 1'-0" **A3**

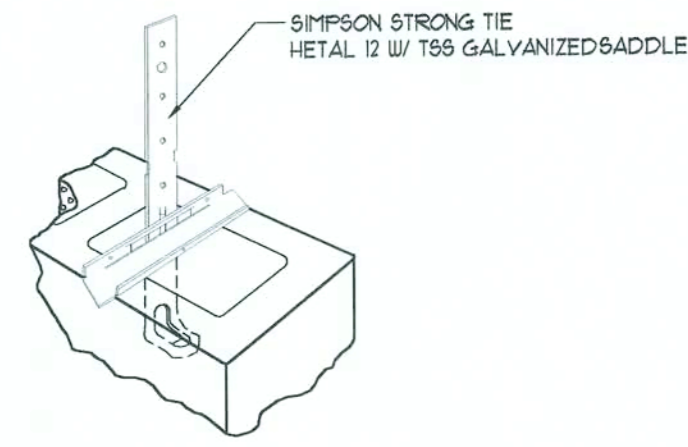

**TRUSS TO TIE BEAM HOLDDOWN CONNECTOR**  
SCALE: NONE

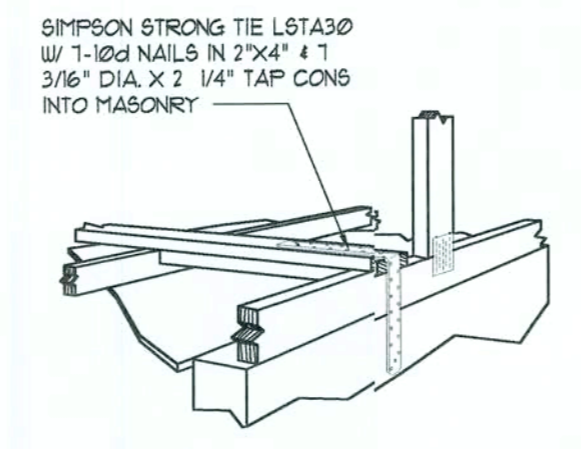

**GABLE END GYPSUM DIAPHRAGM HOLDDOWN CONNECTOR**  
SCALE: NONE

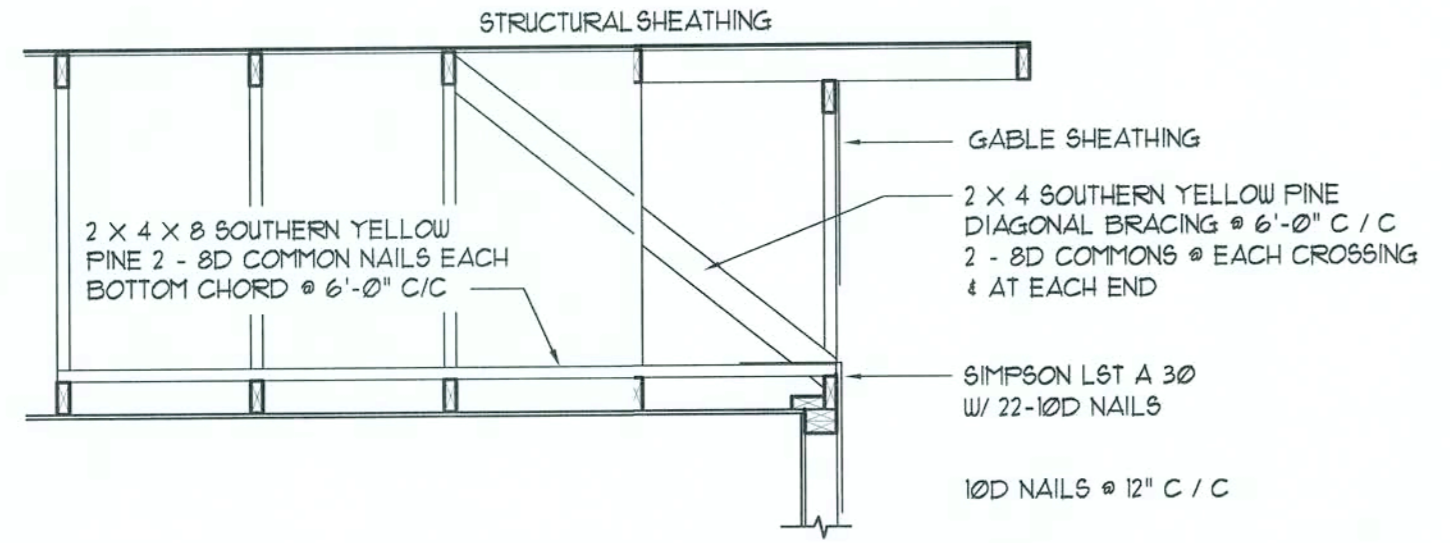

**END WALL BRACING FOR CEILING DIAPHRAGM**  
NTS (ALTERNATIVE TO BALLOON FRAMING)  
NOTE: ALL WOOD TO BE NUMBER 2 GRADE SOUTHERN YELLOW PINE

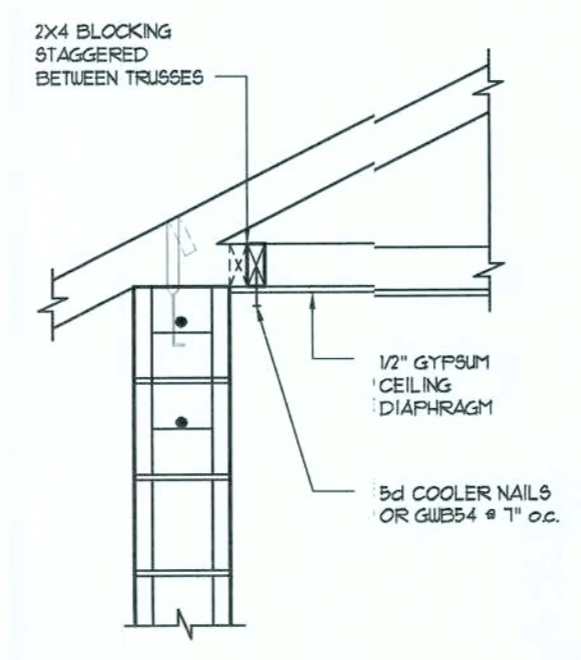

**GYPSUM CEILING DIAPHRAGM TO SIDEWALL CONNECTION**

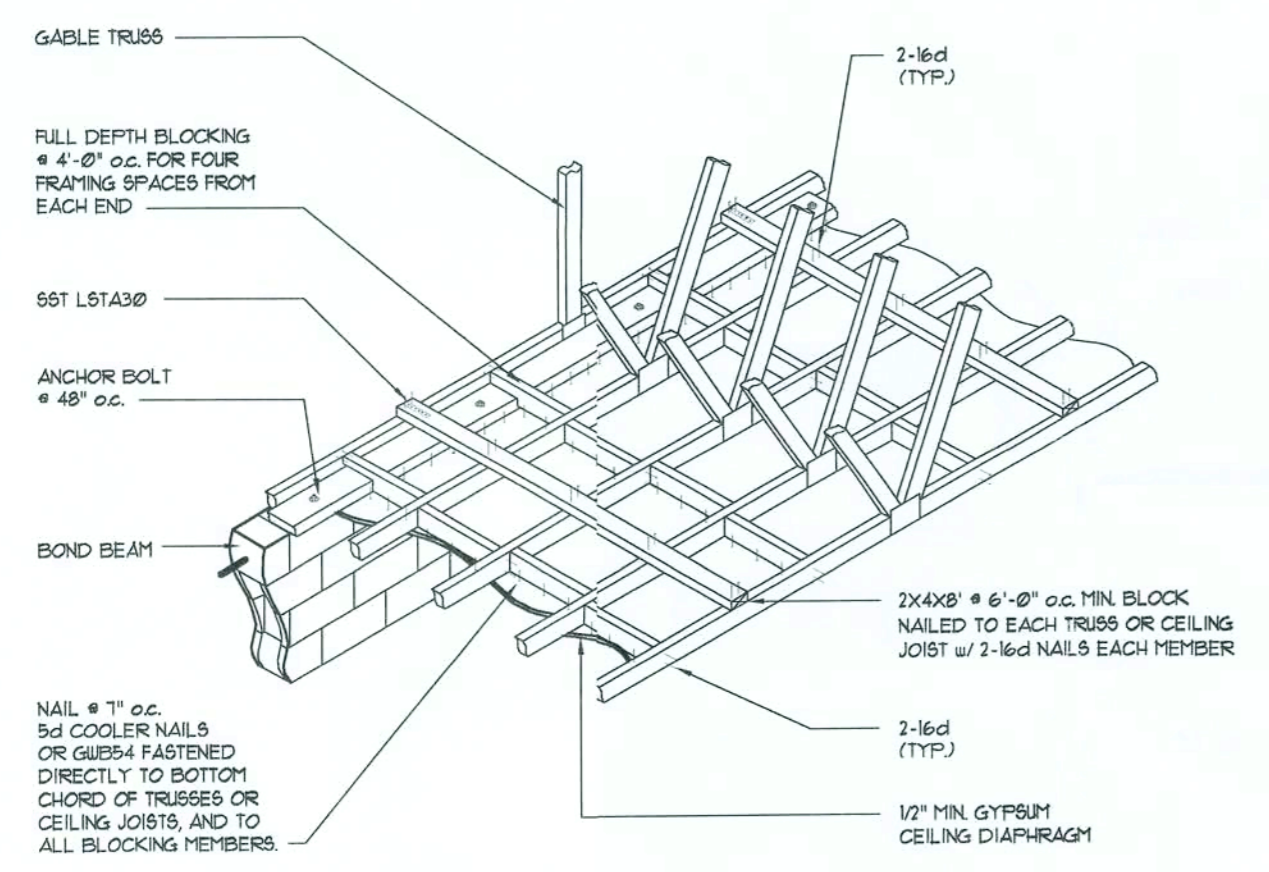

**DIRECT TRUSS TO MASONRY CONNECTION ENDWALL FOR GYPSUM CLG DIAPHRAGM**  
SCALE: NONE

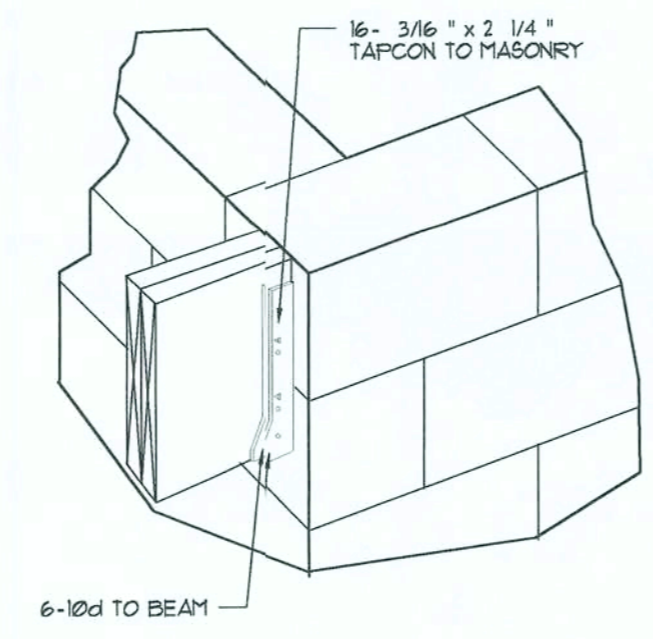

**SIMPSON HUSC410**  
SCALE: NONE WOOD BEAM TO MASONRY

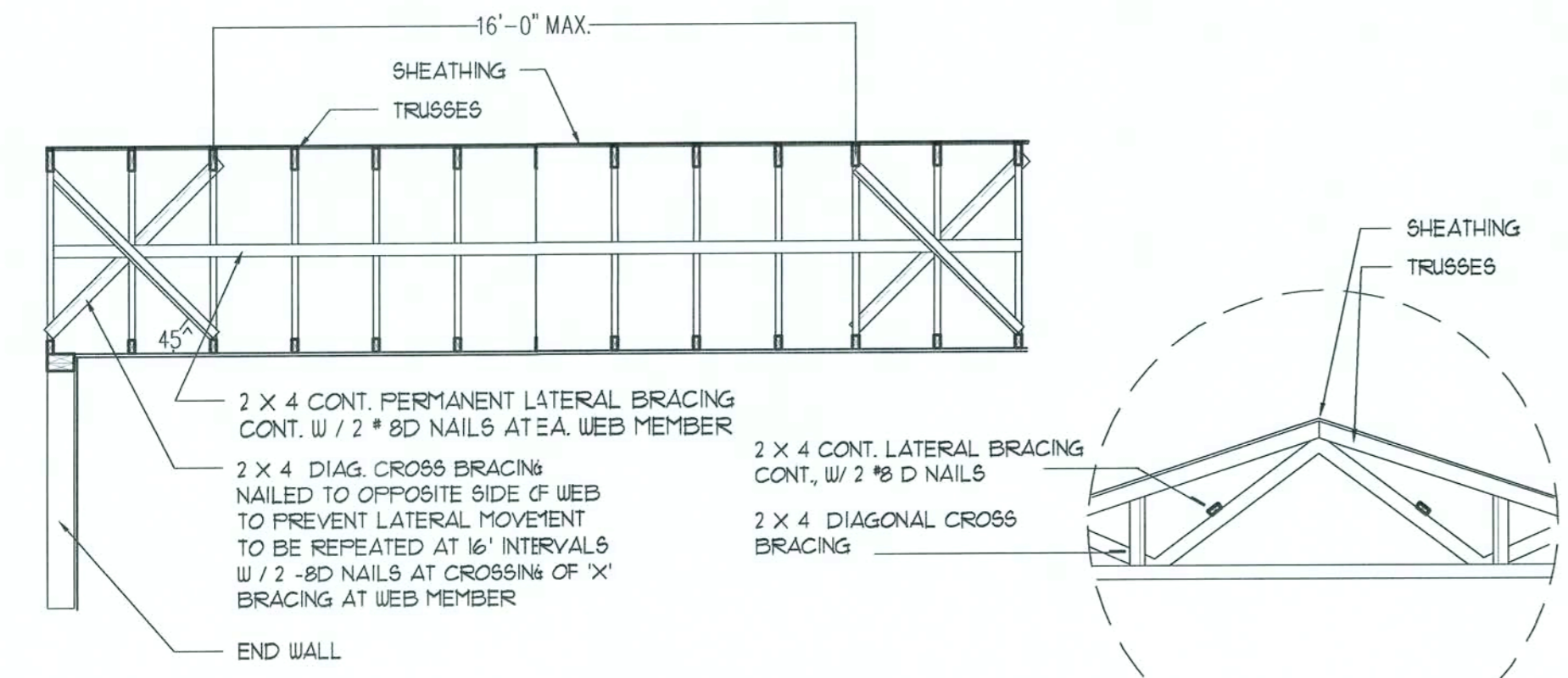

**TYP. PERMANENT TRUSS BRACING DIA.**  
NTS  
NOTE: ALL WOOD TO BE NUMBER 2 GRADE SOUTHERN YELLOW PINE

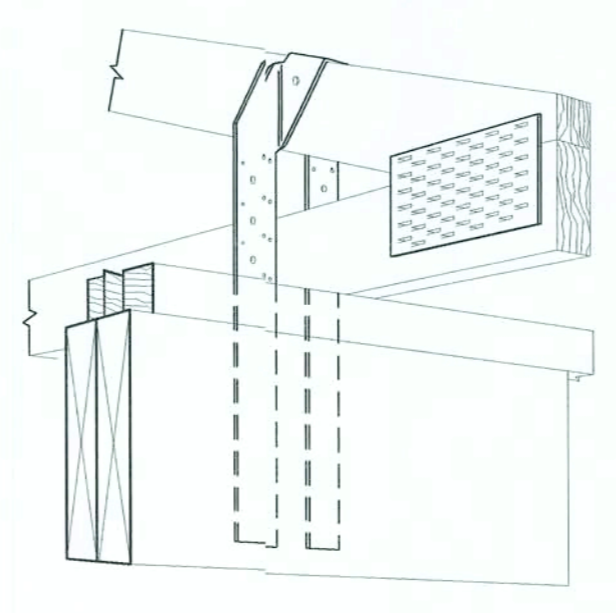

**SIMPSON H16**  
SCALE: NONE TRUSS TO WOOD BEAM

**Truss Bracing DETAILS**  
SCALE: AS NOTED

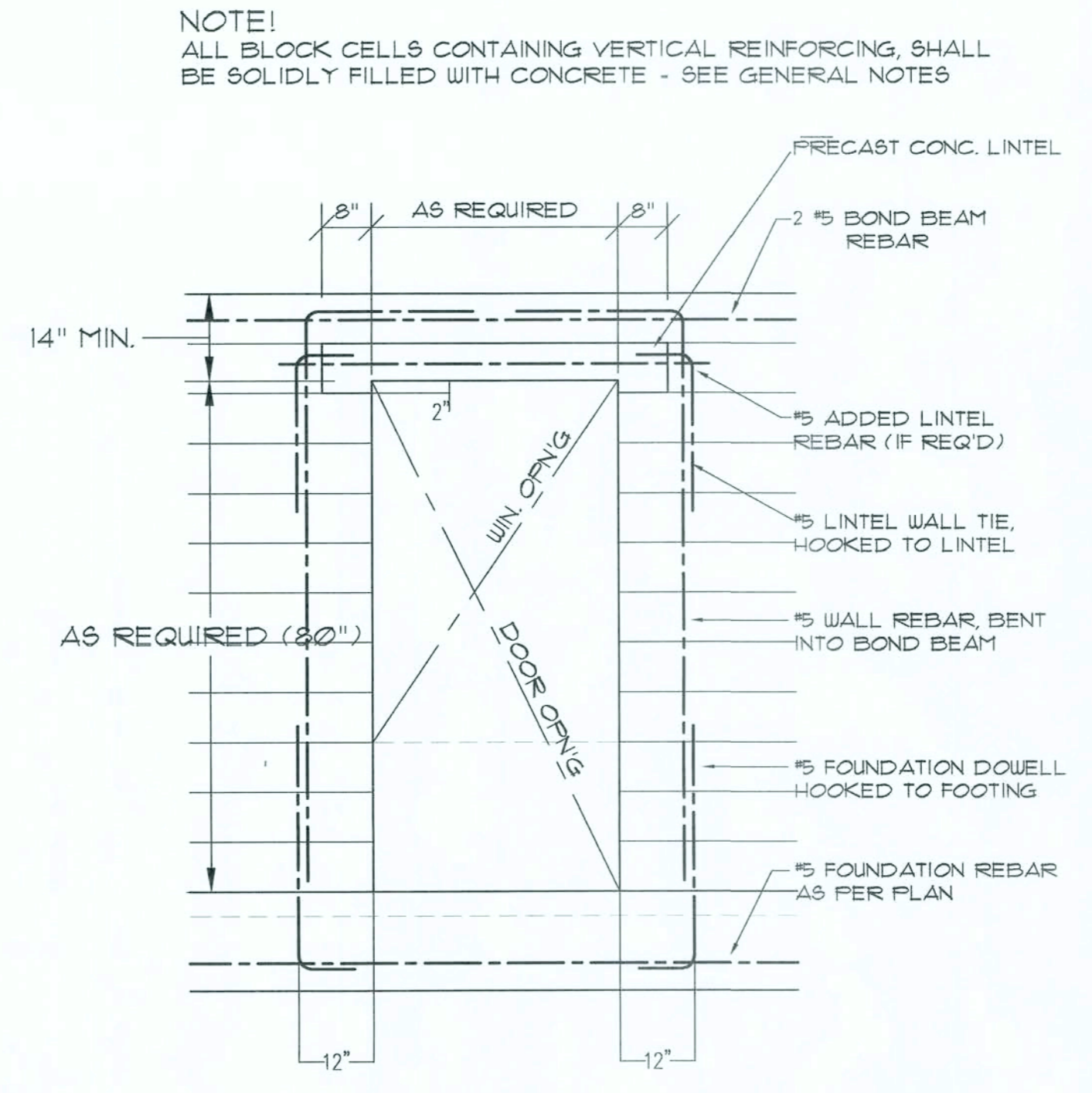

**Typical Door/Window Opening Reinforcing DETAIL**  
SCALE: 1/2" = 1'-0"

NOTE! REFER TO GENERAL NOTES FOR LAP SPLICE AND HOOK MINIMUM LENGTH/SIZE - ALL PER ACI 318-LATEST

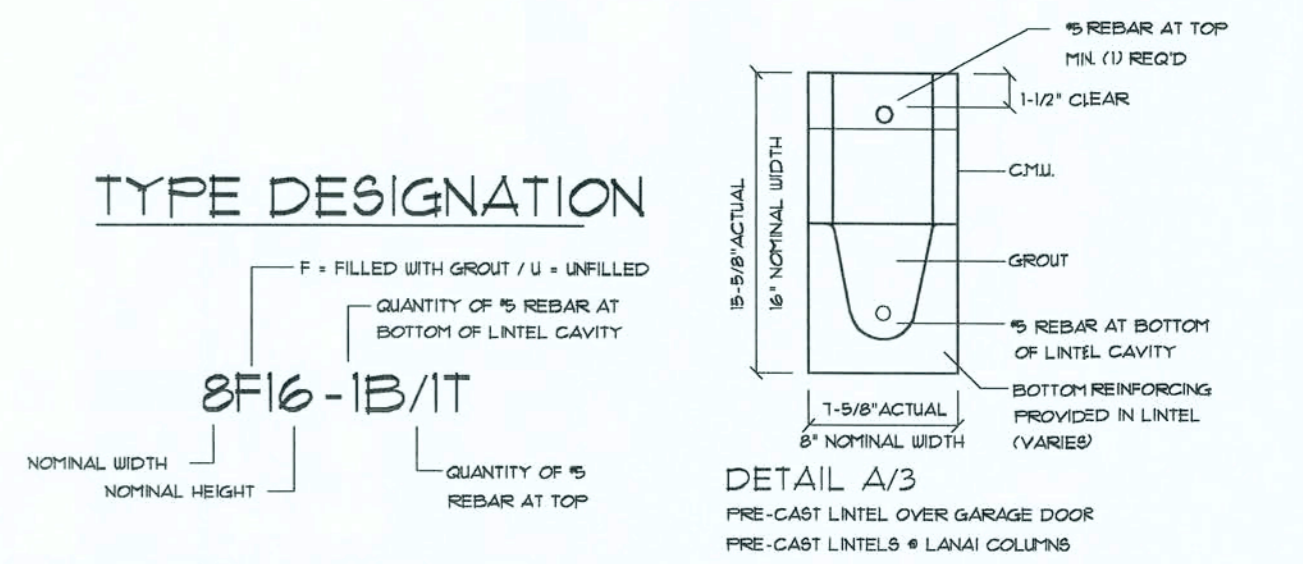

**8" PRECAST # PRESTRESSED U-LINTELS**

MARK	LENGTH	TYPE	8F16-05	GRAVITY														
				8F16-05	8F16-05	8F16-05	8F16-05	8F16-05	8F16-05	8F16-05	8F16-05							
L1	2'-0"	PRECAST	2302	3166	4473	6079	7576	9004	10472	11956								
L2	3'-0"	PRECAST	2302	3166	4473	6079	7576	9004	10472	11956								
L3	4'-0"	PRECAST	2029	2646	4473	6079	7576	9004	10472	11956								
L4	4'-6"	PRECAST	1651	2127	4027	6079	7576	9004	10472	11956								
L5	5'-4"	PRECAST	184	1669	2889	5051	6079	9400	6424	1000								
L6	5'-10"	PRECAST	972	1029	1029	1474	1809	2364	2701	3371								
L7	6'-6"	PRECAST	931	1255	2101	3356	5260	754	8955	6900								
L8	7'-6"	PRECAST	761	1029	1675	2610	3639	5096	6613	8241								
L9	8'-4"	PRECAST	513	768	112	188	2844	3409	4050	4701								
L10	10'-0"	PRECAST	456	487	802	125	195	322	530	835								
L11	11'-4"	PRECAST	445	590	935	1365	1804	2441	3195	4044								
L12	12'-0"	PRECAST	414	555	864	1254	1673	221	2832	3590								
L13	13'-4"	PRECAST	362	421	726	1028	1331	1635	214	282								
L14	14'-0"	PRECAST	338	381	648	93	150	162	187	240								
L15	14'-8"	PRESTRESSED	NR	455	780	1003	1325	174	233	2946								
L16	15'-4"	PRESTRESSED	NR	465	765	1310	2045	2610	3185	3765								
L17	17'-4"	PRESTRESSED	NR	NR	NR	NR	NR	NR	NR	NR								
L18	19'-4"	PRESTRESSED	NR	NR	NR	NR	NR	NR	NR	NR								
L19	21'-4"	PRESTRESSED	NR	NR	NR	NR	NR	NR	NR	NR								
L20	22'-0"	PRESTRESSED	NR	NR	NR	NR	NR	NR	NR	NR								
L21	24'-0"	PRESTRESSED	NR	NR	NR	NR	NR	NR	NR	NR								

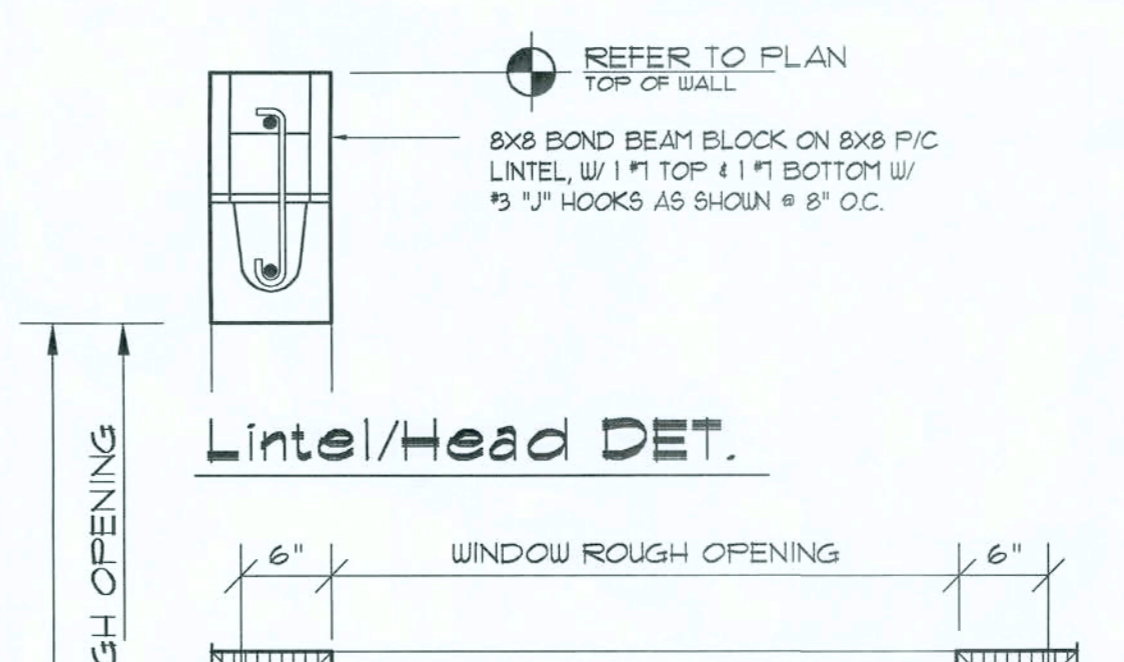

**Lintel/Head DET.**



**Jamb DETAIL**



**Sill DETAIL**

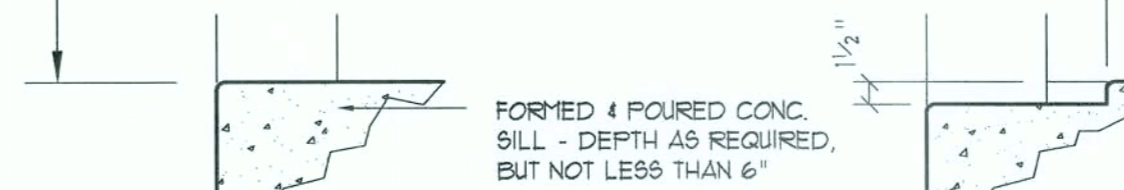

**ENTRY DOOR Sill DETAIL**

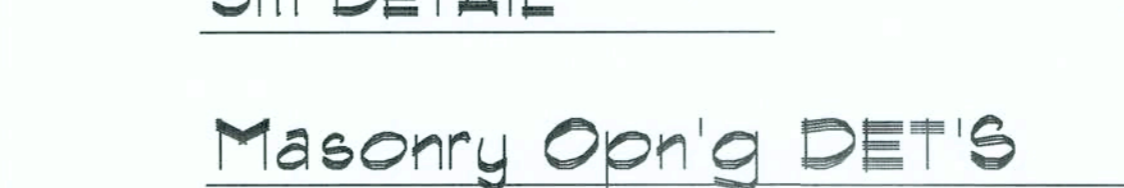

**Garage Door Sill DETAIL**

**Masonry Opn'g DET'S**  
SCALE: 1" = 1'-0"

**8" PRECAST W/ 2" RECESS DOOR U-LINTELS**

MARK	LENGTH	TYPE	8R16	GRAVITY														
				8R16-05	8R16-05	8R16-05	8R16-05	8R16-05	8R16-05	8R16-05	8R16-05							
L12	4'-4"	PRECAST	1489	891	1293	2082	3004	4053	5204	6460								
L13	4'-6"	PRECAST	1351	1449	2182	2714	3600	4681	5751	6764								
L14	5'-8"	PRECAST	785	1187	1842	2560	3420	4481	5751	7114								
L15	5'-10"	PRECAST	135	119	1800	1449	1934	2490	2816	3392								
L16	6'-8"	PRECAST	822	987	1671	2533	3576	4723	5972	7322								
L17	7'-6"	PRECAST	665	807	1371	2233	3280	4430	5681	7031								
L18	8'-8"	PRECAST	571	764	1371	2233	3280	4430	5681	7031								

**CMU WINDOW SCHEDULE**

TYPE	WINDOW LINTEL	ROUGH OPENING	REMARKS
7070 FIXED	100"	85 1/2" X 85 1/2"	STOREFRONT

WINDOWS SHALL BE FASTENED WITH 3/16" PFH TAPCONS W/ MIN. 1 1/2" EMBEDMENT, 6" FROM CORNERS AND 12" O.C. MAX.

**CMU DOOR SCHEDULE**

TYPE	DOOR LINTEL	REMARKS
3068 REAR DR.	54"	PRE-CAST REC.

DOORS SHALL BE FASTENED WITH 3/16" PFH TAPCONS W/ MIN. 1 1/2" EMBEDMENT (14) PER HEAD & SILL, (6) PER JAMB

REVISION:  
DRAWN: DJR

Customer Designed Home for:  
**DANIEL & MICHELLE STAGG**  
COLUMBIA COUNTY, FLORIDA  
**TYPICAL DETAILS**

**APP**  
ARCHITECTURAL DRAFTING & DESIGN, INC.  
Lake City, FL 32055 - 386-752-4670

**NS**  
NICHOLAS PAUL GEISLER ARCHITECT  
1758 NW Brown Rd  
Lake City, FL 32055  
386-752-7521  
N.C.A.R.B. Certified

DATE: 20NOV2007  
COMM:  
SHEET: **A.8**  
8 OF 15

AR0007005

These drawings, as instruments of service, are the sole property of the architect, and may not be used, copied or reproduced in whole or in part for any use or incorporated into any other job without specific and individual authorization by the architect.

"AS-BUILT DRAWINGS" FIELD NOTES

These drawings, as instruments of service, are the sole property of the architect, and may not be used, copied or reproduced in whole or in part for use on or incorporated into any other job without specific and individual authorization by the architect.

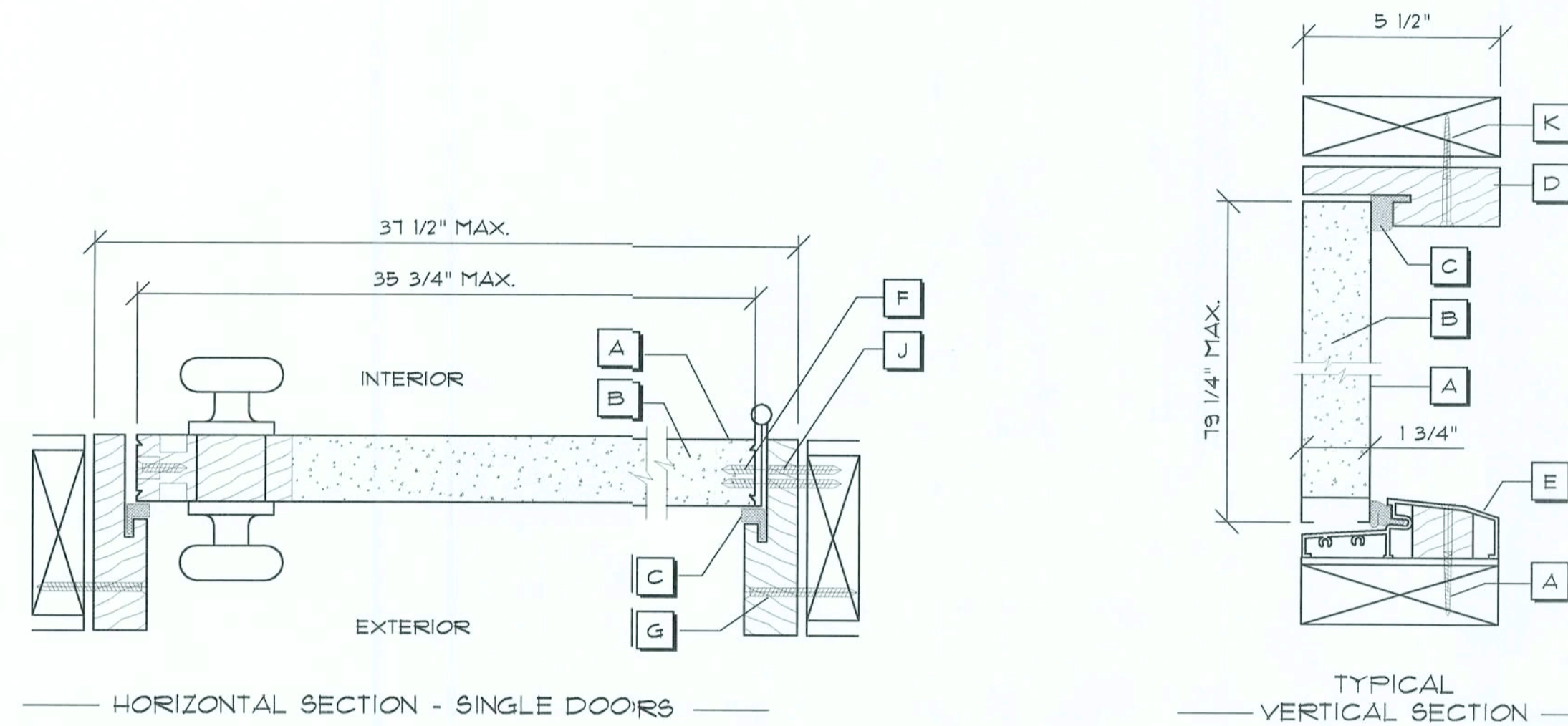

HORIZONTAL SECTION - SINGLE DOORS

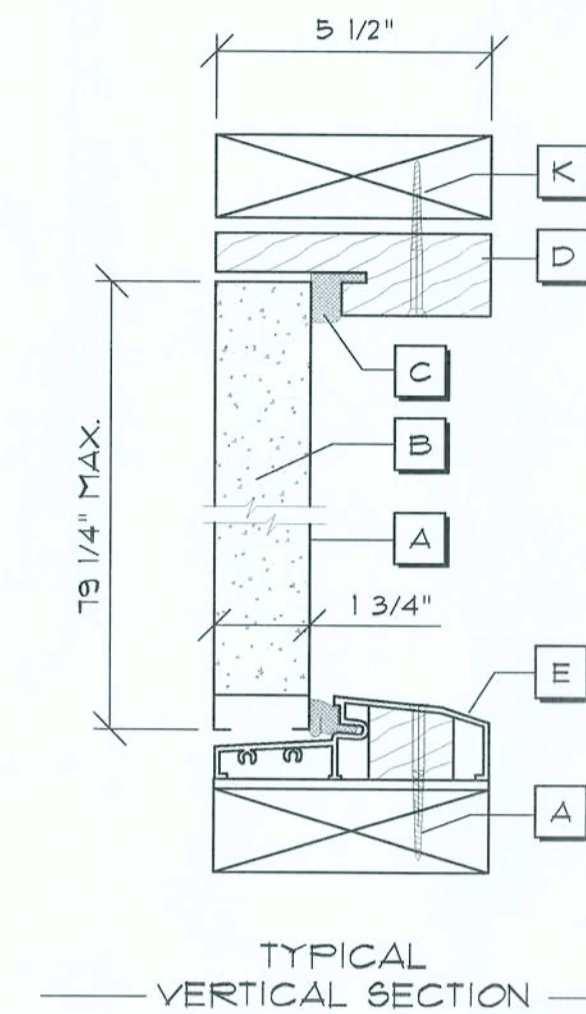

TYPICAL VERTICAL SECTION

NOTE: VERIFY ROUGH OPENING DOOR REQUIREMENTS PRIOR TO CONSTRUCTION.

Typ. Exterior Door Jamb DETAILS

SCALE : NONE

Door Notes

- A STEEL SKIN - 26 GA.
- B POLYURETHANE FOAM CORE
- C COMPRESSION WEATHER STRIP
- D WOOD HEAD JAMB
- E ALUMINUM BUMPER THRESHOLD
- F #10-24 X 1/2" F.H.W.S. (4) SCREWS PER HINGE INTO DOOR
- G #10 X 3" F.H.W.S. (5) SCREWS THROUGH HINGE JAMB, 8" DOWN FROM TOP, MAX. 18" O.C. THEREAFTER.
- H NOT USED
- J #10 X 2" F.H.W.S. (4) SCREWS THROUGH EACH HINGE INTO DOOR JAMB.
- K #10 X 2" F.H.W.S. (2) SCREWS THROUGH HEAD INTO HEADER

DESIGN PRESSURE RATINGS *	
POSITIVE	+16.0 PSF
NEGATIVE	-16.0 PSF

\* WHERE WATER INFILTRATION REQUIREMENT IS NOT NEEDED

NOTE !!!  
EXTERIOR DOORS SHALL MEET OR EXCEED THE WIND RESISTANCE OF THE FOLLOWING PRODUCT:

SERIES ENERGY 6-8 W/E INSWING OPAQUE RESIDENTIAL INSULATED STEEL DOOR W/ STEEL FRAME AS MFG'D BY "FREMDOR ENTRY SYSTEMS"

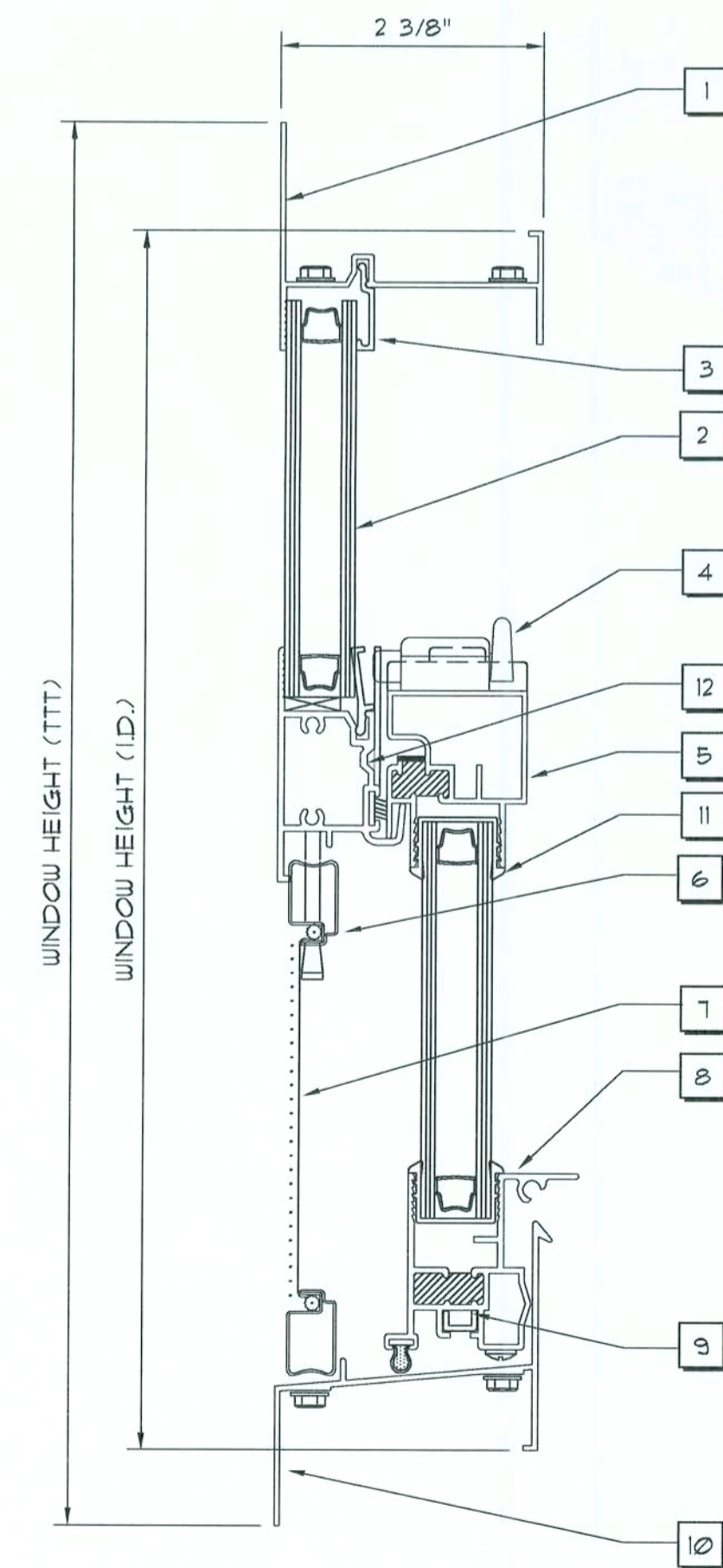

VERTICAL SECTION - SINGLE HUNG WINDOW

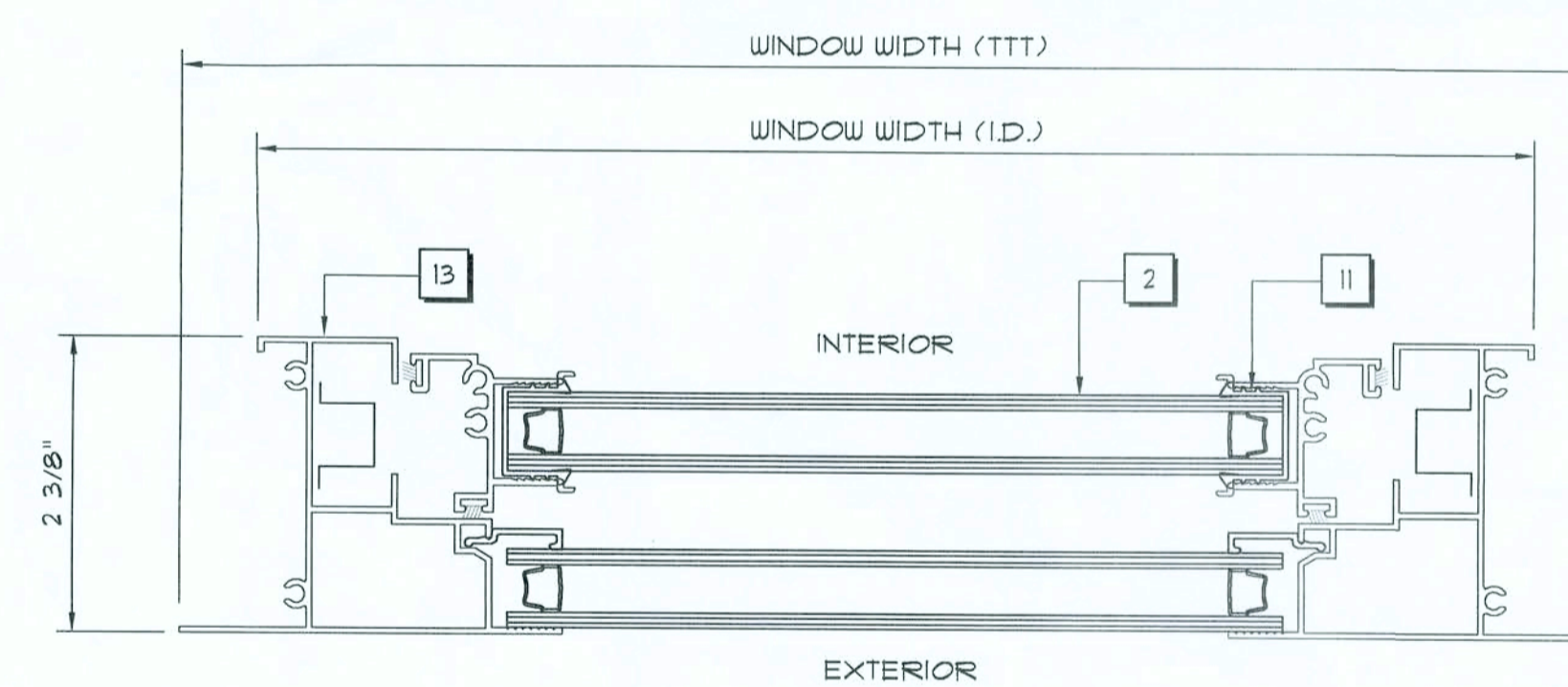

HORIZONTAL SECTION - SINGLE HUNG WINDOW

INSTALLATION	MODEL
1" ROOF'G. NAILS @ 6" FROM CORNERS, 18" O.C.	SERIES 450
5 - 1" ROOF'G. NAILS EA. FLANGE, MAX. 18" O.C.	SERIES 650

NOTE !!!  
ALL WINDOWS ARE INSULATED AND WEATHERSTRIPPED AS MANUFACTURED BY "MI HOME PRODUCTS, INC." - OTHER MANUFACTURERS' PRODUCTS SHALL BE CONSIDERED AS EQUAL IF THEIR WIND DESIGN PERFORMANCE MEETS OR EXCEEDS THESE UNITS.  
NOTE, VERIFY ROUGH OPENING WINDOW REQUIREMENTS PRIOR TO CONSTRUCTION.  
N1 - COMPLETE WITH PAN LITE AS PER SERIES 450  
N2 - TESTING AS PER ASTM E1300

Window Notes

- 1 FLANGED HEAD
- 2 INSULATED GLASS
- 3 GLAZING BEAD
- 4 LOCK
- 5 SASH TOP RAIL
- 6 SCREEN FRAME
- 7 FIBERGLASS MESH
- 8 BOTTOM SASH RAIL
- 9 PIVOT BAR
- 10 FLANGED SILL
- 11 MARINE GLAZING
- 12 FIXED MEETING RAIL
- 13 FLANGED JAMB

Typ. Window Sash DETAILS

SCALE : NONE

REVISION:

Copyright 2005  
N.P. Geiser, Architect

DRAWN:

DJR

Custom Designed Home for:  
**DANIEL & MICHELLE STAGG**  
COLUMBIA COUNTY, FLORIDA  
**EXTERIOR ELEVATIONS**

**ADD**  
ARCHITECTURAL DRAFTING & DESIGN, INC.  
Lake City, FL 32065 • 386/752-8670

**NE**  
NICHOLAS GEISLER  
ARCHITECT  
N.C.A.R.B. Certified  
1728 NW Brown Rd.  
386-752-8021

DATE:

20NOV2007

COMM:

SHEET:

A.9  
9 OF 15

*N. Geiser*  
AR0007005

**GENERAL PLUMBING NOTES:**

1. SUB-CONTRACTORS PROVIDING PLUMBING MATERIALS AND INSTALLATION SHALL BE SUBJECT TO THE PROVISIONS OF NOTES 1 THRU 6.
2. ALL WORKMANSHIP AND MATERIALS SHALL BE IN STRICT ACCORDANCE WITH APPLICABLE LOCAL CODES, RULES AND ORDINANCES.
3. ALL MATERIALS SHALL BE NEW.
4. ALL WORK SHALL BE PERFORMED BY A LICENSED PLUMBING CONTRACTOR IN A FIRST CLASS WORKMANLIKE MANNER. THE COMPLETED SYSTEM SHALL BE FULLY OPERATIONAL.
5. ALL EXCAVATION & BACKFILL AS REQUIRED FOR THIS PHASE OF THE CONSTRUCTION SHALL BE PART OF THE PLUMBING SUB-CONTRACTOR'S RESPONSIBILITIES.
6. PLUMBING FLOOR PLANS AND RISER DIAGRAMS (IF INCLUDED) ARE DIAGRAMATIC. DO NOT SCALE THE DRAWINGS FOR EXACT LOCATIONS OF THE PLUMBING FIXTURES.
7. ALL WORK SHALL BE COORDINATED WITH OTHER TRADES TO AVOID INTERFERENCE WITH THE PROGRESS OF THE CONSTRUCTION.
8. WATER PIPING SHALL BE TYPE L COPPER UP TO 1", & TYPE K FOR ALL LARGER SIZES. ALL UNDERGROUND PIPING SHALL BE TYPE K COPPER. AT THE OWNER'S OPTION SUPPLY PIPING MAY BE C.P.V.C. SCHEDULE 40 OR SCHEDULE 80.
9. DO NOT USE LEAD BASED SOLDER FOR JOINING SUPPLY PIPING.
10. SOIL, WASTE, VENT & RAINWATER PIPING SHALL BE CAST IRON NO-HUB 301-12 ABOVE GRADE WITH NEOPRENE GASKETS AND STAINLESS STEEL BANDS & BELL & SPIGOT CAST IRON BELOW GRADE W/ LEAD & OAKUM JOINTS OR AT THE OWNER'S OPTION, P.V.C. SCHEDULE 40. SEE NOTE 12.
11. AIR CONDITIONING CONDENSATE DRAIN PIPING SHALL BE THREADED STEEL PIPE, COPPER DRAIN, WASTE OR VENT PIPE AND FITTINGS, OR P.V.C. SEE NOTE 12, BELOW. INSULATE ALL CONDENSATE PIPING EXCEPT WHERE UNDERGROUND, AND ELECTRIC HEAT WRAP WHERE EXPOSED TO FREEZING CONDITIONS.
12. P.V.C. SCHEDULE 40 PIPE AND FITTINGS MAY BE USED FOR SOIL, WASTE, VENT, RAINWATER OR CONDENSATE PIPING AS APPROPRIATE, WHERE APPROVED BY LOCAL BUILDING CODES & OFFICIALS. P.V.C. MAY NOT BE USED TO PENETRATE CHASES OR FIRE RATED WALLS / CEILINGS.
13. ALL FIXTURES MUST BE PROVIDED WITH READILY ACCESSIBLE STOPS AND WHERE PROVIDED, MARKED ACCESS PANELS.
14. FURNISH AND INSTALL APPROVED AIR CHAMBERS AT EACH PLUMBING FIXTURE AND APPROVED SHOCK ARRESTERS ON MAIN LINE OR RISERS.
15. DIELECTRIC COUPLINGS ARE REQUIRED BETWEEN ALL DISSIMILAR METALS IN PIPING AND EQUIPMENT CONNECTIONS.
16. ISOLATE COPPER PIPING FROM HANGERS OR SUPPORTS W/ HAIR FELT INSULATOR PADS.
17. PROVIDE 1/2" TRAP PRIMER LINE FOR ALL FLOOR DRAINS FROM NEAREST PLUMBING FIXTURE, DO NOT MANIFOLD.
18. PROVIDE ACCESS PANELS FOR ALL CONCEALED VALVES.
19. PROVIDE COMBINATION COVERPLATE / CLEANOUT PLUG FOR ALL WALL CLEANOUTS, FINISH AS DIRECTED BY THE OWNER.
20. FIXTURES, HARDWARE, EQUIPMENT, COLORS AND FINISHES SHALL BE AS SELECTED BY THE OWNER.

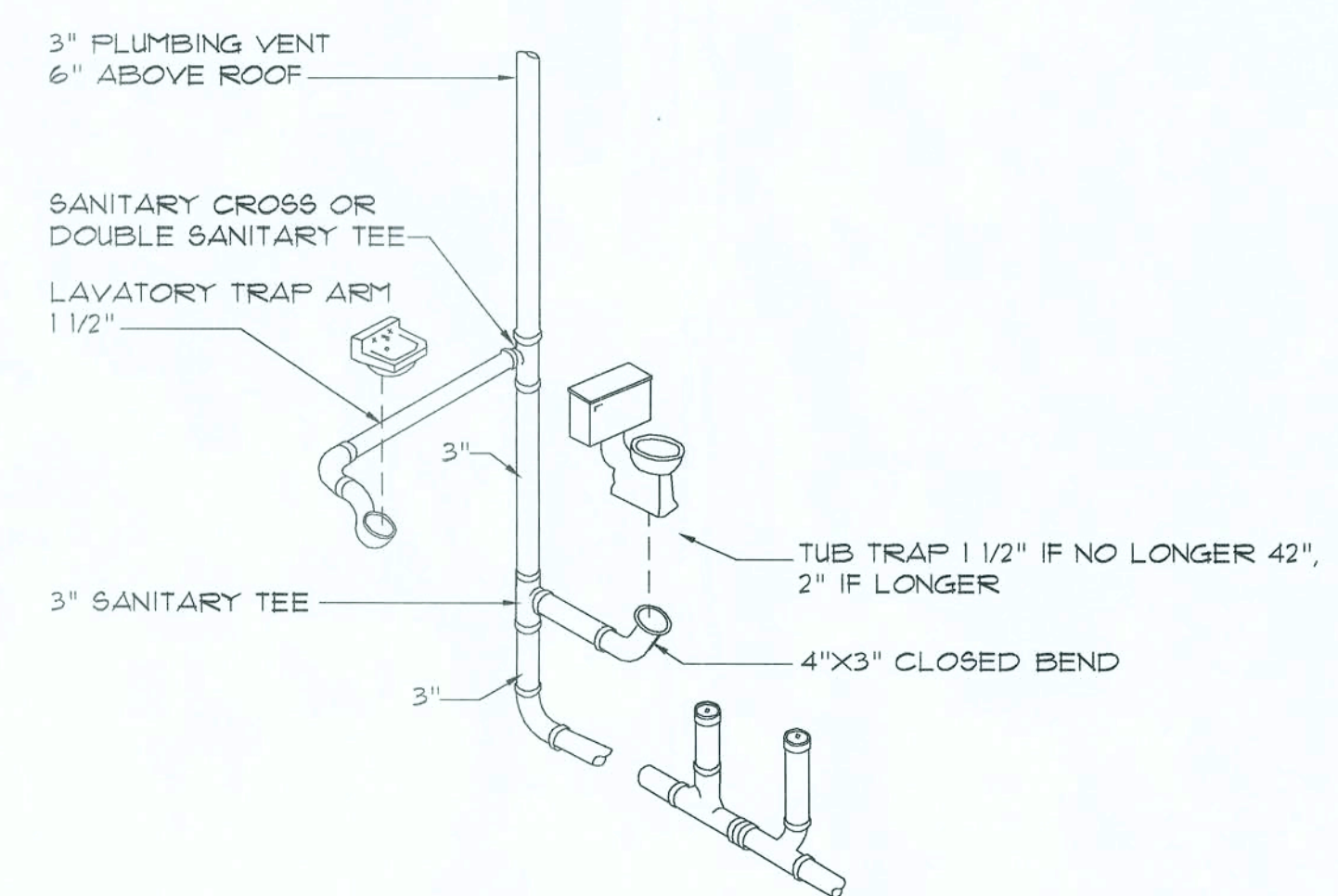
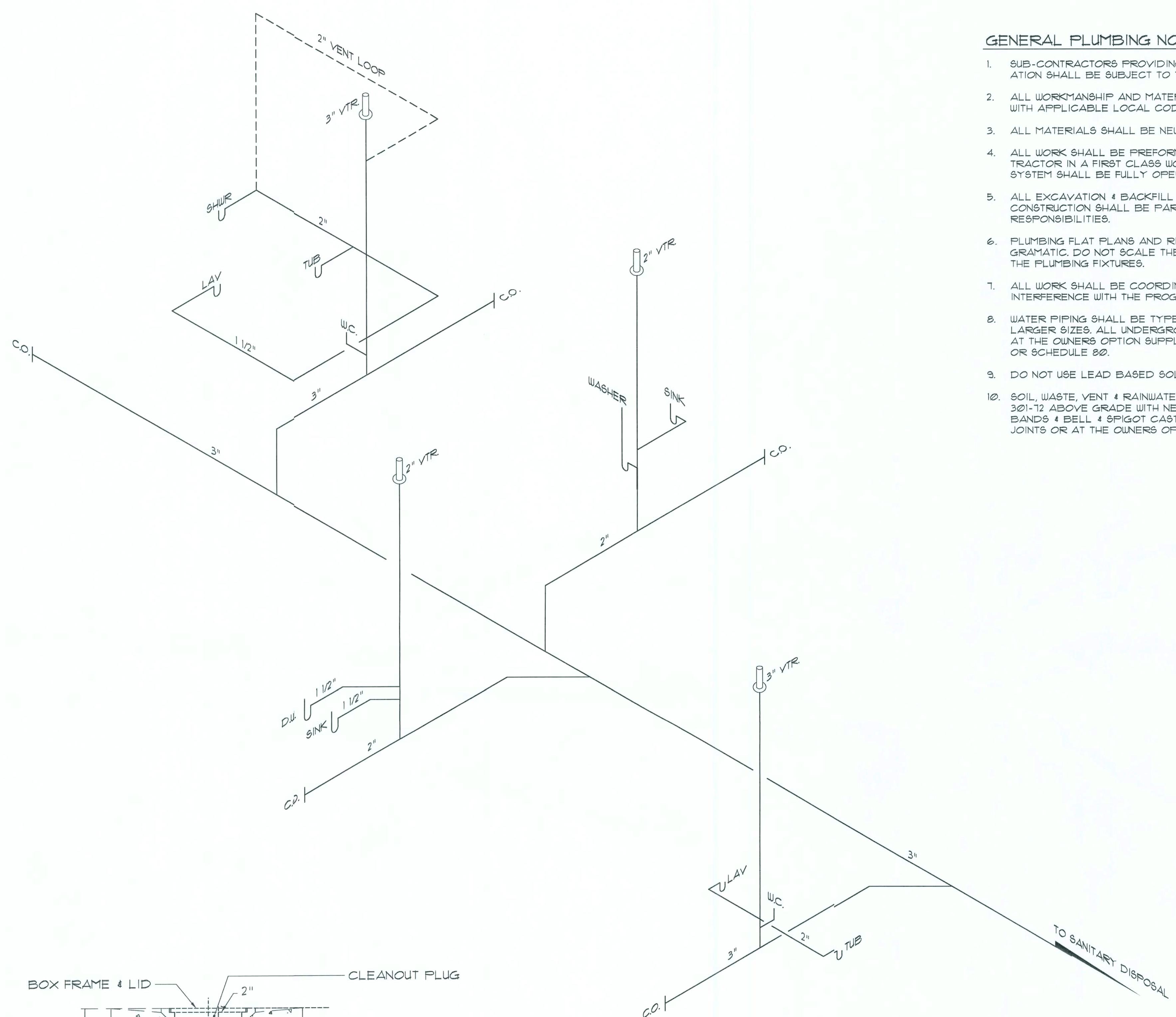

Typ. One Bath Plumbing

N.T.S.  
N.T.S. - THIS PLUMBING DIAGRAM IS GENERAL IN NATURE, REFER TO THE 'PLUMBING RISER DIAGRAM' FOR INFORMATION.

NOTE!  
PLUMBING CONTRACTOR SHALL PREPARE "AS-BUILT" SHOP DRAWINGS INDICATING ALL PLUMBING WORK INCLUDING ALL PLUMBING LINE LOCATIONS AND RISER DIAGRAM - CONTR SHALL PROVIDE 1 COPY OF AS-BUILT DIAGS TO OWNER AND 1 COPY TO THE PERMIT ISSUING AUTHORITY.

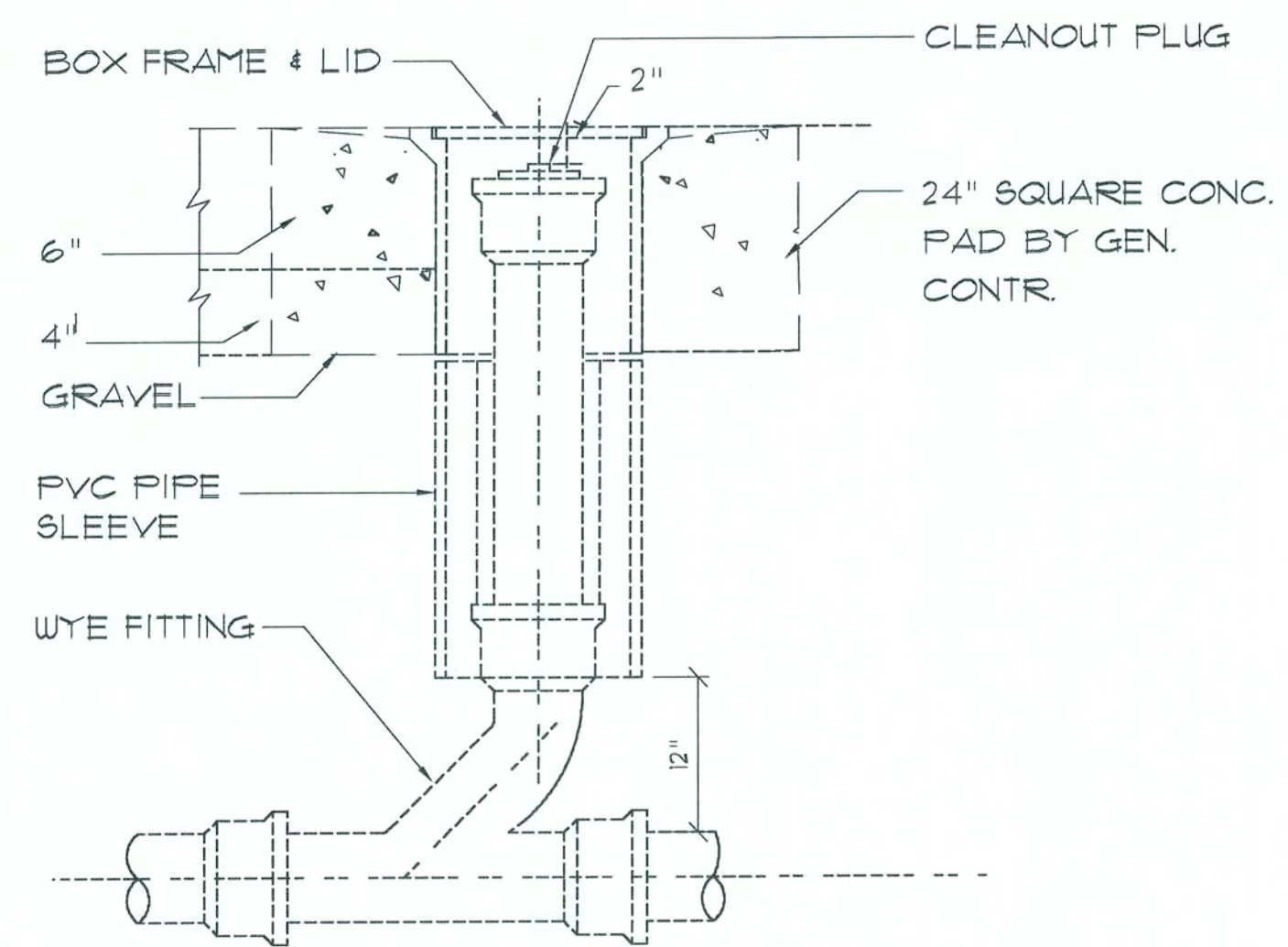

Outdoor Cleanout  
N.T.S.

**Plumbing Riser DIAGRAM**

SCALE: NONE

These drawings, as instruments of service, are the sole property of the architect, and may not be used, copied or reproduced in whole or in part for use on or incorporated within any other job without specific and individual authorization by the architect.

These drawings, its instruments of service, are the sole property of the architect, and may not be used, copied or reproduced in whole or in part for use on or incorporated within any other job without specific and individual authorization by the architect.

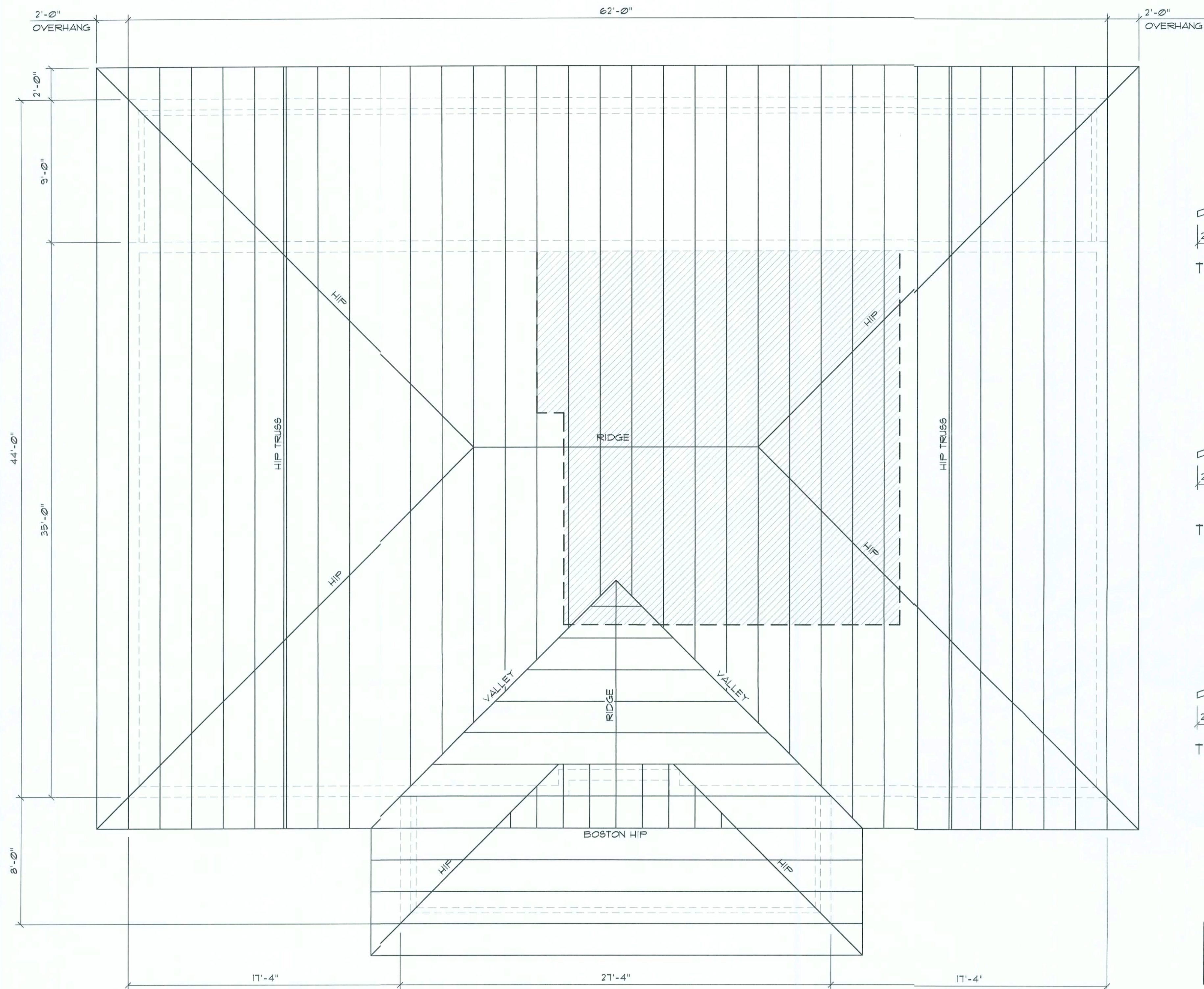

**Roof Framing PLAN**

SCALE: 1/4" = 1'-0"

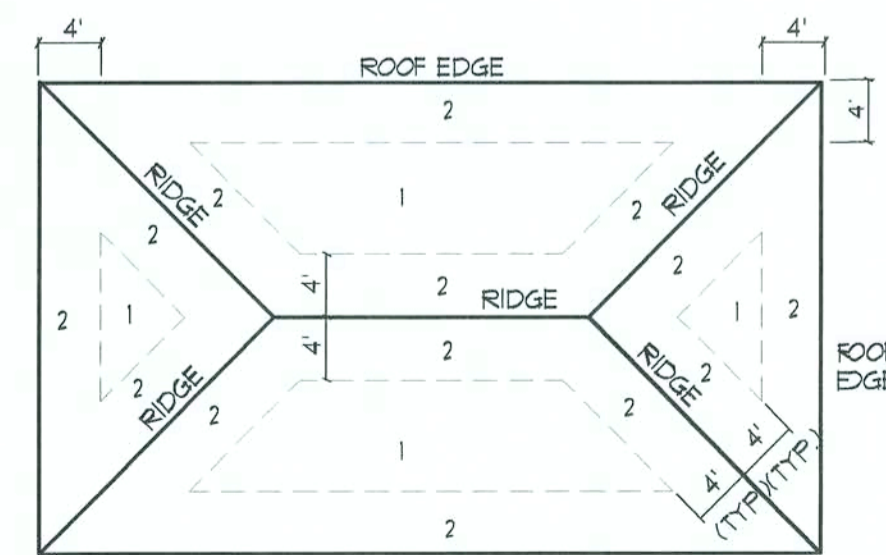

ROOF SHEATHING NAILING ZONES (HIP ROOF)

**Roof Nail Pattern**

SCALE: NONE

ROOF SHEATHING FASTENINGS			
NAILING ZONE	SHEATHING TYPE	FASTENER	SPACING
1	5/8" CD PLYWOOD	10d COMMON OR 10d HOT DIPPED GALVANIZED BOX NAILS	6 in. o.c. EDGE 12 in. o.c. FIELD
2			6 in. o.c. EDGE 12 in. o.c. FIELD
3			4 in. o.c. GABLE ENDWALL OR GABLE TRUSS 6 in. o.c. EDGE 12 in. o.c. FIELD

SHOP DRAW COORDINATION: THE TRUSS ANCHOR STRAPS AS INDICATED IN THE CONSTRUCTION DOCUMENTS ARE SUGGESTED STRAPS AND THAT THE TRUSS ENGINEERED SHOP DRAWING LOADS TAKE PRECEDENCE OVER THAT INDICATED IN THE CONSTRUCTION DOCUMENTS.

THE UPLIFT LOADS INDICATED FOR EACH TRUSS IN THE ENGINEERED TRUSS SHOP DRAWINGS MAY BE MATCHED TO STANDARD PRODUCT UPLIFT RATINGS FOR COMPARABLE UPLIFT CONNECTORS, AND THAT THE PRODUCTS THAT PROVIDE EQUAL OR GREATER UPLIFT RESISTANCE FOR THE LISTED LOADS MAY BE USED IN LIEU OF THOSE INDICATED IN THE CONSTRUCTION DOCUMENTS OR AS APPROVED BY THE BUILDING OFFICIAL.

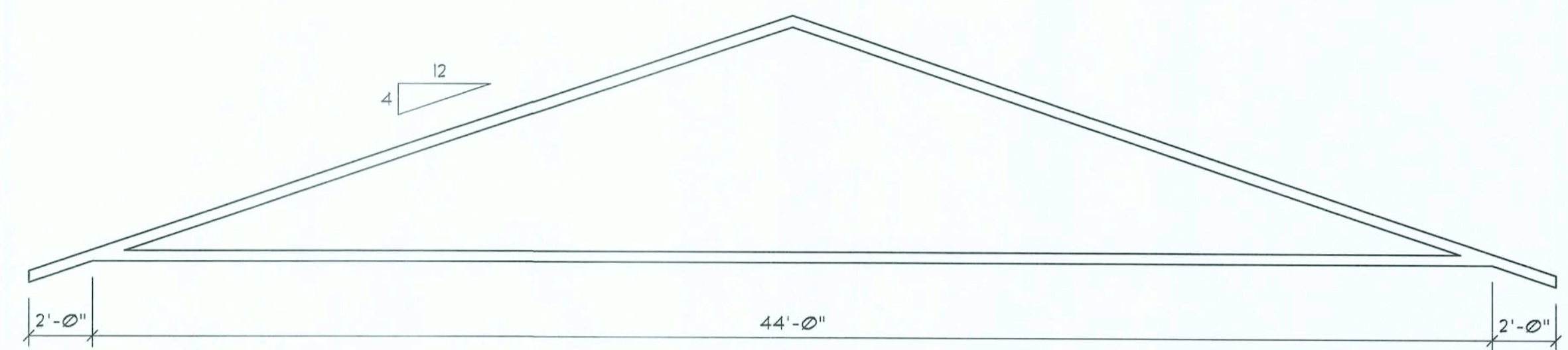

TYPE I - COMMON

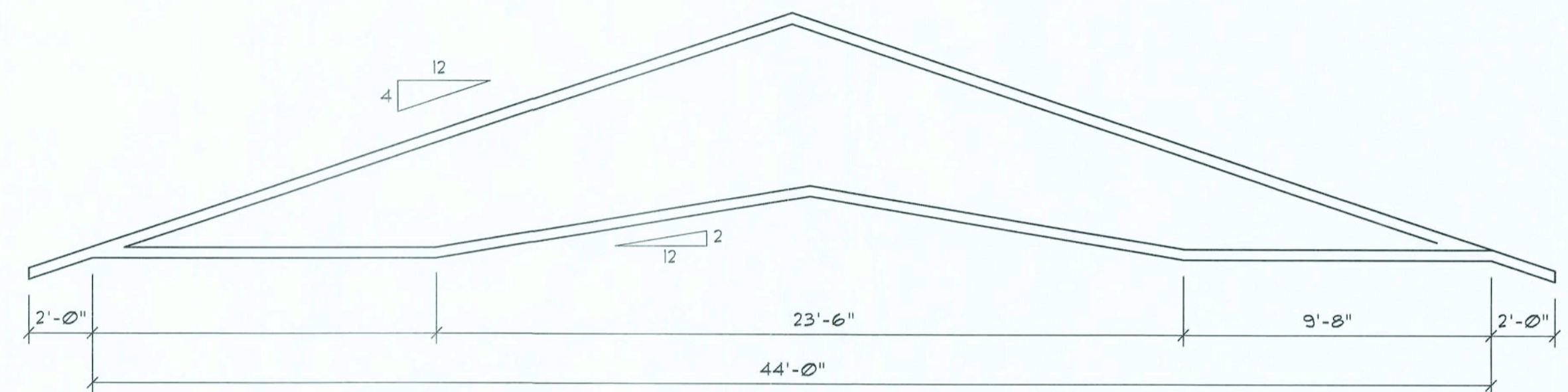

TYPE II - SCISSOR

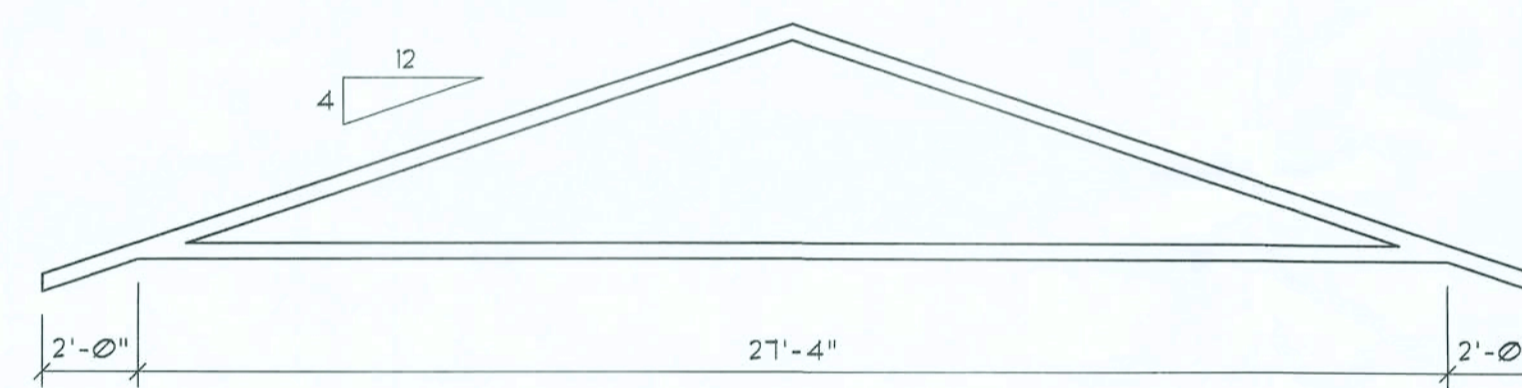

TYPE III - COMMON

**Truss Profiles**

SCALE: 1/4" = 1'-0"

DENOTES: CATHEDRAL CEILING W/2:12 SLOPE ON BOTTOM SIDE SEE 'FLOOR PLAN'

**WOOD STRUCTURAL NOTES**

- TEMPORARY BRACING OF THE STRUCTURE DURING ERECTION, REQUIRED FOR SAFE AND STABLE CONSTRUCTION, SHALL BE THE SOLE RESPONSIBILITY OF THE CONTRACTOR SO ENGAGED. TEMPORARY AND PERMANENT BRACING OF ROOF TRUSSES SHALL BE AS PER THE STANDARD GUIDELINES OF THE "TRUSS PLATE INSTITUTE".
- ALL TRUSSES SHALL BE DESIGNED BY A LICENSED PROFESSIONAL ENGINEER & SHALL BE SIGNED AND SEALED BY THE SAME. TRUSS DESIGN SHALL INCLUDE ALL PLACEMENT PLANS, TRUSS DETAILS, TRUSS TO TRUSS CONNECTIONS & THE STANDARD SPECIFICATIONS AND RECOMMENDATIONS OF INSTALLATION OF THE "TRUSS PLATE INSTITUTE".
- THE DESIGN WIND SPEED FOR THIS PROJECT IS 110 MPH PER THE 2004 FLORIDA BUILDING CODE SECTION 1609 AND LOCAL JURISDICTION REQUIREMENTS.
- SHEATH ROOF WITH 5/8" CDX PLYWOOD W/LONG EDGE PERPENDICULAR TO THE ROOF TRUSSES, SECURE TO FRAMING WITH 10d NAILS SPACED PER THE NAILING SCHEDULE.

REVISION:

Copyright 2005  
N.F. Gelsler, Architect

DRAWN:

DJR

Custom Designed Home for:  
**DANIEL & MICHELLE STAGG**  
COLUMBIA COUNTY, FLORIDA  
**ROOF FRAMING PLAN**

**APP**  
ARCHITECTURAL DRAFTING & DESIGN, INC.  
LANE CITY, FL 32055 - 386.782.4670

**NS**  
NICHOLAS PAUL GEISLER ARCHITECT  
1758 NY P.C.# 2055  
LANE CITY, FL 32055  
386-755-9021  
N.C.A.R.T.B. Certified

DATE:

20NOV2011

COMM:

SHEET:

A.11

11 OF 15

13DEC2011  
AR0007005

These drawings, or instruments of service, are the sole property of the architect, and may not be used, copied or reproduced in whole or in part, for use on or incorporated into any other job without specific and exclusive authorization by the architect.

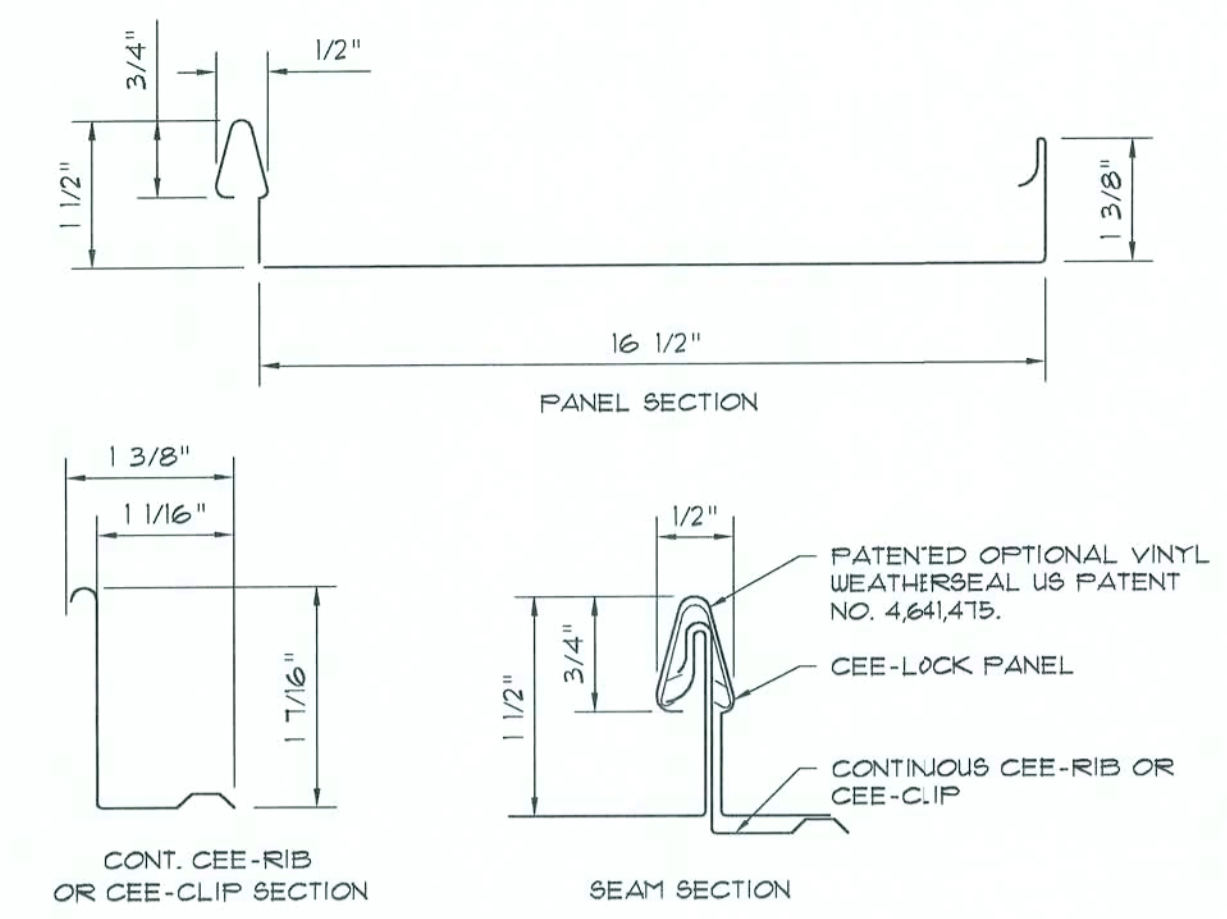

**PANEL DETAIL**  
SCALE: NONE

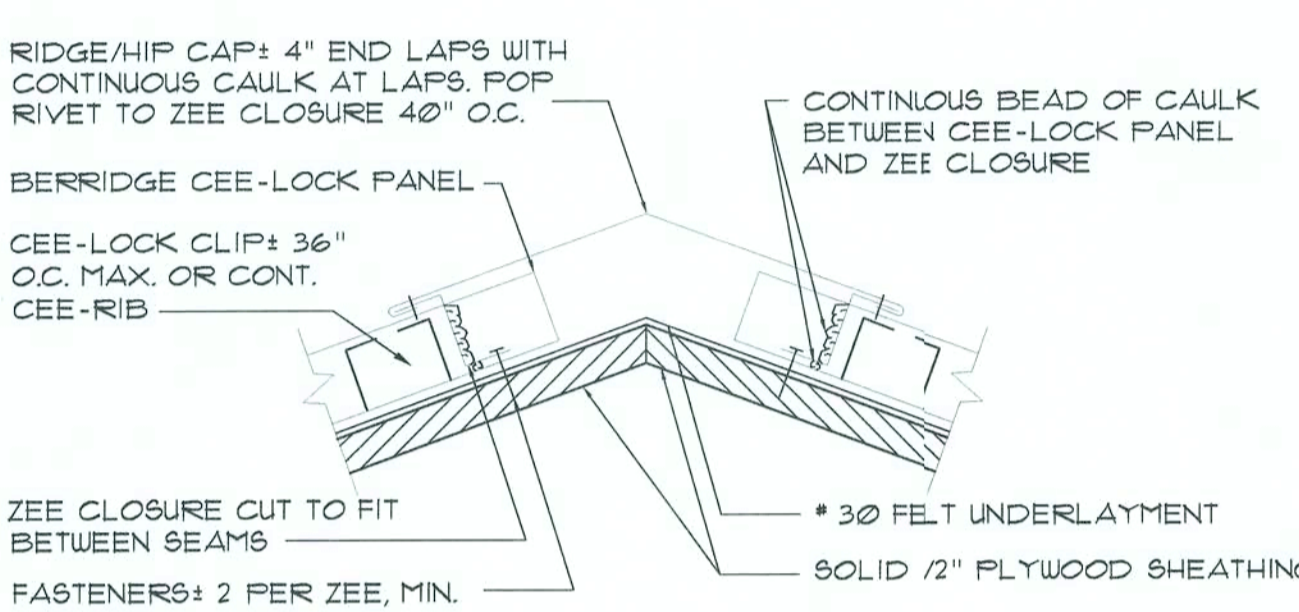

**RIDGE/HIP DETAIL**  
SCALE: NONE

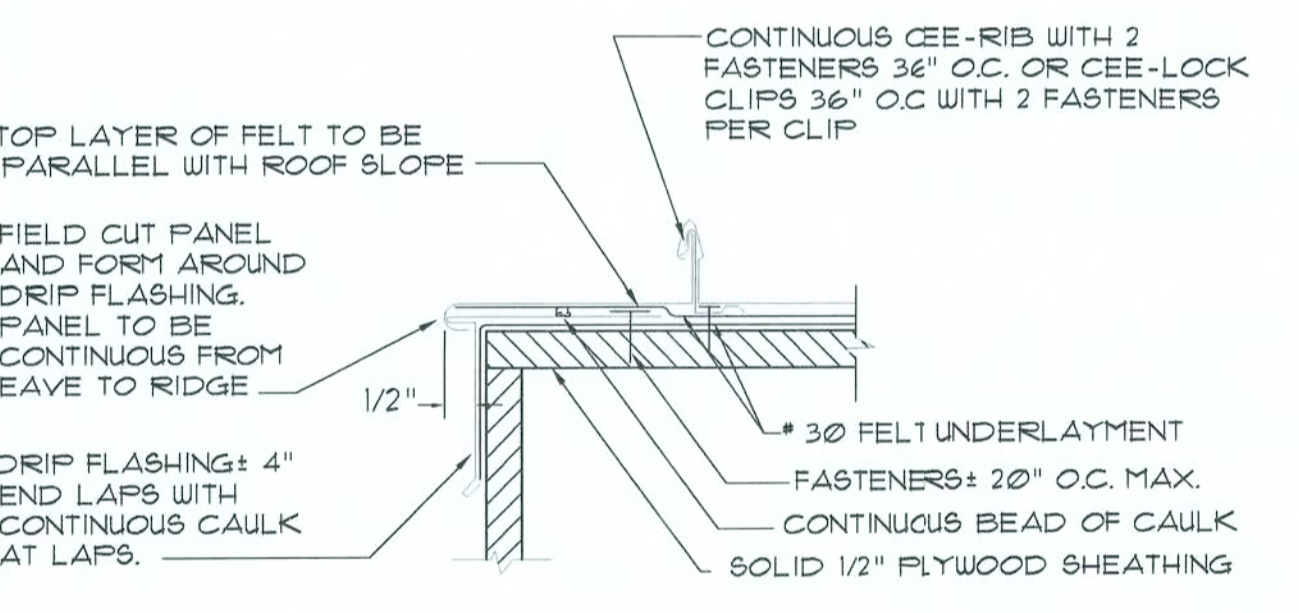

**GABLE DETAIL / PANEL TURNDOWN**  
SCALE: NONE

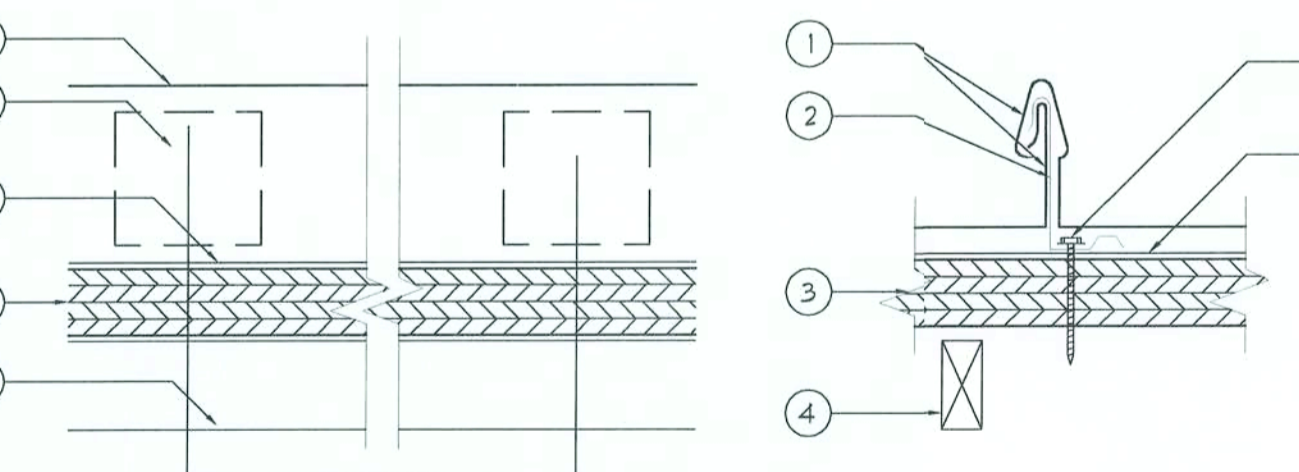

- CEE-LOCK PANEL - NO. 24 M6G (MIN. YIELD STRENGTH 40000 PSI) THICKNESS COATED STEEL, 16 1/2 IN. WIDE 1 1/2 IN. HIGH, PANEL (NON-STRUCTURAL VINYL WEATHER SEAL OPTIONAL IN SEAM) CONTINUOUS OVER TWO OR MORE SEAMS WITHOUT LAPS.
- CEE-CLIP (PANEL CLIP) - ONE PIECE ASSEMBLY FABRICATED FROM NO. 24 M6G (MIN. YIELD STRENGTH 40000 PSI) COATED STEEL, CEE-CLIP LOCATED AT EACH PANEL SIDE LAPS BEING PLYED AT 3'-0" O.C. MAXIMUM
- DECK - 5/8" APA 40/20 PLYWOOD.
- JOIST - 2" X 4" AT 2'-0" O.C. MAXIMUM WITH #12 X 2" PAN HEAD WOOD SCREW AT 12" O.C. MAX. AT PLYWOOD TO JOIST CONNECTION AND AT PLYWOOD ENDS.
- \* 30 FELT UNDERLAYMENT.
- FASTENERS (SCREWS) - FOR ATTACHING "CEE-CLIP" (ITEM TWO) TO DECK USE NO. 10 PANCAKE HEAD TEKS STEEL SCREWS, TWO FASTENER PER "CEE-CLIP".

**CLIP FASTENER DETAIL**  
SCALE: NONE

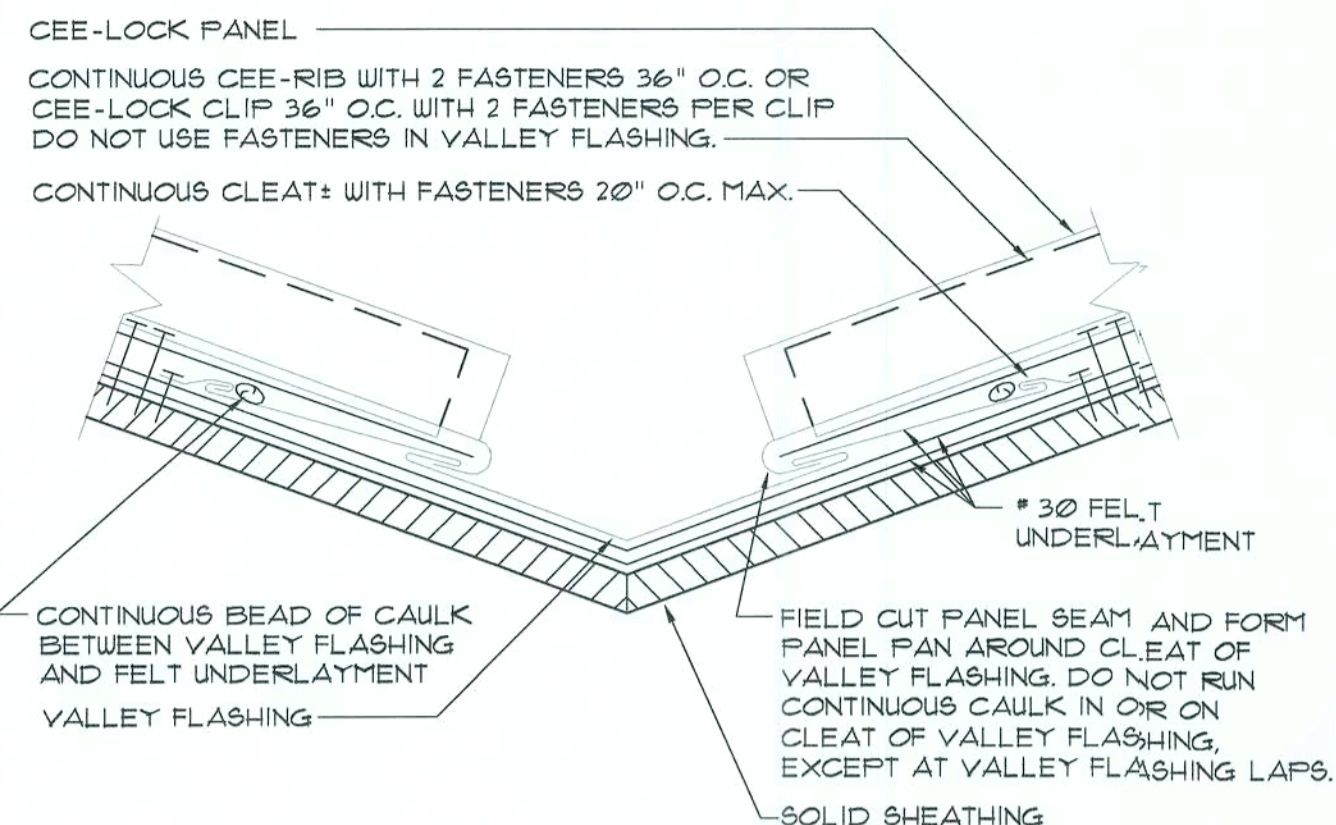

**VALLEY DETAIL**  
SCALE: NONE

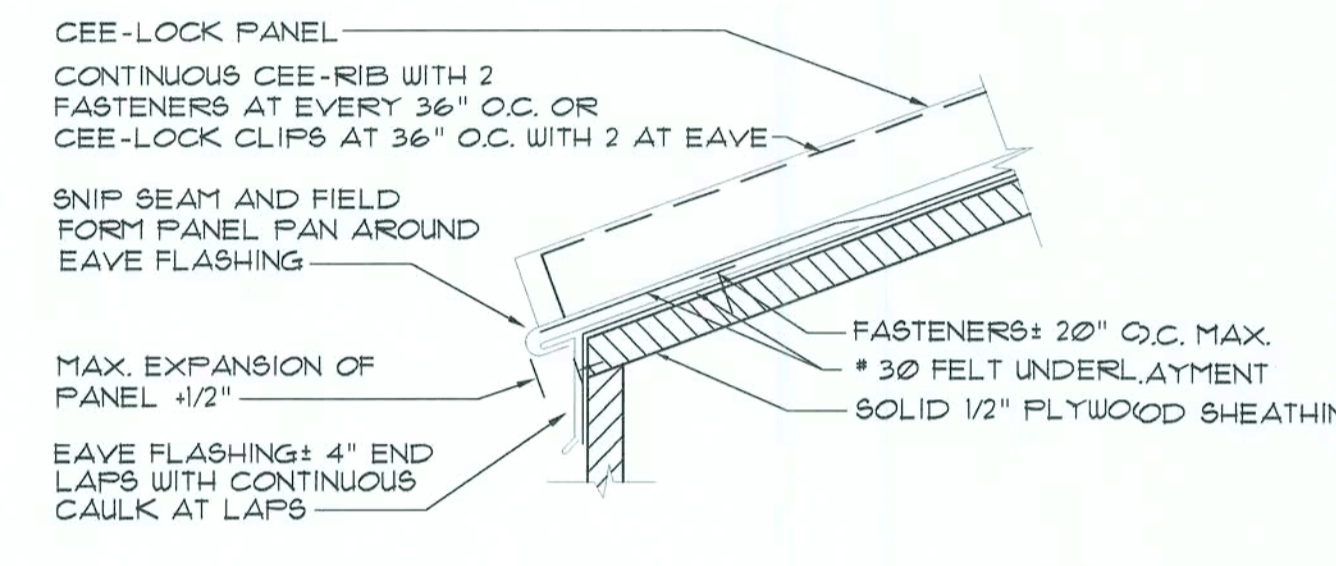

**EAVE DETAIL**  
SCALE: NONE

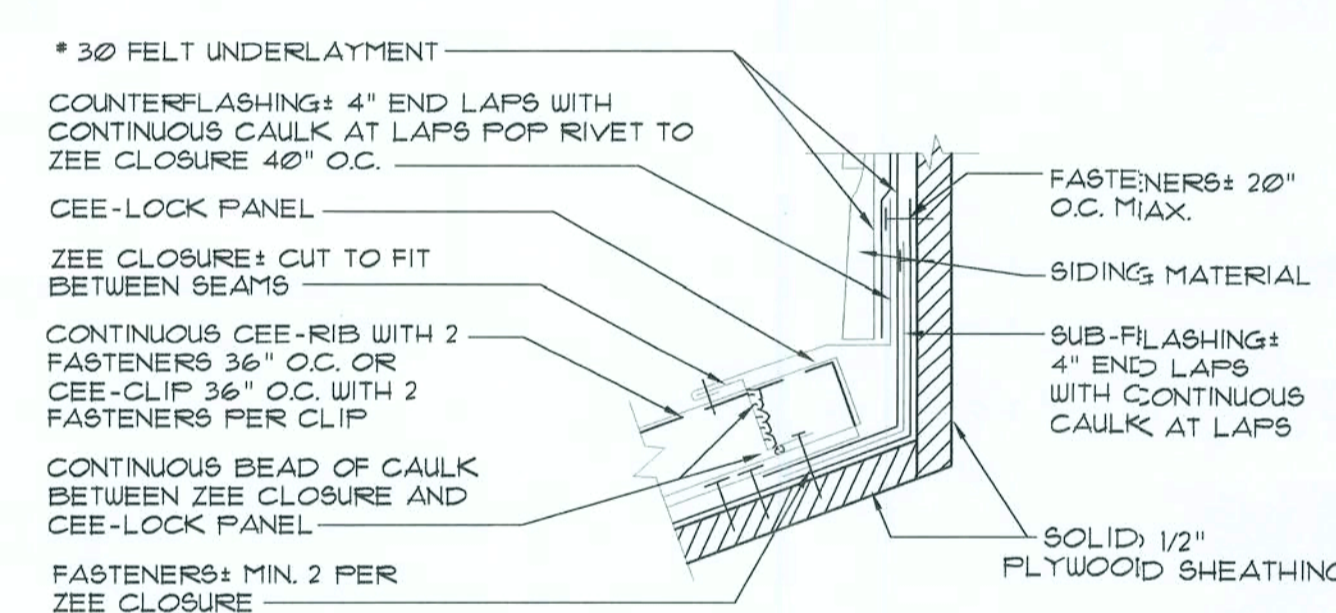

**FLASHING DETAIL**  
SCALE: NONE

NOTE: ALL FELT UNDERLAYMENT, CAULKING, AND FASTENERS SHALL BE FURNISHED AND INSTALLED BY THE ROOFING INSTALLER.

ALL ARCHITECTURAL PANELS ARE 24 GAUGE METAL, TAKE CARE IN HANDLING AND INSTALLATION TO AVOID DAMAGING OR DEFORMING THE PANELS.

**NOTE:**

THE STANDING SEAM METAL ROOF SYSTEM SHALL COMPLY WITH BERRIDGE MANUFACTURING COMPANY'S SPECIFICATIONS & DETAILS AS SHOWN ON THIS DRAWING, OR AN APPROVED PRODUCT OF EQUAL DESIGN.

BERRIDGE MANUFACTURING COMPANY  
1120 MAURY STREET  
HOUSTON, TX 77026  
1-800-231-2121  
<http://www.berridge.com>

APPROVED ALTERNATE:

ENGLERT, INC.  
1200 AMBOY AVENUE  
PERTH AMBOY, NJ 08862  
1-800-610-1915  
<http://www.englertinc.com>

**STANDING SEAM PANEL INSTALLATION NOTES**

- DOUBLE LAYER OF NUMBER THIRTY FELT UNDERLAYMENT OR EQUAL AND THE CEE-LOCK OPTIONAL VINYL WEATHERSEAL (US PATENT NO. 4,641,415) ARE RECOMMENDED FOR ALL APPLICATIONS WHERE THE ROOF SLOPE IS 3 ON 12 OR LESS.
- STRIPPABLE FILM: THE STRIPPABLE PLASTIC FILM WHICH IS APPLIED OVER MOST BERRIDGE PREFINISHED PRODUCTS, PANELS, FLASHINGS, COILS, AND FLAT SHEETS PROVIDES PROTECTION OF THE FINISH DURING FABRICATION AND TRANSIT. THIS FILM MUST BE REMOVED PRIOR TO INSTALLATION.
- SOLID SHEATHING REQUIREMENTS: 5/8" PLYWOOD SHEATHING SHALL BE USED TO PROVIDE SUFFICIENT HOLDING POWER FOR FASTENERS.
- SHEATHING INSPECTION:
  - SHEATHING END JOINTS SHOULD BE STAGGERED.
  - ALL END JOINTS SHOULD MEET AT EITHER A JOIST OR RAFTER.
  - BLOCKING OR "H" CLIPS SHOULD BE USED IF JOISTS DO NOT REMAIN FLAT UNDER THE WEIGHT OF WORKMEN.
  - USE SHIMS TO KEEP ENTIRE SUBSTRATE EVEN, UNEVEN SUBSTRATE WILL RESULT IN "OIL-CANNING" IN PANELS. SUBSTRATE SHOULD BE LEVEL TO 1/4" IN 20'-0".
  - ALL CUTS AT PENETRATIONS SHOULD BE TIGHT, WITHOUT GAPS.
  - USE WOOD-FRAMED CRICKETS AT LARGE PENETRATIONS.
  - MAKE SURE SUBSTRATE JOINTS ARE TIGHT AT ALL HIPS, VALLEYS, AND RIDGES.
- FASCIA/RAKE INSPECTION:
  - STRIKE A LINE THE FULL LENGTH OF THE FASCIA OR RAKE. IF NOT STRAIGHT, CORRECT WITH SHIMS.
  - MAKE SURE FASCIA/RAKE IS FLUSH WITH SHEATHING.
- FELT UNDERLAYMENT: A MINIMUM SINGLE LAYER OF # 30 FELT UNDERLAYMENT (OR EQUAL) MUST BE APPLIED OVER SOLID SHEATHING AS SHOWN IN THE BERRIDGE MANUFACTURING COMPANY TYPICAL FELTING DETAILS. THE USE OF ADDITIONAL LAYERS OF # 30 FELT IS RECOMMENDED ON LOW SLOPED ROOFS, AT ALL VALLEY CONDITIONS, AT ROOF PENETRATIONS, AND CERTAIN OTHER FLASHING CONDITIONS AS DEPICTED IN THE CEE-LOCK PANEL TYPICAL DETAILS. (THE UNDERLAYMENT MUST COVER THE ENTIRE ROOF DECKED SURFACE).
- FELTING INSTALLATION:
  - DO NOT USE RED ROBIN PAPER UNDER METAL ROOFING PANELS.
  - SWEEP ROOF AREA CLEAN.
  - USE FLAT HEAD GALVANIZED ROOFING NAILS x 1 1/4" LONG WITH BERRIDGE GALVANIZED FELT CAPS.
  - INSTALL VALLEY FELT FIRST.
  - INSTALL FELT PARALLEL TO EAVE (2 LAYERS REQUIRED AT EAVE), STARTING AT EAVE AND USING MINIMUM 6" LAPS. USE TWO LAYERS OF FELT ON ENTIRE ROOF DECK IF ROOF SLOPE IS 3 ON 12 OR LESS. 2 LAYERS OF FELT REQUIRED AT EAVE REGARDLESS OF SLOPE.
- FLASHING: IF BERRIDGE MANUFACTURING COMPANY IS TO SUPPLY FLASHINGS, ALL FLASHINGS WILL BE FABRICATED IN 10'-0" LENGTHS WITH SQUARE END CUTS ONLY. THE PURCHASER MUST PROVIDE ALL DIMENSIONS AND DEGREE OF ANGLES.
- FLASHING INSTALLATION:
  - REMOVE STRIPPABLE PLASTIC FILM FROM ALL FLASHINGS PRIOR TO INSTALLATION.
  - ALWAYS STAGGER JOINTS WHEN ONE FLASHING IS INSTALLED OVER OTHER FLASHING.
  - INSTALL ALL FLASHINGS AS PER BERRIDGE TYPICAL DETAILS.
  - ALL FLASHINGS ARE TO BE DESIGNED AND INSTALLED TO NOT TRAP WATER.
- PANEL INSTALLATION:
  - REMOVE STRIPPABLE PLASTIC FILM FROM EACH PANEL PRIOR TO INSTALLATION.
  - START PANEL INSTALLATION AT ON GABLE END OF THE ROOF, WORKING TOWARD THE OTHER GABLE END, MAKE SURE PANELS ARE PERPENDICULAR TO THE EAVE. AT VALLEY AREAS, MAKE SURE PANELS ARE INSTALLED SO THAT DRAINAGE HAS FREE FLOW AND IS NOT OBSTRUCTED BY PANEL SEAMS.
  - BEGIN BY INSTALLING J-CLIP AND/OR DRIP FLASHING AT GABLE THEN PLACING FIRST CEE-LOCK CONTINUOUS LENGTH PANEL.
  - INSTALL CEE-LOCK CLIPS OR CONTINUOUS CEE-RIB AS PER BERRIDGE TYPICAL DETAILS AND CEE-LOCK CONTINUOUS RIB/CLIP INSTALLATION NOTES.
  - IF OPTIONAL VINYL WEATHERSEAL (US PATENT 4,641,415) IS TO BE USED, THIS WILL BE EITHER FACTORY INSTALLED OR INSTALLED IN THE FIELD AS THE CEE-LOCK PANEL EXITS FROM THE CL-21 PORTABLE ROLL FORMER.
  - INSTALL PANELS BY PLACING THE FEMALE LEG OVER THE MALE LEG AND CONTINUOUS CEE-RIB OR CLIP AND SHAPING THE INTEGRAL SEAM INTO PLACE WITH HAND PRESSURE. DO NOT USE EXCESSIVE FORCE, FOOT PRESSURE OR OTHER TOOLS SUCH AS MALLETS AS THIS WILL SCRATCH OR DENT THE PANEL RIB AND CAUSE DEFORMATION TO THE VINYL WEATHERSEAL.
  - EACH PANEL IS TO BE KEPT TIGHT AGAINST THE LEG OF THE ADJOINING PANEL. NEVER PERMIT A GAP BETWEEN VERTICAL LEGS.
  - KEEP PANELS ALIGNED SO THAT SEAMS MATCH AT HIPS, VALLEYS AND WHERE VERTICAL PANELS ADJOIN ROOF PANELS. DO NOT INSTALL LONG CONTINUOUS RUNS OF PANELS ALL AT ONE TIME WHERE SEAM LINES MUST MATCH. INSTALL TEN OR TWELVE PANELS IN ONE ELEVATION AND THEN FOLLOW WITH A LIKE NUMBER OF PANELS ON THE OTHER ELEVATION WHEN YOU INSTALL PANELS IN THIS MANNER, YOU WILL BE ABLE TO MAKE ANY ADJUSTMENTS REQUIRED TO INSURE SEAM MATCHING.
  - COPPER-COTE, CHAMPAGNE, LEAD-COTE, AND PREWEATHER GALVALUME PANEL INSTALLATION: NOTE THE SERIES OF ARROWS PAINTED ON THE UNDERSIDE OF THE PANEL. ALL PANELS MUST BE INSTALLED IN CONSISTENT MANNER, MEANING THAT THE ARROWS ON EVERY PANEL ARE ALL POINTING IN THE SAME DIRECTION. IF A PANEL IS REVERSED (ARROW POINTING OPPOSITE OF THOSE ON OTHER PANELS) IT WILL APPEAR FROM A DISTANCE A DIFFERENT SHADE DUE TO THE GRANULAR OF THE PIGMENTS IN THE FINISH. METALLIC FINISHES ARE MATCH - LOT FINISHES. DO NOT MIX LOTS.
- CEE-LOCK CLIP INSTALLATION:
  - INSTALL CLIPS AT PER BERRIDGE TYPICAL CEE-LOCK PANEL DETAILS.
  - CLIP SPACING ON SOLID SHEATHING TYPICALLY 36" ON CENTER.
- FASTENERS: PLATED FASTENERS WHEN FASTENING TO WOOD. MAKE SURE ALL FASTENERS ARE DRIVEN STRAIGHT AND SET FLAT. DO NOT OVERDRIVE FASTENERS AS THIS WILL CAUSE THE CLIP AND/OR FLASHINGS TO BUCKLE OR BECOME RECESSED BELOW THE ELEVATION OF THE SUBSTRATE.
- SEALANT RECOMMENDATIONS: TREMCO, INC. SPECTREM I SILICONE SEALANT. DO NOT USE CLEAR CAULK.

5M-RIB METAL ROOFING PANELS  
ALTERNATE FASTENER SCHEDULE FOR VARIOUS WIND VELOCITIES  
MANUFACTURER'S RECOMMENDED FASTENER SCHEDULE  
FOR BUILDINGS W/ $<35'$  MEAN ROOF HEIGHT, MIN. 3/2 PITCH  
BASED ON ASCE 7-98, EXPOSURE "C"

ROOF ZONE	FASTENER TYPE	FASTENER SIZE	PLACEMENT TO	100 - 110		120 - 130		140 - 150	
				O/C SPACING	TRIM	O/C SPACING	TRIM	O/C SPACING	TRIM
1	WD. SCREW	#9 X 1 1/2"	WOOD	36"	18"	24"	12"	24"	12"
	MTL. SCR.	#12 X 1" #14 X 1 1/8"	< 18 GA > 18 GA	36"	18"	24"	12"	24"	12"
2 & 3	WD. SCREW	#9 X 1 1/2"	WOOD	36"	18"	24"	12"	24"	8"
	MTL. SCR.	#12 X 1" #14 X 1 1/8"	< 18 GA > 18 GA	36"	18"	24"	12"	24"	8"

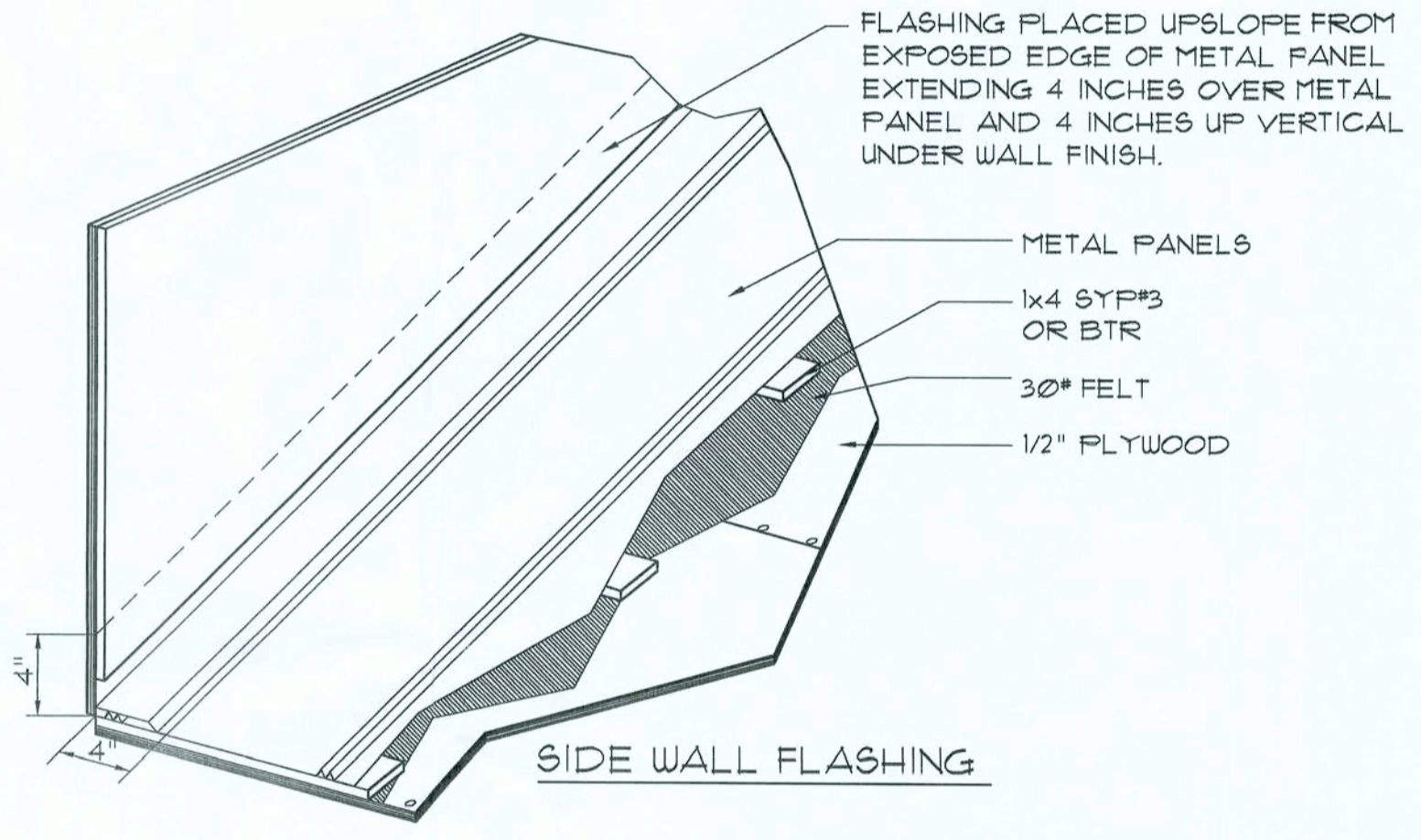
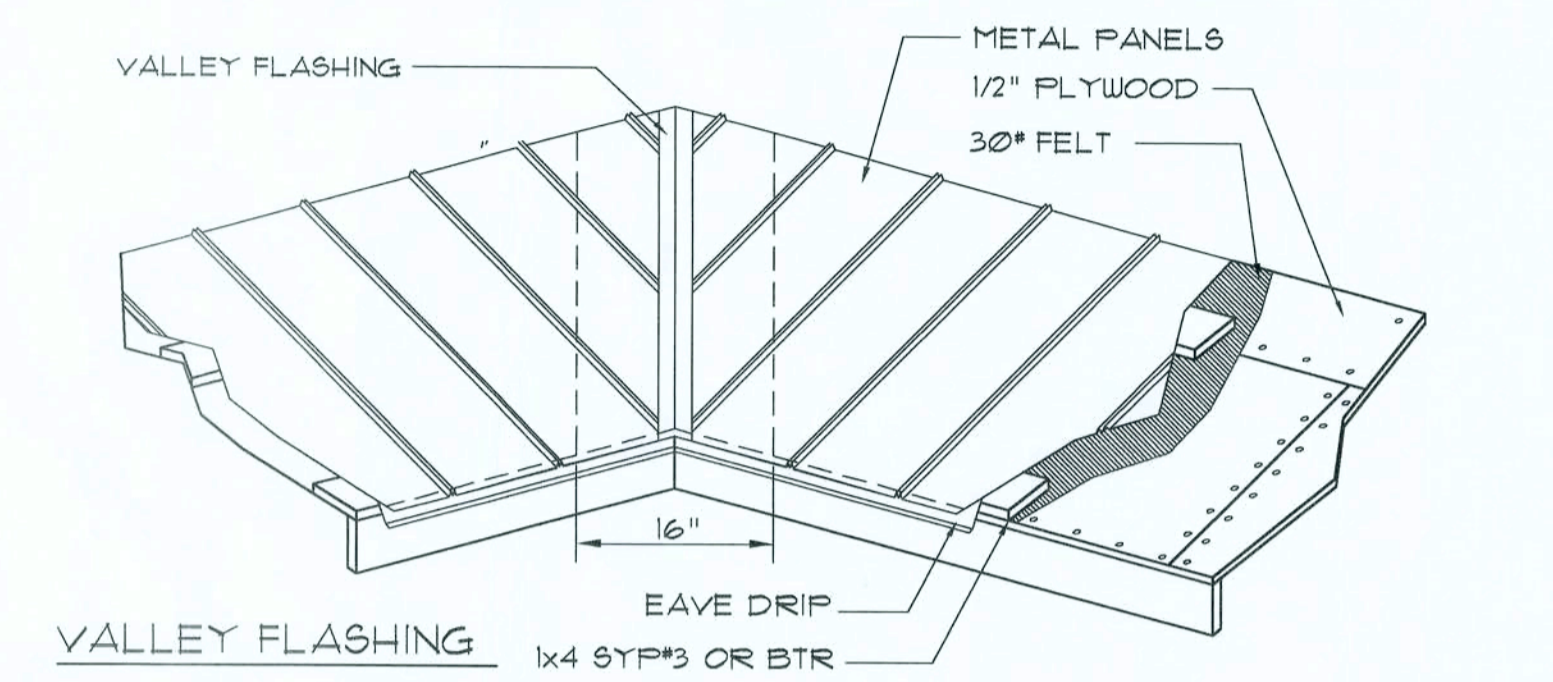

**5M-RIB PANEL INSTALLATION NOTES**

UNDERLAYMENT APPLICATION:  
FOR ROOF SLOPES FROM 3/12 TO 4/12, UNDERLAYMENT SHALL BE A MIN. OF TWO LAYERS APPLIED AS FOLLOWS:  
1. STARTING AT THE EAVE, A 19 INCH STRIP OF UNDERLAYMENT SHALL BE APPLIED PARALLEL WITH THE EAVE AND FASTENED SUFFICIENTLY TO STAY IN PLACE.  
2. STARTING AT THE EAVE, 36 INCH WIDE STRIPS OF UNDERLAYMENT FELT SHALL BE APPLIED OVERLAPPING SUCCESSIVE SHEETS 19 INCHES AND FASTENED SUFFICIENTLY TO STAY IN PLACE.

FOR ROOF SLOPED 4/12 AND GREATER, UNDERLAYMENT SHALL BE A MIN. OF ONE LAYER OF UNDERLAYMENT FELT APPLIED AS FOLLOWS:  
STARTING AT THE EAVE, UNDERLAYMENT SHALL BE APPLIED SHINGLE FASHION PARALLEL TO THE EAVE, LAPPED 2 INCHES, AND FASTENED SUFFICIENTLY TO STAY IN PLACE.  
OF ONE LAYER OF UNDERLAYMENT FELT APPLIED AS FOLLOWS:  
STARTING AT THE EAVE, UNDERLAYMENT SHALL BE APPLIED SHINGLE FASHION PARALLEL TO THE EAVE, LAPPED 2 INCHES, AND FASTENED SUFFICIENTLY TO STAY IN PLACE.

FOR ROOF SLOPED 4/12 AND GREATER, UNDERLAYMENT SHALL BE A MINIMUM OF ONE LAYER OF UNDERLAYMENT FELT APPLIED AS FOLLOWS:  
STARTING AT THE EAVE, UNDERLAYMENT SHALL BE APPLIED SHINGLE FASHION PARALLEL TO THE EAVE, LAPPED 2 INCHES, AND FASTENED SUFFICIENTLY TO STAY IN PLACE.

BASE AND CAP FLASHINGS:  
BASE AND CAP FLASHING SHALL BE INSTALLED IN ACCORDANCE W/ MFG'S INSTALLATION INSTRUCTIONS. BASE FLASHING SHALL BE EITHER CORROSION RESISTANT METAL OF MINIMUM NOMINAL THICKNESS 0.019 INCH OR MINERAL SURFACE ROLL ROOFING WEIGHING A MINIMUM OF 11 LBS PER 100 SQUARE FEET. CAP FLASHING SHALL BE CORROSION RESISTANT METAL OF MINIMUM NOMINAL THICKNESS OF 0.019 INCH.

VALLEYS:  
VALLEY LININGS SHALL BE INSTALLED IN ACCORDANCE W/ MANUFACTURER'S INSTALLATION INSTRUCTIONS BEFORE APPLYING ROOFING MATERIAL. VALLEY LININGS OF THE FOLLOWING TYPES SHALL BE PERMITTED:  
1. OPEN VALLEYS LINED WITH METAL: THE VALLEY LINING SHALL BE AT LEAST 16" WIDE AND OF ANY OF THE CORROSION RESISTANT METALS IN FBC TABLE 1502.3.2.  
2. OPEN VALLEYS: VALLEY LINING OF MINERAL SURFACE ROLL ROOFING SHALL BE PERMITTED. THE BOTTOM LAYER SHALL BE 18 INCHES AND THE TOP LAYER A MINIMUM OF 36 INCHES WIDE.  
3. CLOSED VALLEYS: VALLEY LINING SHALL BE ONE OF THE FOLLOWING:  
1. BOTH TYPES 1 AND 2 ABOVE, COMBINED.  
2. ONE PLY OF SMOOTH ROLL ROOFING AT LEAST 36 INCHES WIDE AND COMPLYING WITH ASTM D 224.  
3. SPECIALTY UNDERLAYMENT AT LEAST 36 INCHES WIDE 4 COMPLYING WITH ASTM D 1910.

DECK REQUIREMENTS:  
METAL PANELS MUST BE FASTENED TO MIN. 1/2" CDX PLYWOOD.

SLOPE:  
METAL PANELS SHALL BE USED ONLY ON ROOF SLOPES OF 3/12 OR GREATER.

CAULKING:  
MUST BE APPROVED BY THE MANUFACTURER, BUTYL SEALANT SUPPLIED IN TAPE OR GUN-GRADE FORM.

METAL PANEL:  
METAL PANELS SHALL BE MIN. 26 GAUGE AND COMPLY WITH ASTM A-192 AND D 7-98 EXPOSURE C.

FASTENERS:  
FASTENERS FOR METAL PANELS SHALL BE GALVANIZED WOOD FAST SCREW, MIN. OF #9 X 1 1/2" HEX HEAD.

BASE AND CAP FLASHINGS:  
BASE AND CAP FLASHING SHALL BE INSTALLED IN ACCORDANCE W/ MFG'S INSTALLATION INSTRUCTIONS.

REVISION:  
Copyright 2000  
N.E. Gilmer, Architect  
DRAWN:  
DJR

Custom Designed Home for:  
**DANIEL & MICHELLE STAGG**  
COLUMBIA COUNTY, FLORIDA  
OPT. METAL ROOF DETAILS

**ADD**  
ARCHITECTURAL DRAFTING & DESIGN, INC.  
LAKE CITY, FL 32055 - 386.622.4670

**NE**  
NICHOLS ARCHITECTS  
1758 NW Brown Rd.  
Lake City, FL 32055  
386-725-9022  
A.C.A. No. 1250  
A.R.C. No. 1250

DATE:  
20NOV2001  
COMM:

SHEET:  
A.12  
12 OF 15

AR0007005

REVISION:

Copyright 2005  
N.P. Keller, Architect

DRAWN:

DJR

Custom Designed Home for:  
**DANIEL & MICHELLE STAGG**  
COLUMBIA COUNTY, FLORIDA  
**ELECTRICAL PLAN**

**ADD**  
ARCHITECTURAL DRAFTING & DESIGN, INC.  
Lake City, FL 32056 - 386.524.670

**NE**  
NICHOLAS ASAR  
ON  
GEORGE  
ARCHITECT  
N.C.A.R.B. Certified  
1758 NW Broward Rd.  
386-753-902

DATE:

20NOV2007

COMM:

SHEET:

A.13

13 OF 15

AR0007005

### Electrical Computations

General Lighting/Receptacles @ 3w/sf  
29470 sf x 3w = 88410w  
Washer Circuit 15000w  
Dishwasher Circuit 15000w  
Sm. Appliance Circuits (3 @ 15000w) 45000w

Sub-Total 163410w  
1st 3kW @ 100% 30000w  
Bal. of kW @ 35% 46630w

Fixed Appliances:  
Refrigerator 12000w  
Cig. Fans (7 @ 200w) 14000w  
Irrigation Pump (future) 12000w  
Water Well Pump 12000w  
EWH 45000w  
Spares (8 @ 400w) 32000w

Sub-Total 127000w  
Load @ 15% D.F. 95250w

100% Demand Factor Loads:  
Dryer 50000w  
Range 80000w  
HVAC System (40T Heat Pump) 48000w  
Total Demand Load: 349940w

FEEDER SIZE: 349940w / 240v = 14581 amperes  
USE: 3 #2/0 THW w/ 1 # Cu GND / 2 1/2" C.

TYPICAL LOAD COMPUTATIONS:  
THE ABV. LOAD COMPUTATIONS ARE TYPICAL AND MAY NOT MATCH THE PROJECT LOADS. ELECTRICIAN SHALL PROVIDE LOAD CALCULATIONS BASED ON THE AS-BUILT CONNECTED LOADS & DEVICES.

### Panel Schedule

PANEL "L": 200A - MLO - 120/240V - 1" - 4 WIRE  
40 SLOT - FLUSH MOUNT

CIR. NO.	LOCATION	TRIP POLES	WIRE SIZE	LOAD
1-8	LIGHTING/RECEPT.	15A/1P	14NM	8841W
9	DISHWASHER	15A/1P	14NM	1500W
10-12	SM. KITCHEN AFFLIANCES	20A/1P	12NM	4500W
13-14	CEILING FANS	15A/1P	14NM	1400W
15,17	FUT. IRRIGATION PUMP	20A/1P	12NM	1200W
16	REFRIGERATOR	15A/1P	14NM	1200W
18	SPARE	-	-	400W
19,21	EWH	30A/2P	10NM	45000W
20,22	RANGE	50A/2P	6NM	8000W
23,25	WATER WELL	20A/2P	12NM	1200W
24,26	DRYER	30A/2P	10NM	5000W
27,29	HVAC CU	50A/2P	6NM	4800W
30,30	HVAC AHU	20A/2P	12NM	800W
31,33	FUT. FOOT PUMP	20A/2P	12NM	1200W
34	SPARE	-	-	400W
35-40	SPARE	-	-	2400W
TOTAL CONNECTED LOAD:				41341W

NOTE: TELEPHONE, TELEVISION AND OTHER LOW VOLTAGE DEVICES OR OUTLETS SHALL BE AS PER THE OWNER'S DIRECTIONS, AND IN ACCORDANCE W/ APPLICABLE SECTIONS OF NEC - LATEST EDITION.

TYPICAL PANEL SCHEDULE:  
ELECTRICIAN TO PROVIDE A FINAL PANEL SCHEDULE BASED ON THE AS-BUILT CONDITIONS & CONNECTED DEVICES.

TYPICAL LOAD COMPUTATIONS:  
ELECTRICIAN TO CALCULATE ACTUAL LOAD FROM AS-BUILT CONDITIONS & CONNECTED DEVICES.

### ELECTRICAL PLAN NOTES

- WIRE ALL APPLIANCES, HVAC UNITS AND OTHER EQUIPMENT PER MANUF. SPECIFICATIONS.
- CONSULT THE OWNER FOR THE NUMBER OF SEPERATE TELEPHONE LINES TO BE INSTALLED.
- INSTALLATION SHALL BE PER NAT'L. ELECTRIC CODE.
- NOTE: SMOKE DETECTORS SHALL BE MOUNTED NOT LESS THAN 30" ABOVE FINISHED FLOOR AND SHALL BE THE IONIZATION TYPE, INTERLOCKED TOGETHER, POWERED FROM HOUSE PANEL W/BATTERY BACKUP
- TELEPHONE, TELEVISION AND OTHER LOW VOLTAGE DEVICES OR OUTLETS SHALL BE AS PER THE OWNER'S DIRECTIONS, & IN ACCORDANCE W/ APPLICABLE SECTIONS OF NEC-LATEST EDITION.
- ELECTRICAL CONTR SHALL PREPARE "AS-BUILT" SHOP DWGS INDICATING ALL ELECTRICAL WORK, INCLUDING ANY CHANGES TO THE ELEC. PLAN, ADDNS TO THE ELEC. PLAN, RISER DIAGRAM, AS-BUILT PANEL SCHEDULE W/ ALL CKTS IDENTIFIED W/ CKT N., DESCRIPTION & BRKR. SERVICE ENT. & ALL UNDERGROUND WIRE LOCATIONS/ROUTING/DEPTH, RISER DIA. SHALL INCLUDE WIRE SIZES/TYPES & EQUIPMENT TYPE W/ RATINGS & LOADS. CONTRACTOR SHALL PROVIDE 1 COPY OF AS-BUILT DWGS TO OWNER & 1 COPY TO THE PERMIT ISSUING AUTHORITY.

NOTE: EXTERIOR FLOODLIGHTS TO BE SPECIFIED AND LOCATED BY OWNER AND INSTALLED PER MANUFACTURERS RECOMMENDATIONS

### Electrical SYMBOLS

- § SPST WALL SWITCH
- §§ DPDT WALL SWITCH (3-WAY)
- Ⓛ DUPLEX WALL RECEPTACLE
- Ⓛ DUPLEX WALL RECEPT., BELOW COUNTER
- Ⓛ 240V OUTLET
- Ⓛ GFI GND FAULT INTERRUPTER DUPLEX RECEPT.
- Ⓛ GFI WEATHER PROOF GFI DUPLEX RECEPT.
- Ⓛ ARC FAULT INTERRUPTER DUPLEX RECEPT.
- Ⓛ DUPLEX WALL RECEPTACLE, 1/2 SWITCHED
- Ⓛ MOTOR
- Ⓛ ELECTRICAL PANEL
- Ⓛ EXHAUST FAN / LIGHT
- Ⓛ DBL. LAMP INC. FLOOD LIGHT
- Ⓛ INC. LIGHT FIXTURE
- Ⓛ SMOKE DETECTOR, 120V
- Ⓛ 4 TUBE FLU. PRISMATIC WRAP SURFACE FIXTURE
- Ⓛ CHIME
- Ⓛ MOMENTARY PUSHBUTTON SWITCH, LIGHTED
- Ⓛ SWITCH/FIXTURE WIRING
- Ⓛ CONTROL WIRE - LOW VOLTAGE
- Ⓛ NON-FUSED DISC. SWITCH
- Ⓛ TELEPHONE
- Ⓛ TELEVISION OUTLET
- Ⓛ HVAC THERMOSTAT, @ 60" AFF
- Ⓛ CEILING FAN, W/ INC. LIGHT FIXTURE
- Ⓛ RECESSED LIGHT FIXTURE

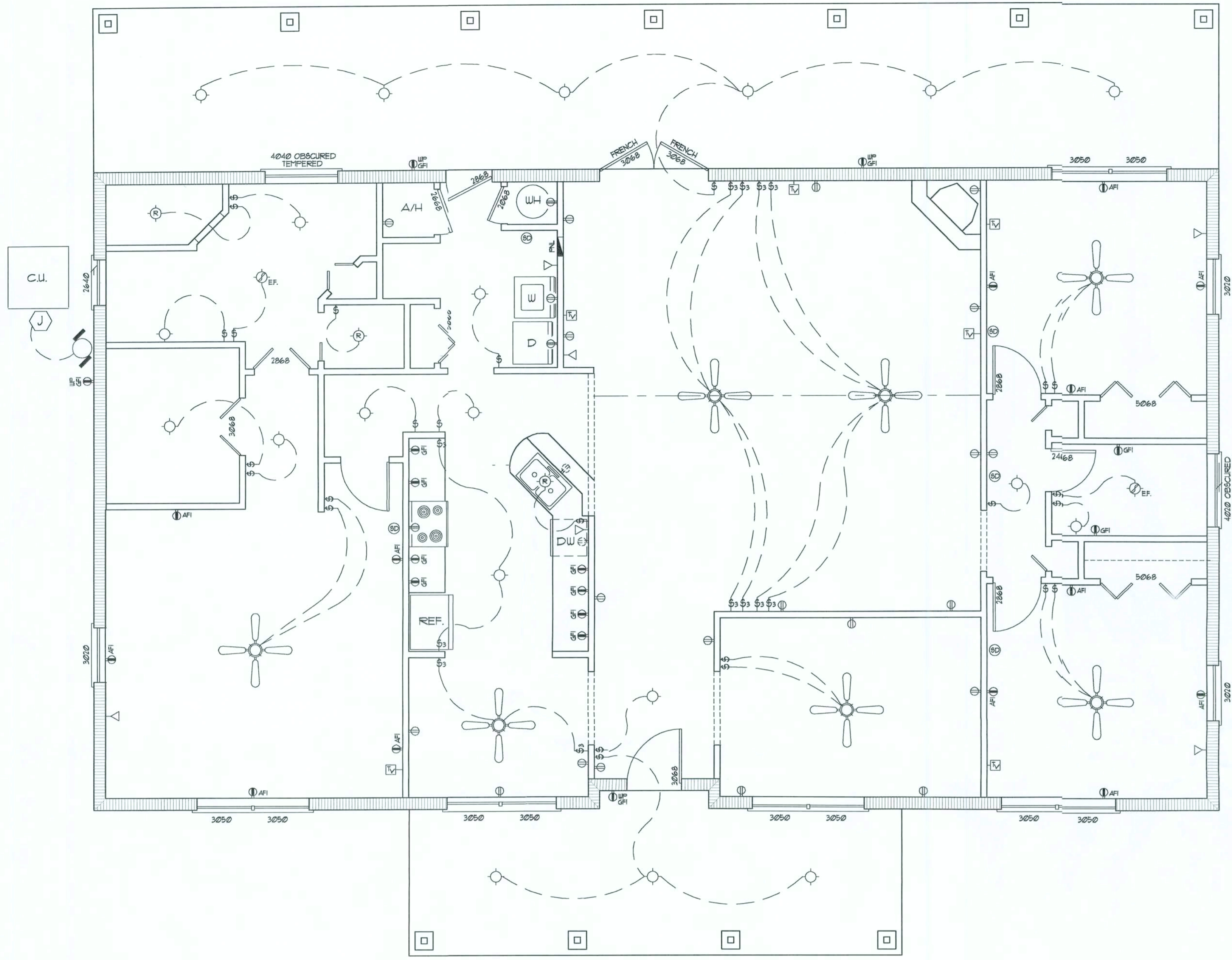

### Electrical PLAN

SCALE 1/4" = 1'-0"

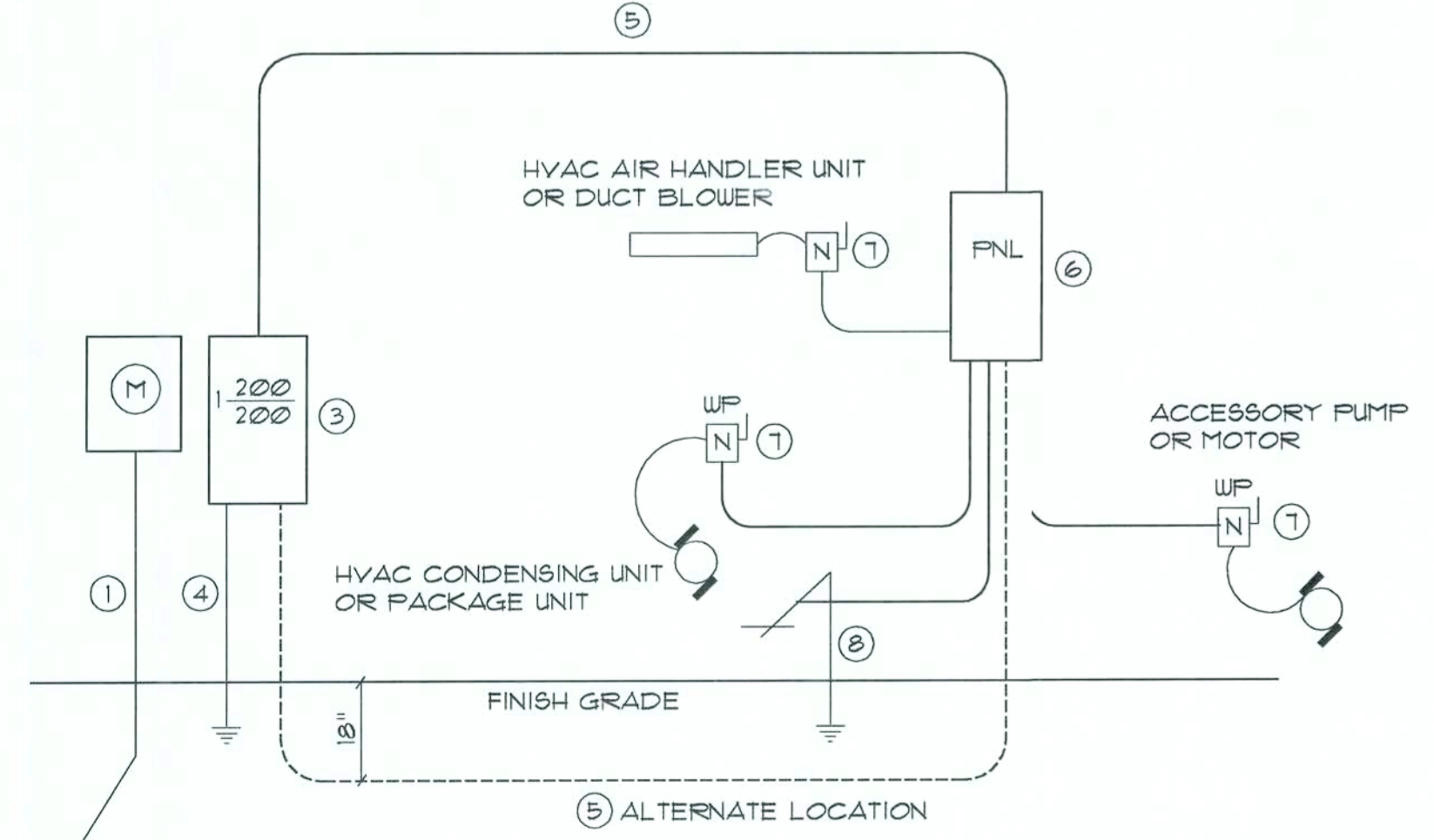

### Electrical Riser : 200A

SCALE: NONE

- SERVICE FEEDER ENTRANCE CONDUCTOR: 2 1/2" RIDGID CONDUIT, MIN. 18" DEEP, W/CONTINUOUS GROUND BONDING CONDUCTOR. SERVICE ENTRANCE CONDUCTORS SHALL NOT BE SPLICED EXCEPT THAT BOLTED CONNECTIONS AT THE METER DISCONNECTING DEVICES AND PANEL SHALL BE ALLOWED.
- METER ENCLOSURE, WEATHERPROOF, U.L. LISTED
- MAIN DISCONNECT SWITCH FUSED OR MAIN BRKR. WEATHERPROOF, U.L. LISTED.
- SERVICE ENTRANCE GROUND: 5/8" IRON/STEEL ROD X 8'-0" LONG AND/OR CONCRETE ENCASED FOUNDATION STEEL REBAR X 2'-0" LONG. GROUNDING CONDUCTOR SHALL BOND TO EACH PIECE OF SERVICE/ENTRANCE EQUIPMENT, AND SHALL BE SIZED PER ITEM 15 BELOW.
- 200 AMPERE SERVICE: 3-#2/0 - USE - CU, 1-#4 - CU GND, 2" CONDUIT.
- HOUSE PANEL (PNL). U.L. LISTED, SIZED PER SCHEDULE.
- EQUIPMENT DISCONNECT SWITCH: NON-FUSED, IN WEATHERPROOF ENCLOSURE, SIZE ACCORDING TO PANEL SCHEDULE LOADS.
- PROVIDE GROUND BOND WIRE TO METAL PIPING, SIZE IN ACCORDANCE WITH THE SERVICE GROUND CONDUCTOR.

NOTE: THE MINIMUM AIC RATING FOR PANEL BOARDS, BRKRS. AND DISCONNECT SWITCHES SHALL BE 22,000 AIC.

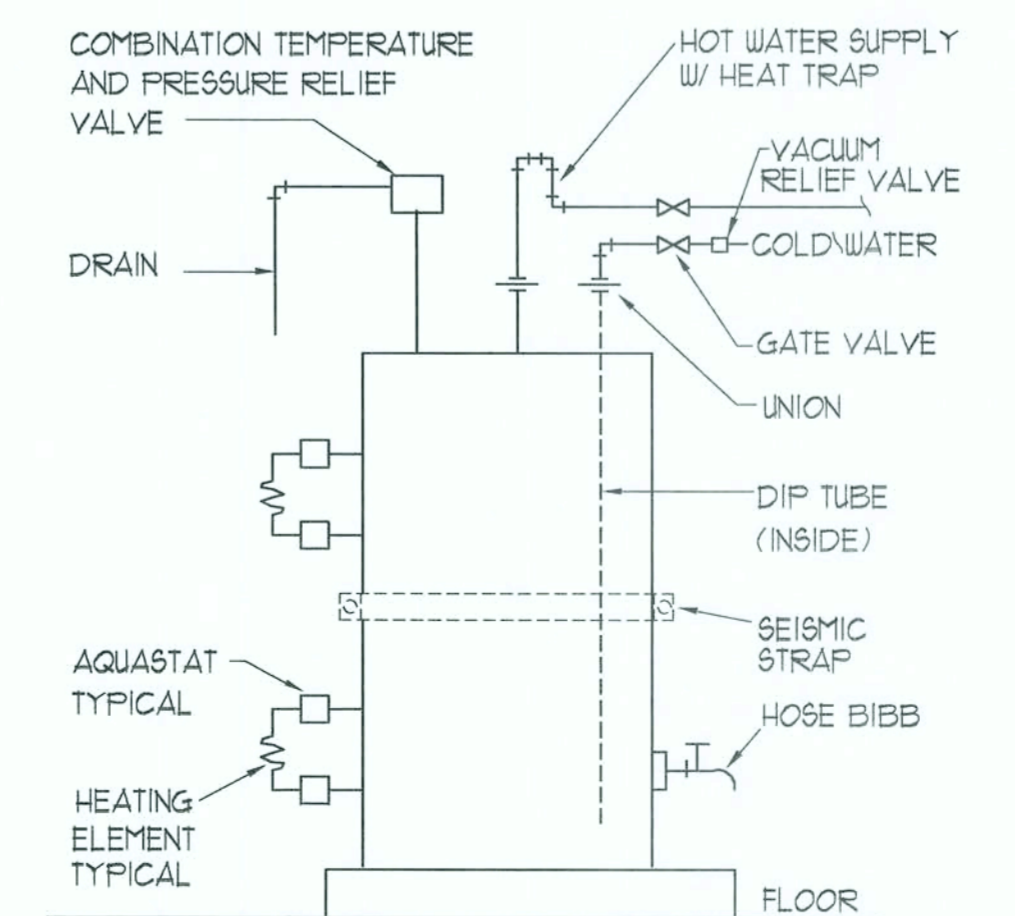

### Elec. Water Heater

SCALE: NONE

PROJECT INFORMATION / NOTES:

DESIGN VALUES/LOADS & CODES

WIND DESIGN SPEED: 110 MPH, UNLESS NOTED OTHERWISE

SOIL DESIGN STATEMENT: FOOTING DESIGN IS BASED UPON 1000PSF SOIL BEARING PRESSURE PROVIDED BY CLEAN SAND, GRAVEL OR STONE. OTHER SOIL CONDITIONS, i.e. CLAY, HIGH LEVEL OF ORGANICS OR OTHER UNDESIRABLE SOILS SHALL REQUIRE FOUNDATION MODIFICATIONS.

LIVE LOADS: 1st FLOOR: 40PSF, 2nd FLOOR: 30PSF, ROOF: AS DETERMINED BY SHAPE FACTORS APPLIED TO THE WIND FORCE GENERATED BY THE DESIGN WIND SPEED.

BUILDING CODE: SOUTHERN STANDARD BUILDING CODE CONGRESS INTERNATIONAL - LATEST ELECTRICAL CODE: NATIONAL ELECTRICAL CODE - LATEST LIFE SAFETY: NFPA-101 - LATEST

CONSTRUCTION DOCUMENTS

THE CUSTOMER IS RESPONSIBLE FOR DELIVERING THE REQUIRED SETS OF CONSTRUCTION DOCUMENTS TO THE PERMIT ISSUING AUTHORITIES FOR THE ISSUANCE OF CONSTRUCTION PERMITS. THE CONTRACTOR SHALL REVIEW THE CONSTRUCTION DOCUMENTS AND VERIFY ALL DIMENSIONS, ANY DISCREPANCIES SHALL BE REPORTED TO THE ARCHITECT PRIOR TO THE COMMENCEMENT OF ANY WORK OR FABRICATION OF ANY MATERIALS.

DO NOT SCALE OFF THESE PLANS

AMPLE DIMENSIONS ARE SHOWN ON THE PLANS TO LOCATE ALL ITEMS. SIMPLE ARITHMETIC MAY BE USED TO DETERMINE THE LOCATIONS OF THOSE ITEMS NOT DIMENSIONED.

CHANGES TO FINAL PLAN SETS

PLEASE DO NOT MAKE ANY STRUCTURAL CHANGES TO THESE PLANS WITHOUT CONSULTING WITH THE ARCHITECT. THE OWNER SHALL ASSUME ANY AND ALL LIABILITY FOR STRUCTURAL DAMAGE RESULTING FROM CHANGES MADE TO THE PLANS OR BY SUBSTITUTION OF MATERIALS DIFFERENT FROM SPECIFICATION ON THE PLANS.

INORGANIC ARSENICAL PRESSURE TREATED WOOD

SOME FRAMING MATERIALS SPECIFIED FOR THE CONSTRUCTION OF YOUR PROJECT SUCH AS SILL OR EXTERIOR FRAMING ARE PRESSURE TREATED. EACH PIECE IS CLEARLY MARKED FOR EASY IDENTIFICATION AND IS USUALLY GREENISH IN COLOR.

THIS WOOD HAS BEEN PRESERVED BY PRESSURE-TREATMENT WITH AN EPA-REGISTERED PESTICIDE CONTAINING INORGANIC ARSENIC TO PROTECT IT FROM INSECT ATTACK AND DECAY. EXPOSURE TO TREATED WOOD MAY PRESENT CERTAIN HAZARDS, THEREFORE, PRECAUTIONS SHOULD BE TAKEN BOTH WHEN HANDLING THE TREATED WOOD AND IN DETERMINING WHERE TO USE OR DISPOSE OF THE TREATED WOOD.

FOR FURTHER INFORMATION ON THE USE OF AND DISPOSAL OF INORGANIC ARSENIC PRESSURE TREATED WOOD, PLEASE REFER TO THE EPA MATERIAL SAFETY SHEET DEALING WITH THIS PRODUCT.

GENERAL H.V.A.C. NOTES:

- 1. SUB-CONTRACTORS PROVIDING HVAC INSTALLATION SHALL BE SUBJECT TO THE PROVISIONS OF NOTES 1 THRU 6, GENERAL NOTES/D.16.
2. HVAC SUB-CONTRACTOR SHALL PROVIDE ALL LABOR, MATERIALS, TOOLS AND EQUIPMENT TO INSTALL A COMPLETE & OPERATING HVAC SYSTEM.
3. HVAC SYSTEM SHALL BE AS DETAILED IN THE PLANS (IF INCLUDED), OR SHALL BE AS DIRECTED BY THE OWNER IN CONSULTATION WITH THE HVAC SUB-CONTRACTOR.
4. HVAC SUB-CONTRACTOR SHALL FURNISH SHOP DRUGS FOR DUCTWORK, CONDENSING UNIT & AIR HANDLER, EXHAUST FANS AND AIR DEVICES.
5. IT IS THE HVAC SUB-CONTRACTOR'S RESPONSIBILITY TO COMPLY WITH NFPA-90A AND ALL APPLICABLE CODES.
6. FLEXIBLE DUCT SHALL BE FULLY ANNEALED, CORRUGATED ALUMINUM W/ 3/4 LB. DENSITY FIBERGLASS INSULATION AND SHALL BE UL LISTED. SHEET METAL DUCT SHALL BE LINED W/ 1" MATFACED DUCT LINER & WRAPPED W/ 3/4 LB. FOILFACED FIBERGLASS INSULATION. ALL FIBERGLASS DUCT SHALL BE FOILFACED, R42/R6 @ DUCTBOARD.
7. ALL EXHAUST AND OUTSIDE AIR DUCT SHALL BE GALVANIZED SHEET METAL CONSTRUCTED AND INSTALLED IN ACCORDANCE WITH ASHREA AND SHACNA STANDARDS.
8. ALL AIR DEVICES SHALL BE OF ALUMINUM CONSTRUCTION FOR WALL AND CEILING APPLICATIONS AND STEEL CONSTRUCTION IN FLOOR APPLICATIONS. ACCEPTABLE MANUFACTURER'S SHALL BE TITUS, METALAIR, NAILORHART, HART & COOLIE OR AS DIRECTED BY THE OWNER.
9. IF REQUIRED BY THE OWNER, THE HVAC SUB-CONTRACTOR SHALL SUPPLY A TEST AND BALANCE REPORT IN ACCORDANCE WITH AIR BALANCE COUNCIL STANDARDS, SIGN AND SEALED BY A REGISTERED ENGINEER.
10. HVAC SUB-CONTRACTOR SHALL SUPPLY ALL CONTRACTORS, RELAYS, AND THERMOSTATS. THE ELECTRICAL SUB-CONTRACTOR SHALL PROVIDE ALL SWITCHES, DISCONNECTS & CONTROL WIRING. THERMOSTATS SHALL BE APPROVED BY THE EQUIPMENT MFG'R.
11. ALL DUCT SIZES INDICATED IN THE PLANS (IF INCLUDED) ARE NET INSIDE DIMENSIONS.
12. ALL EQUIPMENT SHALL BE FULLY WARRANTED FOR 1 YEAR AND THE COMPRESSOR(S) SHALL BE WARRANTED 5 YEARS FROM DATE OF FINAL ACCEPTANCE, BY THE OWNER.
13. ALL WORK IN THIS TRADE SHALL BE COORDINATED WITH ALL OTHER TRADES SO AS TO AVOID CONFLICTS OR HINDERANCE TO COMPLETION OF THE JOB.
14. CONDENSATE DRAIN PIPING SHALL BE INSULATED WITH 1/2" THICK ARMAFLEX INSULATION.
15. FILTERS SHALL BE DISPOSABLE TYPE AND HAVE INITIAL SHARE WEIGHT RESISTANCE OF 10% AND A CLEAN PRESSURE DROP OF 0.15. PROVIDE 2 SETS, ONE DURING CONSTRUCTION AND ONE FOR USE AT FINAL ACCEPTANCE.
16. HVAC SUB-CONTRACTOR SHALL PROVIDE & INSTALL ALL NECESSARY OFFSETS, TRANSITIONS & BENDS REQUIRED TO PROVIDE A COMPLETE SYSTEM AT NO ADDITIONAL COST TO THE OWNER.
17. IT IS THE RESPONSIBILITY OF THE HVAC SUB-CONTRACTOR TO COORDINATE LOCATION OF CEILING DIFFUSERS, GRILLES AND REGISTERS IN THE FIELD WITH THE ELECTRICIAN, LIGHTS AND ARCHITECTURAL ELEMENTS.
18. COORDINATE W/ THE ELECTRICIAN, PARTICULARLY ELECTRICAL NOTE N. 23, TO ASSURE SUITABLE SIZES OF BREAKERS, SWITCHES AND WIRING.

GENERAL NOTES:

- 1. THE CONTRACTOR SHALL INDEMNIFY THE OWNER AGAINST ALL CLAIMS, WHETHER FROM PERSONAL INJURY OR PROPERTY DAMAGE, ARISING FROM EVENTS ASSOCIATED WITH THE WORK PERFORMED UNDER THE CONTRACT FOR THIS PROJECT.
2. THE CONTRACTOR AND/OR SUB-CONTRACTORS SHALL WARRANT ALL WORK FOR A PERIOD OF ONE YEAR FOLLOWING THE DATE OF FINAL COMPLETION AND ACCEPTANCE BY THE OWNER. DEFECTS IN MATERIALS, EQUIPMENT, COMPONENTS AND WORKMANSHIP SHALL BE CORRECTED AT NO FURTHER COST TO THE OWNER DURING THE ONE YEAR WARRANTY PERIOD.
3. AT THE OWNER'S OPTION, A WARRANTY INSPECTION SHALL BE PERFORMED DURING THE ELEVENTH MONTH FOLLOWING THE COMMENCEMENT OF THE WARRANTY PERIOD. FOR THE PURPOSE OF DETERMINING ANY WARRANTY CLAIM THAT MAY BE REQUIRED, THE CONTRACTOR SHALL BE PRESENT DURING THIS INSPECTION IF REQUESTED BY THE OWNER.
4. THE CONTRACTOR SHALL PAY FOR ALL PERMITS, LICENSES, TESTS AND THE LIKE THAT MAY BE REQUIRED BY THE VARIOUS AUTHORITIES HAVING JURISDICTION OVER THIS PROJECT BE THEY CITY, COUNTY, STATE OR FEDERAL.
5. THE OWNER SHALL FILE A "NOTICE OF COMMENCEMENT" PRIOR TO THE BEGINNING OF THE PROJECT AND THE CONTRACTOR(S) SHALL FILE "NOTICE TO OWNER" AND PROVIDE "RELEASE OF LIEN" FOR ALL PAYMENT REQUESTS PRIOR TO DISBURSEMENT OF ANY FUNDS.
6. ANY AND ALL DISPUTES ARISING FROM EVENTS ASSOCIATED WITH THE CONSTRUCTION OF THIS PROJECT BETWEEN THE OWNER, CONTRACTOR(S) AND SUPPLIERS SHALL BE RESOLVED THROUGH BINDING ARBITRATION.
7. ALL WORK SHALL BE IN ACCORDANCE W/ APPLICABLE CODES AND LOCAL REGULATIONS, INCLUDING APPLICABLE ENERGY CODES. ALL COMPONENTS OF THE BUILDING SHALL MEET WITH THE MINIMUM ENERGY REQUIREMENTS OF THE BUILDING CODE. ANY DISCREPANCIES SHALL BE REPORTED TO THE ARCHITECT IN WRITING PRIOR TO THE COMMENCEMENT OF THE WORK.
8. ALL INSULATION SHALL BE LEFT EXPOSED AND ALL LABELS LEFT INTACT ON THE WINDOWS AND DOORS UNTIL INSPECTED BY THE BUILDING OFFICIAL.
9. ALL WOOD IN CONTACT WITH CONCRETE OR MASONRY SHALL BE PRESSURE TREATED.
10. INTERIOR BEARING WALLS SHALL BE CONSTRUCTED IN COMPLIANCE WITH "UL Design U333", BATT INSULATION SHALL BE INCLUDED WHERE UNCONDITIONED AREA IS BEING SEPARATED FROM HEATED / COOLED AREA.
11. INTERIOR STUD WALLS SEPARATING LIVING AREA FROM GARAGE AREAS SHALL BE CONSTRUCTED IN COMPLIANCE WITH "UL Design U333", INCLUDING R-11 BATT INSULATION.
12. CEILING OVER ATTACHED GARAGES OR GARAGES W/ LIVING AREA ABOVE SHALL BE 5/8" FIRECODE "C" GIB ON 1x3 WOOD FURRING AT 16" O.C., ATTACHED W/ 1 1/4" BUGLEHEAD SCREWS @ 6" O.C. ALONG EACH POINT OF BEARING.

GENERAL WELL & SEPTIC NOTES:

- 1. SUB-CONTRACTORS PROVIDING WATER WELLS AND/OR SEPTIC TANKS AND DRAINFIELDS SHALL BE SUBJECT TO THE PROVISIONS OF NOTES 1 THRU 6, THIS SHEET
2. LOCATION OF POTABLE WATER WELLS SHALL BE DETERMINED BY THE OWNER IN CONSULTATION WITH THE WELL DRILLING CONTRACTOR. WELLS SHALL NOT BE LOCATED CLOSER THAN 15'-0" TO ANY PROPOSED OR EXISTING SEPTIC TANK OR DRAINFIELD, EITHER ON SUBJECT PROPERTY OR ADJACENT/ADJOINING PROPERTY.
3. POTABLE WATER WELLS SHALL BE A MINIMUM 4" WITH BLACK IRON CASING TO A DEPTH OF 80'-0". PIPES SHALL BE OF THE SUBMERSIBLE TYPE, THREE WIRE SYSTEM, MINIMUM HORSEPOWER SHALL BE 1/2 HP OR AS DIRECTED BY THE OWNER. MOTOR STARTER SHALL BE ENCLOSED IN A WEATHERPROOF HOUSING, MOUNTED ON A P/T 4X4 POST AT THE WELL HEAD.
4. WELL HEAD SHALL PROJECT 12" ABOVE GRADE.
5. ALL REQUIRED COMPONENTS FOR A COMPLETE OPERATING SYSTEM SHALL BE PROVIDED, INCLUDING ANTI-FREEZE BLEEDER FITTING, CHECKVALVE, AIR BLEEDERS, SHUTOFF VALVE, HOSE BIBB, PRESSURE REGULATOR/CONTROLLER, UNIONS AND PRESSURE GAUGE.
6. PRESSURE TANK SHALL BE GALVANIZED 82 GALLON CAPACITY, UNLESS DIRECTED OTHERWISE BY THE OWNER.
7. SEPTIC TANK LOCATION & DRAINFIELD INVERT SHALL BE DETERMINED BY THE LOCAL HEALTH DEPARTMENT, IN CONSULTATION W/ THE OWNER.
8. SEPTIC TANKS SHALL BE OF A SIZE & CONSTRUCTION AS DETERMINED BY THE LOCAL HEALTH DEPARTMENT. TANK MAT'L SHALL BE Poured CONCRETE OR FIBERGLASS AS ALLOWED BY THE SEPTIC TANK PERMIT.
9. SEPTIC DRAINFIELDS SHALL BE CONSTRUCTED TO THE STANDARDS OF THE LOCAL HEALTH DEPARTMENT. DRAINFIELD PIPING SHALL BE CLAY TILE OR P.V.C. OR POLY AS ALLOWED BY THE SEPTIC TANK PERMIT. DRAINFIELD BEDS SHALL BE 3/4" WASHED ROCK, INSTALLED THICKNESS SHALL BE AS PER SEPTIC TANK PERMIT.
10. SAND FILTER BEDS, MOUND SYSTEMS, DOSING TANKS, GREASE TRAPS, DISTRIBUTION BOXES, GRINDER PUMPS, SUMP PUMPS AND OTHER SUCH RELATED ITEMS (IF REQUESTED OR REQUIRED) SHALL BE AS PER THE DESIGN STANDARDS OF THE LOCAL HEALTH DEPARTMENT.

GENERAL MILLWORK NOTES:

- 1. MILLWORK SUB-CONTRACTOR PROVIDING CASEWORK, MILLWORK OR THE LIKE FOR THIS PROJECT SHALL BE SUBJECT TO THE PROVISIONS OF NOTES 1 THRU 6 OF THE GENERAL NOTES, THIS SHEET.
2. SCOPE OF WORK INCLUDES, BUT IS NOT LIMITED TO THE FOLLOWING: FABRICATION AND DELIVERY OF MILLWORK, SHOWN IN THE DRAWINGS, TO THE JOB SITE, INSTALLATION OF CABINET HINGES, CATCHES, DRAWER & TRAY GUIDES, ADJUSTABLE SHELF STANDARDS & SURFACE BOLTS.
3. ALL APPLICABLE STANDARDS OF "AW" QUALITY STANDARDS & GUIDE SPECIFICATIONS APPLY TO THIS PROJECT, UNLESS NOTED OTHERWISE.
4. ALL "CUSTOM" GRADES EXCEPT AS OTHERWISE NOTED OR DIRECTED BY THE OWNER, SHALL BE THE BASE STANDARD OF QUALITY REQ'D FOR THIS WORK.
5. MILLWORK SUB-CONTRACTOR SHALL SUBMIT FOR APPROVAL BY THE OWNER, THE FOLLOWING ITEMS, PRIOR TO FABRICATING ANY MAT'L'S OR MILLWORK: COMPLETE SET OF SHOP DRAWINGS, SAMPLES OF W.D. SPECIES RECEIVING TRANSPARENT FINISH, MFR'S LITERATURE FOR ALL SPECIALTY ITEMS NOT MFD. BY THE ARCHITECTURAL WOODWORK FIRM, AND HARDWARE SCHEDULE, SHOWING HARDWARE USED AT E.A. LOCATION & CONFORMANCE W/ THE DESIGN INTENT OF THE DRAWINGS OR DIRECTIVES ISSUED BY THE OWNER.
6. PRODUCTS SHALL INCLUDE THE FOLLOWING:
SOFTWOOD - SOLID STOCK PINE, C OR BETTER
HARDWOOD - SPECIES AS SELECTED BY OWNER
PLYWOOD, OPAQUE FINISH - FIR, GRADE A/B
PLYWOOD, TRANSPARENT FINISH - SPECIES AS SELECTED BY OWNER
PARTICLE BOARD - HIGH DENSITY, W/ RESIN BINDER
L.A.M. PLASTIC - MFG, COLORS, PATTERNS & TEXTURES AS SELECTED BY OWNER
LAMINATING ADHESIVES - POLYVINYL ACETATE, UREA-FORMALDEHYDE, CASEIN
7. ASSEMBLE WORK AT MILL & DELIVER TO JOB SITE READY TO INSTALL INsofar AS POSSIBLE.
8. PROTECT MILLWORK FROM MOISTURE & DAMAGE WHILE IN TRANSIT TO THE JOB SITE. UNLOAD AND STORE IN A PLACE WHERE IT WILL BE PROTECTED FROM MOISTURE AND DAMAGE AND BE CONVENIENT FOR INSTALLATION.
9. FABRICATE WORK IN ACCORDANCE WITH MEASUREMENTS TAKEN AT THE JOB SITE.
10. INSTALL HARDWARE IN ACCORDANCE WITH MANUF'R'S DIRECTIONS. LEAVE OPERATING HARDWARE OPERATING SMOOTHLY & QUIETLY.
11. DAMAGED SURFACES SHALL BE REPAIRED TO MATCH UNDAMAGED ADJACENT PORTION OF THE WORK.

TERMITE PROTECTION NOTES:

SOIL CHEMICAL BARRIER METHOD:

- 1. A PERMANENT SIGN WHICH IDENTIFIES THE TERMITE TREATMENT PROVIDER AND NEED FOR REINSPECTION AND TREATMENT CONTRACT RENEWAL SHALL BE PROVIDED. THE SIGN SHALL BE POSTED NEAR THE WATER HEATER OR ELECTRIC PANEL. FBC 1909.4.4
2. CONDENSATE AND ROOF DOWNSPOUTS SHALL DISCHARGE AT LEAST 1'-0" AWAY FROM BUILDING SIDE WALLS. FBC 1909.4.4
3. IRRIGATION/SPRINKLER SYSTEMS INCLUDING ALL RISERS AND SPRAY HEADS SHALL NOT BE INSTALLED WITHIN 1'-0" FROM BUILDING SIDE WALLS. FBC 1909.4.4
4. TO PROVIDE FOR INSPECTION FOR TERMITE INFESTATION, BETWEEN WALL COVERINGS AND FINAL EARTH GRADE SHALL NOT BE LESS THAN 6". EXCEPTION: PAINT AND DECORATIVE CEMENTIOUS FINISH LESS THAN 5/8" THICK ADHERED DIRECTLY TO THE FOUNDATION WALL. FBC 1409.1.6
5. INITIAL TREATMENT SHALL BE DONE AFTER ALL EXCAVATION AND BACKFILL IS COMPLETE. FBC 1916.11
6. SOIL DISTURBED AFTER THE INITIAL TREATMENT SHALL BE RETREATED INCLUDING SPACES BOXED OR FORMED. FBC 1916.12
7. BOXED AREAS IN CONCRETE FLOOR FOR SUBSEQUENT INSTALLATION OF TRAPS, ETC. SHALL BE MADE WITH PERMANENT METAL OR PLASTIC FORMS. PERMANENT FORMS MUST BE OF A SIZE AND DEPTH THAT WILL ELIMINATE THE DISTURBANCE OF SOIL AFTER THE INITIAL TREATMENT. FBC 1916.13
8. MINIMUM 6 MIL VAPOR RETARDER MUST BE INSTALLED TO PROTECT AGAINST RAINFALL DILUTION IF RAINFALL OCCURS BEFORE VAPOR RETARDER REPLACEMENT, RETREATMENT IS REQUIRED. FBC 1916.14
9. CONCRETE OVERPOUR AND MORTAR ALONG THE FOUNDATION PERIMETER MUST BE REMOVED BEFORE EXTERIOR SOIL TREATMENT. FBC 1916.15
10. SOIL TREATMENT MUST BE APPLIED UNDER ALL EXTERIOR CONCRETE OR GRADE WITHIN 1'-0" OF THE STRUCTURE SIDEWALLS. FBC 1916.16
11. AN EXTERIOR VERTICAL CHEMICAL BARRIER MUST BE INSTALLED AFTER CONSTRUCTION IS COMPLETE INCLUDING LANDSCAPING AND IRRIGATION. ANY SOIL DISTURBED AFTER THE VERTICAL BARRIER IS APPLIED, SHALL BE RETREATED. FBC 1916.16
12. ALL BUILDINGS ARE REQUIRED TO HAVE PER-CONSTRUCTION TREATMENT. FBC 1916.17
13. A CERTIFICATE OF COMPLIANCE MUST BE ISSUED TO THE BUILDING DEPARTMENT BY: \* LICENSED PEST CONTROL COMPANY BEFORE A CERTIFICATE OF OCCUPANCY WILL BE ISSUED. THE CERTIFICATE OF COMPLIANCE SHALL STATE: THE BUILDING HAS RECEIVED A COMPLETE TREATMENT FOR THE PREVENTION OF SUBTERRANEAN TERMITES. THE TREATMENT IS IN ACCORDANCE WITH THE UNDER SERVICES. FBC 1916.17
14. AFTER ALL WORK IS COMPLETED, LOOSE WOOD AND FILL MUST BE REMOVED FROM BELOW AND WITHIN 1'-0" OF THE BUILDING. THIS INCLUDES ALL GRADE STACKS, TUB TRAP BOXES, FORMS, SHORING OR OTHER CELLULOSE CONTAINING MATERIAL. FBC 1309.1.3
15. NO WOOD, VEGETATION, STUMPS, CARDBOARD, TRASH, ETC. SHALL BE BURIED WITHIN 15'-0" OF ANY BUILDING OR PROPOSED BUILDING. FBC 1309.1.4

GENERAL PLUMBING NOTES:

- 1. SUB-CONTRACTORS PROVIDING PLUMBING MATERIALS AND INSTALLATION SHALL BE SUBJECT TO THE PROVISIONS OF NOTES 1 THRU 6.
2. ALL WORKMANSHIP AND MATERIALS SHALL BE IN STRICT ACCORDANCE WITH APPLICABLE LOCAL CODES, RULES AND ORDINANCES.
3. ALL MATERIALS SHALL BE NEW.
4. ALL WORK SHALL BE PERFORMED BY A LICENSED PLUMBING CONTRACTOR IN A FIRST CLASS WORKMANLIKE MANNER. THE COMPLETED SYSTEM SHALL BE FULLY OPERATIONAL.
5. ALL EXCAVATION & BACKFILL AS REQUIRED FOR THIS PHASE OF THE CONSTRUCTION SHALL BE PART OF THE PLUMBING SUB-CONTRACTOR'S RESPONSIBILITIES.
6. PLUMBING FLAT PLANS AND RISER DIAGRAMS (IF INCLUDED) ARE DIAGRAMATIC. DO NOT SCALE THE DRAWINGS FOR EXACT LOCATIONS OF THE PLUMBING FIXTURES.
7. ALL WORK SHALL BE COORDINATED WITH OTHER TRADES TO AVOID INTERFERENCE WITH THE PROGRESS OF THE CONSTRUCTION.
8. WATER PIPING SHALL BE TYPE L COPPER UP TO 1", & TYPE K FOR ALL LARGER SIZES. ALL UNDERGROUND PIPING SHALL BE TYPE K COPPER. AT THE OWNER'S OPTION SUPPLY PIPING MAY BE C.P.V.C. SCHEDULE 40 OR SCHEDULE 80.
9. DO NOT USE LEAD BASED SOLDER FOR JOINING SUPPLY PIPING.
10. SOIL, WASTE, VENT & RAINWATER PIPING SHALL BE CAST IRON NO-HUB 30"-12" ABOVE GRADE WITH NEOPRENE GASKETS AND STAINLESS STEEL BANDS & BELL & SPIGOT CAST IRON BELOW GRADE W/ LEAD & OAKUM JOINTS OR AT THE OWNER'S OPTION, P.V.C., SCHEDULE 40. SEE NOTE 12.
11. AIR CONDITIONING CONDENSATE DRAIN PIPING SHALL BE THREADED STEEL PIPE, COPPER DRAIN, WASTE OR VENT PIPE AND FITTINGS, OR P.V.C. SEE NOTE 12. BELOW INSULATE ALL CONDENSATE PIPING EXCEPT WHERE UNDERGROUND, AND ELECTRIC HEAT WRAP WHERE EXPOSED TO FREEZING CONDITIONS.
12. P.V.C. SCHEDULE 40 PIPE AND FITTINGS MAY BE USED FOR SOIL, WASTE, VENT, RAINWATER OR CONDENSATE PIPING AS APPROPRIATE, WHERE APPROVED BY LOCAL BUILDING CODES & OFFICIALS. P.V.C. MAY NOT BE USED TO PENETRATE CHASES OR FIRE RATED WALLS / CEILING.
13. ALL FIXTURES MUST BE PROVIDED WITH READILY ACCESSIBLE STOPS AND WHERE PROVIDED, MARKED ACCESS PANELS.
14. FURNISH AND INSTALL APPROVED AIR CHAMBERS AT EACH PLUMBING FIXTURE AND APPROVED SHOCK ARRESTERS ON MAIN LINE OR RISERS.
15. DIELECTRIC COUPLINGS ARE REQUIRED BETWEEN ALL DISSIMILAR METALS IN PIPING AND EQUIPMENT CONNECTIONS.
16. ISOLATE COPPER PIPING FROM HANGERS OR SUPPORTS W/ HAIR FELT INSULATOR PADS.
17. PROVIDE 1/2" TRAP PRIMER LINE FOR ALL FLOOR DRAINS FROM NEAREST PLUMBING FIXTURE, DO NOT MANIFOLD.
18. PROVIDE ACCESS PANELS FOR ALL CONCEALED VALVES.
19. PROVIDE COMBINATION COVERPLATE / CLEANOUT PLUG FOR ALL WALL CLEANOUTS, FINISH AS DIRECTED BY THE OWNER.
20. FIXTURES, HARDWARE, EQUIPMENT, COLORS AND FINISHES SHALL BE AS SELECTED BY THE OWNER.

ELECTRICAL NOTES: General

- 1. DO NOT SCALE THE ELECTRICAL DRAWINGS. REFER TO ARCHITECTURAL PLANS AND ELEVATIONS FOR EXACT LOCATION OF ALL EQUIPMENT. CONFIRM WITH OWNER.
2. INSTALL ALL ELECTRICAL WORK IN CONFORMANCE WITH THE NEC LATEST EDITION, AND ITS AMENDMENTS AS ADOPTED BY THE PERMIT ISSUING AUTHORITY AT THE TIME OF CONSTRUCTION.
3. GROUNDING: GROUND ALL MAIN DISCONNECTS TO STANDARD GROUND ROD(S) AND TO COLD WATER SUPPLY AS PER ARTICLE 250 OF NEC-LATEST EDITION.
4. INSTALL ONLY COPPER WIRING ON THIS PROJECT. THW, THH, THHN, THHN OR NM CABLE, UNLESS NOTED OTHERWISE. ALL CONDUCTORS #10 & SMALLER MAY BE SOLID. ALL CONDUCTORS #8 AND LARGER SHALL BE STRANDED TYPE.
5. PROVIDE CONTINUITY OF NEUTRAL ON MULTI-BRANCH CIRCUITS BY SPLICING AND BRINGING OUT A TAP, ASSURING NO OPENINGS OF NEUTRAL IN REPLACEMENT OF A DEVICE.
6. COLOR CODE MULTI-CIRCUIT WIRING AS FOLLOWS: NEUTRAL - WHITE, GROUND - GREEN, LINE - ALL OTHER COLORS.
7. INSTALL ONLY HIGH POWER FACTOR BALLASTS AT FLUORESCENT FIXTURES.
8. INSTALL GFI BREAKERS OF DEVICES AT ALL BATHROOM RESTROOM, KITCHEN, GARAGE AND EXTERIOR RECEPTACLES AND AS NOTED ON THE DRAWINGS.
9. INSTALL ONLY THOSE ELECTRICAL DEVICES THAT BEAR A "UL" OR OTHER RECOGNIZED TESTING LAB LABEL. ALL MATERIALS SHALL BE NEW.
10. INSTALL NON-FUSED DISCONNECT SWITCHES AT ALL PIECES OF ELECTRICAL EQUIPMENT LOCATED WHERE SAID EQUIPMENT IS NOT VISIBLE FROM THE CIRCUIT BREAKER-TAKE PROTECTS IT: SIZE IN ACCORD WITH THE LOAD. ALL DISCONNECT SWITCHES SHALL BE HP, RATED, HEAVY DUTY, QUICK-MAKE & QUICK-BREAK TYPE - ENCLOSURES SHALL BE AS REQ'D FOR EXPOSURE.
11. MOTOR STARTERS SHALL BE MANUAL OR MAGNETIC WITH OVERLOAD RELAYS IN EACH HOT LEG.
12. ISOLATE DISSIMILAR CONDUIT AND TUBING METALS FROM SOIL, WATER AND GAS PIPING AND OTHER BUILDING MATERIALS WHERE DAMAGE BY FRICTION OR ELECTROLYSIS MAY OCCUR, EXCEPT WHERE ELECTRICAL GROUND IS PROVIDED.
13. FURNISH AND INSTALL ALL ELECTRICAL DEVICES AND ITEMS REQUIRED FOR A COMPLETE, OPERATING SYSTEM, PROVIDING THE FUNCTIONS AS DETAILED IN THE PLANS (AND SPECS).
14. OUTLET BOXES SHALL BE PRESSED STEEL OR PLASTIC OR ALL DRY LOCATIONS, FOR WET LOCATIONS, CAST ALLOY WITH-THREADED HUB OUTLET BOXES SHALL BE INSTALLED.
15. HOT CHECK ALL SYSTEMS WITH THE OWNER'S REPRESENTATIVE PRESENT TO VERIFY PROPER FUNCTION PRIOR TO C.O.
16. COORDINATE ALL WORK THROUGH GC TO AVOID CONFLICTS. COORDINATE WITH HVAC CONTRACTOR AND ELECTRONICS SYSTEMS CONTRACTORS SO THAT A COMPLETE, FUNCTIONING SYSTEM IS INSTALLED, IN EACH CASE, WITH NO EXTRA COST TO THE OWNER.
17. EMERGENCY LIGHTING AND EXIT SIGNS, IF INDICATED ON THE PLANS, SHALL BE WIRED PER NEC 100-12F.
18. ALL PANEL SCHEDULES SHALL BE FULLY FILLED OUT AND SHALL BE TYPEWRITTEN. EA. CIRCUIT SHALL BE CLEARLY IDENTIFIED A TO WHAT IS INCLUDED ON SAID CIRCUIT.
19. IT IS NOT THE INTENT OF THESE DRAWINGS TO SHOW EVERY MINOR DETAIL OF THE CONSTRUCTION.
20. THE ELECTRICAL INSTALLATION SHALL MEET ALL STANDARD REQUIREMENTS OF THE POWER COMPANY & TELEPHONE COMPANY.
21. FURNISH AND INSTALL DISCONNECT SWITCHES AND WIRING FOR HVAC SYSTEM AS PER MANUFACTURER'S RECOMMENDATIONS. CONTROLS ARE TO BE SUPPLIED BY THE HVAC CONTRACTOR, AND CONNECTED BY THE ELECTRICAL CONTRACTOR.
22. ALL RACEWAYS BELOW GROUND SHALL BE A MINIMUM OF 3/4".
23. ALL CIRCUIT BREAKERS, TWO AND THREE POLE, SHALL BE COMMON TRIP. NO TIE HANDLES OR TANDEMS SHALL BE ACCEPTABLE.
24. ALL FUSES, UNLESS NOTED OTHERWISE ON THE DRAWINGS, SHALL BE CURRENT LIMITED TYPE (CL) RATED 200000 AIC.
25. ELECTRICAL CONTRACTOR SHALL VERIFY ALL COMPONENTS FOR ALL ELECTRICAL APPLICATIONS & DETERMINE THE CORRECTNESS OF SAME. ANY DISCREPANCY SHALL BE REPORTED TO THE OWNER PRIOR TO FABRICATING ANY MATERIALS, ORDERING COMPONENTS OR DOING ANY WORK.
26. CIRCUITS ON PANEL SCHEDULE (AND PLANS) ARE TO DETERMINE LOAD DATA AND SIZE. THE CONTRACTOR SHALL PROVIDE CIRCUITS AND ROUTING OF CONDUITS AND WIRING TO SUIT JOB CONDITIONS, AND BALANCE THE JOB, THROUGHOUT.
27. CHECK EQUIPMENT FOR PROPER VOLTAGE, PHASE AND AMPERAGE RATINGS PRIOR TO CONNECTION TO CIRCUITS.
28. PANEL BOARDS SHALL BE CIRCUIT BREAKER TYPE. VERIFY NUMBER AND SIZES OF CIRCUITS.
29. WHEN CONDUIT RUNS EXCEED 200 FEET, FULL BOXES SHALL BE INSTALLED SO THAT NO FULL EXCEEDS THIS DISTANCE.
30. ELECTRICAL EQUIPMENT AIC RATING AND FEEDER SIZE SHOWN ON THE PLANS ARE DESIGNED FOR MAX. AVAILABLE FAULT CURRENT AND MAX. ALLOWABLE VOLTAGE DROP, RESPECTIVELY.

These drawings, as instruments of service, are the sole property of the architect, and may not be used, copied or reproduced in whole or in part for use on or incorporated into any other job, without specific and individual authorization by the architect.

REVISION:
Copyright 2005
N.P. Geider, Architect
DRAWN:
DJR

Custom Designed Home for:
DANIEL & MICHELLE STAGG
COLUMBIA COUNTY, FLORIDA
GENERAL NOTES

ADD
ARCHITECTURAL DRAFTING & DESIGN, INC.
ARCHITECTURAL DRAFTING & DESIGN, INC.
Lake City, FL 32025 - 386.752.4870

NE
NICHOLS ARCHITECTS
1-758 NW Brown Rd.
Lake City, FL 32025
386-752-6022
ARCHITECTS
A.R.C.H.I.T.E.C.T.S.
N.C.

DATE:
20NOV2007
COMM:

SHEET:
A.14
14 OF 15

AR0007005

GENERAL STRUCTURAL NOTES

GENERAL:

- 1. THE DRAWINGS ARE INTENDED TO SHOW THE GENERAL ARRANGEMENT, DESIGN AND EXTENT OF THE WORK AND ARE PARTIALLY DIAGRAMMATIC. THEY ARE NOT INTENDED TO BE SCALED FOR ROUGH-IN MEASUREMENTS, OR TO SERVE AS SHOP DRAWINGS OR PORTIONS THEREOF.
2. ALL DETAILS AND SECTIONS SHOWN ON THE DRAWINGS ARE INTENDED TO BE TYPICAL AND SHALL BE CONSTRUED TO APPLY TO ANY SIMILAR SITUATION ELSEWHERE ON THE PROJECT, EXCEPT WHERE A DIFFERENT DETAIL OR SECTION IS SHOWN.
3. PRIOR TO START OF CONSTRUCTION, THE CONTRACTOR AND ALL THE SUBCONTRACTORS SHALL VERIFY ALL GRADES, LINES, LEVELS, DIMENSIONS AND COORDINATE EXISTING CONDITIONS AT THE JOB SITE WITH THE PLANS AND SPECIFICATIONS. THEY SHALL REPORT ANY INCONSISTENCIES OR ERRORS IN THE ABOVE TO THE ARCHITECT/ENGINEER BEFORE COMMENCING WORK. THE CONTRACTOR AND HIS SUBCONTRACTORS SHALL LAY OUT THEIR WORK FROM ESTABLISHED REFERENCE POINTS AND BE RESPONSIBLE FOR ALL LINES, ELEVATIONS AND MEASUREMENTS IN CONNECTION WITH THEIR WORK.
4. IF ANY ERRORS OR OMISSIONS APPEAR IN THE DRAWINGS, GENERAL NOTES OR OTHER DOCUMENTS, THE CONTRACTOR SHALL NOTIFY THE ENGINEER IN WRITING OF SUCH OMISSION OR ERROR PRIOR TO PROCEEDING WITH ANY WORK WHICH APPEARS IN QUESTION. IN THE EVENT OF THE CONTRACTOR'S FAILING TO GIVE SUCH AN ADVANCED NOTICE, HE SHALL BE HELD RESPONSIBLE FOR THE RESULTS OF ANY SUCH ERRORS OR OMISSIONS AND THE COST OF RECTIFYING THE SAME.
5. THE CONTRACTOR SHALL USE THE STRUCTURAL DRAWINGS AND SPECIFICATIONS TOGETHER WITH THE ARCHITECTURAL, MECHANICAL, ELECTRICAL AND OTHER TRADE DRAWINGS AND SHOP DRAWINGS, TO LOCATE DERESSED SLABS, SLOPES, DRAINS, OUTLETS, RECESSES, OPENINGS, BOLT SETTING, SLEEVES, DIMENSIONS, ETC. NOTIFY ARCHITECT/ENGINEER IN WRITING, OF ANY POTENTIAL CONFLICTS BEFORE PROCEEDING WITH THE WORK.

SHOP DRAWINGS AND DELEGATED ENGINEERING:

- 1. ALL SHOP DRAWINGS SHALL BE SUBMITTED FOR ENGINEER'S REVIEW ONLY AFTER THEY HAVE BEEN THOROUGHLY REVIEWED BY THE CONTRACTOR FOR CONSTRUCTION METHODS, DIMENSIONS AND OTHER TRADE REQUIREMENTS, AND STAMPED WITH THE CONTRACTOR'S APPROVAL STAMP. THE ARCHITECT ASSUMES NO RESPONSIBILITY FOR DIMENSIONS, QUANTITIES, ENGINEERING DESIGN BY DELEGATED ENGINEERS, ERRORS OR OMISSIONS AS A RESULT OF REVIEWING ANY SHOP DRAWINGS. ANY ERRORS OR OMISSIONS MUST BE MADE GOOD BY THE CONTRACTOR, IRRESPECTIVE OF RECEIPT, CHECKING OR REVIEW OF DRAWINGS BY THE ARCHITECT AND EVEN THOUGH WORK IS DONE IN ACCORDANCE WITH SUCH DRAWINGS.
2. BEFORE STRUCTURAL INSPECTIONS CAN BE MADE ON A PORTION OF THE STRUCTURE, ALL RELATED SHOP DRAWINGS, DELEGATED ENGINEERING, PRODUCT APPROVAL, MANUFACTURER'S DATA AND OTHER RELATED INFORMATION, MUST BE REVIEWED AND ACCEPTED BY THE ARCHITECT-OF-RECORD AND APPROVED BY THE BUILDING DEPARTMENT.
3. SHOP DRAWINGS SHALL CONTAIN ALL INFORMATION SHOWN ON THE STRUCTURAL PLANS (RELATED TO THE DELEGATED DESIGN) INCLUDING ALL DESIGN LOADS, IN ADDITION TO THE INFORMATION REQUIRED BY THE DELEGATED ENGINEER'S DESIGN.
4. A/E WILL REVIEW ALL SUBMITTED SHOP DRAWINGS, PREPARED AND SIGNED AND SEALED BY THE CONTRACTOR'S DELEGATED ENGINEER, ONLY FOR GENERAL COMPLIANCE WITH THE DESIGN INTENT, REQUIRED LOADING AND COORDINATION WITH THE STRUCTURAL DESIGN.
5. CONTRACTOR SHALL SUBMIT TO THE A/E ONLY ONE SET OF SEP1A AND TWO SETS OF BLUE PRINTS OF THE STRUCTURAL SHOP DRAWINGS FOR A/E REVIEW, BEFORE STARTING FABRICATION. THE A/E WILL RETURN THE MARKED-UP AND STAMPED SEP1A TO THE CONTRACTOR. THESE SEP1A COPIES SHALL BE USED TO MAKE THE PRINTS REQUIRED FOR SHOP DRAWING DISTRIBUTION. SETS OF BLUE PRINTS (WITHOUT SEP1A) WILL NOT BE ACCEPTED.

CONSTRUCTION MEANS AND METHODS:

- 1. THE CONSTRUCTION MEANS, METHODS, TECHNIQUES, SEQUENCE OR PROCEDURES, SAFETY PRECAUTIONS, SHORES, RESHORES, LATERAL BRACING AND PROGRAMS IN CONNECTION WITH THE PROJECT, ARE THE SOLE RESPONSIBILITY OF THE CONTRACTOR. OUR SERVICES DO NOT GUARANTEE NOR ASSURE LIABILITY FOR THE JOB SAFETY, TEMPORARY SHORING AND BRACING AND THE PERFORMANCE OF THE CONTRACTOR.
2. THE CONTRACTOR IS RESPONSIBLE AND SHALL COMPLY WITH THE SAFETY REQUIREMENTS OF THE STANDARD BUILDING CODE AND APPLICABLE LOCAL, STATE AND FEDERAL LAIS.
3. PROVIDE ALL SHORING, BRACING AND SHEETING AS REQUIRED FOR SAFETY, STRUCTURAL STABILITY AND FOR THE PROPER EXECUTION OF THE WORK. REMOVE WHEN WORK IS COMPLETED.
4. PROVIDE AND MAINTAIN GUARD LIGHTS AT ALL BARRICADES, RAILINGS, OBSTRUCTIONS IN THE STREETS, ROADS OR SIDEWALKS AND ALL TRENCHES OR PITS ADJACENT TO PUBLIC WALKS OR ROADS.
5. AT ALL TIMES, PROVIDE PROTECTION AGAINST WEATHER (RAIN, WIND, STORMS OR THE SUN), SO AS TO MAINTAIN ALL WORK, MATERIALS, APPARATUS AND FIXTURES FREE FROM INJURY OR DAMAGE.
6. AT THE END OF THE DAYS WORK, COVER ALL WORK LIKELY TO BE DAMAGED. ANY WORK DAMAGED BY FAILURE TO PROVIDE PROTECTION SHALL BE REMOVED AND REPLACED WITH NEW WORK AT THE CONTRACTOR'S EXPENSE.
7. THE CONTRACTOR SHALL PAY FOR ALL DAMAGES TO ADJACENT STRUCTURES, SIDEWALKS AND TO STREETS OR OTHER PUBLIC PROPERTY OR PUBLIC UTILITIES.

STRUCTURAL DESIGN CRITERIA:

- 1. THE DESIGN COMPLIES WITH THE REQUIREMENTS OF THE STANDARD BUILDING CODE - 1997 EDITION AND OTHER REFERENCED CODES AND SPECIFICATIONS. ALL CODES AND SPECIFICATIONS SHALL BE LATEST EDITION AT TIME OF PERMIT.
2. WIND LOAD CRITERIA:
BASED ON SBCCI 1606 BASIC WIND VELOCITY 110 MPH.
3. ROOF DESIGN LOADS:
COMPOSITE DEAD LOADS: 15 PSF
SUPERIMPOSED LIVE LOADS: 30 PSF
4. FLOOR DESIGN LOADS:
COMPOSITE DEAD LOADS: 25 PSF
SUPERIMPOSED LIVE LOADS:
RESIDENTIAL 40 PSF
BALCONIES 60 PSF
5. WIND NET UPLIFT: ARE AS INDICATED ON PLANS

FOUNDATIONS: (SPREAD FOOTINGS)

- 1. FOUNDATIONS ARE DESIGNED TO BEAR ON WELL COMPACTED GRADE OR CLEAN FILL OF AN ALLOWABLE BEARING CAPACITY OF 1000 PSF MAXIMUM. A CERTIFIED TESTING LABORATORY SHALL BE ENGAGED BY THE OWNER TO VERIFY THAT THE REQUIRED BEARING CAPACITY WAS OBTAINED. SAID SOIL CAPACITY SHALL BE CERTIFIED AND TESTED BY A FLORIDA REGISTERED FOUNDATION ENGINEER, PRIOR TO CASTING OF CONCRETE IN THE FOOTINGS.
2. NATURAL GRADE (OR FILL) BELOW FOOTINGS SHALL BE COMPACTED TO 98% MODIFIED PROCTOR (ASTM D-1557).
3. TOP OF WALL FOOTINGS TO BE AT THE SAME ELEVATION AS TOP OF COLUMN PAD FOOTINGS. STEP WALL FOOTING FROM HIGHER COLUMN FOOTING TO THE LOWER ONE (AS DETAILED ON THE PLANS).
4. TOP OF ALL FOOTINGS TO BE A MINIMUM 1'-4" BELOW THE TOP OF CONCRETE SLAB ON GRADE (UNLESS OTHERWISE NOTED) OR MINIMUM 1'-0" BELOW FINISHED GRADE, WHICHEVER IS LOWER. IN THE EVENT THAT THE SLAB STEPS ON EACH SIDE OF THE FOOTING, THE FOOTING SHALL BE 1'-4" BELOW TOP OF THE LOWER SLAB.
5. REINFORCING IN THE CONTINUOUS WALL FOOTINGS (MONOLITHIC AND NON-MONOLITHIC) SHALL BE SPICED 3/8 BAR DIAMETERS MINIMUM AND SHALL EXTEND CONTINUOUSLY THRU ALL FOOTING PADS.
6. ALL LONGITUDINAL REBARS IN THE CONTINUOUS WALL FOOTINGS, SHALL BE CONTINUED AT BENTS AND CORNERS BY BENDING THE REBARS 48 BAR DIAMETERS AROUND THE CORNERS OR ADDING MATCHING CORNER BARS, EXTENDING 48 BAR-DIAMETERS INTO FOOTING EACH SIDE OF CORNER OR BENT.
7. ALL FOOTINGS SHALL BE 12" MINIMUM THICKNESS.

CONCRETE SLABS ON GRADE:

- 1. ALL INTERIOR AND EXTERIOR SLABS AND WALKWAYS AS SHOWN ON THE STRUCTURAL OR ARCHITECTURAL PLANS, SHALL BE FOUR INCHES THICK MINIMUM REINFORCED WITH 6 X 6 - W/4 X W/4 WELDED WIRE FABRIC (UNLESS OTHERWISE NOTED).
2. ALL SLABS ON GRADE TO BE CONSTRUCTED IN ACCORDANCE WITH LATEST A.C.I. - "GUIDE FOR CONCRETE FLOOR AND SLAB CONSTRUCTION" (A.C.I. - 302.1R).
3. JOINTS SHALL BE PROVIDED IN ALL INTERIOR SLABS ON GRADE AT COLUMN CENTER-LINES DIVIDING THE SLAB INTO SQUARE PANELS NOT TO EXCEED 20 X 20 FT. IN SIZE. CAST SLAB IN LONG ALTERNATE STRIPS. PROVIDE A CONTRACTION JOINT BETWEEN EACH STRIP. SEE PLAN FOR SAW-CUT, CONTRACTION AND ISOLATION JOINT DETAILS.
4. PROVIDE SAW-CUT JOINTS AT ALL SIDEWALKS AT A MAXIMUM SPACING OF FIVE FEET ON CENTERS AND ISOLATION JOINTS AT 20 FEET O.C. (U.O.N.).
5. FILL MATERIAL SHALL BE PLACED IN LIFTS NOT EXCEEDING 12" AND COMPACTED TO 98% MODIFIED PROCTOR (ASTM D-1557) EXTENDING A DISTANCE OF 3 FEET BEYOND ALL FOOTING EDGES. TAKE AT LEAST ONE DENSITY TEST FOR EACH 1000 SQFT. OF AREA AND 12" BELOW SURFACE. SEND RESULTS OF THE TEST TO OWNER, ARCHITECT (AND ENGINEER).
6. CONCRETE DESIGN AND REINFORCEMENT IN ACCORDANCE WITH "BUILDING CODE REQUIREMENTS FOR REINFORCED CONCRETE" (A.C.I. 318 - LATEST EDITION) AND WITH "DETAILS AND DETAILING OF CONCRETE REINFORCEMENT" - (A.C.I. 315 - LATEST EDITION).
7. ALL CONCRETE TO BE REGULAR WEIGHT WITH A DESIGN STRENGTH OF 3000 P.S.I. AT 28 DAYS. "MAXIMUM SLUMPS 5".
8. ALL REINFORCING TO BE NEW BILLET STEEL CONFORMING TO THE LATEST A.S.T.M. A-615 GRADE 60, FABRICATED IN ACCORDANCE WITH C.R.S.I. MANUAL OF STANDARD PRACTICE AND PLACED IN ACCORDANCE WITH A.C.I. 318 AND C.R.S.I. MANUAL OF STANDARD PRACTICE.
9. CONCRETE COVER UNLESS OTHERWISE DETAILED ON DRAWINGS:
FOOTINGS: (BOTTOM) ..... 3"
(TOP 4 SIDES) ..... 2"
SLABS ON GRADE: CENTERED W/SLAB
COLUMNS AND BEAMS: (TO THE TIES) ..... 1-1/2"

CONCRETE AND REINFORCING:

- 1. CONCRETE DESIGN AND REINFORCEMENT IN ACCORDANCE WITH "BUILDING CODE REQUIREMENTS FOR REINFORCED CONCRETE" (A.C.I. 318 - LATEST EDITION) AND WITH "DETAILS AND DETAILING OF CONCRETE REINFORCEMENT" - (A.C.I. 315 - LATEST EDITION).
2. ALL CONCRETE WORK IN ACCORDANCE WITH "SPECIFICATIONS FOR STRUCTURAL CONCRETE FOR BUILDING" (A.C.I. 301 - LATEST EDITION). PRODUCTION OF CONCRETE, DELIVERY, PLACING AND CURING TO BE IN ACCORDANCE WITH "HOT WEATHER CONCRETING" (A.C.I. 309R - LATEST EDITION).
3. ALL CONCRETE TO BE REGULAR WEIGHT WITH A DESIGN STRENGTH OF 3000 P.S.I. AT 28 DAYS. "MAXIMUM SLUMPS 5".
4. ALL REINFORCING TO BE NEW BILLET STEEL CONFORMING TO THE LATEST A.S.T.M. A-615 GRADE 60, FABRICATED IN ACCORDANCE WITH C.R.S.I. MANUAL OF STANDARD PRACTICE AND PLACED IN ACCORDANCE WITH A.C.I. 318 AND C.R.S.I. MANUAL OF STANDARD PRACTICE.
5. CONCRETE COVER UNLESS OTHERWISE DETAILED ON DRAWINGS:
FOOTINGS: (BOTTOM) ..... 3"
(TOP 4 SIDES) ..... 2"
SLABS ON GRADE: CENTERED W/SLAB
COLUMNS AND BEAMS: (TO THE TIES) ..... 1-1/2"
6. COLUMN REINFORCEMENT: DOWELS TO BE SAME SIZE AND NUMBER AS VERTICAL REBARS ABOVE. LAP 3/8 BAR DIAMETER OR MINIMUM OF 18 INCHES, U.O.N. PROVIDE RIGID TEMPLATES FOR DOWEL LOCATION. PROVIDE STANDARD HOOKS AT TOP OF ALL VERTICAL REINFORCEMENT AT NONCONTINUOUS COLUMNS (U.O.N.).
7. ALL DOWELS FOR COLUMNS SHALL BE SECURED IN POSITION PRIOR TO CONCRETING. PUSHING THE DOWELS INTO POSITION IN WET CONCRETE IS NOT PERMITTED.
8. BEAM REINFORCEMENT: LAPPED 3/8 BAR DIAMETER OR MINIMUM 18 INCHES. BOTTOM BARS SPICED ONLY AT SUPPORTS, TOP BARS SPICED ONLY AT MID-SPAN. ALL TOP BARS HOOKED AT NONCONTINUOUS EDGES (U.O.N.). ALL HOOKS TO BE STANDARD 90 DEGREE HOOKS AS REQUIRED (U.O.N.).
9. ADDED REINFORCEMENT: PROVIDE ADDITIONAL CORNER BARS BENT 3/8 INCHES MINIMUM EACH WAY AT "L" AND "T" CORNERS IN OUTER FACES OF ALL BEAMS TO MATCH ALL HORIZONTAL I-BAR (TOP, BOTTOM AND INTERMEDIATE REBARS).
10. SEE PLAN FOR MINIMUM SIZE CONCRETE TIE BEAM REQUIREMENTS.

REINFORCED MASONRY WALLS:

- 1. HOLLOW LOAD-BEARING MASONRY UNITS SHALL CONFORM TO ASTM C-90, TYPE 1, GRADE N, SQUARE END, WITH A MINIMUM AVERAGE COMPRESSIVE STRENGTH ON NET AREA OF 1"=2,000 (PSI). CONSTRUCTION SHALL BE IN ACCORDANCE WITH ACI 530.1 SPECIFICATIONS.
2. SPECIAL INSPECTOR SERVICES ARE REQUIRED FOR ALL REINFORCED MASONRY CONSTRUCTION. THE SPECIAL INSPECTOR SHALL INSPECT THE PLACING OF THE REBARS IN THE CELLS, VERIFY CLEANLINESS OF THE CELLS TO BE GROUTED, AND OBSERVE THE PLACING OF THE GROUT OR CONCRETE INTO THE CELLS.

3. MORTAR SHALL CONFORM TO ASTM C-270, TYPE "M" OR "S".

- 4. LAY ALL MASONRY WITH FULL FACE HEAD JOINTS AND WITH FACE SHELL MORTAR BEDDING.
5. MASONRY ANCHORAGE TO SUPERSTRUCTURE SHALL BE PROVIDED IN ACCORDANCE WITH STRUCTURAL DRAWINGS AND DETAILS.
6. THE USE OF ADMIXTURES SHALL NOT BE PERMITTED WITHOUT PRIOR REVIEW OF THE ENGINEER.

- 7. VERTICAL REINFORCING:
(A) ASTM A-615 PER REINFORCING SECTION.
(B) WHEN A FOUNDATION DOUEL DOES NOT LINE UP WITH A VERTICAL CORE IT SHALL NOT BE SLOPED MORE THAN ONE HORIZONTAL INCH TO SIX INCHES VERTICAL FOR ALIGNMENT, EVEN THOUGH IT IS IN A CELL ADJACENT TO THE VERTICAL WALL REINFORCING.
(C) VERTICAL REINFORCING STEEL SHALL BE PLACED CENTERED IN THE CELL. LAP 48 BAR-DIAMETERS. PROVIDE BAR SPACERS AS REQUIRED TO MAINTAIN REINFORCING SECURED IN POSITION.
(D) VERTICAL REINFORCEMENT SHALL BE PROVIDED AT EACH SIDE OF OPENINGS IN WALL, AT WALL INTERSECTIONS, CORNERS AND ENDS. THIS REINFORCING SHALL BE THE SAME SIZE AS THE SCHEDULED WALL REINFORCING FOR THE PARTICULAR WALL BUT NEVER LESS THAN A #5 REBAR. SPECIAL CARE SHALL BE TAKEN TO INSURE THAT CELLS TO BE GROUTED LINE UP PROPERLY AND ARE CLEAN OF EXCESS MORTAR.
(E) ALL VERTICAL REINFORCING SHALL BE HOOKED INTO THE BOND BEAMS AT THE NON-CONTINUOUS END OF THE REBARS.

- (F) PROVIDE INSPECTION HOLES AT THE BOTTOM OF EACH REINFORCED MASONRY CELL, AS REQUIRED FOR LIFTS HIGHER THAN 5 FT.
8. HORIZONTAL REINFORCING:
PROVIDE GALVANIZED #3 GAGE, LADDER TYPE HORIZONTAL JOINT REINFORCING EVERY SECOND BLOCK COURSE (1'-4" O.C. VERTICALLY) LAPPED 1'-1/2". PROVIDE SPECIAL HORIZONTAL REINFORCING AT "T" AND "L" INTERSECTION. ANCHOR TO COLUMNS WITH MINIMUM 4" EXTENSION INTO AREA OF FOUR.

- 9. PROVIDE "DOVE-TAIL" ANCHORS AT 16" O.C. VERTICALLY FOR ALL MASONRY PLACED ADJACENT TO ALREADY IN PLACE COLUMNS.
10. CELL FILLING CONCRETE SHALL BE "FEA DECK" CONCRETE MIX (8" TO 9" SLUMP) OR GROUT WITH f'c=3,500 PSI MIN. AT 28 DAYS.
11. LINTELS:
(A) THE CONTRACTOR SHALL PROVIDE PRECAST CONCRETE OR CAST-IN-SITE LINTELS AT THE HEADS OF ALL OPENINGS IN MASONRY WALLS NOT EXCEEDING SIX (6) FEET IN WIDTH WHERE BEAMS HAVE NOT BEEN SPECIFIED. FOR OPENING ADJACENT TO CONCRETE COLUMNS - THE LINTEL SHALL BE CAST-IN-PLACE WITH THE COLUMN.

- B. LINTEL MAY BE INTEGRAL WITH THE STRUCTURAL OR TIE BEAM WHEN HEAD OF THE OPENING IS 16 INCHES OR LESS BELOW. CONTINUE BEAM'S TYPICAL BOTTOM REBARS THROUGH AND ADD 2-#5 BOTTOM TRUSS BARS AT DROPS AND 2-#3 STIRRUPS AT 6 INCHES O.C. EACH END AT DROP.
C. MINIMUM BEARING FOR ALL LINTELS 8 INCHES EACH SIDE OR PROVIDE DOWELS AND POCKETS IN ADJACENT CONCRETE COLUMNS.

- D. LINTEL TO BE MINIMUM OF 8 INCHES DEEP WITH 2-#4 TOP AND BOTTOM FOR CLEAR SPANS LESS THAN 6 FEET; 12 INCHES DEEP WITH 2-#5 TOP AND BOTTOM AND 2-#3 STIRRUPS AT 6 INCHES O.C. EACH END, FOR SPANS GREATER THAN 6 FEET (UP TO 8 FEET). CALL ARCHITECT FOR SPANS LARGER THAN 8 FEET WITH NO SPECIFIED BEAMS OR LINTELS OVER.

- 12. TUBE TUBES TO BE DOMESTIC STEEL CONFORMING TO A.S.T.M. A-500 GRADE B (Fy=46 KSI.).
TUBE AND PIPE COLUMNS TO BE CONCRETE FILLED WITH VENT HOLES TOP, MIDDLE AND BOTTOM.

- 13. ALL COLUMN BASE AND CAP PLATES SHALL BE 3/4" THICK (UNLESS OTHERWISE NOTED). WIDTH AND LENGTH AS REQUIRED FOR PROPER BOLTING AND AS INDICATED ON THE PLANS AND DETAILS.
14. ALL WELDING TO BE IN ACCORDANCE WITH AWS, LATEST "STRUCTURAL WELDING CODE - STEEL". CLEAN AND RUSTPROOF ALL FIELD WELDS WITH HEAVY DUTY RUSTPROOFING PAINT.

- 15. ALL CONNECTIONS TO BE FIELD AND SHOP WELDED AND TO DEVELOP MEMBER IN SHEAR.
16. SPlice LOCATIONS TO BE REVIEWED BY ARCHITECT/ENGINEER.

STRUCTURAL WOOD:

- 1. TO CONFORM TO RULES OF THE MANUFACTURER'S ASSOCIATION UNDER WHOSE RULES THE LUMBER IS PRODUCED. (SEE SUPPLIER'S SPECIFICATIONS).
2. TO BE AIR DRIED, WELL SEASONED AND GRADE MARKED AT MILL.
3. TO BE NO. 2 SOUTHERN PINE, UTILITY GRADE DOUGLAS FIR OR WEST COAST HEMLOCK.
4. ALL STRUCTURAL WOOD TO BE SURFACED FOUR (4) SIDES (S-4-S) WITH A MINIMUM FIBER STRESS IN BENDING OF 1200 P.S.I. AND A MAXIMUM MOISTURE CONTENT OF 19 PERCENT.
5. ALL LUMBER AND PLYWOOD IN CONTACT WITH CONCRETE, STUCCO, MASONRY OR OTHER CEMENTITIOUS MATERIALS SHALL BE TREATED TO COMPLY WITH AUPA STANDARD LP-2.
6. STORE ALL LUMBER ABOVE GRADE OR FLOOR. STACK TO ALLOW PROPER AIR CIRCULATION AND PROTECT FROM WETTING WITH SUITABLE COVER.

WOOD TRUSSES: (DELEGATED ENGINEERED SHOP DRAWING REQUIRED)

- 1. DESIGNED AND FABRICATED IN ACCORDANCE WITH NATIONAL DESIGN SPECIFICATIONS FOR STRESS GRADE LUMBER AND ITS FASTENERS BY NFPA (LATEST REVISION).
2. TRUSSES SHALL BE DESIGNED, SIGNED AND SEALED BY A FLORIDA REGISTERED PROFESSIONAL ENGINEER, WHO SHALL BE ASSIGNED AS A DELEGATED ENGINEER FOR THE CONTRACTOR. THE DELEGATED ENGINEER DESIGN AND INDICATE ON THE SHOP DRAWINGS ALL TRUSS COMPONENTS, TEMPORARY BRACING, BRIDGING, HARDWARE, METAL HANGERS, ANCHORS AND METAL SHAPES AS REQUIRED BY DESIGN OR AS INDICATED ON THE PLANS. ALL METAL PARTS TO BE GALVANIZED.
3. TRUSS DESIGNER ENGINEER SHALL INDICATE THE NET WIND UPLIFT REACTIONS FOR EACH TRUSS AND GIRDER TRUSS. EACH TRUSS SHALL BE STRAPPED TO THE SUPPORT WITH A HURRICANE STRAP (AS PER DETAIL ON PLAN). THE SIZE OF STRAP AND AMOUNT OF NAILS SHALL BE SELECTED BASED ON THE UPLIFT DATA OF THE STRAP AND THE TRUSS SHOP DRAWINGS.
4. ALL SEATS FOR THE WOOD GIRDER TRUSSES HAVE BEEN SPECIFIED BY THE A/E IN COORDINATION WITH LOCATION AND LOADING INFORMATION PROVIDED ON THE PRE-ENGINEERED WOOD TRUSS SHOP DRAWINGS.
5. THE STRUCTURAL PLANS INDICATE ALL THE REQUIRED LATERAL PERMANENT BRIDGING, AS RECOMMENDED BY THE "TRUSS PLATE INSTITUTE". TRUSS DESIGNER ENGINEER SHALL PROVIDE INFORMATION AND SHOW ON PLAN, ALL LATERAL BRACING OF ANY TRUSS INDIVIDUAL MEMBERS, AS REQUIRED BY TRUSS DESIGN.
6. TRUSSES SHALL BE INSTALLED WITH OUT OF PLUMB AND OUT OF PLANE TOLERANCES, AS PER THE "TRUSS PLATE INSTITUTE" (SHOWN ON THE ROOF PLAN). ANY TRUSS EXCEEDING THE SPECIFIED TOLERANCE MUST BE REALIGNED OR REPLACED.
7. INSTALLATION OF TRUSSES LONGER THAN 35 FT. OR HIGHER THAN 6 FT. SHALL BE MADE UNDER THE DIRECT SUPERVISION OF A LICENSED BUILDING OR GENERAL CONTRACTOR OR A LICENSED STRUCTURAL ENGINEER OR ARCHITECT.

- 1. DESIGN SOIL BEARING PRESSURE: 1000 PSF.
2. EXPANSIVE SOILS: WHERE DIRECTED BY THE SOILS ENGINEER, SOIL AUGMENTATION PER THE SOILS ENGINEER'S SPECIFICATIONS SHALL BE IMPLEMENTED PRIOR TO PLACING ANY FOUNDATIONS - TESTS AS SPECIFIED SHALL BE PERFORMED TO DETERMINE THE SUITABILITY OF THE SUB-GRADE TO SUPPORT THE DESIGN LOADS.
3. CLEAN SAND FILL OVER STRIPPED AND COMPACTED EXISTING GD. SHALL BE PLACED IN 12" LIFTS, BOTH SUB-SOIL AND FILL COMPACTION SHALL BE NOT LESS THAN 98% AS MEASURED BY A MODIFIED PROCTOR TEST AT THE RATE OF ONE TEST FOR EACH 2500 SF OF BUILDING PAD AREA, OR FRACTION THEREOF, FOR EACH 12" LIFT.
4. REINFORCING STEEL SHALL BE GRADE 40 AND MEET THE REQUIREMENTS OF ASTM A615, ALL BENDS SHALL BE MADE COLD.
5. WELDED WIRE MESH SLAB REINFORCING SHALL MEET THE REQUIREMENTS OF ASTM A105 - MIN. YIELD STRESS = 85 KSI.
6. CONCRETE SHALL BE STANDARD MIX F'c = 2500 PSI FOR ALL FTGS. SLABS, COLUMNS AND BEAMS OR SHALL BE STANDARD PUMP MIX F'c = 3000 PSI. STRENGTH SHALL BE ATTAINED WITHIN 28 DAYS OF PLACEMENT, MIXING, PLACING AND FINISHING SHALL BE AS PER ACI STANDARDS.
7. CONCRETE BLOCK SHALL BE AS PER MANUFACTURER'S PRODUCT GUIDE FOR ASTM C-90 REQUIREMENTS WITH MEDIUM SURFACE FINISH - F'm = 1500 PSI.
8. MORTAR SHALL BE TYPE "M" OR "N" FOR ALL MASONRY UNITS.
9. STRUCTURAL STEEL SHALL CONFORM TO ASTM A36 STANDARD'S FOR STRENGTH. BOLTS SHALL BE ASTM A307 / GRADE I OR A325, AS PER PLAN REQUIREMENTS.
10. WELDS SHALL BE AS PER "AMERICAN WELDING SOCIETY" STANDARDS FOR STRUCTURAL STEEL APPLICATIONS.

- 11. STEEL BEARING ON STEEL TO BE WELDED THERETO.
12. TUBE TUBES TO BE DOMESTIC STEEL CONFORMING TO A.S.T.M. A-500 GRADE B (Fy=46 KSI.).
TUBE AND PIPE COLUMNS TO BE CONCRETE FILLED WITH VENT HOLES TOP, MIDDLE AND BOTTOM.

- 13. ALL COLUMN BASE AND CAP PLATES SHALL BE 3/4" THICK (UNLESS OTHERWISE NOTED). WIDTH AND LENGTH AS REQUIRED FOR PROPER BOLTING AND AS INDICATED ON THE PLANS AND DETAILS.
14. ALL WELDING TO BE IN ACCORDANCE WITH AWS, LATEST "STRUCTURAL WELDING CODE - STEEL". CLEAN AND RUSTPROOF ALL FIELD WELDS WITH HEAVY DUTY RUSTPROOFING PAINT.

- 15. ALL CONNECTIONS TO BE FIELD AND SHOP WELDED AND TO DEVELOP MEMBER IN SHEAR.
16. SPlice LOCATIONS TO BE REVIEWED BY ARCHITECT/ENGINEER.

PLYWOOD ROOF DIAPHRAGM:

- 1. ROOF DIAPHRAGM SHALL COMPLY WITH THE DESIGN RECOMMENDATIONS OF "A.P.A. DESIGN/CONSTRUCTION GUIDE - DIAPHRAGMS" AND THE LOCAL BUILDING CODE.
2. PLYWOOD ROOF DECKING SHALL BE 1/2" CDX PLYWD. OR 7/16" OSB AND SHALL BE CONTINUOUS OVER TWO OR MORE SPANS, WITH FACE GRAIN PERPENDICULAR TO THE SUPPORTS.
3. CONNECT PLYWOOD DIAPHRAGM TO STRUCTURE WITH 10d GALV. NAILS, SPACED AT 6" O.C. MAX. AT SUPPORTED EDGES AND AT 8" O.C. ALONG THE INTERMEDIATE SUPPORTS.
4. INSPECTIONS: COMPLY WITH THE LOCAL BUILDING CODE AND OTHER REQUIREMENTS FOR INSPECTIONS (BY THE COUNTY, CITY, ARCHITECT OR ENGINEER) OF SPECIFIED COMPONENTS OF THE ROOF STRUCTURE REQUIRING INSPECTIONS.

- 5. GABLE ENDS NAIL SPACING SHALL BE 4" ON CENTERS MAXIMUM.
6. INSPECTIONS: COMPLY WITH THE LOCAL BUILDING CODE AND OTHER REQUIREMENTS FOR INSPECTIONS (BY THE COUNTY, CITY, ARCHITECT OR ENGINEER) OF SPECIFIED COMPONENTS OF THE ROOF STRUCTURE REQUIRING INSPECTIONS.

- 7. GABLE ENDS NAIL SPACING SHALL BE 4" ON CENTERS MAXIMUM.
8. INSPECTIONS: COMPLY WITH THE LOCAL BUILDING CODE AND OTHER REQUIREMENTS FOR INSPECTIONS (BY THE COUNTY, CITY, ARCHITECT OR ENGINEER) OF SPECIFIED COMPONENTS OF THE ROOF STRUCTURE REQUIRING INSPECTIONS.

SUMMARY
REFER TO MAIN TEXT FOR EXPANDED NOTES
CONCRETE / MASONRY / METALS GENERAL NOTES:
1. DESIGN SOIL BEARING PRESSURE: 1000 PSF.
2. EXPANSIVE SOILS: WHERE DIRECTED BY THE SOILS ENGINEER, SOIL AUGMENTATION PER THE SOILS ENGINEER'S SPECIFICATIONS SHALL BE IMPLEMENTED PRIOR TO PLACING ANY FOUNDATIONS - TESTS AS SPECIFIED SHALL BE PERFORMED TO DETERMINE THE SUITABILITY OF THE SUB-GRADE TO SUPPORT THE DESIGN LOADS.
3. CLEAN SAND FILL OVER STRIPPED AND COMPACTED EXISTING GD. SHALL BE PLACED IN 12" LIFTS, BOTH SUB-SOIL AND FILL COMPACTION SHALL BE NOT LESS THAN 98% AS MEASURED BY A MODIFIED PROCTOR TEST AT THE RATE OF ONE TEST FOR EACH 2500 SF OF BUILDING PAD AREA, OR FRACTION THEREOF, FOR EACH 12" LIFT.
4. REINFORCING STEEL SHALL BE GRADE 40 AND MEET THE REQUIREMENTS OF ASTM A615, ALL BENDS SHALL BE MADE COLD.
5. WELDED WIRE MESH SLAB REINFORCING SHALL MEET THE REQUIREMENTS OF ASTM A105 - MIN. YIELD STRESS = 85 KSI.
6. CONCRETE SHALL BE STANDARD MIX F'c = 2500 PSI FOR ALL FTGS. SLABS, COLUMNS AND BEAMS OR SHALL BE STANDARD PUMP MIX F'c = 3000 PSI. STRENGTH SHALL BE ATTAINED WITHIN 28 DAYS OF PLACEMENT, MIXING, PLACING AND FINISHING SHALL BE AS PER ACI STANDARDS.
7. CONCRETE BLOCK SHALL BE AS PER MANUFACTURER'S PRODUCT GUIDE FOR ASTM C-90 REQUIREMENTS WITH MEDIUM SURFACE FINISH - F'm = 1500 PSI.
8. MORTAR SHALL BE TYPE "M" OR "N" FOR ALL MASONRY UNITS.
9. STRUCTURAL STEEL SHALL CONFORM TO ASTM A36 STANDARD'S FOR STRENGTH. BOLTS SHALL BE ASTM A307 / GRADE I OR A325, AS PER PLAN REQUIREMENTS.
10. WELDS SHALL BE AS PER "AMERICAN WELDING SOCIETY" STANDARDS FOR STRUCTURAL STEEL APPLICATIONS.
WOOD STRUCTURAL NOTES:
1. TEMPORARY BRACING OF THE STRUCTURE DURING ERECTION REQUIRED FOR SAFE AND STABLE CONSTRUCTION, SHALL BE THE SOLE RESPONSIBILITY OF THE CONTRACTOR SO ENGAGED. TEMPORARY & PERMANENT BRACING OF ROOF TRUSSES SHALL BE AS PER THE STANDARD GUIDELINES OF THE "TRUSS PLATE INSTITUTE".
2. ALL TRUSSES SHALL BE DESIGNED BY A LICENSED PROFESSIONAL ENGINEER & SHALL BE SIGNED AND SEALED BY SAME. TRUSS DESIGN SHALL INCLUDE PLACEMENT PLANS, TRUSS DETAILS, TRUSS TO TRUSS CONNECTIONS & THE STANDARD SPECIFICATIONS & RECOMMENDATIONS OF INSTALLATION OF THE "TRUSS PLATE INSTITUTE".
3. WOOD STUDS IN EXTERIOR WALLS & INTERIOR BEARING WALLS SHALL BE NOT LESS THAN N-2 HEM-FIR OR BETTER.
4. CONNECTORS FOR WOOD FRAMING SHALL BE GALVANIZED METAL OR BLACK METAL AS MANUFACTURED OR AS CALLED FOR IN THE PLANS AND BE OF A DESIGN SUITABLE FOR THE LOADS AND USE INTENDED. REFER TO THE JOINT REINFORCEMENT SCHEDULE FOR PRINCIPLE CONNECTIONS.

These drawings, or instruments of service, are the sole property of the architect, and may not be used, copied or reproduced in whole or in part for use on or incorporation into any other job without specific and individual authorization by the architect.

REVISION:
Copyright 2005 N.P. Geller, Architect
DRAWN: DJR

Custom Designed Home for: DANIEL & MICHELLE STAGG
COLUMBIA COUNTY, FLORIDA
GENERAL NOTES

APP ARCHITECTURAL DRAFTING & DESIGN, INC.
Lake City, FL 32055 - 386.622.4670

NICHOLAS W. GELLES, ARCHITECT
738 NW Brown Rd., Lake City, FL 32055
(386) 622-4670

DATE: 20NOV2007
COMM:

SHEET: A.15
15 OF 15

AR0007005