



Lumber design values are in accordance with ANSI/TPI 1 section 6.3
 These truss designs rely on lumber values established by others.

RE: 3070916 - EVANS - FT WHITE SPEC

MiTek USA, Inc.
 6904 Parke East Blvd.
 Tampa, FL 33610-4115

Site Information:

Customer Info: Evans Bldg. Project Name: Ft. White Spec Hse Model: Custom
 Lot/Block: N/A Subdivision: N/A
 Address: TBD, TBD
 City: Columbia Cty State: FL

Name Address and License # of Structural Engineer of Record, if there is one, for the building.

Name: License #:
 Address: State:
 City: State:

General Truss Engineering Criteria & Design Loads (Individual Truss Design Drawings Show Special Loading Conditions):

Design Code: FBC2020/TPI2014 Design Program: MiTek 20/20 8.4
 Wind Code: ASCE 7-16 Wind Speed: 130 mph
 Roof Load: 37.0 psf Floor Load: N/A psf

This package includes 27 individual, Truss Design Drawings and 0 Additional Drawings.
 With my seal affixed to this sheet, I hereby certify that I am the Truss Design Engineer and this index sheet conforms to 61G15-31.003, section 5 of the Florida Board of Professional Engineers Rules.

No.	Seal#	Truss Name	Date	No.	Seal#	Truss Name	Date
1	T26813908	CJ01	2/11/22	23	T26813930	T11	2/11/22
2	T26813909	CJ03	2/11/22	24	T26813931	T12	2/11/22
3	T26813910	CJ03A	2/11/22	25	T26813932	T13	2/11/22
4	T26813911	CJ05	2/11/22	26	T26813933	T14	2/11/22
5	T26813912	CJ05A	2/11/22	27	T26813934	T14G	2/11/22
6	T26813913	EJ01	2/11/22				
7	T26813914	EJ02	2/11/22				
8	T26813915	EJ03	2/11/22				
9	T26813916	HJ08	2/11/22				
10	T26813917	HJ10	2/11/22				
11	T26813918	HJ10A	2/11/22				
12	T26813919	T01	2/11/22				
13	T26813920	T02	2/11/22				
14	T26813921	T03	2/11/22				
15	T26813922	T04	2/11/22				
16	T26813923	T05	2/11/22				
17	T26813924	T06	2/11/22				
18	T26813925	T06A	2/11/22				
19	T26813926	T07	2/11/22				
20	T26813927	T08	2/11/22				
21	T26813928	T09	2/11/22				
22	T26813929	T10	2/11/22				

The truss drawing(s) referenced above have been prepared by MiTek USA, Inc. under my direct supervision based on the parameters provided by Builders FirstSource-Lake City, FL.

Truss Design Engineer's Name: ORegan, Philip
 My license renewal date for the state of Florida is February 28, 2023.

IMPORTANT NOTE: The seal on these truss component designs is a certification that the engineer named is licensed in the jurisdiction(s) identified and that the designs comply with ANSI/TPI 1. These designs are based upon parameters shown (e.g., loads, supports, dimensions, shapes and design codes), which were given to MiTek or TRENCO. Any project specific information included is for MiTek's or TRENCO's customers file reference purpose only, and was not taken into account in the preparation of these designs. MiTek or TRENCO has not independently verified the applicability of the design parameters or the designs for any particular building. Before use, the building designer should verify applicability of design parameters and properly incorporate these designs into the overall building design per ANSI/TPI 1, Chapter 2.

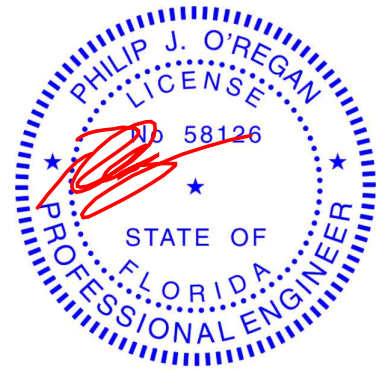

Philip J. O'Regan PE No.58126
 MiTek USA, Inc. FL Cert 6634
 6904 Parke East Blvd. Tampa FL 33610
 Date:

February 11, 2022

Job	Truss	Truss Type	Qty	Ply	EVANS - FT WHITE SPEC	T26813908
3070916	CJ01	Jack-Open	6	1		

Builders FirstSource (Lake City,FL),

Lake City, FL - 32055,

8.430 s Aug 16 2021 MiTek Industries, Inc. Thu Feb 10 16:08:47 2022 Page 1
ID:KlqOOpJ4Z1Cn3VD1sa2GzOzmc6D-VJe0ZzfwwKLR6Mh5dtwkiwp?kIH9grht_bH?rzmUmE

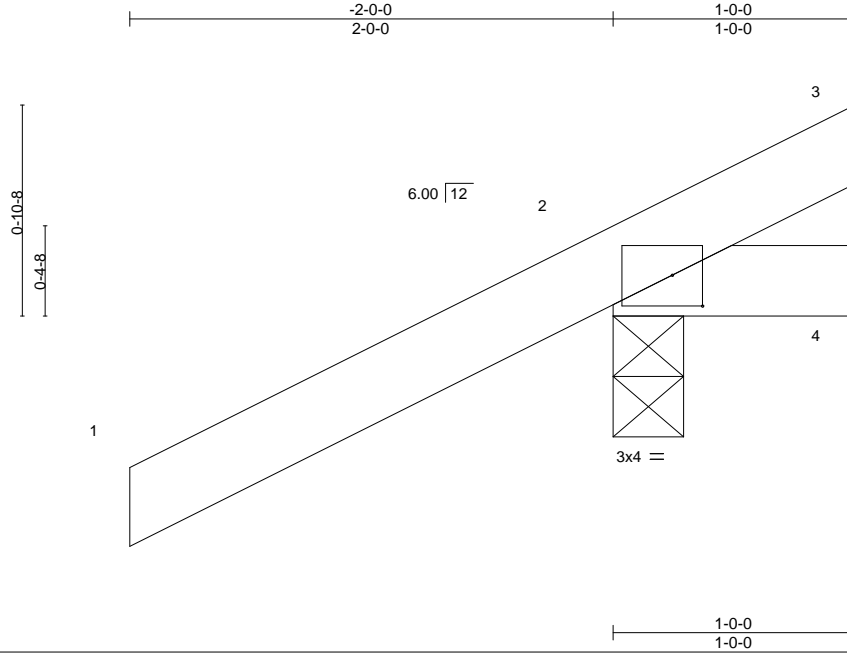

Scale = 1:9.5

Plate Offsets (X,Y)-- [2:0-1-8,0-1-9]

LOADING (psf)	SPACING-	2-0-0	CSI.	DEFL.	in (loc)	l/defl	L/d	PLATES	GRIP
TCLL 20.0	Plate Grip DOL	1.25	TC 0.25	Vert(LL)	0.00	7	>999	MT20	244/190
TCDL 7.0	Lumber DOL	1.25	BC 0.05	Vert(CT)	0.00	7	>999		
BCLL 0.0 *	Rep Stress Incr	YES	WB 0.00	Horz(CT)	0.00	2	n/a		
BCDL 10.0	Code	FBC2020/TPI2014	Matrix-MP					Weight: 7 lb	FT = 20%

LUMBER-

TOP CHORD 2x4 SP No.2
BOT CHORD 2x4 SP No.2

BRACING-

TOP CHORD Structural wood sheathing directly applied or 1-0-0 oc purlins.
BOT CHORD Rigid ceiling directly applied or 10-0-0 oc bracing.

REACTIONS.

(size) 3=Mechanical, 2=0-3-8, 4=Mechanical
Max Horz 2=46(LC 12)
Max Uplift 3=-27(LC 1), 2=-102(LC 12), 4=-46(LC 1)
Max Grav 3=16(LC 16), 2=254(LC 1), 4=29(LC 16)

FORCES. (lb) - Max. Comp./Max. Ten. - All forces 250 (lb) or less except when shown.

NOTES-

- 1) Wind: ASCE 7-16; Vult=130mph (3-second gust) Vasd=101mph; TCDL=4.2psf; BCDL=3.0psf; h=20ft; Cat. II; Exp B; Encl., GCpi=0.18; MWFRS (envelope) gable end zone and C-C Exterior(2E) zone; porch left and right exposed;C-C for members and forces & MWFRS for reactions shown; Lumber DOL=1.60 plate grip DOL=1.60
- 2) Building Designer / Project engineer responsible for verifying applied roof live load shown covers rain loading requirements specific to the use of this truss component.
- 3) This truss has been designed for a 10.0 psf bottom chord live load nonconcurrent with any other live loads.
- 4) * This truss has been designed for a live load of 20.0psf on the bottom chord in all areas where a rectangle 3-6-0 tall by 2-0-0 wide will fit between the bottom chord and any other members.
- 5) Refer to girder(s) for truss to truss connections.
- 6) Provide mechanical connection (by others) of truss to bearing plate capable of withstanding 27 lb uplift at joint 3, 102 lb uplift at joint 2 and 46 lb uplift at joint 4.

February 11,2022

WARNING - Verify design parameters and READ NOTES ON THIS AND INCLUDED MITEK REFERENCE PAGE MII-7473 rev. 5/19/2020 BEFORE USE.

Design valid for use only with MiTek® connectors. This design is based only upon parameters shown, and is for an individual building component, not a truss system. Before use, the building designer must verify the applicability of design parameters and properly incorporate this design into the overall building design. Bracing indicated is to prevent buckling of individual truss web and/or chord members only. Additional temporary and permanent bracing is always required for stability and to prevent collapse with possible personal injury and property damage. For general guidance regarding the fabrication, storage, delivery, erection and bracing of trusses and truss systems, see

ANSI/TPI1 Quality Criteria, DSB-89 and BCSI Building Component

Safety Information available from Truss Plate Institute, 2670 Crain Highway, Suite 203 Waldorf, MD 20601



6904 Parke East Blvd.
Tampa, FL 36610

Job	Truss	Truss Type	Qty	Ply	EVANS - FT WHITE SPEC	T26813909
3070916	CJ03	Jack-Open	4	1		

Builders FirstSource (Lake City,FL),

Lake City, FL - 32055,

8.430 s Aug 16 2021 MiTek Industries, Inc. Thu Feb 10 16:08:48 2022 Page 1

ID:KlqOOpJ4Z1Cn3VD1sa2GzOzmc6D-zxt0Du_HhETC3GwueKO9HvS_l8d_u74q6eKqYHzmUmD

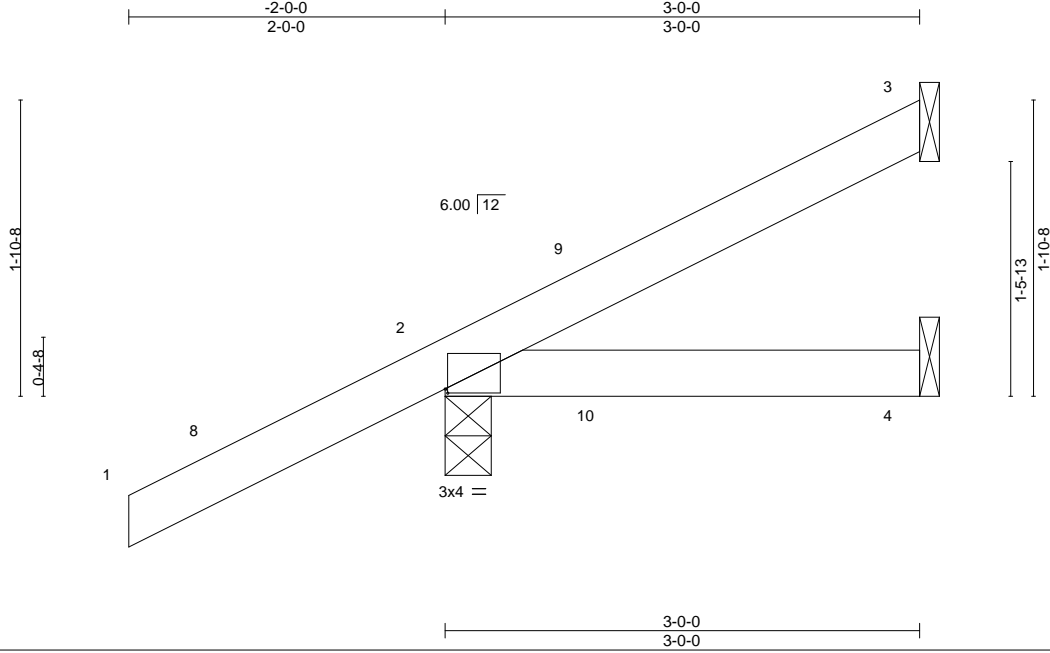

Plate Offsets (X,Y)--	[2:0-0-3,0-0-5]
-----------------------	-----------------

LOADING (psf)	SPACING-	2-0-0	CSI.	DEFL.	in (loc)	l/defl	L/d	PLATES	GRIP	
TCLL 20.0	Plate Grip DOL	1.25	TC 0.25	Vert(LL)	0.01	4-7	>999	240	MT20	244/190
TCDL 7.0	Lumber DOL	1.25	BC 0.09	Vert(CT)	-0.01	4-7	>999	180		
BCLL 0.0 *	Rep Stress Incr	YES	WB 0.00	Horz(CT)	-0.00	3	n/a	n/a		
BCDL 10.0	Code	FBC2020/TPI2014	Matrix-MP							
									Weight: 13 lb	FT = 20%

LUMBER-	BRACING-
TOP CHORD 2x4 SP No.2	TOP CHORD Structural wood sheathing directly applied or 3-0-0 oc purlins.
BOT CHORD 2x4 SP No.2	BOT CHORD Rigid ceiling directly applied or 10-0-0 oc bracing.

REACTIONS. (size) 3=Mechanical, 2=0-3-8, 4=Mechanical
 Max Horz 2=80(LC 12)
 Max Uplift 3=-31(LC 12), 2=-76(LC 12), 4=-14(LC 9)
 Max Grav 3=52(LC 1), 2=253(LC 1), 4=48(LC 3)

FORCES. (lb) - Max. Comp./Max. Ten. - All forces 250 (lb) or less except when shown.

- NOTES-**
- 1) Wind: ASCE 7-16; Vult=130mph (3-second gust) Vasd=101mph; TCDL=4.2psf; BCDL=3.0psf; h=20ft; Cat. II; Exp B; Encl., GCpi=0.18; MWFRS (envelope) gable end zone and C-C Exterior(2E) -2-0-0 to 1-0-0, Interior(1) 1-0-0 to 2-11-4 zone; porch left and right exposed;C-C for members and forces & MWFRS for reactions shown; Lumber DOL=1.60 plate grip DOL=1.60
 - 2) Building Designer / Project engineer responsible for verifying applied roof live load shown covers rain loading requirements specific to the use of this truss component.
 - 3) This truss has been designed for a 10.0 psf bottom chord live load nonconcurrent with any other live loads.
 - 4) * This truss has been designed for a live load of 20.0psf on the bottom chord in all areas where a rectangle 3-6-0 tall by 2-0-0 wide will fit between the bottom chord and any other members.
 - 5) Refer to girder(s) for truss to truss connections.
 - 6) Provide mechanical connection (by others) of truss to bearing plate capable of withstanding 31 lb uplift at joint 3, 76 lb uplift at joint 2 and 14 lb uplift at joint 4.

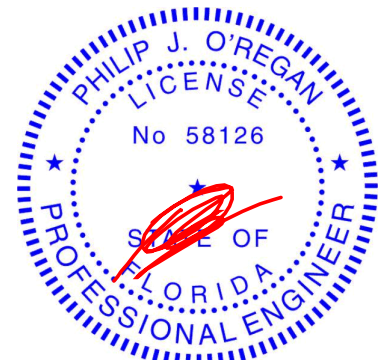

Philip J. O'Regan PE No.58126
 MiTek USA, Inc. FL Cert 6634
 6904 Parke East Blvd. Tampa FL 33610
 Date:

February 11,2022

WARNING - Verify design parameters and READ NOTES ON THIS AND INCLUDED MITEK REFERENCE PAGE MII-7473 rev. 5/19/2020 BEFORE USE.

Design valid for use only with MiTek® connectors. This design is based only upon parameters shown, and is for an individual building component, not a truss system. Before use, the building designer must verify the applicability of design parameters and properly incorporate this design into the overall building design. Bracing indicated is to prevent buckling of individual truss web and/or chord members only. Additional temporary and permanent bracing is always required for stability and to prevent collapse with possible personal injury and property damage. For general guidance regarding the fabrication, storage, delivery, erection and bracing of trusses and truss systems, see

ANSI/TPI1 Quality Criteria, DSB-89 and BCSI Building Component

Safety Information available from Truss Plate Institute, 2670 Crain Highway, Suite 203 Waldorf, MD 20601



6904 Parke East Blvd.
 Tampa, FL 36610

Job	Truss	Truss Type	Qty	Ply	EVANS - FT WHITE SPEC	T26813910
3070916	CJ03A	Jack-Open	2	1	Job Reference (optional)	

Builders FirstSource (Lake City,FL),

Lake City, FL - 32055,

8.430 s Aug 16 2021 MiTek Industries, Inc. Thu Feb 10 16:08:49 2022 Page 1

ID:KlqOOpJ4Z1Cn3VD1sa2GzOzmc6D-R7QORE?vSXb3hQV4C2vOq7?9VXzFdaK_KI4N4jzmUmC

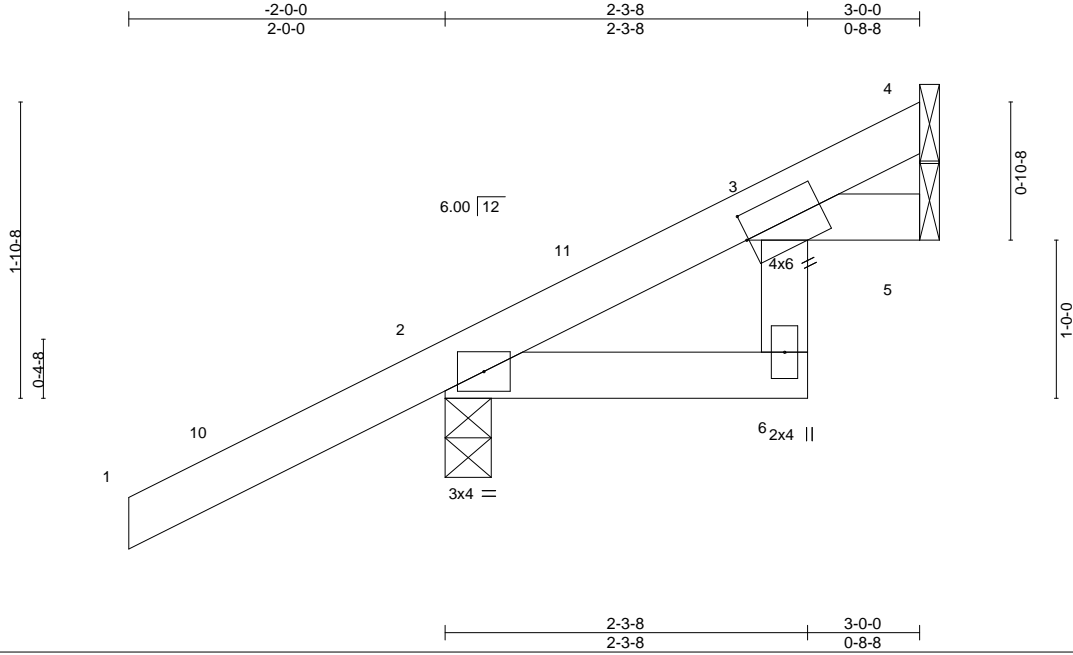

Scale = 1:14.6

Plate Offsets (X,Y)-- [3:0-0,3:0-1-15]

LOADING (psf)	SPACING-		CSI.	DEFL.	in	(loc)	l/defl	L/d	PLATES	GRIP
TCLL 20.0	Plate Grip DOL	2-0-0	TC 0.25	Vert(LL)	-0.00	6	>999	240	MT20	244/190
TCDL 7.0	Lumber DOL	1.25	BC 0.08	Vert(CT)	-0.01	6	>999	180		
BCLL 0.0 *	Rep Stress Incr	YES	WB 0.00	Horz(CT)	0.00	5	n/a	n/a		
BCDL 10.0	Code	FBC2020/TPI2014	Matrix-MR						Weight: 15 lb	FT = 20%

LUMBER-

TOP CHORD 2x4 SP No.2
 BOT CHORD 2x4 SP No.2 *Except*
 3-6: 2x4 SP No.3

BRACING-

TOP CHORD Structural wood sheathing directly applied or 3-0-0 oc purlins.
 BOT CHORD Rigid ceiling directly applied or 6-0-0 oc bracing.

REACTIONS.

(size) 4=Mechanical, 2=0-3-8, 5=Mechanical
 Max Horz 2=80(LC 12)
 Max Uplift 4=-18(LC 12), 2=-76(LC 12), 5=-7(LC 12)
 Max Grav 4=40(LC 1), 2=254(LC 1), 5=40(LC 3)

FORCES. (lb) - Max. Comp./Max. Ten. - All forces 250 (lb) or less except when shown.

NOTES-

- 1) Wind: ASCE 7-16; Vult=130mph (3-second gust) Vasd=101mph; TCDL=4.2psf; BCDL=3.0psf; h=20ft; Cat. II; Exp B; Encl., GCpi=0.18; MWFRS (envelope) gable end zone and C-C Exterior(2E) -2-0-0 to 1-0-0, Interior(1) 1-0-0 to 2-11-4 zone;C-C for members and forces & MWFRS for reactions shown; Lumber DOL=1.60 plate grip DOL=1.60
- 2) Building Designer / Project engineer responsible for verifying applied roof live load shown covers rain loading requirements specific to the use of this truss component.
- 3) This truss has been designed for a 10.0 psf bottom chord live load nonconcurrent with any other live loads.
- 4) * This truss has been designed for a live load of 20.0psf on the bottom chord in all areas where a rectangle 3-6-0 tall by 2-0-0 wide will fit between the bottom chord and any other members.
- 5) Refer to girder(s) for truss to truss connections.
- 6) Provide mechanical connection (by others) of truss to bearing plate capable of withstanding 18 lb uplift at joint 4, 76 lb uplift at joint 2 and 7 lb uplift at joint 5.

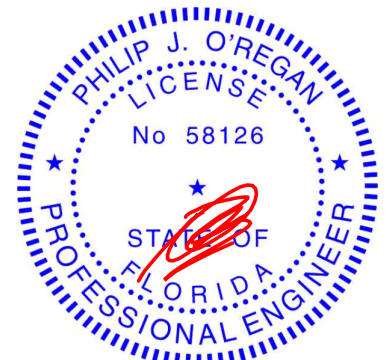

Philip J. O'Regan PE No.58126
 MiTek USA, Inc. FL Cert 6634
 6904 Parke East Blvd. Tampa FL 33610
 Date:

February 11,2022

WARNING - Verify design parameters and READ NOTES ON THIS AND INCLUDED MITEK REFERENCE PAGE MII-7473 rev. 5/19/2020 BEFORE USE.

Design valid for use only with MiTek® connectors. This design is based only upon parameters shown, and is for an individual building component, not a truss system. Before use, the building designer must verify the applicability of design parameters and properly incorporate this design into the overall building design. Bracing indicated is to prevent buckling of individual truss web and/or chord members only. Additional temporary and permanent bracing is always required for stability and to prevent collapse with possible personal injury and property damage. For general guidance regarding the fabrication, storage, delivery, erection and bracing of trusses and truss systems, see

ANSI/TPI1 Quality Criteria, DSB-89 and BCSI Building Component

Safety Information available from Truss Plate Institute, 2670 Crain Highway, Suite 203 Waldorf, MD 20601



6904 Parke East Blvd.
 Tampa, FL 36610

Job	Truss	Truss Type	Qty	Ply	EVANS - FT WHITE SPEC	T26813911
3070916	CJ05	Jack-Open	4	1	Job Reference (optional)	

Builders FirstSource (Lake City,FL),

Lake City, FL - 32055,

8.430 s Aug 16 2021 MiTek Industries, Inc. Thu Feb 10 16:08:51 2022 Page 1

ID:KlqOOpJ4Z1Cn3VD1sa2GzOzmc6D-NWY9sw09_9rnwfkTKTysvY4UxLdSSUqHobZU8czmUma

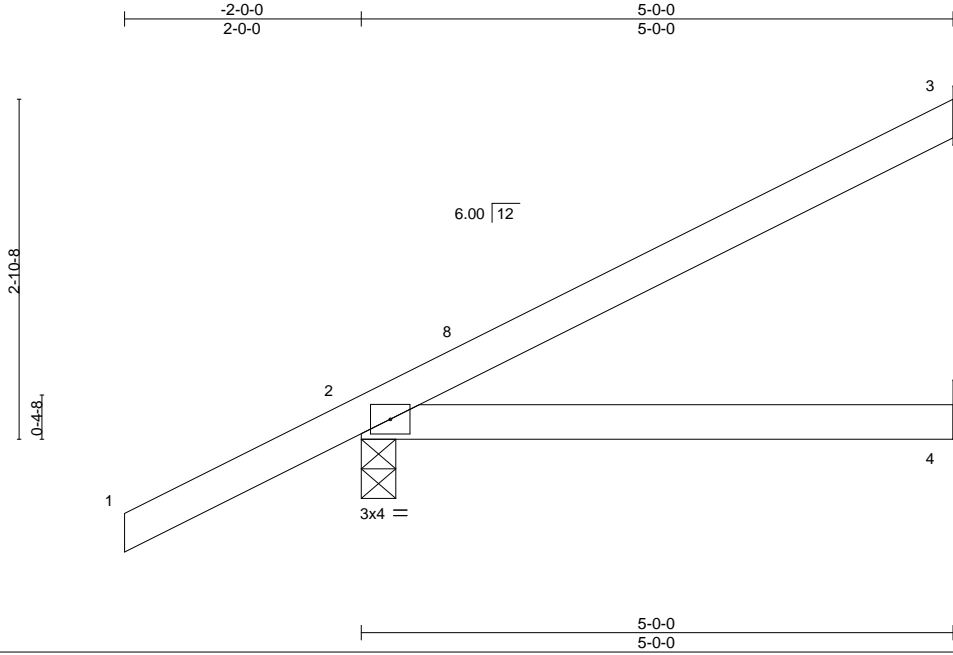

Scale = 1:19.5

LOADING (psf)	SPACING-	CSI.	DEFL.	in (loc)	l/defl	L/d	PLATES	GRIP
TCLL 20.0	2-0-0	TC 0.26	Vert(LL)	0.03	4-7	>999	MT20	244/190
TCDL 7.0	Lumber DOL 1.25	BC 0.23	Vert(CT)	-0.05	4-7	>999		
BCLL 0.0 *	Rep Stress Incr YES	WB 0.00	Horz(CT)	0.00	3	n/a		
BCDL 10.0	Code FBC2020/TPI2014	Matrix-MP					Weight: 19 lb	FT = 20%

LUMBER-

TOP CHORD 2x4 SP No.2
BOT CHORD 2x4 SP No.2

BRACING-

TOP CHORD Structural wood sheathing directly applied or 5-0-0 oc purlins.
BOT CHORD Rigid ceiling directly applied or 10-0-0 oc bracing.

REACTIONS.

(size) 3=Mechanical, 2=0-3-8, 4=Mechanical
Max Horz 2=114(LC 12)
Max Uplift 3=64(LC 12), 2=80(LC 12)
Max Grav 3=108(LC 1), 2=313(LC 1), 4=87(LC 3)

FORCES. (lb) - Max. Comp./Max. Ten. - All forces 250 (lb) or less except when shown.

NOTES-

- 1) Wind: ASCE 7-16; Vult=130mph (3-second gust) Vasd=101mph; TCDL=4.2psf; BCDL=3.0psf; h=20ft; Cat. II; Exp B; Encl., GCpi=0.18; MWFRS (envelope) gable end zone and C-C Exterior(2E) -2-0-0 to 1-0-0, Interior(1) 1-0-0 to 4-11-4 zone; porch right exposed; C-C for members and forces & MWFRS for reactions shown; Lumber DOL=1.60 plate grip DOL=1.60
- 2) Building Designer / Project engineer responsible for verifying applied roof live load shown covers rain loading requirements specific to the use of this truss component.
- 3) This truss has been designed for a 10.0 psf bottom chord live load nonconcurrent with any other live loads.
- 4) * This truss has been designed for a live load of 20.0psf on the bottom chord in all areas where a rectangle 3-6-0 tall by 2-0-0 wide will fit between the bottom chord and any other members.
- 5) Refer to girder(s) for truss to truss connections.
- 6) Provide mechanical connection (by others) of truss to bearing plate capable of withstanding 64 lb uplift at joint 3 and 80 lb uplift at joint 2.

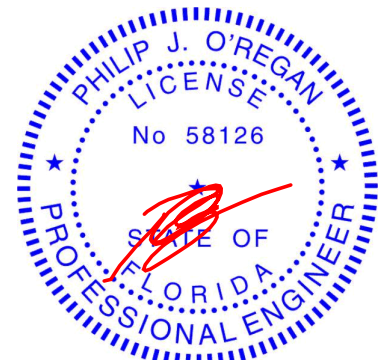

Philip J. O'Regan PE No.58126
MiTek USA, Inc. FL Cert 6634
6904 Parke East Blvd. Tampa FL 33610
Date:

February 11, 2022

WARNING - Verify design parameters and READ NOTES ON THIS AND INCLUDED MITEK REFERENCE PAGE MII-7473 rev. 5/19/2020 BEFORE USE.

Design valid for use only with MiTek® connectors. This design is based only upon parameters shown, and is for an individual building component, not a truss system. Before use, the building designer must verify the applicability of design parameters and properly incorporate this design into the overall building design. Bracing indicated is to prevent buckling of individual truss web and/or chord members only. Additional temporary and permanent bracing is always required for stability and to prevent collapse with possible personal injury and property damage. For general guidance regarding the fabrication, storage, delivery, erection and bracing of trusses and truss systems, see

ANSI/TPI1 Quality Criteria, DSB-89 and BCSI Building Component

Safety Information available from Truss Plate Institute, 2670 Crain Highway, Suite 203 Waldorf, MD 20601



6904 Parke East Blvd.
Tampa, FL 36610

Job	Truss	Truss Type	Qty	Ply	EVANS - FT WHITE SPEC	T26813912
3070916	CJ05A	Jack-Open	2	1		

Builders FirstSource (Lake City,FL),

Lake City, FL - 32055,

8.430 s Aug 16 2021 MiTek Industries, Inc. Thu Feb 10 16:08:52 2022 Page 1
ID:KlqOOpJ4Z1Cn3VD1sa2GzOzmc6D-si6X3G1nlSzdYtEftAT5Rldeflydqw4Q1F1h2zmUm9

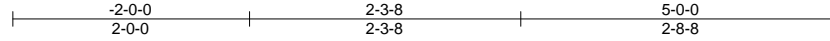

Scale = 1:19.5

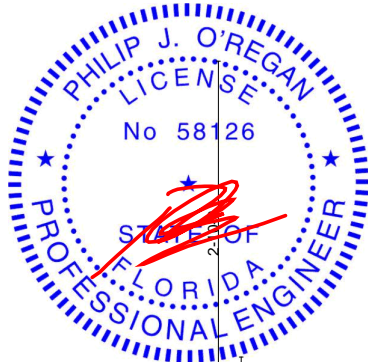

Philip J. O'Regan PE No. 58126
MiTek USA, Inc. FL Cert 6834
6904 Parke East Blvd. Tampa FL 33610
Date:

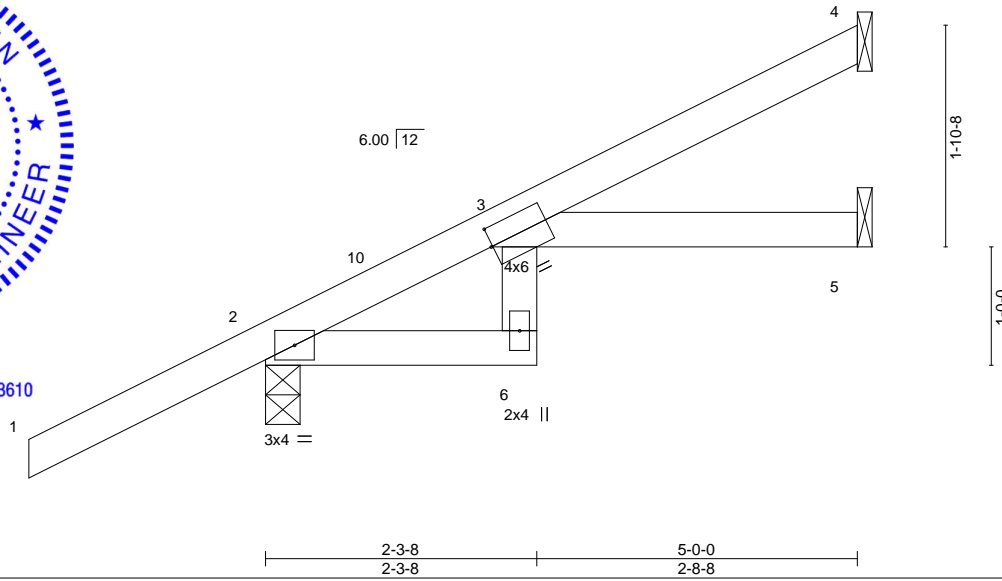

Plate Offsets (X,Y)-- [3:0-0,3:0-1-15]

LOADING (psf)	SPACING-	CSI.	DEFL.	PLATES	GRIP
TCLL 20.0	Plate Grip DOL 1.25	TC 0.32	Vert(LL) 0.05 6 >999 240	MT20	244/190
TCDL 7.0	Lumber DOL 1.25	BC 0.23	Vert(CT) -0.06 6 >937 180		
BCLL 0.0 *	Rep Stress Incr YES	WB 0.00	Horz(CT) 0.04 5 n/a n/a		
BCDL 10.0	Code FBC2020/TPI2014	Matrix-MR		Weight: 21 lb	FT = 20%

LUMBER-

TOP CHORD 2x4 SP No.2
BOT CHORD 2x4 SP No.2 *Except*
3-6: 2x4 SP No.3

BRACING-

TOP CHORD Structural wood sheathing directly applied or 5-0-0 oc purlins.
BOT CHORD Rigid ceiling directly applied or 6-0-0 oc bracing.

REACTIONS.

(size) 4=Mechanical, 2=0-3-8, 5=Mechanical
Max Horz 2=114(LC 12)
Max Uplift 4=-51(LC 12), 2=-80(LC 12), 5=-10(LC 12)
Max Grav 4=96(LC 1), 2=313(LC 1), 5=80(LC 3)

FORCES. (lb) - Max. Comp./Max. Ten. - All forces 250 (lb) or less except when shown.

NOTES-

- 1) Wind: ASCE 7-16; Vult=130mph (3-second gust) Vasd=101mph; TCDL=4.2psf; BCDL=3.0psf; h=20ft; Cat. II; Exp B; Encl., GCpi=0.18; MWFRS (envelope) gable end zone and C-C Exterior(2E) -2-0-0 to 1-0-0, Interior(1) 1-0-0 to 4-11-4 zone;C-C for members and forces & MWFRS for reactions shown; Lumber DOL=1.60 plate grip DOL=1.60
- 2) Building Designer / Project engineer responsible for verifying applied roof live load shown covers rain loading requirements specific to the use of this truss component.
- 3) This truss has been designed for a 10.0 psf bottom chord live load nonconcurrent with any other live loads.
- 4) * This truss has been designed for a live load of 20.0psf on the bottom chord in all areas where a rectangle 3-6-0 tall by 2-0-0 wide will fit between the bottom chord and any other members.
- 5) Refer to girder(s) for truss to truss connections.
- 6) Provide mechanical connection (by others) of truss to bearing plate capable of withstanding 51 lb uplift at joint 4, 80 lb uplift at joint 2 and 10 lb uplift at joint 5.

February 11,2022

WARNING - Verify design parameters and READ NOTES ON THIS AND INCLUDED MITEK REFERENCE PAGE MII-7473 rev. 5/19/2020 BEFORE USE.

Design valid for use only with MiTek® connectors. This design is based only upon parameters shown, and is for an individual building component, not a truss system. Before use, the building designer must verify the applicability of design parameters and properly incorporate this design into the overall building design. Bracing indicated is to prevent buckling of individual truss web and/or chord members only. Additional temporary and permanent bracing is always required for stability and to prevent collapse with possible personal injury and property damage. For general guidance regarding the fabrication, storage, delivery, erection and bracing of trusses and truss systems, see

ANSI/TPI1 Quality Criteria, DSB-89 and BCSI Building Component

Safety Information available from Truss Plate Institute, 2670 Crain Highway, Suite 203 Waldorf, MD 20601



6904 Parke East Blvd.
Tampa, FL 36610

Job	Truss	Truss Type	Qty	Ply	EVANS - FT WHITE SPEC	T26813913
3070916	EJ01	Jack-Partial	7	1		

Builders FirstSource (Lake City,FL),

Lake City, FL - 32055,

8.430 s Aug 16 2021 MiTek Industries, Inc. Thu Feb 10 16:08:53 2022 Page 1

ID:KlqOOOpJ4Z1Cn3VD1sa2GzOzmc6D-KugvGc2QWm5U91prRu_K_zAl19EcZnKZFv2bDVzmUm8

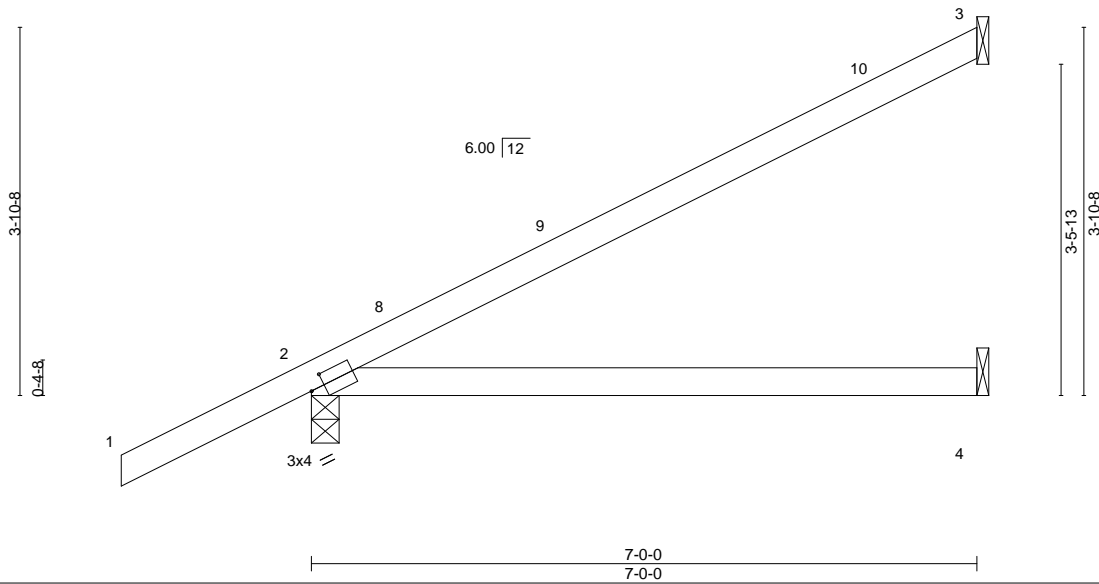

Plate Offsets (X,Y)-- [2:0-1-13,0-1-8]

LOADING (psf)	SPACING-	CSI.	DEFL.	in (loc)	l/defl	L/d	PLATES	GRIP
TCLL 20.0	Plate Grip DOL 1.25	TC 0.60	Vert(LL) 0.10	4-7	>876	240	MT20	244/190
TCDL 7.0	Lumber DOL 1.25	BC 0.51	Vert(CT) -0.21	4-7	>393	180		
BCLL 0.0 *	Rep Stress Incr YES	WB 0.00	Horz(CT) 0.01	2	n/a	n/a		
BCDL 10.0	Code FBC2020/TPI2014	Matrix-MS					Weight: 26 lb	FT = 20%

LUMBER-

TOP CHORD 2x4 SP No.2
BOT CHORD 2x4 SP No.2

BRACING-

TOP CHORD Structural wood sheathing directly applied or 6-0-0 oc purlins.
BOT CHORD Rigid ceiling directly applied or 10-0-0 oc bracing.

REACTIONS.

(size) 3=Mechanical, 2=0-3-8, 4=Mechanical
Max Horz 2=144(LC 12)
Max Uplift 3=84(LC 12), 2=90(LC 12)
Max Grav 3=160(LC 1), 2=380(LC 1), 4=125(LC 3)

FORCES. (lb) - Max. Comp./Max. Ten. - All forces 250 (lb) or less except when shown.

NOTES-

- 1) Wind: ASCE 7-16; Vult=130mph (3-second gust) Vasd=101mph; TCDL=4.2psf; BCDL=3.0psf; h=20ft; Cat. II; Exp B; Encl., GCpi=0.18; MWFRS (envelope) gable end zone and C-C Exterior(2E) -2-0-0 to 1-0-0, Interior(1) 1-0-0 to 6-11-4 zone;C-C for members and forces & MWFRS for reactions shown; Lumber DOL=1.60 plate grip DOL=1.60
- 2) Building Designer / Project engineer responsible for verifying applied roof live load shown covers rain loading requirements specific to the use of this truss component.
- 3) This truss has been designed for a 10.0 psf bottom chord live load nonconcurrent with any other live loads.
- 4) * This truss has been designed for a live load of 20.0psf on the bottom chord in all areas where a rectangle 3-6-0 tall by 2-0-0 wide will fit between the bottom chord and any other members.
- 5) Refer to girder(s) for truss to truss connections.
- 6) Provide mechanical connection (by others) of truss to bearing plate capable of withstanding 84 lb uplift at joint 3 and 90 lb uplift at joint 2.

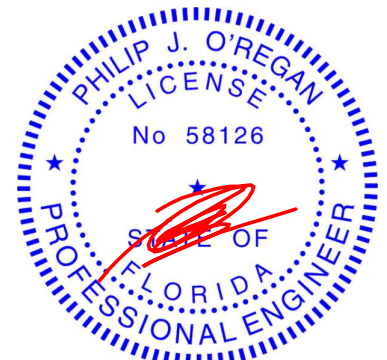

Philip J. O'Regan PE No.58126
MiTek USA, Inc. FL Cert 6634
6904 Parke East Blvd. Tampa FL 33610
Date:

February 11,2022

WARNING - Verify design parameters and READ NOTES ON THIS AND INCLUDED MITEK REFERENCE PAGE MII-7473 rev. 5/19/2020 BEFORE USE.

Design valid for use only with MiTek® connectors. This design is based only upon parameters shown, and is for an individual building component, not a truss system. Before use, the building designer must verify the applicability of design parameters and properly incorporate this design into the overall building design. Bracing indicated is to prevent buckling of individual truss web and/or chord members only. Additional temporary and permanent bracing is always required for stability and to prevent collapse with possible personal injury and property damage. For general guidance regarding the fabrication, storage, delivery, erection and bracing of trusses and truss systems, see

ANSI/TPI1 Quality Criteria, DSB-89 and BCSI Building Component

Safety Information available from Truss Plate Institute, 2670 Crain Highway, Suite 203 Waldorf, MD 20601



6904 Parke East Blvd.
Tampa, FL 36610

Job	Truss	Truss Type	Qty	Ply	EVANS - FT WHITE SPEC	T26813914
3070916	EJ02	Jack-Partial	3	1	Job Reference (optional)	

Builders FirstSource (Lake City,FL),

Lake City, FL - 32055,

8.430 s Aug 16 2021 MiTek Industries, Inc. Thu Feb 10 16:08:53 2022 Page 1

ID:KlqOOpJ4Z1Cn3VD1sa2GzOzmc6D-KugvGc2QWm5U91prRu_K_zAlr9D9ZNKZFv2bDVzmUm8

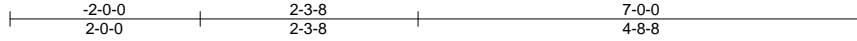

Scale: 1/2"=1'

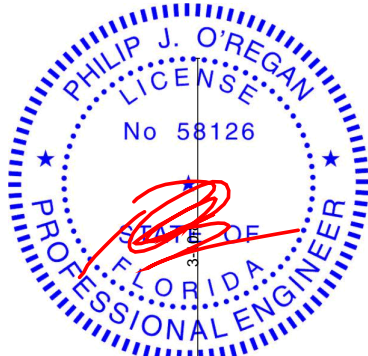

Philip J. O'Regan PE No.58126
MiTek USA, Inc. FL Cert#6634
6904 Parke East Blvd. Tampa FL 33610
Date:

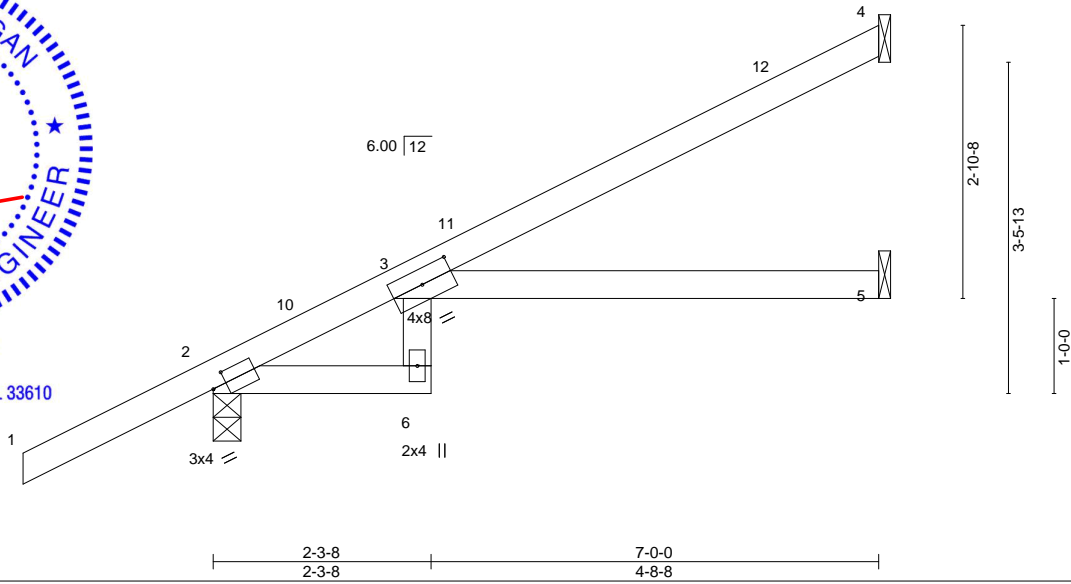

Plate Offsets (X,Y)-- [2:0-1-13,0-1-8], [3:0-4-0,0-1-15]

LOADING (psf)	SPACING-	CSI.	DEFL.	PLATES	GRIP
TCLL 20.0	Plate Grip DOL 1.25	TC 0.61	in (loc) l/defl L/d	MT20	244/190
TCDL 7.0	Lumber DOL 1.25	BC 0.53	Vert(LL) 0.15 3-5 >568 240		
BCLL 0.0 *	Rep Stress Incr YES	WB 0.00	Vert(CT) -0.24 3-5 >340 180		
BCDL 10.0	Code FBC2020/TPI2014	Matrix-MR	Horz(CT) 0.12 5 n/a n/a	Weight: 27 lb	FT = 20%

LUMBER-

TOP CHORD 2x4 SP No.2
BOT CHORD 2x4 SP No.2 *Except*
3-6: 2x4 SP No.3

BRACING-

TOP CHORD Structural wood sheathing directly applied or 6-0-0 oc purlins.
BOT CHORD Rigid ceiling directly applied or 6-0-0 oc bracing.

REACTIONS.

(size) 4=Mechanical, 2=0-3-8, 5=Mechanical
Max Horz 2=144(LC 12)
Max Uplift 4=-71(LC 12), 2=-90(LC 12), 5=-10(LC 12)
Max Grav 4=148(LC 1), 2=380(LC 1), 5=118(LC 3)

FORCES. (lb) - Max. Comp./Max. Ten. - All forces 250 (lb) or less except when shown.

NOTES-

- 1) Wind: ASCE 7-16; Vult=130mph (3-second gust) Vasd=101mph; TC DL=4.2psf; BCDL=3.0psf; h=20ft; Cat. II; Exp B; Encl., GCpi=0.18; MWFRS (envelope) gable end zone and C-C Exterior(2E) -2-0-0 to 1-0-0, Interior(1) 1-0-0 to 6-11-4 zone;C-C for members and forces & MWFRS for reactions shown; Lumber DOL=1.60 plate grip DOL=1.60
- 2) Building Designer / Project engineer responsible for verifying applied roof live load shown covers rain loading requirements specific to the use of this truss component.
- 3) This truss has been designed for a 10.0 psf bottom chord live load nonconcurrent with any other live loads.
- 4) * This truss has been designed for a live load of 20.0psf on the bottom chord in all areas where a rectangle 3-6-0 tall by 2-0-0 wide will fit between the bottom chord and any other members.
- 5) Refer to girder(s) for truss to truss connections.
- 6) Provide mechanical connection (by others) of truss to bearing plate capable of withstanding 71 lb uplift at joint 4, 90 lb uplift at joint 2 and 10 lb uplift at joint 5.

February 11,2022

WARNING - Verify design parameters and READ NOTES ON THIS AND INCLUDED MITEK REFERENCE PAGE MII-7473 rev. 5/19/2020 BEFORE USE.

Design valid for use only with MiTek® connectors. This design is based only upon parameters shown, and is for an individual building component, not a truss system. Before use, the building designer must verify the applicability of design parameters and properly incorporate this design into the overall building design. Bracing indicated is to prevent buckling of individual truss web and/or chord members only. Additional temporary and permanent bracing is always required for stability and to prevent collapse with possible personal injury and property damage. For general guidance regarding the fabrication, storage, delivery, erection and bracing of trusses and truss systems, see

ANSI/TPI1 Quality Criteria, DSB-89 and BCSI Building Component

Safety Information available from Truss Plate Institute, 2670 Crain Highway, Suite 203 Waldorf, MD 20601



6904 Parke East Blvd.
Tampa, FL 36610

Job	Truss	Truss Type	Qty	Ply	EVANS - FT WHITE SPEC	T26813915
3070916	EJ03	Jack-Partial	6	1		

Builders FirstSource (Lake City,FL),

Lake City, FL - 32055,

8.430 s Aug 16 2021 MiTek Industries, Inc. Thu Feb 10 16:08:54 2022 Page 1

ID:KlqOOpJ4Z1Cn3VD1sa2GzOzmc6D-o5EHUy32H4DLnBO2?vZXAi0FYdclp9JUzn8lxzmUm7

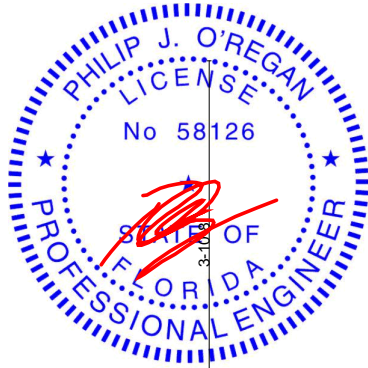
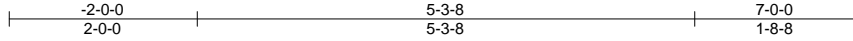

Philip J. O'Regan PE No.58126
MiTek USA, Inc. FL Cert #634
6904 Parke East Blvd. Tampa FL 33610
Date:

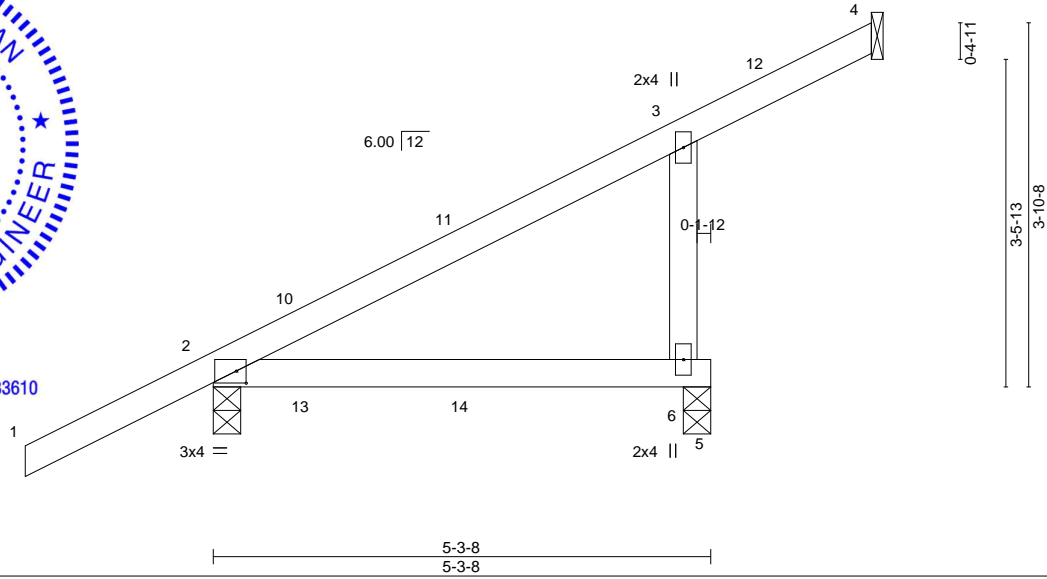

Scale = 1:24.5

Plate Offsets (X,Y)-- [2:0-1-4,0-1-9]

LOADING (psf)	SPACING-		CSI.	DEFL.	in	(loc)	I/defl	L/d	PLATES	GRIP
TCLL 20.0	Plate Grip DOL 1.25	2-0-0	TC 0.25	Vert(LL) 0.06	6-9	>999	240		MT20	244/190
TCDL 7.0	Lumber DOL 1.25		BC 0.26	Vert(CT) -0.05	6-9	>999	180			
BCLL 0.0 *	Rep Stress Incr YES		WB 0.09	Horz(CT) -0.00	4	n/a	n/a			
BCDL 10.0	Code FBC2020/TPI2014		Matrix-MP						Weight: 27 lb	FT = 20%

LUMBER-

TOP CHORD 2x4 SP No.2
BOT CHORD 2x4 SP No.2
WEBS 2x4 SP No.3

BRACING-

TOP CHORD Structural wood sheathing directly applied or 5-3-8 oc purlins.
BOT CHORD Rigid ceiling directly applied or 10-0-0 oc bracing.

REACTIONS.

(size) 4=Mechanical, 2=0-3-8, 6=0-3-8
Max Horz 2=144(LC 12)
Max Uplift 4=-12(LC 3), 2=-56(LC 12), 6=-126(LC 12)
Max Grav 4=6(LC 19), 2=296(LC 1), 6=289(LC 1)

FORCES. (lb) - Max. Comp./Max. Ten. - All forces 250 (lb) or less except when shown.

WEBS 3-6=-235/309

NOTES-

- 1) Wind: ASCE 7-16; Vult=130mph (3-second gust) Vasd=101mph; TCDL=4.2psf; BCDL=3.0psf; h=20ft; Cat. II; Exp B; Encl., GCpi=0.18; MWFRS (envelope) gable end zone and C-C Exterior(2E) -2-0-0 to 1-0-0, Interior(1) 1-0-0 to 6-11-4 zone; porch left exposed; C-C for members and forces & MWFRS for reactions shown; Lumber DOL=1.60 plate grip DOL=1.60
- 2) Building Designer / Project engineer responsible for verifying applied roof live load shown covers rain loading requirements specific to the use of this truss component.
- 3) This truss has been designed for a 10.0 psf bottom chord live load nonconcurrent with any other live loads.
- 4) * This truss has been designed for a live load of 20.0psf on the bottom chord in all areas where a rectangle 3-6-0 tall by 2-0-0 wide will fit between the bottom chord and any other members.
- 5) Refer to girder(s) for truss to truss connections.
- 6) Provide mechanical connection (by others) of truss to bearing plate capable of withstanding 12 lb uplift at joint 4, 56 lb uplift at joint 2 and 126 lb uplift at joint 6.

February 11, 2022

WARNING - Verify design parameters and READ NOTES ON THIS AND INCLUDED MITEK REFERENCE PAGE MII-7473 rev. 5/19/2020 BEFORE USE.

Design valid for use only with MiTek® connectors. This design is based only upon parameters shown, and is for an individual building component, not a truss system. Before use, the building designer must verify the applicability of design parameters and properly incorporate this design into the overall building design. Bracing indicated is to prevent buckling of individual truss web and/or chord members only. Additional temporary and permanent bracing is always required for stability and to prevent collapse with possible personal injury and property damage. For general guidance regarding the fabrication, storage, delivery, erection and bracing of trusses and truss systems, see

ANSI/TPI1 Quality Criteria, DSB-89 and BCSI Building Component

Safety Information available from Truss Plate Institute, 2670 Crain Highway, Suite 203 Waldorf, MD 20601



6904 Parke East Blvd.
Tampa, FL 36610

Job	Truss	Truss Type	Qty	Ply	EVANS - FT WHITE SPEC	T26813916
3070916	HJ08	Diagonal Hip Girder	1	1	Job Reference (optional)	

Builders FirstSource (Lake City,FL), Lake City, FL - 32055,

8.430 s Aug 16 2021 MiTek Industries, Inc. Thu Feb 10 16:08:55 2022 Page 1

ID:KlqOOOpJ4Z1Cn3VD1sa2GzOzmc6D-GHofh13g2NLCPLeZJ0o3OF6GyyB1HxsjDXiHNzmUm6



Scale: 1/2"=1'

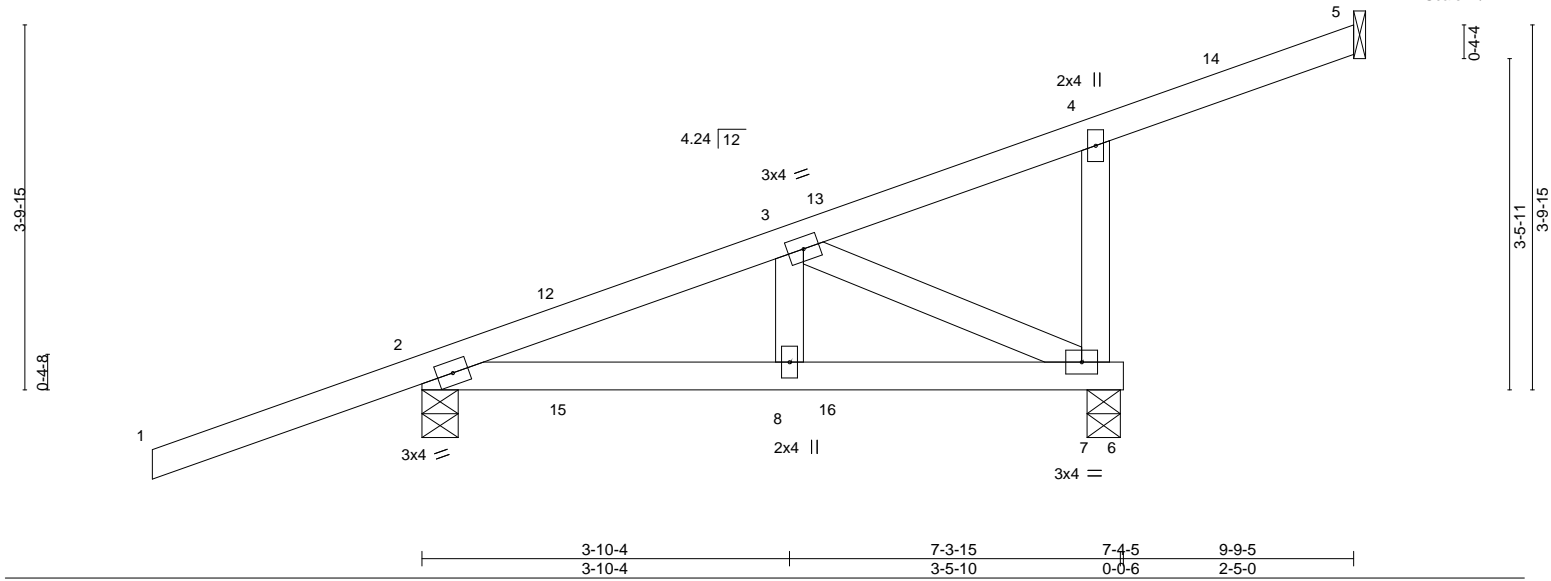

LOADING (psf)	SPACING-	CSI.	DEFL.	in	(loc)	l/defl	L/d	PLATES	GRIP
TCLL 20.0	Plate Grip DOL 1.25	TC 0.56	Vert(LL) 0.03	8-11	>999	240		MT20	244/190
TCDL 7.0	Lumber DOL 1.25	BC 0.37	Vert(CT) 0.03	8-11	>999	180			
BCLL 0.0 *	Rep Stress Incr NO	WB 0.06	Horz(CT) -0.00	2	n/a	n/a			
BCDL 10.0	Code FBC2020/TPI2014	Matrix-MS						Weight: 41 lb	FT = 20%

LUMBER-	BRACING-
TOP CHORD 2x4 SP No.2	TOP CHORD Structural wood sheathing directly applied or 6-0-0 oc purlins, except end verticals.
BOT CHORD 2x4 SP No.2	BOT CHORD Rigid ceiling directly applied or 6-0-0 oc bracing.
WEBS 2x4 SP No.3	

REACTIONS. (size) 5=Mechanical, 2=0-4-9, 7=0-4-3
 Max Horz 2=159(LC 4)
 Max Uplift 5=-20(LC 26), 2=-162(LC 4), 7=-202(LC 4)
 Max Grav 5=51(LC 1), 2=341(LC 1), 7=409(LC 1)

FORCES. (lb) - Max. Comp./Max. Ten. - All forces 250 (lb) or less except when shown.
 TOP CHORD 2-3=-287/69, 4-7=-256/163

- NOTES-**
- 1) Wind: ASCE 7-16; Vult=130mph (3-second gust) Vasd=101mph; TCDL=4.2psf; BCDL=3.0psf; h=20ft; Cat. II; Exp B; Encl., GCpi=0.18; MWFRS (envelope) gable end zone; porch left exposed; Lumber DOL=1.60 plate grip DOL=1.60
 - 2) Building Designer / Project engineer responsible for verifying applied roof live load shown covers rain loading requirements specific to the use of this truss component.
 - 3) This truss has been designed for a 10.0 psf bottom chord live load nonconcurrent with any other live loads.
 - 4) * This truss has been designed for a live load of 20.0psf on the bottom chord in all areas where a rectangle 3-6-0 tall by 2-0-0 wide will fit between the bottom chord and any other members.
 - 5) Refer to girder(s) for truss to truss connections.
 - 6) Provide mechanical connection (by others) of truss to bearing plate capable of withstanding 20 lb uplift at joint 5, 162 lb uplift at joint 2 and 202 lb uplift at joint 7.
 - 7) Hanger(s) or other connection device(s) shall be provided sufficient to support concentrated load(s) 54 lb down and 103 lb up at 1-6-1, 54 lb down and 103 lb up at 1-6-1, 20 lb down and 33 lb up at 4-4-0, 20 lb down and 33 lb up at 4-4-0, and 41 lb down and 75 lb up at 7-1-15, and 41 lb down and 75 lb up at 7-1-15 on top chord, and 44 lb down and 74 lb up at 1-6-1, 44 lb down and 74 lb up at 1-6-1, 42 lb down and 21 lb up at 4-4-0, and 42 lb down and 21 lb up at 4-4-0, and 56 lb down at 7-4-5 on bottom chord. The design/selection of such connection device(s) is the responsibility of others.
 - 8) In the LOAD CASE(S) section, loads applied to the face of the truss are noted as front (F) or back (B).

LOAD CASE(S) Standard

- 1) Dead + Roof Live (balanced): Lumber Increase=1.25, Plate Increase=1.25

Uniform Loads (plf)
 Vert: 1-4=-54, 4-5=-54, 6-9=-20

Concentrated Loads (lb)
 Vert: 4=-64(F=-32, B=-32) 7=-37(F) 12=50(F=25, B=25) 15=70(F=35, B=35) 16=5(F=2, B=2)

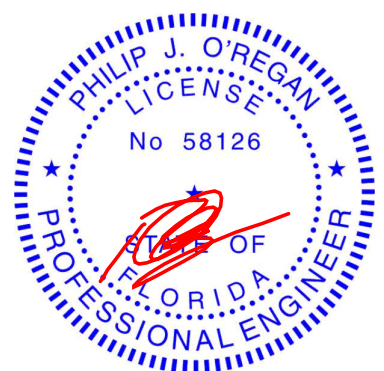

Philip J. O'Regan PE No.58126
 MiTek USA, Inc. FL Cert 6634
 6904 Parke East Blvd. Tampa FL 33610
 Date:

February 11, 2022

Job	Truss	Truss Type	Qty	Ply	EVANS - FT WHITE SPEC	T26813917
3070916	HJ10	Diagonal Hip Girder	1	1		

Builders FirstSource (Lake City,FL), Lake City, FL - 32055,

8.430 s Aug 16 2021 MiTek Industries, Inc. Thu Feb 10 16:08:56 2022 Page 1

ID:KlqOOOpJ4Z1Cn3VD1sa2GzOzmc6D-kTM2ve4lphT30VYQ60X1cboGXMEImfg0xtGFqzqmUm5

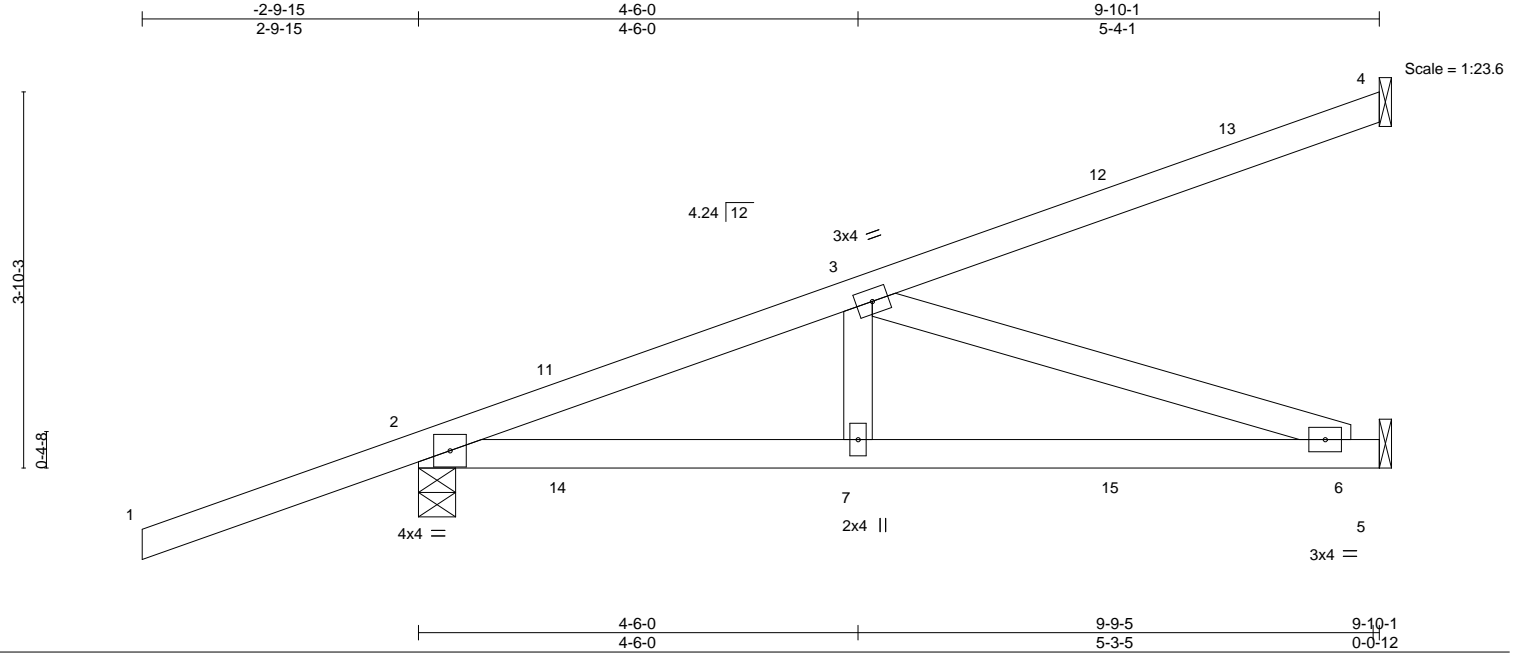

LOADING (psf)	SPACING-	CSI.	DEFL.	in (loc)	l/defl	L/d	PLATES	GRIP
TCLL 20.0	Plate Grip DOL 1.25	TC 0.59	Vert(LL) -0.05	6-7	>999	240	MT20	244/190
TCDL 7.0	Lumber DOL 1.25	BC 0.61	Vert(CT) -0.12	6-7	>967	180		
BCLL 0.0 *	Rep Stress Incr NO	WB 0.35	Horz(CT) 0.01	5	n/a	n/a		
BCDL 10.0	Code FBC2020/TPI2014	Matrix-MS					Weight: 44 lb	FT = 20%

LUMBER-	BRACING-
TOP CHORD 2x4 SP No.2	TOP CHORD Structural wood sheathing directly applied or 6-0-0 oc purlins.
BOT CHORD 2x4 SP No.2	BOT CHORD Rigid ceiling directly applied or 10-0-0 oc bracing.
WEBS 2x4 SP No.3	

REACTIONS. (size) 4=Mechanical, 2=0-4-9, 5=Mechanical
 Max Horz 2=160(LC 4)
 Max Uplift 4=-79(LC 4), 2=-200(LC 4), 5=-63(LC 8)
 Max Grav 4=150(LC 1), 2=463(LC 1), 5=266(LC 3)

FORCES. (lb) - Max. Comp./Max. Ten. - All forces 250 (lb) or less except when shown.
 TOP CHORD 2-3=-628/212
 BOT CHORD 2-7=-247/573, 6-7=-247/573
 WEBS 3-6=-603/260

- NOTES-**
- 1) Wind: ASCE 7-16; Vult=130mph (3-second gust) Vasd=101mph; TCDL=4.2psf; BCDL=3.0psf; h=20ft; Cat. II; Exp B; Encl., GCpi=0.18; MWFRS (envelope) gable end zone; Lumber DOL=1.60 plate grip DOL=1.60
 - 2) Building Designer / Project engineer responsible for verifying applied roof live load shown covers rain loading requirements specific to the use of this truss component.
 - 3) This truss has been designed for a 10.0 psf bottom chord live load nonconcurrent with any other live loads.
 - 4) * This truss has been designed for a live load of 20.0psf on the bottom chord in all areas where a rectangle 3-6-0 tall by 2-0-0 wide will fit between the bottom chord and any other members.
 - 5) Refer to girder(s) for truss to truss connections.
 - 6) Provide mechanical connection (by others) of truss to bearing plate capable of withstanding 79 lb uplift at joint 4, 200 lb uplift at joint 2 and 63 lb uplift at joint 5.
 - 7) Hanger(s) or other connection device(s) shall be provided sufficient to support concentrated load(s) 54 lb down and 103 lb up at 1-6-1, 54 lb down and 103 lb up at 1-6-1, 20 lb down and 33 lb up at 4-4-0, 20 lb down and 33 lb up at 4-4-0, and 41 lb down and 75 lb up at 7-1-15, and 41 lb down and 75 lb up at 7-1-15 on top chord, and 21 lb down and 14 lb up at 1-6-1, 21 lb down and 74 lb up at 1-6-1, 19 lb down and 21 lb up at 4-4-0, 19 lb down and 21 lb up at 4-4-0, and 42 lb down at 7-1-15, and 42 lb down at 7-1-15 on bottom chord. The design/selection of such connection device(s) is the responsibility of others.
 - 8) In the LOAD CASE(S) section, loads applied to the face of the truss are noted as front (F) or back (B).

LOAD CASE(S) Standard

- 1) Dead + Roof Live (balanced): Lumber Increase=1.25, Plate Increase=1.25
 Uniform Loads (plf)
 Vert: 1-4=-54, 5-8=-20
 Concentrated Loads (lb)
 Vert: 7=5(F=2, B=2) 11=50(F=25, B=25) 12=-64(F=-32, B=-32) 14=70(F=35, B=35) 15=-49(F=-24, B=-24)

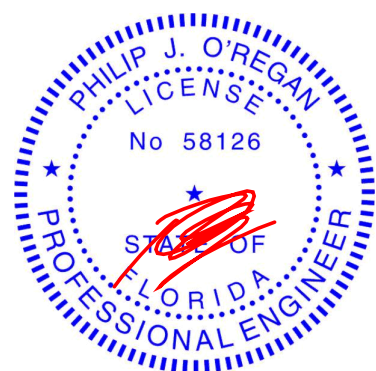

Philip J. O'Regan PE No.58126
 MiTek USA, Inc. FL Cert 6634
 6904 Parke East Blvd. Tampa FL 33610
 Date:

February 11, 2022

WARNING - Verify design parameters and READ NOTES ON THIS AND INCLUDED MITEK REFERENCE PAGE MII-7473 rev. 5/19/2020 BEFORE USE.
 Design valid for use only with MiTek® connectors. This design is based only upon parameters shown, and is for an individual building component, not a truss system. Before use, the building designer must verify the applicability of design parameters and properly incorporate this design into the overall building design. Bracing indicated is to prevent buckling of individual truss web and/or chord members only. Additional temporary and permanent bracing is always required for stability and to prevent collapse with possible personal injury and property damage. For general guidance regarding the fabrication, storage, delivery, erection and bracing of trusses and truss systems, see **ANSI/TPI1 Quality Criteria, DSB-89 and BCSI Building Component Safety Information** available from Truss Plate Institute, 2670 Crain Highway, Suite 203 Waldorf, MD 20601

6904 Parke East Blvd.
 Tampa, FL 36610

Job	Truss	Truss Type	Qty	Ply	EVANS - FT WHITE SPEC	T26813918
3070916	HJ10A	Diagonal Hip Girder	1	1		

Builders FirstSource (Lake City,FL), Lake City, FL - 32055,

8.430 s Aug 16 2021 MiTek Industries, Inc. Thu Feb 10 16:08:59 2022 Page 1

ID:KlqOOOpJ4Z1Cn3VD1sa2GzOzmc6D-821AXf7A5cretyG?o85kEEQn3ZAqz?CSerVvQ8zmUm2

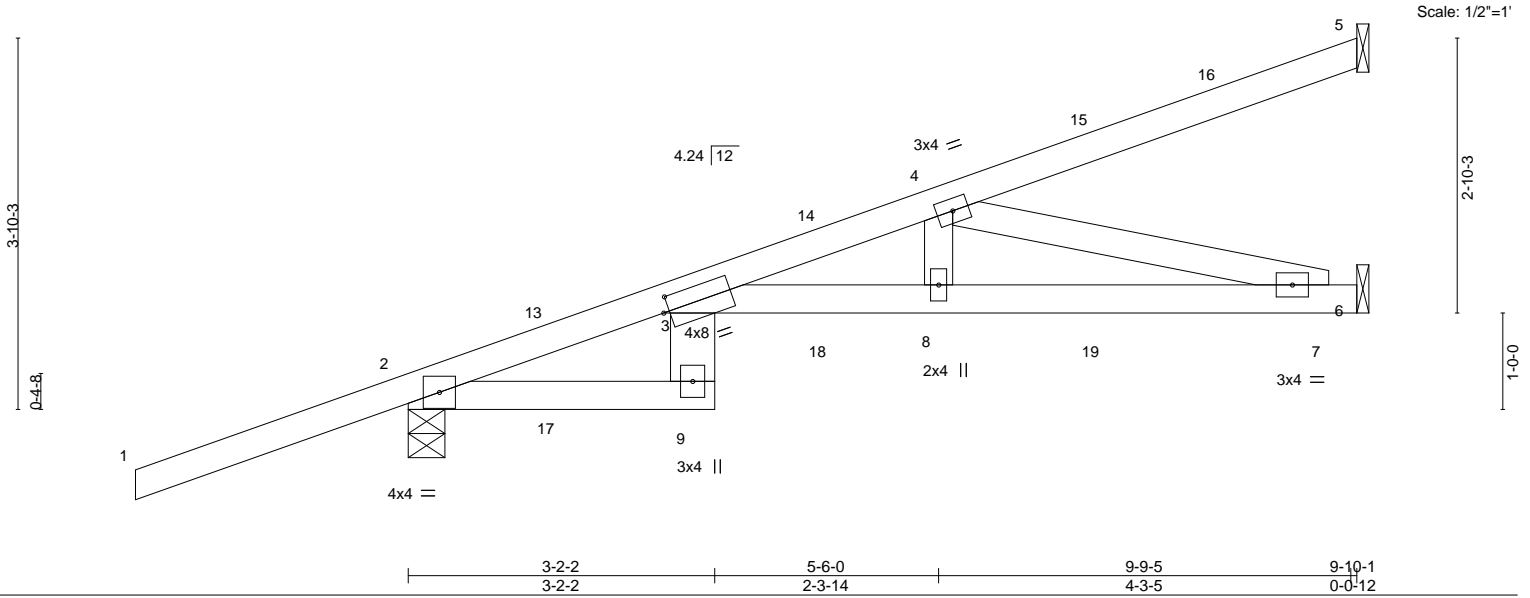

Plate Offsets (X,Y)-- [3:0-0-12,0-1-14]

LOADING (psf)	SPACING-	CSI.	DEFL.	PLATES	GRIP
TCLL 20.0	Plate Grip DOL 1.25	TC 0.57	in (loc) l/defl L/d	MT20	244/190
TCDL 7.0	Lumber DOL 1.25	BC 0.90	Vert(LL) -0.19 3-8 >616 240		
BCLL 0.0 *	Rep Stress Incr NO	WB 0.42	Vert(CT) -0.30 3-8 >388 180		
BCDL 10.0	Code FBC2020/TPI2014	Matrix-MS	Horz(CT) 0.13 6 n/a n/a		
				Weight: 44 lb	FT = 20%

LUMBER-

TOP CHORD 2x4 SP M 31
 BOT CHORD 2x4 SP No.2 *Except*
 3-9: 2x6 SP No.2
 WEBS 2x4 SP No.3

BRACING-

TOP CHORD Structural wood sheathing directly applied or 6-0-0 oc purlins.
 BOT CHORD Rigid ceiling directly applied or 6-0-0 oc bracing.

REACTIONS.

(size) 5=Mechanical, 2=0-4-9, 6=Mechanical
 Max Horz 2=160(LC 22)
 Max Uplift 5=-48(LC 4), 2=-199(LC 4), 6=-102(LC 8)
 Max Grav 5=105(LC 19), 2=476(LC 1), 6=308(LC 1)

FORCES. (lb) - Max. Comp./Max. Ten. - All forces 250 (lb) or less except when shown.

TOP CHORD 3-11=-276/29, 3-4=-1120/383
 BOT CHORD 3-8=-444/1086, 7-8=-446/1091
 WEBS 4-8=-54/289, 4-7=-1125/460

NOTES-

- Wind: ASCE 7-16; Vult=130mph (3-second gust) Vasd=101mph; TCDL=4.2psf; BCDL=3.0psf; h=20ft; Cat. II; Exp B; Encl., GCpi=0.18; MWFRS (envelope) gable end zone; Lumber DOL=1.60 plate grip DOL=1.60
- Building Designer / Project engineer responsible for verifying applied roof live load shown covers rain loading requirements specific to the use of this truss component.
- This truss has been designed for a 10.0 psf bottom chord live load nonconcurrent with any other live loads.
- * This truss has been designed for a live load of 20.0psf on the bottom chord in all areas where a rectangle 3-6-0 tall by 2-0-0 wide will fit between the bottom chord and any other members.
- Refer to girder(s) for truss to truss connections.
- Provide mechanical connection (by others) of truss to bearing plate capable of withstanding 48 lb uplift at joint 5, 199 lb uplift at joint 2 and 102 lb uplift at joint 6.
- Hanger(s) or other connection device(s) shall be provided sufficient to support concentrated load(s) 54 lb down and 103 lb up at 1-6-1, 54 lb down and 103 lb up at 1-6-1, 64 lb down and 18 lb up at 4-4-0, 64 lb down and 18 lb up at 4-4-0, and 41 lb down and 60 lb up at 7-1-15, and 41 lb down and 60 lb up at 7-1-15 on top chord, and 21 lb down and 74 lb up at 1-6-1, 21 lb down and 74 lb up at 1-6-1, 23 lb down and 14 lb up at 4-4-0, 23 lb down and 14 lb up at 4-4-0, and 40 lb down and 25 lb up at 7-1-15, and 40 lb down and 25 lb up at 7-1-15 on bottom chord. The design/selection of such connection device(s) is the responsibility of others.
- In the LOAD CASE(S) section, loads applied to the face of the truss are noted as front (F) or back (B).

LOAD CASE(S) Standard

- Dead + Roof Live (balanced): Lumber Increase=1.25, Plate Increase=1.25
 Uniform Loads (plf)
 Vert: 1-3=-54, 3-5=-54, 9-10=-20, 3-6=-20
 Concentrated Loads (lb)
 Vert: 13=50(F=25, B=25) 15=-39(F=-20, B=-20) 17=70(F=35, B=35) 18=-20(F=-10, B=-10) 19=-73(F=-37, B=-37)



Philip J. O'Regan PE No.58126
 MiTek USA, Inc. FL Cert 6634
 6904 Parke East Blvd. Tampa FL 33610
 Date:

February 11, 2022

WARNING - Verify design parameters and READ NOTES ON THIS AND INCLUDED MITEK REFERENCE PAGE MII-7473 rev. 5/19/2020 BEFORE USE.

Design valid for use only with MiTek® connectors. This design is based only upon parameters shown, and is for an individual building component, not a truss system. Before use, the building designer must verify the applicability of design parameters and properly incorporate this design into the overall building design. Bracing indicated is to prevent buckling of individual truss web and/or chord members only. Additional temporary and permanent bracing is always required for stability and to prevent collapse with possible personal injury and property damage. For general guidance regarding the fabrication, storage, delivery, erection and bracing of trusses and truss systems, see

ANSI/TPI1 Quality Criteria, DSB-89 and BCSI Building Component

Safety Information available from Truss Plate Institute, 2670 Crain Highway, Suite 203 Waldorf, MD 20601



6904 Parke East Blvd.
 Tampa, FL 36610

Job 3070916	Truss T01	Truss Type Hip Girder	Qty 1	Ply 2	EVANS - FT WHITE SPEC Job Reference (optional)	T26813919
----------------	--------------	--------------------------	----------	----------	---	-----------

Builders FirstSource (Lake City, FL), Lake City, FL - 32055,

8.430 s Aug 16 2021 MiTek Industries, Inc. Thu Feb 10 16:09:03 2022 Page 1

ID:KlqOOpJ4Z1Cn3VD1sa2GzOzmc6D-1qHhN1Ah9qL4Maam1_9gO4aPMBbvwX2YTT7awzmUm_

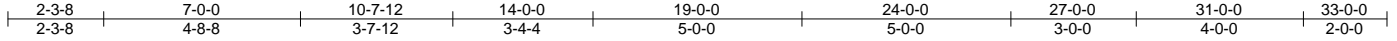

Scale = 1:55.1

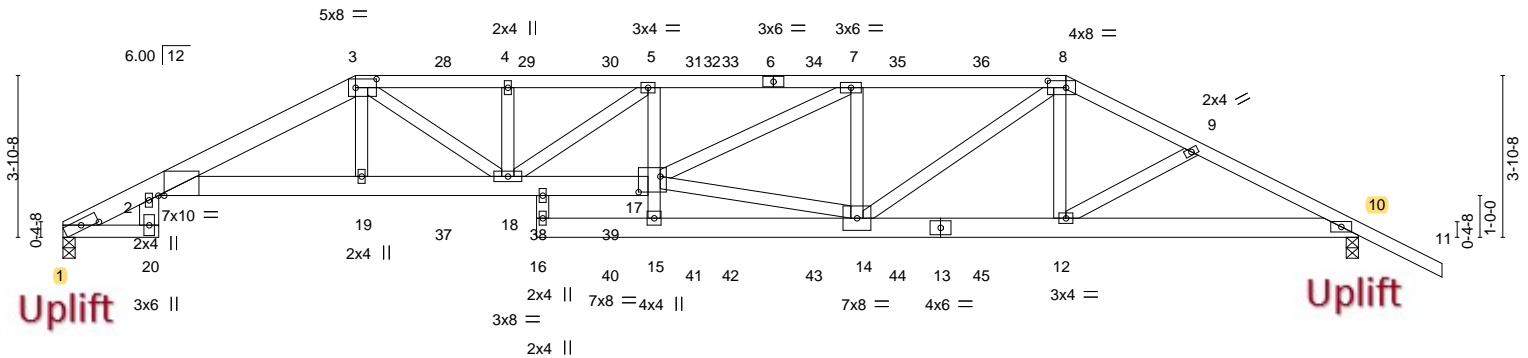

Plate Offsets (X,Y)--	[1:0-5-0,0-1-7], [2:0-1-11,0-0-0], [3:0-6-0,0-2-8], [8:0-5-4,0-2-0], [17:0-6-4,0-4-8]
-----------------------	---

LOADING (psf)	SPACING-	CSI.	DEFL.	PLATES	GRIP
TCLL 20.0	Plate Grip DOL 1.25	TC 0.80	Vert(LL) -0.37 16 >999 240	MT20	244/190
TCDL 7.0	Lumber DOL 1.25	BC 0.76	Vert(CT) -0.71 16 >522 180		
BCLL 0.0 *	Rep Stress Incr NO	WB 0.91	Horz(CT) 0.29 10 n/a n/a		
BCDL 10.0	Code FBC2020/TP12014	Matrix-MS		Weight: 394 lb	FT = 20%

LUMBER-	BRACING-
TOP CHORD 2x4 SP No.2 *Except* 1-3: 2x6 SP M 26	TOP CHORD Structural wood sheathing directly applied or 3-11-2 oc purlins.
BOT CHORD 2x6 SP No.2 *Except* 1-20,5-15: 2x4 SP No.2, 2-17: 2x6 SP M 26	BOT CHORD Rigid ceiling directly applied or 10-0-0 oc bracing. Except: 10-0-0 oc bracing: 15-17
WEBS 2x4 SP No.3	

REACTIONS. (size) 1=0-3-8, 10=0-3-8
 Max Horz 1=-82(LC 13)
 Max Uplift 1=634(LC 8), 10=654(LC 9)
 Max Grav 1=2295(LC 1), 10=2400(LC 3)

FORCES. (lb) - Max. Comp./Max. Ten. - All forces 250 (lb) or less except when shown.
 TOP CHORD 2-25=-1675/473, 2-3=-6502/1810, 3-4=-7166/1961, 4-5=-7166/1961, 5-7=-8212/2172,
 7-8=-5499/1470, 8-9=-4575/1235, 9-10=-4734/1275
 BOT CHORD 1-20=-105/374, 2-20=-232/836, 2-19=-1607/5900, 18-19=-1629/5982, 17-18=-2130/8315,
 15-17=0/429, 5-17=0/480, 14-15=-220/889, 12-14=-1008/4093, 10-12=-1063/4193
 WEBS 3-19=-382/1404, 3-18=-414/1540, 4-18=-292/156, 5-18=-1430/342, 14-17=-1229/4795,
 7-17=-794/2946, 7-14=-1912/651, 8-14=-488/1765, 8-12=-70/666

- NOTES-**
- 2-ply truss to be connected together with 10d (0.131"x3") nails as follows:
 Top chords connected as follows: 2x6 - 2 rows staggered at 0-9-0 oc, 2x4 - 1 row at 0-9-0 oc.
 Bottom chords connected as follows: 2x4 - 1 row at 0-9-0 oc, 2x6 - 2 rows staggered at 0-9-0 oc.
 Webs connected as follows: 2x4 - 1 row at 0-9-0 oc.
 - All loads are considered equally applied to all plies, except if noted as front (F) or back (B) face in the LOAD CASE(S) section. Ply to ply connections have been provided to distribute only loads noted as (F) or (B), unless otherwise indicated.
 - Unbalanced roof live loads have been considered for this design.
 - Wind: ASCE 7-16; Vult=130mph (3-second gust) Vasd=101mph; TCDL=4.2psf; BCDL=3.0psf; h=20ft; Cat. II; Exp B; Encl., GCpi=0.18; MWFRS (envelope) gable end zone; Lumber DOL=1.60 plate grip DOL=1.60
 - Building Designer / Project engineer responsible for verifying applied roof live load shown covers rain loading requirements specific to the use of this truss component.
 - Provide adequate drainage to prevent water ponding.
 - This truss has been designed for a 10.0 psf bottom chord live load nonconcurrent with any other live loads.
 - * This truss has been designed for a live load of 20.0psf on the bottom chord in all areas where a rectangle 3-6-0 tall by 2-0-0 wide will fit between the bottom chord and any other members.
 - Provide mechanical connection (by others) of truss to bearing plate capable of withstanding 634 lb uplift at joint 1 and 654 lb uplift at joint 10.

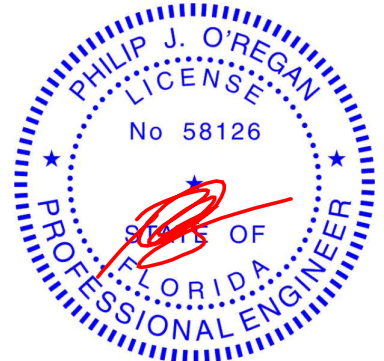

Philip J. O'Regan PE No.58126
 MiTek USA, Inc. FL Cert 6634
 6904 Parke East Blvd. Tampa FL 33610
 Date:

February 11, 2022

Continued on page 2

WARNING - Verify design parameters and READ NOTES ON THIS AND INCLUDED MITEK REFERENCE PAGE MII-7473 rev. 5/19/2020 BEFORE USE.
 Design valid for use only with MiTek® connectors. This design is based only upon parameters shown, and is for an individual building component, not a truss system. Before use, the building designer must verify the applicability of design parameters and properly incorporate this design into the overall building design. Bracing indicated is to prevent buckling of individual truss web and/or chord members only. Additional temporary and permanent bracing is always required for stability and to prevent collapse with possible personal injury and property damage. For general guidance regarding the fabrication, storage, delivery, erection and bracing of trusses and truss systems, see ANSIT/TP1 Quality Criteria, DSB-89 and BCSI Building Component Safety Information available from Truss Plate Institute, 2670 Crain Highway, Suite 203 Waldorf, MD 20601



Job	Truss	Truss Type	Qty	Ply	EVANS - FT WHITE SPEC	T26813919
3070916	T01	Hip Girder	1	2	Job Reference (optional)	

Builders FirstSource (Lake City,FL), Lake City, FL - 32055,

8.430 s Aug 16 2021 MiTek Industries, Inc. Thu Feb 10 16:09:04 2022 Page 2
ID:KlqOOpJ4Z1Cn3VD1sa2GzOzmc6D-V0q3aNAJw8Uw_j9zaigvxH7a6aw9e8nBn7Cg5MzmUlz

NOTES-

- 10) Hanger(s) or other connection device(s) shall be provided sufficient to support concentrated load(s) 113 lb down and 75 lb up at 7-0-0, 94 lb down and 75 lb up at 9-0-12, 94 lb down and 75 lb up at 11-0-12, 106 lb down and 88 lb up at 13-0-12, 106 lb down and 84 lb up at 15-0-12, 106 lb down and 84 lb up at 15-11-4, 106 lb down and 88 lb up at 17-11-4, 106 lb down and 88 lb up at 19-11-4, and 106 lb down and 88 lb up at 21-11-4, and 227 lb down and 174 lb up at 24-0-0 on top chord, and 353 lb down and 161 lb up at 7-0-0, 78 lb down and 30 lb up at 9-0-12, 78 lb down and 30 lb up at 11-4-0, 85 lb down at 13-0-12, 85 lb down at 15-0-12, 85 lb down at 15-11-4, 85 lb down at 17-11-4, 85 lb down at 19-11-4, and 85 lb down at 21-11-4, and 294 lb down and 90 lb up at 23-11-4 on bottom chord. The design/selection of such connection device(s) is the responsibility of others.
- 11) Filler applied to ply: 1(Front)

LOAD CASE(S) Standard

- 1) Dead + Roof Live (balanced): Lumber Increase=1.25, Plate Increase=1.25

Uniform Loads (plf)

Vert: 2-24=-54, 2-3=-54, 3-8=-54, 8-11=-54, 1-20=-20, 2-17=-20, 15-16=-20, 10-15=-20

Concentrated Loads (lb)

Vert: 3=-94(F) 8=-180(F) 19=-353(F) 12=-284(F) 28=-94(F) 29=-94(F) 30=-106(F) 31=-106(F) 33=-106(F) 34=-106(F) 35=-106(F) 36=-106(F) 37=-73(F) 38=-73(F) 39=-61(F) 41=-61(F) 42=-61(F) 43=-61(F) 44=-61(F) 45=-61(F)

WARNING - Verify design parameters and READ NOTES ON THIS AND INCLUDED MITEK REFERENCE PAGE MII-7473 rev. 5/19/2020 BEFORE USE.

Design valid for use only with MiTek® connectors. This design is based only upon parameters shown, and is for an individual building component, not a truss system. Before use, the building designer must verify the applicability of design parameters and properly incorporate this design into the overall building design. Bracing indicated is to prevent buckling of individual truss web and/or chord members only. Additional temporary and permanent bracing is always required for stability and to prevent collapse with possible personal injury and property damage. For general guidance regarding the fabrication, storage, delivery, erection and bracing of trusses and truss systems, see **ANSI/TPI1 Quality Criteria, DSB-89 and BCSI Building Component**

Safety Information available from Truss Plate Institute, 2670 Crain Highway, Suite 203 Waldorf, MD 20601



6904 Parke East Blvd.
Tampa, FL 36610

Job 3070916	Truss T03	Truss Type Hip	Qty 1	Ply 1	EVANS - FT WHITE SPEC	T26813921
----------------	--------------	-------------------	----------	----------	-----------------------	-----------

Builders FirstSource (Lake City, FL), Lake City, FL - 32055, 8.430 s Aug 16 2021 MiTek Industries, Inc. Thu Feb 10 16:09:06 2022 Page 1
 ID:KlqOOpJ4Z1Cn3VD1sa2GzOzmc6D-RPyp?2CZSikeD1Li6jN0iCzAOd8677UFRhn9EzmUlx

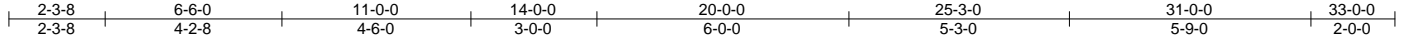

Scale = 1:54.9

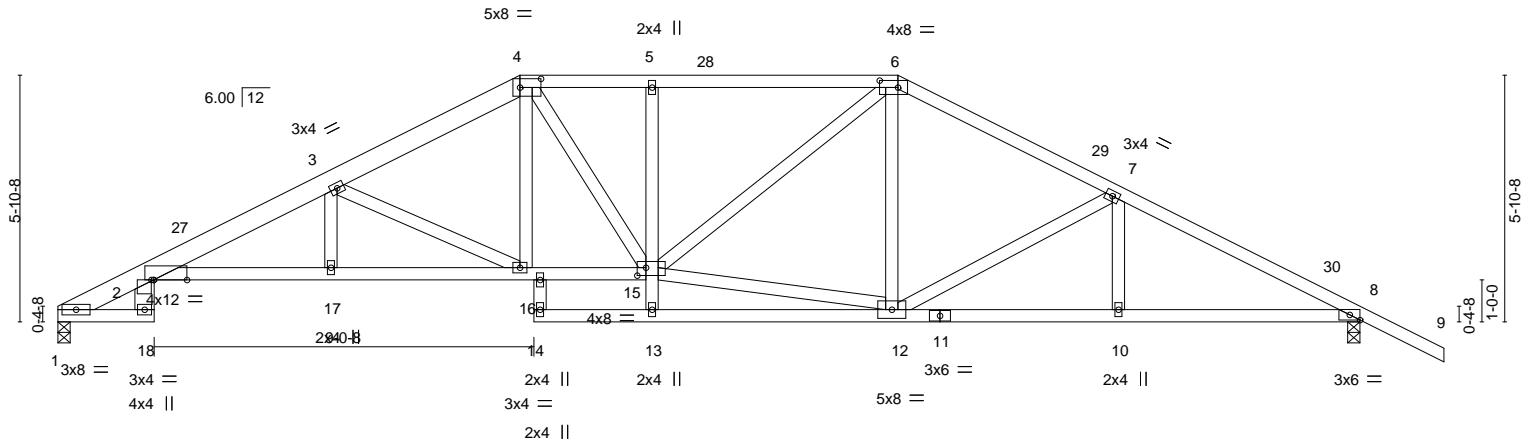

Plate Offsets (X,Y)--	[2:0-0-0,0-0-11], [2:0-9-8,0-0-0], [4:0-6-0,0-2-8], [6:0-5-4,0-2-0], [8:0-2-15,Edge], [15:0-2-8,0-2-4]
-----------------------	--

LOADING (psf)	SPACING-	CSI.	DEFL.	PLATES	GRIP
TCLL 20.0	Plate Grip DOL 1.25	TC 0.64	in (loc) l/defl L/d	MT20	244/190
TCDL 7.0	Lumber DOL 1.25	BC 0.67	Vert(LL) -0.25 2-17 >999 240		
BCLL 0.0 *	Rep Stress Incr YES	WB 0.60	Vert(CT) -0.52 14 >711 180		
BCDL 10.0	Code FBC2020/TPI2014	Matrix-MS	Horz(CT) 0.28 8 n/a n/a		
				Weight: 187 lb	FT = 20%

LUMBER-
 TOP CHORD 2x4 SP No.2 *Except*
 1-4: 2x6 SP M 26
 BOT CHORD 2x4 SP No.2 *Except*
 2-18: 2x6 SP No.2, 2-15: 2x4 SP M 31, 5-13: 2x4 SP No.3
 WEBS 2x4 SP No.3

BRACING-
 TOP CHORD Structural wood sheathing directly applied or 3-7-10 oc purlins.
 BOT CHORD Rigid ceiling directly applied or 10-0-0 oc bracing. Except:
 10-0-0 oc bracing: 13-15

REACTIONS. (size) 1=0-3-8, 8=0-3-8
 Max Horz 1=111(LC 17)
 Max Uplift 1=231(LC 12), 8=282(LC 13)
 Max Grav 1=1174(LC 1), 8=1276(LC 1)

FORCES. (lb) - Max. Comp./Max. Ten. - All forces 250 (lb) or less except when shown.
 TOP CHORD 2-23=-769/185, 2-3=-3079/594, 3-4=-2138/407, 4-5=-2012/416, 5-6=-2009/417,
 6-7=-1750/369, 7-8=-2166/421
 BOT CHORD 2-18=-79/375, 2-17=-563/2888, 16-17=-563/2888, 15-16=-259/1829, 5-15=-298/145,
 10-12=-297/1882, 8-10=-297/1882
 WEBS 3-17=-4/295, 3-16=-1195/342, 4-16=-118/594, 4-15=-113/416, 12-15=-161/1426,
 6-15=-141/703, 7-12=-438/181

- NOTES-**
- Unbalanced roof live loads have been considered for this design.
 - Wind: ASCE 7-16; Vult=130mph (3-second gust) Vasd=101mph; TCDL=4.2psf; BCDL=3.0psf; h=20ft; Cat. II; Exp B; Encl., GCpi=0.18; MWFRS (envelope) gable end zone and C-C Exterior(2E) 0-1-12 to 3-2-15, Interior(1) 3-2-15 to 11-0-0, Exterior(2R) 11-0-0 to 15-4-10, Interior(1) 15-4-10 to 20-0-0, Exterior(2R) 20-0-0 to 24-4-10, Interior(1) 24-4-10 to 33-0-0 zone; C-C for members and forces & MWFRS for reactions shown; Lumber DOL=1.60 plate grip DOL=1.60
 - Building Designer / Project engineer responsible for verifying applied roof live load shown covers rain loading requirements specific to the use of this truss component.
 - Provide adequate drainage to prevent water ponding.
 - This truss has been designed for a 10.0 psf bottom chord live load nonconcurrent with any other live loads.
 - * This truss has been designed for a live load of 20.0psf on the bottom chord in all areas where a rectangle 3-6-0 tall by 2-0-0 wide will fit between the bottom chord and any other members.
 - Provide mechanical connection (by others) of truss to bearing plate capable of withstanding 231 lb uplift at joint 1 and 282 lb uplift at joint 8.

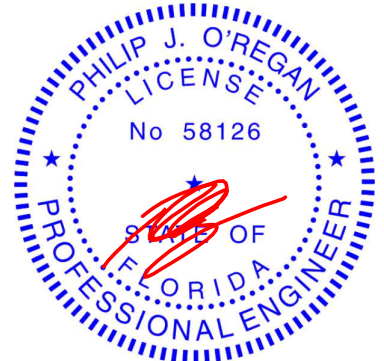

Philip J. O'Regan PE No.58126
 MiTek USA, Inc. FL Cert 6634
 6904 Parke East Blvd. Tampa FL 33610
 Date: February 11, 2022

WARNING - Verify design parameters and READ NOTES ON THIS AND INCLUDED MITEK REFERENCE PAGE MII-7473 rev. 5/19/2020 BEFORE USE.
 Design valid for use only with MiTek® connectors. This design is based only upon parameters shown, and is for an individual building component, not a truss system. Before use, the building designer must verify the applicability of design parameters and properly incorporate this design into the overall building design. Bracing indicated is to prevent buckling of individual truss web and/or chord members only. Additional temporary and permanent bracing is always required for stability and to prevent collapse with possible personal injury and property damage. For general guidance regarding the fabrication, storage, delivery, erection and bracing of trusses and truss systems, see **ANSI/TPI1 Quality Criteria, DSB-89 and BCSI Building Component Safety Information** available from Truss Plate Institute, 2670 Crain Highway, Suite 203 Waldorf, MD 20601

6904 Parke East Blvd.
 Tampa, FL 33610

Job 3070916	Truss T04	Truss Type Hip	Qty 1	Ply 1	EVANS - FT WHITE SPEC	T26813922
----------------	--------------	-------------------	----------	----------	-----------------------	-----------

Builders FirstSource (Lake City,FL), Lake City, FL - 32055,

8.430 s Aug 16 2021 MiTek Industries, Inc. Thu Feb 10 16:09:07 2022 Page 1

ID:KlqOOpJ4Z1Cn3VD1sa2GzOzmc6D-vbWCDODCD3sVrBtXGqEcYwBQo?nrbdT5RKihzmUlw

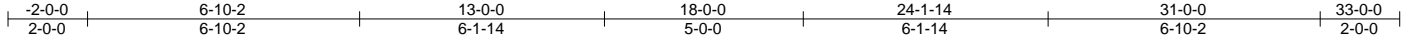

Scale = 1:57.9

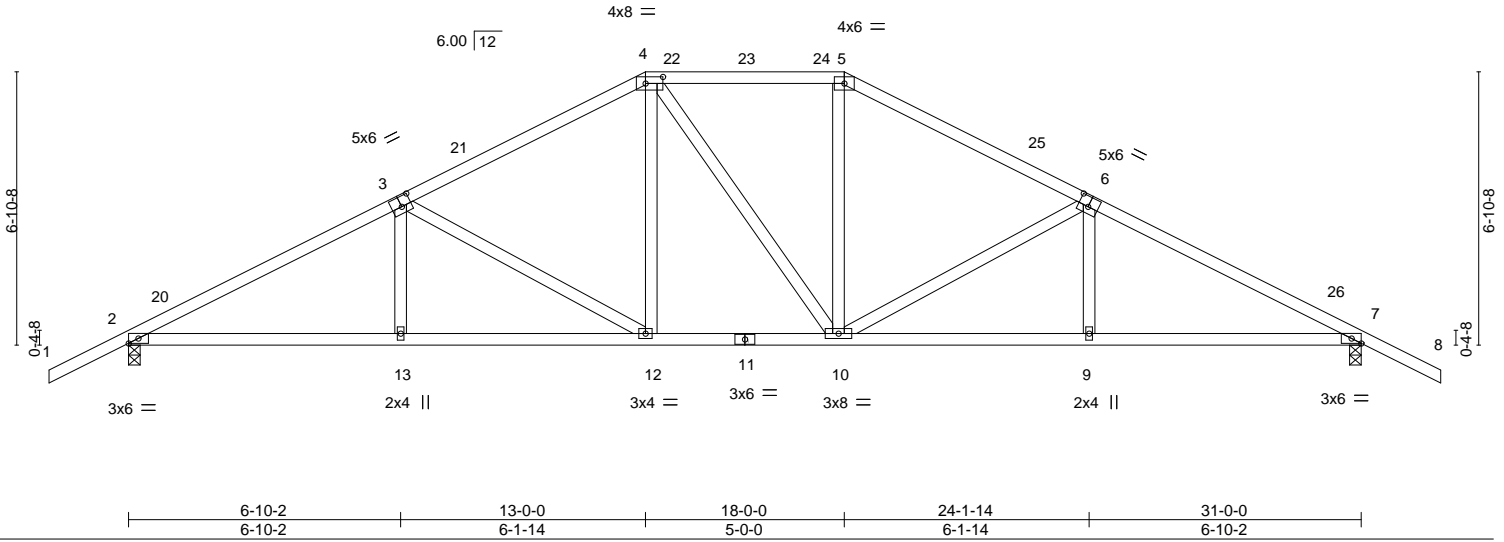

Plate Offsets (X,Y)-- [3:0-3-0,0-3-0], [4:0-5-4,0-2-0], [6:0-3-0,0-3-0], [7:0-2-15,Edge]

LOADING (psf)	SPACING-	CSI.	DEFL.	PLATES	GRIP
TCLL 20.0	Plate Grip DOL 1.25	TC 0.42	in (loc) l/defl L/d	MT20	244/190
TCDL 7.0	Lumber DOL 1.25	BC 0.58	Vert(LL) -0.10 12 >999 240		
BCLL 0.0 *	Rep Stress Incr YES	WB 0.56	Vert(CT) -0.21 12-13 >999 180		
BCDL 10.0	Code FBC2020/TPI2014	Matrix-MS	Horz(CT) 0.08 7 n/a n/a	Weight: 164 lb	FT = 20%

LUMBER-

TOP CHORD 2x4 SP No.2
 BOT CHORD 2x4 SP No.2
 WEBS 2x4 SP No.3

BRACING-

TOP CHORD Structural wood sheathing directly applied or 3-8-9 oc purlins.
 BOT CHORD Rigid ceiling directly applied or 9-4-14 oc bracing.

REACTIONS.

(size) 2=0-3-8, 7=0-3-8
 Max Horz 2=112(LC 12)
 Max Uplift 2=-286(LC 12), 7=-286(LC 13)
 Max Grav 2=1255(LC 1), 7=1255(LC 1)

FORCES. (lb) - Max. Comp./Max. Ten. - All forces 250 (lb) or less except when shown.

TOP CHORD 2-3=-2085/419, 3-4=-1551/360, 4-5=-1320/358, 5-6=-1552/360, 6-7=-2085/419
 BOT CHORD 2-13=-387/1803, 12-13=-387/1804, 10-12=-191/1320, 9-10=-291/1804, 7-9=-291/1803
 WEBS 3-13=0/276, 3-12=-565/225, 4-12=-75/413, 5-10=-67/413, 6-10=-565/226, 6-9=0/276

NOTES-

- Unbalanced roof live loads have been considered for this design.
- Wind: ASCE 7-16; Vult=130mph (3-second gust) Vasd=101mph; TCDL=4.2psf; BCDL=3.0psf; h=20ft; Cat. II; Exp B; Encl., GCpi=0.18; MWFRS (envelope) gable end zone and C-C Exterior(2E) -2-0-0 to 1-1-3, Interior(1) 1-1-3 to 13-0-0, Exterior(2R) 13-0-0 to 17-4-10, Interior(1) 17-4-10 to 18-0-0, Exterior(2R) 18-0-0 to 22-4-10, Interior(1) 22-4-10 to 33-0-0 zone;C-C for members and forces & MWFRS for reactions shown; Lumber DOL=1.60 plate grip DOL=1.60
- Building Designer / Project engineer responsible for verifying applied roof live load shown covers rain loading requirements specific to the use of this truss component.
- Provide adequate drainage to prevent water ponding.
- This truss has been designed for a 10.0 psf bottom chord live load nonconcurrent with any other live loads.
- * This truss has been designed for a live load of 20.0psf on the bottom chord in all areas where a rectangle 3-6-0 tall by 2-0-0 wide will fit between the bottom chord and any other members.
- Provide mechanical connection (by others) of truss to bearing plate capable of withstanding 286 lb uplift at joint 2 and 286 lb uplift at joint 7.

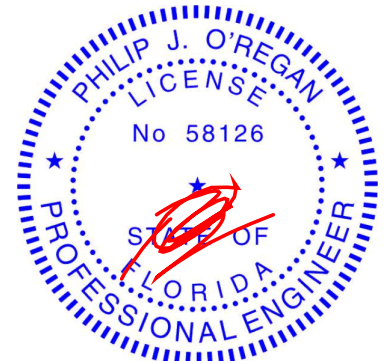

Philip J. O'Regan PE No.58126
 MiTek USA, Inc. FL Cert 6634
 6904 Parke East Blvd. Tampa FL 33610
 Date:

February 11,2022

WARNING - Verify design parameters and READ NOTES ON THIS AND INCLUDED MITEK REFERENCE PAGE MII-7473 rev. 5/19/2020 BEFORE USE.

Design valid for use only with MiTek® connectors. This design is based only upon parameters shown, and is for an individual building component, not a truss system. Before use, the building designer must verify the applicability of design parameters and properly incorporate this design into the overall building design. Bracing indicated is to prevent buckling of individual truss web and/or chord members only. Additional temporary and permanent bracing is always required for stability and to prevent collapse with possible personal injury and property damage. For general guidance regarding the fabrication, storage, delivery, erection and bracing of trusses and truss systems, see

ANSI/TPI1 Quality Criteria, DSB-89 and BCSI Building Component

Safety Information available from Truss Plate Institute, 2670 Crain Highway, Suite 203 Waldorf, MD 20601



6904 Parke East Blvd.
 Tampa, FL 33610

Job 3070916	Truss T05	Truss Type Hip	Qty 1	Ply 1	EVANS - FT WHITE SPEC	T26813923
----------------	--------------	-------------------	----------	----------	-----------------------	-----------

Builders FirstSource (Lake City, FL), Lake City, FL - 32055,

8.430 s Aug 16 2021 MiTek Industries, Inc. Thu Feb 10 16:09:09 2022 Page 1

ID:KlqOOOpJ4Z1Cn3VD1sa2GzOzmc6D-szeyd4ESlg6D4V1wNFG4dLqU2bfJJZGwxPwRmZzmUlu

Job Reference (optional)

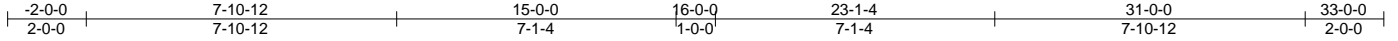

Scale = 1:58.6

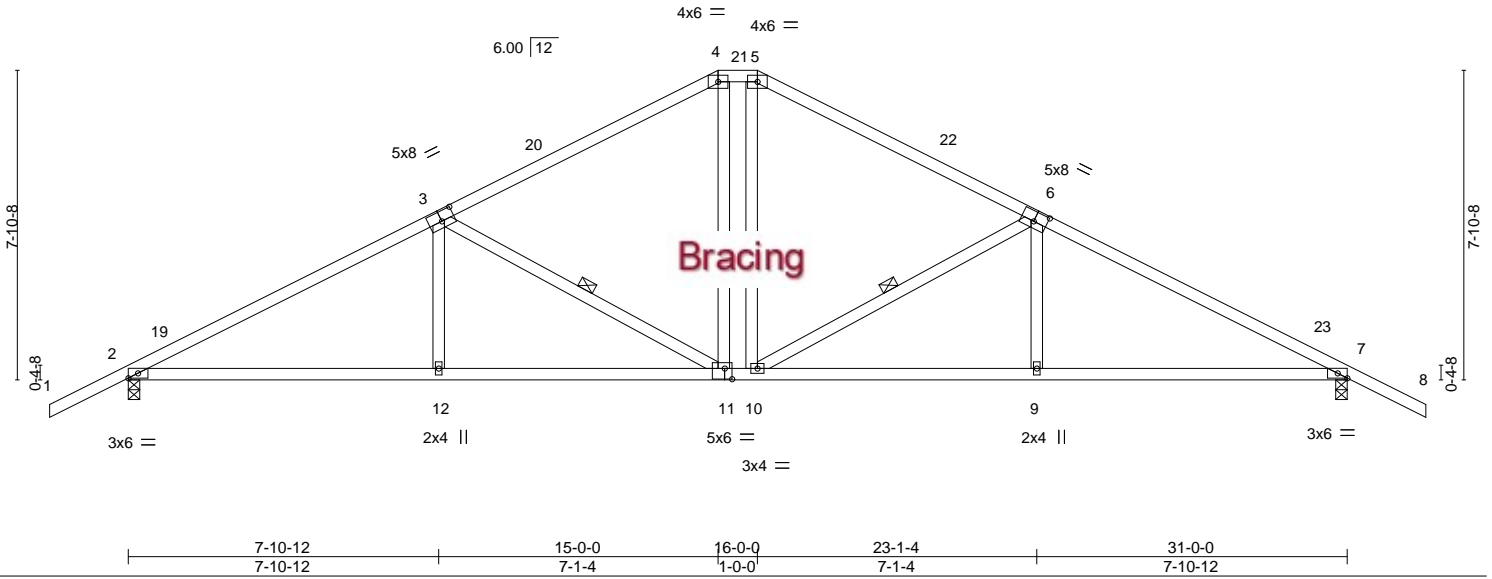

Plate Offsets (X,Y)-- [3:0-4-0,0-3-0], [6:0-4-0,0-3-0], [7:0-2-15,Edge], [11:0-2-4,0-3-4]

LOADING (psf)	SPACING-	CSI.	DEFL.	PLATES	GRIP
TCLL 20.0	2-0-0	TC 0.60	in (loc) l/defl L/d	MT20	244/190
TCDL 7.0	Plate Grip DOL 1.25	BC 0.70	Vert(LL) -0.10 11 >999 240		
BCLL 0.0 *	Lumber DOL 1.25	WB 0.26	Vert(CT) -0.23 9-18 >999 180		
BCDL 10.0	Rep Stress Incr YES	Matrix-MS	Horz(CT) 0.08 7 n/a n/a		
	Code FBC2020/TPI2014			Weight: 161 lb	FT = 20%

LUMBER-

TOP CHORD 2x4 SP No.2
 BOT CHORD 2x4 SP No.2
 WEBS 2x4 SP No.3

BRACING-

TOP CHORD Structural wood sheathing directly applied or 3-4-5 oc purlins.
 BOT CHORD Rigid ceiling directly applied or 9-4-14 oc bracing.
 WEBS 1 Row at midpt 3-11, 6-10

REACTIONS.

(size) 2=0-3-8, 7=0-3-8
 Max Horz 2=127(LC 12)
 Max Uplift 2=-282(LC 12), 7=-282(LC 13)
 Max Grav 2=1255(LC 1), 7=1255(LC 1)

FORCES. (lb) - Max. Comp./Max. Ten. - All forces 250 (lb) or less except when shown.

TOP CHORD 2-3=-2041/403, 3-4=-1407/328, 4-5=-1179/327, 5-6=-1408/328, 6-7=-2041/403
 BOT CHORD 2-12=-377/1754, 11-12=-377/1753, 10-11=-138/1179, 9-10=-256/1753, 7-9=-256/1754
 WEBS 3-12=0/322, 3-11=-688/274, 4-11=-106/401, 5-10=-106/401, 6-10=-688/275, 6-9=0/322

NOTES-

- Unbalanced roof live loads have been considered for this design.
- Wind: ASCE 7-16; Vult=130mph (3-second gust) Vasd=101mph; TCDL=4.2psf; BCDL=3.0psf; h=20ft; Cat. II; Exp B; Encl., GCpi=0.18; MWFRS (envelope) gable end zone and C-C Exterior(2E) -2-0-0 to 1-1-3, Interior(1) 1-1-3 to 15-0-0, Exterior(2E) 15-0-0 to 16-0-0, Exterior(2R) 16-0-0 to 20-4-10, Interior(1) 20-4-10 to 33-0-0 zone; C-C for members and forces & MWFRS for reactions shown; Lumber DOL=1.60 plate grip DOL=1.60
- Building Designer / Project engineer responsible for verifying applied roof live load shown covers rain loading requirements specific to the use of this truss component.
- Provide adequate drainage to prevent water ponding.
- This truss has been designed for a 10.0 psf bottom chord live load nonconcurrent with any other live loads.
- * This truss has been designed for a live load of 20.0psf on the bottom chord in all areas where a rectangle 3-6-0 tall by 2-0-0 wide will fit between the bottom chord and any other members.
- Provide mechanical connection (by others) of truss to bearing plate capable of withstanding 282 lb uplift at joint 2 and 282 lb uplift at joint 7.

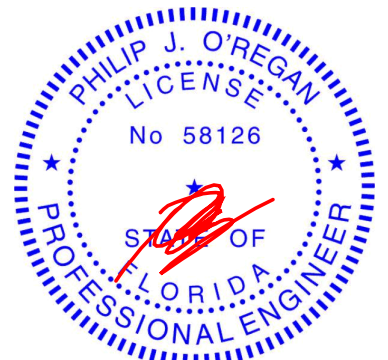

Philip J. O'Regan PE No.58126
 MiTek USA, Inc. FL Cert 6634
 6904 Parke East Blvd. Tampa FL 33610
 Date:

February 11, 2022

WARNING - Verify design parameters and READ NOTES ON THIS AND INCLUDED MITEK REFERENCE PAGE MII-7473 rev. 5/19/2020 BEFORE USE.

Design valid for use only with MiTek® connectors. This design is based only upon parameters shown, and is for an individual building component, not a truss system. Before use, the building designer must verify the applicability of design parameters and properly incorporate this design into the overall building design. Bracing indicated is to prevent buckling of individual truss web and/or chord members only. Additional temporary and permanent bracing is always required for stability and to prevent collapse with possible personal injury and property damage. For general guidance regarding the fabrication, storage, delivery, erection and bracing of trusses and truss systems, see

ANSI/TPI1 Quality Criteria, DSB-89 and BCSI Building Component

Safety Information available from Truss Plate Institute, 2670 Crain Highway, Suite 203 Waldorf, MD 20601



6904 Parke East Blvd.
 Tampa, FL 33610

Job 3070916	Truss T06	Truss Type Common	Qty 3	Ply 1	EVANS - FT WHITE SPEC	T26813924
----------------	--------------	----------------------	----------	----------	-----------------------	-----------

Builders FirstSource (Lake City, FL), Lake City, FL - 32055,

8.430 s Aug 16 2021 MiTek Industries, Inc. Thu Feb 10 16:09:12 2022 Page 1

ID:KlqOOpJ4Z1Cn3VD1sa2GzOzmc6D-GYJ5G6HK1bUoxymV2NqnFzS_Vpg5WvOMdN85NuzmUlr

Job Reference (optional)

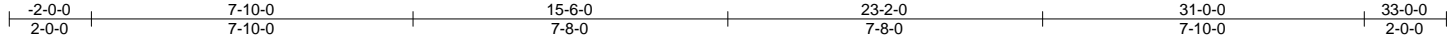

Scale = 1:56.1

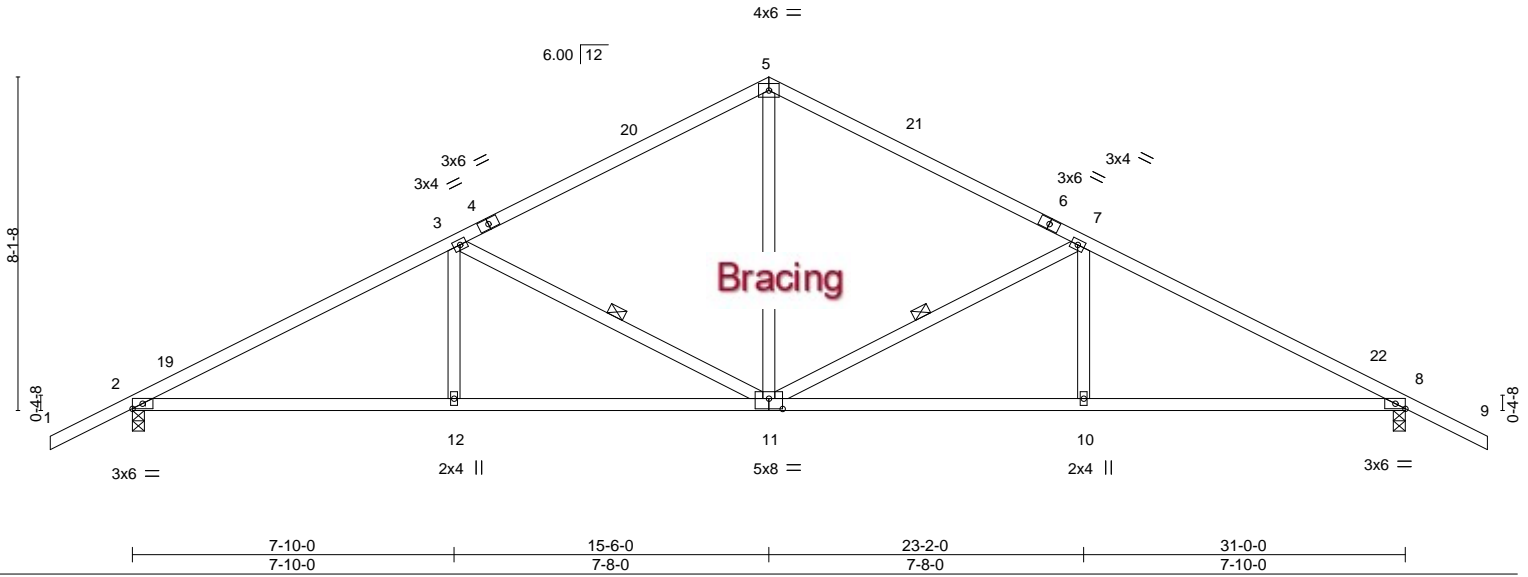

Plate Offsets (X,Y)-- [8:0-2-15,Edge], [11:0-4-0,0-3-0]

LOADING (psf)	SPACING-	CSI.	DEFL.	PLATES	GRIP
TCLL 20.0	Plate Grip DOL 1.25	TC 0.65	in (loc) l/defl L/d	MT20	244/190
TCDL 7.0	Lumber DOL 1.25	BC 0.69	Vert(LL) -0.10 11 >999 240		
BCLL 0.0 *	Rep Stress Incr YES	WB 0.30	Vert(CT) -0.22 10-11 >999 180		
BCDL 10.0	Code FBC2020/TPI2014	Matrix-MS	Horz(CT) 0.08 8 n/a n/a		
				Weight: 152 lb	FT = 20%

LUMBER-

TOP CHORD 2x4 SP No.2
 BOT CHORD 2x4 SP No.2
 WEBS 2x4 SP No.3

BRACING-

TOP CHORD Structural wood sheathing directly applied or 3-5-6 oc purlins.
 BOT CHORD Rigid ceiling directly applied or 9-4-8 oc bracing.
 WEBS 1 Row at midpt 7-11, 3-11

REACTIONS.

(size) 2=0-3-8, 8=0-3-8
 Max Horz 2=130(LC 12)
 Max Uplift 2=-281(LC 12), 8=-281(LC 13)
 Max Grav 2=1255(LC 1), 8=1255(LC 1)

FORCES. (lb) - Max. Comp./Max. Ten. - All forces 250 (lb) or less except when shown.

TOP CHORD 2-3=-2048/402, 3-5=-1391/333, 5-7=-1391/333, 7-8=-2048/403
 BOT CHORD 2-12=-382/1762, 11-12=-382/1762, 10-11=-260/1762, 8-10=-260/1762
 WEBS 5-11=-124/781, 7-11=-703/282, 7-10=0/322, 3-11=-703/282, 3-12=0/322

NOTES-

- Unbalanced roof live loads have been considered for this design.
- Wind: ASCE 7-16; Vult=130mph (3-second gust) Vasd=101mph; TCdL=4.2psf; BCDL=3.0psf; h=20ft; Cat. II; Exp B; Encl., GCpi=0.18; MWFRS (envelope) gable end zone and C-C Exterior(2E) -2-0-0 to 1-1-3, Interior(1) 1-1-3 to 15-6-0, Exterior(2R) 15-6-0 to 18-7-3, Interior(1) 18-7-3 to 33-0-0 zone; C-C for members and forces & MWFRS for reactions shown; Lumber DOL=1.60 plate grip DOL=1.60
- Building Designer / Project engineer responsible for verifying applied roof live load shown covers rain loading requirements specific to the use of this truss component.
- This truss has been designed for a 10.0 psf bottom chord live load nonconcurrent with any other live loads.
- * This truss has been designed for a live load of 20.0psf on the bottom chord in all areas where a rectangle 3-6-0 tall by 2-0-0 wide will fit between the bottom chord and any other members.
- Provide mechanical connection (by others) of truss to bearing plate capable of withstanding 281 lb uplift at joint 2 and 281 lb uplift at joint 8.

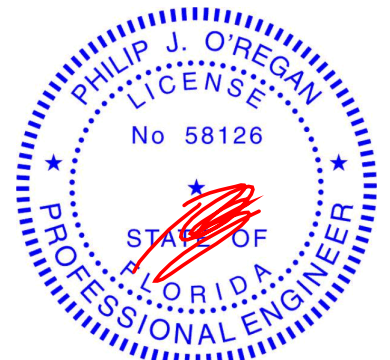

Philip J. O'Regan PE No.58126
 MiTek USA, Inc. FL Cert 6634
 6904 Parke East Blvd. Tampa FL 33610
 Date:

February 11, 2022

WARNING - Verify design parameters and READ NOTES ON THIS AND INCLUDED MITEK REFERENCE PAGE MII-7473 rev. 5/19/2020 BEFORE USE.

Design valid for use only with MiTek® connectors. This design is based only upon parameters shown, and is for an individual building component, not a truss system. Before use, the building designer must verify the applicability of design parameters and properly incorporate this design into the overall building design. Bracing indicated is to prevent buckling of individual truss web and/or chord members only. Additional temporary and permanent bracing is always required for stability and to prevent collapse with possible personal injury and property damage. For general guidance regarding the fabrication, storage, delivery, erection and bracing of trusses and truss systems, see

ANSI/TPI1 Quality Criteria, DSB-89 and BCSI Building Component

Safety Information available from Truss Plate Institute, 2670 Crain Highway, Suite 203 Waldorf, MD 20601



6904 Parke East Blvd.
 Tampa, FL 33610

Job 3070916	Truss T06A	Truss Type Common	Qty 2	Ply 1	EVANS - FT WHITE SPEC	T26813925
----------------	---------------	----------------------	----------	----------	-----------------------	-----------

Builders FirstSource (Lake City, FL), Lake City, FL - 32055,

8.430 s Aug 16 2021 MiTek Industries, Inc. Thu Feb 10 16:09:12 2022 Page 1

ID:KlqOOpJ4Z1Cn3VD1sa2GzOzmc6D-GYJ5G6HK1bUoxymV2NqnFzS_ppg4WscMdN85NuzmUlr

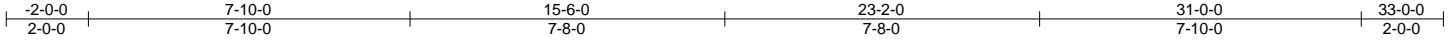

Scale = 1:56.1

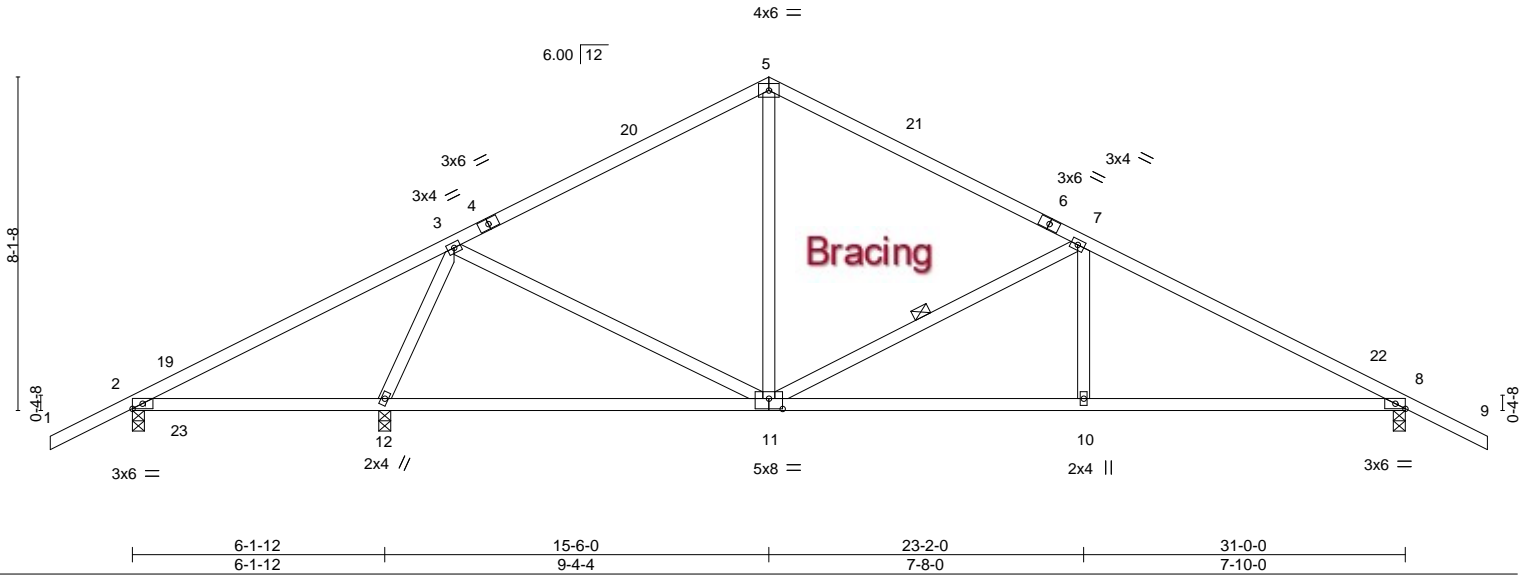

Plate Offsets (X,Y)-- [8:0-2-15,Edge], [11:0-4-0,0-3-0]

LOADING (psf)	SPACING-	CSI.	DEFL.	PLATES	GRIP
TCLL 20.0	Plate Grip DOL 1.25	TC 0.69	in (loc) l/defl L/d	MT20	244/190
TCDL 7.0	Lumber DOL 1.25	BC 0.70	Vert(LL) 0.10 12-15 >736 240		
BCLL 0.0 *	Rep Stress Incr YES	WB 0.48	Vert(CT) -0.30 11-12 >999 180		
BCDL 10.0	Code FBC2020/TPI2014	Matrix-MS	Horz(CT) 0.03 8 n/a n/a		
				Weight: 152 lb	FT = 20%

LUMBER-

TOP CHORD 2x4 SP No.2
 BOT CHORD 2x4 SP No.2
 WEBS 2x4 SP No.3

BRACING-

TOP CHORD Structural wood sheathing directly applied or 4-2-4 oc purlins.
 BOT CHORD Rigid ceiling directly applied or 10-0-0 oc bracing, Except:
 WEBS 6-0-0 oc bracing: 2-12.
 1 Row at midpt 7-11

REACTIONS.

(size) 2=0-3-8, 12=0-3-8, 8=0-3-8
 Max Horz 2=130(LC 12)
 Max Uplift 2=-98(LC 8), 12=-253(LC 12), 8=-252(LC 13)
 Max Grav 2=248(LC 23), 12=1333(LC 1), 8=994(LC 1)

FORCES. (lb) - Max. Comp./Max. Ten. - All forces 250 (lb) or less except when shown.

TOP CHORD 2-3=-77/405, 3-5=-816/245, 5-7=-815/244, 7-8=-1475/340
 BOT CHORD 2-12=-272/157, 10-11=-197/1251, 8-10=-197/1251
 WEBS 3-12=-1230/310, 3-11=-19/494, 5-11=-66/376, 7-11=-704/286, 7-10=0/311

NOTES-

- Unbalanced roof live loads have been considered for this design.
- Wind: ASCE 7-16; Vult=130mph (3-second gust) Vasd=101mph; TCDL=4.2psf; BCDL=3.0psf; h=20ft; Cat. II; Exp B; Encl., GCpi=0.18; MWFRS (envelope) gable end zone and C-C Exterior(2E) -2-0-0 to 1-1-3, Interior(1) 1-1-3 to 15-6-0, Exterior(2R) 15-6-0 to 18-7-3, Interior(1) 18-7-3 to 33-0-0 zone; porch left exposed; C-C for members and forces & MWFRS for reactions shown; Lumber DOL=1.60 plate grip DOL=1.60
- Building Designer / Project engineer responsible for verifying applied roof live load shown covers rain loading requirements specific to the use of this truss component.
- This truss has been designed for a 10.0 psf bottom chord live load nonconcurrent with any other live loads.
- * This truss has been designed for a live load of 20.0psf on the bottom chord in all areas where a rectangle 3-6-0 tall by 2-0-0 wide will fit between the bottom chord and any other members.
- Provide mechanical connection (by others) of truss to bearing plate capable of withstanding 98 lb uplift at joint 2, 253 lb uplift at joint 12 and 252 lb uplift at joint 8.

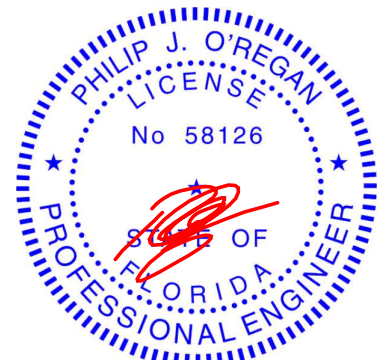

Philip J. O'Regan PE No.58126
 MiTek USA, Inc. FL Cert 6634
 6904 Parke East Blvd. Tampa FL 33610
 Date: February 11, 2022

WARNING - Verify design parameters and READ NOTES ON THIS AND INCLUDED MITEK REFERENCE PAGE MII-7473 rev. 5/19/2020 BEFORE USE.

Design valid for use only with MiTek® connectors. This design is based only upon parameters shown, and is for an individual building component, not a truss system. Before use, the building designer must verify the applicability of design parameters and properly incorporate this design into the overall building design. Bracing indicated is to prevent buckling of individual truss web and/or chord members only. Additional temporary and permanent bracing is always required for stability and to prevent collapse with possible personal injury and property damage. For general guidance regarding the fabrication, storage, delivery, erection and bracing of trusses and truss systems, see

ANSI/TPI1 Quality Criteria, DSB-89 and BCSI Building Component

Safety Information available from Truss Plate Institute, 2670 Crain Highway, Suite 203 Waldorf, MD 20601



6904 Parke East Blvd.
 Tampa, FL 33610

Job	Truss	Truss Type	Qty	Ply	EVANS - FT WHITE SPEC	T26813926
3070916	T07	Roof Special	5	1		

Builders FirstSource (Lake City, FL), Lake City, FL - 32055,

8.430 s Aug 16 2021 MiTek Industries, Inc. Thu Feb 10 16:09:13 2022 Page 1
ID:KlqOOpJ4Z1Cn3VD1sa2GzOzmc6D-klTTSHyovcfZ6Lhc5L0oB?5MD_IFG9Ws1ufvKzmUq

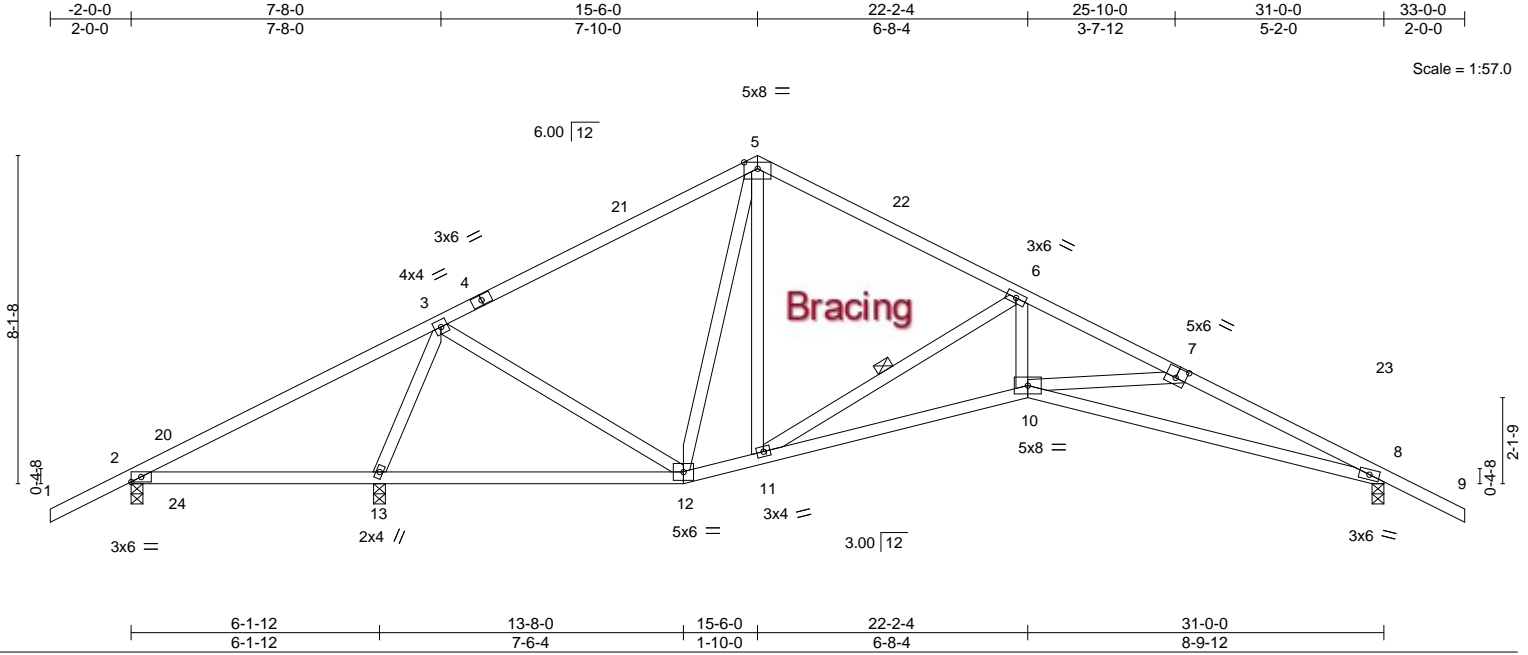

Plate Offsets (X,Y)--	[7:0-3-0,0-3-0]
-----------------------	-----------------

LOADING (psf)	SPACING-	CSI.	DEFL.	PLATES	GRIP
TCLL 20.0	2-0-0	TC 0.90	in (loc) l/defl L/d	MT20	244/190
TCDL 7.0	Plate Grip DOL 1.25	BC 0.80	Vert(LL) -0.17 10-19 >999 240		
BCLL 0.0 *	Lumber DOL 1.25	WB 0.65	Vert(CT) -0.38 10-19 >790 180		
BCDL 10.0	Rep Stress Incr YES	Matrix-MS	Horz(CT) 0.14 8 n/a n/a		
	Code FBC2020/TPI2014			Weight: 164 lb	FT = 20%

LUMBER-	BRACING-
TOP CHORD 2x4 SP No.2	TOP CHORD Structural wood sheathing directly applied or 2-2-0 oc purlins.
BOT CHORD 2x4 SP No.2	BOT CHORD Rigid ceiling directly applied or 5-3-6 oc bracing.
WEBS 2x4 SP No.3	WEBS 1 Row at midpt 6-11

REACTIONS. (size) 2=0-3-8, 8=0-3-8, 13=0-3-8
 Max Horz 2=130(LC 12)
 Max Uplift 2=-360(LC 24), 8=-233(LC 13), 13=-314(LC 12)
 Max Grav 2=41(LC 23), 8=899(LC 1), 13=1813(LC 1)

FORCES. (lb) - Max. Comp./Max. Ten. - All forces 250 (lb) or less except when shown.
 TOP CHORD 2-3=-176/1241, 3-5=-496/194, 5-6=-607/217, 6-7=-2009/387, 7-8=-2345/505
 BOT CHORD 2-13=-1019/303, 12-13=-459/190, 11-12=-15/494, 10-11=-226/1779, 8-10=-375/2123
 WEBS 3-13=-1740/368, 3-12=-94/849, 5-12=-536/58, 5-11=-82/572, 6-11=-1462/344,
 6-10=-115/1108, 7-10=-269/159

- NOTES-**
- 1) Unbalanced roof live loads have been considered for this design.
 - 2) Wind: ASCE 7-16; Vult=130mph (3-second gust) Vasd=101mph; TC DL=4.2psf; BCDL=3.0psf; h=20ft; Cat. II; Exp B; Encl., GCpi=0.18; MWFRS (envelope) gable end zone and C-C Exterior(2E) -2-0-0 to 1-1-3, Interior(1) 1-1-3 to 15-6-0, Exterior(2R) 15-6-0 to 18-7-3, Interior(1) 18-7-3 to 33-0-0 zone; porch left exposed; C-C for members and forces & MWFRS for reactions shown; Lumber DOL=1.60 plate grip DOL=1.60
 - 3) Building Designer / Project engineer responsible for verifying applied roof live load shown covers rain loading requirements specific to the use of this truss component.
 - 4) This truss has been designed for a 10.0 psf bottom chord live load nonconcurrent with any other live loads.
 - 5) * This truss has been designed for a live load of 20.0psf on the bottom chord in all areas where a rectangle 3-6-0 tall by 2-0-0 wide will fit between the bottom chord and any other members.
 - 6) Bearing at joint(s) 8 considers parallel to grain value using ANSI/TPI 1 angle to grain formula. Building designer should verify capacity of bearing surface.
 - 7) Provide mechanical connection (by others) of truss to bearing plate capable of withstanding 360 lb uplift at joint 2, 233 lb uplift at joint 8 and 314 lb uplift at joint 13.

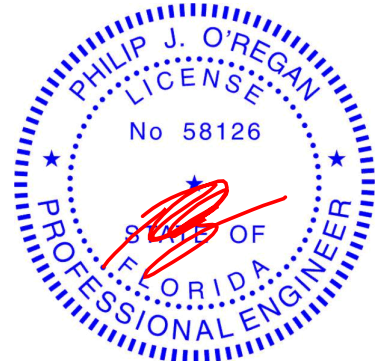

Philip J. O'Regan PE No.58126
 MiTek USA, Inc. FL Cert 6634
 6904 Parke East Blvd. Tampa FL 33610
 Date:

February 11, 2022

WARNING - Verify design parameters and READ NOTES ON THIS AND INCLUDED MITEK REFERENCE PAGE MII-7473 rev. 5/19/2020 BEFORE USE.
 Design valid for use only with MiTek® connectors. This design is based only upon parameters shown, and is for an individual building component, not a truss system. Before use, the building designer must verify the applicability of design parameters and properly incorporate this design into the overall building design. Bracing indicated is to prevent buckling of individual truss web and/or chord members only. Additional temporary and permanent bracing is always required for stability and to prevent collapse with possible personal injury and property damage. For general guidance regarding the fabrication, storage, delivery, erection and bracing of trusses and truss systems, see **ANSI/TPI1 Quality Criteria, DSB-89 and BCSI Building Component Safety Information** available from Truss Plate Institute, 2670 Crain Highway, Suite 203 Waldorf, MD 20601



6904 Parke East Blvd.
 Tampa, FL 33610

Job 3070916	Truss T08	Truss Type Roof Special	Qty 1	Ply 1	EVANS - FT WHITE SPEC Job Reference (optional)	T26813927
----------------	--------------	----------------------------	----------	----------	---	-----------

Builders FirstSource (Lake City,FL), Lake City, FL - 32055,

8.430 s Aug 16 2021 MiTek Industries, Inc. Thu Feb 10 16:09:14 2022 Page 1

ID:KlqOOpJ4Z1Cn3VD1sa2GzOzmc6D-CxRrhnbZDkWAGwuAosFKOXlqcNo_fIN4gdCRnzmUlp

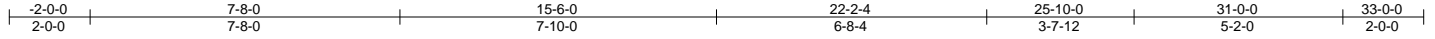

Scale = 1:57.0

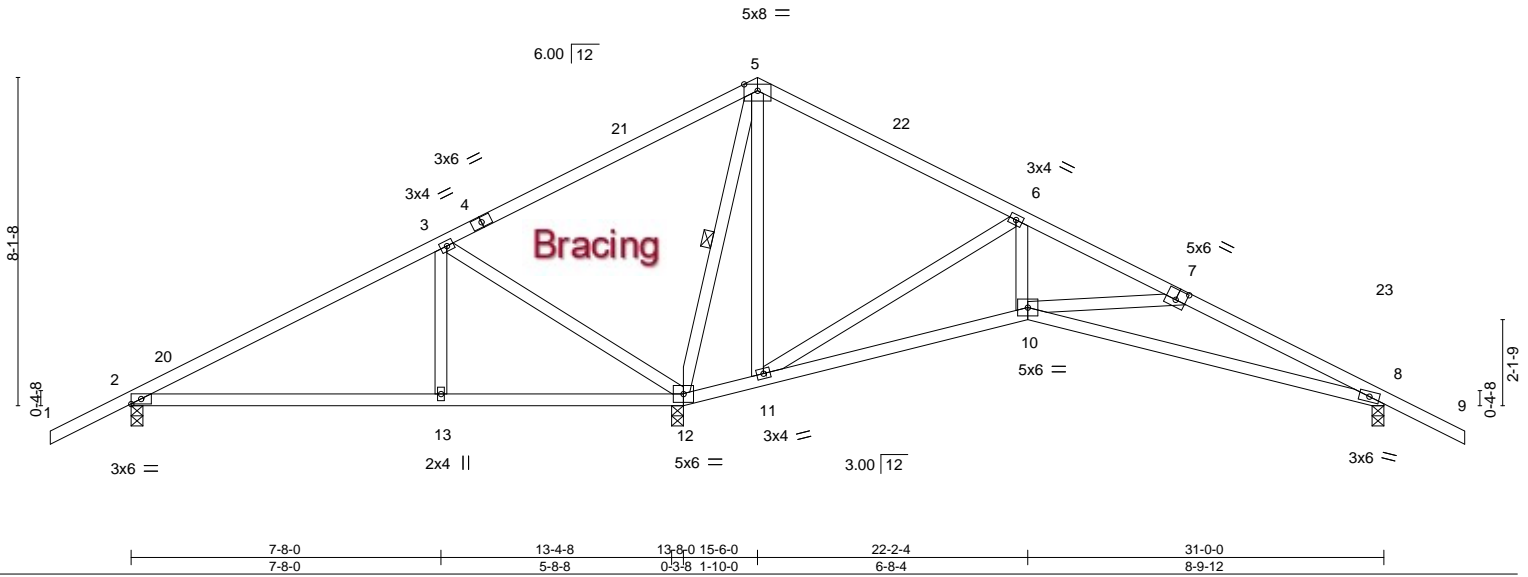

Plate Offsets (X,Y)-- [7:0-3-0,0-3-0]

LOADING (psf)	SPACING-	CSI.	DEFL.	PLATES	GRIP
TCLL 20.0	2-0-0	TC 0.79	in (loc) l/defl L/d	MT20	244/190
TCDL 7.0	Plate Grip DOL 1.25	BC 0.62	Vert(LL) -0.15 10-19 >999 240		
BCLL 0.0 *	Lumber DOL 1.25	WB 0.91	Vert(CT) -0.31 10-19 >681 180		
BCDL 10.0	Rep Stress Incr YES	Matrix-MS	Horz(CT) 0.04 8 n/a n/a		
	Code FBC2020/TPI2014			Weight: 163 lb	FT = 20%

LUMBER-

TOP CHORD 2x4 SP No.2
 BOT CHORD 2x4 SP No.2
 WEBS 2x4 SP No.3

BRACING-

TOP CHORD Structural wood sheathing directly applied or 5-11-4 oc purlins.
 BOT CHORD Rigid ceiling directly applied or 6-0-0 oc bracing.
 WEBS 1 Row at midpt 5-12

REACTIONS.

(size) 2=0-3-8, 12=0-3-8, 8=0-3-8
 Max Horz 2=130(LC 12)
 Max Uplift 2=-129(LC 12), 12=-273(LC 12), 8=-165(LC 13)
 Max Grav 2=461(LC 23), 12=1696(LC 1), 8=523(LC 24)

FORCES. (lb) - Max. Comp./Max. Ten. - All forces 250 (lb) or less except when shown.

TOP CHORD 2-3=-324/389, 3-5=-50/795, 5-6=-11/477, 6-7=-459/104, 7-8=-842/235
 BOT CHORD 2-13=-321/228, 12-13=-321/228, 11-12=-370/254, 10-11=0/379, 8-10=-130/763
 WEBS 3-13=0/317, 3-12=-673/272, 5-12=-1224/173, 5-11=-34/396, 6-11=-807/222, 6-10=0/511,
 7-10=-360/175

NOTES-

- Unbalanced roof live loads have been considered for this design.
- Wind: ASCE 7-16; Vult=130mph (3-second gust) Vasd=101mph; TC DL=4.2psf; BCDL=3.0psf; h=20ft; Cat. II; Exp B; Encl., GCpi=0.18; MWFRS (envelope) gable end zone and C-C Exterior(2E) -2-0-0 to 1-1-3, Interior(1) 1-1-3 to 15-6-0, Exterior(2R) 15-6-0 to 18-7-3, Interior(1) 18-7-3 to 33-0-0 zone; C-C for members and forces & MWFRS for reactions shown; Lumber DOL=1.60 plate grip DOL=1.60
- Building Designer / Project engineer responsible for verifying applied roof live load shown covers rain loading requirements specific to the use of this truss component.
- This truss has been designed for a 10.0 psf bottom chord live load nonconcurrent with any other live loads.
- * This truss has been designed for a live load of 20.0psf on the bottom chord in all areas where a rectangle 3-6-0 tall by 2-0-0 wide will fit between the bottom chord and any other members.
- Bearing at joint(s) 8 considers parallel to grain value using ANSI/TPI 1 angle to grain formula. Building designer should verify capacity of bearing surface.
- Provide mechanical connection (by others) of truss to bearing plate capable of withstanding 129 lb uplift at joint 2, 273 lb uplift at joint 12 and 165 lb uplift at joint 8.

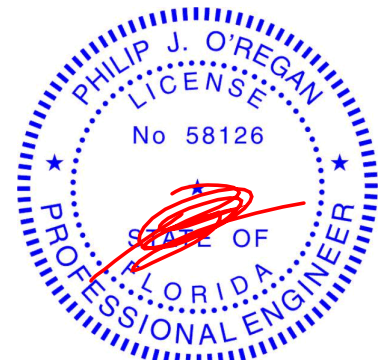

Philip J. O'Regan PE No.58126
 MiTek USA, Inc. FL Cert 6634
 6904 Parke East Blvd. Tampa FL 33610
 Date:

February 11, 2022

WARNING - Verify design parameters and READ NOTES ON THIS AND INCLUDED MITEK REFERENCE PAGE MII-7473 rev. 5/19/2020 BEFORE USE.

Design valid for use only with MiTek® connectors. This design is based only upon parameters shown, and is for an individual building component, not a truss system. Before use, the building designer must verify the applicability of design parameters and properly incorporate this design into the overall building design. Bracing indicated is to prevent buckling of individual truss web and/or chord members only. Additional temporary and permanent bracing is always required for stability and to prevent collapse with possible personal injury and property damage. For general guidance regarding the fabrication, storage, delivery, erection and bracing of trusses and truss systems, see

ANSI/TPI1 Quality Criteria, DSB-89 and BCSI Building Component

Safety Information available from Truss Plate Institute, 2670 Crain Highway, Suite 203 Waldorf, MD 20601



6904 Parke East Blvd.
 Tampa, FL 33610

Job	Truss	Truss Type	Qty	Ply	EVANS - FT WHITE SPEC	T26813928
3070916	T09	Hip Girder	1	1		

Builders FirstSource (Lake City, FL), Lake City, FL - 32055, 8.430 s Aug 16 2021 MiTek Industries, Inc. Thu Feb 10 16:09:16 2022 Page 1

ID:KlqOOpJ4Z1Cn3VD1sa2GzOzmc6D-9KZb5TKr5q_DQZ3GHUjQpdh4Q5fSiPyY_6JWfzmUln

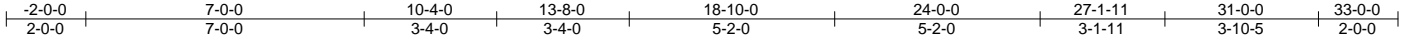

Scale = 1:57.9

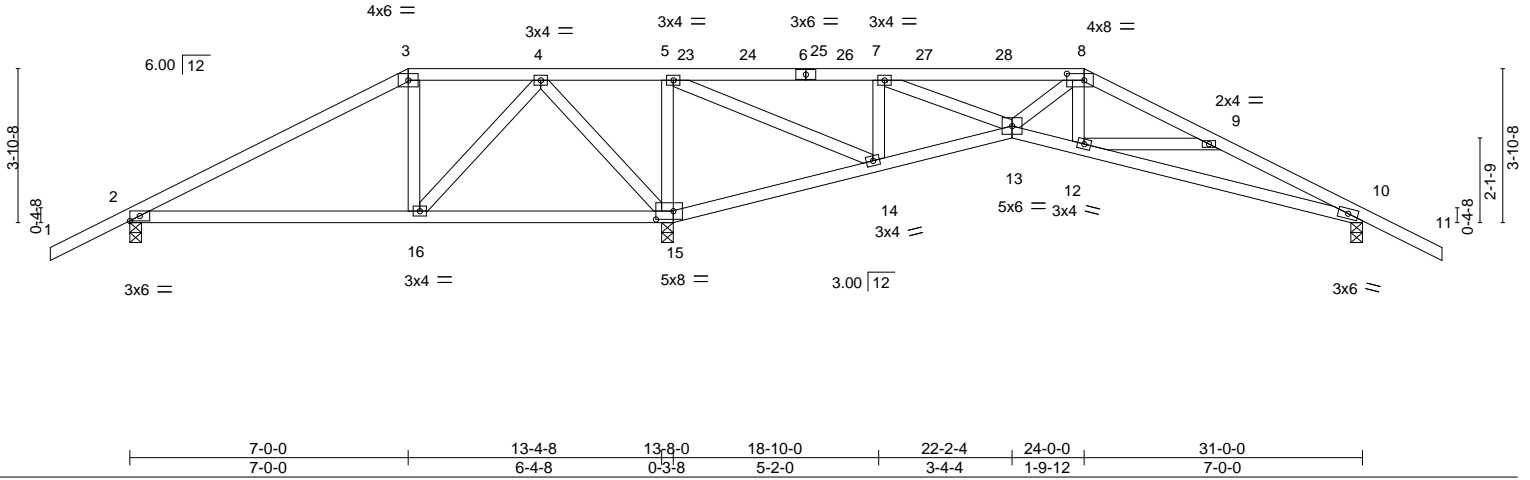

Plate Offsets (X,Y)--	[8:0-5-4,0-2-0], [15:0-5-4,0-2-8]
-----------------------	-----------------------------------

LOADING (psf)	SPACING-	CSI.	DEFL.	PLATES	GRIP
TCLL 20.0	Plate Grip DOL 1.25	TC 0.55	in (loc) l/defl L/d	MT20	244/190
TCDL 7.0	Lumber DOL 1.25	BC 0.46	Vert(LL) 0.06 16-19 >999 240		
BCLL 0.0 *	Rep Stress Incr NO	WB 0.36	Vert(CT) -0.12 16-19 >999 180		
BCDL 10.0	Code FBC2020/TPI2014	Matrix-MS	Horz(CT) 0.03 10 n/a n/a		
				Weight: 152 lb	FT = 20%

LUMBER-	BRACING-
TOP CHORD 2x4 SP No.2	TOP CHORD Structural wood sheathing directly applied or 5-9-11 oc purlins.
BOT CHORD 2x4 SP No.2	BOT CHORD Rigid ceiling directly applied or 5-11-12 oc bracing.
WEBS 2x4 SP No.3	

REACTIONS. (size) 2=0-3-8, 15=0-3-8, 10=0-3-8
 Max Horz 2=-67(LC 9)
 Max Uplift 2=-184(LC 34), 15=-402(LC 4), 10=-190(LC 9)
 Max Grav 2=426(LC 26), 15=1491(LC 1), 10=532(LC 20)

FORCES. (lb) - Max. Comp./Max. Ten. - All forces 250 (lb) or less except when shown.
 TOP CHORD 4-5=-177/890, 7-8=-492/206, 8-9=-695/240, 9-10=-1022/368
 BOT CHORD 15-16=-405/253, 14-15=-954/348, 12-13=-99/616, 10-12=-263/923
 WEBS 3-16=-265/103, 4-16=-102/597, 4-15=-785/182, 5-15=-588/256, 5-14=-312/933,
 7-14=-484/226, 7-13=-112/585, 8-12=-11/285, 9-12=-296/185

- NOTES-**
- 1) Unbalanced roof live loads have been considered for this design.
 - 2) Wind: ASCE 7-16; Vult=130mph (3-second gust) Vasd=101mph; TCDL=4.2psf; BCDL=3.0psf; h=20ft; Cat. II; Exp B; Encl., GCpi=0.18; MWFRS (envelope) gable end zone; Lumber DOL=1.60 plate grip DOL=1.60
 - 3) Building Designer / Project engineer responsible for verifying applied roof live load shown covers rain loading requirements specific to the use of this truss component.
 - 4) Provide adequate drainage to prevent water ponding.
 - 5) This truss has been designed for a 10.0 psf bottom chord live load nonconcurrent with any other live loads.
 - 6) * This truss has been designed for a live load of 20.0psf on the bottom chord in all areas where a rectangle 3-6-0 tall by 2-0-0 wide will fit between the bottom chord and any other members.
 - 7) Bearing at joint(s) 10 considers parallel to grain value using ANSI/TPI 1 angle to grain formula. Building designer should verify capacity of bearing surface.
 - 8) Provide mechanical connection (by others) of truss to bearing plate capable of withstanding 184 lb uplift at joint 2, 402 lb uplift at joint 15 and 190 lb uplift at joint 10.
 - 9) Hanger(s) or other connection device(s) shall be provided sufficient to support concentrated load(s) 31 lb down and 24 lb up at 13-11-4, 31 lb down and 24 lb up at 15-11-4, 31 lb down and 24 lb up at 17-11-4, 31 lb down and 24 lb up at 19-11-4, and 31 lb down and 24 lb up at 21-11-4, and 44 lb down and 37 lb up at 24-0-0 on top chord. The design/selection of such connection device(s) is the responsibility of others.
 - 10) In the LOAD CASE(S) section, loads applied to the face of the truss are noted as front (F) or back (B).

LOAD CASE(S) Standard
 1) Dead + Roof Live (balanced): Lumber Increase=1.25, Plate Increase=1.25
 Uniform Loads (plf)
 Vert: 1-3=-54, 3-8=-54, 8-11=-54, 15-17=-20, 13-15=-20, 13-20=-20

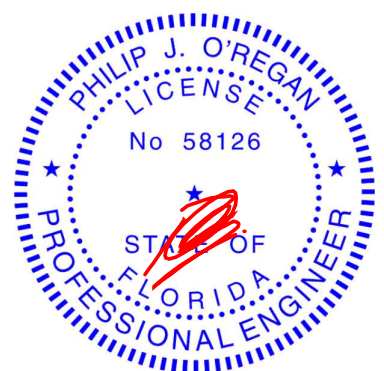

Philip J. O'Regan PE No.58126
 MiTek USA, Inc. FL Cert 6634
 6904 Parke East Blvd. Tampa FL 33610
 Date: February 11, 2022

Continued on page 2

WARNING - Verify design parameters and READ NOTES ON THIS AND INCLUDED MITEK REFERENCE PAGE MII-7473 rev. 5/19/2020 BEFORE USE.
 Design valid for use only with MiTek® connectors. This design is based only upon parameters shown, and is for an individual building component, not a truss system. Before use, the building designer must verify the applicability of design parameters and properly incorporate this design into the overall building design. Bracing indicated is to prevent buckling of individual truss web and/or chord members only. Additional temporary and permanent bracing is always required for stability and to prevent collapse with possible personal injury and property damage. For general guidance regarding the fabrication, storage, delivery, erection and bracing of trusses and truss systems, see **ANSI/TPI1 Quality Criteria, DSB-89 and BCSI Building Component Safety Information** available from Truss Plate Institute, 2670 Crain Highway, Suite 203 Waldorf, MD 20601

6904 Parke East Blvd.
 Tampa, FL 33610

Job	Truss	Truss Type	Qty	Ply	EVANS - FT WHITE SPEC	T26813928
3070916	T09	Hip Girder	1	1	Job Reference (optional)	

Builders FirstSource (Lake City,FL), Lake City, FL - 32055,

8.430 s Aug 16 2021 MiTek Industries, Inc. Thu Feb 10 16:09:16 2022 Page 2
ID:KlqOOpJ4Z1Cn3VD1sa2GzOzmc6D-9KZb5TKr5q_DQZ3GHDujQpdh4Q5fSiPyY_6JWfzmUln

LOAD CASE(S) Standard

Concentrated Loads (lb)

Vert: 8=19(B) 23=19(B) 25=19(B) 26=19(B) 27=19(B) 28=19(B)

WARNING - Verify design parameters and READ NOTES ON THIS AND INCLUDED MITEK REFERENCE PAGE MII-7473 rev. 5/19/2020 BEFORE USE.

Design valid for use only with MiTek® connectors. This design is based only upon parameters shown, and is for an individual building component, not a truss system. Before use, the building designer must verify the applicability of design parameters and properly incorporate this design into the overall building design. Bracing indicated is to prevent buckling of individual truss web and/or chord members only. Additional temporary and permanent bracing is always required for stability and to prevent collapse with possible personal injury and property damage. For general guidance regarding the fabrication, storage, delivery, erection and bracing of trusses and truss systems, see **ANSI/TPI1 Quality Criteria, DSB-89 and BCSI Building Component Safety Information** available from Truss Plate Institute, 2670 Crain Highway, Suite 203 Waldorf, MD 20601



6904 Parke East Blvd.
Tampa, FL 36610

Job 3070916	Truss T11	Truss Type Hip	Qty 1	Ply 1	EVANS - FT WHITE SPEC	T26813930
----------------	--------------	-------------------	----------	----------	-----------------------	-----------

Builders FirstSource (Lake City, FL), Lake City, FL - 32055, 8.430 s Aug 16 2021 MiTek Industries, Inc. Thu Feb 10 16:09:27 2022 Page 1

ID:KlqOOpJ4Z1Cn3VD1sa2GzOzmc6D-KRjmPESkVCNgEGPNR1bIM8ac?spZXela4CHOPXzmUlc

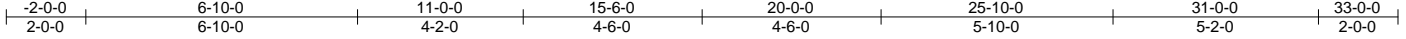

Scale = 1:57.9

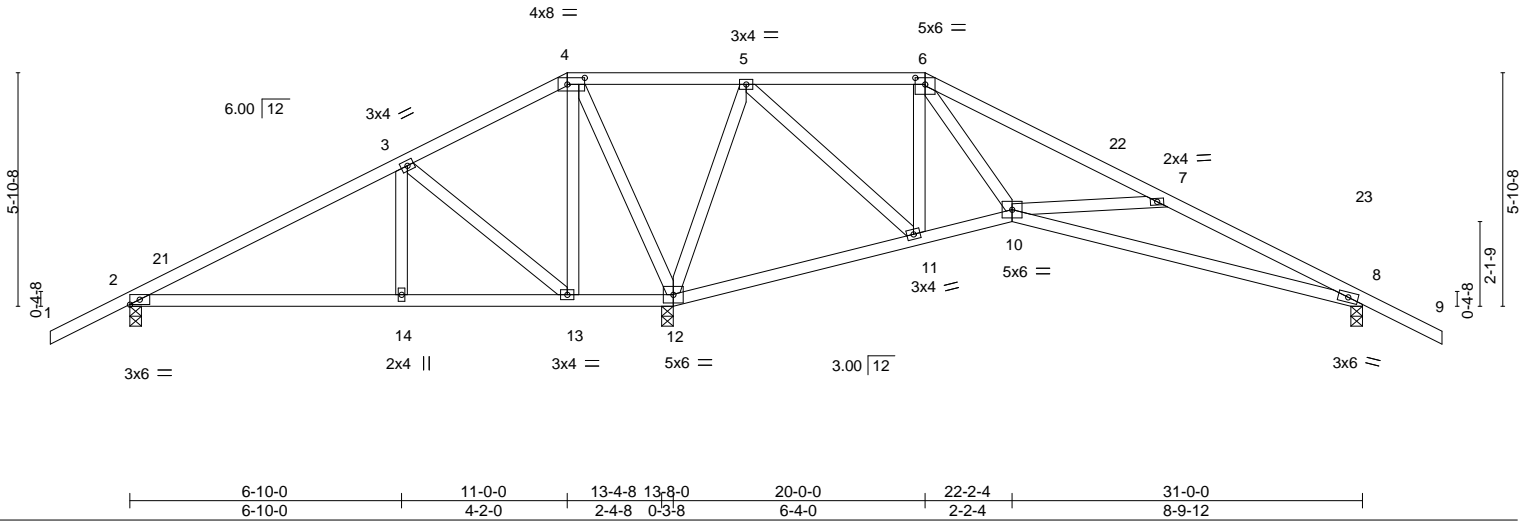

Plate Offsets (X,Y)-- [4:0-5-4,0-2-0], [6:0-3-0,0-2-0]

LOADING (psf)	SPACING-	CSI.	DEFL.	PLATES	GRIP
TCLL 20.0	Plate Grip DOL 1.25	TC 0.44	in (loc) l/defl L/d	MT20	244/190
TCDL 7.0	Lumber DOL 1.25	BC 0.63	Vert(LL) -0.15 10-20 >999 240		
BCLL 0.0 *	Rep Stress Incr YES	WB 0.58	Vert(CT) -0.30 10-20 >693 180		
BCDL 10.0	Code FBC2020/TPI2014	Matrix-MS	Horz(CT) 0.03 8 n/a n/a		
				Weight: 167 lb	FT = 20%

LUMBER-
 TOP CHORD 2x4 SP No.2
 BOT CHORD 2x4 SP No.2
 WEBS 2x4 SP No.3

BRACING-
 TOP CHORD Structural wood sheathing directly applied or 5-7-13 oc purlins.
 BOT CHORD Rigid ceiling directly applied or 6-0-0 oc bracing.

REACTIONS. (size) 2=0-3-8, 12=0-3-8, 8=0-3-8
 Max Horz 2=-97(LC 13)
 Max Uplift 2=-140(LC 12), 12=-277(LC 13), 8=-166(LC 13)
 Max Grav 2=435(LC 23), 12=1680(LC 1), 8=531(LC 24)

FORCES. (lb) - Max. Comp./Max. Ten. - All forces 250 (lb) or less except when shown.
 TOP CHORD 2-3=-287/330, 3-4=-57/517, 4-5=-64/751, 6-7=-395/53, 7-8=-969/302
 BOT CHORD 2-14=-272/195, 13-14=-272/195, 12-13=-448/246, 11-12=-542/241, 8-10=-200/891
 WEBS 3-14=0/268, 3-13=-490/184, 4-13=-91/329, 4-12=-795/185, 5-12=-768/174,
 5-11=-118/675, 6-11=-495/129, 6-10=-12/446, 7-10=-572/321

- NOTES-**
- Unbalanced roof live loads have been considered for this design.
 - Wind: ASCE 7-16; Vult=130mph (3-second gust) Vasd=101mph; TC DL=4.2psf; BCDL=3.0psf; h=20ft; Cat. II; Exp B; Encl., GCpi=0.18; MWFRS (envelope) gable end zone and C-C Exterior(2E) -2-0-0 to 1-1-3, Interior(1) 1-1-3 to 11-0-0, Exterior(2R) 11-0-0 to 15-6-0, Interior(1) 15-6-0 to 20-0-0, Exterior(2R) 20-0-0 to 24-4-10, Interior(1) 24-4-10 to 33-0-0 zone; C-C for members and forces & MWFRS for reactions shown; Lumber DOL=1.60 plate grip DOL=1.60
 - Building Designer / Project engineer responsible for verifying applied roof live load shown covers rain loading requirements specific to the use of this truss component.
 - Provide adequate drainage to prevent water ponding.
 - This truss has been designed for a 10.0 psf bottom chord live load nonconcurrent with any other live loads.
 - * This truss has been designed for a live load of 20.0psf on the bottom chord in all areas where a rectangle 3-6-0 tall by 2-0-0 wide will fit between the bottom chord and any other members.
 - Bearing at joint(s) 8 considers parallel to grain value using ANSI/TPI 1 angle to grain formula. Building designer should verify capacity of bearing surface.
 - Provide mechanical connection (by others) of truss to bearing plate capable of withstanding 140 lb uplift at joint 2, 277 lb uplift at joint 12 and 166 lb uplift at joint 8.

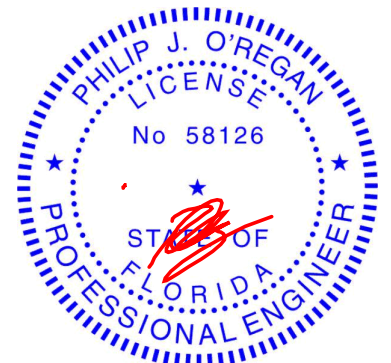

Philip J. O'Regan PE No.58126
 MiTek USA, Inc. FL Cert 6634
 6904 Parke East Blvd. Tampa FL 33610
 Date:

February 11, 2022

WARNING - Verify design parameters and READ NOTES ON THIS AND INCLUDED MITEK REFERENCE PAGE MII-7473 rev. 5/19/2020 BEFORE USE.

Design valid for use only with MiTek® connectors. This design is based only upon parameters shown, and is for an individual building component, not a truss system. Before use, the building designer must verify the applicability of design parameters and properly incorporate this design into the overall building design. Bracing indicated is to prevent buckling of individual truss web and/or chord members only. Additional temporary and permanent bracing is always required for stability and to prevent collapse with possible personal injury and property damage. For general guidance regarding the fabrication, storage, delivery, erection and bracing of trusses and truss systems, see

ANSI/TPI1 Quality Criteria, DSB-89 and BCSI Building Component

Safety Information available from Truss Plate Institute, 2670 Crain Highway, Suite 203 Waldorf, MD 20601



6904 Parke East Blvd.
 Tampa, FL 33610

Job	Truss	Truss Type	Qty	Ply	EVANS - FT WHITE SPEC	T26813931
3070916	T12	Hip	1	1		

Builders FirstSource (Lake City,FL), Lake City, FL - 32055,

8.430 s Aug 16 2021 MiTek Industries, Inc. Thu Feb 10 16:09:36 2022 Page 1

ID:KlqOOpJ4Z1Cn3VD1sa2GzOzmc6D-ZAm9lJZOozWOp66SQFPE1S6xUti8c3v86yNDVzmUIT

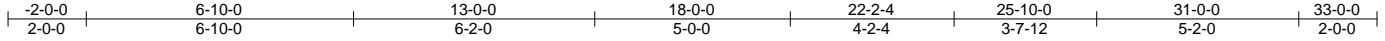

Scale = 1:58.9

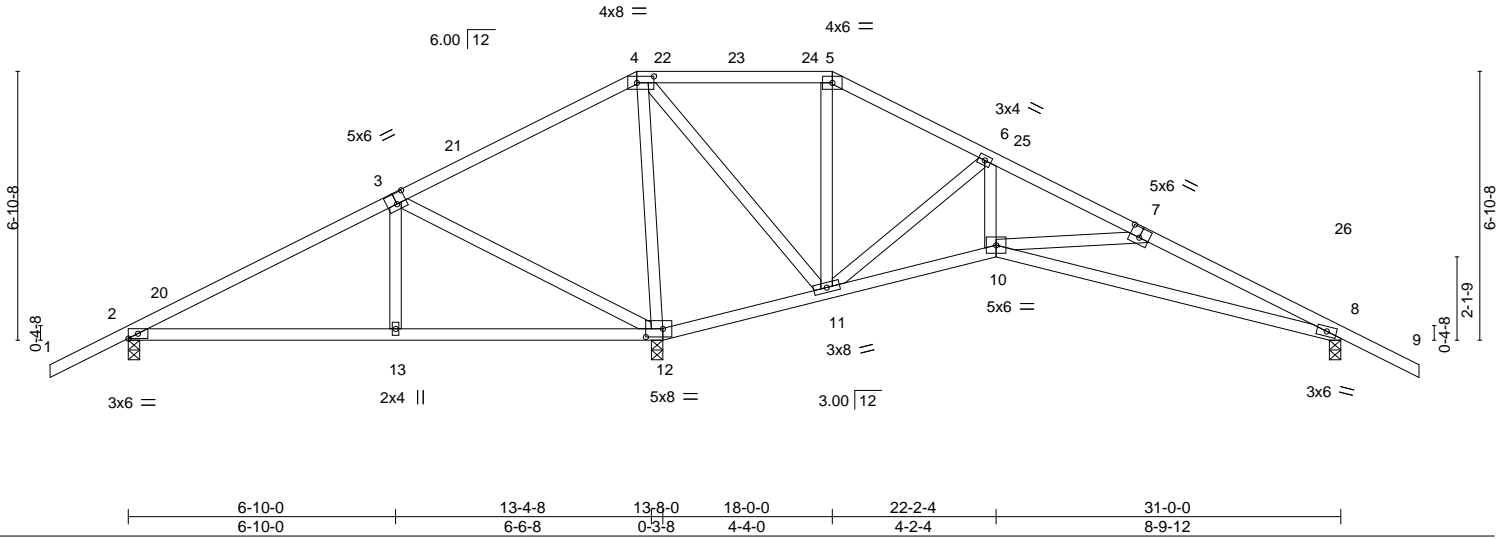

Plate Offsets (X,Y)--	[3:0-3-0,0-3-4], [4:0-5-4,0-2-0], [7:0-3-0,0-3-0], [12:0-5-4,0-2-8]
-----------------------	---

LOADING (psf)	SPACING-	CSI.	DEFL.	PLATES	GRIP
TCLL 20.0	Plate Grip DOL 1.25	TC 0.55	in (loc) l/defl L/d	MT20	244/190
TCDL 7.0	Lumber DOL 1.25	BC 0.63	Vert(LL) -0.15 10-19 >999 240		
BCLL 0.0 *	Rep Stress Incr YES	WB 0.95	Vert(CT) -0.31 10-19 >675 180		
BCDL 10.0	Code FBC2020/TPI2014	Matrix-MS	Horz(CT) 0.03 8 n/a n/a		
				Weight: 164 lb	FT = 20%

LUMBER-	BRACING-
TOP CHORD 2x4 SP No.2	TOP CHORD Structural wood sheathing directly applied or 5-9-2 oc purlins.
BOT CHORD 2x4 SP No.2	BOT CHORD Rigid ceiling directly applied or 6-0-0 oc bracing.
WEBS 2x4 SP No.3	

REACTIONS. (size) 2=0-3-8, 8=0-3-8, 12=0-3-8
 Max Horz 2=-112(LC 13)
 Max Uplift 2=-136(LC 12), 8=-171(LC 13), 12=-267(LC 12)
 Max Grav 2=450(LC 23), 8=536(LC 24), 12=1678(LC 1)

FORCES. (lb) - Max. Comp./Max. Ten. - All forces 250 (lb) or less except when shown.
 TOP CHORD 2-3=-336/328, 3-4=-48/702, 5-6=0/260, 6-7=-476/107, 7-8=-913/268
 BOT CHORD 2-13=-270/243, 12-13=-269/244, 11-12=-716/287, 10-11=0/376, 8-10=-161/830
 WEBS 3-13=0/312, 3-12=-621/232, 4-12=-1130/220, 4-11=-140/738, 5-11=-333/83,
 6-11=-638/157, 6-10=-14/480, 7-10=-414/211

- NOTES-**
- Unbalanced roof live loads have been considered for this design.
 - Wind: ASCE 7-16; Vult=130mph (3-second gust) Vasd=101mph; TC DL=4.2psf; BCDL=3.0psf; h=20ft; Cat. II; Exp B; Encl., GCpi=0.18; MWFRS (envelope) gable end zone and C-C Exterior(2E) -2-0-0 to 1-1-3, Interior(1) 1-1-3 to 13-0-0, Exterior(2R) 13-0-0 to 17-4-10, Interior(1) 17-4-10 to 18-0-0, Exterior(2R) 18-0-0 to 22-4-10, Interior(1) 22-4-10 to 33-0-0 zone; C-C for members and forces & MWFRS for reactions shown; Lumber DOL=1.60 plate grip DOL=1.60
 - Building Designer / Project engineer responsible for verifying applied roof live load shown covers rain loading requirements specific to the use of this truss component.
 - Provide adequate drainage to prevent water ponding.
 - This truss has been designed for a 10.0 psf bottom chord live load nonconcurrent with any other live loads.
 - * This truss has been designed for a live load of 20.0psf on the bottom chord in all areas where a rectangle 3-6-0 tall by 2-0-0 wide will fit between the bottom chord and any other members.
 - Bearing at joint(s) 8 considers parallel to grain value using ANSI/TPI 1 angle to grain formula. Building designer should verify capacity of bearing surface.
 - Provide mechanical connection (by others) of truss to bearing plate capable of withstanding 136 lb uplift at joint 2, 171 lb uplift at joint 8 and 267 lb uplift at joint 12.

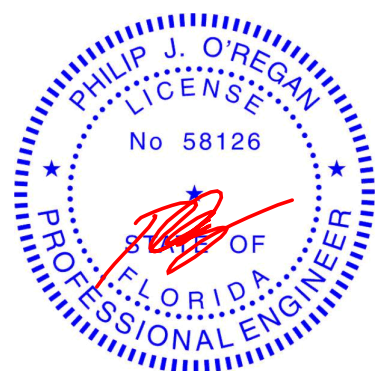

Philip J. O'Regan PE No.58126
 MiTek USA, Inc. FL Cert 6634
 6904 Parke East Blvd. Tampa FL 33610
 Date: February 11, 2022

Job	Truss	Truss Type	Qty	Ply	EVANS - FT WHITE SPEC	T26813933
3070916	T14	Common	3	1		

Builders FirstSource (Lake City,FL), Lake City, FL - 32055,

8.430 s Aug 16 2021 MiTek Industries, Inc. Thu Feb 10 16:09:41 2022 Page 1
ID:KlqOOpJ4Z1Cn3VD1sa2GzOzmc6D-w7a2L0dXCW8gwPU4Fzraw59z3VdCp4LeINg7ujzmUIO



Scale = 1:26.1

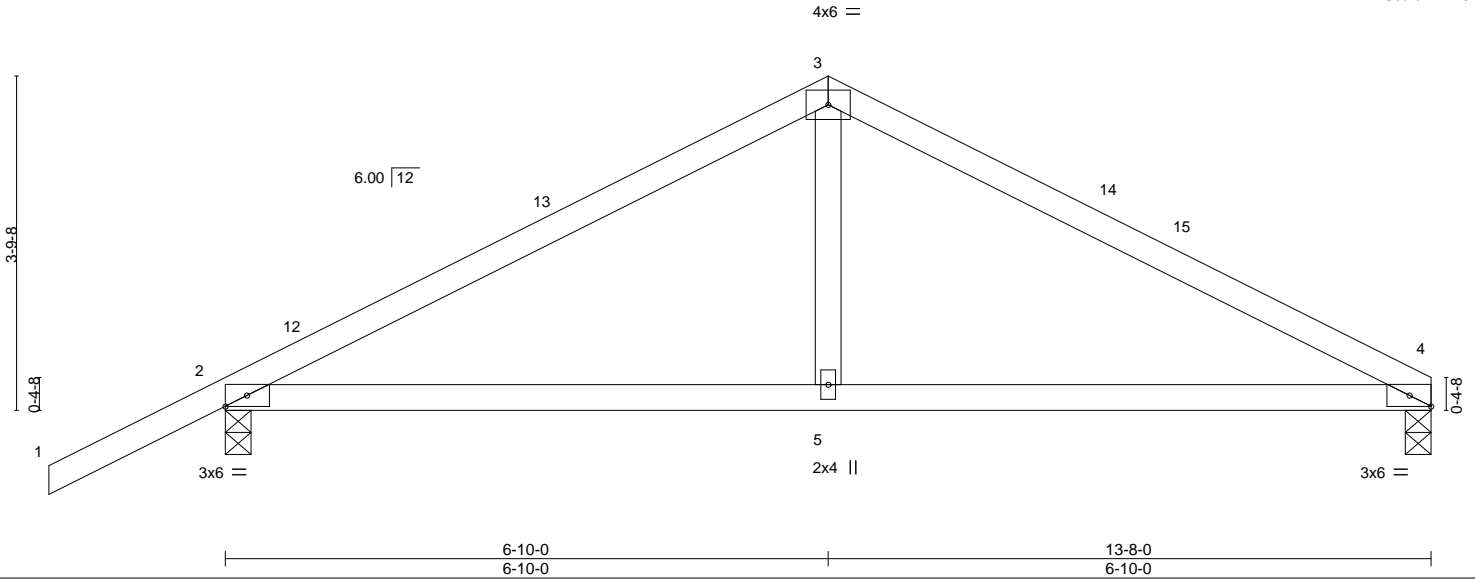

Plate Offsets (X,Y)-- [4:0-2-15,Edge]

LOADING (psf)	SPACING-	CSL.	DEFL.	in	(loc)	I/defl	L/d	PLATES	GRIP
TCLL 20.0	Plate Grip DOL 1.25	TC 0.53	Vert(LL)	-0.08	5-8	>999	240	MT20	244/190
TCDL 7.0	Lumber DOL 1.25	BC 0.48	Vert(CT)	-0.14	5-8	>999	180		
BCLL 0.0 *	Rep Stress Incr YES	WB 0.12	Horz(CT)	0.01	4	n/a	n/a		
BCDL 10.0	Code FBC2020/TPI2014	Matrix-MS						Weight: 52 lb	FT = 20%

LUMBER-

TOP CHORD 2x4 SP No.2
BOT CHORD 2x4 SP No.2
WEBS 2x4 SP No.3

BRACING-

TOP CHORD Structural wood sheathing directly applied or 5-9-0 oc purlins.
BOT CHORD Rigid ceiling directly applied or 10-0-0 oc bracing.

REACTIONS.

(size) 4=0-3-8, 2=0-3-8
Max Horz 2=80(LC 16)
Max Uplift 4=103(LC 13), 2=151(LC 12)
Max Grav 4=498(LC 1), 2=622(LC 1)

FORCES. (lb) - Max. Comp./Max. Ten. - All forces 250 (lb) or less except when shown.

TOP CHORD 2-3=-704/256, 3-4=-701/267
BOT CHORD 2-5=-153/563, 4-5=-153/563
WEBS 3-5=-7/313

NOTES-

- Unbalanced roof live loads have been considered for this design.
- Wind: ASCE 7-16; Vult=130mph (3-second gust) Vasd=101mph; TC DL=4.2psf; BCDL=3.0psf; h=20ft; Cat. II; Exp B; Encl., GCpi=0.18; MWFRS (envelope) gable end zone and C-C Exterior(2E) -2-0-0 to 1-0-0, Interior(1) 1-0-0 to 6-10-0 to 9-10-0, Interior(1) 9-10-0 to 13-8-0 zone; C-C for members and forces & MWFRS for reactions shown; Lumber DOL=1.60 plate grip DOL=1.60
- Building Designer / Project engineer responsible for verifying applied roof live load shown covers rain loading requirements specific to the use of this truss component.
- This truss has been designed for a 10.0 psf bottom chord live load nonconcurrent with any other live loads.
- * This truss has been designed for a live load of 20.0psf on the bottom chord in all areas where a rectangle 3-6-0 tall by 2-0-0 wide will fit between the bottom chord and any other members.
- Provide mechanical connection (by others) of truss to bearing plate capable of withstanding 103 lb uplift at joint 4 and 151 lb uplift at joint 2.

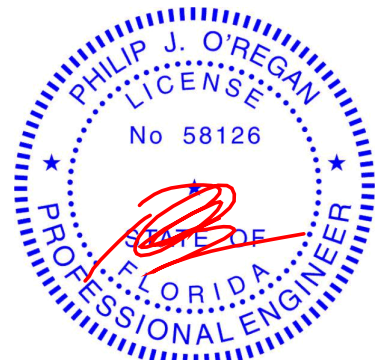

Philip J. O'Regan PE No.58126
MiTek USA, Inc. FL Cert 6634
6904 Parke East Blvd. Tampa FL 33610
Date:

February 11, 2022

WARNING - Verify design parameters and READ NOTES ON THIS AND INCLUDED MITEK REFERENCE PAGE MII-7473 rev. 5/19/2020 BEFORE USE.

Design valid for use only with MiTek® connectors. This design is based only upon parameters shown, and is for an individual building component, not a truss system. Before use, the building designer must verify the applicability of design parameters and properly incorporate this design into the overall building design. Bracing indicated is to prevent buckling of individual truss web and/or chord members only. Additional temporary and permanent bracing is always required for stability and to prevent collapse with possible personal injury and property damage. For general guidance regarding the fabrication, storage, delivery, erection and bracing of trusses and truss systems, see

ANSI/TPI1 Quality Criteria, DSB-89 and BCSI Building Component

Safety Information available from Truss Plate Institute, 2670 Crain Highway, Suite 203 Waldorf, MD 20601



6904 Parke East Blvd.
Tampa, FL 36610

Job	Truss	Truss Type	Qty	Ply	EVANS - FT WHITE SPEC	T26813934
3070916	T14G	Common Supported Gable	1	1		

Builders FirstSource (Lake City,FL), Lake City, FL - 32055,

8.430 s Aug 16 2021 MiTek Industries, Inc. Thu Feb 10 16:09:42 2022 Page 1

ID:KlqOOpJ4Z1Cn3VD1sa2GzOzmc6D-OK7QZMe9zpGXXZ3GpgMpTiiDRv4AYYvnW1PhR9zmUIN

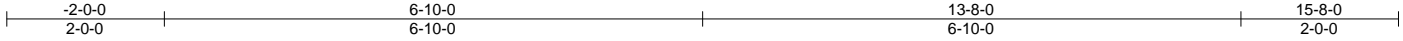

Scale = 1:29.2

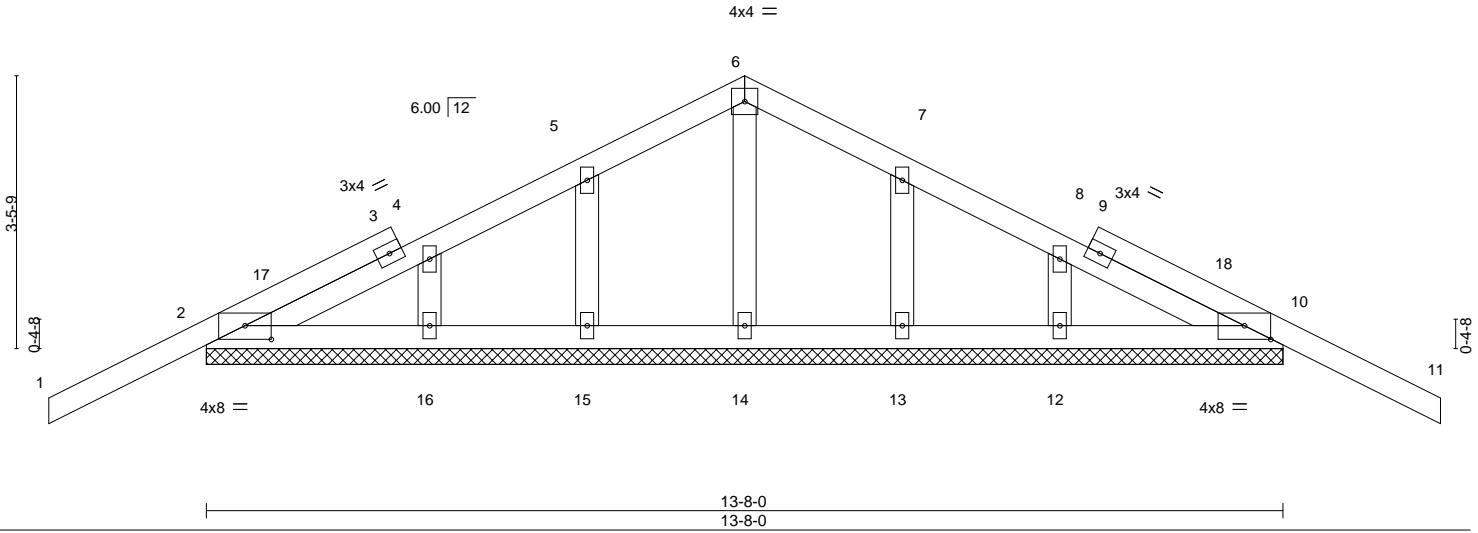

Plate Offsets (X,Y)-- [2:0-4-0-0-2-1], [10:0-4-0-0-2-1]

LOADING (psf)	SPACING-	CSL.	DEFL.	in (loc)	l/defl	L/d	PLATES	GRIP
TCLL 20.0	Plate Grip DOL 1.25	TC 0.23	Vert(LL) -0.02	11	n/r	120	MT20	244/190
TCDL 7.0	Lumber DOL 1.25	BC 0.05	Vert(CT) -0.03	11	n/r	120		
BCLL 0.0 *	Rep Stress Incr YES	WB 0.04	Horz(CT) 0.00	10	n/a	n/a		
BCDL 10.0	Code FBC2020/TPI2014	Matrix-S					Weight: 69 lb	FT = 20%

LUMBER-
 TOP CHORD 2x4 SP No.2
 BOT CHORD 2x4 SP No.2
 OTHERS 2x4 SP No.3

BRACING-
 TOP CHORD Structural wood sheathing directly applied or 6-0-0 oc purlins.
 BOT CHORD Rigid ceiling directly applied or 10-0-0 oc bracing.

REACTIONS. All bearings 13-8-0.
 (lb) - Max Horz 2=61(LC 13)
 Max Uplift All uplift 100 lb or less at joint(s) 2, 10, 15, 16, 13, 12
 Max Grav All reactions 250 lb or less at joint(s) 2, 10, 14, 15, 16, 13, 12

FORCES. (lb) - Max. Comp./Max. Ten. - All forces 250 (lb) or less except when shown.

- NOTES-**
- Unbalanced roof live loads have been considered for this design.
 - Wind: ASCE 7-16; Vult=130mph (3-second gust) Vasd=101mph; TCDL=4.2psf; BCDL=3.0psf; h=20ft; Cat. II; Exp B; Encl., GCpi=0.18; MWFRS (envelope) gable end zone and C-C Corner(3E) -2-0-0 to 6-10-0, Exterior(2N) 1-0-0 to 6-10-0, Corner(3R) 6-10-0 to 9-10-0, Exterior(2N) 9-10-0 to 15-8-0 zone;C-C for members and forces & MWFRS for reactions shown; Lumber DOL=1.60 plate grip DOL=1.60
 - Truss designed for wind loads in the plane of the truss only. For studs exposed to wind (normal to the face), see Standard Industry Gable End Details as applicable, or consult qualified building designer as per ANSI/TPI 1.
 - Building Designer / Project engineer responsible for verifying applied roof live load shown covers rain loading requirements specific to the use of this truss component.
 - All plates are 2x4 MT20 unless otherwise indicated.
 - Gable requires continuous bottom chord bearing.
 - Gable studs spaced at 2-0-0 oc.
 - This truss has been designed for a 10.0 psf bottom chord live load nonconcurrent with any other live loads.
 - * This truss has been designed for a live load of 20.0psf on the bottom chord in all areas where a rectangle 3-6-0 tall by 2-0-0 wide will fit between the bottom chord and any other members.
 - Provide mechanical connection (by others) of truss to bearing plate capable of withstanding 100 lb uplift at joint(s) 2, 10, 15, 16, 13, 12.
 - Beveled plate or shim required to provide full bearing surface with truss chord at joint(s) 2.

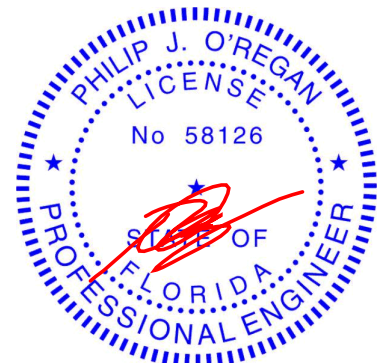

Philip J. O'Regan PE No.58126
 MiTek USA, Inc. FL Cert 6634
 6904 Parke East Blvd. Tampa FL 33610
 Date:

February 11,2022

WARNING - Verify design parameters and READ NOTES ON THIS AND INCLUDED MITEK REFERENCE PAGE MII-7473 rev. 5/19/2020 BEFORE USE.

Design valid for use only with MiTek® connectors. This design is based only upon parameters shown, and is for an individual building component, not a truss system. Before use, the building designer must verify the applicability of design parameters and properly incorporate this design into the overall building design. Bracing indicated is to prevent buckling of individual truss web and/or chord members only. Additional temporary and permanent bracing is always required for stability and to prevent collapse with possible personal injury and property damage. For general guidance regarding the fabrication, storage, delivery, erection and bracing of trusses and truss systems, see

ANSI/TPI1 Quality Criteria, DSB-89 and BCSI Building Component

Safety Information available from Truss Plate Institute, 2670 Crain Highway, Suite 203 Waldorf, MD 20601



6904 Parke East Blvd.
 Tampa, FL 36610

