

# Cool and Cobb Engineering Company

---

---

Date: 11/12/2024

Job: 24-1404

Job: Sarah Harlow

Location: 226 SW Dahlia Ln., Lake City, FL 32025

## PUSH PIER DESIGN ANALYSIS

The load requirements for the pilings designed to assist in supporting the identified areas of the subject residence were determined. The selected piling locations and the specific piling are identified on the Pier Identification and Location Plan attached. The calculated total loads on the piles in the specific location, including both dead and live loads are documented in the attached table which is designated as Attachment "A". Based on the total load requirements for each of these piles, the push pier driver is to be employed. The push pier driver should be employed with a calculated load of 10,500 lbs., which will provide pile capacity, including the 2 to 1 safety factor of 21,000 lbs. which is greater than the maximum calculated total load of 10,500 lbs. which occurs on the pile identified as no. 1. Based on this analysis, the use of the push pier driver for the ECP piles with a specific load of 21,000 lbs. and a minimum depth of 15' is approved and certified as meeting all the requirements of the Florida Building Code 2023 8<sup>th</sup> Edition, and good engineering practice. This is not to be the primary support structure, but a supplement support to assist in support of the weight of the structure, which will reduce the total pressure on the existing soils. After completion of installation, Cool and Cobb Engineering Company shall be supplied with a drilling log of the location and depths of each pile installed so they can evaluate the installation and prepare the "As Built" drawings.

### **General Notes:**

1. A log of each pile to be kept by Contractor noting depth for each pile.
2. Piles installed less than 48" apart are to be battered 10° away from each other.
3. All pile calculations are based on a maximum spacing of 8'-0".
4. This design is based on the loads of the structure placed on the shallow soils under the structure.
5. No deep soils geotechnical testing information was provided for this design.
6. This design does not address any possible sink hole activity as defined in Florida Statute § 627.706.

11/12/2024

Kenneth F Wheeler, P.E.

State of Florida

Professional Engineer No. 60417



Digitally signed  
by Kenneth F  
Wheeler

Date: 2024.11.12  
16:35:56 -05'00'

This item has been digitally signed and sealed by Kenneth F. Wheeler, P.E. on the date adjacent to the seal.

Printed copies of this document are not considered signed and sealed and the signature must be verified on any electronic copies.

203 W. Main St.  
Avon Park, FL 33825  
Office: (863) 657-2323  
Fax: (863) 657-2324

Concrete block structure  
 Age: 1977  
 Foundation: Concrete slab  
 Slab depth: 12"  
 Siding: Concrete Block  
 Roof: Shingle

FPI to install (6) Eccentric  
 Push Piers along the south  
 east corner of the home



**Legend**

- Foundation
- Exterior Pier

Digitally signed  
 by Kenneth F  
 Wheeler  
 Date: 2024.11.12  
 16:36:34 -05'00'

11/12/2024  
 Kenneth F. Wheeler, P.E.# 60417  
 Cool and Cobb Engineering Co.  
 203 W. Main St.,  
 Avon Park, FL 33825

This item has been digitally signed and sealed by Kenneth F. Wheeler, P.E. on the date adjacent to the seal.  
 Printed copies of this document are not considered signed and sealed and the signature must be verified on any electronic copies.

**Harlow - Foundation Repair**

**Foundation Professionals of Florida**  
 3309 SW State Road 247  
 Lake City, FL 32024  
 www.foundationprosfl.com  
 (386) 755-3002

**Project Address**  
 Sarah Harlow  
 226 S W Dahlia Ln  
 Lake City, FL 32025  
 (386) 365-3602 | saray5560@msn.com

**Created By**  
 Conner Rawlins  
 (904) 515-8680  
 crawlins@foundationprosfl.com  
 Created 10/29/2024



# Cool and Cobb Engineering Company

Date: 11/12/2024  
Job: Sarah Harlow  
Location: 226 SW Dahlia Ln., Lake City, FL 32025

Project # 24-1404

## Attachment "A"

Total Load on Support (Live Load + Dead Load)

SUPPORT NO.	TOTAL CALCULATE LOAD	
1	10,500	lbs
2	9,000	lbs
3	7,500	lbs
4	6,000	lbs
5	7,200	lbs
6	8,400	lbs

Maximum Total Load on Pile: 10,500 lbs



Digitally signed  
by Kenneth F  
Wheeler  
Date: 2024.11.12  
16:36:49 -05'00'

11/12/2024  
Kenneth F Wheeler, P.E.  
PE# 60417

This item has been digitally signed and sealed by Kenneth F. Wheeler, P.E. on the date adjacent to the seal.

Printed copies of this document are not considered signed and sealed and the signature must be verified on any electronic copies.

Cool and Cobb Engineering Co.  
203 W. Main St.  
Avon Park, FL 33825

## ECP Steel Pier™ - PPB-250 Utility Bracket Pier System

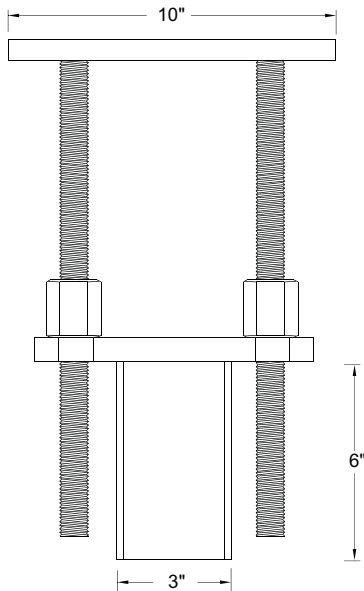

PPB-250  
Utility Bracket Details

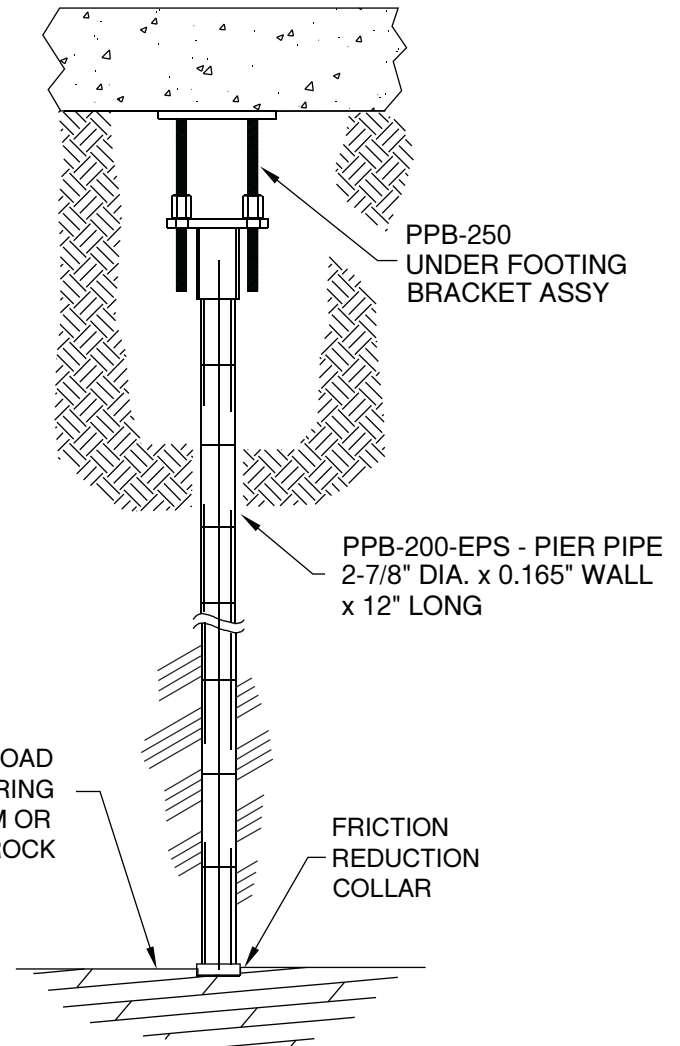

- **Ultimate Capacity – 54,000 lb**
- **Fully Adjustable Unlimited Lift Capability**
- **Installs From Outside or Inside Structure**
- **Friction Reduction Collar On Lead Pier Section**
- **Installs With Portable Equipment**
- **Installed With Little or No Vibration**
- **Installs To Rock or Verified Load Bearing Stratum**
- **100% of Piers Field Load Tested During Installation**

**EARTH  
CONTACT  
PRODUCTS**

**1-866-327-0007**

15612 S Keeler Terr.  
Olathe, Ks 66062  
Phone: 913-393-0007  
Fax: 913-393-0008  
info@getecp.com  
www.getecp.com



11/12/2024

Kenneth F. Wheeler, P.E.# 60417  
Cool and Cobb Engineering Co.  
203 W. Main St., Avon Park, FL 33825

## The ECP Concentric Pier

The Patented ECP PPB-250 concentric pier is the latest in steel resistance piercing. The unique design and engineering allows you to use ECP push pier technology directly beneath the load or footing. The steel pier design penetrates the soil deeply beyond the active expansive clay soils to a true end bearing configuration. ECP, the leaders in steel pier technologies, has created the strongest and deepest driving concentric pier system on the market today!

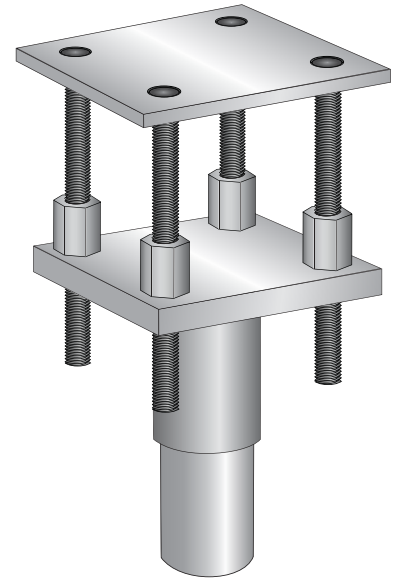

## *Another Choice for Foundation Repair Underpinning!*

No longer do you have to settle for weak, shallow driving under footing piers. The PPB-250 pier system drives deeper, lifts larger loads and is more stable than any other concentric pier on the market. The engineers at Earth Contact Products developed this pier to be placed directly under loads for crawl space applications, limited access areas and slab on grade homes.

The PPB-250 steel pier was designed to be the strongest foundation pier in the industry by combining galvanized steel pier material with a manifold lifting system. It is installed centrally beneath the footing rather than outside of the footing, thus transferring the structural load directly on top of the pier bracket. Our concentric pier system will achieve the greatest depth while installed in a position to provide the greatest support.

### **Designed to be the strongest foundation structural support in the industry**

- Made of galvanized steel pier material
- Sturdy enough for commercial foundations
- Uses hydraulic manifold lifting system
- Installs with industry leading 10,000 psi system
- Designed by engineers for homeowners

**Creates a deep foundation that exceeds your home's original structural strength!**

**EARTH  
CONTACT  
PRODUCTS**

**1-866-327-0007**

15612 S Keeler Terr.

Olathe, Ks 66062

Phone: 913-393-0007

Fax: 913-393-0008

info@getecp.com

www.getecp.com

11/12/2024

Kenneth F. Wheeler, P.E.# 60417

Cool and Cobb Engineering Co.

203 W. Main St., Avon Park, FL 33825