

GENERAL NOTES

- DESIGN IS FOR MAXIMUM 30'-0" WIDE X 20'-0" EAVE HEIGHT FULLY ENCLOSED STRUCTURES.
- APPLICABLE CODES, REGULATIONS, & STANDARDS:
 - 2023 FLORIDA BUILDING CODE (8TH EDITION)
 - 2024 INTERNATIONAL BUILDING CODE
 - ASCE 7-22: MINIMUM DESIGN LOADS ON BUILDINGS AND OTHER STRUCTURES
 - AISC STEEL CONSTRUCTION MANUAL (15TH EDITION)
 - ACI 318-19: BUILDING CODE REQUIREMENTS FOR STRUCTURAL CONCRETE
 - TMS 402-16: BUILDING CODE REQUIREMENTS FOR MASONRY STRUCTURES
 - AWS D1.1: STRUCTURAL WELDING
- RISK CATEGORY: I
- EXPOSURE CATEGORY: C
- LOW ULTIMATE WIND SPEED 105 TO 150 MPH (NOMINAL WIND SPEED 81 TO 116 MPH); MAXIMUM RAFTER/POST AND END POST SPACING = 5.0 FEET.
HIGH ULTIMATE WIND SPEED 151 TO 180 MPH (NOMINAL WIND SPEED 117 TO 139 MPH); MAXIMUM RAFTER/POST AND END POST SPACING = 4.0 FEET.
- DEAD LOAD = 5 PSF
- ROOF LIVE LOAD = 12 PSF
- SPECIFICATIONS APPLICABLE TO 29/26 GAUGE METAL PANELS FASTENED DIRECTLY TO 2 1/2" x 2 1/2" - 14 GAUGE TUBE STEEL (TS) FRAMING MEMBERS FOR VERTICAL PANELS, 29/26 GAUGE METAL PANELS SHALL BE FASTENED TO 18 GAUGE HAT CHANNELS (UNLESS OTHERWISE NOTED).
- OPTIONAL BASE RAIL ANCHORAGE MAY BE USED FOR LOW AND MUST BE USED FOR HIGH WIND SPEEDS.
- FASTENERS CONSIST OF #12-14 x 3/4" SELF DRILLING FASTENER (SDF), USE CONTROL SEAL WASHER WITH EXTERIOR FASTENERS SPECIFICATIONS APPLICABLE ONLY FOR MEAN ROOF HEIGHT OF 20 FEET OR LESS, AND ROOF SLOPES OF 14° (3:12 PITCH) OR LESS SPACING REQUIREMENTS FOR OTHER ROOF HEIGHTS AND/OR SLOPES MAY VARY.
- AVERAGE FASTENER SPACING ON-CENTERS ALONG RAFTERS OR PURLINS, AND POSTS, INTERIOR = 9" OR END = 6", (MAX.). THIS CONNECTION PATTERN SHALL BE SUPERCEDED BY THE PANEL MANUFACTURER'S INSTALLATION INSTRUCTIONS.
- WIND FORCES GOVERN OVER SEISMIC FORCES. SEISMIC PARAMETERS ANALYZED ARE:
SOIL SITE CLASS = D
R = 3.25 Ie = 1.0
Sds = 0.087 g V = CsW
Sdi = 0.084 g
- GROUND ANCHORS SHALL BE INSTALLED THROUGH BASE RAIL WITHIN 6" OF EACH RAFTER COLUMN ALONG SIDES.
- GROUND ANCHOR (SOIL NAILS) CONSIST OF #5 REBAR W/ WELDED NUT X 30" LONG IN SUITABLE SOIL CONDITIONS MAY BE USED FOR LOW (≤ 108 MPH NOMINAL) WIND SPEEDS ONLY. OPTIONAL ANCHORAGE MAY BE USED IN SUITABLE SOILS AND MUST BE USE IN UNSUITABLE SOILS AS NOTED.
- MIN. LAP REQUIREMENT FOR REBAR IN FOOTER IS 25".
- SOIL TO BE COMPACTED TO 95% OF ITS MAXIMUM DRY DENSITY, AT OPTIMUM MOISTURE CONTENT, IN ACCORDANCE WITH ASTM D1557-93
- PRIOR TO PLACING CONCRETE, TREAT THE ENTIRE SUBSURFACE AREA FOR TERMITES IN COMPLIANCE WITH THE FBC.
- A LANDING OF MIN. 36" WIDTH IN THE DIRECTION OF TRAVEL SHALL BE PROVIDED AT THE EXTERIOR DOORS. SLOPE OF LANDING NOT TO EXCEED 1/4"-1'. LANDING LEVEL NOT TO BE LOWER THAN 1-1/2" (FOR EGRESS DOORS) & 7-3/4" (FOR OTHER EXTERIOR DOORS) BELOW THE TOP OF THRESHOLD.
- CONTRACTOR TO PROVIDE APPROVED PRODUCTS THAT MEET OR EXCEED WIND DESIGN PRESSURES.
- CONSTRUCTION IN SPECIAL FLOOD HAZARD AREAS:
CONTRACTOR TO VERIFY THAT THE FINISHED FLOOR ELEVATION FOR THE PROPOSED STRUCTURE IS AT OR ABOVE THE GREATER OF THE FOLLOWING ELEVATIONS:
I) BFE (BASE FLOOD ELEVATION) + 2'-0"
II) DFE (DESIGN FLOOD ELEVATION)
III) THE MINIMUM ELEVATION MANDATED BY THE BUILDING CODES ADOPTED BY THE AUTHORITY HAVING JURISDICTION.

**ENCLOSED METAL BUILDING DESIGN
MAXIMUM 30'-0" WIDE X 20'-0" EAVE HEIGHT
BOX/BOW EAVE FRAME**

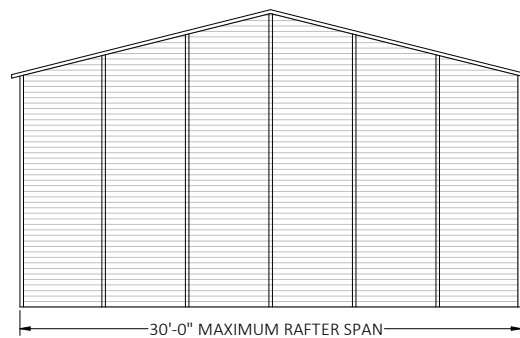

TYPICAL END ELEVATION - HORIZONTAL ROOF

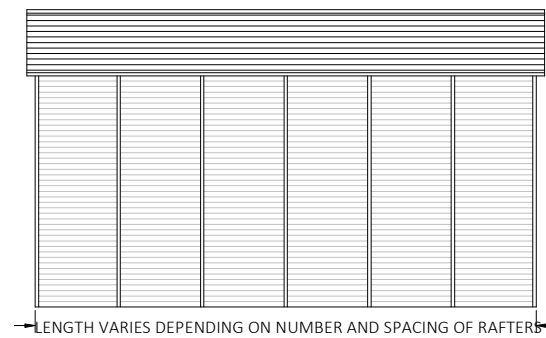

TYPICAL SIDE ELEVATION - HORIZONTAL ROOF

BOX EAVE FRAME RAFTER ENCLOSED BUILDING

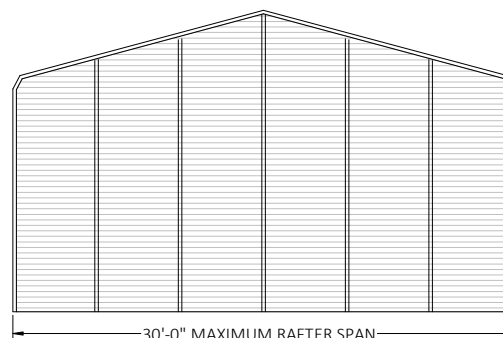

TYPICAL END ELEVATION

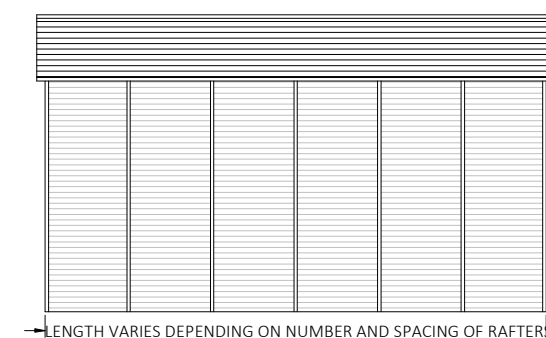

TYPICAL SIDE ELEVATION

BOW FRAME RAFTER ENCLOSEDBUILDING

This item has been digitally signed and sealed by Richard E. Walker, P.E. on the date adjacent to the seal. Printed copies of this document are not considered signed and sealed and the signature must be verified on any electronic copies.

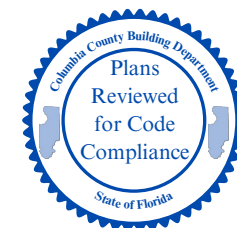

FLORIDA ENGINEERING LLC
4161 TAMiami TRAIL, UNIT 101
PORT CHARLOTTE, FLORIDA 33952

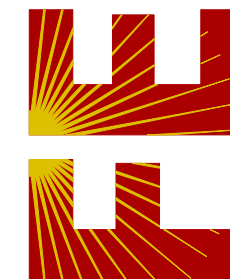

(941) 391-5980

FLEng.com
Orders@FLEng.com

CA CERT. #30782

PROJECT NO. 2504211-30-E

FLORIDA ENGINEERING LLC PROJECT NO. 2504211-30-E SIGNED AND SEALED DATED 03/27/2025 REVISES AND SUPERSEDES FLORIDA ENGINEERING LLC PROJECT NO. 2322771-30-E SIGNED AND SEALED DATED 03/04/2024.

DIGITAL CERTIFICATION NOTES:
1. THIS DOCUMENT HAS BEEN DIGITALLY SIGNED AND SHALL REMAIN IN DIGITAL FORMAT, SHALL BE VERIFIED BY ELECTRONIC MEANS & PRINTED COPIES OF THIS DOCUMENT ARE NOT CONSIDERED SIGNED AND SEALED.
2. THIS DOCUMENT HAS BEEN CREATED BY FLORIDA ENGINEERING LLC FOR TUBULAR BUILDING SYSTEMS ONLY. IT SHALL NOT BE REPRODUCED IN WHOLE OR PART WITHOUT THE WRITTEN CONSENT OF FLORIDA ENGINEERING LLC AND TUBULAR BUILDING SYSTEMS.
3. ALTERATIONS, ADDITIONS OR OTHER MARKINGS TO THIS DOCUMENT ARE NOT PERMITTED AND INVALIDATE FLORIDA ENGINEERING LLC'S CERTIFICATION.
4. THESE PLANS ARE GENERIC AND DO NOT PROVIDE INFORMATION FOR A SITE-SPECIFIC PROJECT WHERE THE SITE CONDITIONS DEVIATE FROM WHAT HAS BEEN CALLED OUT ON THESE PLANS.
5. CONTRACTOR MUST NOT DEVIATE FROM THE CONDITIONS DETAILED ON THESE PLANS.
6. CONSTRUCTION SAFETY AT THE SITE IS THE CONTRACTOR'S RESPONSIBILITY.

DRAWING INDEX

PAGE NO.	DESCRIPTION
1	NOTES AND SPECIFICATIONS
2	BOX EAVE FRAME RAFTER ENCLOSED BUILDING
3	BOW EAVE FRAME RAFTER ENCLOSED BUILDING
4	BASE RAIL AND FOUNDATION ANCHORAGE
5	BOX/BOW EAVE VERTICAL ROOF/SIDING OPTION
6	BOX/BOW EAVE RAFTER LEAN-TO OPTIONS
7	BOX EAVE RAFTER END WALL, SIDE WALL AND OPENING FRAMING
8	VENT AND CMU STEM WALL DETAIL
9	OPTIONAL CONCRETE STRIP FOOTING

CONTRACTOR:

TUBULAR BUILDING SYSTEMS
631 SE INDUSTRIAL CIRCLE,
LAKE CITY, FL 32025

PROJECT DESCRIPTION:

30' WIDE X 20' HIGH
ENCLOSED STRUCTURE

DESIGN DATE: 03/27/2025

REVISION 1: DATE

REVISION 2: DATE

SCALE: NTS

PAGE :

1

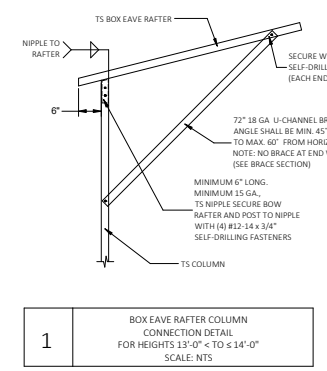
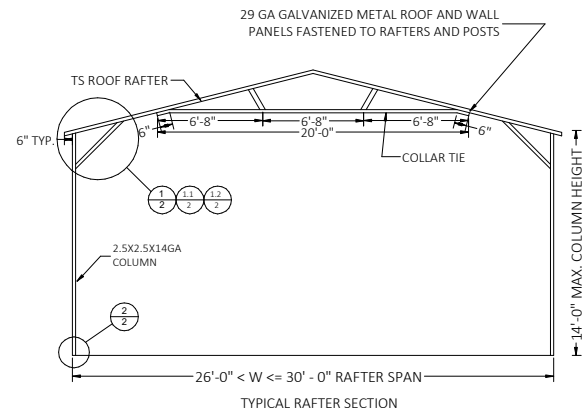
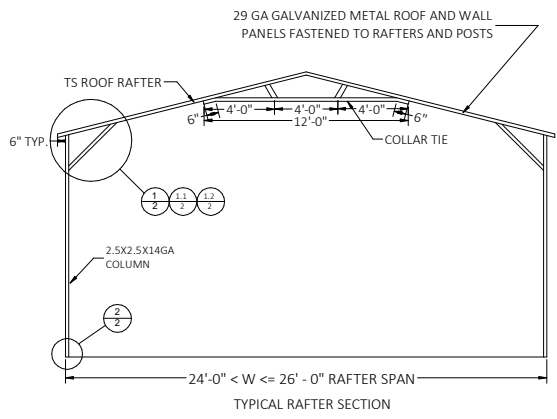
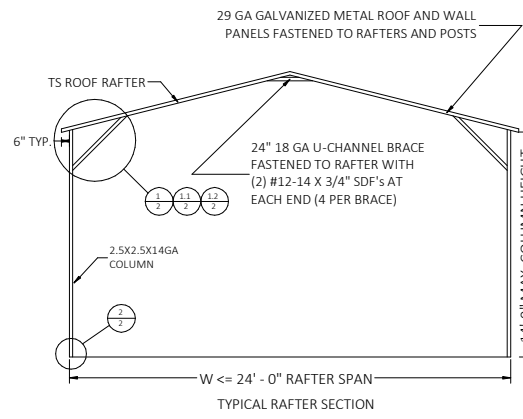

This item has been digitally signed and sealed by Richard E. Walker, P.E. on the date adjacent to the seal. Printed copies of this document are not considered signed and sealed and the signature must be verified on any electronic copies.

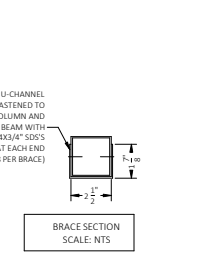
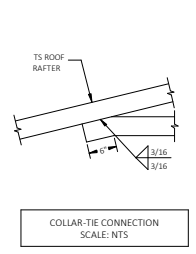
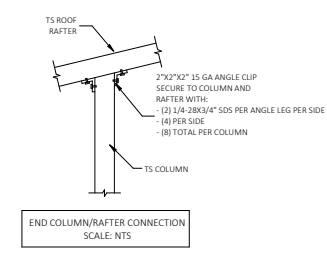
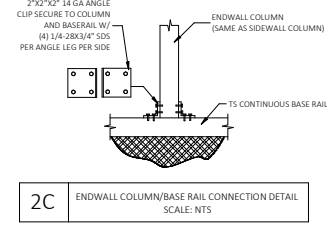
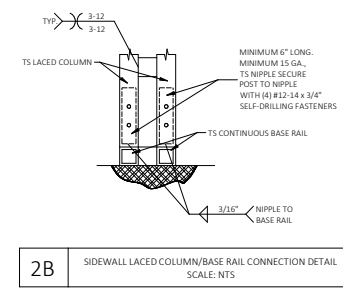
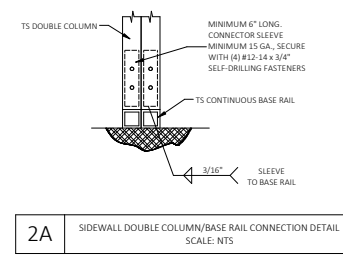
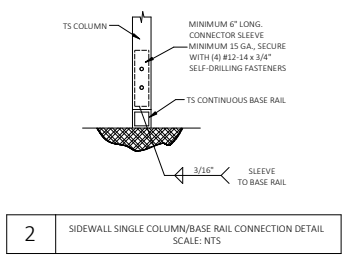
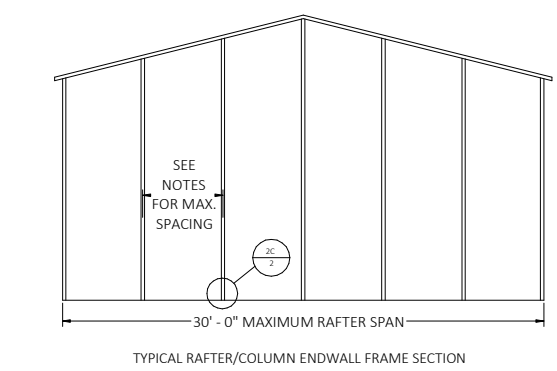
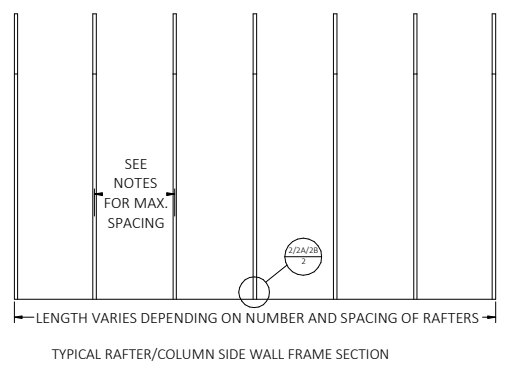
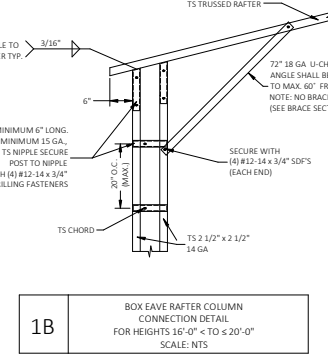
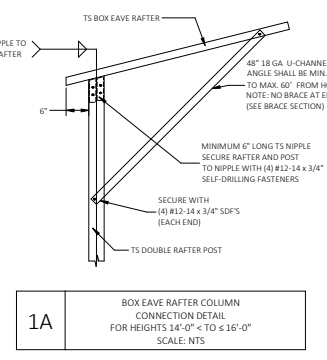
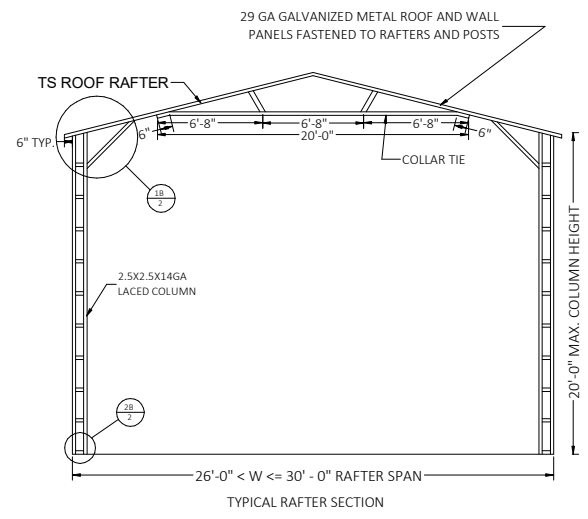
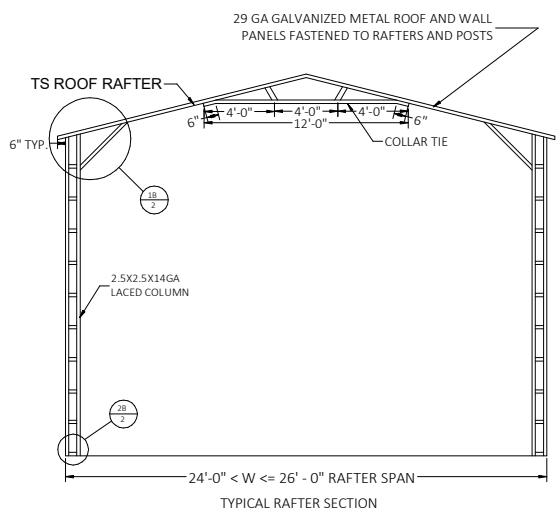
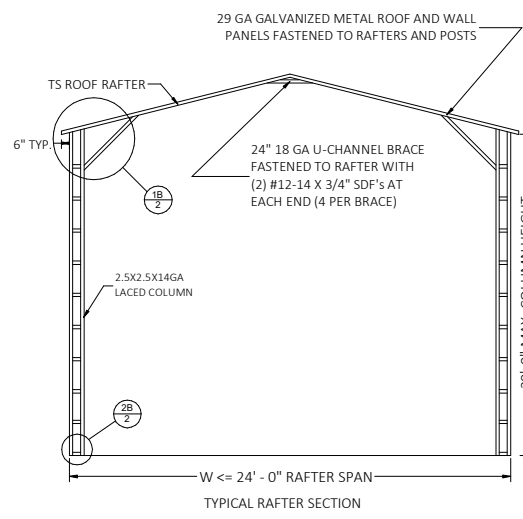
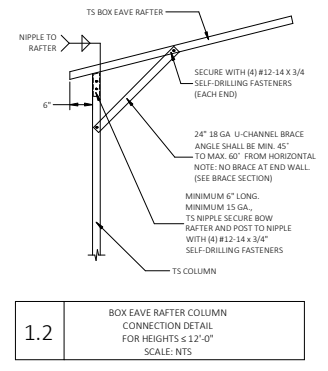
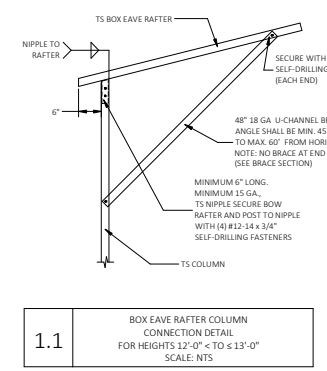
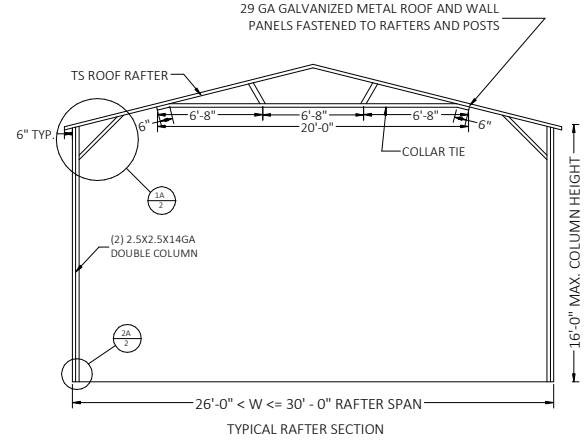
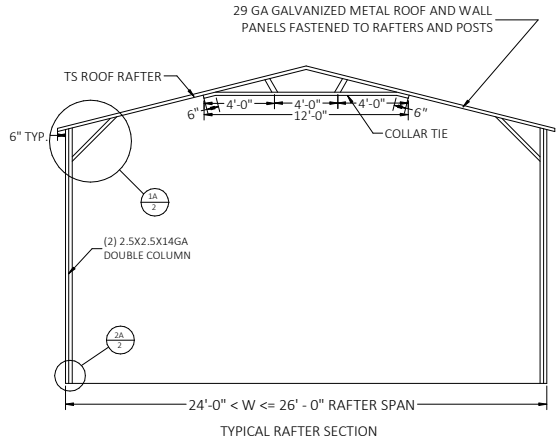
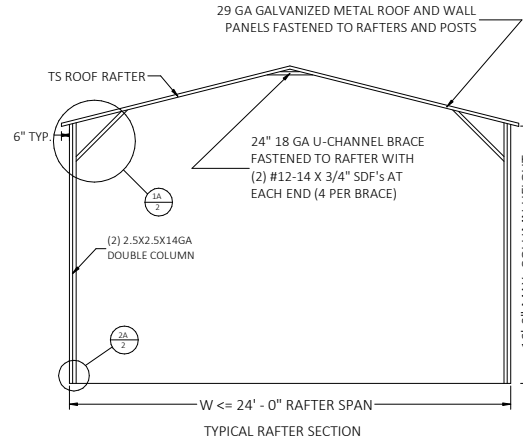

FLORIDA ENGINEERING LLC
 4161 TAMiami TRAIL, UNIT 101
 PORT CHARLOTTE, FLORIDA 33952
 (941) 391-5980
 FLEng.com
 Orders@FLEng.com

PROJECT NO. 2504211-30-E

CONTRACTOR:
TUBULAR BUILDING SYSTEMS
 631 SE INDUSTRIAL CIRCLE,
 LAKE CITY, FL 32025

PROJECT DESCRIPTION:
 30' WIDE X 20' HIGH
 ENCLOSED STRUCTURE

DESIGN DATE: 03/27/2025

REVISION 1: DATE
 REVISION 2: DATE
 SCALE: NTS

PAGE: **2**

CA CERT. #30782

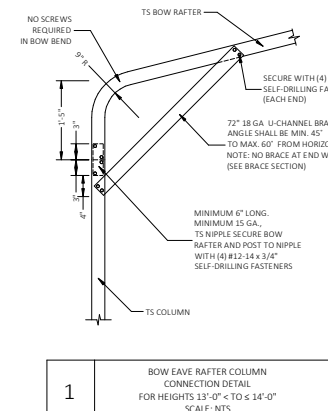
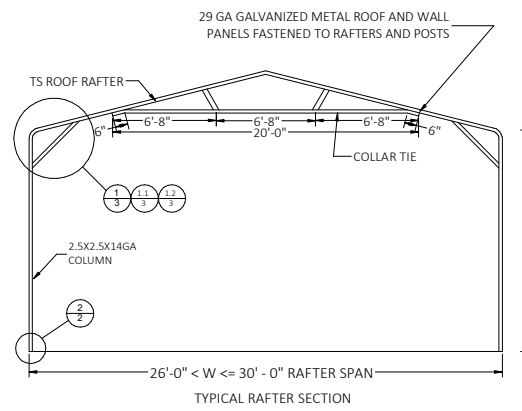
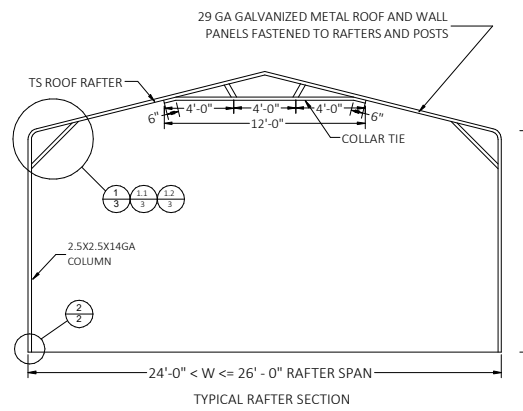
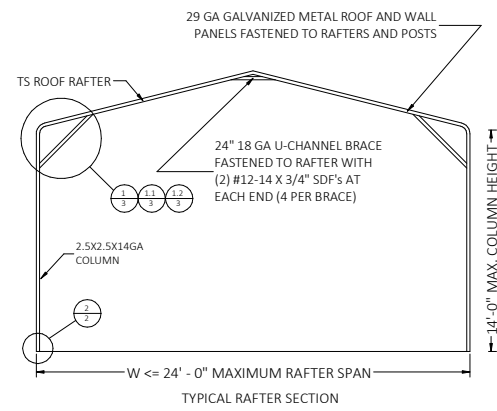

This item has been digitally signed and sealed by Richard E. Walker, P.E. on the date adjacent to the seal. Printed copies of this document are not considered signed and sealed and the signature must be verified on any electronic copies.

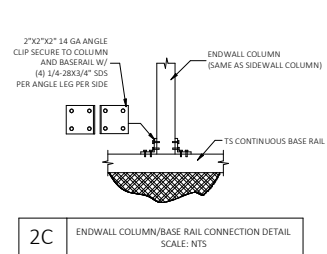
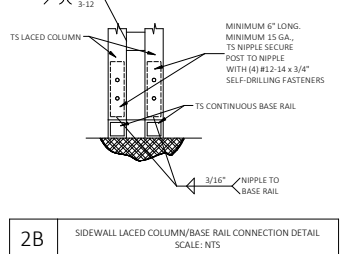
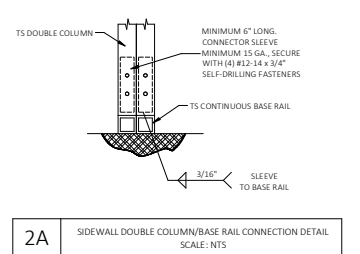
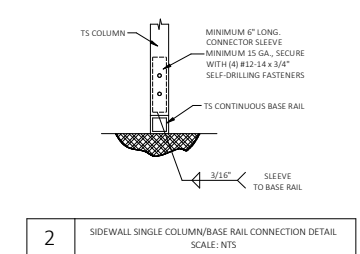
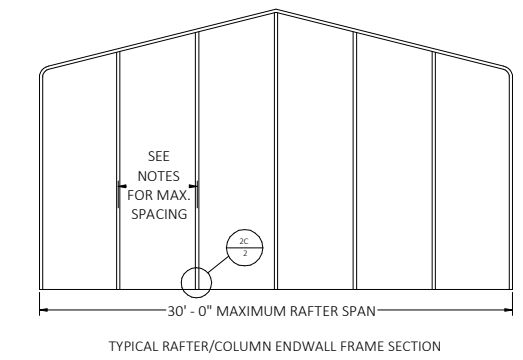
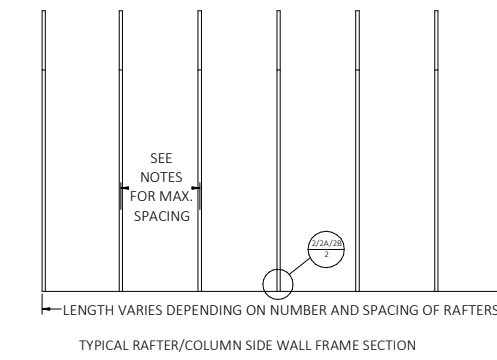
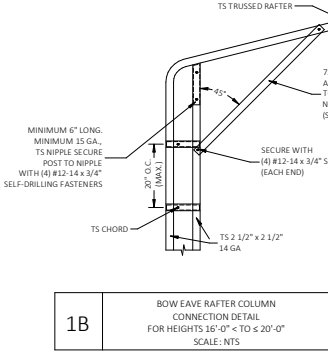
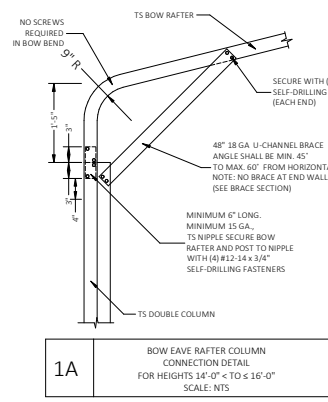
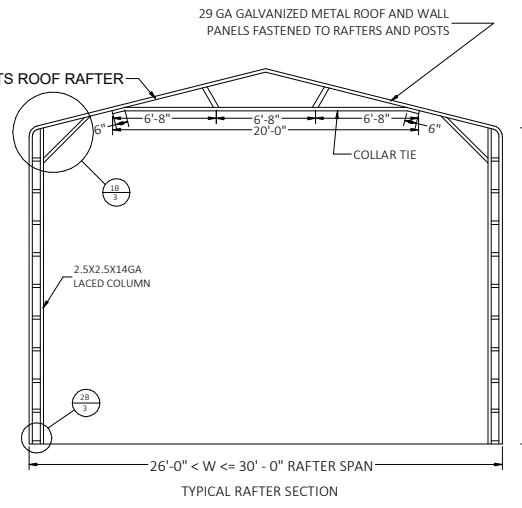
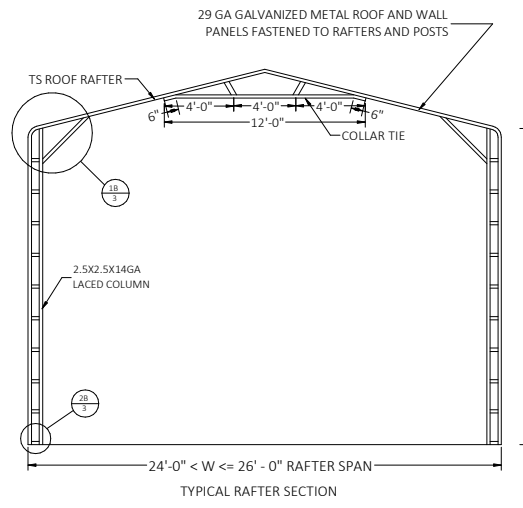
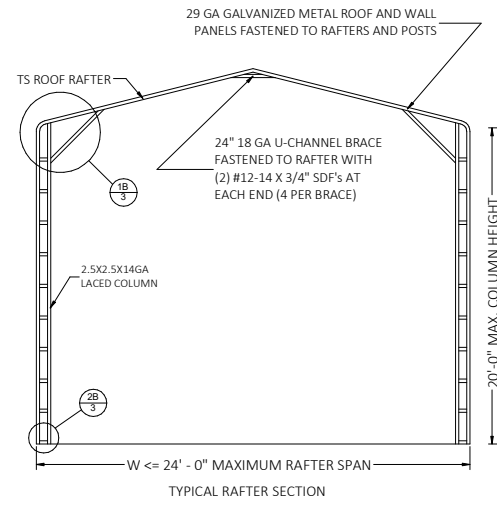
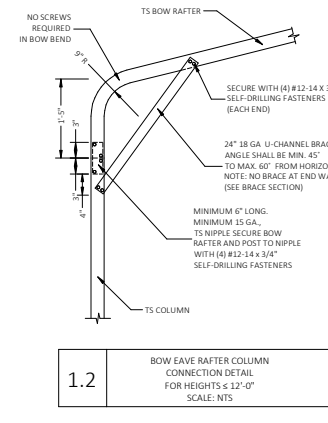
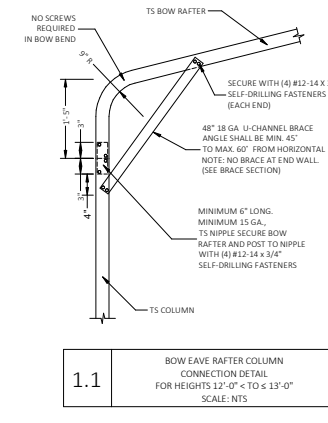
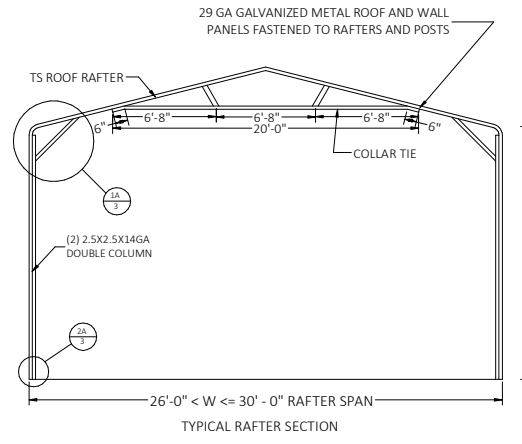
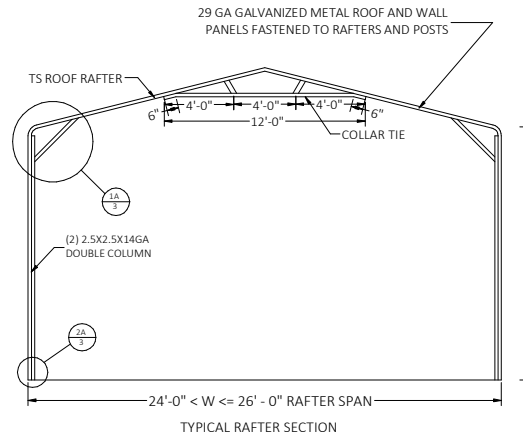
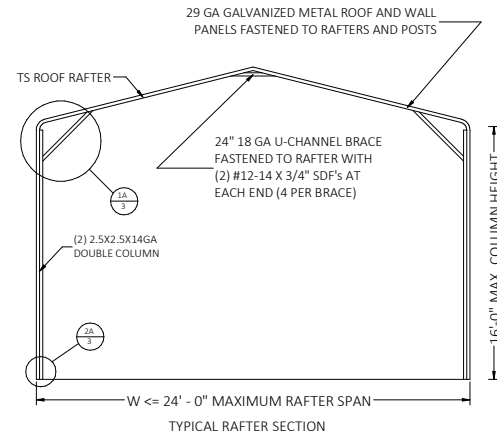

FLORIDA ENGINEERING LLC
 4161 TAMiami TRAIL, UNIT 101
 PORT CHARLOTTE, FLORIDA 33952
 (941) 391-5980
 FLEng.com
 Orders@FLEng.com
 CA CERT. #30782

PROJECT NO. 2504211-30-E

CONTRACTOR:
TUBULAR BUILDING SYSTEMS
 631 SE INDUSTRIAL CIRCLE,
 LAKE CITY, FL 32025

PROJECT DESCRIPTION:
 30' WIDE X 20' HIGH
 ENCLOSED STRUCTURE

DESIGN DATE: 03/27/2025

REVISION 1: DATE
 REVISION 2: DATE
 SCALE: NTS

PAGE :
3

BASE RAIL ANCHORAGE OPTIONS FOR LOW AND HIGH WIND SPEED

GENERAL NOTES

CONCRETE:

1. CONCRETE SHALL HAVE A MINIMUM SPECIFIED COMPRESSIVE STRENGTH OF 3000 PSI AT 28 DAYS.
2. PRIOR TO PLACING CONCRETE, TREAT THE ENTIRE SUBSURFACE AREA FOR TERMITES IN COMPLIANCE WITH THE FBC.
3. MINIMUM SOIL BEARING CAPACITY OF COMPACTED GRADE= 2000 PSF

COVERAGE OF THE REINFORCED STEEL:

FOR FOUNDATIONS, MINIMUM CONCRETE COVER OVER REINFORCING BARS SHALL BE PER ACI-318: 3 INCHES WHERE THE CONCRETE IS POURED AGAINST AND TEMPORARY IN CONTACT WITH THE EARTH OR UNPROTECTED FROM THE EARTH OR WEATHER, OTHERWISE 1-1/2 INCHES.

REINFORCING STEEL:

THE TURNDOWN REINFORCING STEEL SHALL BE ASTM A615 GRADE 60. THE SLAB REINFORCEMENT SHALL BE WELDED WIRE FABRIC MEETING ASTM A185 OR FIBERGLASS FIBER REINFORCEMENT.

REINFORCEMENT MAY BE BENT IN THE FIELD OR SHOP AS LONG AS:

1. IT IS BENT COLD;
2. REINFORCEMENT PARTIALLY EMBEDDED IN CONCRETE SHALL NOT BE FIELD BENT;
3. THE DIAMETER OF THE BEND, MEASURED ON THE INSIDE OF THE BAR, IS NOT LESS THAN SIX-BAR DIAMETERS.
4. MINIMUM REQUIRED LAP LENGTH SHALL NOT BE LESS THAN 57-BAR DIAMETERS.

HELIX ANCHOR NOTES

1. FOR VERY DENSE AND/OR CEMENTED SANDS, COARSE GRAVEL AND COBBLES, CALICHE, PRELOADED SILTS AND CLAYS USE MINIMUM (2) 4" HELICES WITH MINIMUM 30 INCH EMBEDMENT.
2. FOR CORAL USE MINIMUM (2) 4" HELICES WITH MINIMUM 30 INCH EMBEDMENT.
3. FOR MEDIUM DENSE COARSE SANDS, SANDY GRAVELS, VERY STIFF SILTS AND CLAYS USE MINIMUM (2) 4" HELICES WITH MINIMUM 30 INCH EMBEDMENT.
4. FOR LOOSE TO MEDIUM DENSE COARSE SANDS, FIRM TO STIFF CLAYS AND SILTS ALLUVIAL FILL USE MINIMUM (2) 6" HELICES WITH MINIMUM 50 INCH EMBEDMENT.
5. FOR VERY LOSE TO MEDIUM DENSE SANDS, FIRM TO STIFFER CLAYS AND SILTS, ALLUVIAL FILL USE MINIMUM (2) 8" HELICES WITH MINIMUM 60 INCH EMBEDMENT.

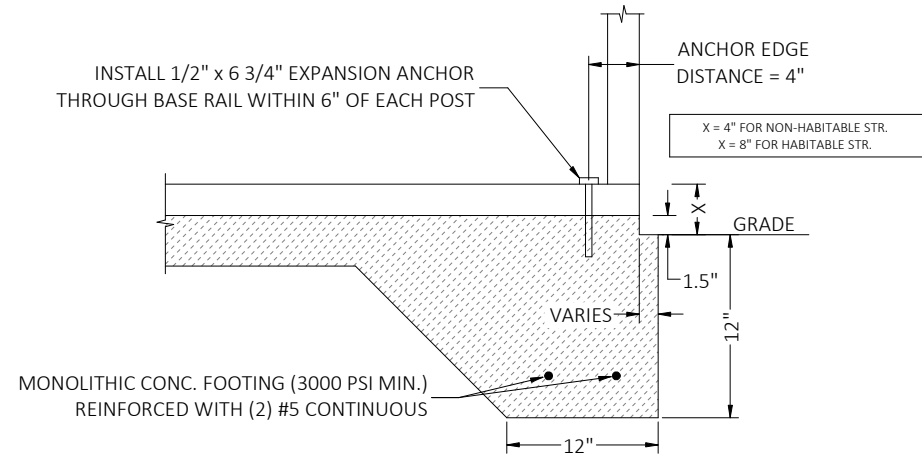

3A1 CONCRETE MONOLITHIC SLAB BASE RAIL ANCHORAGE
SCALE: NTS

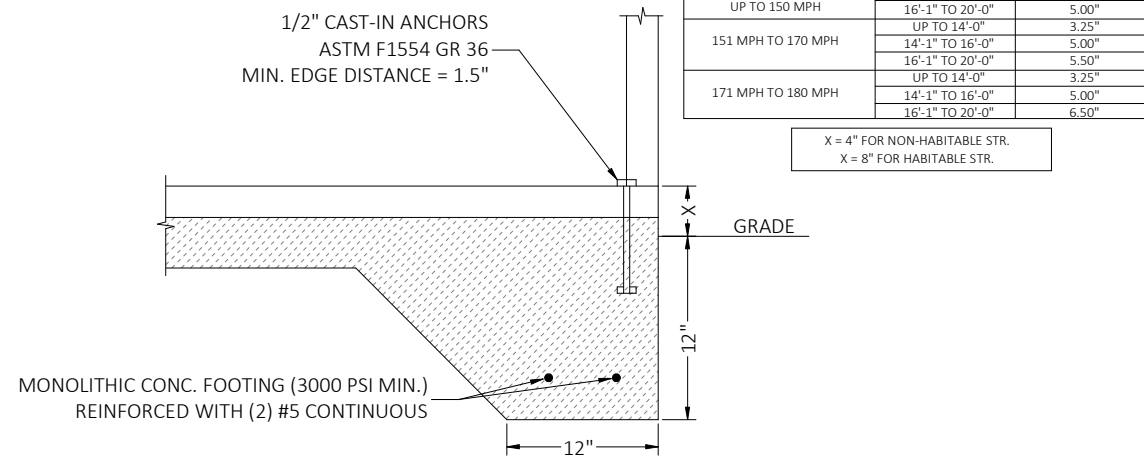

3A2 CONCRETE MONOLITHIC SLAB BASE RAIL ANCHORAGE
SCALE: NTS

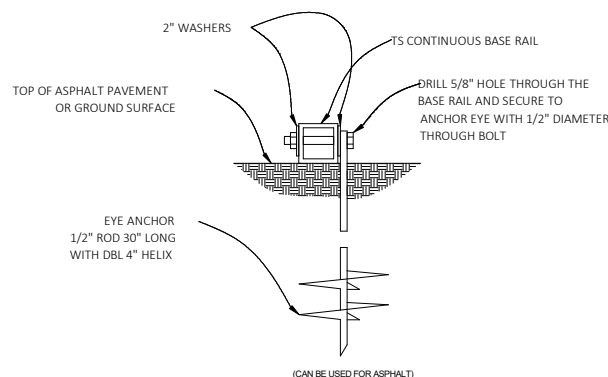

3B GROUND BASE HELIX ANCHORAGE
SCALE: NTS

WIND SPEED	WALL HEIGHT	MIN. ANCHOR EMBEDMENT
UP TO 150 MPH	UP TO 16'-0"	3.25"
	16'-1" TO 20'-0"	5.00"
151 MPH TO 170 MPH	UP TO 14'-0"	3.25"
	14'-1" TO 16'-0"	5.00"
171 MPH TO 180 MPH	16'-1" TO 20'-0"	5.50"
	UP TO 14'-0"	3.25"
	14'-1" TO 16'-0"	5.00"
	16'-1" TO 20'-0"	6.50"

X = 4" FOR NON-HABITABLE STR.
X = 8" FOR HABITABLE STR.

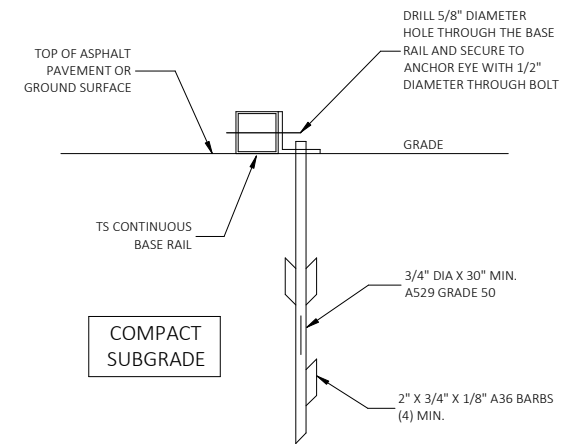

3C ASPHALT BASE ANCHORAGE (HP 9 BARBED DRIVE ANCHOR)
SCALE: NTS

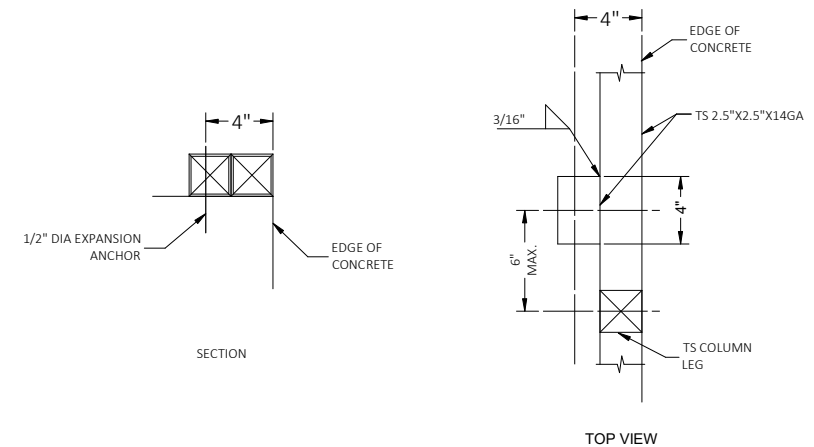

3D TYPICAL ANCHOR DETAIL WHEN BASE RAIL IS NEAR EDGE OF CONCRETE
SCALE: NTS

This item has been digitally signed and sealed by Richard E. Walker, P.E. on the date adjacent to the seal. Printed copies of this document are not considered signed and sealed and the signature must be verified on any electronic copies.

FLORIDA ENGINEERING LLC
4161 TAMiami TRAIL, UNIT 101
PORT CHARLOTTE, FLORIDA 33952
(941) 391-5980
FLEng.com
Orders@FLEng.com

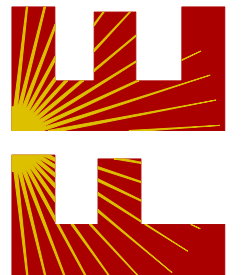

CONTRACTOR:
TUBULAR BUILDING SYSTEMS
631 SE INDUSTRIAL CIRCLE,
LAKE CITY, FL 32025

PROJECT DESCRIPTION:

30' WIDE X 20' HIGH
ENCLOSED STRUCTURE

DESIGN DATE:	03/27/2025
REVISION 1:	DATE
REVISION 2:	DATE
SCALE:	NTS

CA CERT. #30782

PROJECT NO. 2504211-30-E

BOX EAVE RAFTER HORIZONTAL SIDE PANEL OPTION

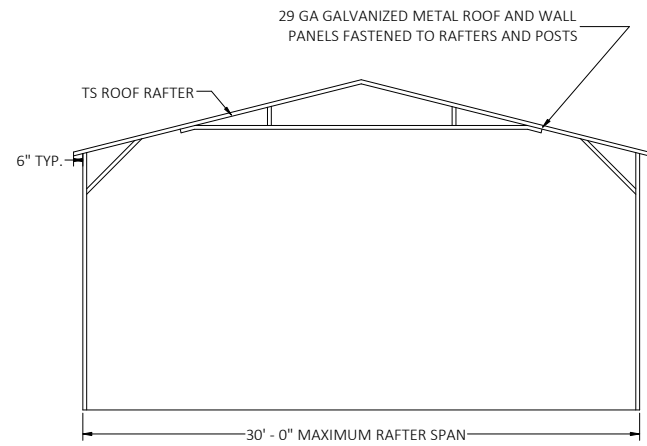

TYPICAL RAFTER/POST FRAME SECTION EXTRA SIDE PANELS

BOW RAFTER GABLE END OPTION

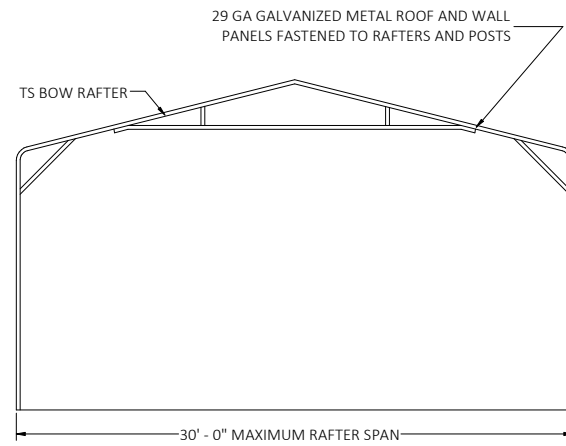

TYPICAL RAFTER/POST FRAME SECTION EXTRA SIDE PANELS

BOX EAVE RAFTER VERTICAL ROOF OPTION

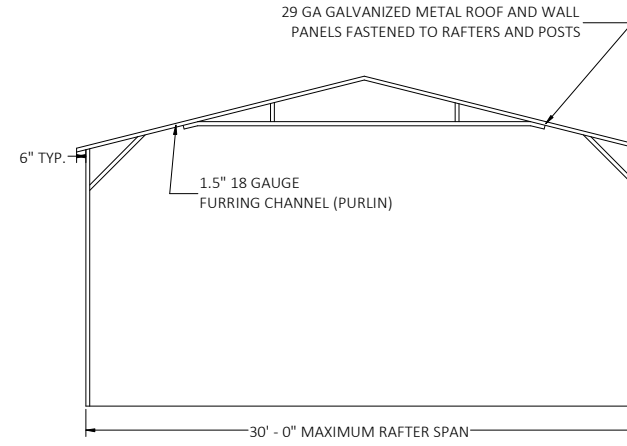

TYPICAL SECTION VERTICAL ROOF/SIDING OPTION

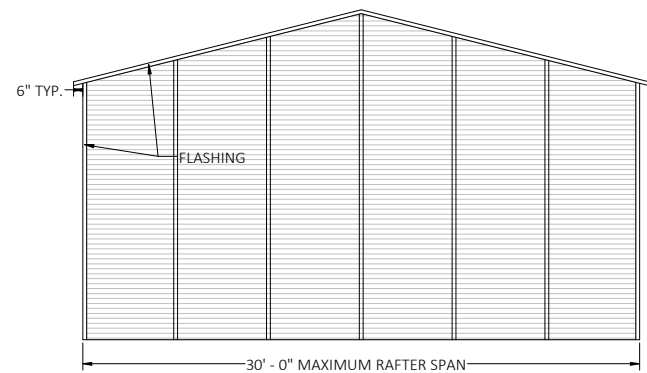

TYPICAL END ELEVATION EXTRA SIDE PANELS

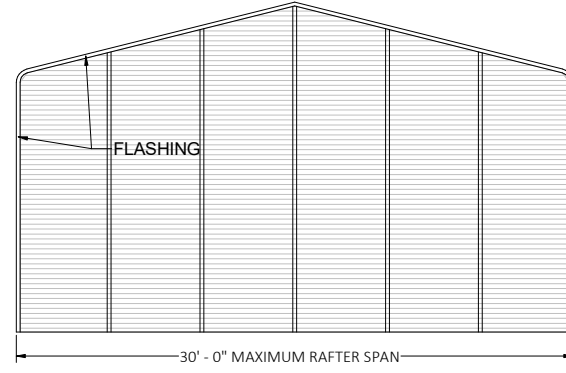

TYPICAL END ELEVATION EXTRA SIDE PANELS

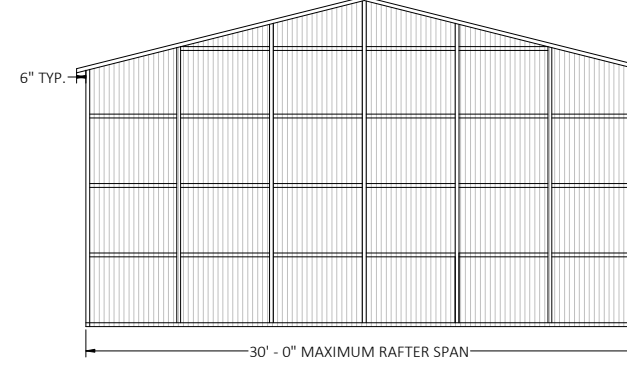

TYPICAL END ELEVATION VERTICAL ROOF/SIDING OPTION

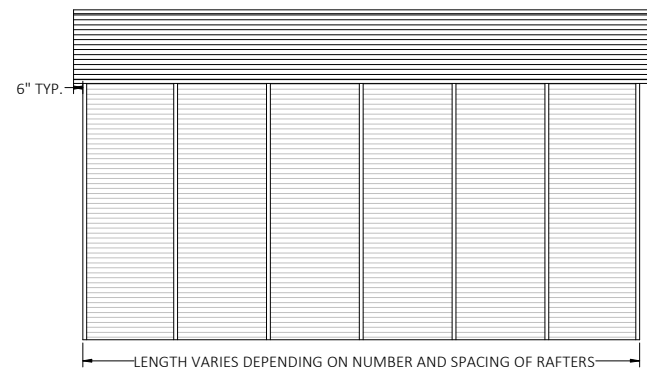

TYPICAL SIDE ELEVATION - EXTRA SIDE PANELS

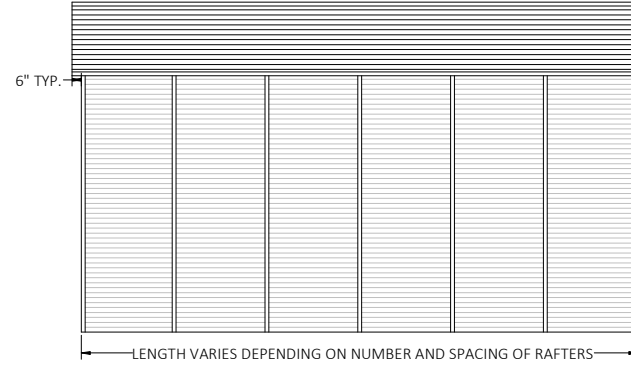

TYPICAL SIDE ELEVATION - EXTRA SIDE PANELS

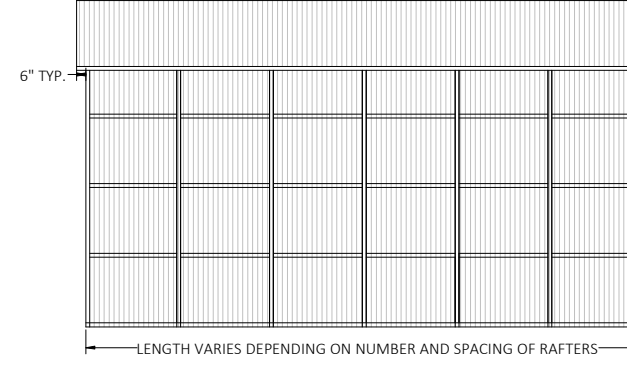

TYPICAL SIDE ELEVATION - VERTICAL ROOF/SIDING OPTION

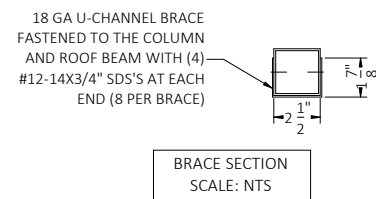

BRACE SECTION SCALE: NTS

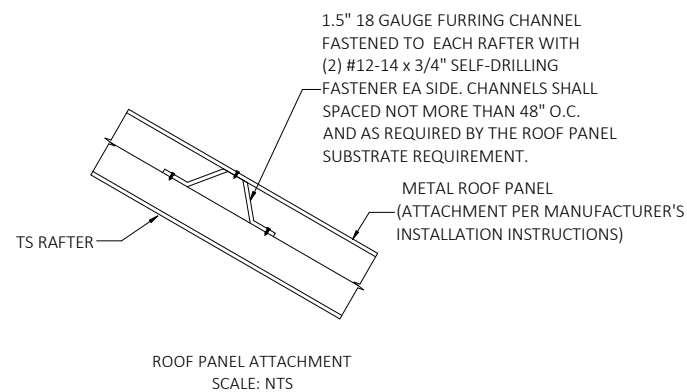

ROOF PANEL ATTACHMENT SCALE: NTS

1.5" 18 GAUGE FURRING CHANNEL FASTENED TO EACH RAFTER WITH (2) #12-14 x 3/4" SELF-DRILLING FASTENER EA SIDE. CHANNELS SHALL SPACED NOT MORE THAN 48" O.C. AND AS REQUIRED BY THE ROOF PANEL SUBSTRATE REQUIREMENT.

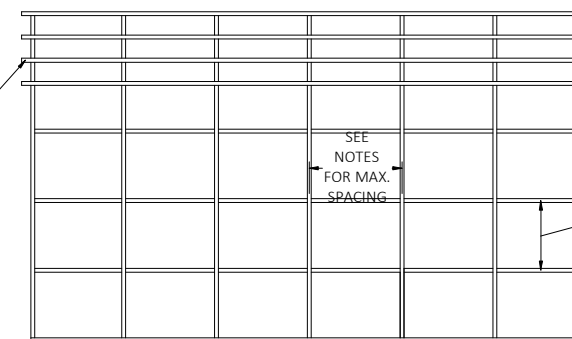

TYPICAL FRAMING SECTION - VERTICAL ROOF/SIDING OPTION

1.5" 18 GAUGE FURRING CHANNEL FASTENED TO EACH POST WITH (2) #12-14 x 3/4" SELF-DRILLING FASTENER EA SIDE. CHANNELS SHALL SPACED NOT MORE THAN 48" O.C. AND AS REQUIRED BY THE WALL PANEL SUBSTRATE REQUIREMENT.

This item has been digitally signed and sealed by Richard E. Walker, P.E. on the date adjacent to the seal. Printed copies of this document are not considered signed and sealed and the signature must be verified on any electronic copies.

FLORIDA ENGINEERING LLC
 4161 TAMiami TRAIL, UNIT 101
 PORT CHARLOTTE, FLORIDA 33952
 (941) 391-5980
 FLEng.com
 Orders@FLEng.com

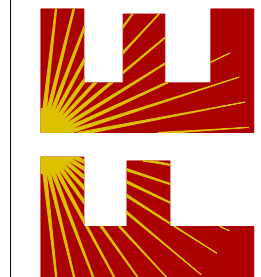

CA CERT. #30782

PROJECT NO. 2504211-30-E

CONTRACTOR:
 TUBULAR BUILDING SYSTEMS
 631 SE INDUSTRIAL CIRCLE,
 LAKE CITY, FL 32025

PROJECT DESCRIPTION:
 30' WIDE X 20' HIGH
 ENCLOSED STRUCTURE

DESIGN DATE: 03/27/2025

REVISION 1: DATE

PAGE :

REVISION 2: DATE

5

SCALE: NTS

BOX EAVE RAFTER LEAN-TO OPTIONS

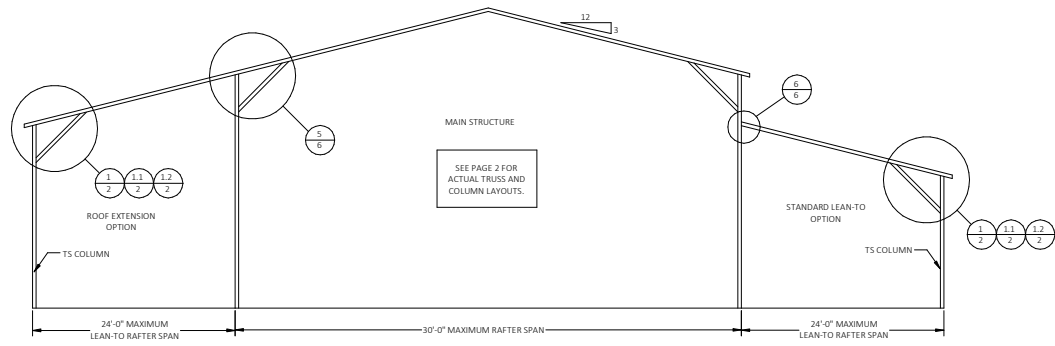

TYPICAL BOX EAVE RAFTER LEAN-TO OPTIONS FRAMING SECTION (BOTH OPTIONS SHOWN)

BOW RAFTER LEAN-TO OPTIONS

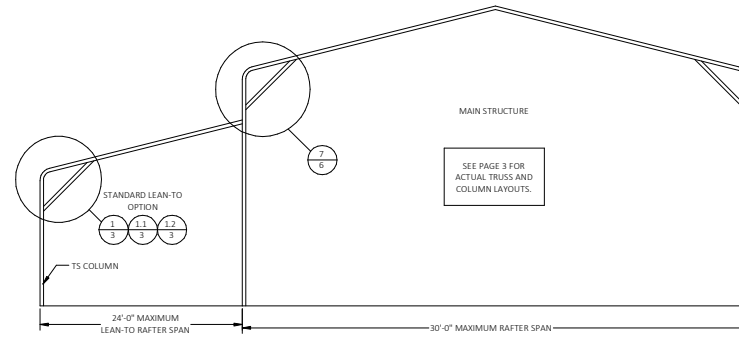

TYPICAL BOW RAFTER LEAN-TO OPTIONS FRAMING SECTION

This item has been digitally signed and sealed by Richard E. Walker, P.E. on the date adjacent to the seal. Printed copies of this document are not considered signed and sealed and the signature must be verified on any electronic copies.

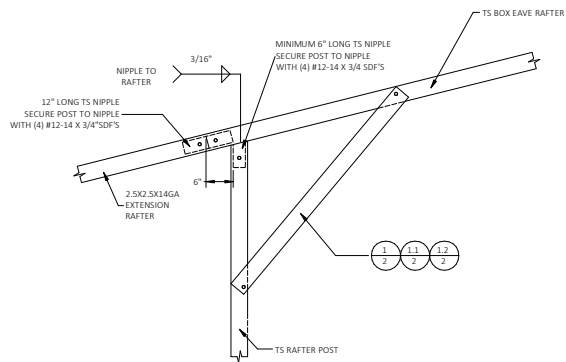

5A SIDE EXTENSION RAFTER/COLUMN DETAIL FOR EXTENSION RAFTER SPANS $W \leq 12'-0"$, IF THE KNEE BRACE ON THE OTHER END OF THE RAFTER IS PER DETAIL 1.1/2. FOR EXTENSION RAFTER SPANS $W \leq 13'-0"$, IF THE KNEE BRACE ON THE OTHER END OF THE RAFTER IS PER DETAIL 1.1/3. FOR EXTENSION RAFTER SPANS $W < 15'-0"$, IF THE KNEE BRACE ON THE OTHER END OF THE RAFTER IS PER DETAIL 1/2. SCALE: NTS

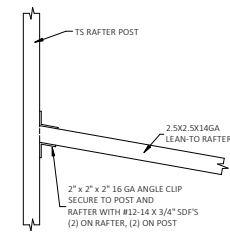

6A LEAN-TO RAFTER TO RAFTER COLUMN CONNECTION DETAIL FOR LEAN-TO RAFTER SPANS $W \leq 12'-0"$, IF THE KNEE BRACE ON THE OTHER END OF THE RAFTER IS PER DETAIL 1.1/2 OR 1.2/3. FOR LEAN-TO RAFTER SPANS $W \leq 13'-0"$, IF THE KNEE BRACE ON THE OTHER END OF THE RAFTER IS PER DETAIL 1.1/2 OR 1.1/3. FOR LEAN-TO RAFTER SPANS $W < 15'-0"$, IF THE KNEE BRACE ON THE OTHER END OF THE RAFTER IS PER DETAIL 1/2 OR 1/3. SCALE: NTS

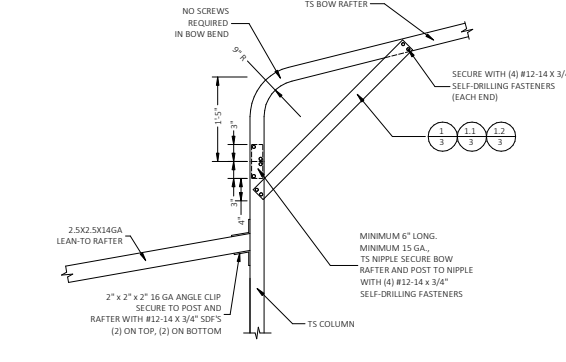

7A SIDE EXTENSION RAFTER/COLUMN DETAIL FOR EXTENSION RAFTER SPANS $W \leq 12'-0"$, IF THE KNEE BRACE ON THE OTHER END OF THE RAFTER IS PER DETAIL 1.1/2. FOR EXTENSION RAFTER SPANS $W \leq 13'-0"$, IF THE KNEE BRACE ON THE OTHER END OF THE RAFTER IS PER DETAIL 1.1/3. FOR EXTENSION RAFTER SPANS $W < 15'-0"$, IF THE KNEE BRACE ON THE OTHER END OF THE RAFTER IS PER DETAIL 1/3. SCALE: NTS

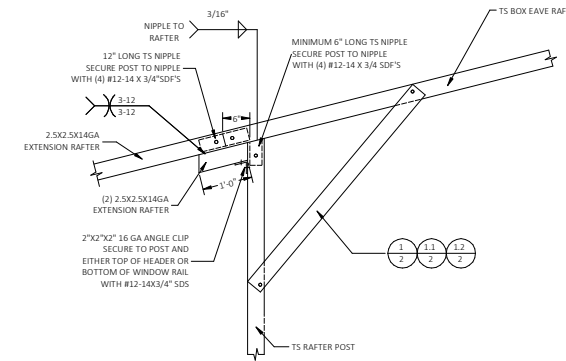

5B SIDE EXTENSION RAFTER/COLUMN DETAIL FOR EXTENSION RAFTER SPANS $12'-0" < W \leq 16'-0"$, IF THE KNEE BRACE ON THE OTHER END OF THE RAFTER IS PER DETAIL 1.1/2. FOR EXTENSION RAFTER SPANS $13'-0" < W \leq 18'-0"$, IF THE KNEE BRACE ON THE OTHER END OF THE RAFTER IS PER DETAIL 1.1/3. FOR EXTENSION RAFTER SPANS $15'-0" < W < 19'-0"$, IF THE KNEE BRACE ON THE OTHER END OF THE RAFTER IS PER DETAIL 1/2. SCALE: NTS

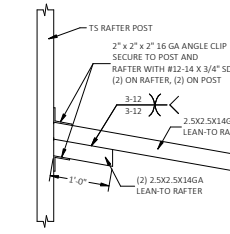

6B LEAN-TO RAFTER TO RAFTER COLUMN CONNECTION DETAIL FOR LEAN-TO RAFTER SPANS $12'-0" < W \leq 16'-0"$, IF THE KNEE BRACE ON THE OTHER END OF THE RAFTER IS PER DETAIL 1.1/2 OR 1.2/3. FOR LEAN-TO RAFTER SPANS $13'-0" < W \leq 18'-0"$, IF THE KNEE BRACE ON THE OTHER END OF THE RAFTER IS PER DETAIL 1.1/2 OR 1.1/3. FOR LEAN-TO RAFTER SPANS $15'-0" < W < 19'-0"$, IF THE KNEE BRACE ON THE OTHER END OF THE RAFTER IS PER DETAIL 1/2 OR 1/3. SCALE: NTS

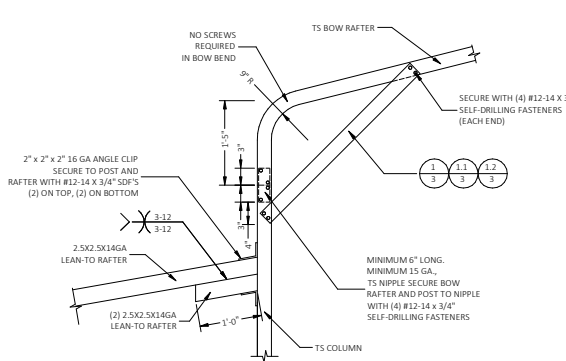

7B SIDE EXTENSION RAFTER/COLUMN DETAIL FOR EXTENSION RAFTER SPANS $12'-0" < W \leq 16'-0"$, IF THE KNEE BRACE ON THE OTHER END OF THE RAFTER IS PER DETAIL 1.1/2. FOR EXTENSION RAFTER SPANS $13'-0" < W \leq 18'-0"$, IF THE KNEE BRACE ON THE OTHER END OF THE RAFTER IS PER DETAIL 1.1/3. FOR EXTENSION RAFTER SPANS $15'-0" < W < 19'-0"$, IF THE KNEE BRACE ON THE OTHER END OF THE RAFTER IS PER DETAIL 1/3. SCALE: NTS

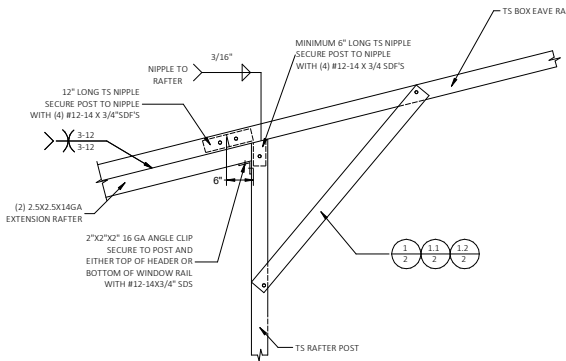

5C SIDE EXTENSION RAFTER/COLUMN DETAIL FOR EXTENSION RAFTER SPANS $16'-0" < W \leq 24'-0"$, IF THE KNEE BRACE ON THE OTHER END OF THE RAFTER IS PER DETAIL 1.1/2. FOR EXTENSION RAFTER SPANS $18'-0" < W \leq 24'-0"$, IF THE KNEE BRACE ON THE OTHER END OF THE RAFTER IS PER DETAIL 1.1/3. FOR EXTENSION RAFTER SPANS $19'-0" < W < 24'-0"$, IF THE KNEE BRACE ON THE OTHER END OF THE RAFTER IS PER DETAIL 1/2. SCALE: NTS

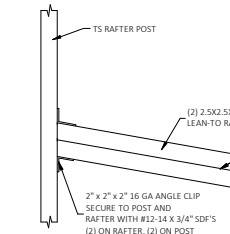

6C LEAN-TO RAFTER TO RAFTER COLUMN CONNECTION DETAIL FOR LEAN-TO RAFTER SPANS $16'-0" < W \leq 24'-0"$, IF THE KNEE BRACE ON THE OTHER END OF THE RAFTER IS PER DETAIL 1.1/2 OR 1.2/3. FOR LEAN-TO RAFTER SPANS $18'-0" < W \leq 24'-0"$, IF THE KNEE BRACE ON THE OTHER END OF THE RAFTER IS PER DETAIL 1.1/2 OR 1.1/3. FOR LEAN-TO RAFTER SPANS $19'-0" < W < 24'-0"$, IF THE KNEE BRACE ON THE OTHER END OF THE RAFTER IS PER DETAIL 1/2 OR 1/3. SCALE: NTS

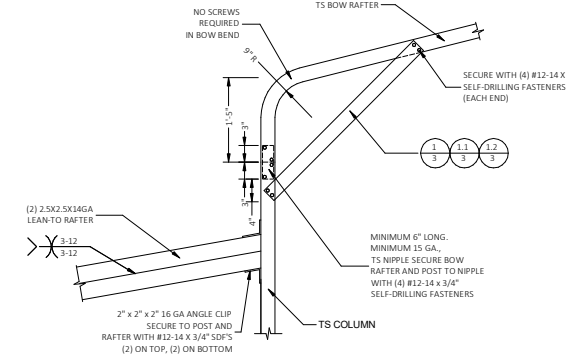

7C SIDE EXTENSION RAFTER/COLUMN DETAIL FOR EXTENSION RAFTER SPANS $16'-0" < W \leq 24'-0"$, IF THE KNEE BRACE ON THE OTHER END OF THE RAFTER IS PER DETAIL 1.1/2. FOR EXTENSION RAFTER SPANS $18'-0" < W \leq 24'-0"$, IF THE KNEE BRACE ON THE OTHER END OF THE RAFTER IS PER DETAIL 1.1/3. FOR EXTENSION RAFTER SPANS $19'-0" < W < 24'-0"$, IF THE KNEE BRACE ON THE OTHER END OF THE RAFTER IS PER DETAIL 1/3. SCALE: NTS

FLORIDA ENGINEERING LLC
 4161 TAMiami TRAIL, UNIT 101
 PORT CHARLOTTE, FLORIDA 33952
 (941) 391-5980
 FLEng.com
 Orders@FLEng.com

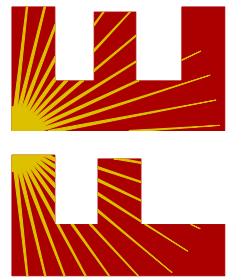

CA CERT. #30782

PROJECT NO. 2504211-30-E

CONTRACTOR:
TUBULAR BUILDING SYSTEMS
 631 SE INDUSTRIAL CIRCLE,
 LAKE CITY, FL 32025

PROJECT DESCRIPTION:
**30' WIDE X 20' HIGH
 ENCLOSED STRUCTURE**

DESIGN DATE: 03/27/2025

REVISION 1:	DATE	PAGE: 6
REVISION 2:	DATE	
SCALE:	NTS	

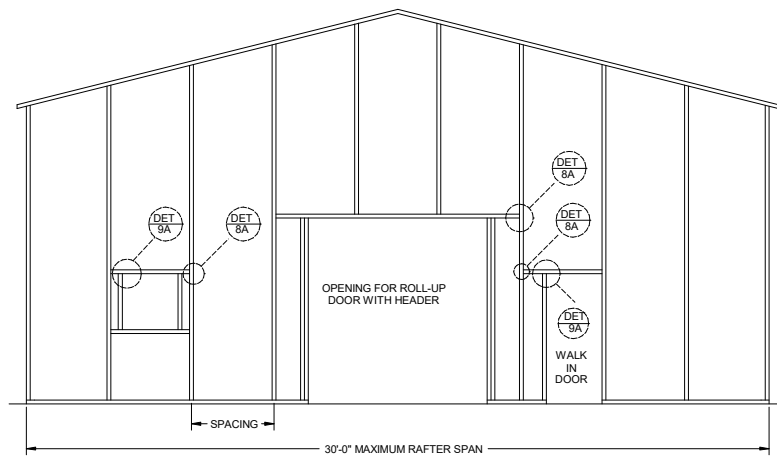

SPACING = 5'-0" FOR WIND SPEEDS BETWEEN 110 MPH AND 150 MPH
 SPACING = 4'-0" FOR WIND SPEEDS BETWEEN 150 MPH AND 180 MPH
 TYPICAL BOX EAVE RAFTER END WALL FRAMING SECTION

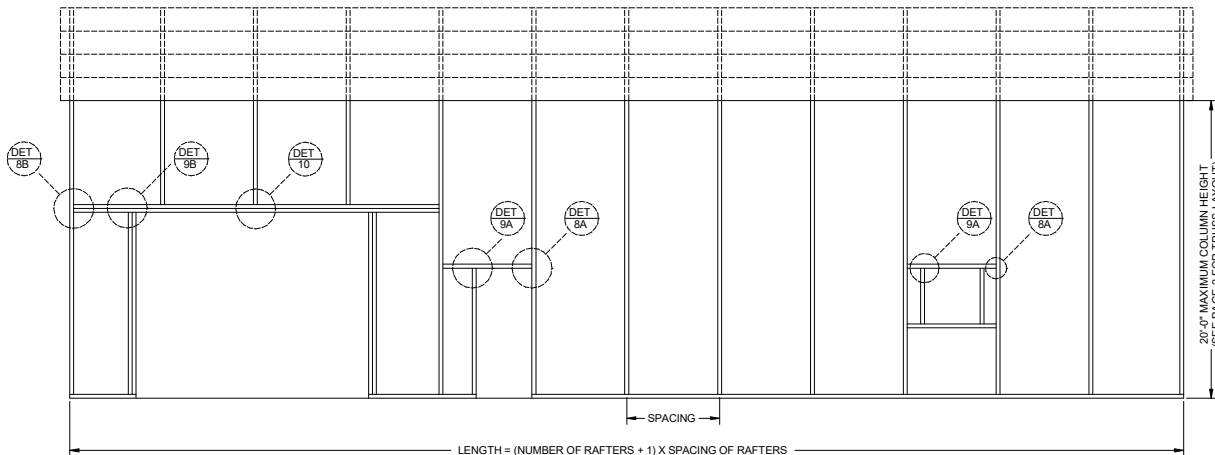

LENGTH = (NUMBER OF RAFTERS + 1) X SPACING OF RAFTERS
 SPACING = 5'-0" FOR WIND SPEEDS BETWEEN 110 MPH AND 150 MPH
 SPACING = 4'-0" FOR WIND SPEEDS BETWEEN 150 MPH AND 180 MPH
 TYPICAL BOX EAVE RAFTER SIDE WALL FRAMING SECTION

This item has been digitally signed and sealed by Richard E. Walker, P.E. on the date adjacent to the seal. Printed copies of this document are not considered signed and sealed and the signature must be verified on any electronic copies.

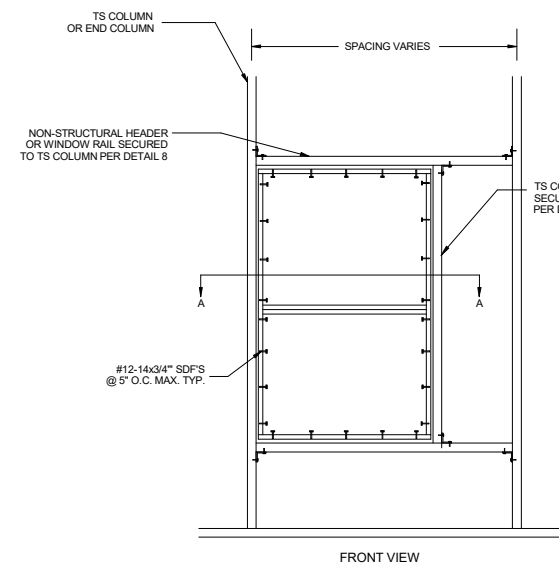
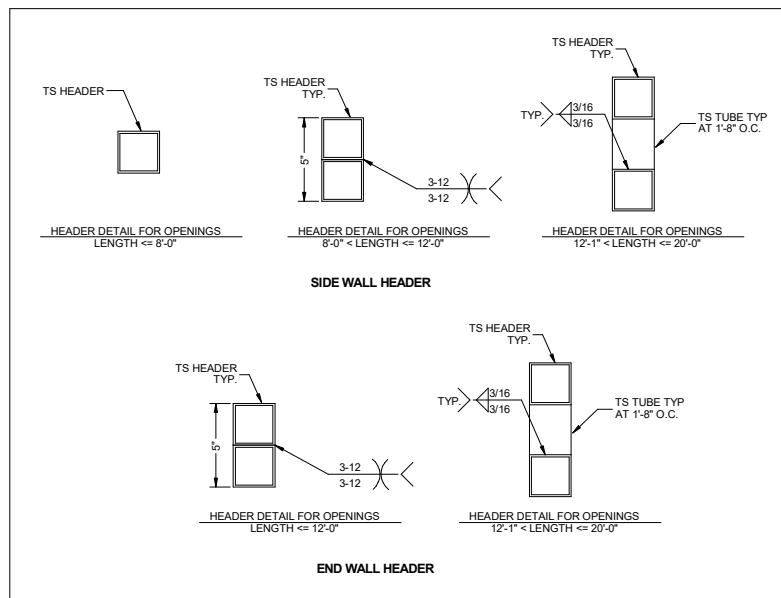
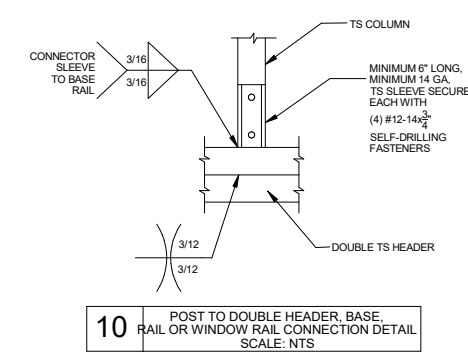
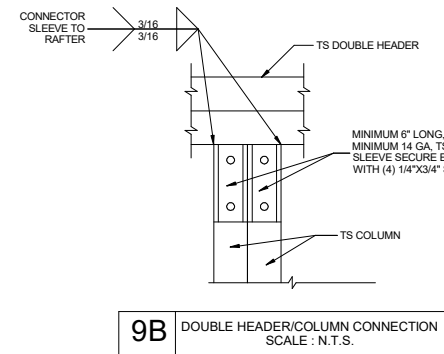
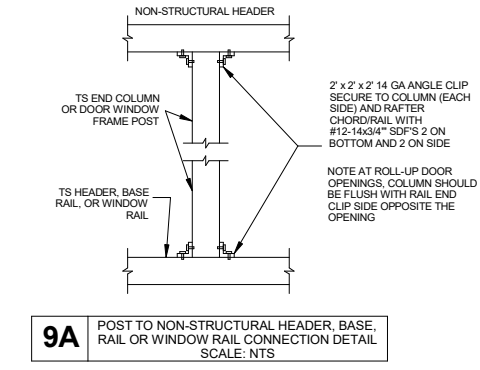
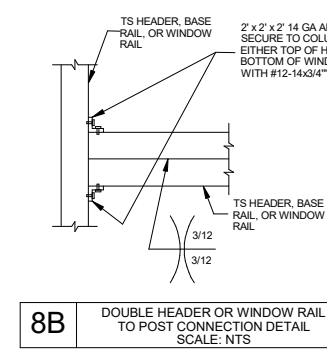
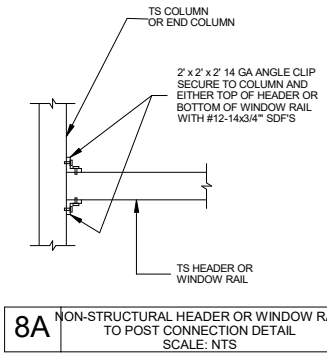

11 WINDOW INSTALLATION DETAILS
 N.T.S.

FLORIDA ENGINEERING LLC
 4161 TAMiami TRAIL, UNIT 101
 PORT CHARLOTTE, FLORIDA 33952
 (941) 391-5980
 FLEng.com
 Orders@FLEng.com

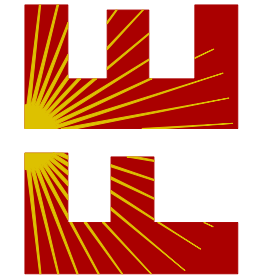

CA CERT. #30782

PROJECT NO. 2504211-30-E

CONTRACTOR:
 TUBULAR BUILDING SYSTEMS
 631 SE INDUSTRIAL CIRCLE,
 LAKE CITY, FL 32025

PROJECT DESCRIPTION:
 30' WIDE X 20' HIGH
 ENCLOSED STRUCTURE

DESIGN DATE: 03/27/2025
 REVISION 1: DATE
 REVISION 2: DATE
 SCALE: N.T.S.

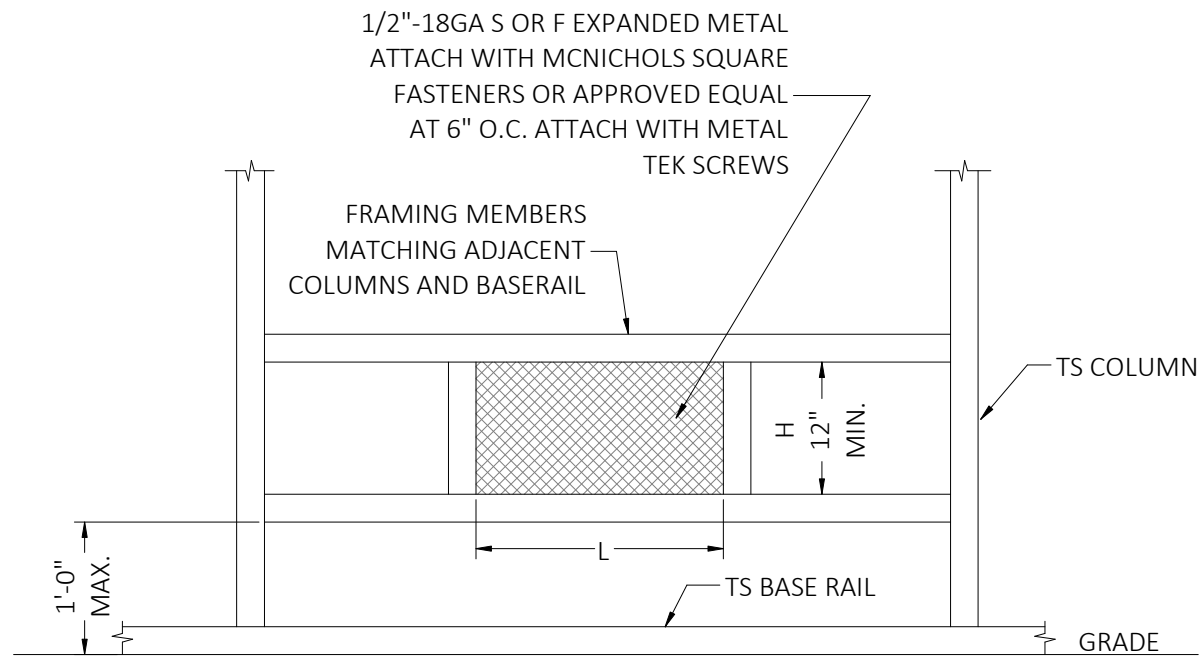

TYPICAL FLOOD VENT DETAIL

CONSTRUCTION IN SPECIAL FLOOD HAZARD AREAS:

CONTRACTOR TO VERIFY THAT THE FINISHED FLOOR ELEVATION FOR THE PROPOSED STRUCTURE IS AT OR ABOVE THE GREATER OF THE FOLLOWING ELEVATIONS:

- I) BFE (BASE FLOOD ELEVATION) + 2'-0"
- II) DFE (DESIGN FLOOD ELEVATION)
- III) THE MINIMUM ELEVATION MANDATED BY THE BUILDING CODES ADOPTED BY THE AUTHORITY HAVING JURISDICTION.

FLOOD VENT INSTALLATION NOTES:

- 1. MINIMUM VENT SPACE REQUIRED = 1 SQ. IN. OF OPEN VENT AREA PER SQ. FT. OF ENCLOSED AREA.
- 2. PROVIDE A MINIMUM OF TWO OPENINGS ON DIFFERENT SIDES OF EACH ENCLOSED AREA.
- 3. APPLY A 1.3 FACTOR WHEN CALCULATING TOTAL OPEN AREA WHEN USING 1/2"-18GA S OR F EXPANDED METAL.
- 4. TOTAL OPEN AREA OF VENT = L X H (MIN. 12").
- 5. FLOOD VENT DETAIL COMPLIES WITH FEMA/NFIP.
- 6. PREFABRICATED FLOOD VENTS MEETING THE REQUIREMENTS OF FEMA/NFIP MAY BE INSTALLED.

FLOOD SOLUTIONS STATIC FLOOD VENTS FL #17588.1-R4				
VENT MODEL	VENT SIZE (WIDTH X HEIGHT) (in.)	ROUGH OPENING SIZE (Width x Height) (in.)	ENCLSOED AREA COVERAGE (sq. ft.)	NET FREE AREA (sq. in.)
FS-1608	18 1/2" X 10 1/2"	16 X 8	97	80.7
FS-1616	18 1/2" X 18 1/2"	16 X 16	191	158.2
FS-1412	17 1/2" X 14 1/2"	14 1/2" X 12"	129	106.7
FS-1608-HEX	18 1/2" X 10 1/2"	16 X 8	110	91.4

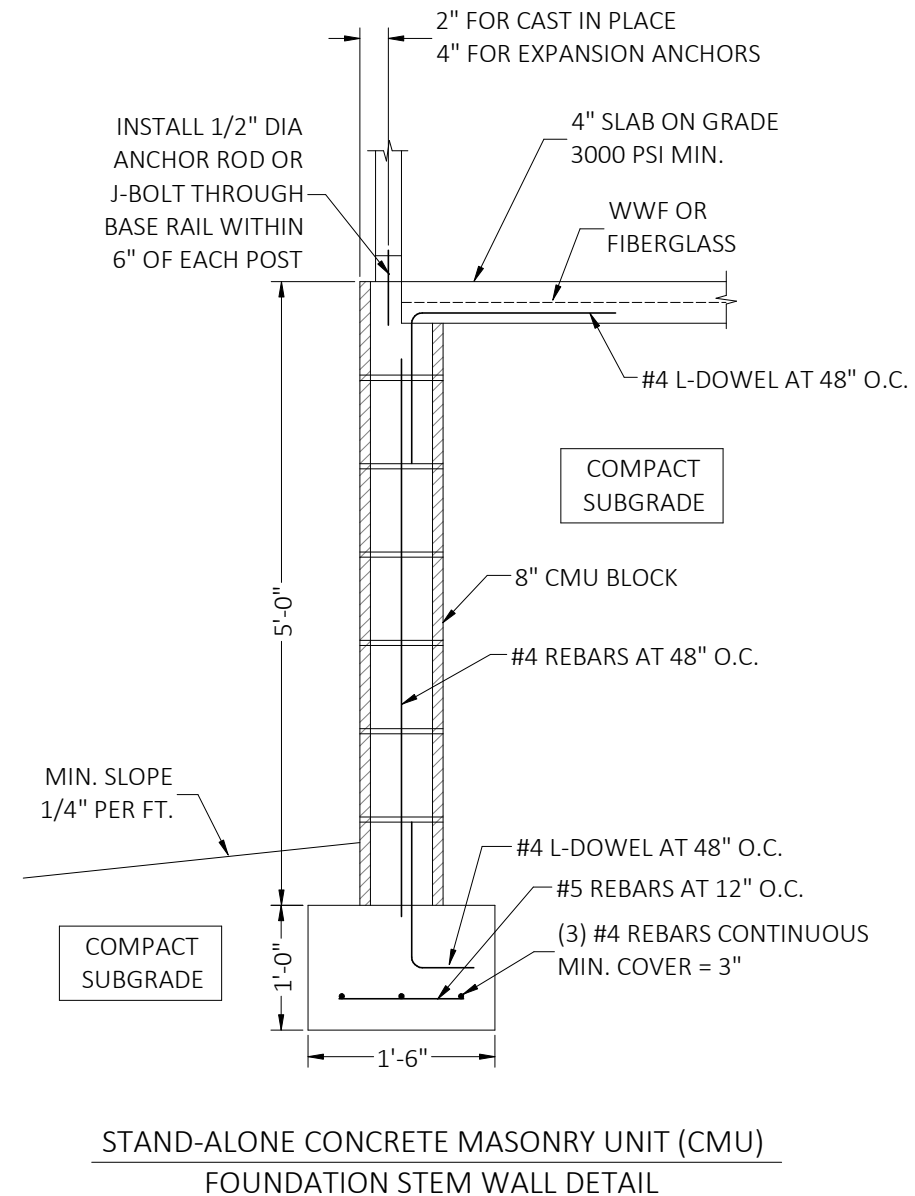

STAND-ALONE CONCRETE MASONRY UNIT (CMU)
FOUNDATION STEM WALL DETAIL

This item has been digitally signed and sealed by Richard E. Walker, P.E. on the date adjacent to the seal. Printed copies of this document are not considered signed and sealed and the signature must be verified on any electronic copies.

FLORIDA ENGINEERING LLC
4161 TAMiami TRAIL, UNIT 101
PORT CHARLOTTE, FLORIDA 33952
(941) 391-5980
FLEng.com
Orders@FLEng.com

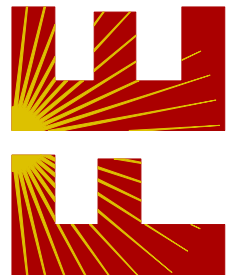

CA CERT. #30782

PROJECT NO. 2504211-30-E

CONTRACTOR:
TUBULAR BUILDING SYSTEMS
631 SE INDUSTRIAL CIRCLE,
LAKE CITY, FL 32025

PROJECT DESCRIPTION:
30' WIDE X 20' HIGH
ENCLOSED STRUCTURE

DESIGN DATE: 03/27/2025

REVISION 1: DATE

REVISION 2: DATE

SCALE: NTS

GENERAL NOTES

CONCRETE MONOLITHIC SLAB DESIGN IS BASED ON A MINIMUM SOIL BEARING CAPACITY OF 1500 PSF.

CONCRETE

MINIMUM 28-DAY SPECIFIED COMPRESSIVE STRENGTH = 3000 PSI

REINFORCING STEEL

1. TURNDOWN REINFORCING STEEL = ASTM A615 GRADE 60
2. SLAB REINFORCEMENT = WELDED WIRE FABRIC PER ASTM A185 OR FIBERGLASS FIBER REINFORCEMENT
3. REINFORCING STEEL COVER = 3" WHERE CASE AGAINST AND PERMANENTLY EXPOSED TO SOIL OR WATER, 1.5" EVERYWHERE ELSE.
4. REINFORCEMENT IS BENT COLD.
5. MINIMUM INSIDE DIAMETER OF BEND = (6) BAR DIAMETERS
6. REINFORCEMENT PARTIALLY EMBEDDED IN CONCRETE SHALL NOT BE FIELD BENT.

OPTIONAL CONCRETE STRIP FOOTING

This item has been digitally signed and sealed by Richard E. Walker, P.E. on the date adjacent to the seal. Printed copies of this document are not considered signed and sealed and the signature must be verified on any electronic copies.

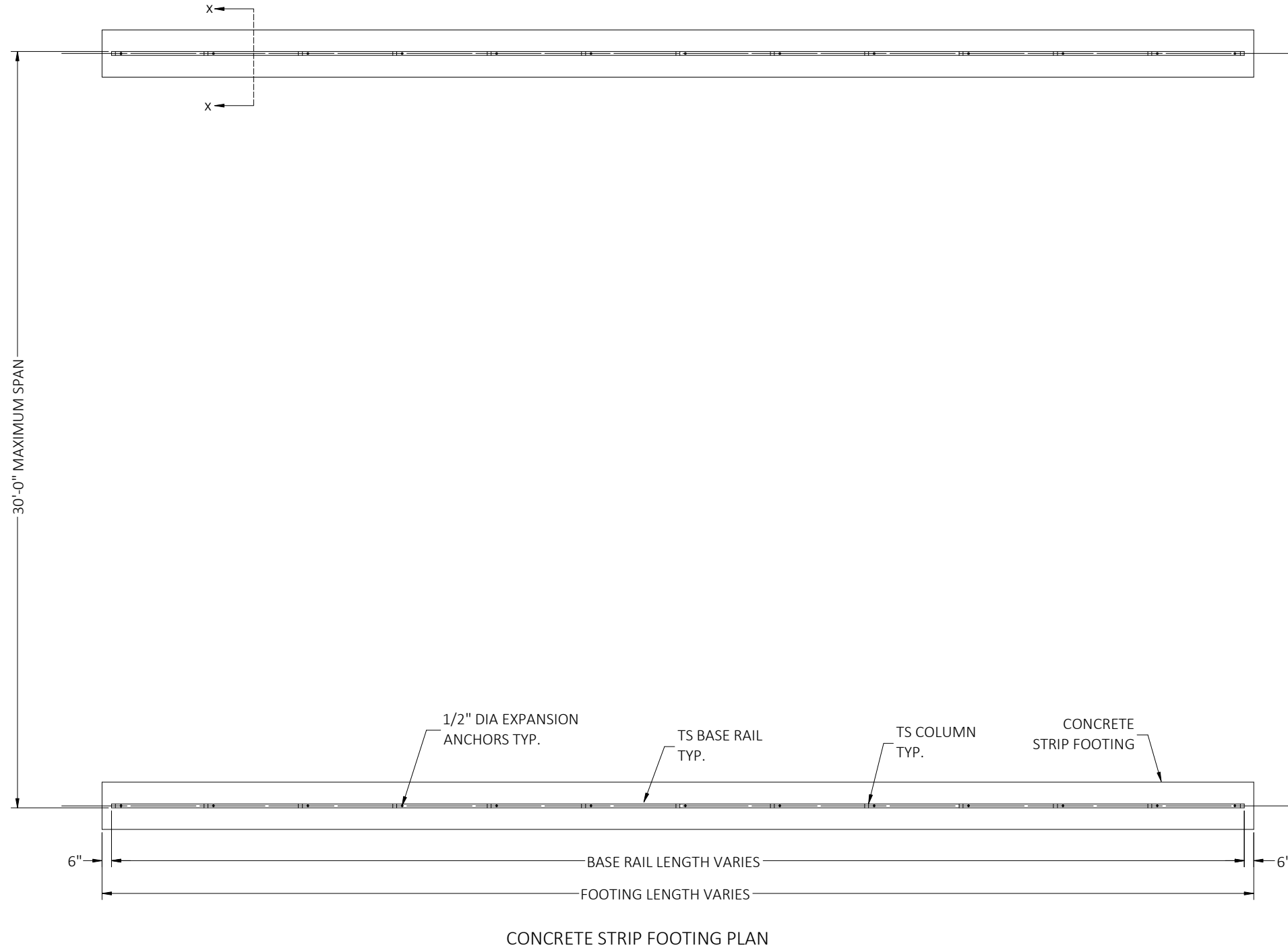
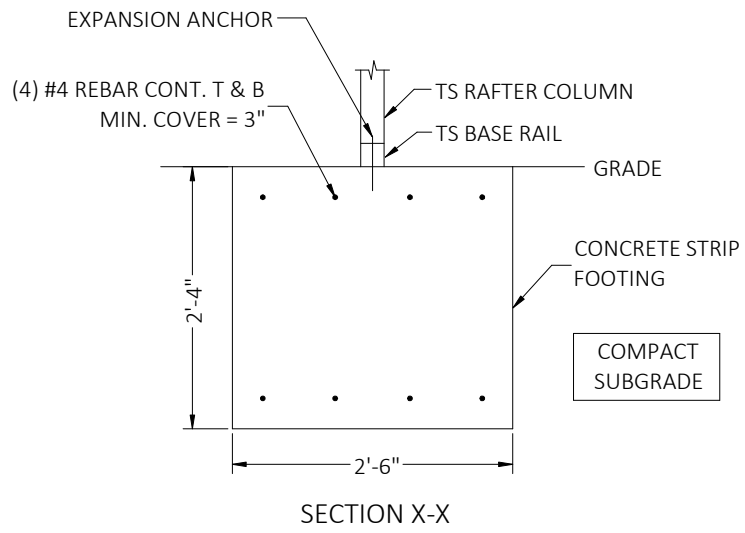

FLORIDA ENGINEERING LLC
 4161 TAMiami TRAIL, UNIT 101
 PORT CHARLOTTE, FLORIDA 33952
 (941) 391-5980
 FLEng.com
 Orders@FLEng.com

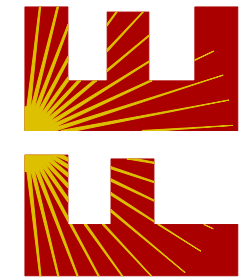

CA CERT. #30782

PROJECT NO. 2504211-30-E

CONTRACTOR:
 TUBULAR BUILDING SYSTEMS
 631 SE INDUSTRIAL CIRCLE,
 LAKE CITY, FL 32025

PROJECT DESCRIPTION:

30' WIDE X 20' HIGH
 ENCLOSED STRUCTURE

DESIGN DATE: 03/27/2025

REVISION 1: DATE

REVISION 2: DATE

SCALE: NTS

PAGE :

9