

COA #0 278  
 Florida Certificate of Product Approval #FL1999  
 02/25/2026

Alpine, an ITW Company  
 155 Harlem Ave  
 North Building, 4th Floor  
 Glenview, IL 60025  
 Phone: (800)755-6001  
 www.alpineitw.com

This item has been digitally signed by Douglas Fleming on the date adjacent to the seal.

Printed copies of this document are not considered signed and sealed and the signature must be verified on any electronic copies.

Site Information:	Page 1:
Customer: W. B. Howland Company, Inc.	Job Number: 26-3388d
Job Description: JOHNSON	
Address: 8355 SW ELIN CHURCH RD, Fort White, FL 32038	

Job Engineering Criteria:	
Design Code: FBC 8th Ed. 2023 Res.	IntelliVIEW Version: 24.02.00D JRef #: 1YHX2150002
Wind Standard: ASCE 7-22      Wind Speed (mph): 130	Design Loading (psf): 40
Building Type: Enclosed	

This package contains general notes pages, 49 truss drawing(s) and 5 detail(s).

Item	Drawing Number	Truss
1	056.26.0825.25350	A1
3	056.26.0825.36517	A1E
5	056.26.0825.46087	A3
7	056.26.0827.43710	B1
9	056.26.0831.17417	B2
11	056.26.0831.54070	C1
13	056.26.0835.53773	C2
15	056.26.0835.45890	C3
17	056.26.0835.34630	FG2
19	056.26.0835.24217	FL1
21	056.26.0835.04927	FL2E
23	056.26.0834.47793	M1
25	056.26.0834.31483	MV1
27	056.26.0834.14747	MV3
29	056.26.0834.11143	MV5
31	056.26.0834.25293	MV12
33	056.26.0834.21817	MV14
35	056.26.0834.18563	MV16
37	056.26.0834.03060	P1E
39	056.26.0833.57750	P2E
41	056.26.0833.52910	P3E
43	056.26.0833.32117	S1
45	056.26.0833.16407	V1
47	056.26.0833.08890	V3
49	056.26.0833.04110	V5

Item	Drawing Number	Truss
2	056.26.0825.29400	A1A
4	056.26.0825.41890	A2
6	056.26.0827.37480	A4
8	056.26.0828.24630	B1E
10	056.26.0831.48000	B3
12	056.26.0835.59190	C1E
14	056.26.0835.49523	C2E
16	056.26.0835.38093	FG1
18	056.26.0835.29673	FG3
20	056.26.0835.18097	FL2
22	056.26.0834.53423	FL3
24	056.26.0834.34617	MG1
26	056.26.0834.16547	MV2
28	056.26.0834.12873	MV4
30	056.26.0834.29240	MV11
32	056.26.0834.23617	MV13
34	056.26.0834.20167	MV15
36	056.26.0834.05580	P1
38	056.26.0834.00320	P2
40	056.26.0833.55033	P3
42	056.26.0833.50633	P4
44	056.26.0833.29230	T1
46	056.26.0833.10890	V2
48	056.26.0833.06120	V4
50	BRCLBSUB0119	

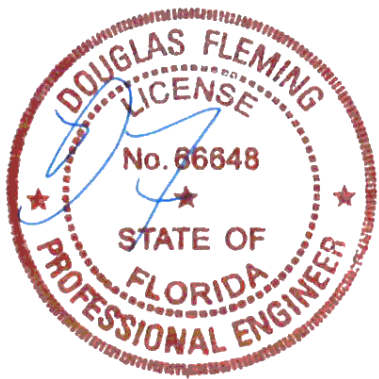

Alpine, an ITW Company  
155 Harlem Ave  
North Building, 4th Floor  
Glenview, IL 60025  
Phone: (800)755-6001  
www.alpineitw.com

COA #0 278  
Florida Certificate of Product Approval #FL1999  
02/25/2026

This item has been digitally signed by Douglas Fleming on the date adjacent to the seal.

Printed copies of this document are not considered signed and sealed and the signature must be verified on any electronic copies.

Site Information:	Page 2:
Customer: W. B. Howland Company, Inc.	Job Number: 26-3388d
Job Description: JOHNSON	
Address: 8355 SW ELIN CHURCH RD, Fort White, FL 32038	

Item	Drawing Number	Truss
51	VAL180220723	
53	PB160220723	

Item	Drawing Number	Truss
52	VALTN220723	
54	STRBRIBR1014	

## **General Notes**

### **Truss Design Engineer Scope of Work, Design Assumptions and Design Responsibilities:**

The design responsibilities assumed in the preparation of these design drawings are those specified in ANSI/TPI 1, Chapter 2; and the National Design Standard for Metal Plate Connected Wood Truss Construction, by the Truss Plate Institute. The truss component designs conform to the applicable provisions of ANSI/TPI 1 and NDS, the National Design Specification for Wood Construction by AWC. The truss component designs are based on the specified loading and dimension information furnished by others to the Truss Design Engineer. The Truss Design Engineer has no duty to independently verify the accuracy or completeness of the information provided by others and may rely on that information without liability. The responsibility for verification of that information remains with others neither employed nor controlled by the Truss Design Engineer. The Truss Design Engineer's seal and signature on the attached drawings, or cover page listing these drawings, indicates acceptance of professional engineering responsibility solely for the truss component designs and not for the technical information furnished by others which technical information and consequences thereof remain their sole responsibility.

The suitability and use of these drawings for any particular structure is the responsibility of the Building Designer in accordance with ANSI/TPI 1 Chapter 2. The Building Designer is responsible for determining that the dimensions and loads for each truss component match those required by the plans and by the actual use of the individual component, and for ascertaining that the loads shown on the drawings meet or exceed applicable building code requirements and any additional factors required in the particular application. Truss components using metal connector plates with integral teeth shall not be placed in environments that will cause the moisture content of the wood in which plates are embedded to exceed 19% and/or cause corrosion of connector plates and other metal fasteners.

The Truss Design Engineer shall not be responsible for items beyond the specific scope of the agreed contracted work set forth herein, including but not limited to: verifying the dimensions of the truss component, calculation of any of the truss component design loads, inspection of the truss components before or after installation, the design of temporary or permanent bracing and their attachment required in the roof and/or floor systems, the design of diaphragms or shear walls, the design of load transfer connections to and from diaphragms and shear walls, the design of load transfer to the foundation, the design of connections for truss components to their bearing supports, the design of the bearing supports, installation of the truss components, observation of the truss component installation process, review of truss assembly procedures, sequencing of the truss component installation, construction means and methods, site and/or worker safety in the installation of the truss components and/or its connections.

This document may be a high-quality facsimile of the original engineering document which is a digitally signed electronic file with third party authentication. A wet or embossed seal copy of this engineering document is available upon request.

### **Temporary Lateral Restraint and Bracing:**

Temporary lateral restraint and diagonal bracing shall be installed according to the provisions of BCSI chapters B1, B2, B7 and/or B10 (Building Component Safety Information, by TPI and SBCA), or as specified by the Building Designer or other Registered Design Professional. The required locations for lateral restraint and/or bracing depicted on these drawings are only for the permanent lateral support of the truss members to reduce buckling lengths, and do not apply to and may not be relied upon for the temporary stability of the truss components during their installation.

### **Permanent Lateral Restraint and Bracing:**

The required locations for lateral restraint or bracing depicted on these drawings are for the permanent lateral support of the truss members to reduce buckling lengths. Permanent lateral support shall be installed according to the provisions of BCSI chapters B3, B7 and/or B10, or as specified by the Building Designer or other Registered Design Professional. These drawings do not depict or specify installation/erection bracing, wind bracing, portal bracing or similar building stability bracing which are parts of the overall building design to be specified, designed, and detailed by the Building Designer.

### **Connector Plate Information:**

Alpine connector plates are made of ASTM A653 or ASTM A1063 galvanized steel with the following designations, gauges and grades: W=Wave, 20ga, grade 40; H=High Strength, 20ga, grade 60; S=Super Strength, 18ga, grade 60. Information on model code compliance is contained in the ICC Evaluation Service report ESR-1118, available on-line at [www.icc-es.org](http://www.icc-es.org).

### **Bearing Information:**

The bearing area factor,  $C_b$ , is considered for the allowable capacity of solid sawn wood bearings supporting trusses that are located a minimum of 3" from the end of the lumber piece.

## **General Notes** (continued)

### **Coated Lumber:**

Coated lumber must be properly re-dried and maintained below 19% or less moisture level through all stages of construction and usage. Coated lumber has no adjustments to lumber properties. Coated lumber may be more brittle than uncoated lumber. Special handling care must be taken to prevent breakage during all handling activities. Refer to manufacturer literature, specifications, and code evaluation reports for restrictions, details, and requirements.

### **Fire Retardant Treated Lumber:**

Fire retardant treated lumber must be properly re-dried and maintained below 19% or less moisture level through all stages of construction and usage. Fire retardant treated lumber may be more brittle than untreated lumber. Special handling care must be taken to prevent breakage during all handling activities.

### **Key to Terms:**

Information provided on drawings reflects a summary of the pertinent information required for the truss design. Detailed information on load cases, reactions, member lengths, forces and members requiring permanent lateral support may be found in calculation sheets available upon written request.

BCDL = Bottom Chord standard design Dead Load in pounds per square foot.

BCLL = Bottom Chord standard design Live Load in pounds per square foot.

C = Coated lumber.

C-AT = AtTEK coated lumber.

C-FX = FX Lumber Guard coated lumber.

C -TE = TechWood 4400 coated lumber.

CL = Certified lumber.

Des Ld = total of TCLL, TCDL, BCLL and BCDL Design Load in pounds per square foot.

FRT = Fire Retardant Treated lumber.

FRT-BF = Borafire Fire Retardant Treated lumber

FRT-DB = D-Blaze Fire Retardant Treated lumber.

FRT-DC = Dricon Fire Retardant Treated lumber.

FRT-FP = FirePRO Fire Retardant Treated lumber.

FRT-FL = FlamePRO Fire Retardant Treated lumber.

FRT-FT = FlameTech Fire Retardant Treated lumber.

FRT-ON = OnWood Fire Retardant Treated lumber.

FRT-PG = PYRO-GUARD Fire Retardant Treated lumber.

FRT-PR = ProWood Fire Retardant Treated lumber.

g = green lumber.

HORZ(LL) = maximum Horizontal panel point deflection due to Live Load, in inches.

HORZ(TL) = maximum Horizontal panel point long term deflection in inches, due to Total Load, including creep adjustment.

HPL = additional Horizontal Load added to a truss Piece in pounds per linear foot or pounds.

Ic = Incised lumber.

FJ = Finger Jointed lumber.

L/# = user specified divisor for limiting span/deflection ratio for evaluation of actual L/defl value.

L/defl = ratio of Length between bearings, in inches, divided by the vertical Deflection due to creep, in inches, at the referenced panel point. Reported as 999 if greater than or equal to 999.

Loc = Location, starting location of left end of bearing or panel point (joint) location of deflection.

Max BC CSI = Maximum bending and axial Combined Stress Index for Bottom Chords for all load cases.

Max TC CSI = Maximum bending and axial Combined Stress Index for Top Chords for all load cases.

Max Web CSI = Maximum bending and axial Combined Stress Index for Webs for all load cases.

NCBCLL = Non-Concurrent Bottom Chord design Live Load in pounds per square foot.

PL = additional Load applied at a user specified angle on a truss Piece in pounds per linear foot or pounds.

PLB = additional vertical load added to a Bottom chord Piece of a truss in pounds per linear foot or pounds

PLT = additional vertical load added to a Top chord Piece of a truss in pounds per linear foot or pounds.

PP = Panel Point.

R = maximum downward design Reaction, in pounds, from all specified gravity load cases, at the indicated location (Loc).

-R = maximum upward design Reaction, in pounds, from all specified gravity load cases, at the identified location (Loc).

Rh = maximum horizontal design Reaction in either direction, in pounds, from all specified gravity load cases, at the indicated location (Loc).

RL = maximum horizontal design Reaction in either direction, in pounds, from all specified non-gravity (wind or seismic) load cases, at the indicated location (Loc).

## **General Notes** (continued)

### **Key to Terms** (continued):

Rw = maximum downward design Reaction, in pounds, from all specified non-gravity (wind or seismic) load cases, at the identified location (Loc).

TCDL = Top Chord standard design Dead Load in pounds per square foot.

TCLL = Top Chord standard design Live Load in pounds per square foot.

U = maximum Upward design reaction, in pounds, from all specified non-gravity (wind or seismic) load cases, at the indicated location (Loc).

VERT(CL) = maximum Vertical panel point deflection in inches due to Live Load and Creep Component of Dead Load in inches.

VERT(CTL) = maximum Vertical panel point deflection ratios due to Live Load and Creep Component of Dead Load, and maximum long term Vertical panel point deflection in inches due to Total load, including creep adjustment.

VERT(LL) = maximum Vertical panel point deflection in inches due to Live Load.

VERT(TL) = maximum Vertical panel point long term deflection in inches due to Total load, including creep adjustment.

W = Width of non-hanger bearing, in inches.

Refer to ASCE-7 for Wind and Seismic abbreviations.

Uppercase Acronyms not explained above are as defined in TPI 1.

### **References:**

1. AWC: American Wood Council; 222 Catoclin Circle SE, Suite 201; Leesburg, VA 20175; [www.awc.org](http://www.awc.org).
2. ICC: International Code Council; [www.iccsafe.org](http://www.iccsafe.org).
3. Alpine, a division of ITW Building Components Group Inc.: 155 Harlem Ave, North Building, 4th Floor, Glenview, IL 60025; [www.alpineitw.com](http://www.alpineitw.com).
4. TPI: Truss Plate Institute, 2670 Crain Highway, Suite 203, Waldorf, MD 20601; [www.tpinst.org](http://www.tpinst.org).
5. SBCA: Wood Truss Council of America, 6300 Enterprise Lane, Madison, WI 53719; [www.sbcacomponents.com](http://www.sbcacomponents.com)

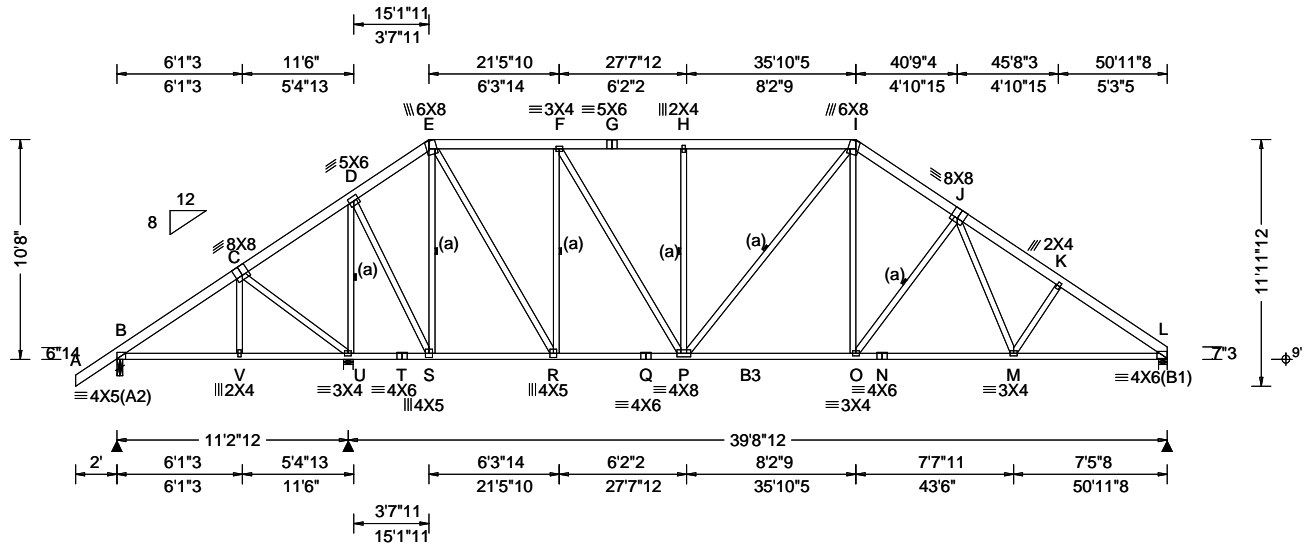

<b>Loading Criteria (psf)</b> TCLL: 20.00 TCDL: 10.00 BCLL: 0.00 BCDL: 10.00 Des Ld: 40.00 NCBCLL: 10.00 Soffit: 2.00 Load Duration: 1.25 Spacing: 24.0 "	<b>Wind Criteria</b> Wind Std: ASCE 7-22 Speed: 130 mph Enclosure: Enclosed Risk Category: II EXP: C Kzt: NA Mean Height: 17.41 ft TCDL: 5.0 psf BCDL: 5.0 psf MWFRS Parallel Dist: 0 to h/2 C&C Dist a: 5.10 ft Loc. from endwall: Any GCp: 0.18 Wind Duration: 1.60	<b>Snow Criteria (Pg,Pf in PSF)</b> Pg: NA Ct: NA CAT: NA Pf: NA Ce: NA Lu: NA Cs: NA Snow Duration: NA  Building Code: FBC 8th Ed. 2023 Res. TPI Std: 2014 Rep Fac: Yes FT/RT:20(0)/10(0) Plate Type(s): WAVE	<b>Defl/CSI Criteria</b> PP Deflection in loc L/defl L/# VERT(LL): 0.123 O 999 360 VERT(CL): 0.226 O 999 240 HORZ(LL): 0.057 L - - HORZ(TL): 0.104 L - - Creep Factor: 2.0 Max TC CSI: 0.539 Max BC CSI: 0.786 Max Web CSI: 0.769  VIEW Ver: 24.02.00D.0114.10	<b>▲ Maximum Reactions (lbs)</b> Gravity Loc R+ / R- / Rh / Rw / U / RL Non-Gravity B 525 -/ - /282 /93 /511 U 2611 -/ - /1480 /312 -/ L 1920 -/ - /1085 /232 -/ Wind reactions based on MWFRS B Brg Wid = 3.5 Min Req = 1.5 (Truss) U Brg Wid = 5.5 Min Req = 2.7 (Truss) L Brg Wid = 5.0 Min Req = 2.3 (Truss) Bearings B, U, & L are a rigid surface. Members not listed have forces less than 375# <b>Maximum Top Chord Forces Per Ply (lbs)</b> Chords Tens.Comp. Chords Tens. Comp.
--	--	--	---	---

<b>Lumber</b> Top chord: 2x6 SP #2; Bot chord: 2x4 SP #2; B3 2x4 SP M-31; Webs: 2x4 SP #3;	<b>Maximum Bot Chord Forces Per Ply (lbs)</b> Chords Tens.Comp. Chords Tens. Comp. D - E 334 -837 H - I 755 -1887 E - F 613 -1440 I - J 599 -2315 F - G 768 -1886 J - K 664 -2787 G - H 768 -1886 K - L 627 -2959
---	--

<b>Bracing</b> (a) Continuous lateral restraint equally spaced on member.	<b>Maximum Web Forces Per Ply (lbs)</b> Webs Tens.Comp. Webs Tens. Comp. C - U 228 -426 R - F 298 -1097 U - D 445 -2271 F - P 832 -162 D - S 1627 -155 H - P 199 -480 E - S 192 -1266 I - O 761 -150 E - R 1585 -277 O - J 285 -466
--	---

<b>Loading</b> Truss passed check for 20 psf additional bottom chord live load in areas with 42"-high x 24"-wide clearance.	<b>Maximum Top Chord Forces Per Ply (lbs)</b> Chords Tens.Comp. Chords Tens. Comp. B - V 441 -259 P - O 1863 -107 V - U 441 -260 O - N 2138 -275 S - R 643 -106 N - M 2138 -275 R - Q 1470 -11 M - L 2343 -427 Q - P 1470 -11
--	---

<b>Wind</b> Wind loads based on MWFRS with additional C&C member design. Wind loading based on both gable and hip roof types.	<b>Maximum Web Forces Per Ply (lbs)</b> Webs Tens.Comp. Webs Tens. Comp. C - U 228 -426 R - F 298 -1097 U - D 445 -2271 F - P 832 -162 D - S 1627 -155 H - P 199 -480 E - S 192 -1266 I - O 761 -150 E - R 1585 -277 O - J 285 -466
---	---

**Additional Notes**  
WARNING: Furnish a copy of this DWG to the installation contractor. Special care must be taken during handling, shipping and installation of trusses. See "WARNING" note below.  
The overall height of this truss excluding overhang is 10-8-0.

COA #0 278  
Florida Certificate of Product Approval #FL1999  
02/25/2026

**\*\*WARNING\*\* READ AND FOLLOW ALL NOTES ON THIS DRAWING!**  
**\*\*IMPORTANT\*\* FURNISH THIS DRAWING TO ALL CONTRACTORS INCLUDING THE INSTALLERS**  
Trusses require extreme care in fabricating, handling, shipping, installing and bracing. Refer to and follow the latest edition of BCSI (Building Component Safety Information, by TPI and SBCA) for safety practices prior to performing these functions. Installers shall provide temporary bracing per BCSI. Unless noted otherwise, top chord shall have properly attached structural sheathing and bottom chord shall have a properly attached rigid ceiling. Locations shown for permanent lateral restraint of webs shall have continuous lateral restraint (CLR), installed with diagonal bracing installed on the CLR per BCSI sections B3, B7, or B10, as applicable. Apply plates to each face of truss and position as shown above and on the Joint Details, unless noted otherwise. Refer to drawings 160A-Z for standard plate positions. Refer to job's General Notes page for additional information.  
Alpine, a division of ITW Building Components Group Inc. shall not be responsible for any deviation from this drawing, any failure to build the truss in conformance with ANSI/TPI 1, or for handling, shipping, installation and bracing of trusses. A seal on this drawing or cover page listing this drawing, indicates acceptance of professional engineering responsibility solely for the design shown. The suitability and use of this drawing for any structure is the responsibility of the Building Designer per ANSI/TPI 1 Sec.2.  
For more information see these web sites: Alpine: alpineitw.com; TPI: tpinst.org; SBCA: sbccomponents.com; ICC: iccsafe.org; AWC: awc.org

155 Harlem Ave  
 North Building, 4th Floor  
 Glenview, IL 60025

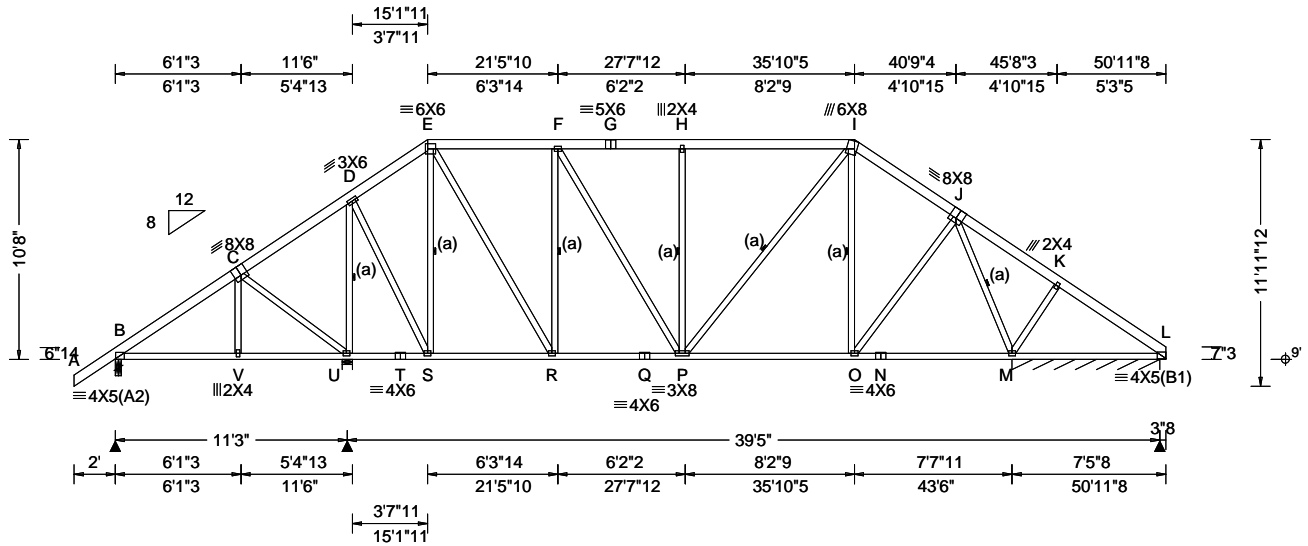

<b>Loading Criteria (psf)</b> TCLL: 20.00 TCCL: 10.00 BCLL: 0.00 BCDL: 10.00 Des Ld: 40.00 NCBCLL: 10.00 Soffit: 2.00 Load Duration: 1.25 Spacing: 24.0 "	<b>Wind Criteria</b> Wind Std: ASCE 7-22 Speed: 130 mph Enclosure: Enclosed Risk Category: II EXP: C Kzt: NA Mean Height: 17.41 ft TCCL: 5.0 psf BCDL: 5.0 psf MWFRS Parallel Dist: h/2 to h C&C Dist a: 5.10 ft Loc. from endwall: not in 13.00 ft GCp: 0.18 Wind Duration: 1.60	<b>Snow Criteria (Pg,Pf in PSF)</b> Pg: NA Ct: NA CAT: NA Pf: NA Ce: NA Lu: NA Cs: NA Snow Duration: NA Building Code: FBC 8th Ed. 2023 Res. TPI Std: 2014 Rep Fac: Yes FT/RT:20(0)/10(0) Plate Type(s): WAVE	<b>Defl/CSI Criteria</b> PP Deflection in loc L/defl L/# VERT(LL): 0.048 H 999 360 VERT(CL): 0.099 H 999 240 HORZ(LL): 0.018 L - - HORZ(TL): 0.038 L - - Creep Factor: 2.0 Max TC CSI: 0.300 Max BC CSI: 0.582 Max Web CSI: 0.475 VIEW Ver: 24.02.00D.0114.10	<b>▲ Maximum Reactions (lbs), or *PLF</b> <table style="width:100%; border-collapse: collapse;"> <thead> <tr> <th rowspan="2">Loc</th> <th colspan="3">Gravity</th> <th colspan="3">Non-Gravity</th> </tr> <tr> <th>R+</th> <th>/R-</th> <th>/Rh</th> <th>/Rw</th> <th>/U</th> <th>/RL</th> </tr> </thead> <tbody> <tr> <td>B</td> <td>659</td> <td>-</td> <td>-</td> <td>/368</td> <td>/112</td> <td>/511</td> </tr> <tr> <td>U</td> <td>1751</td> <td>-</td> <td>-</td> <td>/1256</td> <td>/233</td> <td>-</td> </tr> <tr> <td>M*</td> <td>282</td> <td>-</td> <td>-</td> <td>/183</td> <td>/40</td> <td>-</td> </tr> </tbody> </table> <p>Wind reactions based on MWFRS          B Brg Wid = 3.5 Min Req = 1.5 (Truss)          U Brg Wid = 6.0 Min Req = 2.1 (Truss)          M Brg Wid = 86.0 Min Req = -          Bearings B, U, &amp; M are a rigid surface.          Members not listed have forces less than 375#  <b>Maximum Top Chord Forces Per Ply (lbs)</b>  <table style="width:100%; border-collapse: collapse;"> <thead> <tr> <th>Chords</th> <th>Tens.Comp.</th> <th>Chords</th> <th>Tens. Comp.</th> </tr> </thead> <tbody> <tr> <td>B - C</td> <td>146 -565</td> <td>G - H</td> <td>528 -1101</td> </tr> <tr> <td>D - E</td> <td>271 -689</td> <td>H - I</td> <td>522 -1102</td> </tr> <tr> <td>E - F</td> <td>456 -951</td> <td>I - J</td> <td>275 -1007</td> </tr> <tr> <td>F - G</td> <td>528 -1101</td> <td></td> <td></td> </tr> </tbody> </table> </p>	Loc	Gravity			Non-Gravity			R+	/R-	/Rh	/Rw	/U	/RL	B	659	-	-	/368	/112	/511	U	1751	-	-	/1256	/233	-	M*	282	-	-	/183	/40	-	Chords	Tens.Comp.	Chords	Tens. Comp.	B - C	146 -565	G - H	528 -1101	D - E	271 -689	H - I	522 -1102	E - F	456 -951	I - J	275 -1007	F - G	528 -1101		
Loc	Gravity			Non-Gravity																																																						
	R+	/R-	/Rh	/Rw	/U	/RL																																																				
B	659	-	-	/368	/112	/511																																																				
U	1751	-	-	/1256	/233	-																																																				
M*	282	-	-	/183	/40	-																																																				
Chords	Tens.Comp.	Chords	Tens. Comp.																																																							
B - C	146 -565	G - H	528 -1101																																																							
D - E	271 -689	H - I	522 -1102																																																							
E - F	456 -951	I - J	275 -1007																																																							
F - G	528 -1101																																																									

**Lumber**

Top chord: 2x6 SP #2;  
 Bot chord: 2x4 SP #2;  
 Webs: 2x4 SP #3;

**Bracing**

(a) Continuous lateral restraint equally spaced on member.

**Plating Notes**

All plates are 3X4 except as noted.

**Wind**

Wind loads based on MWFRS with additional C&C member design.  
 Right cantilever is exposed to wind  
 Wind loading based on both gable and hip roof types.

**Additional Notes**

WARNING: Furnish a copy of this DWG to the installation contractor. Special care must be taken during handling, shipping and installation of trusses. See "WARNING" note below.  
 The overall height of this truss excluding overhang is 10-8-0.

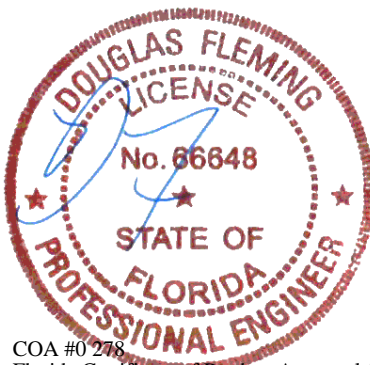

COA #0 278  
 Florida Certificate of Product Approval #FL1999  
 02/25/2026

**\*\*WARNING\*\* READ AND FOLLOW ALL NOTES ON THIS DRAWING!**  
**\*\*IMPORTANT\*\* FURNISH THIS DRAWING TO ALL CONTRACTORS INCLUDING THE INSTALLERS**  
 Trusses require extreme care in fabricating, handling, shipping, installing and bracing. Refer to and follow the latest edition of BCSI (Building Component Safety Information, by TPI and SBCA) for safety practices prior to performing these functions. Installers shall provide temporary bracing per BCSI. Unless noted otherwise, top chord shall have properly attached structural sheathing and bottom chord shall have a properly attached rigid ceiling. Locations shown for permanent lateral restraint of webs shall have continuous lateral restraint (CLR), installed with diagonal bracing installed on the CLR per BCSI sections B3, B7, or B10, as applicable. Apply plates to each face of truss and position as shown above and on the Joint Details, unless noted otherwise. Refer to drawings 160A-Z for standard plate positions. Refer to job's General Notes page for additional information.  
 Alpine, a division of ITW Building Components Group Inc. shall not be responsible for any deviation from this drawing, any failure to build the truss in conformance with ANSI/TPI 1, or for handling, shipping, installation and bracing of trusses. A seal on this drawing or cover page listing this drawing, indicates acceptance of professional engineering responsibility solely for the design shown. The suitability and use of this drawing for any structure is the responsibility of the Building Designer per ANSI/TPI 1 Sec.2.  
 For more information see these web sites: Alpine: alpineitw.com; TPI: tpinst.org; SBCA: sbccomponents.com; ICC: iccsafe.org; AWC: awc.org



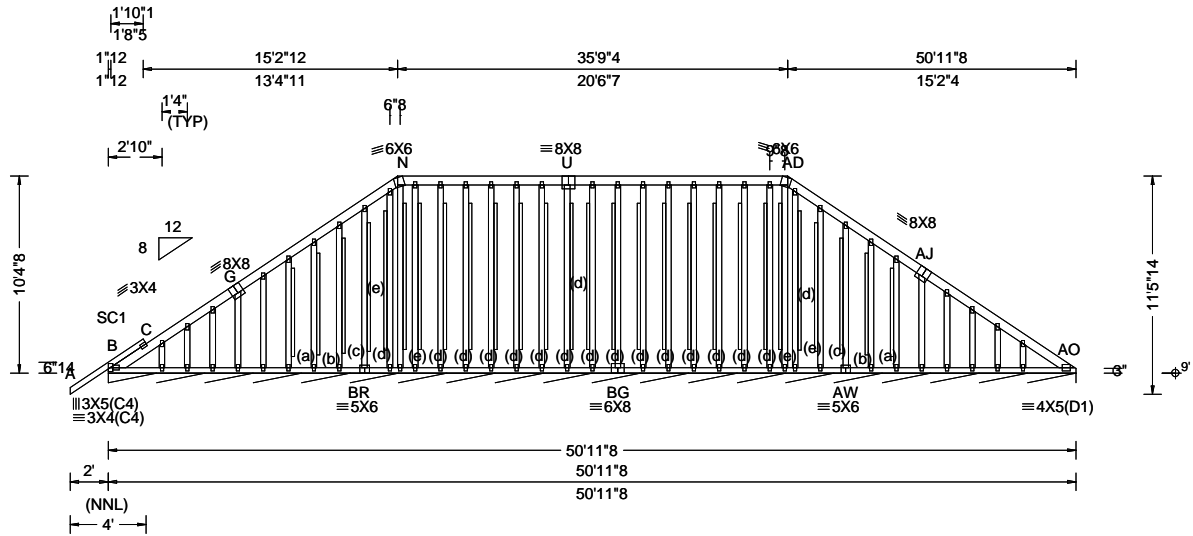

<b>Loading Criteria (psf)</b> TCCL: 20.00 TCCL: 10.00 BCLL: 0.00 BCDL: 10.00 Des Ld: 40.00 NCBCLL: 10.00 Soffit: 2.00 Load Duration: 1.25 Spacing: 24.0 "	<b>Wind Criteria</b> Wind Std: ASCE 7-22 Speed: 130 mph Enclosure: Enclosed Risk Category: II EXP: C Kzt: NA Mean Height: 17.41 ft TCCL: 5.0 psf BCDL: 5.0 psf MWFRS Parallel Dist: 0 to h/2 C&C Dist a: 5.10 ft Loc. from endwall: Any GCp: 0.18 Wind Duration: 1.60	<b>Snow Criteria (Pg,Pf in PSF)</b> Pg: NA Ct: NA CAT: NA Pf: NA Ce: NA Lu: NA Cs: NA Snow Duration: NA  Building Code: FBC 8th Ed. 2023 Res. TPI Std: 2014 Rep Fac: Varies by Ld Case FT/RT:20(0)/10(0) Plate Type(s): WAVE	<b>Defl/CSI Criteria</b> PP Deflection in loc L/defl L/# VERT(LL): 0.001 V 999 360 VERT(CL): 0.004 V 999 240 HORZ(LL): -0.001 AO - - HORZ(TL): 0.013 AI - - Creep Factor: 2.0 Max TC CSI: 0.551 Max BC CSI: 0.160 Max Web CSI: 0.991  VIEW Ver: 24.02.00D.0114.10	<b>▲ Maximum Reactions (lbs), or *=PLF</b> <table border="1"> <thead> <tr> <th colspan="3">Gravity</th> <th colspan="3">Non-Gravity</th> </tr> <tr> <th>Loc</th> <th>R+</th> <th>/ R-</th> <th>/ Rh</th> <th>/ Rw</th> <th>/ U</th> <th>/ RL</th> </tr> </thead> <tbody> <tr> <td>B*</td> <td>179</td> <td>-</td> <td>-</td> <td>/54</td> <td>/26</td> <td>/9</td> </tr> </tbody> </table>	Gravity			Non-Gravity			Loc	R+	/ R-	/ Rh	/ Rw	/ U	/ RL	B*	179	-	-	/54	/26	/9
				Gravity			Non-Gravity																	
Loc	R+	/ R-	/ Rh	/ Rw	/ U	/ RL																		
B*	179	-	-	/54	/26	/9																		
Wind reactions based on MWFRS B Brg Wid = 611 Min Req = - Bearing B is a rigid surface. Members not listed have forces less than 375# <b>Maximum Top Chord Forces Per Ply (lbs)</b> <table border="1"> <thead> <tr> <th>Chords</th> <th>Tens.Comp.</th> <th>Chords</th> <th>Tens. Comp.</th> </tr> </thead> <tbody> <tr> <td>B - C</td> <td>725</td> <td>-902</td> <td>U - AD 421 -69</td> </tr> <tr> <td>G - N</td> <td>462</td> <td>-205</td> <td>AD-AJ 462 -75</td> </tr> <tr> <td>N - U</td> <td>421</td> <td>-70</td> <td></td> </tr> </tbody> </table>				Chords	Tens.Comp.	Chords	Tens. Comp.	B - C	725	-902	U - AD 421 -69	G - N	462	-205	AD-AJ 462 -75	N - U	421	-70						
Chords	Tens.Comp.	Chords	Tens. Comp.																					
B - C	725	-902	U - AD 421 -69																					
G - N	462	-205	AD-AJ 462 -75																					
N - U	421	-70																						

**Lumber**

Top chord: 2x6 SP #2;  
 Bot chord: 2x4 SP #2;  
 Webs: 2x4 SP #3;  
 Stack Chord: SC1 2x4 SP #2;

**Plating Notes**

All plates are 2X4 except as noted.

**Loading**

Truss designed to support 1-4-0 top chord outlookers and cladding load not to exceed 5.00 PSF one face and 24.0" span opposite face. Top chord must not be cut or notched, unless specified otherwise.

**Purlins**

In lieu of structural panels use purlins to brace all sloping TC @ 24" oc; all flat TC @ 0" oc.

**Wind**

Wind loads based on MWFRS with additional C&C member design.

Wind loading based on both gable and hip roof types.

Gable meets L/120 deflection criteria for wind load applied to face. Calculated deflection ratio is L/230.

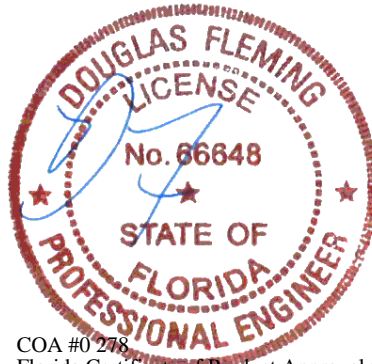

COA #0 278  
 Florida Certificate of Product Approval #FL1999  
 02/25/2026

**\*\*WARNING\*\* READ AND FOLLOW ALL NOTES ON THIS DRAWING!**  
**\*\*IMPORTANT\*\* FURNISH THIS DRAWING TO ALL CONTRACTORS INCLUDING THE INSTALLERS**  
 Trusses require extreme care in fabricating, handling, shipping, installing and bracing. Refer to and follow the latest edition of BCSI (Building Component Safety Information, by TPI and SBCA) for safety practices prior to performing these functions. Installers shall provide temporary bracing per BCSI. Unless noted otherwise, top chord shall have properly attached structural sheathing and bottom chord shall have a properly attached rigid ceiling. Locations shown for permanent lateral restraint of webs shall have continuous lateral restraint (CLR), installed with diagonal bracing installed on the CLR per BCSI sections B3, B7, or B10, as applicable. Apply plates to each face of truss and position as shown above and on the Joint Details, unless noted otherwise. Refer to drawings 160A-Z for standard plate positions. Refer to job's General Notes page for additional information.  
 Alpine, a division of ITW Building Components Group Inc. shall not be responsible for any deviation from this drawing, any failure to build the truss in conformance with ANSI/TPI 1, or for handling, shipping, installation and bracing of trusses. A seal on this drawing or cover page listing this drawing, indicates acceptance of professional engineering responsibility solely for the design shown. The suitability and use of this drawing for any structure is the responsibility of the Building Designer per ANSI/TPI 1 Sec.2.  
 For more information see these web sites: Alpine: alpineitw.com; TPI: tpinst.org; SBCA: sbcacomponents.com; ICC: iccsafe.org; AWC: awc.org



SEQN: 728209	GABL	Ply: 1	Job Number: 26-3388d	Cust: R 215	JRef: 1YHX2150002	T54
FROM: RFG		Qty: 1	JOHNSON	DrwNo: 056.26.0825.36517		
Page 2 of 2			Truss Label: A1E	JB / DF		02/25/2026

**Gable Reinforcement**

- (a) 2x3 "L" reinforcement. Same species and grade as web. 80% length of web member. Attach with 10d (0.131"x3",min.) nails @ 2" oc at each end for the first 18" and then 4" oc for the remainder.
- (b) 2x4 "L" reinforcement. Any species and grade. 80% length of web member. Attach with 10d (0.131"x3",min.) nails @ 2" oc at each end for the first 18" and then 4" oc for the remainder.
- (c) 2x4 SP/DF #2 or better "L" reinforcement. 80% length of web member. Attach with 10d (0.131"x3",min.) nails @ 2" oc at each end for the first 18" and then 4" oc for the remainder.
- (d) 2x6 "L" reinforcement. Any species and grade. 80% length of web member. Attach with 10d (0.131"x3",min.) nails @ 2" oc at each end for the first 18" and then 4" oc for the remainder.
- (e) 2x4 "L" reinforcement. Same species and grade as web. 80% length of web member. Attach with 10d (0.131"x3",min.) nails @ 2" oc at each end for the first 18" and then 4" oc for the remainder.

**Additional Notes**

Exposed portion of gable face shall be reinforced with sheathing and the wind pressures shall be transferred into lateral diaphragms. Connections and designs for diaphragms is the responsibility of the Building Designer in accordance with ANSI/TPI 1.

Stacked top chord must NOT be notched or cut in area (NNL). Dropped top chord braced at 24" oc intervals. Attach stacked top chord (SC) to dropped top chord in notchable area using 3x4 tie-plates 24" oc. Center plate on stacked/dropped chord interface, plate length perpendicular to chord length. Splice top chord in notchable area using 3x6.

WARNING: Furnish a copy of this DWG to the installation contractor. Special care must be taken during handling, shipping and installation of trusses. See "WARNING" note below.

The overall height of this truss excluding overhang is 10-4-8.

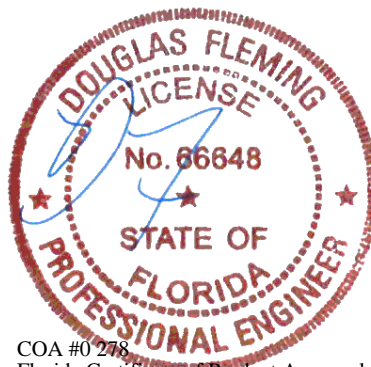

COA #0 278  
 Florida Certificate of Product Approval #FL1999  
 02/25/2026

**\*\*WARNING\*\* READ AND FOLLOW ALL NOTES ON THIS DRAWING!**  
**\*\*IMPORTANT\*\* FURNISH THIS DRAWING TO ALL CONTRACTORS INCLUDING THE INSTALLERS**  
 Trusses require extreme care in fabricating, handling, shipping, installing and bracing. Refer to and follow the latest edition of BCSI (Building Component Safety Information, by TPI and SBCA) for safety practices prior to performing these functions. Installers shall provide temporary bracing per BCSI. Unless noted otherwise, top chord shall have properly attached structural sheathing and bottom chord shall have a properly attached rigid ceiling. Locations shown for permanent lateral restraint of webs shall have continuous lateral restraint (CLR), installed with diagonal bracing installed on the CLR per BCSI sections B3, B7, or B10, as applicable. Apply plates to each face of truss and position as shown above and on the Joint Details, unless noted otherwise. Refer to drawings 160A-Z for standard plate positions. Refer to job's General Notes page for additional information.  
 Alpine, a division of ITW Building Components Group Inc. shall not be responsible for any deviation from this drawing, any failure to build the truss in conformance with ANSI/TPI 1, or for handling, shipping, installation and bracing of trusses. A seal on this drawing or cover page listing this drawing, indicates acceptance of professional engineering responsibility solely for the design shown. The suitability and use of this drawing for any structure is the responsibility of the Building Designer per ANSI/TPI 1 Sec.2.  
 For more information see these web sites: Alpine: [alpineitw.com](http://alpineitw.com); TPI: [tpinst.org](http://tpinst.org); SBCA: [sbcacomponents.com](http://sbcacomponents.com); ICC: [iccsafe.org](http://iccsafe.org); AWC: [awc.org](http://awc.org)



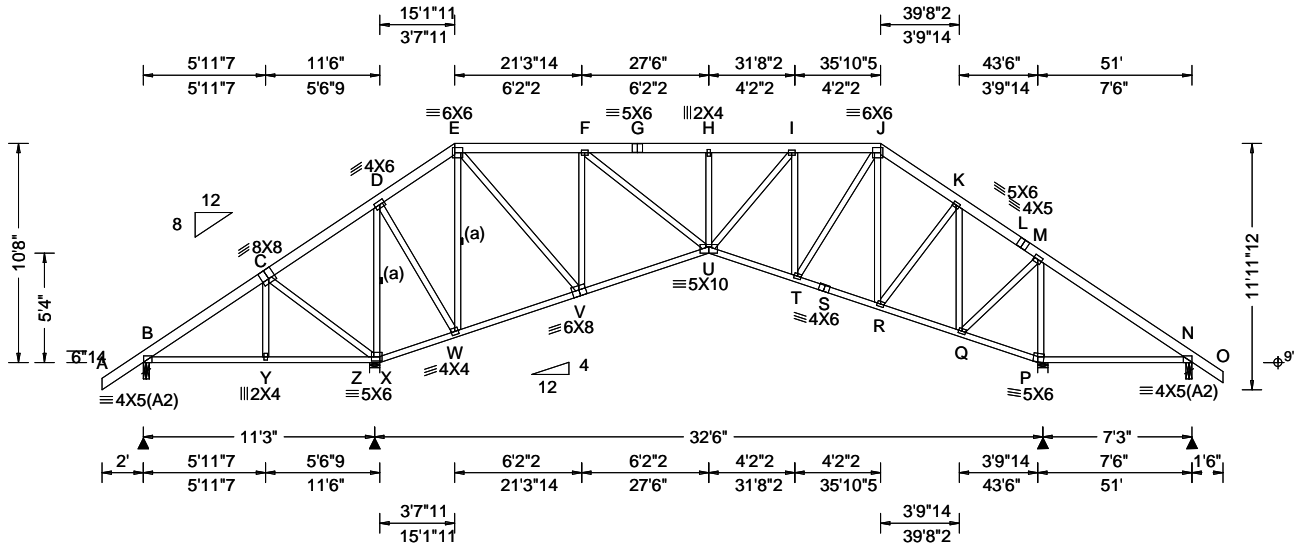

<b>Loading Criteria (psf)</b> TCLL: 20.00 TC DL: 10.00 BCLL: 0.00 BCDL: 10.00 Des Ld: 40.00 NCBCLL: 10.00 Soffit: 2.00 Load Duration: 1.25 Spacing: 24.0 "	<b>Wind Criteria</b> Wind Std: ASCE 7-22 Speed: 130 mph Enclosure: Enclosed Risk Category: II EXP: C Kzt: NA Mean Height: 17.41 ft TC DL: 5.0 psf BCDL: 5.0 psf MWFRS Parallel Dist: h/2 to h C&C Dist a: 5.10 ft Loc. from endwall: not in 13.00 ft GCp: 0.18 Wind Duration: 1.60	<b>Snow Criteria (Pg,Pf in PSF)</b> Pg: NA Ct: NA CAT: NA Pf: NA Ce: NA Lu: NA Cs: NA Snow Duration: NA Building Code: FBC 8th Ed. 2023 Res. TPI Std: 2014 Rep Fac: No FT/RT:20(0)/10(0) Plate Type(s): WAVE	<b>Defl/CSI Criteria</b> PP Deflection in loc L/defl L/# VERT(LL): 0.079 H 999 360 VERT(CL): 0.164 H 999 240 HORZ(LL): 0.057 P - - HORZ(TL): 0.118 P - - Creep Factor: 2.0 Max TC CSI: 0.454 Max BC CSI: 0.410 Max Web CSI: 0.941 VIEW Ver: 24.02.00D.0114.10	<b>▲ Maximum Reactions (lbs)</b> <table style="width:100%; border-collapse: collapse;"> <thead> <tr> <th rowspan="2">Loc</th> <th colspan="3">Gravity</th> <th colspan="3">Non-Gravity</th> </tr> <tr> <th>R+</th> <th>/R-</th> <th>/Rh</th> <th>/Rw</th> <th>/U</th> <th>/RL</th> </tr> </thead> <tbody> <tr> <td>B</td> <td>374</td> <td>-86</td> <td>-</td> <td>/131</td> <td>/119</td> <td>/496</td> </tr> <tr> <td>Z</td> <td>2340</td> <td>-</td> <td>-</td> <td>/1610</td> <td>/244</td> <td>-</td> </tr> <tr> <td>P</td> <td>1945</td> <td>-</td> <td>-</td> <td>/1170</td> <td>/179</td> <td>-</td> </tr> <tr> <td>N</td> <td>288</td> <td>-163</td> <td>-</td> <td>/112</td> <td>/149</td> <td>-</td> </tr> </tbody> </table> <p>Wind reactions based on MWFRS          B Brg Wid = 3.5 Min Req = 1.5 (Truss)          Z Brg Wid = 6.0 Min Req = 2.8 (Truss)          P Brg Wid = 6.0 Min Req = 2.3 (Truss)          N Brg Wid = 3.5 Min Req = 1.5 (Truss)          Bearings B, Z, P, &amp; N are a rigid surface.          Members not listed have forces less than 375#</p>	Loc	Gravity			Non-Gravity			R+	/R-	/Rh	/Rw	/U	/RL	B	374	-86	-	/131	/119	/496	Z	2340	-	-	/1610	/244	-	P	1945	-	-	/1170	/179	-	N	288	-163	-	/112	/149	-
Loc	Gravity			Non-Gravity																																									
	R+	/R-	/Rh	/Rw	/U	/RL																																							
B	374	-86	-	/131	/119	/496																																							
Z	2340	-	-	/1610	/244	-																																							
P	1945	-	-	/1170	/179	-																																							
N	288	-163	-	/112	/149	-																																							

**Lumber**  
 Top chord: 2x6 SP #2;  
 Bot chord: 2x4 SP #2;  
 Webs: 2x4 SP #3;

**Bracing**  
 (a) Continuous lateral restraint equally spaced on member.

**Plating Notes**  
 All plates are 3X4 except as noted.

**Loading**  
 Truss passed check for 20 psf additional bottom chord live load in areas with 42"-high x 24"-wide clearance.

**Wind**  
 Wind loads based on MWFRS with additional C&C member design.  
 Wind loading based on both gable and hip roof types.

**Additional Notes**  
 WARNING: Furnish a copy of this DWG to the installation contractor. Special care must be taken during handling, shipping and installation of trusses. See "WARNING" note below.  
 The overall height of this truss excluding overhang is 10'-8-0.

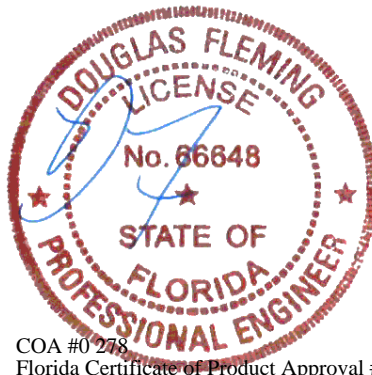

COA #0 278  
 Florida Certificate of Product Approval #FL1999  
 02/25/2026

**Maximum Top Chord Forces Per Ply (lbs)**

Chords	Tens.Comp.	Chords	Tens. Comp.
B - C	490 -172	I - J	388 -1073
C - D	826 -129	J - K	294 -837
E - F	405 -776	K - L	273 -399
F - G	454 -1499	L - M	252 -429
G - H	454 -1499	M - N	655 -8
H - I	440 -1499		

**Maximum Bot Chord Forces Per Ply (lbs)**

Chords	Tens.Comp.	Chords	Tens. Comp.
B - Y	248 -378	T - S	692 0
Y - X	247 -379	S - R	683 0
X - W	223 -691	Q - P	98 -570
V - U	873 -61	P - N	82 -484
U - T	1175 0		

**Maximum Web Forces Per Ply (lbs)**

Webs	Tens.Comp.	Webs	Tens. Comp.
C - X	169 -461	I - T	43 -736
D - X	185 -1759	T - J	793 -2
D - W	1242 -1	R - J	0 -522
E - W	53 -1184	R - K	617 0
E - V	1158 -69	K - Q	34 -950
V - F	139 -999	Q - M	1060 0
F - U	890 0	P - M	261 -1642
U - I	631 -39		

**\*\*WARNING\*\* READ AND FOLLOW ALL NOTES ON THIS DRAWING!**  
**\*\*IMPORTANT\*\* FURNISH THIS DRAWING TO ALL CONTRACTORS INCLUDING THE INSTALLERS**  
 Trusses require extreme care in fabricating, handling, shipping, installing and bracing. Refer to and follow the latest edition of BCSI (Building Component Safety Information, by TPI and SBCA) for safety practices prior to performing these functions. Installers shall provide temporary bracing per BCSI. Unless noted otherwise, top chord shall have properly attached structural sheathing and bottom chord shall have a properly attached rigid ceiling. Locations shown for permanent lateral restraint of webs shall have continuous lateral restraint (CLR), installed with diagonal bracing installed on the CLR per BCSI sections B3, B7, or B10, as applicable. Apply plates to each face of truss and position as shown above and on the Joint Details, unless noted otherwise. Refer to drawings 160A-Z for standard plate positions. Refer to job's General Notes page for additional information.  
 Alpine, a division of ITW Building Components Group Inc. shall not be responsible for any deviation from this drawing, any failure to build the truss in conformance with ANSI/TPI 1, or for handling, shipping, installation and bracing of trusses. A seal on this drawing or cover page listing this drawing, indicates acceptance of professional engineering responsibility solely for the design shown. The suitability and use of this drawing for any structure is the responsibility of the Building Designer per ANSI/TPI 1 Sec.2.  
 For more information see these web sites: Alpine: alpineitw.com; TPI: tpinst.org; SBCA: sbcacomponents.com; ICC: iccsafe.org; AWC: awc.org



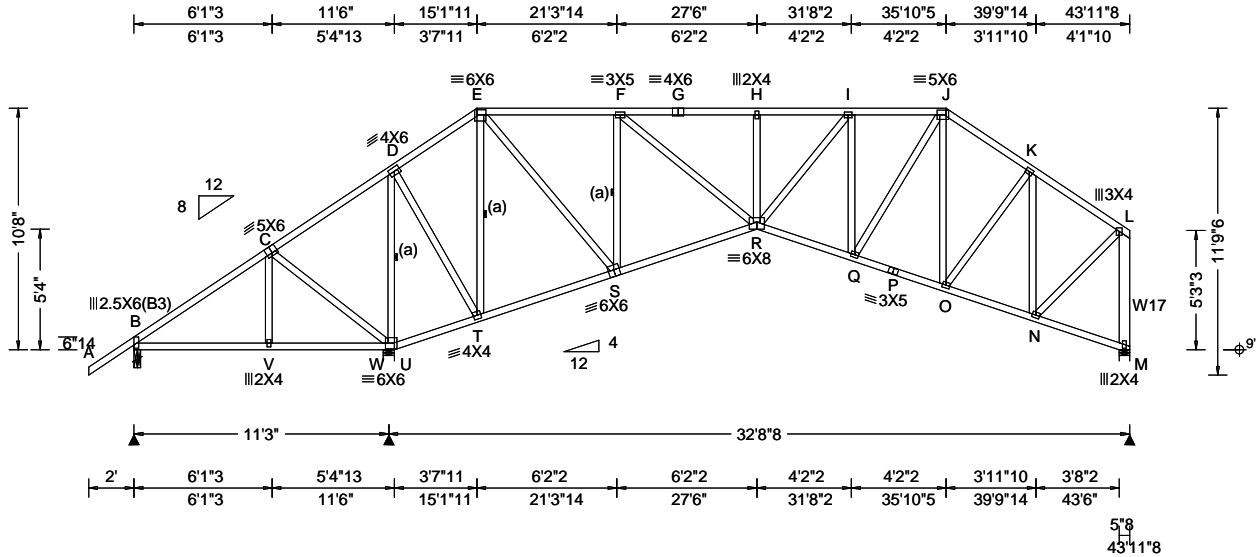

<b>Loading Criteria (psf)</b> TCCL: 20.00 TCDL: 10.00 BCLL: 0.00 BCDL: 10.00 Des Ld: 40.00 NCBCLL: 10.00 Soffit: 2.00 Load Duration: 1.25 Spacing: 24.0 "	<b>Wind Criteria</b> Wind Std: ASCE 7-22 Speed: 130 mph Enclosure: Enclosed Risk Category: II EXP: C Kzt: NA Mean Height: 17.41 ft TCDL: 5.0 psf BCDL: 5.0 psf MWFRS Parallel Dist: h to 2h C&C Dist a: 4.40 ft Loc. from endwall: not in 13.00 ft GCp: 0.18 Wind Duration: 1.60	<b>Snow Criteria (Pg,Pf in PSF)</b> Pg: NA Ct: NA CAT: NA Pf: NA Ce: NA Lu: NA Cs: NA Snow Duration: NA  Building Code: FBC 8th Ed. 2023 Res. TPI Std: 2014 Rep Fac: Yes FT/RT:20(0)/10(0) Plate Type(s): WAVE	<b>Defl/CSI Criteria</b> PP Deflection in loc L/defl L/# VERT(LL): 0.099 H 999 360 VERT(CL): 0.206 H 999 240 HORZ(LL): 0.075 M - - HORZ(TL): 0.154 M - - Creep Factor: 2.0 Max TC CSI: 0.536 Max BC CSI: 0.428 Max Web CSI: 0.660  VIEW Ver: 24.02.00D.0114.10	<b>▲ Maximum Reactions (lbs)</b> <table style="width:100%; border-collapse: collapse;"> <thead> <tr> <th rowspan="2">Loc</th> <th colspan="3">Gravity</th> <th colspan="3">Non-Gravity</th> </tr> <tr> <th>R+</th> <th>/R-</th> <th>/Rh</th> <th>/Rw</th> <th>/U</th> <th>/RL</th> </tr> </thead> <tbody> <tr> <td>B</td> <td>354</td> <td>-109</td> <td>-</td> <td>/68</td> <td>/34</td> <td>/485</td> </tr> <tr> <td>W</td> <td>2476</td> <td>-</td> <td>-</td> <td>/1581</td> <td>-</td> <td>-</td> </tr> <tr> <td>M</td> <td>1229</td> <td>-</td> <td>-</td> <td>/758</td> <td>-</td> <td>-</td> </tr> </tbody> </table> <p>Wind reactions based on MWFRS          B Brg Wid = 3.5 Min Req = 1.5 (Truss)          W Brg Wid = 6.0 Min Req = 2.9 (Truss)          M Brg Wid = 5.5 Min Req = 1.5 (Truss)</p> <p>Bearings B, W, &amp; M are a rigid surface.          Members not listed have forces less than 375#</p> <b>Maximum Top Chord Forces Per Ply (lbs)</b> <table style="width:100%; border-collapse: collapse;"> <thead> <tr> <th>Chords</th> <th>Tens.Comp.</th> <th>Chords</th> <th>Tens. Comp.</th> </tr> </thead> <tbody> <tr> <td>B - C</td> <td>519 -162</td> <td>H - I</td> <td>498 -1762</td> </tr> <tr> <td>C - D</td> <td>868 -138</td> <td>I - J</td> <td>406 -1354</td> </tr> <tr> <td>E - F</td> <td>352 -875</td> <td>J - K</td> <td>295 -1195</td> </tr> <tr> <td>F - G</td> <td>503 -1762</td> <td>K - L</td> <td>183 -900</td> </tr> <tr> <td>G - H</td> <td>503 -1762</td> <td></td> <td></td> </tr> </tbody> </table>	Loc	Gravity			Non-Gravity			R+	/R-	/Rh	/Rw	/U	/RL	B	354	-109	-	/68	/34	/485	W	2476	-	-	/1581	-	-	M	1229	-	-	/758	-	-	Chords	Tens.Comp.	Chords	Tens. Comp.	B - C	519 -162	H - I	498 -1762	C - D	868 -138	I - J	406 -1354	E - F	352 -875	J - K	295 -1195	F - G	503 -1762	K - L	183 -900	G - H	503 -1762		
Loc	Gravity			Non-Gravity																																																										
	R+	/R-	/Rh	/Rw	/U	/RL																																																								
B	354	-109	-	/68	/34	/485																																																								
W	2476	-	-	/1581	-	-																																																								
M	1229	-	-	/758	-	-																																																								
Chords	Tens.Comp.	Chords	Tens. Comp.																																																											
B - C	519 -162	H - I	498 -1762																																																											
C - D	868 -138	I - J	406 -1354																																																											
E - F	352 -875	J - K	295 -1195																																																											
F - G	503 -1762	K - L	183 -900																																																											
G - H	503 -1762																																																													

**Lumber**  
 Top chord: 2x4 SP #2;  
 Bot chord: 2x4 SP #2;  
 Webs: 2x4 SP #3; W17 2x6 SP #2;

**Bracing**  
 (a) Continuous lateral restraint equally spaced on member.

**Plating Notes**  
 All plates are 3X4 except as noted.

**Loading**  
 Truss passed check for 20 psf additional bottom chord live load in areas with 42"-high x 24"-wide clearance.

**Wind**  
 Wind loads based on MWFRS with additional C&C member design.  
 Right end vertical not exposed to wind pressure.  
 Wind loading based on both gable and hip roof types.

**Additional Notes**  
 Shim all supports to solid bearing.  
 The overall height of this truss excluding overhang is 10-8-0.

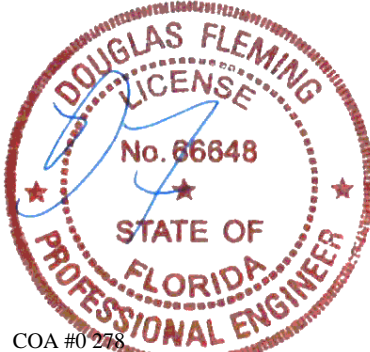

COA #0 278  
 Florida Certificate of Product Approval #FL1999  
 02/25/2026

**\*\*WARNING\*\* READ AND FOLLOW ALL NOTES ON THIS DRAWING!**  
**\*\*IMPORTANT\*\* FURNISH THIS DRAWING TO ALL CONTRACTORS INCLUDING THE INSTALLERS**  
 Trusses require extreme care in fabricating, handling, shipping, installing and bracing. Refer to and follow the latest edition of BCSI (Building Component Safety Information, by TPI and SBCA) for safety practices prior to performing these functions. Installers shall provide temporary bracing per BCSI. Unless noted otherwise, top chord shall have properly attached structural sheathing and bottom chord shall have a properly attached rigid ceiling. Locations shown for permanent lateral restraint of webs shall have continuous lateral restraint (CLR), installed with diagonal bracing installed on the CLR per BCSI sections B3, B7, or B10, as applicable. Apply plates to each face of truss and position as shown above and on the Joint Details, unless noted otherwise. Refer to drawings 160A-Z for standard plate positions. Refer to job's General Notes page for additional information.  
 Alpine, a division of ITW Building Components Group Inc. shall not be responsible for any deviation from this drawing, any failure to build the truss in conformance with ANSI/TPI 1, or for handling, shipping, installation and bracing of trusses. A seal on this drawing or cover page listing this drawing, indicates acceptance of professional engineering responsibility solely for the design shown. The suitability and use of this drawing for any structure is the responsibility of the Building Designer per ANSI/TPI 1 Sec.2.  
 For more information see these web sites: Alpine: alpineitw.com; TPI: tpinst.org; SBCA: sbcacomponents.com; ICC: iccsafe.org; AWC: awc.org



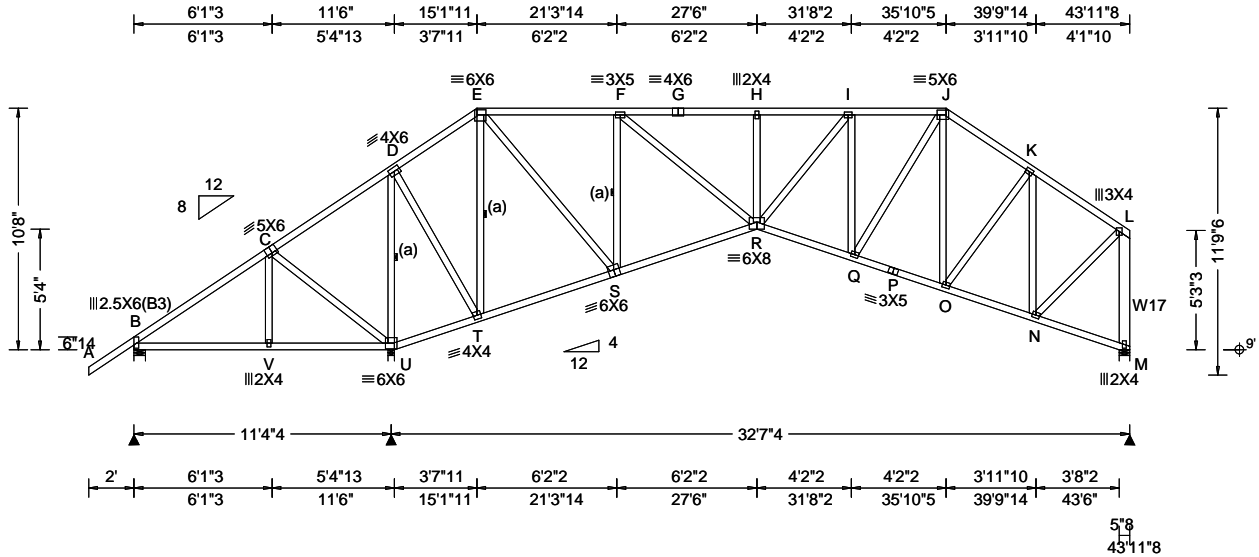

<b>Loading Criteria (psf)</b> TCCL: 20.00 TCCL: 10.00 BCLL: 0.00 BCDL: 10.00 Des Ld: 40.00 NCBCLL: 10.00 Soffit: 2.00 Load Duration: 1.25 Spacing: 24.0 "	<b>Wind Criteria</b> Wind Std: ASCE 7-22 Speed: 130 mph Enclosure: Enclosed Risk Category: II EXP: C Kzt: NA Mean Height: 17.41 ft TCCL: 5.0 psf BCDL: 5.0 psf MWFRS Parallel Dist: h to 2h C&C Dist a: 4.40 ft Loc. from endwall: not in 13.00 ft GCp: 0.18 Wind Duration: 1.60	<b>Snow Criteria (Pg,Pf in PSF)</b> Pg: NA Ct: NA CAT: NA Pf: NA Ce: NA Lu: NA Cs: NA Snow Duration: NA Building Code: FBC 8th Ed. 2023 Res. TPI Std: 2014 Rep Fac: Yes FT/RT:20(0)/10(0) Plate Type(s): WAVE	<b>Defl/CSI Criteria</b> PP Deflection in loc L/defl L/# VERT(LL): 0.099 H 999 360 VERT(CL): 0.206 H 999 240 HORZ(LL): 0.075 M - - HORZ(TL): 0.154 M - - Creep Factor: 2.0 Max TC CSI: 0.536 Max BC CSI: 0.428 Max Web CSI: 0.660 VIEW Ver: 24.02.00D.0114.10	<b>▲ Maximum Reactions (lbs)</b> <table style="width:100%; border-collapse: collapse;"> <thead> <tr> <th rowspan="2">Loc</th> <th colspan="3">Gravity</th> <th colspan="3">Non-Gravity</th> </tr> <tr> <th>R+</th> <th>/R-</th> <th>/Rh</th> <th>/Rw</th> <th>/U</th> <th>/RL</th> </tr> </thead> <tbody> <tr> <td>B</td> <td>354</td> <td>-110</td> <td>-</td> <td>/68</td> <td>/34</td> <td>/485</td> </tr> <tr> <td>U</td> <td>2476</td> <td>-</td> <td>-</td> <td>/1581</td> <td>-</td> <td>-</td> </tr> <tr> <td>M</td> <td>1229</td> <td>-</td> <td>-</td> <td>/758</td> <td>-</td> <td>-</td> </tr> </tbody> </table> <p>Wind reactions based on MWFRS          B Brg Wid = 6.0 Min Req = 1.5 (Truss)          U Brg Wid = 3.5 Min Req = 2.9 (Truss)          M Brg Wid = 5.5 Min Req = 1.5 (Truss)</p> <p>Bearings B, U, &amp; M are a rigid surface.          Members not listed have forces less than 375#</p> <b>Maximum Top Chord Forces Per Ply (lbs)</b> <table style="width:100%; border-collapse: collapse;"> <thead> <tr> <th>Chords</th> <th>Tens.Comp.</th> <th>Chords</th> <th>Tens. Comp.</th> </tr> </thead> <tbody> <tr> <td>B - C</td> <td>519 -162</td> <td>H - I</td> <td>498 -1762</td> </tr> <tr> <td>C - D</td> <td>868 -138</td> <td>I - J</td> <td>406 -1354</td> </tr> <tr> <td>E - F</td> <td>352 -875</td> <td>J - K</td> <td>295 -1195</td> </tr> <tr> <td>F - G</td> <td>503 -1762</td> <td>K - L</td> <td>183 -900</td> </tr> <tr> <td>G - H</td> <td>503 -1762</td> <td></td> <td></td> </tr> </tbody> </table>	Loc	Gravity			Non-Gravity			R+	/R-	/Rh	/Rw	/U	/RL	B	354	-110	-	/68	/34	/485	U	2476	-	-	/1581	-	-	M	1229	-	-	/758	-	-	Chords	Tens.Comp.	Chords	Tens. Comp.	B - C	519 -162	H - I	498 -1762	C - D	868 -138	I - J	406 -1354	E - F	352 -875	J - K	295 -1195	F - G	503 -1762	K - L	183 -900	G - H	503 -1762		
Loc	Gravity			Non-Gravity																																																										
	R+	/R-	/Rh	/Rw	/U	/RL																																																								
B	354	-110	-	/68	/34	/485																																																								
U	2476	-	-	/1581	-	-																																																								
M	1229	-	-	/758	-	-																																																								
Chords	Tens.Comp.	Chords	Tens. Comp.																																																											
B - C	519 -162	H - I	498 -1762																																																											
C - D	868 -138	I - J	406 -1354																																																											
E - F	352 -875	J - K	295 -1195																																																											
F - G	503 -1762	K - L	183 -900																																																											
G - H	503 -1762																																																													

**Lumber**  
 Top chord: 2x4 SP #2;  
 Bot chord: 2x4 SP #2;  
 Webs: 2x4 SP #3; W17 2x6 SP #2;

**Bracing**  
 (a) Continuous lateral restraint equally spaced on member.

**Plating Notes**  
 All plates are 3X4 except as noted.

**Loading**  
 Truss passed check for 20 psf additional bottom chord live load in areas with 42"-high x 24"-wide clearance.

**Wind**  
 Wind loads based on MWFRS with additional C&C member design.  
 Right end vertical not exposed to wind pressure.  
 Wind loading based on both gable and hip roof types.

**Additional Notes**  
 Shim all supports to solid bearing.  
 The overall height of this truss excluding overhang is 10-8-0.

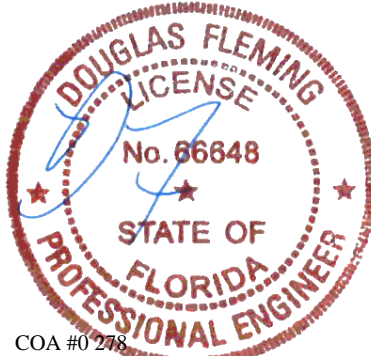

COA #0278  
 Florida Certificate of Product Approval #FL1999  
 02/25/2026

**\*\*WARNING\*\* READ AND FOLLOW ALL NOTES ON THIS DRAWING!**  
**\*\*IMPORTANT\*\* FURNISH THIS DRAWING TO ALL CONTRACTORS INCLUDING THE INSTALLERS**  
 Trusses require extreme care in fabricating, handling, shipping, installing and bracing. Refer to and follow the latest edition of BCSI (Building Component Safety Information, by TPI and SBCA) for safety practices prior to performing these functions. Installers shall provide temporary bracing per BCSI. Unless noted otherwise, top chord shall have properly attached structural sheathing and bottom chord shall have a properly attached rigid ceiling. Locations shown for permanent lateral restraint of webs shall have continuous lateral restraint (CLR), installed with diagonal bracing installed on the CLR per BCSI sections B3, B7, or B10, as applicable. Apply plates to each face of truss and position as shown above and on the Joint Details, unless noted otherwise. Refer to drawings 160A-Z for standard plate positions. Refer to job's General Notes page for additional information.  
 Alpine, a division of ITW Building Components Group Inc. shall not be responsible for any deviation from this drawing, any failure to build the truss in conformance with ANSI/TPI 1, or for handling, shipping, installation and bracing of trusses. A seal on this drawing or cover page listing this drawing, indicates acceptance of professional engineering responsibility solely for the design shown. The suitability and use of this drawing for any structure is the responsibility of the Building Designer per ANSI/TPI 1 Sec.2.  
 For more information see these web sites: Alpine: alpineitw.com; TPI: tpinst.org; SBCA: sbccomponents.com; ICC: iccsafe.org; AWC: awc.org



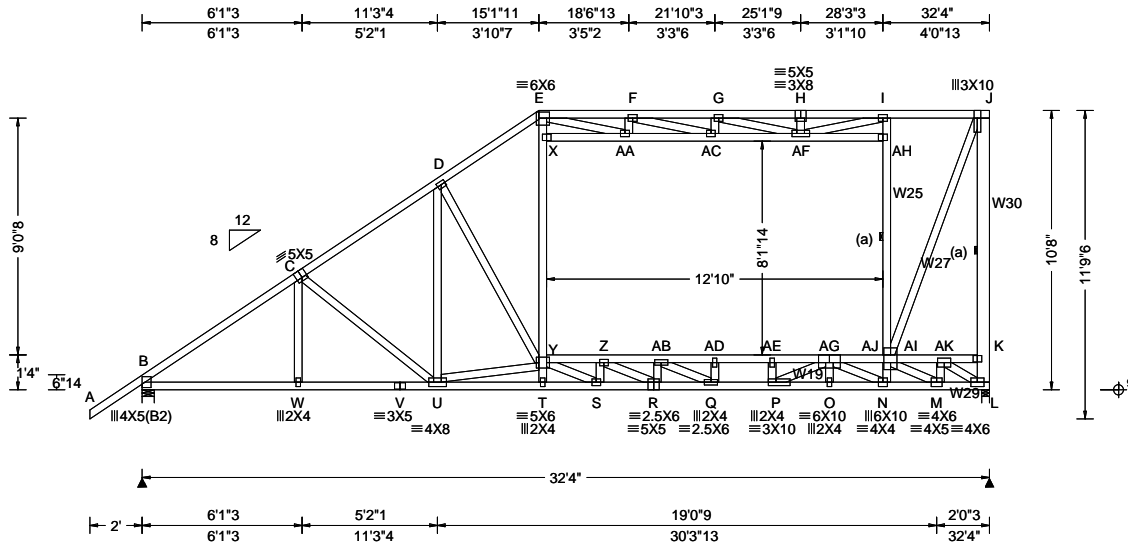

<b>Loading Criteria (psf)</b> TCLL: 20.00 TCDL: 10.00 BCLL: 0.00 BCDL: 10.00 Des Ld: 40.00 NCBCLL: 10.00 Soffit: 2.00 Load Duration: 1.25 Spacing: 16.0 "	<b>Wind Criteria</b> Wind Std: ASCE 7-22 Speed: 130 mph Enclosure: Enclosed Risk Category: II EXP: C Kzt: NA Mean Height: 17.41 ft TCDL: 5.0 psf BCDL: 5.0 psf MWFRS Parallel Dist: 0 to h/2 C&C Dist a: 3.23 ft Loc. from endwall: Any GCp: 0.18 Wind Duration: 1.60	<b>Snow Criteria (Pg,Pf in PSF)</b> Pg: NA Ct: NA CAT: NA Pf: NA Ce: NA Lu: NA Cs: NA Snow Duration: NA  Building Code: FBC 8th Ed. 2023 Res. TPI Std: 2014 Rep Fac: Yes FT/RT:20(0)/10(0) Plate Type(s): WAVE	<b>Defl/CSI Criteria</b> PP Deflection in loc L/defl L/# VERT(LL): 0.272 T 999 360 VERT(CL): 0.540 T 717 240 HORZ(LL): 0.163 AF - - HORZ(TL): 0.327 AF - - Creep Factor: 2.0 Max TC CSI: 0.464 Max BC CSI: 0.426 Max Web CSI: 0.834  VIEW Ver: 24.02.00D.0114.10	<b>▲ Maximum Reactions (lbs)</b> Gravity Loc R+ / R- / Rh / Rw / U / RL B 1406 - / - / - / 643 / 88 / 327 L 1741 - / - / - / 735 / 87 / - Wind reactions based on MWFRS B Brg Wid = 5.5 Min Req = 1.5 (Truss) L Brg Wid = 3.5 Min Req = 1.5 (Truss) Bearings B & L are a rigid surface. Members not listed have forces less than 375# <b>Maximum Top Chord Forces Per Ply (lbs)</b> Chords Tens.Comp. Chords Tens. Comp. B - C 156 -1992 F - G 571 -2250 C - D 170 -1797 G - H 458 -1663 D - E 99 -1416 H - I 458 -1663 E - F 448 -2073 I - J 213 -1068
--	--	--	---	--

**Lumber**  
Top chord: 2x4 SP M-31;  
Bot chord: 2x4 SP M-31;  
Webs: 2x4 SP #3; W19, W27, W29 2x4 SP #2;  
W25 2x4 SP M-31; W30 2x6 SP 2400f-2.0E;

**Bracing**  
(a) Continuous lateral restraint equally spaced on member.

**Plating Notes**  
All plates are 3X4 except as noted.

**Loading**  
Attic room loading from 15-5-3 to 28-3-3: Live Load: 40 PSF. Dead Load: 10 PSF Ceiling: 10 PSF, Kneewalls: 10 PSF

**Purlins**  
Collar-tie braced with continuous lateral bracing at 24" oc. or rigid ceiling.

**Wind**  
Wind loads based on MWFRS with additional C&C member design.  
Right end vertical not exposed to wind pressure.  
Wind loading based on both gable and hip roof types.

**Additional Notes**  
The overall height of this truss excluding overhang is 10-8-0.



COA #0218  
Florida Certificate of Product Approval #FL199AD-AE  
02/25/2026

**Maximum Bot Chord Forces Per Ply (lbs)**

Chords	Tens.Comp.	Chords	Tens. Comp.
B - W	1577 -423	R - Q	2208 -89
W - V	1577 -424	Q - P	960 0
V - U	1577 -424	P - O	549 -1502
U - T	2873 -869	O - N	549 -1502
T - S	2968 -897	N - M	609 -3330
S - R	2647 -411	M - L	317 -1647

**Maximum Web Forces Per Ply (lbs)**

Webs	Tens.Comp.	Webs	Tens. Comp.
U - D	551 -194	G - AF	176 -628
U - Y	565 -1492	AE - P	92 -667
D - Y	309 -666	AE-AG	416 -444
E - X	448 0	P - AG	2445 -295
E - AA	864 -266	AF - I	801 -256
X - Y	425 0	AG - N	63 -1724
Y - S	474 -396	AG-AI	4108 -762
Y - Z	306 -1634	I - AH	179 -532
Z - R	319 -404	N - AI	1086 -16
Z - AB	0 -1222	AH-AI	184 -566
AA-AC	1029 -316	AI - M	1678 -283
R - AB	403 -158	AI-AK	1900 -368
AB - Q	400 -1554	AJ - J	2814 -386
AB-AD	341 -418	M - AK	182 -890
Q - AD	386 -93	AK - L	1775 -347
AC-AF	1140 -364	K - J	370 -2630
AD-AE	378 -431	K - L	368 -2625

**\*\*WARNING\*\* READ AND FOLLOW ALL NOTES ON THIS DRAWING!**  
**\*\*IMPORTANT\*\* FURNISH THIS DRAWING TO ALL CONTRACTORS INCLUDING THE INSTALLERS**  
Trusses require extreme care in fabricating, handling, shipping, installing and bracing. Refer to and follow the latest edition of BCSI (Building Component Safety Information, by TPI and SBCA) for safety practices prior to performing these functions. Installers shall provide temporary bracing per BCSI. Unless noted otherwise, top chord shall have properly attached structural sheathing and bottom chord shall have a properly attached rigid ceiling. Locations shown for permanent lateral restraint of webs shall have continuous lateral restraint (CLR), installed with diagonal bracing installed on the CLR per BCSI sections B3, B7, or B10, as applicable. Apply plates to each face of truss and position as shown above and on the Joint Details, unless noted otherwise. Refer to drawings 160A-Z for standard plate positions. Refer to job's General Notes page for additional information.  
Alpine, a division of ITW Building Components Group Inc. shall not be responsible for any deviation from this drawing, any failure to build the truss in conformance with ANSI/TPI 1, or for handling, shipping, installation and bracing of trusses. A seal on this drawing or cover page listing this drawing, indicates acceptance of professional engineering responsibility solely for the design shown. The suitability and use of this drawing for any structure is the responsibility of the Building Designer per ANSI/TPI 1 Sec.2.  
For more information see these web sites: Alpine: alpineitw.com; TPI: tpinst.org; SBCA: sbccomponents.com; ICC: iccsafe.org; AWC: awc.org



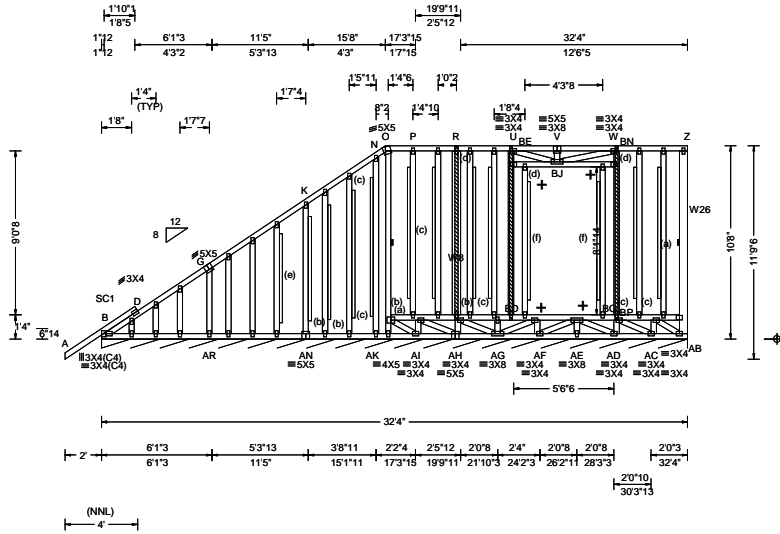

<b>Loading Criteria (psf)</b> TCCL: 20.00 TCCL: 10.00 BCLL: 0.00 BCDL: 10.00 Des Ld: 40.00 NCBCLL: 10.00 Soffit: 2.00 Load Duration: 1.25 Spacing: 24.0 "	<b>Wind Criteria</b> Wind Std: ASCE 7-22 Speed: 130 mph Enclosure: Enclosed Risk Category: II EXP: C Kzt: NA Mean Height: 17.41 ft TCCL: 5.0 psf BCDL: 5.0 psf MWFRS Parallel Dist: 0 to h/2 C&C Dist a: 3.23 ft Loc. from endwall: Any GCp: 0.18 Wind Duration: 1.60	<b>Snow Criteria (Pg,Pf in PSF)</b> Pg: NA Ct: NA CAT: NA Pf: NA Ce: NA Lu: NA Cs: NA Snow Duration: NA Building Code: FBC 8th Ed. 2023 Res. TPI Std: 2014 Rep Fac: Varies by Ld Case FT/RT:20(0)/10(0) Plate Type(s): WAVE	<b>Defl/CSI Criteria</b> PP Deflection in loc L/defl L/# VERT(LL): 0.022 V 999 360 VERT(CL): 0.036 V 999 240 HORZ(LL): -0.003 W - - HORZ(TL): 0.014 Z - - Creep Factor: 2.0 Max TC CSI: 0.523 Max BC CSI: 0.196 Max Web CSI: 0.990 VIEW Ver: 24.02.00D.0114.10	<b>▲ Maximum Reactions (lbs), or *=PLF</b> <table border="1"> <thead> <tr> <th rowspan="2">Loc</th> <th colspan="3">Gravity</th> <th colspan="3">Non-Gravity</th> </tr> <tr> <th>R+</th> <th>/R-</th> <th>/Rh</th> <th>/Rw</th> <th>/U</th> <th>/RL</th> </tr> </thead> <tbody> <tr> <td>AB* 165</td> <td>-</td> <td>-</td> <td>-</td> <td>/72</td> <td>/3</td> <td>/13</td> </tr> </tbody> </table> Wind reactions based on MWFRS AB Brg Wid = 388 Min Req = - Bearing B is a rigid surface. Members not listed have forces less than 375# <b>Maximum Top Chord Forces Per Ply (lbs)</b> <table border="1"> <thead> <tr> <th rowspan="2">Chords</th> <th colspan="2">Tens.Comp.</th> <th rowspan="2">Chords</th> <th colspan="2">Tens. Comp.</th> </tr> <tr> <th></th> <th></th> <th></th> <th></th> </tr> </thead> <tbody> <tr> <td>B - D</td> <td>234</td> <td>-439</td> <td>G - K</td> <td>237</td> <td>-461</td> </tr> <tr> <td>B - D</td> <td>379</td> <td>-460</td> <td>U - V</td> <td>334</td> <td>-570</td> </tr> <tr> <td>D - G</td> <td>308</td> <td>-648</td> <td>V - W</td> <td>334</td> <td>-570</td> </tr> </tbody> </table>	Loc	Gravity			Non-Gravity			R+	/R-	/Rh	/Rw	/U	/RL	AB* 165	-	-	-	/72	/3	/13	Chords	Tens.Comp.		Chords	Tens. Comp.						B - D	234	-439	G - K	237	-461	B - D	379	-460	U - V	334	-570	D - G	308	-648	V - W	334	-570
Loc	Gravity			Non-Gravity																																																
	R+	/R-	/Rh	/Rw	/U	/RL																																														
AB* 165	-	-	-	/72	/3	/13																																														
Chords	Tens.Comp.		Chords	Tens. Comp.																																																
B - D	234	-439	G - K	237	-461																																															
B - D	379	-460	U - V	334	-570																																															
D - G	308	-648	V - W	334	-570																																															

**Lumber**  
 Top chord: 2x4 SP #2;  
 Bot chord: 2x4 SP #2;  
 Webs: 2x4 SP #3; W8 2x6 SP 2400f-2.0E;  
 W26 2x6 SP #2;  
 Stack Chord: SC1 2x4 SP #2;

**Bracing**  
 (a) Continuous lateral restraint equally spaced on member.

**Plating Notes**  
 All plates are 2X4 except as noted.

**Loading**  
 Truss designed to support 1-4-0 top chord outlookers and cladding load not to exceed 5.00 PSF one face and 24.0" span opposite face. Top chord must not be cut or notched, unless specified otherwise.  
 Attic room loading from 22-8-13 to 28-3-3: Live Load: 40 PSF. Dead Load: 10 PSF Ceiling: 10 PSF, Kneewalls: 10 PSF

**Purlins**  
 In lieu of structural panels use purlins to brace all sloping TC @ 24" oc; all flat TC @ 0" oc.  
 Collar-tie braced with continuous lateral bracing at 24" oc. or rigid ceiling.  
 + MEMBER TO BE LATERALLY BRACED FOR HORIZONTAL WIND LOADS.

**Wind**  
 Wind loads based on MWFRS with additional C&C member design.  
 Right end vertical not exposed to wind pressure.  
 Wind loading based on both gable and hip roof types.  
 Gable meets L/120 deflection criteria for wind load applied to face. Calculated deflection ratio is L/201.

**Maximum Bot Chord Forces Per Ply (lbs)**

Chords	Tens.Comp.		Chords	Tens. Comp.	
B-AR	759	-247	AR-AN	766	-251

**Maximum Web Forces Per Ply (lbs)**

Webs	Tens.Comp.		Webs	Tens. Comp.	
BD-AG	125	-600	BJ- W	585	-116
BE- U	93	-455	W -BN	134	-630
U -BJ	602	-115	AD-BP	140	-660
V -BJ	109	-516	BN-BO	115	-545

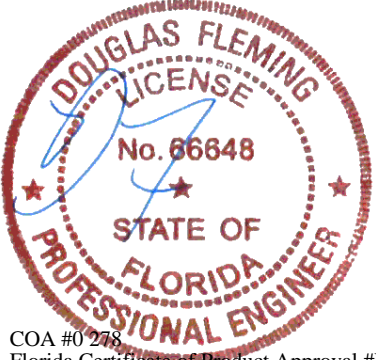

COA #0 278  
 Florida Certificate of Product Approval #FL1999  
 02/25/2026

**\*\*WARNING\*\* READ AND FOLLOW ALL NOTES ON THIS DRAWING!**  
**\*\*IMPORTANT\*\* FURNISH THIS DRAWING TO ALL CONTRACTORS INCLUDING THE INSTALLERS**  
 Trusses require extreme care in fabricating, handling, shipping, installing and bracing. Refer to and follow the latest edition of BCSI (Building Component Safety Information, by TPI and SBCA) for safety practices prior to performing these functions. Installers shall provide temporary bracing per BCSI. Unless noted otherwise, top chord shall have properly attached structural sheathing and bottom chord shall have a properly attached rigid ceiling. Locations shown for permanent lateral restraint of webs shall have continuous lateral restraint (CLR), installed with diagonal bracing installed on the CLR per BCSI sections B3, B7, or B10, as applicable. Apply plates to each face of truss and position as shown above and on the Joint Details, unless noted otherwise. Refer to drawings 160A-Z for standard plate positions. Refer to job's General Notes page for additional information.  
 Alpine, a division of ITW Building Components Group Inc. shall not be responsible for any deviation from this drawing, any failure to build the truss in conformance with ANSI/TPI 1, or for handling, shipping, installation and bracing of trusses. A seal on this drawing or cover page listing this drawing, indicates acceptance of professional engineering responsibility solely for the design shown. The suitability and use of this drawing for any structure is the responsibility of the Building Designer per ANSI/TPI 1 Sec.2.  
 For more information see these web sites: Alpine: alpineitw.com; TPI: tpinst.org; SBCA: sbcacomponents.com; ICC: iccsafe.org; AWC: awc.org



SEQN: 728240	GABL	Ply: 1	Job Number: 26-3388d	Cust: R 215 JRef: 1YHX2150002 T19
FROM: RFG		Qty: 1	JOHNSON	DrwNo: 056.26.0828.24630
Page 2 of 2			Truss Label: B1E	JB / DF 02/25/2026

**Gable Reinforcement**

- (b) 2x4 "L" reinforcement. Same species and grade as web. 80% length of web member. Attach with 10d (0.131"x3",min.) nails @ 2" oc at each end for the first 18" and then 4" oc for the remainder.
- (c) 2x6 "L" reinforcement. Any species and grade. 80% length of web member. Attach with 10d (0.131"x3",min.) nails @ 2" oc at each end for the first 18" and then 4" oc for the remainder.
- (d) 2x3 "T" reinforcement. Any species and grade. Full truss height along web member. Attach to the wide face with 10d (0.131"x3",min.) nails @ 4" oc in the web plus (2)10d (0.131"x3",min.) nails in each chord.
- (e) 2x4 "L" reinforcement. Any species and grade. 80% length of web member. Attach with 10d (0.131"x3",min.) nails @ 2" oc at each end for the first 18" and then 4" oc for the remainder.
- (f) 2x6 "L" reinforcement. Same species and grade as web. 80% length of web member. Attach with 10d (0.131"x3",min.) nails @ 2" oc at each end for the first 18" and then 4" oc for the remainder.

**Additional Notes**

Exposed portion of gable face shall be reinforced with sheathing and the wind pressures shall be transferred into lateral diaphragms. Connections and designs for diaphragms is the responsibility of the Building Designer in accordance with ANSI/TPI 1.

Stacked top chord must NOT be notched or cut in area (NNL). Dropped top chord braced at 24" oc intervals. Attach stacked top chord (SC) to dropped top chord in notchable area using 3x4 tie-plates 24" oc. Center plate on stacked/dropped chord interface, plate length perpendicular to chord length. Splice top chord in notchable area using 3x6.

The overall height of this truss excluding overhang is 10-8-0.

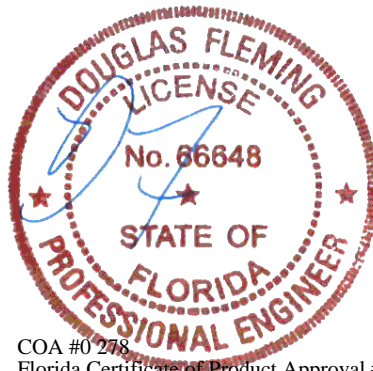

COA #0 278  
 Florida Certificate of Product Approval #FL1999  
 02/25/2026

**\*\*WARNING\*\* READ AND FOLLOW ALL NOTES ON THIS DRAWING!**  
**\*\*IMPORTANT\*\* FURNISH THIS DRAWING TO ALL CONTRACTORS INCLUDING THE INSTALLERS**  
 Trusses require extreme care in fabricating, handling, shipping, installing and bracing. Refer to and follow the latest edition of BCSI (Building Component Safety Information, by TPI and SBCA) for safety practices prior to performing these functions. Installers shall provide temporary bracing per BCSI. Unless noted otherwise, top chord shall have properly attached structural sheathing and bottom chord shall have a properly attached rigid ceiling. Locations shown for permanent lateral restraint of webs shall have continuous lateral restraint (CLR), installed with diagonal bracing installed on the CLR per BCSI sections B3, B7, or B10, as applicable. Apply plates to each face of truss and position as shown above and on the Joint Details, unless noted otherwise. Refer to drawings 160A-Z for standard plate positions. Refer to job's General Notes page for additional information.  
 Alpine, a division of ITW Building Components Group Inc. shall not be responsible for any deviation from this drawing, any failure to build the truss in conformance with ANSI/TPI 1, or for handling, shipping, installation and bracing of trusses. A seal on this drawing or cover page listing this drawing, indicates acceptance of professional engineering responsibility solely for the design shown. The suitability and use of this drawing for any structure is the responsibility of the Building Designer per ANSI/TPI 1 Sec.2.  
 For more information see these web sites: Alpine: [alpineitw.com](http://alpineitw.com); TPI: [tpinst.org](http://tpinst.org); SBCA: [sbcacomponents.com](http://sbcacomponents.com); ICC: [iccsafe.org](http://iccsafe.org); AWC: [awc.org](http://awc.org)



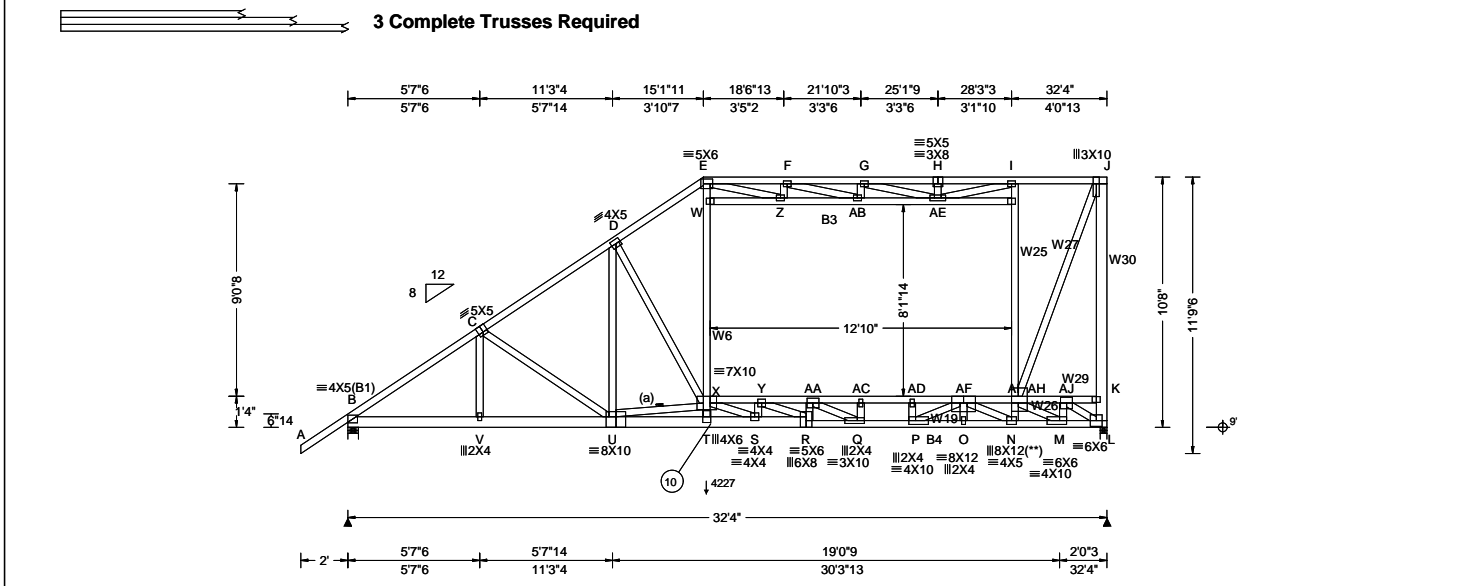

<b>Loading Criteria (psf)</b> TCLL: 20.00 TCDL: 10.00 BCLL: 0.00 BCDL: 10.00 Des Ld: 40.00 NCBCLL: 0.00 Soffit: 2.00 Load Duration: 1.00 Spacing: 16.0 "	<b>Wind Criteria</b> Wind Std: ASCE 7-22 Speed: 130 mph Enclosure: Enclosed Risk Category: II EXP: C Kzt: NA Mean Height: 17.41 ft TCDL: 5.0 psf BCDL: 5.0 psf MWFRS Parallel Dist: 0 to h/2 C&C Dist a: 3.23 ft Loc. from endwall: Any GCp: 0.18 Wind Duration: 1.60	<b>Snow Criteria (Pg,Pf in PSF)</b> Pg: NA Ct: NA CAT: NA Pf: NA Ce: NA Lu: NA Cs: NA Snow Duration: NA  Building Code: FBC 8th Ed. 2023 Res. TPI Std: 2014 Rep Fac: Yes FT/RT:20(0)/10(0) Plate Type(s): WAVE	<b>Defl/CSI Criteria</b> PP Deflection in loc L/defl L/# VERT(LL): 0.352 T 999 360 VERT(CL): 0.702 T 550 240 HORZ(LL): 0.227 AE - - HORZ(TL): 0.454 AE - - Creep Factor: 2.0 Max TC CSI: 0.751 Max BC CSI: 0.724 Max Web CSI: 0.893  VIEW Ver: 24.02.00D.0114.10	<b>▲ Maximum Reactions (lbs)</b> Gravity Non-Gravity Loc R+ / R- / Rh / Rw / U / RL B 3652 - / - / - / - /204 - / - L 3723 - / - / - / - /166 - / - Wind reactions based on MWFRS B Brg Wid = 5.5 Min Req = 1.5 (Truss) L Brg Wid = 3.5 Min Req = 1.5 (Truss) Bearings B & L are a rigid surface. Members not listed have forces less than 375# <b>Maximum Top Chord Forces Per Ply (lbs)</b> Chords Tens.Comp. Chords Tens. Comp. B - C 83 -1882 F - G 150 -1450 C - D 73 -1919 G - H 105 -1016 D - E 46 -1411 H - I 105 -1016 E - F 123 -1575 I - J 29 -1070
---	--	--	---	---

**Lumber**  
Top chord: 2x4 SP M-31;  
Bot chord: 2x6 SP 2400f-2.0E; B3,B4 2x4 SP M-31;  
Webs: 2x4 SP #3; W6,W19,W26,W27,W29 2x4 SP #2;  
W25 2x4 SP M-31; W30 2x6 SP 2400f-2.0E;

**Nailnote**  
Nail Schedule: 0.128"x3", min. nails  
Top Chord: 1 Row @ 12.00" o.c.  
Bot Chord: 1 Row @ 8.25" o.c.  
Webs : 1 Row @ 4" o.c.  
Repeat nailing as each layer is applied. Use equal spacing between rows and stagger nails in each row to avoid splitting.

**Plating Notes**  
All plates are 3X4 except as noted.  
(\*\*) 1 plate(s) require special positioning. Refer to scaled plate plot details for special positioning requirements.

**Loading**  
Attic room loading from 15-5-3 to 28-3-3: Live Load: 40 PSF. Dead Load: 10 PSF Ceiling: 10 PSF, Kneewalls: 10 PSF

**Purlins**  
Collar-tie braced with continuous lateral bracing at 24" oc. or rigid ceiling.

**Additional Notes**  
The overall height of this truss excluding overhang is 10-8-0.

**Wind**  
Wind loads and reactions based on MWFRS.  
Right end vertical not exposed to wind pressure.  
Wind loading based on both gable and hip roof types.

**Special loads**  
----- (Lumber Dur.Fac.=1.00 / Plate Dur.Fac.=1.00)  
TC: From 43 plf at -2.00 to 43 plf at 32.33  
PLT: From 13 plf at 15.43 to 13 plf at 28.27  
PLT: From 67 plf at 15.43 to 67 plf at 28.27  
BC: From 3 plf at -2.00 to 3 plf at 0.00  
BC: From 13 plf at 0.00 to 13 plf at 32.33  
BC: 4227 lb Conc. Load at 15.27  
BC: 109 lb Conc. Load at 15.43,28.27

Evenly distribute additional (0.128"x3.0" min\_nails) in third ply of (3) Ply truss opposite from hanger connection as shown by nail circles without splitting lumber.

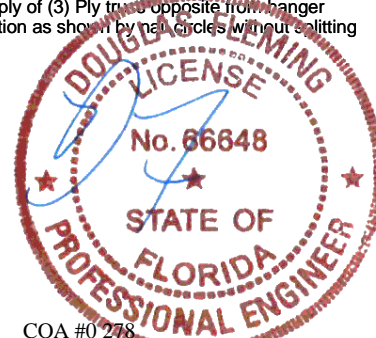

COA #0278  
Florida Certificate of Product Approval #FL1999  
02/25/2026

**Maximum Bot Chord Forces Per Ply (lbs)**

Chords	Tens.Comp.	Chords	Tens. Comp.
B - V	1536 -62	R - Q	2123 -27
V - U	1537 -62	P - O	61 -2987
U - T	4952 -139	O - N	61 -2987
T - S	5166 -143	N - M	66 -4700
S - R	3598 -77	M - L	36 -2292

**Maximum Web Forces Per Ply (lbs)**

Webs	Tens.Comp.	Webs	Tens. Comp.
U - D	936 -20	AC-AD	1349 -57
U - X	88 -3444	G - AE	49 -430
D - X	41 -892	AD - P	12 -765
E - W	747 0	AD-AF	1455 -59
W - X	730 0	P - AF	2959 -38
X - T	950 -22	AF - N	5 -1630
X - S	62 -1414	AF-AH	5543 -97
X - Y	54 -2755	N - AH	966 0
S - Y	867 -29	AH - M	2395 -28
Y - R	50 -1379	AH-AJ	2653 -42
Y - AA	2 -1275	AI - J	2817 -76
Z - AB	487 -99	M - AJ	20 -1288
R - AA	930 -23	AJ - L	2513 -38
AA - Q	58 -2590	K - J	78 -2574
AA - AC	1255 -64	K - L	77 -2563
Q - AC	677 -12		

**\*\*WARNING\*\* READ AND FOLLOW ALL NOTES ON THIS DRAWING!**  
**\*\*IMPORTANT\*\* FURNISH THIS DRAWING TO ALL CONTRACTORS INCLUDING THE INSTALLERS**  
Trusses require extreme care in fabricating, handling, shipping, installing and bracing. Refer to and follow the latest edition of BCSI (Building Component Safety Information, by TPI and SBCA) for safety practices prior to performing these functions. Installers shall provide temporary bracing per BCSI. Unless noted otherwise, top chord shall have properly attached structural sheathing and bottom chord shall have a properly attached rigid ceiling. Locations shown for permanent lateral restraint of webs shall have continuous lateral restraint (CLR), installed with diagonal bracing installed on the CLR per BCSI sections B3, B7, or B10, as applicable. Apply plates to each face of truss and position as shown above and on the Joint Details, unless noted otherwise. Refer to drawings 160A-Z for standard plate positions. Refer to job's General Notes page for additional information.  
Alpine, a division of ITW Building Components Group Inc. shall not be responsible for any deviation from this drawing, any failure to build the truss in conformance with ANSI/TPI 1, or for handling, shipping, installation and bracing of trusses. A seal on this drawing or cover page listing this drawing, indicates acceptance of professional engineering responsibility solely for the design shown. The suitability and use of this drawing for any structure is the responsibility of the Building Designer per ANSI/TPI 1 Sec.2.  
For more information see these web sites: Alpine: alpineitw.com; TPI: tpinst.org; SBCA: sbcacomponents.com; ICC: iccsafe.org; AWC: awc.org



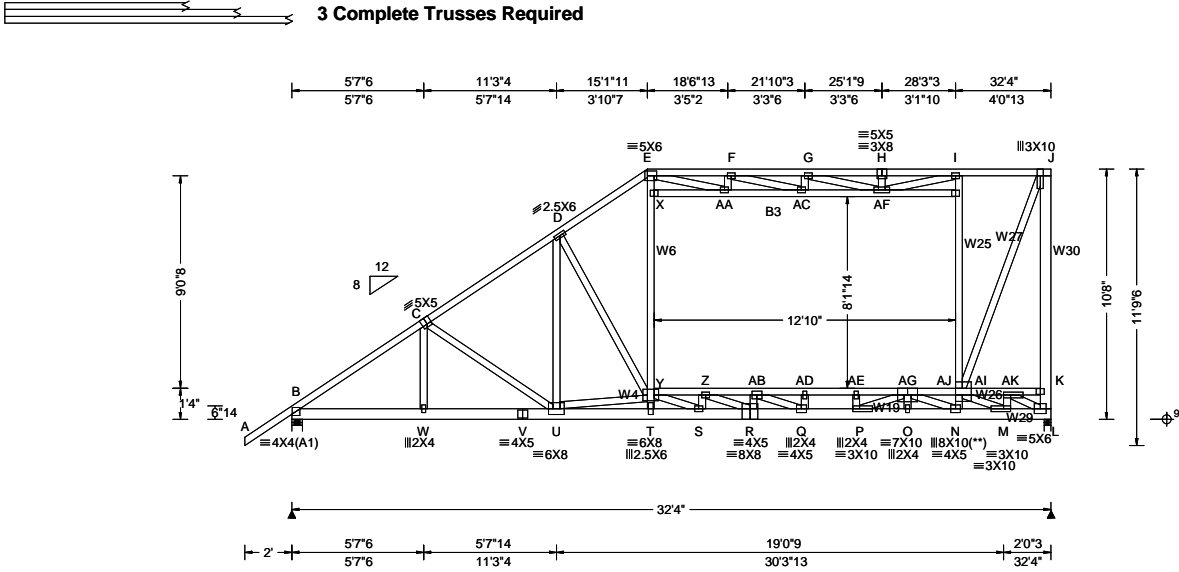

<b>Loading Criteria (psf)</b> TCLL: 20.00 TCDL: 10.00 BCLL: 0.00 BCDL: 10.00 Des Ld: 40.00 NCBCLL: 0.00 Soffit: 2.00 Load Duration: 1.00 Spacing: 16.0 "	<b>Wind Criteria</b> Wind Std: ASCE 7-22 Speed: 130 mph Enclosure: Enclosed Risk Category: II EXP: C Kzt: NA Mean Height: 17.41 ft TCDL: 5.0 psf BCDL: 5.0 psf MWFRS Parallel Dist: 0 to h/2 C&C Dist a: 3.23 ft Loc. from endwall: Any GCp: 0.18 Wind Duration: 1.60	<b>Snow Criteria (Pg,Pf in PSF)</b> Pg: NA Ct: NA CAT: NA Pf: NA Ce: NA Lu: NA Cs: NA Snow Duration: NA  Building Code: FBC 8th Ed. 2023 Res. TPI Std: 2014 Rep Fac: Yes FT/RT:20(0)/10(0) Plate Type(s): WAVE	<b>Defl/CSI Criteria</b> PP Deflection in loc L/defl L/# VERT(LL): 0.241 T 999 360 VERT(CL): 0.479 T 806 240 HORZ(LL): 0.149 AF - - HORZ(TL): 0.297 AF - - Creep Factor: 2.0 Max TC CSI: 0.582 Max BC CSI: 0.505 Max Web CSI: 0.736  VIEW Ver: 24.02.00D.0114.10	<b>▲ Maximum Reactions (lbs)</b> Gravity Non-Gravity Loc R+ / R- / Rh / Rw / U / RL B 3207 - / - / - / - /204 -/ L 4405 - / - / - / - /166 -/ Wind reactions based on MWFRS B Brg Wid = 5.5 Min Req = 1.5 (Truss) L Brg Wid = 3.5 Min Req = 1.5 (Truss) Bearings B & L are a rigid surface. Members not listed have forces less than 375# <b>Maximum Top Chord Forces Per Ply (lbs)</b> Chords Tens.Comp. Chords Tens. Comp. B - C 83 -1641 F - G 151 -1395 C - D 73 -1656 G - H 106 -1049 D - E 46 -1289 H - I 106 -1049 E - F 123 -1446 I - J 29 -991
---	--	--	---	--

**Lumber**  
Top chord: 2x4 SP M-31;  
Bot chord: 2x6 SP 2400f-2.0E; B3 2x4 SP M-31;  
Webs: 2x4 SP #3; W4,W19,W26,W27,W29 2x4 SP #2;  
W6,W25 2x4 SP M-31; W30 2x6 SP 2400f-2.0E;

**Nailnote**  
Nail Schedule: 0.128"x3", min. nails  
Top Chord: 1 Row @ 12.00" o.c.  
Bot Chord: 1 Row @ 8.00" o.c.  
Webs : 1 Row @ 4" o.c.  
Repeat nailing as each layer is applied. Use equal spacing between rows and stagger nails in each row to avoid splitting.

**Plating Notes**  
All plates are 3X4 except as noted.  
(\*\*) 1 plate(s) require special positioning. Refer to scaled plate plot details for special positioning requirements.

**Loading**  
Attic room loading from 15-5-3 to 28-3-3: Live Load: 40 PSF. Dead Load: 10 PSF Ceiling: 10 PSF, Kneewalls: 10 PSF

**Purlins**  
In lieu of rigid ceiling use purlins to brace BC @ 24" oc.  
Collar-tie braced with continuous lateral bracing at 24" oc. or rigid ceiling.

**Wind**  
Wind loads and reactions based on MWFRS.  
Right end vertical not exposed to wind pressure.  
Wind loading based on both gable and hip roof types.

**Additional Notes**  
The overall height of this truss excluding overhang is 10-8-0.

**Special loads**  
----- (Lumber Dur.Fac.=1.00 / Plate Dur.Fac.=1.00)  
TC: From 43 plf at -2.00 to 43 plf at 32.33  
PLT: From 13 plf at 15.43 to 13 plf at 28.27  
PLT: From 67 plf at 15.43 to 67 plf at 28.27  
BC: From 3 plf at -2.00 to 3 plf at 0.00  
BC: From 13 plf at 0.00 to 13 plf at 32.33  
BC: 2992 lb Conc. Load at 15.27  
BC: 109 lb Conc. Load at 15.43 26.27  
BC: 764 lb Conc. Load at 26.04  
BC: 236 lb Conc. Load at 27.50 29.50 31.50

**Maximum Bot Chord Forces Per Ply (lbs)**

Chords	Tens.Comp.	Chords	Tens. Comp.
B - W	1337 -62	R - Q	1863 -26
W - V	1338 -62	P - O	64 -1786
V - U	1338 -62	O - N	64 -1786
U - T	3657 -140	N - M	68 -3638
T - S	3839 -144	M - L	38 -1776
S - R	2866 -78		

**Maximum Web Forces Per Ply (lbs)**

Webs	Tens.Comp.	Webs	Tens. Comp.
U - D	654 -20	AC-AF	379 -121
U - Y	89 -2345	AD-AE	710 -73
D - Y	41 -638	AE-AG	755 -58
E - X	645 0	P - AG	2261 -41
X - Y	629 0	AG - N	5 -1654
Y - T	708 -21	AG-AI	4299 -99
Y - S	62 -878	N - AI	1220 -1
Y - Z	55 -2013	AI - M	1823 -28
S - Z	539 -29	AI-AK	2051 -44
Z - R	51 -912	AJ - J	2609 -76
Z - AB	1 -1036	M - AK	20 -899
AA-AC	446 -99	AK - L	1873 -39
R - AB	649 -24	K - J	78 -2402
AB - Q	57 -1711	K - L	78 -2396
AB-AD	679 -76		

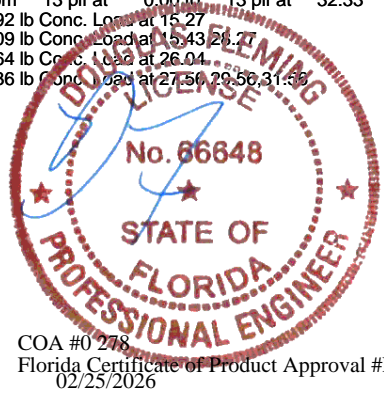

**\*\*WARNING\*\* READ AND FOLLOW ALL NOTES ON THIS DRAWING!**  
**\*\*IMPORTANT\*\* FURNISH THIS DRAWING TO ALL CONTRACTORS INCLUDING THE INSTALLERS**  
Trusses require extreme care in fabricating, handling, shipping, installing and bracing. Refer to and follow the latest edition of BCSI (Building Component Safety Information, by TPI and SBCA) for safety practices prior to performing these functions. Installers shall provide temporary bracing per BCSI. Unless noted otherwise, top chord shall have properly attached structural sheathing and bottom chord shall have a properly attached rigid ceiling. Locations shown for permanent lateral restraint of webs shall have continuous lateral restraint (CLR), installed with diagonal bracing installed on the CLR per BCSI sections B3, B7, or B10, as applicable. Apply plates to each face of truss and position as shown above and on the Joint Details, unless noted otherwise. Refer to drawings 160A-Z for standard plate positions. Refer to job's General Notes page for additional information.  
Alpine, a division of ITW Building Components Group Inc. shall not be responsible for any deviation from this drawing, any failure to build the truss in conformance with ANSI/TPI 1, or for handling, shipping, installation and bracing of trusses. A seal on this drawing or cover page listing this drawing, indicates acceptance of professional engineering responsibility solely for the design shown. The suitability and use of this drawing for any structure is the responsibility of the Building Designer per ANSI/TPI 1 Sec.2.  
For more information see these web sites: Alpine: alpineitw.com; TPI: tpinst.org; SBCA: sbcacomponents.com; ICC: iccsafe.org; AWC: awc.org

155 Harlem Ave  
 North Building, 4th Floor  
 Glenview, IL 60025

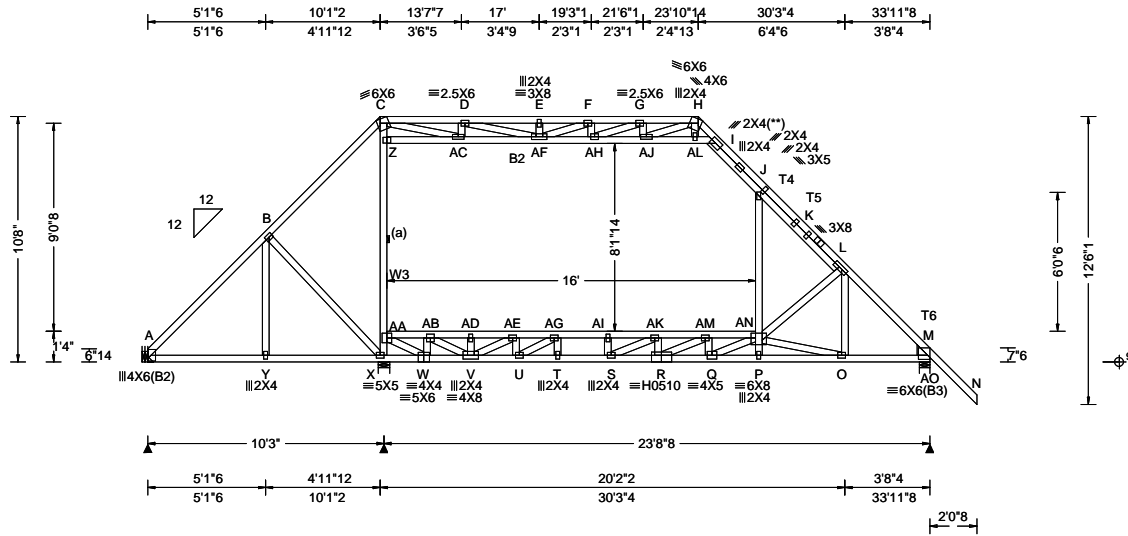

<b>Loading Criteria (psf)</b> TCLL: 20.00 TCDL: 10.00 BCLL: 0.00 BCDL: 10.00 Des Ld: 40.00 NCBCLL: 10.00 Soffit: 2.00 Load Duration: 1.25 Spacing: 19.2 "	<b>Wind Criteria</b> Wind Std: ASCE 7-22 Speed: 130 mph Enclosure: Enclosed Risk Category: II EXP: C Kzt: NA Mean Height: 17.07 ft TCDL: 5.0 psf BCDL: 5.0 psf MWFRS Parallel Dist: 0 to h/2 C&C Dist a: 3.40 ft Loc. from endwall: Any GCpi: 0.18 Wind Duration: 1.60	<b>Snow Criteria (Pg,Pf in PSF)</b> Pg: NA Ct: NA CAT: NA Pf: NA Ce: NA Lu: NA Cs: NA Snow Duration: NA  Building Code: FBC 8th Ed. 2023 Res. TPI Std: 2014 Rep Fac: Yes FT/RT:20(0)/10(0) Plate Type(s): WAVE, HS	<b>Defl/CSI Criteria</b> PP Deflection in loc L/defl L/# VERT(LL): 0.289 AK 987 360 VERT(CL): 0.568 S 503 240 HORZ(LL): -0.135 J - - HORZ(TL): 0.267 J - - Creep Factor: 2.0 Max TC CSI: 0.519 Max BC CSI: 0.512 Max Web CSI: 0.598  VIEW Ver: 24.02.00D.0114.10	<b>▲ Maximum Reactions (lbs)</b> Gravity Loc R+ / R- / Rh / Rw / U / RL A 1766 - / - / - / 879 / 106 / 421 X 558 - / - / - / 519 / 366 - / - AO 2147 - / - / - / 834 / 134 - / - Wind reactions based on MWFRS A Brg Wid = - Min Req = - X Brg Wid = 6.0 Min Req = 1.5 (Truss) AO Brg Wid = 5.5 Min Req = 1.8 (Truss) Bearings X & AO are a rigid surface. Members not listed have forces less than 375# <b>Maximum Top Chord Forces Per Ply (lbs)</b> Chords Tens.Comp. Chords Tens. Comp.
--	---	--	---	--

**Lumber**  
Top chord: 2x4 SP #2; T4,T5,T6 2x4 SP M-31;  
Bot chord: 2x4 SP M-31; B2 2x4 SP #2;  
Webs: 2x4 SP #3; W3 2x4 SP M-31;  
Rt Wedge: 2x6 SP #2;

**Plating Notes**  
All plates are 3X4 except as noted.  
(\*\*) 1 plate(s) require special positioning. Refer to scaled plate plot details for special positioning requirements.

**Loading**  
Attic room loading from 10-4-10 to 26-4-10: Live Load: 40 PSF. Dead Load: 10 PSF Ceiling: 10 PSF, Kneewalls: 10 PSF

**Purlins**  
Collar-tie braced with continuous lateral bracing at 24" oc. or rigid ceiling.

**Wind**  
Wind loads based on MWFRS with additional C&C member design.  
Wind loading based on both gable and hip roof types.

**Additional Notes**  
The overall height of this truss excluding overhang is 10-8-0.



<b>Maximum Bot Chord Forces Per Ply (lbs)</b>			
Chords	Tens.Comp.	Chords	Tens. Comp.
A - Y	1498 -21	T - S	4449 0
Y - X	1498 -21	S - R	4124 0
X - W	1053 0	R - Q	3341 -78
W - V	2395 0	Q - P	2145 -325
V - U	4014 0	P - O	2119 -317
U - T	4441 0	O - M	1697 -16
<b>Maximum Web Forces Per Ply (lbs)</b>			
Webs	Tens.Comp.	Webs	Tens. Comp.
C - Z	1068 -282	AG-AI	0 -2992
C -AC	1160 -238	AH-G	716 -157
X -AA	444 -314	AH-AJ	97 -398
Z -AA	1044 -284	AI-AK	0 -2970
Z -AC	35 -387	S -AK	415 -62
AA -W	1269 0	G -AJ	99 -428
AA-AB	0 -801	AJ-AL	243 -1264
W -AB	0 -727	AJ -H	1125 -239
AB -V	1123 0	AK-AM	101 -2569
AB-AD	0 -1908	R -AM	829 0
AC-AF	815 -217	AL -I	244 -1274
V -AE	0 -755	AM -Q	37 -486
AD-AE	0 -1908	AM-AN	240 -1771

**\*\*WARNING\*\* READ AND FOLLOW ALL NOTES ON THIS DRAWING!**  
**\*\*IMPORTANT\*\* FURNISH THIS DRAWING TO ALL CONTRACTORS INCLUDING THE INSTALLERS**  
Trusses require extreme care in fabricating, handling, shipping, installing and bracing. Refer to and follow the latest edition of BCSI (Building Component Safety Information, by TPI and SBCA) for safety practices prior to performing these functions. Installers shall provide temporary bracing per BCSI. Unless noted otherwise, top chord shall have properly attached structural sheathing and bottom chord shall have a properly attached rigid ceiling. Locations shown for permanent lateral restraint of webs shall have continuous lateral restraint (CLR), installed with diagonal bracing installed on the CLR per BCSI sections B3, B7, or B10, as applicable. Apply plates to each face of truss and position as shown above and on the Joint Details, unless noted otherwise. Refer to drawings 160A-Z for standard plate positions. Refer to job's General Notes page for additional information.  
Alpine, a division of ITW Building Components Group Inc. shall not be responsible for any deviation from this drawing, any failure to build the truss in conformance with ANSI/TPI 1, or for handling, shipping, installation and bracing of trusses. A seal on this drawing or cover page listing this drawing, indicates acceptance of professional engineering responsibility solely for the design shown. The suitability and use of this drawing for any structure is the responsibility of the Building Designer per ANSI/TPI 1 Sec.2.  
For more information see these web sites: Alpine: alpineitw.com; TPI: tpinst.org; SBCA: sbcacomponents.com; ICC: iccsafe.org; AWC: awc.org



**Hangers / Ties**

Simpson Construction Hardware is specified based on the most current information provided by Simpson Strong-Tie. Please refer to the most recent Simpson Strong-Tie catalog for additional information.

Recommended hanger connections are based on manufacturer tested capacities and calculations. Conditions may exist that require different connections than indicated. Refer to manufacturer publication for additional information.

Hanger specified assumes connection to supporting chord is located a minimum of five times the depth of the supporting chord from any unsupported end, unless unsupported chord end has 85% plating coverage.

Bearing at location x=0' uses the following support conditions: 0'

Bearing A (0', 9') HUS26

Supporting Member: (2)2x6 SP 2400f-2.0E

(14) 0.148"x3" nails into supporting member,

(4) 0.148"x3" nails into supported member.

AE-AG	0	-2631	Q-AN	1256	-38
U-AG	65	-434	AN-J	980	0
AF-AH	654	-180	AN-O	325	-433

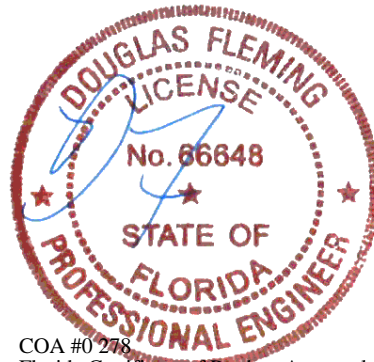

COA #0 278  
 Florida Certificate of Product Approval #FL1999  
 02/25/2026

**\*\*WARNING\*\* READ AND FOLLOW ALL NOTES ON THIS DRAWING!**  
**\*\*IMPORTANT\*\* FURNISH THIS DRAWING TO ALL CONTRACTORS INCLUDING THE INSTALLERS**  
 Trusses require extreme care in fabricating, handling, shipping, installing and bracing. Refer to and follow the latest edition of BCSI (Building Component Safety Information, by TPI and SBCA) for safety practices prior to performing these functions. Installers shall provide temporary bracing per BCSI. Unless noted otherwise, top chord shall have properly attached structural sheathing and bottom chord shall have a properly attached rigid ceiling. Locations shown for permanent lateral restraint of webs shall have continuous lateral restraint (CLR), installed with diagonal bracing installed on the CLR per BCSI sections B3, B7, or B10, as applicable. Apply plates to each face of truss and position as shown above and on the Joint Details, unless noted otherwise. Refer to drawings 160A-Z for standard plate positions. Refer to job's General Notes page for additional information.  
 Alpine, a division of ITW Building Components Group Inc. shall not be responsible for any deviation from this drawing, any failure to build the truss in conformance with ANSI/TPI 1, or for handling, shipping, installation and bracing of trusses. A seal on this drawing or cover page listing this drawing, indicates acceptance of professional engineering responsibility solely for the design shown. The suitability and use of this drawing for any structure is the responsibility of the Building Designer per ANSI/TPI 1 Sec.2.  
 For more information see these web sites: Alpine: [alpineitw.com](http://alpineitw.com); TPI: [tpinst.org](http://tpinst.org); SBCA: [sbcacomponents.com](http://sbcacomponents.com); ICC: [iccsafe.org](http://iccsafe.org); AWC: [awc.org](http://awc.org)



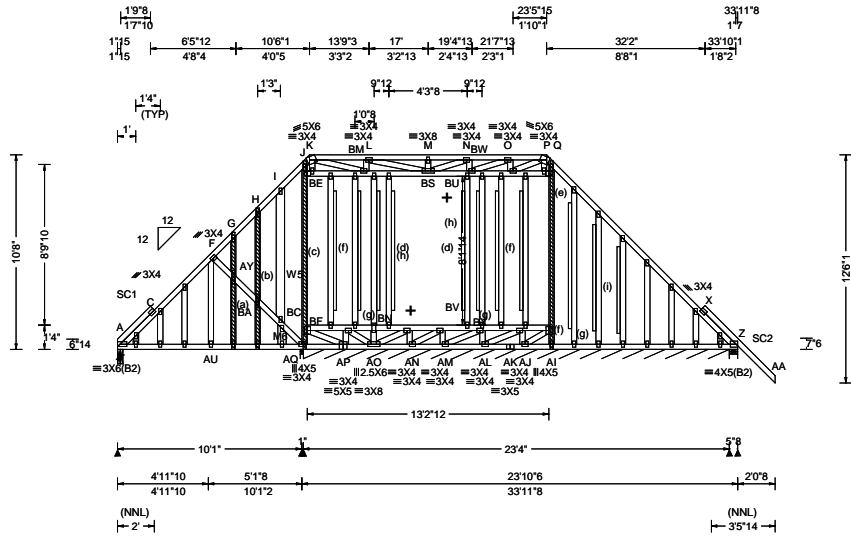

<b>Loading Criteria (psf)</b>	<b>Wind Criteria</b>	<b>Snow Criteria (Pg,Pf in PSF)</b>	<b>Defl/CSI Criteria</b>	<b>▲ Maximum Reactions (lbs), or *PLF</b>	
TCLL: 20.00	Wind Std: ASCE 7-22	Pg: NA Ct: NA CAT: NA	PP Deflection in loc L/defl L/#	Gravity Non-Gravity	
TCDL: 10.00	Speed: 130 mph	Pf: NA Ce: NA	VERT(LL): 0.027 AW999 360	Loc R+ / R- / Rh / Rw / U / RL	
BCLL: 0.00	Enclosure: Enclosed	Lu: NA Cs: NA	VERT(CL): 0.075 AW999 240	A 609 /- /- /366 /22 /513	
BCDL: 10.00	Risk Category: II	Snow Duration: NA	HORZ(LL): 0.024 D - -	AQ 1092 /- /- /802 /249 /-	
Des Ld: 40.00	EXP: C Kzt: NA	Building Code:	HORZ(TL): 0.066 D - -	AQ*146 /- /- /173 /- /-	
NCBCLL: 10.00	Mean Height: 17.07 ft	FBC 8th Ed. 2023 Res.	Creep Factor: 2.0	Z 529 /- /- /263 /152 /-	
Soffit: 2.00	TCDL: 5.0 psf	TPI Std: 2014	Max TC CSI: 0.595	<b>Wind reactions based on MWFRS</b>	
Load Duration: 1.25	BCDL: 5.0 psf	Rep Fac: Varies by Ld Case	Max BC CSI: 0.460	A Brg Wid = 3.5 Min Req = 1.5 (Truss)	
Spacing: 24.0 "	MWFRS Parallel Dist: 0 to h/2	FT/RT:20(0)/10(0)	Max Web CSI: 0.997	AQ Brg Wid = 2.0 Min Req = 1.5 (Truss)	
	C&C Dist a: 3.40 ft	Plate Type(s):	VIEW Ver: 24.02.00D.0114.10	AQ Brg Wid = 280 Min Req = -	
	Loc. from endwall: Any	WAVE		Z Brg Wid = 5.5 Min Req = 1.5 (Truss)	
	GCp: 0.18			Bearings A, AQ, AQ, & Z are a rigid surface.	
	Wind Duration: 1.60			Members not listed have forces less than 375#	

**Lumber**  
 Top chord: 2x4 SP #2;  
 Bot chord: 2x4 SP #2;  
 Webs: 2x4 SP #3; W5, M6 2x6 SP 2400f-2.0E;  
 Stack Chord: SC1 2x4 SP #2;  
 Stack Chord: SC2 2x4 SP #2;

**Plating Notes**  
 All plates are 2X4 except as noted.

**Loading**  
 Truss designed to support 1-4-0 top chord outlookers and cladding load not to exceed 5.00 PSF one face and 24.0' span opposite face. Top chord must not be cut or notched, unless specified otherwise.  
 Attic room loading from 10-4-10 to 23-7-6: Live Load: 40 PSF. Dead Load: 10 PSF Ceiling: 10 PSF, Kneewalls: 10 PSF

**Purlins**  
 Collar-tie braced with continuous lateral bracing at 24" oc. or rigid ceiling.

**Wind**  
 Wind loads based on MWFRS with additional C&C member design.  
 Wind loading based on both gable and hip roof types.  
 Gable meets L/120 deflection criteria for wind load applied to face. Calculated deflection ratio is L/130.  
**+ MEMBER TO BE LATERALLY BRACED FOR HORIZONTAL WIND LOADS.**

**Additional Notes**  
 Exposed portion of gable face shall be reinforced with sheathing and the wind pressures shall be transferred into lateral diaphragms. Connections and designs for diaphragms is the responsibility of the Building Designer in accordance with ANSI/TPI 1.  
 Stacked top chord must NOT be notched or cut in area (NNL). Dropped top chord braced at 24" oc intervals. Attach stacked top chord (SC) to dropped top chord in notchable area using 3x4 tie-plates 24" oc. Center plate on stacked/dropped chord interface, plate length perpendicular to chord length. Splice top chord in notchable area using 3x6.  
 The overall height of this truss excluding overhang is 10-8-0.

**Maximum Top Chord Forces Per Ply (lbs)**

Chords	Tens.Comp.	Chords	Tens. Comp.
C - F	162 -530	M - N	425 -592
L - M	425 -592	Q - X	282 -385

**Maximum Bot Chord Forces Per Ply (lbs)**

Chords	Tens.Comp.	Chords	Tens. Comp.
A - AU	484 -175	AL-AK	400 -113
AU-AQ	473 -174	AK-AJ	400 -113
AQ-AP	587 -178	AJ-AI	580 -175
AP-AO	485 -126	AI - Z	575 -175

**Maximum Web Forces Per Ply (lbs)**

Webs	Tens.Comp.	Webs	Tens. Comp.
F - AY	393 -554	L - BS	456 -80
AY-BA	371 -528	BN-AO	36 -517
BA-BC	400 -571	M - BS	89 -465
BC-AQ	413 -582	BS - N	575 -106
AQ-BF	50 -453	N - BW	95 -643
BE-BF	58 -438	BU-BV	65 -419
BM - L	16 -798	BX-AL	86 -677

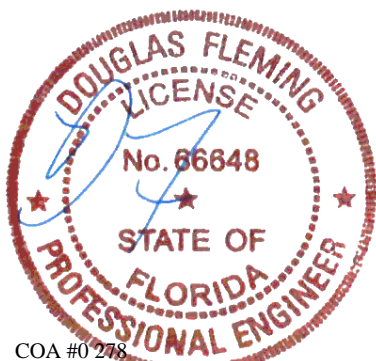

COA #0 278  
 Florida Certificate of Product Approval #FL1999  
 02/25/2026

**\*\*WARNING\*\* READ AND FOLLOW ALL NOTES ON THIS DRAWING!**  
**\*\*IMPORTANT\*\* FURNISH THIS DRAWING TO ALL CONTRACTORS INCLUDING THE INSTALLERS**  
 Trusses require extreme care in fabricating, handling, shipping, installing and bracing. Refer to and follow the latest edition of BCSI (Building Component Safety Information, by TPI and SBCA) for safety practices prior to performing these functions. Installers shall provide temporary bracing per BCSI. Unless noted otherwise, top chord shall have properly attached structural sheathing and bottom chord shall have a properly attached rigid ceiling. Locations shown for permanent lateral restraint of webs shall have continuous lateral restraint (CLR), installed with diagonal bracing installed on the CLR per BCSI sections B3, B7, or B10, as applicable. Apply plates to each face of truss and position as shown above and on the Joint Details, unless noted otherwise. Refer to drawings 160A-Z for standard plate positions. Refer to job's General Notes page for additional information.  
 Alpine, a division of ITW Building Components Group Inc. shall not be responsible for any deviation from this drawing, any failure to build the truss in conformance with ANSI/TPI 1, or for handling, shipping, installation and bracing of trusses. A seal on this drawing or cover page listing this drawing, indicates acceptance of professional engineering responsibility solely for the design shown. The suitability and use of this drawing for any structure is the responsibility of the Building Designer per ANSI/TPI 1 Sec.2.  
 For more information see these web sites: Alpine: alpineitw.com; TPI: tpinst.org; SBCA: sbcacomponents.com; ICC: iccsafe.org; AWC: awc.org



**Gable Reinforcement**

- (a) 2x3 "T" reinforcement. Same species and grade as web. Full truss height along web member. Attach to the wide face with 10d (0.131"x3",min.) nails @ 4" oc in the web plus (2)10d (0.131"x3",min.) nails in each chord.
- (b) 2x4 "T" reinforcement. Same species and grade as web. Full truss height along web member. Attach to the wide face with 10d (0.131"x3",min.) nails @ 4" oc in the web plus (2)10d (0.131"x3",min.) nails in each chord.
- (c) 2x4 SP/DF #2 or better "T" reinforcement. Full truss height along web member. Attach to the wide face with 10d (0.131"x3",min.) nails @ 4" oc in the web plus (2)10d (0.131"x3",min.) nails in each chord.
- (d) 2x6 "L" reinforcement. Same species and grade as web. 80% length of web member. Attach with 10d (0.131"x3",min.) nails @ 2" oc at each end for the first 18" and then 4" oc for the remainder.
- (e) 2x6 "T" reinforcement. Any species and grade. Full truss height along web member. Attach to the wide face with 10d (0.131"x3",min.) nails @ 4" oc in the web plus (2)10d (0.131"x3",min.) nails in each chord.
- (f) 2x6 "L" reinforcement. Any species and grade. 80% length of web member. Attach with 10d (0.131"x3",min.) nails @ 2" oc at each end for the first 18" and then 4" oc for the remainder.
- (g) 2x4 "L" reinforcement. Same species and grade as web. 80% length of web member. Attach with 10d (0.131"x3",min.) nails @ 2" oc at each end for the first 18" and then 4" oc for the remainder.
- (h) 2x4 "L" reinforcement. Any species and grade. 80% length of web member. Attach with 10d (0.131"x3",min.) nails @ 2" oc at each end for the first 18" and then 4" oc for the remainder.
- (i) 2x3 "L" reinforcement. Same species and grade as web. 80% length of web member. Attach with 10d (0.131"x3",min.) nails @ 2" oc at each end for the first 18" and then 4" oc for the remainder.

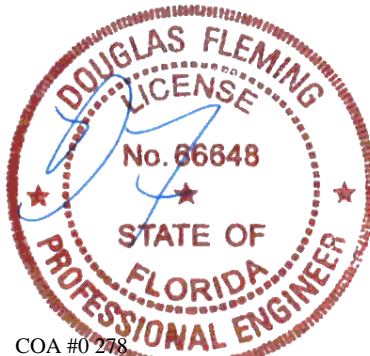

COA #0 278  
 Florida Certificate of Product Approval #FL1999  
 02/25/2026

**\*\*WARNING\*\* READ AND FOLLOW ALL NOTES ON THIS DRAWING!**  
**\*\*IMPORTANT\*\* FURNISH THIS DRAWING TO ALL CONTRACTORS INCLUDING THE INSTALLERS**  
 Trusses require extreme care in fabricating, handling, shipping, installing and bracing. Refer to and follow the latest edition of BCSI (Building Component Safety Information, by TPI and SBCA) for safety practices prior to performing these functions. Installers shall provide temporary bracing per BCSI. Unless noted otherwise, top chord shall have properly attached structural sheathing and bottom chord shall have a properly attached rigid ceiling. Locations shown for permanent lateral restraint of webs shall have continuous lateral restraint (CLR), installed with diagonal bracing installed on the CLR per BCSI sections B3, B7, or B10, as applicable. Apply plates to each face of truss and position as shown above and on the Joint Details, unless noted otherwise. Refer to drawings 160A-Z for standard plate positions. Refer to job's General Notes page for additional information.  
 Alpine, a division of ITW Building Components Group Inc. shall not be responsible for any deviation from this drawing, any failure to build the truss in conformance with ANSI/TPI 1, or for handling, shipping, installation and bracing of trusses. A seal on this drawing or cover page listing this drawing, indicates acceptance of professional engineering responsibility solely for the design shown. The suitability and use of this drawing for any structure is the responsibility of the Building Designer per ANSI/TPI 1 Sec.2.  
 For more information see these web sites: Alpine: [alpineitw.com](http://alpineitw.com); TPI: [tpinst.org](http://tpinst.org); SBCA: [sbcacomponents.com](http://sbcacomponents.com); ICC: [iccsafe.org](http://iccsafe.org); AWC: [awc.org](http://awc.org)



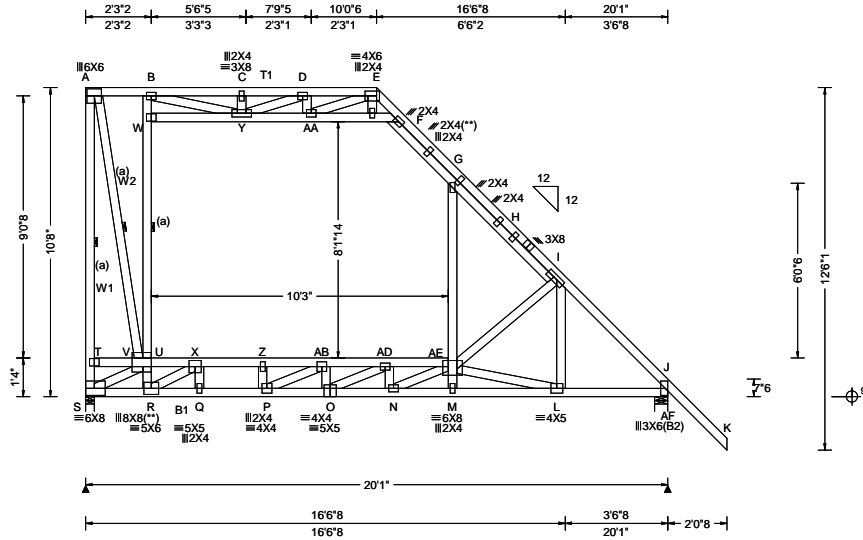

<b>Loading Criteria (psf)</b> TCLL: 20.00 TCDL: 10.00 BCLL: 0.00 BCDL: 10.00 Des Ld: 40.00 NCBCLL: 10.00 Soffit: 2.00 Load Duration: 1.25 Spacing: 24.0 "	<b>Wind Criteria</b> Wind Std: ASCE 7-22 Speed: 130 mph Enclosure: Enclosed Risk Category: II EXP: C Kzt: NA Mean Height: 15.00 ft TCDL: 5.0 psf BCDL: 5.0 psf MWFRS Parallel Dist: h/2 to h C&C Dist a: 3.00 ft Loc. from endwall: not in 9.00 ft GCp: 0.18 Wind Duration: 1.60	<b>Snow Criteria (Pg,Pf in PSF)</b> Pg: NA Ct: NA CAT: NA Pf: NA Ce: NA Lu: NA Cs: NA Snow Duration: NA  Building Code: FBC 8th Ed. 2023 Res. TPI Std: 2014 Rep Fac: Yes FT/RT:20(0)/10(0) Plate Type(s): WAVE	<b>Defl/CSI Criteria</b> PP Deflection in loc L/defl L/# VERT(LL): 0.230 N 999 360 VERT(CL): 0.467 N 515 240 HORZ(LL): -0.183 F - - HORZ(TL): 0.376 F - - Creep Factor: 2.0 Max TC CSI: 0.621 Max BC CSI: 0.923 Max Web CSI: 0.863  VIEW Ver: 24.02.00D.0114.10	<b>▲ Maximum Reactions (lbs)</b> Gravity Loc R+ / R- / Rh / Rw / U / RL S 1829 - / - / 529 / 236 / 414 AF 1575 - / - / 593 / 62 - Wind reactions based on MWFRS S Brg Wid = 3.5 Min Req = 1.5 (Truss) AF Brg Wid = 5.5 Min Req = 1.9 (Truss) Bearings S & AF are a rigid surface. Members not listed have forces less than 375# <b>Maximum Top Chord Forces Per Ply (lbs)</b> Chords Tens.Comp. Chords Tens. Comp. F - G 1214 0 E - F 483 -682 A - B 175 -622 G - H 1115 -41 B - C 710 -1017 H - I 59 -1477 C - D 710 -1017 I - J 187 -1732 D - E 762 -1035
--	---	--	--	---

**Lumber**  
Top chord: 2x4 SP M-31; T1 2x4 SP #2;  
Bot chord: 2x4 SP #2; B1 2x4 SP M-31;  
Webs: 2x4 SP #3; W1 2x4 SP M-31; W2 2x4 SP #2;

**Additional Notes**  
The overall height of this truss excluding overhang is 108-0.

**Bracing**  
(a) Continuous lateral restraint equally spaced on member.

**Plating Notes**  
All plates are 3X4 except as noted.  
(\*\*) 2 plate(s) require special positioning. Refer to scaled plate plot details for special positioning requirements.

**Loading**  
Attic room loading from 2-3-2 to 12-6-2: Live Load: 40 PSF. Dead Load: 10 PSF Ceiling: 10 PSF, Kneewalls: 10 PSF

**Purlins**  
Collar-tie braced with continuous lateral bracing at 24" oc. or rigid ceiling.

**Wind**  
Wind loads based on MWFRS with additional C&C member design.  
Left end vertical not exposed to wind pressure.  
Wind loading based on both gable and hip roof types.

<b>Maximum Bot Chord Forces Per Ply (lbs)</b>	Chords Tens.Comp.	Chords Tens. Comp.		
S - R	932 -2087	O - N	2928	-343
R - Q	777 -251	N - M	3314	-998
Q - P	856 -226	M - L	3237	-970
P - O	2448 0	L - J	1119	0

<b>Maximum Web Forces Per Ply (lbs)</b>	Webs Tens.Comp.	Webs Tens. Comp.		
A - T	836 -2876	Z - P	407	-119
A - U	2969 -834	P - AB	526	-1988
S - T	828 -2843	AA - E	478	-339
S - U	2267 -482	AB - O	497	-208
U - W	470 -559	AB-AD	278	-1925
U - X	2302 -601	O - AD	375	-413
V - R	1537 -162	AD-AE	679	-2345
W - B	461 -520	N - AE	639	-557
R - X	388 -2645	AE - L	1062	-2174
B - Y	561 -607	AE - I	281	-621
X - Q	681 -105	L - I	545	-214
Y - AA	453 -613			

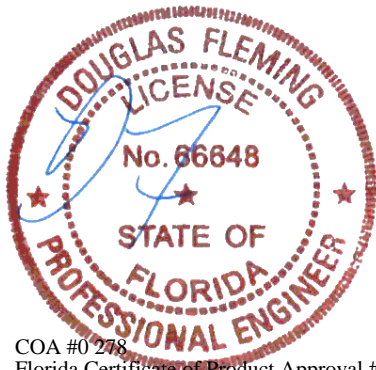

COA #0 278  
Florida Certificate of Product Approval #FL1999  
02/25/2026

**\*\*WARNING\*\* READ AND FOLLOW ALL NOTES ON THIS DRAWING!**  
**\*\*IMPORTANT\*\* FURNISH THIS DRAWING TO ALL CONTRACTORS INCLUDING THE INSTALLERS**  
Trusses require extreme care in fabricating, handling, shipping, installing and bracing. Refer to and follow the latest edition of BCSI (Building Component Safety Information, by TPI and SBCA) for safety practices prior to performing these functions. Installers shall provide temporary bracing per BCSI. Unless noted otherwise, top chord shall have properly attached structural sheathing and bottom chord shall have a properly attached rigid ceiling. Locations shown for permanent lateral restraint of webs shall have continuous lateral restraint (CLR), installed with diagonal bracing installed on the CLR per BCSI sections B3, B7, or B10, as applicable. Apply plates to each face of truss and position as shown above and on the Joint Details, unless noted otherwise. Refer to drawings 160A-Z for standard plate positions. Refer to job's General Notes page for additional information.  
Alpine, a division of ITW Building Components Group Inc. shall not be responsible for any deviation from this drawing, any failure to build the truss in conformance with ANSI/TPI 1, or for handling, shipping, installation and bracing of trusses. A seal on this drawing or cover page listing this drawing, indicates acceptance of professional engineering responsibility solely for the design shown. The suitability and use of this drawing for any structure is the responsibility of the Building Designer per ANSI/TPI 1 Sec.2.  
For more information see these web sites: Alpine: alpineitw.com; TPI: tpinst.org; SBCA: sbcacomponents.com; ICC: iccsafe.org; AWC: awc.org



SEQN: 728249 FROM: RFG	GABL Ply: 1 Qty: 1	Job Number: 26-3388d JOHNSON Truss Label: C2E	Cust: R 215 JRef: 1YHX2150002 T3 DrwNo: 056.26.0835.49523 JB / DF 02/25/2026
---------------------------	--------------------------	---	--

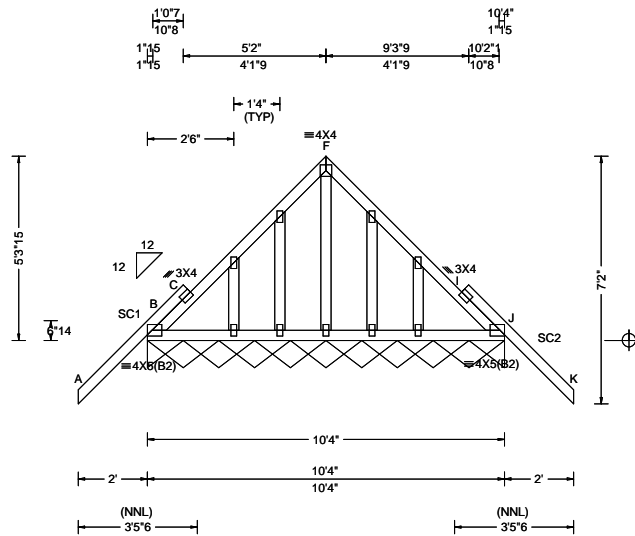

<b>Loading Criteria (psf)</b> TCCL: 20.00 TCDL: 10.00 BCLL: 0.00 BCDL: 10.00 Des Ld: 40.00 NCBCLL: 10.00 Soffit: 2.00 Load Duration: 1.25 Spacing: 24.0 "	<b>Wind Criteria</b> Wind Std: ASCE 7-22 Speed: 130 mph Enclosure: Enclosed Risk Category: II EXP: C Kzt: NA Mean Height: 15.00 ft TCDL: 5.0 psf BCDL: 5.0 psf MWFRS Parallel Dist: 0 to h/2 C&C Dist a: 3.00 ft Loc. from endwall: Any GCp: 0.18 Wind Duration: 1.60	<b>Snow Criteria (Pg,Pf in PSF)</b> Pg: NA Ct: NA CAT: NA Pf: NA Ce: NA Lu: NA Cs: NA Snow Duration: NA  Building Code: FBC 8th Ed. 2023 Res. TPI Std: 2014 Rep Fac: Varies by Ld Case FT/RT:20(0)/10(0) Plate Type(s): WAVE	<b>Defl/CSI Criteria</b> PP Deflection in loc L/defl L/# VERT(LL): -0.003 C 999 360 VERT(CL): -0.006 C 999 240 HORZ(LL): 0.004 I - - HORZ(TL): 0.008 I - - Creep Factor: 2.0 Max TC CSI: 0.770 Max BC CSI: 0.150 Max Web CSI: 0.686  VIEW Ver: 24.02.00D.0114.10	<b>▲ Maximum Reactions (lbs), or *=PLF</b> <table border="1"> <thead> <tr> <th colspan="2">Gravity</th> <th colspan="4">Non-Gravity</th> </tr> <tr> <th>Loc</th> <th>R+ / R-</th> <th>/ Rh</th> <th>/ Rw</th> <th>/ U</th> <th>/ RL</th> </tr> </thead> <tbody> <tr> <td>J*</td> <td>170</td> <td>-</td> <td>-</td> <td>171</td> <td>158 / 22</td> </tr> </tbody> </table> Wind reactions based on MWFRS J Brg Wid = 123 Min Req = - Bearing B is a rigid surface. Members not listed have forces less than 375# <b>Maximum Top Chord Forces Per Ply (lbs)</b> <table border="1"> <thead> <tr> <th>Chords</th> <th>Tens.Comp.</th> <th>Chords</th> <th>Tens. Comp.</th> </tr> </thead> <tbody> <tr> <td>B - C</td> <td>771 -957</td> <td>I - J</td> <td>732 -965</td> </tr> </tbody> </table> <b>Maximum Bot Chord Forces Per Ply (lbs)</b> <table border="1"> <thead> <tr> <th>Chords</th> <th>Tens.Comp.</th> </tr> </thead> <tbody> <tr> <td>B - J</td> <td>563 -70</td> </tr> </tbody> </table>	Gravity		Non-Gravity				Loc	R+ / R-	/ Rh	/ Rw	/ U	/ RL	J*	170	-	-	171	158 / 22	Chords	Tens.Comp.	Chords	Tens. Comp.	B - C	771 -957	I - J	732 -965	Chords	Tens.Comp.	B - J	563 -70
Gravity		Non-Gravity																																
Loc	R+ / R-	/ Rh	/ Rw	/ U	/ RL																													
J*	170	-	-	171	158 / 22																													
Chords	Tens.Comp.	Chords	Tens. Comp.																															
B - C	771 -957	I - J	732 -965																															
Chords	Tens.Comp.																																	
B - J	563 -70																																	

**Lumber**  
 Top chord: 2x4 SP #2;  
 Bot chord: 2x4 SP #2;  
 Webs: 2x4 SP #3;  
 Stack Chord: SC1 2x4 SP #2;  
 Stack Chord: SC2 2x4 SP #2;

**Plating Notes**  
 All plates are 2X4 except as noted.

**Loading**  
 Truss designed to support 1-4-0 top chord outlookers and cladding load not to exceed 5.00 PSF one face and 24.0" span opposite face. Top chord must not be cut or notched, unless specified otherwise.

**Wind**  
 Wind loads based on MWFRS with additional C&C member design.  
 Wind loading based on both gable and hip roof types.  
 Gable meets L/120 deflection criteria for wind load applied to face. Calculated deflection ratio is L/330.

**Additional Notes**  
 Exposed portion of gable face shall be reinforced with sheathing and the wind pressures shall be transferred into lateral diaphragms. Connections and designs for diaphragms is the responsibility of the Building Designer in accordance with ANSI/TPI 1.  
 Stacked top chord must NOT be notched or cut in area (NNL). Dropped top chord braced at 24" oc intervals. Attach stacked top chord (SC) to dropped top chord in notchable area using 3x4 tie-plates 24" oc. Center plate on stacked/dropped chord interface, plate length perpendicular to chord length. Splice top chord in notchable area using 3x6.  
 The overall height of this truss excluding overhang is 5-3-15.

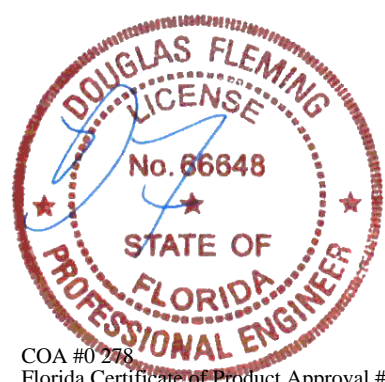

COA #0 278  
 Florida Certificate of Product Approval #FL1999  
 02/25/2026

**\*\*WARNING\*\* READ AND FOLLOW ALL NOTES ON THIS DRAWING!**  
**\*\*IMPORTANT\*\* FURNISH THIS DRAWING TO ALL CONTRACTORS INCLUDING THE INSTALLERS**  
 Trusses require extreme care in fabricating, handling, shipping, installing and bracing. Refer to and follow the latest edition of BCSI (Building Component Safety Information, by TPI and SBCA) for safety practices prior to performing these functions. Installers shall provide temporary bracing per BCSI. Unless noted otherwise, top chord shall have properly attached structural sheathing and bottom chord shall have a properly attached rigid ceiling. Locations shown for permanent lateral restraint of webs shall have continuous lateral restraint (CLR), installed with diagonal bracing installed on the CLR per BCSI sections B3, B7, or B10, as applicable. Apply plates to each face of truss and position as shown above and on the Joint Details, unless noted otherwise. Refer to drawings 160A-Z for standard plate positions. Refer to job's General Notes page for additional information.  
 Alpine, a division of ITW Building Components Group Inc. shall not be responsible for any deviation from this drawing, any failure to build the truss in conformance with ANSI/TPI 1, or for handling, shipping, installation and bracing of trusses. A seal on this drawing or cover page listing this drawing, indicates acceptance of professional engineering responsibility solely for the design shown. The suitability and use of this drawing for any structure is the responsibility of the Building Designer per ANSI/TPI 1 Sec.2.  
 For more information see these web sites: Alpine: alpineitw.com; TPI: tpinst.org; SBCA: sbccomponents.com; ICC: iccsafe.org; AWC: awc.org



2 Complete Trusses Required

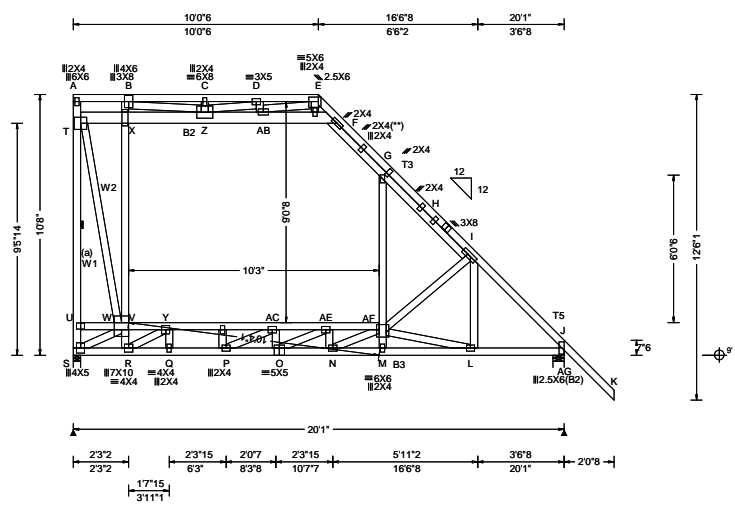

<b>Loading Criteria (psf)</b> TCCL: 20.00 TCCL: 10.00 BCLL: 0.00 BCDL: 10.00 Des Ld: 40.00 NCBCLL: 0.00 Soffit: 2.00 Load Duration: 1.00 Spacing: 24.0 "	<b>Wind Criteria</b> Wind Std: ASCE 7-22 Speed: 130 mph Enclosure: Enclosed Risk Category: II EXP: C Kzt: NA Mean Height: 15.00 ft TCCL: 5.0 psf BCDL: 5.0 psf MWFRS Parallel Dist: h to 2h C&C Dist a: 3.00 ft Loc. from endwall: not in 9.00 ft GCp: 0.18 Wind Duration: 1.60	<b>Snow Criteria (Pg,Pf in PSF)</b> Pg: NA Ct: NA CAT: NA Pf: NA Ce: NA Lu: NA Cs: NA Snow Duration: NA Building Code: FBC 8th Ed. 2023 Res. TPI Std: 2014 Rep Fac: Varies by Ld Case FT/RT:20(0)/10(0) Plate Type(s): WAVE	<b>Defl/CSI Criteria</b> PP Deflection in loc L/defl L/# VERT(LL): 0.142 N 999 360 VERT(CL): 0.280 N 857 240 HORZ(LL): -0.109 F - - HORZ(TL): 0.215 F - - Creep Factor: 2.0 Max TC CSI: 0.986 Max BC CSI: 0.736 Max Web CSI: 0.888 VIEW Ver: 24.02.00D.0114.10	<b>Maximum Reactions (lbs)</b> <table border="1"> <thead> <tr> <th rowspan="2">Loc</th> <th colspan="3">Gravity</th> <th colspan="3">Non-Gravity</th> </tr> <tr> <th>R+</th> <th>/R-</th> <th>/Rh</th> <th>/Rw</th> <th>/U</th> <th>/RL</th> </tr> </thead> <tbody> <tr> <td>S</td> <td>4210</td> <td>-</td> <td>-</td> <td>/529</td> <td>/597</td> <td>/299</td> </tr> <tr> <td>AG</td> <td>2230</td> <td>-</td> <td>-</td> <td>/593</td> <td>/252</td> <td>-</td> </tr> </tbody> </table> Wind reactions based on MWFRS S Brg Wid = 3.5 Min Req = 1.7 (Truss) AG Brg Wid = 5.5 Min Req = 1.5 (Truss) Bearings S & AG are a rigid surface. Members not listed have forces less than 375# <b>Maximum Top Chord Forces Per Ply (lbs)</b> <table border="1"> <thead> <tr> <th>Chords</th> <th>Tens.Comp.</th> <th>Chords</th> <th>Tens. Comp.</th> </tr> </thead> <tbody> <tr> <td>F - G</td> <td>714 -8</td> <td>E - F</td> <td>213 -876</td> </tr> <tr> <td>B - C</td> <td>321 -1371</td> <td>G - H</td> <td>690 -27</td> </tr> <tr> <td>C - D</td> <td>321 -1371</td> <td>H - I</td> <td>83 -1077</td> </tr> <tr> <td>D - E</td> <td>355 -1537</td> <td>I - J</td> <td>167 -1296</td> </tr> </tbody> </table>	Loc	Gravity			Non-Gravity			R+	/R-	/Rh	/Rw	/U	/RL	S	4210	-	-	/529	/597	/299	AG	2230	-	-	/593	/252	-	Chords	Tens.Comp.	Chords	Tens. Comp.	F - G	714 -8	E - F	213 -876	B - C	321 -1371	G - H	690 -27	C - D	321 -1371	H - I	83 -1077	D - E	355 -1537	I - J	167 -1296
Loc	Gravity			Non-Gravity																																															
	R+	/R-	/Rh	/Rw	/U	/RL																																													
S	4210	-	-	/529	/597	/299																																													
AG	2230	-	-	/593	/252	-																																													
Chords	Tens.Comp.	Chords	Tens. Comp.																																																
F - G	714 -8	E - F	213 -876																																																
B - C	321 -1371	G - H	690 -27																																																
C - D	321 -1371	H - I	83 -1077																																																
D - E	355 -1537	I - J	167 -1296																																																

**Lumber**  
 Top chord: 2x4 SP #2; T3,T5 2x4 SP M-31;  
 Bot chord: 2x4 SP M-31; B2 2x6 SP #2;  
 B3 2x4 SP #2;  
 Webs: 2x4 SP #3; W1 2x4 SP M-31; W2 2x4 SP #2;

**Bracing**  
 (a) Continuous lateral restraint equally spaced on member.

**Nailnote**  
 Nail Schedule: 0.128"x3", min. nails  
 Top Chord: 1 Row @ 4.50" o.c.  
 Bot Chord: 1 Row @ 12.00" o.c.  
 Webs : 1 Row @ 4" o.c.  
 Use equal spacing between rows and stagger nails in each row to avoid splitting.

**Special Loads**  
 -----(Lumber Dur.Fac.=1.00 / Plate Dur.Fac.=1.00)  
 TC: From 68 plf at 0.00 to 68 plf at 22.13  
 PLT: From 361 plf at 0.00 to 361 plf at 8.88  
 PLT: From 20 plf at 10.32 to 20 plf at 12.80  
 PLT: From 20 plf at 0.58 to 20 plf at 2.26  
 PLT: From 100 plf at 2.26 to 100 plf at 12.51  
 BC: From 20 plf at 0.00 to 20 plf at 20.08  
 BC: From 6 plf at 20.08 to 6 plf at 22.13  
 BC: 163 lb Conc. Load at 2.26  
 BC: 121 lb Conc. Load at 12.51

**Purlins**  
 Collar-tie braced with continuous lateral bracing at 24" oc. or rigid ceiling.

**Plating Notes**  
 All plates are 3X4 except as noted.  
 (\*\*) 1 plate(s) require special positioning. Refer to scaled plate plot details for special positioning requirements.

**Wind**  
 Wind loads based on MWFRS with additional C&C member design.  
 Left end vertical not exposed to wind pressure.  
 Wind loading based on both gable and hip roof types.

**Maximum Bot Chord Forces Per Ply (lbs)**

Chords	Tens.Comp.	Chords	Tens. Comp.
S - R	418 -881	O - N	1754 -132
R - Q	567 -112	N - M	1975 -396
Q - P	616 -100	M - L	1933 -385
P - O	1482 -53	L - J	855 -106

**Maximum Web Forces Per Ply (lbs)**

Webs	Tens.Comp.	Webs	Tens. Comp.
S - U	381 -2482	B - Z	1358 -310
S - V	921 -172	R - Y	158 -1382
T - U	384 -2492	Y - Q	407 -49
T - V	2574 -419	C - Z	106 -492
T - X	134 -764	Z -AB	1025 -294
V - X	305 -1453	P -AC	218 -1032
V - Y	1297 -268	AB - E	908 -194
W - R	770 -60	AC-AE	95 -906
X - B	244 -1135	AE-AF	266 -1140
X - Z	108 -607	AF - L	427 -1106

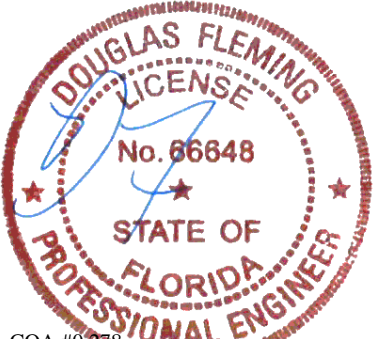

COA #0 278  
 Florida Certificate of Product Approval #FL1999  
 02/25/2026

**\*\*WARNING\*\* READ AND FOLLOW ALL NOTES ON THIS DRAWING!**  
**\*\*IMPORTANT\*\* FURNISH THIS DRAWING TO ALL CONTRACTORS INCLUDING THE INSTALLERS**  
 Trusses require extreme care in fabricating, handling, shipping, installing and bracing. Refer to and follow the latest edition of BCSI (Building Component Safety Information, by TPI and SBCA) for safety practices prior to performing these functions. Installers shall provide temporary bracing per BCSI. Unless noted otherwise, top chord shall have properly attached structural sheathing and bottom chord shall have a properly attached rigid ceiling. Locations shown for permanent lateral restraint of webs shall have continuous lateral restraint (CLR), installed with diagonal bracing installed on the CLR per BCSI sections B3, B7, or B10, as applicable. Apply plates to each face of truss and position as shown above and on the Joint Details, unless noted otherwise. Refer to drawings 160A-Z for standard plate positions. Refer to job's General Notes page for additional information.  
 Alpine, a division of ITW Building Components Group Inc. shall not be responsible for any deviation from this drawing, any failure to build the truss in conformance with ANSI/TPI 1, or for handling, shipping, installation and bracing of trusses. A seal on this drawing or cover page listing this drawing, indicates acceptance of professional engineering responsibility solely for the design shown. The suitability and use of this drawing for any structure is the responsibility of the Building Designer per ANSI/TPI 1 Sec.2.  
 For more information see these web sites: Alpine: alpineitw.com; TPI: tpinst.org; SBCA: sbccomponents.com; ICC: iccsafe.org; AWC: awc.org



SEQN: 728264	ATIC	Ply: 2	Job Number: 26-3388d	Cust: R215 JRef: 1YHX2150002 T7
FROM: RFG		Qty: 1	JOHNSON	DrwNo: 056.26.0835.45890
Page 2 of 2			Truss Label: C3	JB / DF 02/25/2026

**Additional Notes**

The overall height of this truss excluding overhang is 10-8-0.

WIND LOAD CASE MODIFIED!

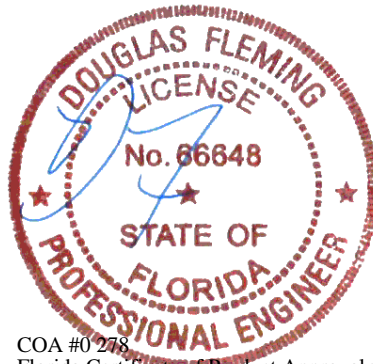

COA #0278  
 Florida Certificate of Product Approval #FL1999  
 02/25/2026

**\*\*WARNING\*\* READ AND FOLLOW ALL NOTES ON THIS DRAWING!**  
**\*\*IMPORTANT\*\* FURNISH THIS DRAWING TO ALL CONTRACTORS INCLUDING THE INSTALLERS**  
 Trusses require extreme care in fabricating, handling, shipping, installing and bracing. Refer to and follow the latest edition of BCSI (Building Component Safety Information, by TPI and SBCA) for safety practices prior to performing these functions. Installers shall provide temporary bracing per BCSI. Unless noted otherwise, top chord shall have properly attached structural sheathing and bottom chord shall have a properly attached rigid ceiling. Locations shown for permanent lateral restraint of webs shall have continuous lateral restraint (CLR), installed with diagonal bracing installed on the CLR per BCSI sections B3, B7, or B10, as applicable. Apply plates to each face of truss and position as shown above and on the Joint Details, unless noted otherwise. Refer to drawings 160A-Z for standard plate positions. Refer to job's General Notes page for additional information.  
 Alpine, a division of ITW Building Components Group Inc. shall not be responsible for any deviation from this drawing, any failure to build the truss in conformance with ANSI/TPI 1, or for handling, shipping, installation and bracing of trusses. A seal on this drawing or cover page listing this drawing, indicates acceptance of professional engineering responsibility solely for the design shown. The suitability and use of this drawing for any structure is the responsibility of the Building Designer per ANSI/TPI 1 Sec.2.  
 For more information see these web sites: Alpine: [alpineitw.com](http://alpineitw.com); TPI: [tpinst.org](http://tpinst.org); SBCA: [sbcacomponents.com](http://sbcacomponents.com); ICC: [iccsafe.org](http://iccsafe.org); AWC: [awc.org](http://awc.org)



2 Complete Trusses Required

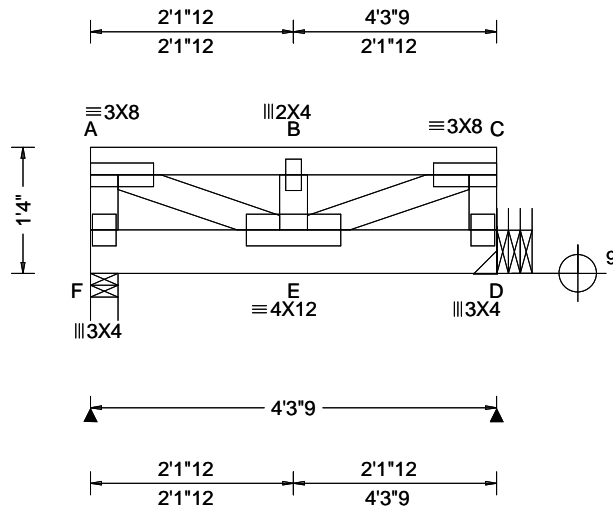

<b>Loading Criteria</b> (psf)	<b>Wind Criteria</b>	<b>Snow Criteria</b> (Pg,Pf in PSF)	<b>Defl/CSI Criteria</b>	<b>▲ Maximum Reactions (lbs)</b>
TCLL: 40.00 TCDL: 10.00 BCLL: 0.00 BCDL: 5.00 Des Ld: 55.00 NCBCLL: 10.00 Soffit: 2.00 Load Duration: 1.00 Spacing: 24.0 "	Wind Std: NA Speed: NA mph Enclosure: NA Category: NA EXP: NA Kzt: NA Mean Height: NA ft TCDL: NA psf BCDL: NA psf MWFRS Parallel Dist: NA C&C Dist a: NA Loc. from endwall: NA I: NA GCpi: NA Wind Duration: NA	Pg: NA Ct: NA CAT: NA Pf: NA Ce: NA Lu: NA Cs: NA Snow Duration: NA  Building Code: FBC 8th Ed. 2023 Res. TPI Std: 2014 Rep Fac: Varies by Ld Case FT/RT:20(0)/10(0) Plate Type(s): WAVE	PP Deflection in loc L/defl L/# VERT(LL): 0.018 B 999 480 VERT(CL): 0.033 B 999 360 HORZ(LL): 0.003 A - - HORZ(TL): 0.005 A - - Creep Factor: 2.0 Max TC CSI: 0.519 Max BC CSI: 0.236 Max Web CSI: 0.796  VIEW Ver: 24.02.00D.0114.10	Gravity Non-Gravity Loc R+ /R- /Rh /Rw /U /RL F 2715 /- /- /- /- /- D 2992 /- /- /- /- /- F Brg Wid = 3.5 Min Req = 1.5 (Truss) D Brg Wid = - Min Req = - Bearing F is a rigid surface. Members not listed have forces less than 375# <b>Maximum Top Chord Forces Per Ply (lbs)</b> Chords Tens.Comp. Chords Tens. Comp. A - B 0 - 1551 B - C 0 - 1551

**Lumber**

Top chord: 2x4 SP #2;  
Bot chord: 2x6 SP 2400f-2.0E;  
Webs: 2x4 SP #3;

**Nailnote**

Nail Schedule: 0.128"x3", min. nails  
Top Chord: 1 Row @ 3.25" o.c.  
Bot Chord: 2 Rows @ 4.50" o.c. (Each Row)  
Webs : 1 Row @ 4" o.c.  
Use equal spacing between rows and stagger nails in each row to avoid splitting.

**Special Loads**

----- (Lumber Dur.Fac.=1.00 / Plate Dur.Fac.=1.00)  
TC: From 763 plf at 0.00 to 763 plf at 4.30  
BC: From 5 plf at 0.00 to 5 plf at 4.30  
BC: 1203 lb Conc. Load at 1.40, 3.40

**Purlins**

The TC of this truss shall be braced with attached spans at 24" oc in lieu of structural sheathing.

**Additional Notes**

Truss must be installed as shown with top chord up.  
The overall height of this truss excluding overhang is 1'-4.0.

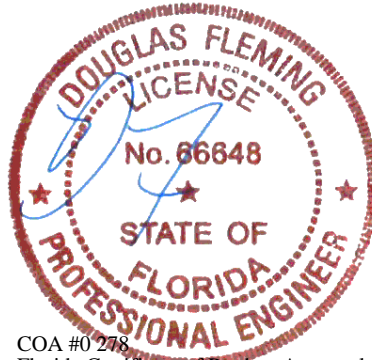

COA #0 278  
Florida Certificate of Product Approval #FL1999  
02/25/2026

**\*\*WARNING\*\* READ AND FOLLOW ALL NOTES ON THIS DRAWING!**  
**\*\*IMPORTANT\*\* FURNISH THIS DRAWING TO ALL CONTRACTORS INCLUDING THE INSTALLERS**  
Trusses require extreme care in fabricating, handling, shipping, installing and bracing. Refer to and follow the latest edition of BCSI (Building Component Safety Information, by TPI and SBCA) for safety practices prior to performing these functions. Installers shall provide temporary bracing per BCSI. Unless noted otherwise, top chord shall have properly attached structural sheathing and bottom chord shall have a properly attached rigid ceiling. Locations shown for permanent lateral restraint of webs shall have continuous lateral restraint (CLR), installed with diagonal bracing installed on the CLR per BCSI sections B3, B7, or B10, as applicable. Apply plates to each face of truss and position as shown above and on the Joint Details, unless noted otherwise. Refer to drawings 160A-Z for standard plate positions. Refer to job's General Notes page for additional information.  
Alpine, a division of ITW Building Components Group Inc. shall not be responsible for any deviation from this drawing, any failure to build the truss in conformance with ANSI/TPI 1, or for handling, shipping, installation and bracing of trusses. A seal on this drawing or cover page listing this drawing, indicates acceptance of professional engineering responsibility solely for the design shown. The suitability and use of this drawing for any structure is the responsibility of the Building Designer per ANSI/TPI 1 Sec.2.  
For more information see these web sites: Alpine: alpineitw.com; TPI: tpinst.org; SBCA: sbcacomponents.com; ICC: iccsafe.org; AWC: awc.org



SEQN: 728230	FLAT	Ply: 2	Job Number: 26-3388d	Cust: R215	JRef: 1YHX2150002	T17
FROM: RFG		Qty: 1	JOHNSON	DrwNo: 056.26.0835.38093		
Page 2 of 2			Truss Label: FG1	JB / DF		02/25/2026

**Hangers / Ties**

Simpson Construction Hardware is specified based on the most current information provided by Simpson Strong-Tie. Please refer to the most recent Simpson Strong-Tie catalog for additional information.

Recommended connection based on manufacturer tested capacities and calculations. Conditions may exist that require different connections than indicated. Refer to manufacturer publication for additional information. Additional connection required to evenly distribute hanger reaction throughout all plies of supporting girder.

Hanger specified assumes connection to supporting chord is located a minimum of five times the depth of the supporting chord from any unsupported end, unless unsupported chord end has 85% plating coverage.

Bearing at location  $x=4'0''9$  uses the following support conditions: 4'0''9

Bearing D (4'0''9, 9') HGUS26-2

Supporting Member: (3)2x6 SP 2400f-2.0E

(20) 0.148"x3" nails into supporting member,

(6) 0.148"x3" nails into supported member.

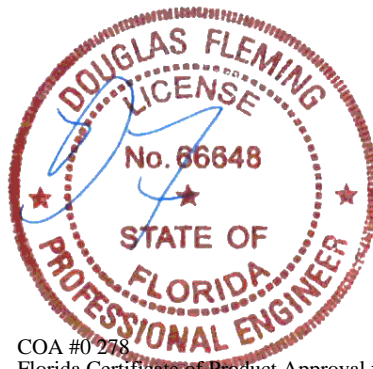

COA #0278  
 Florida Certificate of Product Approval #FL1999  
 02/25/2026

**\*\*WARNING\*\* READ AND FOLLOW ALL NOTES ON THIS DRAWING!**  
**\*\*IMPORTANT\*\* FURNISH THIS DRAWING TO ALL CONTRACTORS INCLUDING THE INSTALLERS**  
 Trusses require extreme care in fabricating, handling, shipping, installing and bracing. Refer to and follow the latest edition of BCSI (Building Component Safety Information, by TPI and SBCA) for safety practices prior to performing these functions. Installers shall provide temporary bracing per BCSI. Unless noted otherwise, top chord shall have properly attached structural sheathing and bottom chord shall have a properly attached rigid ceiling. Locations shown for permanent lateral restraint of webs shall have continuous lateral restraint (CLR), installed with diagonal bracing installed on the CLR per BCSI sections B3, B7, or B10, as applicable. Apply plates to each face of truss and position as shown above and on the Joint Details, unless noted otherwise. Refer to drawings 160A-Z for standard plate positions. Refer to job's General Notes page for additional information.  
 Alpine, a division of ITW Building Components Group Inc. shall not be responsible for any deviation from this drawing, any failure to build the truss in conformance with ANSI/TPI 1, or for handling, shipping, installation and bracing of trusses. A seal on this drawing or cover page listing this drawing, indicates acceptance of professional engineering responsibility solely for the design shown. The suitability and use of this drawing for any structure is the responsibility of the Building Designer per ANSI/TPI 1 Sec.2.  
 For more information see these web sites: Alpine: [alpineitw.com](http://alpineitw.com); TPI: [tpinst.org](http://tpinst.org); SBCA: [sbcacomponents.com](http://sbcacomponents.com); ICC: [iccsafe.org](http://iccsafe.org); AWC: [awc.org](http://awc.org)



2 Complete Trusses Required

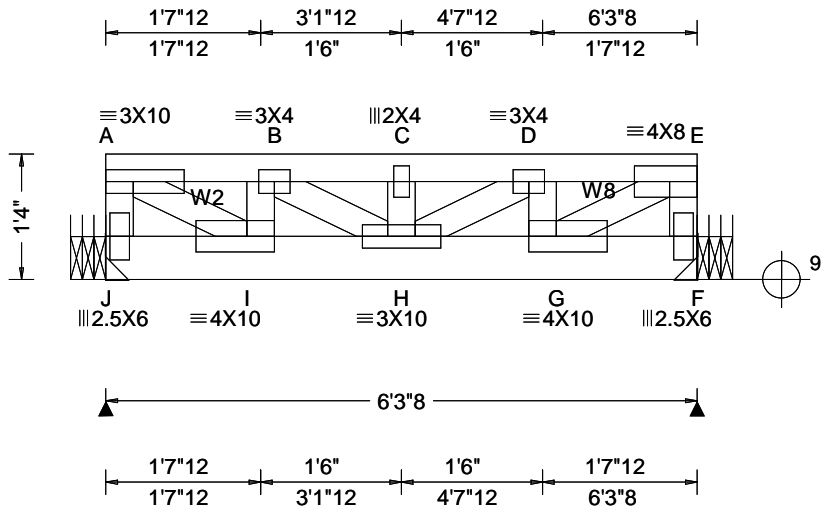

<b>Loading Criteria (psf)</b> TCLL: 40.00 TCCL: 10.00 BCLL: 0.00 BCDL: 5.00 Des Ld: 55.00 NCBCLL: 10.00 Soffit: 2.00 Load Duration: 1.00 Spacing: 24.0 "	<b>Wind Criteria</b> Wind Std: NA Speed: NA mph Enclosure: NA Category: NA EXP: NA Kzt: NA Mean Height: NA ft TCCL: NA psf BCDL: NA psf MWFRS Parallel Dist: NA C&C Dist a: NA Loc. from endwall: NA I: NA GCpi: NA Wind Duration: NA	<b>Snow Criteria (Pg,Pf in PSF)</b> Pg: NA Ct: NA CAT: NA Pf: NA Ce: NA Lu: NA Cs: NA Snow Duration: NA Building Code: FBC 8th Ed. 2023 Res. TPI Std: 2014 Rep Fac: Varies by Ld Case FT/RT:20(0)/10(0) Plate Type(s): WAVE	<b>Defl/CSI Criteria</b> PP Deflection in loc L/defl L/# VERT(LL): 0.047 C 999 480 VERT(CL): 0.061 C 999 360 HORZ(LL): 0.013 A - - HORZ(TL): 0.016 A - - Creep Factor: 2.0 Max TC CSI: 0.383 Max BC CSI: 0.400 Max Web CSI: 0.752 VIEW Ver: 24.02.00D.0114.10	<b>▲ Maximum Reactions (lbs)</b> Gravity Non-Gravity Loc R+ / R- / Rh / Rw / U / RL J 4227 /- /- /- /- /- F 3523 /- /- /- /- /- J Brg Wid = - Min Req = - F Brg Wid = - Min Req = - Members not listed have forces less than 375# <b>Maximum Top Chord Forces Per Ply (lbs)</b> Chords Tens.Comp. Chords Tens. Comp. A - B 0 - 2244 C - D 0 - 3105 B - C 0 - 3105 D - E 0 - 2259					
				<b>Maximum Bot Chord Forces Per Ply (lbs)</b> Chords Tens.Comp. Chords Tens. Comp. I - H 2512 0 H - G 2518 0 <b>Maximum Web Forces Per Ply (lbs)</b> Webs Tens.Comp. Webs Tens. Comp. A - J 0 - 1649 H - D 719 0 A - I 2643 0 D - G 0 - 890 I - B 0 - 920 G - E 2664 0 B - H 726 0 E - F 0 - 1565					

**Lumber**

Top chord: 2x4 SP #2;  
 Bot chord: 2x6 SP 2400f-2.0E;  
 Webs: 2x4 SP #3; W2,W8 2x4 SP #2;

**Nailnote**

Nail Schedule: 0.128"x3", min. nails  
 Top Chord: 1 Row @ 4.75" o.c.  
 Bot Chord: 2 Rows @ 3.50" o.c. (Each Row)  
 Webs : 1 Row @ 4" o.c.  
 Use equal spacing between rows and stagger nails in each row to avoid splitting.

**Special Loads**

----- (Lumber Dur.Fac.=1.00 / Plate Dur.Fac.=1.00)  
 TC: From 521 plf at 0.00 to 521 plf at 5.77  
 TC: From 160 plf at 5.77 to 160 plf at 5.95  
 TC: From 50 plf at 5.95 to 50 plf at 6.29  
 BC: From 5 plf at 0.00 to 5 plf at 6.29  
 BC: 1556 lb Conc. Load at 0.81, 2.81, 4.81

**Purlins**

The TC of this truss shall be braced with attached spans at 24" oc in lieu of structural sheathing.

**Additional Notes**

Truss must be installed as shown with top chord up.  
 The overall height of this truss excluding overhang is 1'-4".

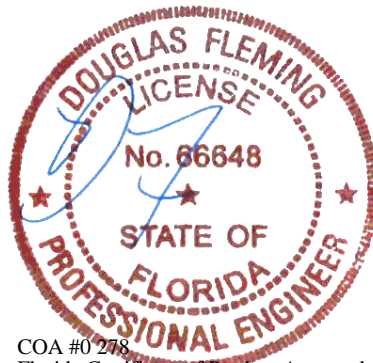

COA #0 278  
 Florida Certificate of Product Approval #FL1999  
 02/25/2026

**\*\*WARNING\*\* READ AND FOLLOW ALL NOTES ON THIS DRAWING!**  
**\*\*IMPORTANT\*\* FURNISH THIS DRAWING TO ALL CONTRACTORS INCLUDING THE INSTALLERS**  
 Trusses require extreme care in fabricating, handling, shipping, installing and bracing. Refer to and follow the latest edition of BCSI (Building Component Safety Information, by TPI and SBCA) for safety practices prior to performing these functions. Installers shall provide temporary bracing per BCSI. Unless noted otherwise, top chord shall have properly attached structural sheathing and bottom chord shall have a properly attached rigid ceiling. Locations shown for permanent lateral restraint of webs shall have continuous lateral restraint (CLR), installed with diagonal bracing installed on the CLR per BCSI sections B3, B7, or B10, as applicable. Apply plates to each face of truss and position as shown above and on the Joint Details, unless noted otherwise. Refer to drawings 160A-Z for standard plate positions. Refer to job's General Notes page for additional information.  
 Alpine, a division of ITW Building Components Group Inc. shall not be responsible for any deviation from this drawing, any failure to build the truss in conformance with ANSI/TPI 1, or for handling, shipping, installation and bracing of trusses. A seal on this drawing or cover page listing this drawing, indicates acceptance of professional engineering responsibility solely for the design shown. The suitability and use of this drawing for any structure is the responsibility of the Building Designer per ANSI/TPI 1 Sec.2.  
 For more information see these web sites: Alpine: alpineitw.com; TPI: tpinst.org; SBCA: sbcacomponents.com; ICC: iccsafe.org; AWC: awc.org



2 Complete Trusses Required

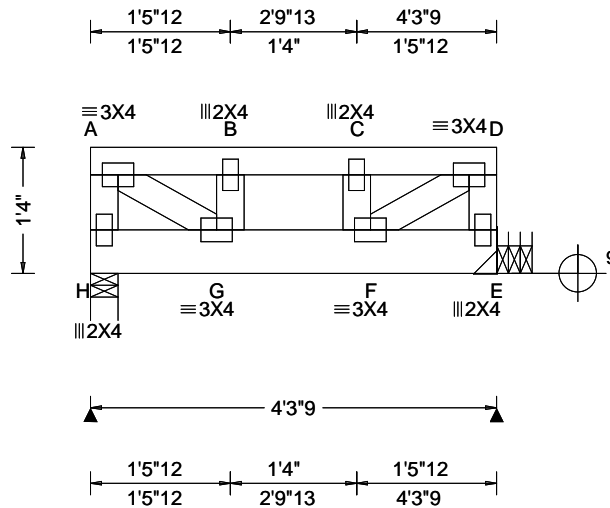

<b>Loading Criteria (psf)</b> TCLL: 40.00 TCDL: 10.00 BCCL: 0.00 BCDL: 5.00 Des Ld: 55.00 NCBCLL: 10.00 Soffit: 2.00 Load Duration: 1.00 Spacing: 24.0 "	<b>Wind Criteria</b> Wind Std: NA Speed: NA mph Enclosure: NA Category: NA EXP: NA Kzt: NA Mean Height: NA ft TCDL: NA psf BCDL: NA psf MWFRS Parallel Dist: NA C&C Dist a: NA Loc. from endwall: NA I: NA GCpi: NA Wind Duration: NA	<b>Snow Criteria (Pg,Pf in PSF)</b> Pg: NA Ct: NA CAT: NA Pf: NA Ce: NA Lu: NA Cs: NA Snow Duration: NA  <b>Building Code:</b> FBC 8th Ed. 2023 Res. TPI Std: 2014 Rep Fac: Varies by Ld Case FT/RT:20(0)/10(0) Plate Type(s): WAVE	<b>Defl/CSI Criteria</b> PP Deflection in loc L/defl L/# VERT(LL): 0.004 B 999 480 VERT(CL): 0.005 B 999 360 HORZ(LL): 0.001 A - - HORZ(TL): 0.002 A - - Creep Factor: 2.0 Max TC CSI: 0.036 Max BC CSI: 0.062 Max Web CSI: 0.202  VIEW Ver: 24.02.00D.0114.10	<b>▲ Maximum Reactions (lbs)</b> <table style="width:100%; border-collapse: collapse;"> <thead> <tr> <th rowspan="2">Loc</th> <th colspan="3">Gravity</th> <th colspan="3">Non-Gravity</th> </tr> <tr> <th>R+</th> <th>/R-</th> <th>/Rh</th> <th>/Rw</th> <th>/U</th> <th>/RL</th> </tr> </thead> <tbody> <tr> <td>H</td> <td>630</td> <td>-</td> <td>-</td> <td>-</td> <td>-</td> <td>-</td> </tr> <tr> <td>E</td> <td>764</td> <td>-</td> <td>-</td> <td>-</td> <td>-</td> <td>-</td> </tr> <tr> <td colspan="7">H Brg Wid = 3.5 Min Req = 1.5 (Truss)</td> </tr> <tr> <td colspan="7">E Brg Wid = - Min Req = -</td> </tr> <tr> <td colspan="7">Bearing H is a rigid surface.</td> </tr> <tr> <td colspan="7">Members not listed have forces less than 375#</td> </tr> <tr> <td colspan="7"><b>Maximum Web Forces Per Ply (lbs)</b></td> </tr> <tr> <th colspan="2">Webs</th> <th colspan="2">Tens.Comp.</th> <th colspan="2">Webs</th> <th colspan="2">Tens. Comp.</th> </tr> <tr> <td colspan="2">A - G</td> <td colspan="2">425</td> <td colspan="2">0</td> <td colspan="2">F - D 423 0</td> </tr> </tbody> </table>	Loc	Gravity			Non-Gravity			R+	/R-	/Rh	/Rw	/U	/RL	H	630	-	-	-	-	-	E	764	-	-	-	-	-	H Brg Wid = 3.5 Min Req = 1.5 (Truss)							E Brg Wid = - Min Req = -							Bearing H is a rigid surface.							Members not listed have forces less than 375#							<b>Maximum Web Forces Per Ply (lbs)</b>							Webs		Tens.Comp.		Webs		Tens. Comp.		A - G		425		0		F - D 423 0	
Loc	Gravity			Non-Gravity																																																																														
	R+	/R-	/Rh	/Rw	/U	/RL																																																																												
H	630	-	-	-	-	-																																																																												
E	764	-	-	-	-	-																																																																												
H Brg Wid = 3.5 Min Req = 1.5 (Truss)																																																																																		
E Brg Wid = - Min Req = -																																																																																		
Bearing H is a rigid surface.																																																																																		
Members not listed have forces less than 375#																																																																																		
<b>Maximum Web Forces Per Ply (lbs)</b>																																																																																		
Webs		Tens.Comp.		Webs		Tens. Comp.																																																																												
A - G		425		0		F - D 423 0																																																																												

**Lumber**

Top chord: 2x4 SP #2;  
 Bot chord: 2x6 SP 2400f-2.0E;  
 Webs: 2x4 SP #3;

**Nailnote**

Nail Schedule: 0.128"x3", min. nails  
 Top Chord: 1 Row @ 12.00" o.c.  
 Bot Chord: 1 Row @ 4.50" o.c.  
 Webs : 1 Row @ 4" o.c.  
 Use equal spacing between rows and stagger nails in each row to avoid splitting.

**Special Loads**

----- (Lumber Dur.Fac.=1.00 / Plate Dur.Fac.=1.00)  
 TC: From 50 plf at 0.00 to 50 plf at 4.30  
 BC: From 5 plf at 0.00 to 5 plf at 4.30  
 BC: 579 lb Conc. Load at 1.40, 3.40

**Purlins**

The TC of this truss shall be braced with attached spans at 24" oc in lieu of structural sheathing.

**Additional Notes**

Truss must be installed as shown with top chord up.  
 The overall height of this truss excluding overhang is 1-4-0.

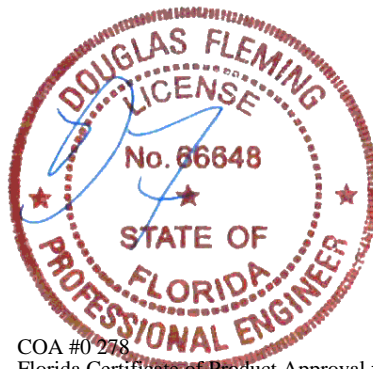

COA #0 278  
 Florida Certificate of Product Approval #FL1999  
 02/25/2026

**\*\*WARNING\*\* READ AND FOLLOW ALL NOTES ON THIS DRAWING!**  
**\*\*IMPORTANT\*\* FURNISH THIS DRAWING TO ALL CONTRACTORS INCLUDING THE INSTALLERS**  
 Trusses require extreme care in fabricating, handling, shipping, installing and bracing. Refer to and follow the latest edition of BCSI (Building Component Safety Information, by TPI and SBCA) for safety practices prior to performing these functions. Installers shall provide temporary bracing per BCSI. Unless noted otherwise, top chord shall have properly attached structural sheathing and bottom chord shall have a properly attached rigid ceiling. Locations shown for permanent lateral restraint of webs shall have continuous lateral restraint (CLR), installed with diagonal bracing installed on the CLR per BCSI sections B3, B7, or B10, as applicable. Apply plates to each face of truss and position as shown above and on the Joint Details, unless noted otherwise. Refer to drawings 160A-Z for standard plate positions. Refer to job's General Notes page for additional information.  
 Alpine, a division of ITW Building Components Group Inc. shall not be responsible for any deviation from this drawing, any failure to build the truss in conformance with ANSI/TPI 1, or for handling, shipping, installation and bracing of trusses. A seal on this drawing or cover page listing this drawing, indicates acceptance of professional engineering responsibility solely for the design shown. The suitability and use of this drawing for any structure is the responsibility of the Building Designer per ANSI/TPI 1 Sec.2.  
 For more information see these web sites: Alpine: alpineitw.com; TPI: tpinst.org; SBCA: sbcacomponents.com; ICC: iccsafe.org; AWC: awc.org



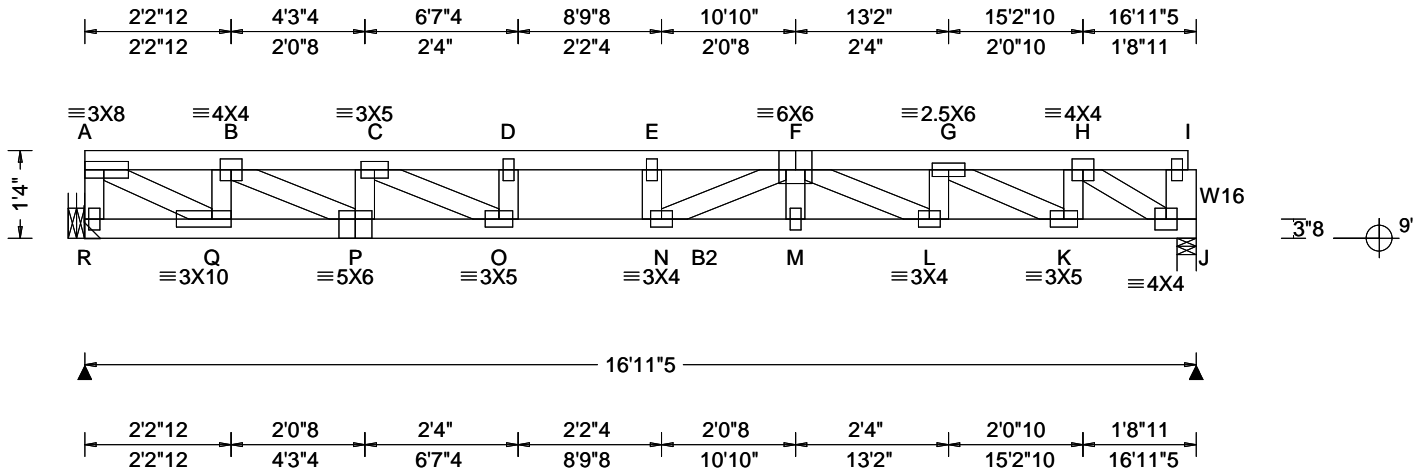

<b>Loading Criteria (psf)</b> TCLL: 40.00 TCDL: 10.00 BCLL: 0.00 BCDL: 5.00 Des Ld: 55.00 NCBCLL: 10.00 Soffit: 2.00 Load Duration: 1.00 Spacing: 24.0 "	<b>Wind Criteria</b> Wind Std: NA Speed: NA mph Enclosure: NA Category: NA EXP: NA Kzt: NA Mean Height: NA ft TCDL: NA psf BCDL: NA psf MWFRS Parallel Dist: NA C&C Dist a: NA Loc. from endwall: NA I: NA GCpi: NA Wind Duration: NA	<b>Snow Criteria (Pg,Pf in PSF)</b> Pg: NA Ct: NA CAT: NA Pf: NA Ce: NA Lu: NA Cs: NA Snow Duration: NA  Building Code: FBC 8th Ed. 2023 Res. TPI Std: 2014 Rep Fac: Yes FT/RT:20(0)/10(0) Plate Type(s): WAVE	<b>Defl/CSI Criteria</b> PP Deflection in loc L/defl L/# VERT(LL): 0.261 E 779 480 VERT(CL): 0.359 E 567 360 HORZ(LL): 0.043 A - - HORZ(TL): 0.059 A - - Creep Factor: 2.0 Max TC CSI: 0.483 Max BC CSI: 0.575 Max Web CSI: 0.805  VIEW Ver: 24.02.00D.0114.10	<b>▲ Maximum Reactions (lbs)</b> Gravity Non-Gravity Loc R+ / R- / Rh / Rw / U / RL R 932 /- /- /- /- /- J 919 /- /- /- /- /- R Brg Wid = - Min Req = - J Brg Wid = 3.5 Min Req = 1.5 (Truss) Bearing J is a rigid surface. Members not listed have forces less than 375# <b>Maximum Top Chord Forces Per Ply (lbs)</b> Chords Tens.Comp. Chords Tens. Comp. A - B 0 - 1500 E - F 0 - 3587 B - C 0 - 2721 F - G 0 - 2699 C - D 0 - 3566 G - H 0 - 1542 D - E 0 - 3606
---	--	--	---	---

**Lumber**  
Top chord: 2x4 SP #2;  
Bot chord: 2x4 SP #2; B2 2x4 SP M-31;  
Webs: 2x4 SP #3; W16 2x6 SP #2;

**Plating Notes**  
All plates are 2X4 except as noted.

**Additional Notes**  
See detail STRBRIBR1014 for bracing and bridging recommendations.  
Truss must be installed as shown with top chord up.  
The overall height of this truss excluding overhang is 1-4-0.

<b>Maximum Bot Chord Forces Per Ply (lbs)</b>			
Chords	Tens.Comp.	Chords	Tens. Comp.
Q - P	1721 0	M - L	3466 0
P - O	2875 0	L - K	2586 0
O - N	3606 0	K - J	1366 0
N - M	3466 0		

<b>Maximum Web Forces Per Ply (lbs)</b>			
Webs	Tens.Comp.	Webs	Tens. Comp.
A - R	0 -906	N - F	543 -222
A - Q	1691 0	F - L	0 -862
Q - B	0 -819	L - G	417 0
B - P	1141 0	G - K	0 -1213
P - C	0 -574	K - H	652 0
C - O	967 0	H - J	0 -1556

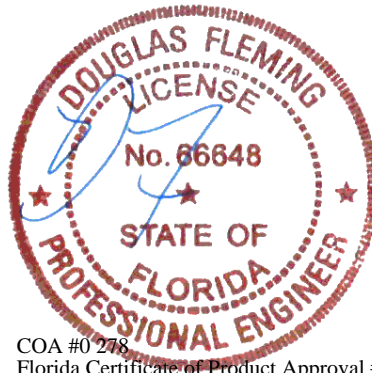

COA #0 278  
Florida Certificate of Product Approval #FL1999  
02/25/2026

**\*\*WARNING\*\* READ AND FOLLOW ALL NOTES ON THIS DRAWING!**  
**\*\*IMPORTANT\*\* FURNISH THIS DRAWING TO ALL CONTRACTORS INCLUDING THE INSTALLERS**  
Trusses require extreme care in fabricating, handling, shipping, installing and bracing. Refer to and follow the latest edition of BCSI (Building Component Safety Information, by TPI and SBCA) for safety practices prior to performing these functions. Installers shall provide temporary bracing per BCSI. Unless noted otherwise, top chord shall have properly attached structural sheathing and bottom chord shall have a properly attached rigid ceiling. Locations shown for permanent lateral restraint of webs shall have continuous lateral restraint (CLR), installed with diagonal bracing installed on the CLR per BCSI sections B3, B7, or B10, as applicable. Apply plates to each face of truss and position as shown above and on the Joint Details, unless noted otherwise. Refer to drawings 160A-Z for standard plate positions. Refer to job's General Notes page for additional information.  
Alpine, a division of ITW Building Components Group Inc. shall not be responsible for any deviation from this drawing, any failure to build the truss in conformance with ANSI/TPI 1, or for handling, shipping, installation and bracing of trusses. A seal on this drawing or cover page listing this drawing, indicates acceptance of professional engineering responsibility solely for the design shown. The suitability and use of this drawing for any structure is the responsibility of the Building Designer per ANSI/TPI 1 Sec.2.  
For more information see these web sites: Alpine: alpineitw.com; TPI: tpinst.org; SBCA: sbccomponents.com; ICC: iccsafe.org; AWC: awc.org



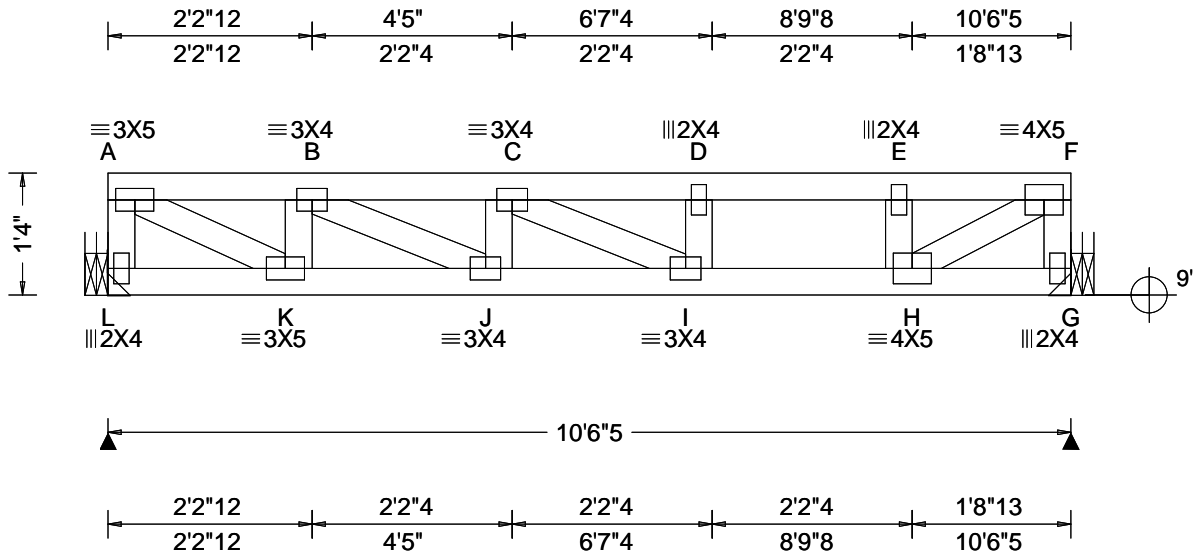

<b>Loading Criteria (psf)</b> TCLL: 40.00 TCCL: 10.00 BCCL: 0.00 BCDL: 5.00 Des Ld: 55.00 NCBCLL: 10.00 Soffit: 2.00 Load Duration: 1.00 Spacing: 24.0 "	<b>Wind Criteria</b> Wind Std: NA Speed: NA mph Enclosure: NA Category: NA EXP: NA Kzt: NA Mean Height: NA ft TCCL: NA psf BCDL: NA psf MWFRS Parallel Dist: NA C&C Dist a: NA Loc. from endwall: NA I: NA GCpi: NA Wind Duration: NA	<b>Snow Criteria (Pg,Pf in PSF)</b> Pg: NA Ct: NA CAT: NA Pf: NA Ce: NA Lu: NA Cs: NA Snow Duration: NA Building Code: FBC 8th Ed. 2023 Res. TPI Std: 2014 Rep Fac: Yes FT/RT:20(0)/10(0) Plate Type(s): WAVE	<b>Defl/CSI Criteria</b> PP Deflection in loc L/defl L/# VERT(LL): 0.089 D 999 480 VERT(CL): 0.122 D 999 360 HORZ(LL): 0.019 A - - HORZ(TL): 0.026 A - - Creep Factor: 2.0 Max TC CSI: 0.464 Max BC CSI: 0.742 Max Web CSI: 0.591 VIEW Ver: 24.02.00D.0114.10	<b>▲ Maximum Reactions (lbs)</b> <table style="width:100%; border-collapse: collapse;"> <thead> <tr> <th rowspan="2">Loc</th> <th colspan="3">Gravity</th> <th colspan="3">Non-Gravity</th> </tr> <tr> <th>R+</th> <th>/R-</th> <th>/Rh</th> <th>/Rw</th> <th>/U</th> <th>/RL</th> </tr> </thead> <tbody> <tr> <td>L</td> <td>579</td> <td>-</td> <td>-</td> <td>-</td> <td>-</td> <td>-</td> </tr> <tr> <td>G</td> <td>579</td> <td>-</td> <td>-</td> <td>-</td> <td>-</td> <td>-</td> </tr> <tr> <td>L Brg Wid</td> <td colspan="2">-</td> <td>Min Req = -</td> <td colspan="3"></td> </tr> <tr> <td>G Brg Wid</td> <td colspan="2">-</td> <td>Min Req = -</td> <td colspan="3"></td> </tr> </tbody> </table> <p>Members not listed have forces less than 375#</p> <b>Maximum Top Chord Forces Per Ply (lbs)</b> <table style="width:100%; border-collapse: collapse;"> <thead> <tr> <th>Chords</th> <th>Tens.Comp.</th> <th>Chords</th> <th>Tens. Comp.</th> </tr> </thead> <tbody> <tr> <td>A - B</td> <td>0 -854</td> <td>D - E</td> <td>0 -1127</td> </tr> <tr> <td>B - C</td> <td>0 -1403</td> <td>E - F</td> <td>0 -1065</td> </tr> <tr> <td>C - D</td> <td>0 -1129</td> <td></td> <td></td> </tr> </tbody> </table>	Loc	Gravity			Non-Gravity			R+	/R-	/Rh	/Rw	/U	/RL	L	579	-	-	-	-	-	G	579	-	-	-	-	-	L Brg Wid	-		Min Req = -				G Brg Wid	-		Min Req = -				Chords	Tens.Comp.	Chords	Tens. Comp.	A - B	0 -854	D - E	0 -1127	B - C	0 -1403	E - F	0 -1065	C - D	0 -1129		
Loc	Gravity			Non-Gravity																																																									
	R+	/R-	/Rh	/Rw	/U	/RL																																																							
L	579	-	-	-	-	-																																																							
G	579	-	-	-	-	-																																																							
L Brg Wid	-		Min Req = -																																																										
G Brg Wid	-		Min Req = -																																																										
Chords	Tens.Comp.	Chords	Tens. Comp.																																																										
A - B	0 -854	D - E	0 -1127																																																										
B - C	0 -1403	E - F	0 -1065																																																										
C - D	0 -1129																																																												

**Lumber**

Top chord: 2x4 SP #2;  
 Bot chord: 2x4 SP #2;  
 Webs: 2x4 SP #3;

**Hangers / Ties**

Simpson Construction Hardware is specified based on the most current information provided by Simpson Strong-Tie. Please refer to the most recent Simpson Strong-Tie catalog for additional information.

Recommended hanger connections are based on manufacturer tested capacities and calculations. Conditions may exist that require different connections than indicated. Refer to manufacturer publication for additional information.

Hanger specified assumes connection to supporting chord is located a minimum of five times the depth of the supporting chord from any unsupported end, unless unsupported chord end has 85% plating coverage.

Bearing G (10'3"5, 9') HUS26  
 Supporting Member: (2)2x6 SP 2400f-2.0E  
 (14) 0.148"x3" nails into supporting member,  
 (4) 0.148"x3" nails into supported member.

**Additional Notes**

Truss must be installed as shown with top chord up.  
 The overall height of this truss excluding overhang is 1-4-0.

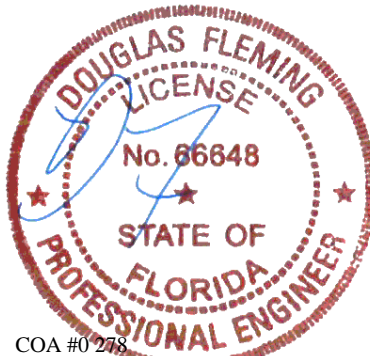

COA #0278  
 Florida Certificate of Product Approval #FL1999  
 02/25/2026

**\*\*WARNING\*\* READ AND FOLLOW ALL NOTES ON THIS DRAWING!**  
**\*\*IMPORTANT\*\* FURNISH THIS DRAWING TO ALL CONTRACTORS INCLUDING THE INSTALLERS**  
 Trusses require extreme care in fabricating, handling, shipping, installing and bracing. Refer to and follow the latest edition of BCSI (Building Component Safety Information, by TPI and SBCA) for safety practices prior to performing these functions. Installers shall provide temporary bracing per BCSI. Unless noted otherwise, top chord shall have properly attached structural sheathing and bottom chord shall have a properly attached rigid ceiling. Locations shown for permanent lateral restraint of webs shall have continuous lateral restraint (CLR), installed with diagonal bracing installed on the CLR per BCSI sections B3, B7, or B10, as applicable. Apply plates to each face of truss and position as shown above and on the Joint Details, unless noted otherwise. Refer to drawings 160A-Z for standard plate positions. Refer to job's General Notes page for additional information.  
 Alpine, a division of ITW Building Components Group Inc. shall not be responsible for any deviation from this drawing, any failure to build the truss in conformance with ANSI/TPI 1, or for handling, shipping, installation and bracing of trusses. A seal on this drawing or cover page listing this drawing, indicates acceptance of professional engineering responsibility solely for the design shown. The suitability and use of this drawing for any structure is the responsibility of the Building Designer per ANSI/TPI 1 Sec.2.  
 For more information see these web sites: Alpine: alpineitw.com; TPI: tpinst.org; SBCA: sbccomponents.com; ICC: iccsafe.org; AWC: awc.org



2 Complete Trusses Required

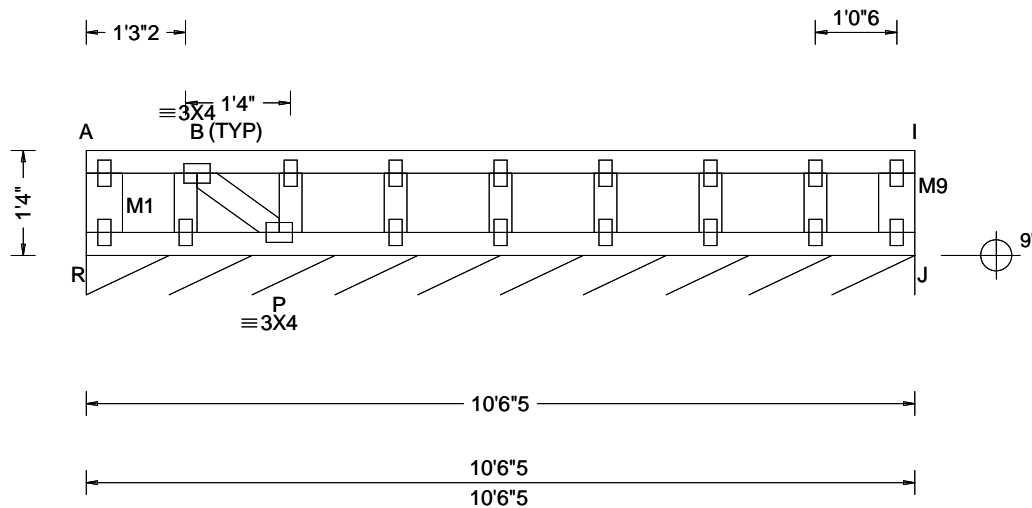

<b>Loading Criteria (psf)</b> TCCL: 40.00 TCCL: 10.00 BCCL: 0.00 BCDL: 5.00 Des Ld: 55.00 NCBCLL: 10.00 Soffit: 2.00 Load Duration: 1.00 Spacing: 24.0 "	<b>Wind Criteria</b> Wind Std: NA Speed: NA mph Enclosure: NA Category: NA EXP: NA Kzt: NA Mean Height: NA ft TCCL: NA psf BCDL: NA psf MWFRS Parallel Dist: NA C&C Dist a: NA Loc. from endwall: NA I: NA GCpi: NA Wind Duration: NA	<b>Snow Criteria (Pg,Pf in PSF)</b> Pg: NA Ct: NA CAT: NA Pf: NA Ce: NA Lu: NA Cs: NA Snow Duration: NA  Building Code: FBC 8th Ed. 2023 Res. TPI Std: 2014 Rep Fac: Yes FT/RT:20(0)/10(0) Plate Type(s): WAVE	<b>Defl/CSI Criteria</b> PP Deflection in loc L/defl L/# VERT(LL): 0.000 H 999 480 VERT(CL): 0.000 H 999 360 HORZ(LL): -0.000 R - - HORZ(TL): 0.000 R - - Creep Factor: 2.0 Max TC CSI: 0.020 Max BC CSI: 0.005 Max Web CSI: 0.016  VIEW Ver: 24.02.00D.0114.10	<b>▲ Maximum Reactions (lbs), or *=PLF</b> <table border="1"> <thead> <tr> <th colspan="3">Gravity</th> <th colspan="3">Non-Gravity</th> </tr> <tr> <th>Loc</th> <th>R+</th> <th>/R-</th> <th>/Rh</th> <th>/Rw</th> <th>/U</th> <th>/RL</th> </tr> </thead> <tbody> <tr> <td>J*</td> <td>110</td> <td>/-</td> <td>/-</td> <td>/-</td> <td>/-</td> <td>/-</td> </tr> <tr> <td>J</td> <td colspan="6">Brg Wid = 126 Min Req = -</td> </tr> </tbody> </table> Bearing R is a rigid surface. Members not listed have forces less than 375#	Gravity			Non-Gravity			Loc	R+	/R-	/Rh	/Rw	/U	/RL	J*	110	/-	/-	/-	/-	/-	J	Brg Wid = 126 Min Req = -					
				Gravity			Non-Gravity																								
Loc	R+	/R-	/Rh	/Rw	/U	/RL																									
J*	110	/-	/-	/-	/-	/-																									
J	Brg Wid = 126 Min Req = -																														
<b>Lumber</b> Top chord: 2x4 SP #2; Bot chord: 2x4 SP #2; Webs: 2x4 SP #3; M1,M9 2x6 SP #2;  <b>Nailnote</b> Nail Schedule:0.128"x3", min. nails Top Chord: 1 Row @12.00" o.c. Bot Chord: 1 Row @12.00" o.c. Webs : 1 Row @ 4" o.c. Use equal spacing between rows and stagger nails in each row to avoid splitting.  <b>Plating Notes</b> All plates are 2X4 except as noted.  <b>Purlins</b> The TC of this truss shall be braced with attached spans at 24" oc in lieu of structural sheathing.  <b>Additional Notes</b> Truss must be installed as shown with top chord up. The overall height of this truss excluding overhang is 1-4-0.  <b>Special loads</b> -----(Lumber Dur.Fac.=1.00 / Plate Dur.Fac.=1.00) TC: From 100 plf at 0.00 to 100 plf at 10.53 BC: From 10 plf at 0.00 to 10 plf at 10.53																															

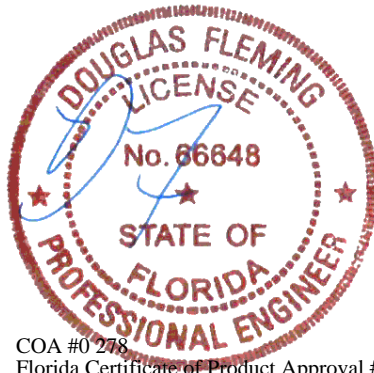

COA #0 278  
 Florida Certificate of Product Approval #FL1999  
 02/25/2026

**\*\*WARNING\*\* READ AND FOLLOW ALL NOTES ON THIS DRAWING!**  
**\*\*IMPORTANT\*\* FURNISH THIS DRAWING TO ALL CONTRACTORS INCLUDING THE INSTALLERS**  
 Trusses require extreme care in fabricating, handling, shipping, installing and bracing. Refer to and follow the latest edition of BCSI (Building Component Safety Information, by TPI and SBCA) for safety practices prior to performing these functions. Installers shall provide temporary bracing per BCSI. Unless noted otherwise, top chord shall have properly attached structural sheathing and bottom chord shall have a properly attached rigid ceiling. Locations shown for permanent lateral restraint of webs shall have continuous lateral restraint (CLR), installed with diagonal bracing installed on the CLR per BCSI sections B3, B7, or B10, as applicable. Apply plates to each face of truss and position as shown above and on the Joint Details, unless noted otherwise. Refer to drawings 160A-Z for standard plate positions. Refer to job's General Notes page for additional information.  
 Alpine, a division of ITW Building Components Group Inc. shall not be responsible for any deviation from this drawing, any failure to build the truss in conformance with ANSI/TPI 1, or for handling, shipping, installation and bracing of trusses. A seal on this drawing or cover page listing this drawing, indicates acceptance of professional engineering responsibility solely for the design shown. The suitability and use of this drawing for any structure is the responsibility of the Building Designer per ANSI/TPI 1 Sec.2.  
 For more information see these web sites: Alpine: alpineitw.com; TPI: tpinst.org; SBCA: sbcacomponents.com; ICC: iccsafe.org; AWC: awc.org

SEQN: 728228 FROM: RFG	FLAT Ply: 1 Qty: 3	Job Number: 26-3388d JOHNSON Truss Label: FL3	Cust: R215 JRef: 1YHX2150002 T8 DrwNo: 056.26.0834.53423 JB / DF 02/25/2026
---------------------------	--------------------------	---	---

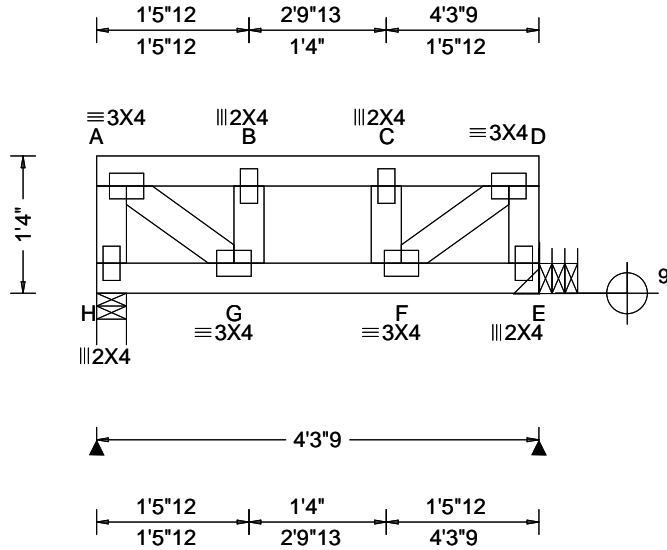

<b>Loading Criteria (psf)</b> TCCL: 40.00 TCCL: 10.00 BCLL: 0.00 BCDL: 5.00 Des Ld: 55.00 NCBCLL: 10.00 Soffit: 2.00 Load Duration: 1.00 Spacing: 24.0 "	<b>Wind Criteria</b> Wind Std: NA Speed: NA mph Enclosure: NA Category: NA EXP: NA Kzt: NA Mean Height: NA ft TCCL: NA psf BCDL: NA psf MWFRS Parallel Dist: NA C&C Dist a: NA Loc. from endwall: NA I: NA GCpi: NA Wind Duration: NA	<b>Snow Criteria (Pg,Pf in PSF)</b> Pg: NA Ct: NA CAT: NA Pf: NA Ce: NA Lu: NA Cs: NA Snow Duration: NA  Building Code: FBC 8th Ed. 2023 Res. TPI Std: 2014 Rep Fac: No FT/RT:20(0)/10(0) Plate Type(s): WAVE	<b>Defl/CSI Criteria</b> PP Deflection in loc L/defl L/# VERT(LL): 0.003 B 999 480 VERT(CL): 0.004 B 999 360 HORZ(LL): 0.001 A - - HORZ(TL): 0.002 A - - Creep Factor: 2.0 Max TC CSI: 0.063 Max BC CSI: 0.082 Max Web CSI: 0.122  VIEW Ver: 24.02.00D.0114.10	<b>▲ Maximum Reactions (lbs)</b> <table border="1"> <thead> <tr> <th rowspan="2">Loc</th> <th colspan="3">Gravity</th> <th colspan="3">Non-Gravity</th> </tr> <tr> <th>R+</th> <th>/R-</th> <th>/Rh</th> <th>/Rw</th> <th>/U</th> <th>/RL</th> </tr> </thead> <tbody> <tr> <td>H</td> <td>236</td> <td>-</td> <td>-</td> <td>-</td> <td>-</td> <td>-</td> </tr> <tr> <td>E</td> <td>236</td> <td>-</td> <td>-</td> <td>-</td> <td>-</td> <td>-</td> </tr> <tr> <td colspan="7">H Brg Wid = 3.5 Min Req = 1.5 (Truss)</td> </tr> <tr> <td colspan="7">E Brg Wid = - Min Req = -</td> </tr> </tbody> </table> Bearing H is a rigid surface. Members not listed have forces less than 375#	Loc	Gravity			Non-Gravity			R+	/R-	/Rh	/Rw	/U	/RL	H	236	-	-	-	-	-	E	236	-	-	-	-	-	H Brg Wid = 3.5 Min Req = 1.5 (Truss)							E Brg Wid = - Min Req = -						
				Loc		Gravity			Non-Gravity																																				
R+	/R-	/Rh	/Rw		/U	/RL																																							
H	236	-	-	-	-	-																																							
E	236	-	-	-	-	-																																							
H Brg Wid = 3.5 Min Req = 1.5 (Truss)																																													
E Brg Wid = - Min Req = -																																													
<b>Lumber</b> Top chord: 2x4 SP #2; Bot chord: 2x4 SP #2; Webs: 2x4 SP #3;																																													

**Additional Notes**

Truss must be installed as shown with top chord up.  
 The overall height of this truss excluding overhang is 1-4-0.

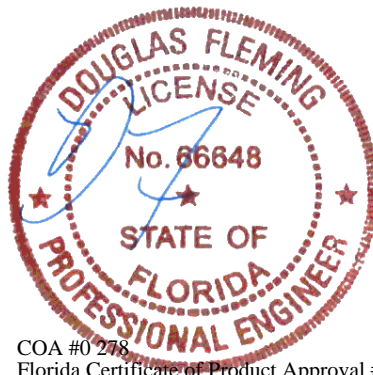

COA #0276  
 Florida Certificate of Product Approval #FL1999  
 02/25/2026

**\*\*WARNING\*\* READ AND FOLLOW ALL NOTES ON THIS DRAWING!**  
**\*\*IMPORTANT\*\* FURNISH THIS DRAWING TO ALL CONTRACTORS INCLUDING THE INSTALLERS**  
 Trusses require extreme care in fabricating, handling, shipping, installing and bracing. Refer to and follow the latest edition of BCSI (Building Component Safety Information, by TPI and SBCA) for safety practices prior to performing these functions. Installers shall provide temporary bracing per BCSI. Unless noted otherwise, top chord shall have properly attached structural sheathing and bottom chord shall have a properly attached rigid ceiling. Locations shown for permanent lateral restraint of webs shall have continuous lateral restraint (CLR), installed with diagonal bracing installed on the CLR per BCSI sections B3, B7, or B10, as applicable. Apply plates to each face of truss and position as shown above and on the Joint Details, unless noted otherwise. Refer to drawings 160A-Z for standard plate positions. Refer to job's General Notes page for additional information.  
 Alpine, a division of ITW Building Components Group Inc. shall not be responsible for any deviation from this drawing, any failure to build the truss in conformance with ANSI/TPI 1, or for handling, shipping, installation and bracing of trusses. A seal on this drawing or cover page listing this drawing, indicates acceptance of professional engineering responsibility solely for the design shown. The suitability and use of this drawing for any structure is the responsibility of the Building Designer per ANSI/TPI 1 Sec.2.  
 For more information see these web sites: Alpine: alpineitw.com; TPI: tpinst.org; SBCA: sbccomponents.com; ICC: iccsafe.org; AWC: awc.org



SEQN: 728215 FROM: RFG	MONO Ply: 1 Qty: 5	Job Number: 26-3388d JOHNSON Truss Label: M1	Cust: R 215 JRef: 1YHX2150002 T25 DrwNo: 056.26.0834.47793 JB / DF 02/25/2026
---------------------------	--------------------------	--	---

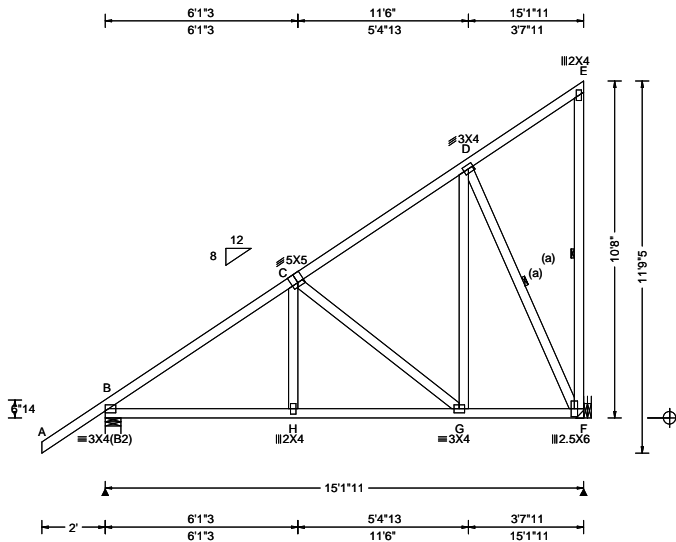

<b>Loading Criteria (psf)</b> TCCL: 20.00 TCDL: 10.00 BCCL: 0.00 BCDL: 10.00 Des Ld: 40.00 NCBCLL: 10.00 Soffit: 2.00 Load Duration: 1.25 Spacing: 24.0 "	<b>Wind Criteria</b> Wind Std: ASCE 7-22 Speed: 130 mph Enclosure: Enclosed Risk Category: II EXP: C Kzt: NA Mean Height: 15.00 ft TCDL: 5.0 psf BCDL: 5.0 psf MWFRS Parallel Dist: h/2 to h C&C Dist a: 3.00 ft Loc. from endwall: not in 9.00 ft GCp: 0.18 Wind Duration: 1.60	<b>Snow Criteria (Pg,Pf in PSF)</b> Pg: NA Ct: NA CAT: NA Pf: NA Ce: NA Lu: NA Cs: NA Snow Duration: NA Building Code: FBC 8th Ed. 2023 Res. TPI Std: 2014 Rep Fac: Yes FT/RT:20(0)/10(0) Plate Type(s): WAVE	<b>Defl/CSI Criteria</b> PP Deflection in loc L/defl L/# VERT(LL): 0.017 H 999 360 VERT(CL): 0.035 H 999 240 HORZ(LL): -0.008 E - - HORZ(TL): 0.017 E - - Creep Factor: 2.0 Max TC CSI: 0.428 Max BC CSI: 0.304 Max Web CSI: 0.357 VIEW Ver: 24.02.00D.0114.10	<b>▲ Maximum Reactions (lbs)</b> <table border="1"> <thead> <tr> <th rowspan="2">Loc</th> <th colspan="3">Gravity</th> <th colspan="3">Non-Gravity</th> </tr> <tr> <th>R+</th> <th>/R-</th> <th>/Rh</th> <th>/Rw</th> <th>/U</th> <th>/RL</th> </tr> </thead> <tbody> <tr> <td>B</td> <td>786</td> <td>-</td> <td>-</td> <td>/412</td> <td>/13</td> <td>/395</td> </tr> <tr> <td>F</td> <td>624</td> <td>-</td> <td>-</td> <td>/502</td> <td>/222</td> <td>-</td> </tr> </tbody> </table>	Loc	Gravity			Non-Gravity			R+	/R-	/Rh	/Rw	/U	/RL	B	786	-	-	/412	/13	/395	F	624	-	-	/502	/222	-
				Loc		Gravity			Non-Gravity																						
R+	/R-	/Rh	/Rw		/U	/RL																									
B	786	-	-	/412	/13	/395																									
F	624	-	-	/502	/222	-																									
Wind reactions based on MWFRS B Brg Wid = 6.0 Min Req = 1.5 (Truss) F Brg Wid = - Min Req = - Bearing B is a rigid surface. Members not listed have forces less than 375# <b>Maximum Top Chord Forces Per Ply (lbs)</b> <table border="1"> <thead> <tr> <th>Chords</th> <th>Tens.Comp.</th> <th>Chords</th> <th>Tens. Comp.</th> </tr> </thead> <tbody> <tr> <td>B - C</td> <td>0</td> <td>-788</td> <td>C - D</td> <td>0</td> <td>-401</td> </tr> </tbody> </table>				Chords	Tens.Comp.	Chords	Tens. Comp.	B - C	0	-788	C - D	0	-401																		
Chords	Tens.Comp.	Chords	Tens. Comp.																												
B - C	0	-788	C - D	0	-401																										

**Lumber**  
 Top chord: 2x4 SP #2;  
 Bot chord: 2x4 SP #2;  
 Webs: 2x4 SP #3;

**Bracing**  
 (a) Continuous lateral restraint equally spaced on member.

**Hangers / Ties**  
 Simpson Construction Hardware is specified based on the most current information provided by Simpson Strong-Tie. Please refer to the most recent Simpson Strong-Tie catalog for additional information.  
 Recommended hanger connections are based on manufacturer tested capacities and calculations. Conditions may exist that require different connections than indicated. Refer to manufacturer publication for additional information.  
 Hanger specified assumes connection to supporting chord is located a minimum of five times the depth of the supporting chord from any unsupported end, unless unsupported chord end has 85% plating coverage.  
 Bearing F (14'10" x 11, 9') HUS26  
 Supporting Member: (2)2x6 SP 2400f-2.0E  
 (14) 0.148"x3" nails into supporting member,  
 (4) 0.148"x3" nails into supported member.

**Wind**  
 Wind loads based on MWFRS with additional C&C member design.  
 Right end vertical not exposed to wind pressure.  
 Wind loading based on both gable and hip roof types.

**Additional Notes**  
 The overall height of this truss excluding overhang is 10-8-0.

**Maximum Bot Chord Forces Per Ply (lbs)**

Chords	Tens.Comp.	Chords	Tens. Comp.		
B - H	562	-263	H - G	561	-264

**Maximum Web Forces Per Ply (lbs)**

Webs	Tens.Comp.	Webs	Tens. Comp.		
C - G	196	-400	D - F	258	-566
G - D	396	-75			

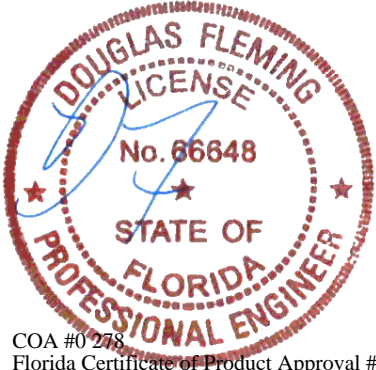

COA #0 278  
 Florida Certificate of Product Approval #FL1999  
 02/25/2026

**\*\*WARNING\*\* READ AND FOLLOW ALL NOTES ON THIS DRAWING!**  
**\*\*IMPORTANT\*\* FURNISH THIS DRAWING TO ALL CONTRACTORS INCLUDING THE INSTALLERS**  
 Trusses require extreme care in fabricating, handling, shipping, installing and bracing. Refer to and follow the latest edition of BCSI (Building Component Safety Information, by TPI and SBCA) for safety practices prior to performing these functions. Installers shall provide temporary bracing per BCSI. Unless noted otherwise, top chord shall have properly attached structural sheathing and bottom chord shall have a properly attached rigid ceiling. Locations shown for permanent lateral restraint of webs shall have continuous lateral restraint (CLR), installed with diagonal bracing installed on the CLR per BCSI sections B3, B7, or B10, as applicable. Apply plates to each face of truss and position as shown above and on the Joint Details, unless noted otherwise. Refer to drawings 160A-Z for standard plate positions. Refer to job's General Notes page for additional information.  
 Alpine, a division of ITW Building Components Group Inc. shall not be responsible for any deviation from this drawing, any failure to build the truss in conformance with ANSI/TPI 1, or for handling, shipping, installation and bracing of trusses. A seal on this drawing or cover page listing this drawing, indicates acceptance of professional engineering responsibility solely for the design shown. The suitability and use of this drawing for any structure is the responsibility of the Building Designer per ANSI/TPI 1 Sec.2.  
 For more information see these web sites: Alpine: alpineitw.com; TPI: tpinst.org; SBCA: sbccomponents.com; ICC: iccsafe.org; AWC: awc.org



2 Complete Trusses Required

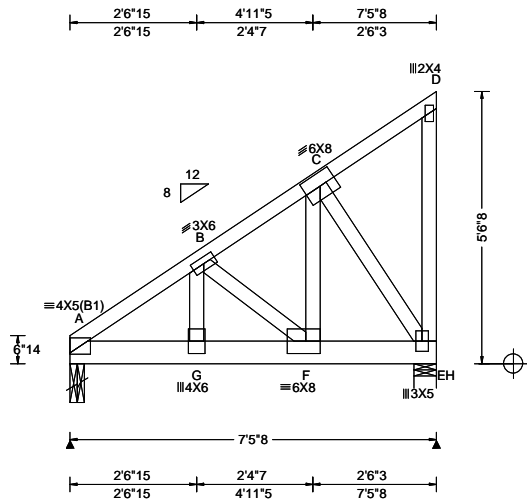

<b>Loading Criteria (psf)</b> TCLL: 20.00 TCDL: 10.00 BCLL: 0.00 BCDL: 10.00 Des Ld: 40.00 NCBCLL: 0.00 Soffit: 2.00 Load Duration: 1.25 Spacing: 24.0 "	<b>Wind Criteria</b> Wind Std: ASCE 7-22 Speed: 130 mph Enclosure: Enclosed Risk Category: II EXP: C Kzt: NA Mean Height: 15.00 ft TCDL: 5.0 psf BCDL: 5.0 psf MWFRS Parallel Dist: 0 to h/2 C&C Dist a: 3.00 ft Loc. from endwall: not in 9.00 ft GCp: 0.18 Wind Duration: 1.60	<b>Snow Criteria (Pg,Pf in PSF)</b> Pg: NA Ct: NA CAT: NA Pf: NA Ce: NA Lu: NA Cs: NA Snow Duration: NA  Building Code: FBC 8th Ed. 2023 Res. TPI Std: 2014 Rep Fac: Varies by Ld Case FT/RT:20(0)/10(0) Plate Type(s): WAVE	<b>Defl/CSI Criteria</b> PP Deflection in loc L/defl L/# VERT(LL): 0.043 G 999 360 VERT(CL): 0.044 G 999 240 HORZ(LL): -0.024 D - - HORZ(TL): 0.024 D - - Creep Factor: 2.0 Max TC CSI: 0.288 Max BC CSI: 0.355 Max Web CSI: 0.904  VIEW Ver: 24.02.00D.0114.10	<b>▲ Maximum Reactions (lbs)</b> Gravity Non-Gravity Loc R+ / R- / Rh / Rw / U / RL A 4737 /- /- /- /337 /- H 4647 /- /- /- /329 /- Wind reactions based on MWFRS A Brg Wid = 3.5 Min Req = 2.0 (Truss) H Brg Wid = 5.5 Min Req = 1.9 (Truss) Bearings A & H are a rigid surface. Members not listed have forces less than 375# <b>Maximum Top Chord Forces Per Ply (lbs)</b> Chords Tens.Comp. Chords Tens. Comp. A - B 175 - 2379 B - C 114 - 1545  <b>Maximum Bot Chord Forces Per Ply (lbs)</b> Chords Tens.Comp. Chords Tens. Comp. A - G 1933 - 138 F - E 1141 - 81 G - F 1899 - 136  <b>Maximum Web Forces Per Ply (lbs)</b> Webs Tens.Comp. Webs Tens. Comp. G - B 1006 - 51 F - C 2373 - 143 B - F 62 - 825 C - E 142 - 1993
---	---	--	--	---

**Lumber**

Top chord: 2x4 SP #2;  
Bot chord: 2x6 SP 2400f-2.0E;  
Webs: 2x4 SP #3;

**Nailnote**

Nail Schedule: 0.128"x3", min. nails  
Top Chord: 1 Row @ 12.00" o.c.  
Bot Chord: 2 Rows @ 2.50" o.c. (Each Row)  
Webs : 1 Row @ 4" o.c.  
Use equal spacing between rows and stagger nails in each row to avoid splitting.

**Special Loads**

----- (Lumber Dur.Fac.=1.25 / Plate Dur.Fac.=1.25)  
TC: From 64 plf at 0.00 to 64 plf at 7.46  
BC: From 10 plf at 0.00 to 10 plf at 7.46  
BC: 1766 lb Conc. Load at 0.70, 2.30, 3.90, 5.55  
6.39

**Wind**

Wind loads and reactions based on MWFRS.  
Right end vertical not exposed to wind pressure.  
Wind loading based on both gable and hip roof types.

**Additional Notes**

The overall height of this truss excluding overhang is 5-6-8.

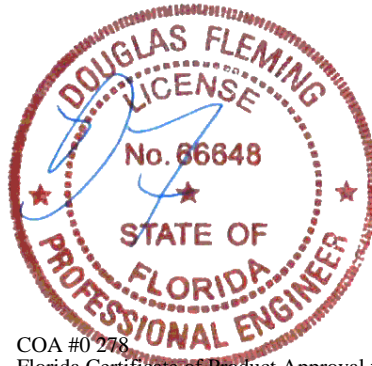

COA #0 278  
Florida Certificate of Product Approval #FL1999  
02/25/2026

**\*\*WARNING\*\* READ AND FOLLOW ALL NOTES ON THIS DRAWING!**  
**\*\*IMPORTANT\*\* FURNISH THIS DRAWING TO ALL CONTRACTORS INCLUDING THE INSTALLERS**  
Trusses require extreme care in fabricating, handling, shipping, installing and bracing. Refer to and follow the latest edition of BCSI (Building Component Safety Information, by TPI and SBCA) for safety practices prior to performing these functions. Installers shall provide temporary bracing per BCSI. Unless noted otherwise, top chord shall have properly attached structural sheathing and bottom chord shall have a properly attached rigid ceiling. Locations shown for permanent lateral restraint of webs shall have continuous lateral restraint (CLR), installed with diagonal bracing installed on the CLR per BCSI sections B3, B7, or B10, as applicable. Apply plates to each face of truss and position as shown above and on the Joint Details, unless noted otherwise. Refer to drawings 160A-Z for standard plate positions. Refer to job's General Notes page for additional information.  
Alpine, a division of ITW Building Components Group Inc. shall not be responsible for any deviation from this drawing, any failure to build the truss in conformance with ANSI/TPI 1, or for handling, shipping, installation and bracing of trusses. A seal on this drawing or cover page listing this drawing, indicates acceptance of professional engineering responsibility solely for the design shown. The suitability and use of this drawing for any structure is the responsibility of the Building Designer per ANSI/TPI 1 Sec.2.  
For more information see these web sites: Alpine: alpineitw.com; TPI: tpinst.org; SBCA: sbcacomponents.com; ICC: iccsafe.org; AWC: awc.org



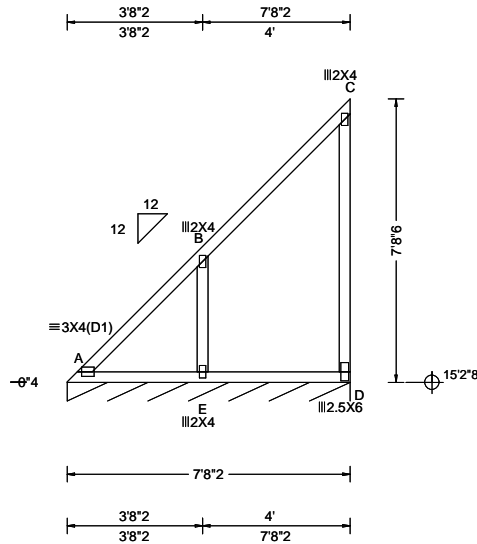

<b>Loading Criteria (psf)</b> TCLL: 20.00 TCDL: 10.00 BCLL: 0.00 BCDL: 10.00 Des Ld: 40.00 NCBCLL: 10.00 Soffit: 2.00 Load Duration: 1.25 Spacing: 24.0 "	<b>Wind Criteria</b> Wind Std: ASCE 7-22 Speed: 130 mph Enclosure: Enclosed Risk Category: II EXP: C Kzt: NA Mean Height: 19.21 ft TCDL: 5.0 psf BCDL: 5.0 psf MWFRS Parallel Dist: h/2 to h C&C Dist a: 3.00 ft Loc. from endwall: not in 9.00 ft GCp: 0.18 Wind Duration: 1.60	<b>Snow Criteria (Pg,Pf in PSF)</b> Pg: NA Ct: NA CAT: NA Pf: NA Ce: NA Lu: NA Cs: NA Snow Duration: NA  Building Code: FBC 8th Ed. 2023 Res. TPI Std: 2014 Rep Fac: Yes FT/RT:20(0)/10(0) Plate Type(s): WAVE	<b>Defl/CSI Criteria</b> PP Deflection in loc L/defl L/# VERT(LL): 0.002 A 999 360 VERT(CL): 0.005 A 999 240 HORZ(LL): 0.001 A - - HORZ(TL): 0.008 C - - Creep Factor: 2.0 Max TC CSI: 0.361 Max BC CSI: 0.168 Max Web CSI: 0.150  VIEW Ver: 24.02.00D.0114.10	<b>▲ Maximum Reactions (lbs), or *=PLF</b> Gravity Non-Gravity Loc R+ /R- /Rh /Rw /U /RL D* 88 /- /- /66 /10 /34 Wind reactions based on MWFRS D Brg Wid = 92.1 Min Req = - Bearing A is a rigid surface. Members not listed have forces less than 375# <b>Maximum Top Chord Forces Per Ply (lbs)</b> Chords Tens.Comp. A - B 198 -557  <b>Maximum Bot Chord Forces Per Ply (lbs)</b> Chords Tens.Comp. Chords Tens. Comp. A - E 485 -135 E - D 501 -143  <b>Maximum Web Forces Per Ply (lbs)</b> Webs Tens.Comp. B - E 505 -303
--	---	--	---	--

**Lumber**

Top chord: 2x4 SP #2;  
Bot chord: 2x4 SP #2;  
Webs: 2x4 SP #3;

**Wind**

Wind loads based on MWFRS with additional C&C member design.  
Right end vertical not exposed to wind pressure.  
Wind loading based on both gable and hip roof types.

**Additional Notes**

See DWGS VALTN220723 and VAL180220723 for valley details.  
The overall height of this truss excluding overhang is 7-8-6.

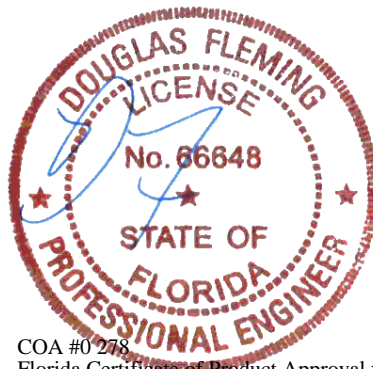

COA #0 278  
Florida Certificate of Product Approval #FL1999  
02/25/2026

**\*\*WARNING\*\* READ AND FOLLOW ALL NOTES ON THIS DRAWING!**  
**\*\*IMPORTANT\*\* FURNISH THIS DRAWING TO ALL CONTRACTORS INCLUDING THE INSTALLERS**  
Trusses require extreme care in fabricating, handling, shipping, installing and bracing. Refer to and follow the latest edition of BCSI (Building Component Safety Information, by TPI and SBCA) for safety practices prior to performing these functions. Installers shall provide temporary bracing per BCSI. Unless noted otherwise, top chord shall have properly attached structural sheathing and bottom chord shall have a properly attached rigid ceiling. Locations shown for permanent lateral restraint of webs shall have continuous lateral restraint (CLR), installed with diagonal bracing installed on the CLR per BCSI sections B3, B7, or B10, as applicable. Apply plates to each face of truss and position as shown above and on the Joint Details, unless noted otherwise. Refer to drawings 160A-Z for standard plate positions. Refer to job's General Notes page for additional information.  
Alpine, a division of ITW Building Components Group Inc. shall not be responsible for any deviation from this drawing, any failure to build the truss in conformance with ANSI/TPI 1, or for handling, shipping, installation and bracing of trusses. A seal on this drawing or cover page listing this drawing, indicates acceptance of professional engineering responsibility solely for the design shown. The suitability and use of this drawing for any structure is the responsibility of the Building Designer per ANSI/TPI 1 Sec.2.  
For more information see these web sites: Alpine: alpineitw.com; TPI: tpinst.org; SBCA: sbccomponents.com; ICC: iccsafe.org; AWC: awc.org



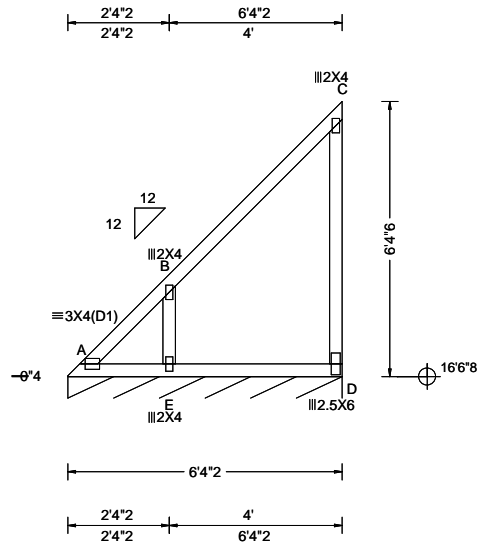

<b>Loading Criteria</b> (psf) TCLL: 20.00 TCDL: 10.00 BCLL: 0.00 BCDL: 10.00 Des Ld: 40.00 NCBCLL: 10.00 Soffit: 2.00 Load Duration: 1.25 Spacing: 24.0 "	<b>Wind Criteria</b> Wind Std: ASCE 7-22 Speed: 130 mph Enclosure: Enclosed Risk Category: II EXP: C Kzt: NA Mean Height: 19.88 ft TCDL: 5.0 psf BCDL: 5.0 psf MWFRS Parallel Dist: h/2 to h C&C Dist a: 3.00 ft Loc. from endwall: not in 9.00 ft GCp: 0.18 Wind Duration: 1.60	<b>Snow Criteria</b> (Pg,Pf in PSF) Pg: NA Ct: NA CAT: NA Pf: NA Ce: NA Lu: NA Cs: NA Snow Duration: NA  Building Code: FBC 8th Ed. 2023 Res. TPI Std: 2014 Rep Fac: Yes FT/RT:20(0)/10(0) Plate Type(s): WAVE	<b>Defl/CSI Criteria</b> PP Deflection in loc L/defl L/# VERT(LL): 0.001 C 999 360 VERT(CL): 0.001 C 999 240 HORZ(LL): 0.001 C - - HORZ(TL): 0.006 C - - Creep Factor: 2.0 Max TC CSI: 0.381 Max BC CSI: 0.131 Max Web CSI: 0.169  VIEW Ver: 24.02.00D.0114.10	<b>▲ Maximum Reactions (lbs), or *=PLF</b> Gravity Non-Gravity Loc R+ /R- /Rh /Rw /U /RL D* 88 /- /- /65 /10 /33 Wind reactions based on MWFRS D Brg Wid = 76.1 Min Req = - Bearing A is a rigid surface. Members not listed have forces less than 375# <b>Maximum Top Chord Forces Per Ply (lbs)</b> Chords Tens.Comp. A - B 177 -572  <b>Maximum Bot Chord Forces Per Ply (lbs)</b> Chords Tens.Comp. Chords Tens. Comp. A - E 440 -105 E - D 471 -116  <b>Maximum Web Forces Per Ply (lbs)</b> Webs Tens.Comp. B - E 567 -277
--	---	--	---	--

**Lumber**  
Top chord: 2x4 SP #2;  
Bot chord: 2x4 SP #2;  
Webs: 2x4 SP #3;

**Wind**  
Wind loads based on MWFRS with additional C&C member design.  
Right end vertical not exposed to wind pressure.  
Wind loading based on both gable and hip roof types.

**Additional Notes**  
See DWGS VALTN220723 and VAL180220723 for valley details.  
The overall height of this truss excluding overhang is 6-4-6.

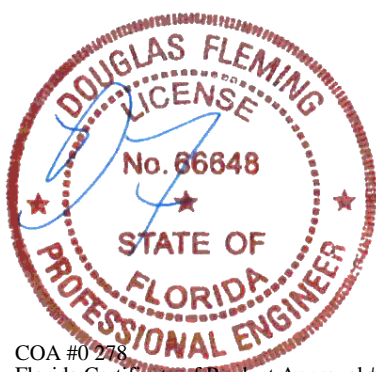

**\*\*WARNING\*\* READ AND FOLLOW ALL NOTES ON THIS DRAWING!**  
**\*\*IMPORTANT\*\* FURNISH THIS DRAWING TO ALL CONTRACTORS INCLUDING THE INSTALLERS**  
Trusses require extreme care in fabricating, handling, shipping, installing and bracing. Refer to and follow the latest edition of BCSI (Building Component Safety Information, by TPI and SBCA) for safety practices prior to performing these functions. Installers shall provide temporary bracing per BCSI. Unless noted otherwise, top chord shall have properly attached structural sheathing and bottom chord shall have a properly attached rigid ceiling. Locations shown for permanent lateral restraint of webs shall have continuous lateral restraint (CLR), installed with diagonal bracing installed on the CLR per BCSI sections B3, B7, or B10, as applicable. Apply plates to each face of truss and position as shown above and on the Joint Details, unless noted otherwise. Refer to drawings 160A-Z for standard plate positions. Refer to job's General Notes page for additional information.  
Alpine, a division of ITW Building Components Group Inc. shall not be responsible for any deviation from this drawing, any failure to build the truss in conformance with ANSI/TPI 1, or for handling, shipping, installation and bracing of trusses. A seal on this drawing or cover page listing this drawing, indicates acceptance of professional engineering responsibility solely for the design shown. The suitability and use of this drawing for any structure is the responsibility of the Building Designer per ANSI/TPI 1 Sec.2.  
For more information see these web sites: Alpine: alpineitw.com; TPI: tpinst.org; SBCA: sbccomponents.com; ICC: iccsafe.org; AWC: awc.org



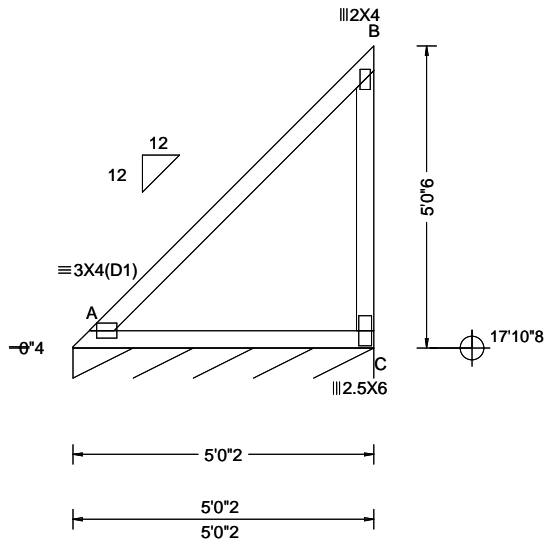

<b>Loading Criteria (psf)</b> TCLL: 20.00 TCDL: 10.00 BCLL: 0.00 BCDL: 10.00 Des Ld: 40.00 NCBCLL: 10.00 Soffit: 2.00 Load Duration: 1.25 Spacing: 24.0 "	<b>Wind Criteria</b> Wind Std: ASCE 7-22 Speed: 130 mph Enclosure: Enclosed Risk Category: II EXP: C Kzt: NA Mean Height: 20.54 ft TCDL: 5.0 psf BCDL: 5.0 psf MWFRS Parallel Dist: h/2 to h C&C Dist a: 3.00 ft Loc. from endwall: not in 9.00 ft GCp: 0.18 Wind Duration: 1.60	<b>Snow Criteria (Pg,Pf in PSF)</b> Pg: NA Ct: NA CAT: NA Pf: NA Ce: NA Lu: NA Cs: NA Snow Duration: NA  Building Code: FBC 8th Ed. 2023 Res. TPI Std: 2014 Rep Fac: Yes FT/RT:20(0)/10(0) Plate Type(s): WAVE	<b>Defl/CSI Criteria</b> PP Deflection in loc L/defl L/# VERT(LL): NA VERT(CL): NA HORZ(LL): 0.007 A - - HORZ(TL): 0.015 A - - Creep Factor: 2.0 Max TC CSI: 0.655 Max BC CSI: 0.378 Max Web CSI: 0.087  VIEW Ver: 24.02.00D.0114.10	<b>▲ Maximum Reactions (lbs), or *=PLF</b> Gravity Non-Gravity Loc R+ / R- / Rh / Rw / U / RL C* 88 /- /- /65 /9 /32 Wind reactions based on MWFRS C Brg Wid = 60.1 Min Req = - Bearing A is a rigid surface. Members not listed have forces less than 375# <b>Maximum Bot Chord Forces Per Ply (lbs)</b> Chords Tens.Comp. A - C 418 -90
--	---	--	---	---

**Lumber**

Top chord: 2x4 SP #2;  
Bot chord: 2x4 SP #2;  
Webs: 2x4 SP #3;

**Wind**

Wind loads based on MWFRS with additional C&C member design.  
Right end vertical not exposed to wind pressure.  
Wind loading based on both gable and hip roof types.

**Additional Notes**

See DWGS VALTN220723 and VAL180220723 for valley details.  
The overall height of this truss excluding overhang is 5'-0-6.

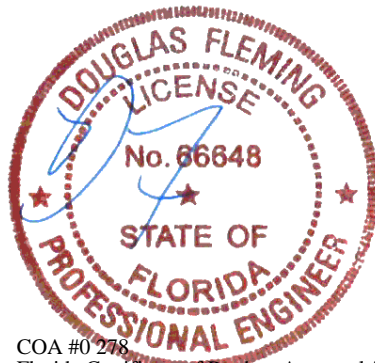

COA #0 278  
Florida Certificate of Product Approval #FL1999  
02/25/2026

**\*\*WARNING\*\* READ AND FOLLOW ALL NOTES ON THIS DRAWING!**  
**\*\*IMPORTANT\*\* FURNISH THIS DRAWING TO ALL CONTRACTORS INCLUDING THE INSTALLERS**  
Trusses require extreme care in fabricating, handling, shipping, installing and bracing. Refer to and follow the latest edition of BCSI (Building Component Safety Information, by TPI and SBCA) for safety practices prior to performing these functions. Installers shall provide temporary bracing per BCSI. Unless noted otherwise, top chord shall have properly attached structural sheathing and bottom chord shall have a properly attached rigid ceiling. Locations shown for permanent lateral restraint of webs shall have continuous lateral restraint (CLR), installed with diagonal bracing installed on the CLR per BCSI sections B3, B7, or B10, as applicable. Apply plates to each face of truss and position as shown above and on the Joint Details, unless noted otherwise. Refer to drawings 160A-Z for standard plate positions. Refer to job's General Notes page for additional information.  
Alpine, a division of ITW Building Components Group Inc. shall not be responsible for any deviation from this drawing, any failure to build the truss in conformance with ANSI/TPI 1, or for handling, shipping, installation and bracing of trusses. A seal on this drawing or cover page listing this drawing, indicates acceptance of professional engineering responsibility solely for the design shown. The suitability and use of this drawing for any structure is the responsibility of the Building Designer per ANSI/TPI 1 Sec.2.  
For more information see these web sites: Alpine: alpineitw.com; TPI: tpinst.org; SBCA: sbccomponents.com; ICC: iccsafe.org; AWC: awc.org



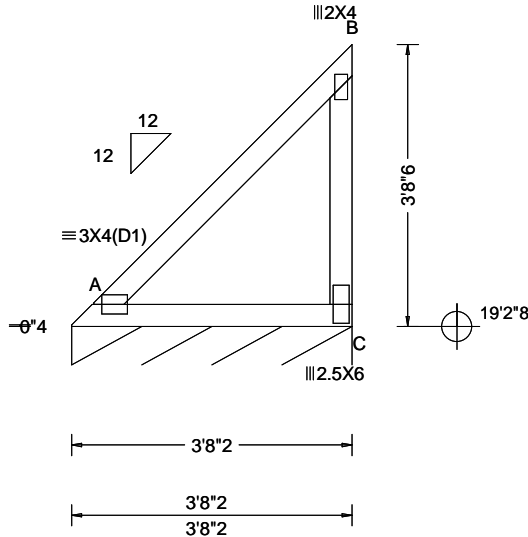

Loading Criteria (psf)	Wind Criteria	Snow Criteria (Pg,Pf in PSF)	Defl/CSI Criteria	▲ Maximum Reactions (lbs), or *=PLF
TCLL: 20.00 TCDL: 10.00 BCLL: 0.00 BCDL: 10.00 Des Ld: 40.00 NCBCLL: 10.00 Soffit: 2.00 Load Duration: 1.25 Spacing: 24.0 "	Wind Std: ASCE 7-22 Speed: 130 mph Enclosure: Enclosed Risk Category: II EXP: C Kzt: NA Mean Height: 21.21 ft TCDL: 5.0 psf BCDL: 5.0 psf MWFRS Parallel Dist: h/2 to h C&C Dist a: 3.00 ft Loc. from endwall: not in 9.00 ft GCp: 0.18 Wind Duration: 1.60	Pg: NA Ct: NA CAT: NA Pf: NA Ce: NA Lu: NA Cs: NA Snow Duration: NA  Building Code: FBC 8th Ed. 2023 Res. TPI Std: 2014 Rep Fac: Yes FT/RT:20(0)/10(0) Plate Type(s): WAVE	PP Deflection in loc L/defl L/# VERT(LL): NA VERT(CL): NA HORZ(LL): 0.002 A - - HORZ(TL): 0.005 A - - Creep Factor: 2.0 Max TC CSI: 0.330 Max BC CSI: 0.191 Max Web CSI: 0.162  VIEW Ver: 24.02.00D.0114.10	Gravity Non-Gravity Loc R+ / R- / Rh / Rw / U / RL C* 88 /- /- /63 /8 /31 Wind reactions based on MWFRS C Brg Wid = 44.1 Min Req = - Bearing A is a rigid surface. Members not listed have forces less than 375#

**Lumber**

Top chord: 2x4 SP #2;  
Bot chord: 2x4 SP #2;  
Webs: 2x4 SP #3;

**Wind**

Wind loads based on MWFRS with additional C&C member design.  
Right end vertical not exposed to wind pressure.  
Wind loading based on both gable and hip roof types.

**Additional Notes**

See DWGS VALTN220723 and VAL180220723 for valley details.  
The overall height of this truss excluding overhang is 3-8-6.

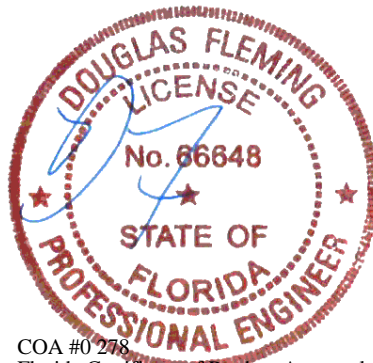

COA #0 278  
Florida Certificate of Product Approval #FL1999  
02/25/2026

**\*\*WARNING\*\* READ AND FOLLOW ALL NOTES ON THIS DRAWING!**  
**\*\*IMPORTANT\*\* FURNISH THIS DRAWING TO ALL CONTRACTORS INCLUDING THE INSTALLERS**  
Trusses require extreme care in fabricating, handling, shipping, installing and bracing. Refer to and follow the latest edition of BCSI (Building Component Safety Information, by TPI and SBCA) for safety practices prior to performing these functions. Installers shall provide temporary bracing per BCSI. Unless noted otherwise, top chord shall have properly attached structural sheathing and bottom chord shall have a properly attached rigid ceiling. Locations shown for permanent lateral restraint of webs shall have continuous lateral restraint (CLR), installed with diagonal bracing installed on the CLR per BCSI sections B3, B7, or B10, as applicable. Apply plates to each face of truss and position as shown above and on the Joint Details, unless noted otherwise. Refer to drawings 160A-Z for standard plate positions. Refer to job's General Notes page for additional information.  
Alpine, a division of ITW Building Components Group Inc. shall not be responsible for any deviation from this drawing, any failure to build the truss in conformance with ANSI/TPI 1, or for handling, shipping, installation and bracing of trusses. A seal on this drawing or cover page listing this drawing, indicates acceptance of professional engineering responsibility solely for the design shown. The suitability and use of this drawing for any structure is the responsibility of the Building Designer per ANSI/TPI 1 Sec.2.  
For more information see these web sites: Alpine: [alpineitw.com](http://alpineitw.com); TPI: [tpinst.org](http://tpinst.org); SBCA: [sbcacomponents.com](http://sbcacomponents.com); ICC: [iccsafe.org](http://iccsafe.org); AWC: [awc.org](http://awc.org)





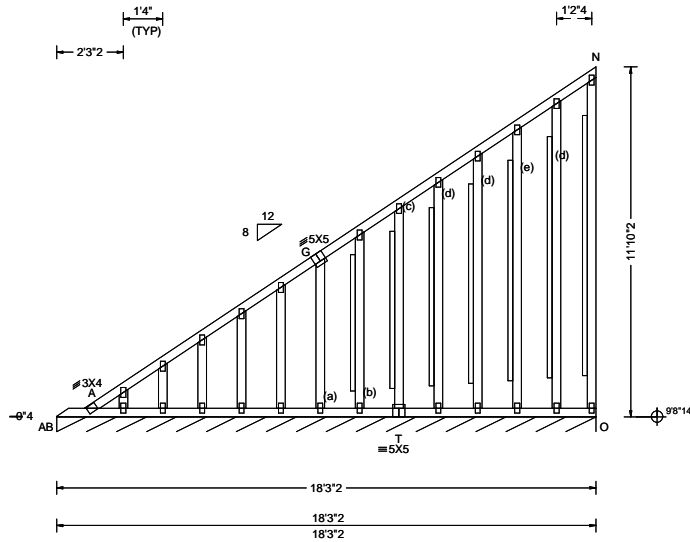

<b>Loading Criteria (psf)</b>	<b>Wind Criteria</b>	<b>Snow Criteria (Pg,Pf in PSF)</b>	<b>Defl/CSI Criteria</b>	<b>▲ Maximum Reactions (lbs), or *=PLF</b>
TCLL: 20.00 TCDL: 10.00 BCLL: 0.00 BCDL: 10.00 Des Ld: 40.00 NCBCLL: 10.00 Soffit: 2.00 Load Duration: 1.25 Spacing: 24.0 "	Wind Std: ASCE 7-22 Speed: 130 mph Enclosure: Enclosed Risk Category: II EXP: C Kzt: NA Mean Height: 15.81 ft TCDL: 5.0 psf BCDL: 5.0 psf MWFRS Parallel Dist: 0 to h/2 C&C Dist a: 3.00 ft Loc. from endwall: Any GCp: 0.18 Wind Duration: 1.60	Pg: NA Ct: NA CAT: NA Pf: NA Ce: NA Lu: NA Cs: NA Snow Duration: NA  Building Code: FBC 8th Ed. 2023 Res. TPI Std: 2014 Rep Fac: Varies by Ld Case FT/RT:20(0)/10(0) Plate Type(s): WAVE	PP Deflection in loc L/defl L/# VERT(LL): 0.004 M 999 360 VERT(CL): 0.003 M 999 240 HORZ(LL): 0.002 M - - HORZ(TL): 0.022 M - - Creep Factor: 2.0 Max TC CSI: 0.063 Max BC CSI: 0.095 Max Web CSI: 0.992  VIEW Ver: 24.02.00D.0114.10	<b>Gravity</b> Loc R+ / R- / Rh / Rw / U / RL O* 134 /- /- /72 /22 /32 Wind reactions based on MWFRS O Brg Wid = 219 Min Req = - Bearing AB is a rigid surface. Members not listed have forces less than 375# <b>Maximum Top Chord Forces Per Ply (lbs)</b> Chords Tens.Comp. Chords Tens. Comp. A - G 291 -995 G - N 158 -506  <b>Maximum Bot Chord Forces Per Ply (lbs)</b> Chords Tens.Comp. A - T 833 -243

**Lumber**

Top chord: 2x4 SP #2;  
Bot chord: 2x4 SP #2;  
Webs: 2x4 SP #3;

**Plating Notes**

All plates are 2X4 except as noted.

**Loading**

Truss designed to support 1-4-0 top chord outlookers and cladding load not to exceed 5.00 PSF one face and 24.0" span opposite face. Top chord must not be cut or notched, unless specified otherwise.

**Wind**

Wind loads based on MWFRS with additional C&C member design.  
Right end vertical not exposed to wind pressure.  
Wind loading based on both gable and hip roof types.  
Gable meets L/120 deflection criteria for wind load applied to face. Calculated deflection ratio is L/230.

**Additional Notes**

Exposed portion of gable face shall be reinforced with sheathing and the wind pressures shall be transferred into lateral diaphragms. Connections and designs for diaphragms is the responsibility of the Building Designer in accordance with ANSI/TPI 1.  
The overall height of this truss excluding overhang is 11-10-2.

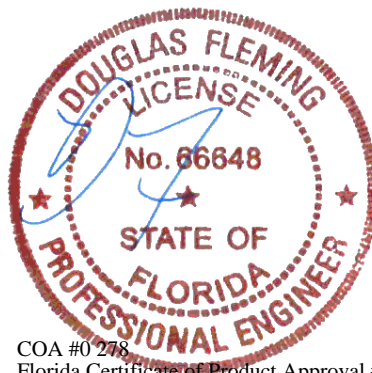

COA #0278  
Florida Certificate of Product Approval #FL1999  
02/25/2026

**\*\*WARNING\*\* READ AND FOLLOW ALL NOTES ON THIS DRAWING!**  
**\*\*IMPORTANT\*\* FURNISH THIS DRAWING TO ALL CONTRACTORS INCLUDING THE INSTALLERS**  
Trusses require extreme care in fabricating, handling, shipping, installing and bracing. Refer to and follow the latest edition of BCSI (Building Component Safety Information, by TPI and SBCA) for safety practices prior to performing these functions. Installers shall provide temporary bracing per BCSI. Unless noted otherwise, top chord shall have properly attached structural sheathing and bottom chord shall have a properly attached rigid ceiling. Locations shown for permanent lateral restraint of webs shall have continuous lateral restraint (CLR), installed with diagonal bracing installed on the CLR per BCSI sections B3, B7, or B10, as applicable. Apply plates to each face of truss and position as shown above and on the Joint Details, unless noted otherwise. Refer to drawings 160A-Z for standard plate positions. Refer to job's General Notes page for additional information.  
Alpine, a division of ITW Building Components Group Inc. shall not be responsible for any deviation from this drawing, any failure to build the truss in conformance with ANSI/TPI 1, or for handling, shipping, installation and bracing of trusses. A seal on this drawing or cover page listing this drawing, indicates acceptance of professional engineering responsibility solely for the design shown. The suitability and use of this drawing for any structure is the responsibility of the Building Designer per ANSI/TPI 1 Sec.2.  
For more information see these web sites: Alpine: alpineitw.com; TPI: tpinst.org; SBCA: sbccomponents.com; ICC: iccsafe.org; AWC: awc.org



SEQN: 727998	GABL	Ply: 1	Job Number: 26-3388d	Cust: R 215 JRef: 1YHX2150002 T38
FROM: RFG		Qty: 1	JOHNSON	DrwNo: 056.26.0834.29240
Page 2 of 2			Truss Label: MV11	JB / DF 02/25/2026

**Gable Reinforcement**

- (a) 2x3 "L" reinforcement. Same species and grade as web. 80% length of web member. Attach with 10d (0.131"x3",min.) nails @ 2" oc at each end for the first 18" and then 4" oc for the remainder.
- (b) 2x4 "L" reinforcement. Any species and grade. 80% length of web member. Attach with 10d (0.131"x3",min.) nails @ 2" oc at each end for the first 18" and then 4" oc for the remainder.
- (c) 2x4 "L" reinforcement. Same species and grade as web. 80% length of web member. Attach with 10d (0.131"x3",min.) nails @ 2" oc at each end for the first 18" and then 4" oc for the remainder.
- (d) 2x6 "L" reinforcement. Any species and grade. 80% length of web member. Attach with 10d (0.131"x3",min.) nails @ 2" oc at each end for the first 18" and then 4" oc for the remainder.
- (e) 2x6 "L" reinforcement. Same species and grade as web. 80% length of web member. Attach with 10d (0.131"x3",min.) nails @ 2" oc at each end for the first 18" and then 4" oc for the remainder.

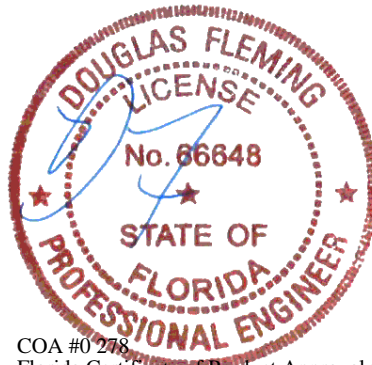

COA #0 278  
 Florida Certificate of Product Approval #FL1999  
 02/25/2026

**\*\*WARNING\*\* READ AND FOLLOW ALL NOTES ON THIS DRAWING!**  
**\*\*IMPORTANT\*\* FURNISH THIS DRAWING TO ALL CONTRACTORS INCLUDING THE INSTALLERS**  
 Trusses require extreme care in fabricating, handling, shipping, installing and bracing. Refer to and follow the latest edition of BCSI (Building Component Safety Information, by TPI and SBCA) for safety practices prior to performing these functions. Installers shall provide temporary bracing per BCSI. Unless noted otherwise, top chord shall have properly attached structural sheathing and bottom chord shall have a properly attached rigid ceiling. Locations shown for permanent lateral restraint of webs shall have continuous lateral restraint (CLR), installed with diagonal bracing installed on the CLR per BCSI sections B3, B7, or B10, as applicable. Apply plates to each face of truss and position as shown above and on the Joint Details, unless noted otherwise. Refer to drawings 160A-Z for standard plate positions. Refer to job's General Notes page for additional information.  
 Alpine, a division of ITW Building Components Group Inc. shall not be responsible for any deviation from this drawing, any failure to build the truss in conformance with ANSI/TPI 1, or for handling, shipping, installation and bracing of trusses. A seal on this drawing or cover page listing this drawing, indicates acceptance of professional engineering responsibility solely for the design shown. The suitability and use of this drawing for any structure is the responsibility of the Building Designer per ANSI/TPI 1 Sec.2.  
 For more information see these web sites: Alpine: [alpineitw.com](http://alpineitw.com); TPI: [tpinst.org](http://tpinst.org); SBCA: [sbcacomponents.com](http://sbcacomponents.com); ICC: [iccsafe.org](http://iccsafe.org); AWC: [awc.org](http://awc.org)



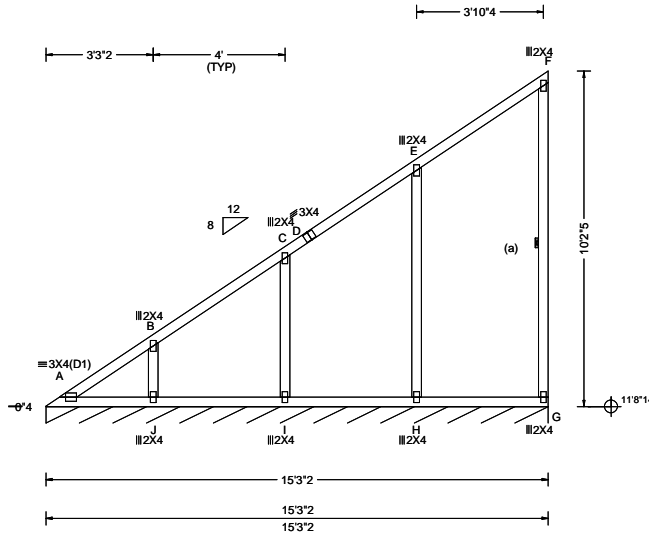

<b>Loading Criteria (psf)</b> TCLL: 20.00 TCDL: 10.00 BCLL: 0.00 BCDL: 10.00 Des Ld: 40.00 NCBCLL: 10.00 Soffit: 2.00 Load Duration: 1.25 Spacing: 24.0 "	<b>Wind Criteria</b> Wind Std: ASCE 7-22 Speed: 130 mph Enclosure: Enclosed Risk Category: II EXP: C Kzt: NA Mean Height: 16.99 ft TCDL: 5.0 psf BCDL: 5.0 psf MWFRS Parallel Dist: 0 to h/2 C&C Dist a: 3.00 ft Loc. from endwall: Any GCp: 0.18 Wind Duration: 1.60	<b>Snow Criteria (Pg,Pf in PSF)</b> Pg: NA Ct: NA CAT: NA Pf: NA Ce: NA Lu: NA Cs: NA Snow Duration: NA  Building Code: FBC 8th Ed. 2023 Res. TPI Std: 2014 Rep Fac: Yes FT/RT:20(0)/10(0) Plate Type(s): WAVE	<b>Defl/CSI Criteria</b> PP Deflection in loc L/defl L/# VERT(LL): 0.002 A 999 360 VERT(CL): 0.005 A 999 240 HORZ(LL): 0.001 A - - HORZ(TL): 0.016 E - - Creep Factor: 2.0 Max TC CSI: 0.257 Max BC CSI: 0.152 Max Web CSI: 0.297  VIEW Ver: 24.02.00D.0114.10	<b>▲ Maximum Reactions (lbs), or *=PLF</b> Gravity Non-Gravity Loc R+ / R- / Rh / Rw / U / RL G* 84 /- /- /58 /15 /25 Wind reactions based on MWFRS G Brg Wid = 183 Min Req = - Bearing A is a rigid surface. Members not listed have forces less than 375# <b>Maximum Top Chord Forces Per Ply (lbs)</b> Chords Tens.Comp. Chords Tens. Comp. A - B 179 -613 B - C 147 -472  <b>Maximum Bot Chord Forces Per Ply (lbs)</b> Chords Tens.Comp. Chords Tens. Comp. A - J 558 -143 I - H 574 -151 J - I 569 -149 H - G 578 -153
--	--	--	---	---

**Lumber**

Top chord: 2x4 SP #2;  
Bot chord: 2x4 SP #2;  
Webs: 2x4 SP #3;

**Bracing**

(a) Continuous lateral restraint equally spaced on member.

**Wind**

Wind loads based on MWFRS with additional C&C member design.  
Right end vertical not exposed to wind pressure.  
Wind loading based on both gable and hip roof types.

**Additional Notes**

See DWGS VALTN220723 and VAL180220723 for valley details.  
The overall height of this truss excluding overhang is 10-2-5.

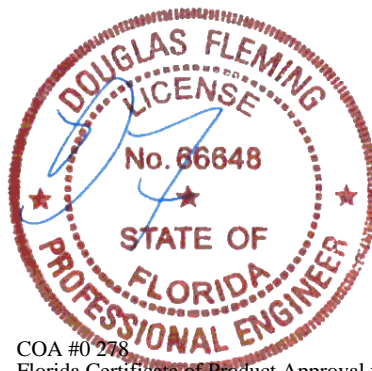

COA #0 278  
Florida Certificate of Product Approval #FL1999  
02/25/2026

**\*\*WARNING\*\* READ AND FOLLOW ALL NOTES ON THIS DRAWING!**  
**\*\*IMPORTANT\*\* FURNISH THIS DRAWING TO ALL CONTRACTORS INCLUDING THE INSTALLERS**  
Trusses require extreme care in fabricating, handling, shipping, installing and bracing. Refer to and follow the latest edition of BCSI (Building Component Safety Information, by TPI and SBCA) for safety practices prior to performing these functions. Installers shall provide temporary bracing per BCSI. Unless noted otherwise, top chord shall have properly attached structural sheathing and bottom chord shall have a properly attached rigid ceiling. Locations shown for permanent lateral restraint of webs shall have continuous lateral restraint (CLR), installed with diagonal bracing installed on the CLR per BCSI sections B3, B7, or B10, as applicable. Apply plates to each face of truss and position as shown above and on the Joint Details, unless noted otherwise. Refer to drawings 160A-Z for standard plate positions. Refer to job's General Notes page for additional information.  
Alpine, a division of ITW Building Components Group Inc. shall not be responsible for any deviation from this drawing, any failure to build the truss in conformance with ANSI/TPI 1, or for handling, shipping, installation and bracing of trusses. A seal on this drawing or cover page listing this drawing, indicates acceptance of professional engineering responsibility solely for the design shown. The suitability and use of this drawing for any structure is the responsibility of the Building Designer per ANSI/TPI 1 Sec.2.  
For more information see these web sites: Alpine: alpineitw.com; TPI: tpinst.org; SBCA: sbccomponents.com; ICC: iccsafe.org; AWC: awc.org



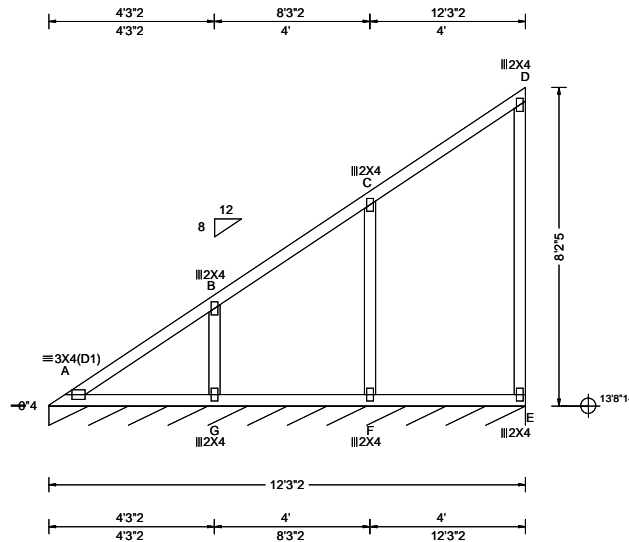

<b>Loading Criteria (psf)</b> TCLL: 20.00 TCDL: 10.00 BCLL: 0.00 BCDL: 10.00 Des Ld: 40.00 NCBCLL: 10.00 Soffit: 2.00 Load Duration: 1.25 Spacing: 24.0 "	<b>Wind Criteria</b> Wind Std: ASCE 7-22 Speed: 130 mph Enclosure: Enclosed Risk Category: II EXP: C Kzt: NA Mean Height: 17.99 ft TCDL: 5.0 psf BCDL: 5.0 psf MWFRS Parallel Dist: 0 to h/2 C&C Dist a: 3.00 ft Loc. from endwall: not in 4.50 ft GCp: 0.18 Wind Duration: 1.60	<b>Snow Criteria (Pg,Pf in PSF)</b> Pg: NA Ct: NA CAT: NA Pf: NA Ce: NA Lu: NA Cs: NA Snow Duration: NA  Building Code: FBC 8th Ed. 2023 Res. TPI Std: 2014 Rep Fac: Yes FT/RT:20(0)/10(0) Plate Type(s): WAVE	<b>Defl/CSI Criteria</b> PP Deflection in loc L/defl L/# VERT(LL): 0.007 A 999 360 VERT(CL): 0.015 A 999 240 HORZ(LL): 0.002 A - - HORZ(TL): 0.010 D - - Creep Factor: 2.0 Max TC CSI: 0.253 Max BC CSI: 0.157 Max Web CSI: 0.157  VIEW Ver: 24.02.00D.0114.10	<b>▲ Maximum Reactions (lbs), or *=PLF</b> Gravity Non-Gravity Loc R+ /R- /Rh /Rw /U /RL E* 84 /- /- /58 /16 /25 Wind reactions based on MWFRS E Brg Wid = 147 Min Req = - Bearing A is a rigid surface. Members not listed have forces less than 375# <b>Maximum Top Chord Forces Per Ply (lbs)</b> Chords Tens.Comp. A - B 145 -393  <b>Maximum Bot Chord Forces Per Ply (lbs)</b> Chords Tens.Comp. Chords Tens. Comp. A - G 379 -115 F - E 390 -122 G - F 386 -119
--	---	--	---	---

**Lumber**  
Top chord: 2x4 SP #2;  
Bot chord: 2x4 SP #2;  
Webs: 2x4 SP #3;

**Wind**  
Wind loads based on MWFRS with additional C&C member design.  
Right end vertical not exposed to wind pressure.  
Wind loading based on both gable and hip roof types.

**Additional Notes**  
See DWGS VALTN220723 and VAL180220723 for valley details.  
The overall height of this truss excluding overhang is 8'-2-5/8".

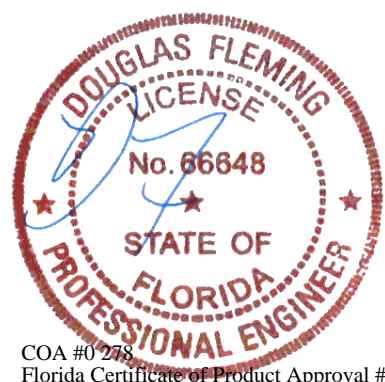

COA #0278  
Florida Certificate of Product Approval #FL1999  
02/25/2026

**\*\*WARNING\*\* READ AND FOLLOW ALL NOTES ON THIS DRAWING!**  
**\*\*IMPORTANT\*\* FURNISH THIS DRAWING TO ALL CONTRACTORS INCLUDING THE INSTALLERS**  
Trusses require extreme care in fabricating, handling, shipping, installing and bracing. Refer to and follow the latest edition of BCSI (Building Component Safety Information, by TPI and SBCA) for safety practices prior to performing these functions. Installers shall provide temporary bracing per BCSI. Unless noted otherwise, top chord shall have properly attached structural sheathing and bottom chord shall have a properly attached rigid ceiling. Locations shown for permanent lateral restraint of webs shall have continuous lateral restraint (CLR), installed with diagonal bracing installed on the CLR per BCSI sections B3, B7, or B10, as applicable. Apply plates to each face of truss and position as shown above and on the Joint Details, unless noted otherwise. Refer to drawings 160A-Z for standard plate positions. Refer to job's General Notes page for additional information.  
Alpine, a division of ITW Building Components Group Inc. shall not be responsible for any deviation from this drawing, any failure to build the truss in conformance with ANSI/TPI 1, or for handling, shipping, installation and bracing of trusses. A seal on this drawing or cover page listing this drawing, indicates acceptance of professional engineering responsibility solely for the design shown. The suitability and use of this drawing for any structure is the responsibility of the Building Designer per ANSI/TPI 1 Sec.2.  
For more information see these web sites: Alpine: alpineitw.com; TPI: tpinst.org; SBCA: sbcacomponents.com; ICC: iccsafe.org; AWC: awc.org



SEQN: 728004 FROM: RFG	VAL Ply: 1 Qty: 1	Job Number: 26-3388d JOHNSON Truss Label: MV14	Cust: R215 JRef: 1YHX2150002 T41 DrwNo: 056.26.0834.21817 JB / DF 02/25/2026
---------------------------	-------------------------	--	--

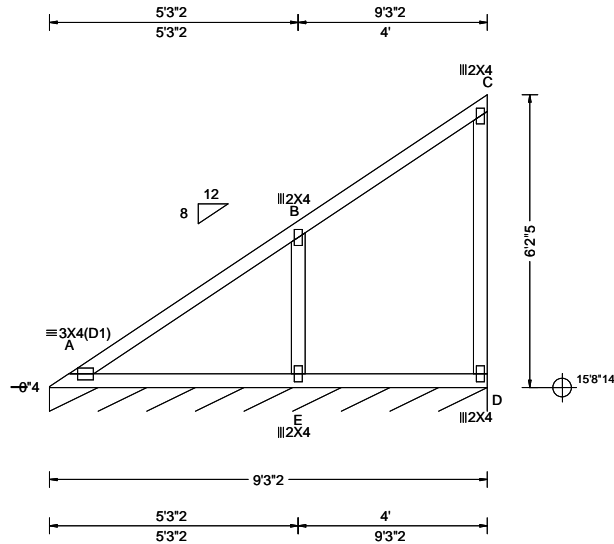

<b>Loading Criteria (psf)</b> TCLL: 20.00 TCDL: 10.00 BCLL: 0.00 BCDL: 10.00 Des Ld: 40.00 NCBCLL: 10.00 Soffit: 2.00 Load Duration: 1.25 Spacing: 24.0 "	<b>Wind Criteria</b> Wind Std: ASCE 7-22 Speed: 130 mph Enclosure: Enclosed Risk Category: II EXP: C Kzt: NA Mean Height: 18.99 ft TCDL: 5.0 psf BCDL: 5.0 psf MWFRS Parallel Dist: 0 to h/2 C&C Dist a: 3.00 ft Loc. from endwall: not in 4.50 ft GCp: 0.18 Wind Duration: 1.60	<b>Snow Criteria (Pg,Pf in PSF)</b> Pg: NA Ct: NA CAT: NA Pf: NA Ce: NA Lu: NA Cs: NA Snow Duration: NA  Building Code: FBC 8th Ed. 2023 Res. TPI Std: 2014 Rep Fac: Yes FT/RT:20(0)/10(0) Plate Type(s): WAVE	<b>Defl/CSI Criteria</b> PP Deflection in loc L/defl L/# VERT(LL): 0.013 A 999 360 VERT(CL): 0.027 A 999 240 HORZ(LL): 0.004 A - - HORZ(TL): 0.009 A - - Creep Factor: 2.0 Max TC CSI: 0.360 Max BC CSI: 0.253 Max Web CSI: 0.110  VIEW Ver: 24.02.00D.0114.10	<b>▲ Maximum Reactions (lbs), or *=PLF</b> Gravity Non-Gravity Loc R+ / R- / Rh / Rw / U / RL D* 84 /- /- /58 /17 /26 Wind reactions based on MWFRS D Brg Wid = 111 Min Req = - Bearing A is a rigid surface. Members not listed have forces less than 375#
--	---	--	---	--

**Lumber**

Top chord: 2x4 SP #2;  
Bot chord: 2x4 SP #2;  
Webs: 2x4 SP #3;

**Wind**

Wind loads based on MWFRS with additional C&C member design.  
Right end vertical not exposed to wind pressure.  
Wind loading based on both gable and hip roof types.

**Additional Notes**

See DWGS VALTN220723 and VAL180220723 for valley details.  
The overall height of this truss excluding overhang is 6'-2-5".

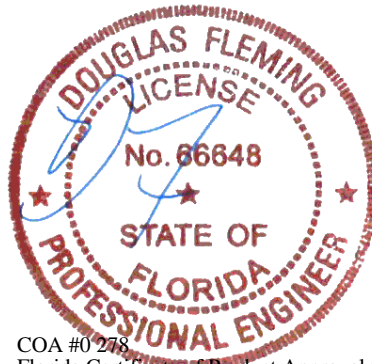

COA #0278  
Florida Certificate of Product Approval #FL1999  
02/25/2026

**\*\*WARNING\*\* READ AND FOLLOW ALL NOTES ON THIS DRAWING!**  
**\*\*IMPORTANT\*\* FURNISH THIS DRAWING TO ALL CONTRACTORS INCLUDING THE INSTALLERS**  
Trusses require extreme care in fabricating, handling, shipping, installing and bracing. Refer to and follow the latest edition of BCSI (Building Component Safety Information, by TPI and SBCA) for safety practices prior to performing these functions. Installers shall provide temporary bracing per BCSI. Unless noted otherwise, top chord shall have properly attached structural sheathing and bottom chord shall have a properly attached rigid ceiling. Locations shown for permanent lateral restraint of webs shall have continuous lateral restraint (CLR), installed with diagonal bracing installed on the CLR per BCSI sections B3, B7, or B10, as applicable. Apply plates to each face of truss and position as shown above and on the Joint Details, unless noted otherwise. Refer to drawings 160A-Z for standard plate positions. Refer to job's General Notes page for additional information.  
Alpine, a division of ITW Building Components Group Inc. shall not be responsible for any deviation from this drawing, any failure to build the truss in conformance with ANSI/TPI 1, or for handling, shipping, installation and bracing of trusses. A seal on this drawing or cover page listing this drawing, indicates acceptance of professional engineering responsibility solely for the design shown. The suitability and use of this drawing for any structure is the responsibility of the Building Designer per ANSI/TPI 1 Sec.2.  
For more information see these web sites: Alpine: [alpineitw.com](http://alpineitw.com); TPI: [tpinst.org](http://tpinst.org); SBCA: [sbcacomponents.com](http://sbcacomponents.com); ICC: [iccsafe.org](http://iccsafe.org); AWC: [awc.org](http://awc.org)



SEQN: 728006 FROM: RFG	VAL Ply: 1 Qty: 1	Job Number: 26-3388d JOHNSON Truss Label: MV15	Cust: R215 JRef: 1YHX2150002 T42 DrwNo: 056.26.0834.20167 JB / DF 02/25/2026
---------------------------	-------------------------	--	--

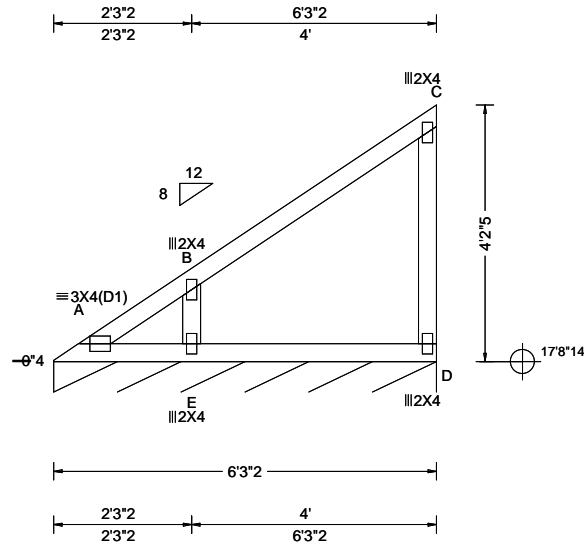

<b>Loading Criteria (psf)</b> TCLL: 20.00 TCDL: 10.00 BCLL: 0.00 BCDL: 10.00 Des Ld: 40.00 NCBCLL: 10.00 Soffit: 2.00 Load Duration: 1.25 Spacing: 24.0 "	<b>Wind Criteria</b> Wind Std: ASCE 7-22 Speed: 130 mph Enclosure: Enclosed Risk Category: II EXP: C Kzt: NA Mean Height: 19.99 ft TCDL: 5.0 psf BCDL: 5.0 psf MWFRS Parallel Dist: 0 to h/2 C&C Dist a: 3.00 ft Loc. from endwall: not in 9.00 ft GCp: 0.18 Wind Duration: 1.60	<b>Snow Criteria (Pg,Pf in PSF)</b> Pg: NA Ct: NA CAT: NA Pf: NA Ce: NA Lu: NA Cs: NA Snow Duration: NA  Building Code: FBC 8th Ed. 2023 Res. TPI Std: 2014 Rep Fac: Yes FT/RT:20(0)/10(0) Plate Type(s): WAVE	<b>Defl/CSI Criteria</b> PP Deflection in loc L/defl L/# VERT(LL): 0.000 C 999 360 VERT(CL): 0.001 A 999 240 HORZ(LL): 0.000 C - - HORZ(TL): 0.003 C - - Creep Factor: 2.0 Max TC CSI: 0.243 Max BC CSI: 0.117 Max Web CSI: 0.118  VIEW Ver: 24.02.00D.0114.10	<b>▲ Maximum Reactions (lbs), or *=PLF</b> Gravity Non-Gravity Loc R+ / R- / Rh / Rw / U / RL D* 84 /- /- /57 /17 /26 Wind reactions based on MWFRS D Brg Wid = 75.1 Min Req = - Bearing A is a rigid surface. Members not listed have forces less than 375#
--	---	--	---	---

**Lumber**

Top chord: 2x4 SP #2;  
Bot chord: 2x4 SP #2;  
Webs: 2x4 SP #3;

**Wind**

Wind loads based on MWFRS with additional C&C member design.  
Right end vertical not exposed to wind pressure.  
Wind loading based on both gable and hip roof types.

**Additional Notes**

See DWGS VALTN220723 and VAL180220723 for valley details.  
The overall height of this truss excluding overhang is 4-2-5.

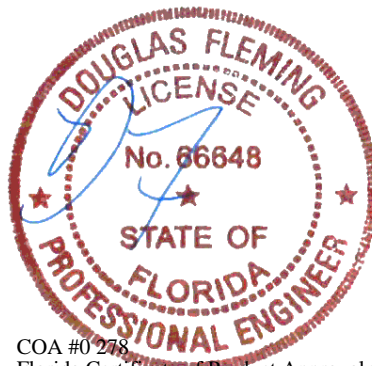

COA #0 278  
Florida Certificate of Product Approval #FL1999  
02/25/2026

**\*\*WARNING\*\* READ AND FOLLOW ALL NOTES ON THIS DRAWING!**  
**\*\*IMPORTANT\*\* FURNISH THIS DRAWING TO ALL CONTRACTORS INCLUDING THE INSTALLERS**  
Trusses require extreme care in fabricating, handling, shipping, installing and bracing. Refer to and follow the latest edition of BCSI (Building Component Safety Information, by TPI and SBCA) for safety practices prior to performing these functions. Installers shall provide temporary bracing per BCSI. Unless noted otherwise, top chord shall have properly attached structural sheathing and bottom chord shall have a properly attached rigid ceiling. Locations shown for permanent lateral restraint of webs shall have continuous lateral restraint (CLR), installed with diagonal bracing installed on the CLR per BCSI sections B3, B7, or B10, as applicable. Apply plates to each face of truss and position as shown above and on the Joint Details, unless noted otherwise. Refer to drawings 160A-Z for standard plate positions. Refer to job's General Notes page for additional information.  
Alpine, a division of ITW Building Components Group Inc. shall not be responsible for any deviation from this drawing, any failure to build the truss in conformance with ANSI/TPI 1, or for handling, shipping, installation and bracing of trusses. A seal on this drawing or cover page listing this drawing, indicates acceptance of professional engineering responsibility solely for the design shown. The suitability and use of this drawing for any structure is the responsibility of the Building Designer per ANSI/TPI 1 Sec.2.  
For more information see these web sites: Alpine: alpineitw.com; TPI: tpinst.org; SBCA: sbccomponents.com; ICC: iccsafe.org; AWC: awc.org



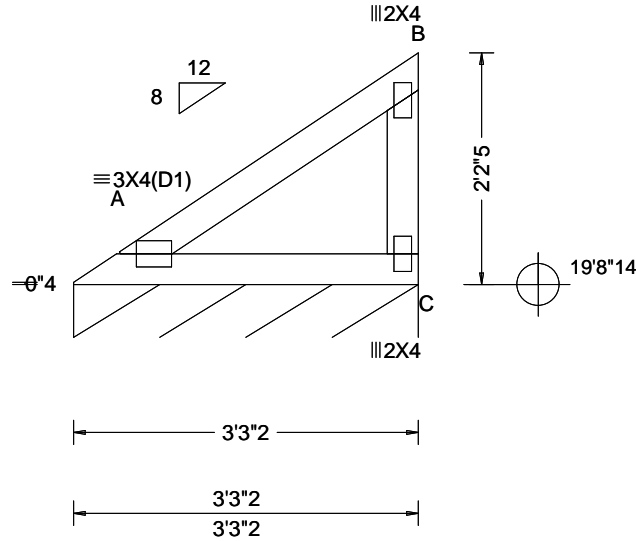

Loading Criteria (psf)	Wind Criteria	Snow Criteria (Pg,Pf in PSF)	Defl/CSI Criteria	▲ Maximum Reactions (lbs), or *=PLF
TCCL: 20.00 TCCL: 10.00 BCLL: 0.00 BCDL: 10.00 Des Ld: 40.00 NCBCLL: 10.00 Soffit: 2.00 Load Duration: 1.25 Spacing: 24.0 "	Wind Std: ASCE 7-22 Speed: 130 mph Enclosure: Enclosed Risk Category: II EXP: C Kzt: NA Mean Height: 20.99 ft TCCL: 5.0 psf BCDL: 5.0 psf MWFRS Parallel Dist: h/2 to h C&C Dist a: 3.00 ft Loc. from endwall: not in 9.00 ft GCp: 0.18 Wind Duration: 1.60	Pg: NA Ct: NA CAT: NA Pf: NA Ce: NA Lu: NA Cs: NA Snow Duration: NA Building Code: FBC 8th Ed. 2023 Res. TPI Std: 2014 Rep Fac: Yes FT/RT:20(0)/10(0) Plate Type(s): WAVE	PP Deflection in loc L/defl L/# VERT(LL): NA VERT(CL): NA HORZ(LL): 0.002 A - - HORZ(TL): 0.003 A - - Creep Factor: 2.0 Max TC CSI: 0.139 Max BC CSI: 0.099 Max Web CSI: 0.070 VIEW Ver: 24.02.00D.0114.10	Gravity Non-Gravity Loc R+ / R- / Rh / Rw / U / RL C* 84 /- /- /54 /9 /20 Wind reactions based on MWFRS C Brg Wid = 39.1 Min Req = - Bearing A is a rigid surface. Members not listed have forces less than 375#

**Lumber**

Top chord: 2x4 SP #2;  
 Bot chord: 2x4 SP #2;  
 Webs: 2x4 SP #3;

**Wind**

Wind loads based on MWFRS with additional C&C member design.  
 Right end vertical not exposed to wind pressure.  
 Wind loading based on both gable and hip roof types.

**Additional Notes**

See DWGS VALTN220723 and VAL180220723 for valley details.  
 The overall height of this truss excluding overhang is 2-2-5.

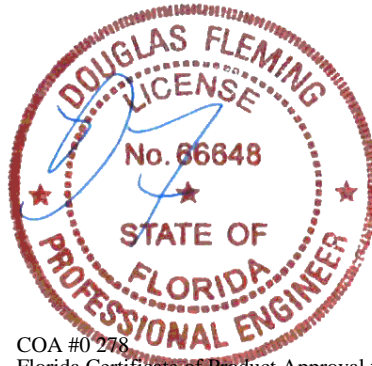

COA #0 278  
 Florida Certificate of Product Approval #FL1999  
 02/25/2026

**\*\*WARNING\*\* READ AND FOLLOW ALL NOTES ON THIS DRAWING!**  
**\*\*IMPORTANT\*\* FURNISH THIS DRAWING TO ALL CONTRACTORS INCLUDING THE INSTALLERS**  
 Trusses require extreme care in fabricating, handling, shipping, installing and bracing. Refer to and follow the latest edition of BCSI (Building Component Safety Information, by TPI and SBCA) for safety practices prior to performing these functions. Installers shall provide temporary bracing per BCSI. Unless noted otherwise, top chord shall have properly attached structural sheathing and bottom chord shall have a properly attached rigid ceiling. Locations shown for permanent lateral restraint of webs shall have continuous lateral restraint (CLR), installed with diagonal bracing installed on the CLR per BCSI sections B3, B7, or B10, as applicable. Apply plates to each face of truss and position as shown above and on the Joint Details, unless noted otherwise. Refer to drawings 160A-Z for standard plate positions. Refer to job's General Notes page for additional information.  
 Alpine, a division of ITW Building Components Group Inc. shall not be responsible for any deviation from this drawing, any failure to build the truss in conformance with ANSI/TPI 1, or for handling, shipping, installation and bracing of trusses. A seal on this drawing or cover page listing this drawing, indicates acceptance of professional engineering responsibility solely for the design shown. The suitability and use of this drawing for any structure is the responsibility of the Building Designer per ANSI/TPI 1 Sec.2.  
 For more information see these web sites: Alpine: [alpineitw.com](http://alpineitw.com); TPI: [tpinst.org](http://tpinst.org); SBCA: [sbcacomponents.com](http://sbcacomponents.com); ICC: [iccsafe.org](http://iccsafe.org); AWC: [awc.org](http://awc.org)



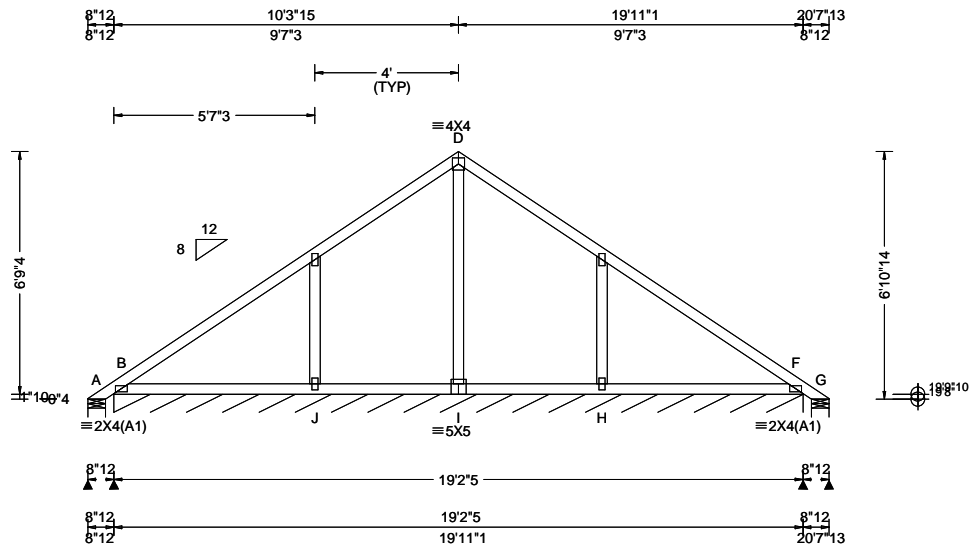

<b>Loading Criteria (psf)</b> TCCL: 20.00 TCCL: 10.00 BCLL: 0.00 BCDL: 10.00 Des Ld: 40.00 NCBCLL: 10.00 Soffit: 2.00 Load Duration: 1.25 Spacing: 24.0 "	<b>Wind Criteria</b> Wind Std: ASCE 7-22 Speed: 130 mph Enclosure: Enclosed Risk Category: II EXP: C Kzt: NA Mean Height: 17.41 ft TCCL: 5.0 psf BCDL: 5.0 psf MWFRS Parallel Dist: h to 2h C&C Dist a: 3.51 ft Loc. from endwall: not in 13.00 ft GCp: 0.18 Wind Duration: 1.60	<b>Snow Criteria (Pg,Pf in PSF)</b> Pg: NA Ct: NA CAT: NA Pf: NA Ce: NA Lu: NA Cs: NA Snow Duration: NA Building Code: FBC 8th Ed. 2023 Res. TPI Std: 2014 Rep Fac: Yes FT/RT:20(0)/10(0) Plate Type(s): WAVE	<b>Defl/CSI Criteria</b> PP Deflection in loc L/defl L/# VERT(LL): 0.002 B 999 360 VERT(CL): 0.003 B 999 240 HORZ(LL): 0.002 B - - HORZ(TL): 0.004 E - - Creep Factor: 2.0 Max TC CSI: 0.283 Max BC CSI: 0.154 Max Web CSI: 0.108 VIEW Ver: 24.02.00D.0114.10	<b>▲ Maximum Reactions (lbs), or *=PLF</b> Gravity Non-Gravity																																													
				<table border="1"> <thead> <tr> <th>Loc</th> <th>R+</th> <th>/R-</th> <th>/Rh</th> <th>/Rw</th> <th>/U</th> <th>/RL</th> </tr> </thead> <tbody> <tr> <td>A</td> <td>-</td> <td>/-145</td> <td>/-</td> <td>/178</td> <td>/261</td> <td>/203</td> </tr> <tr> <td>B*</td> <td>87</td> <td>/-</td> <td>/-</td> <td>/65</td> <td>/13</td> <td>/-</td> </tr> <tr> <td>G</td> <td>-</td> <td>/-145</td> <td>/-</td> <td>/68</td> <td>/151</td> <td>/-</td> </tr> <tr> <td>B</td> <td></td> <td>/-139</td> <td></td> <td></td> <td></td> <td></td> </tr> <tr> <td>J</td> <td></td> <td>/-121</td> <td></td> <td></td> <td></td> <td></td> </tr> <tr> <td>H</td> <td></td> <td>/-121</td> <td></td> <td></td> <td></td> <td></td> </tr> </tbody> </table> Wind reactions based on MWFRS A Brg Wid = 5.9 Min Req = 1.5 (Truss) B Brg Wid = 230 Min Req = - G Brg Wid = 5.9 Min Req = 1.5 (Truss) Bearings A, B, & G are a rigid surface. Members not listed have forces less than 375#	Loc	R+	/R-	/Rh	/Rw	/U	/RL	A	-	/-145	/-	/178	/261	/203	B*	87	/-	/-	/65	/13	/-	G	-	/-145	/-	/68	/151	/-	B		/-139					J		/-121					H		/-121
Loc	R+	/R-	/Rh	/Rw	/U	/RL																																											
A	-	/-145	/-	/178	/261	/203																																											
B*	87	/-	/-	/65	/13	/-																																											
G	-	/-145	/-	/68	/151	/-																																											
B		/-139																																															
J		/-121																																															
H		/-121																																															

**Lumber**

Top chord: 2x4 SP #2;  
 Bot chord: 2x4 SP #2;  
 Webs: 2x4 SP #3;

**Plating Notes**

All plates are 2X4 except as noted.

**Wind**

Wind loads based on MWFRS with additional C&C member design.  
 Wind loading based on both gable and hip roof types.

**Additional Notes**

Refer to DWG PB160220723 for piggyback details.  
 The overall height of this truss excluding overhang is 6-10-14.

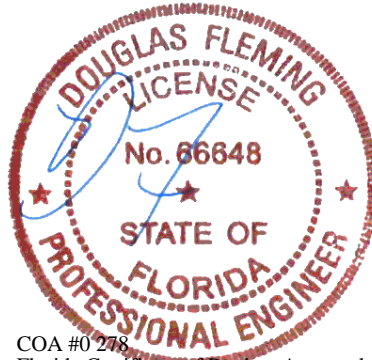

COA #0 278  
 Florida Certificate of Product Approval #FL1999  
 02/25/2026

**\*\*WARNING\*\* READ AND FOLLOW ALL NOTES ON THIS DRAWING!**  
**\*\*IMPORTANT\*\* FURNISH THIS DRAWING TO ALL CONTRACTORS INCLUDING THE INSTALLERS**  
 Trusses require extreme care in fabricating, handling, shipping, installing and bracing. Refer to and follow the latest edition of BCSI (Building Component Safety Information, by TPI and SBCA) for safety practices prior to performing these functions. Installers shall provide temporary bracing per BCSI. Unless noted otherwise, top chord shall have properly attached structural sheathing and bottom chord shall have a properly attached rigid ceiling. Locations shown for permanent lateral restraint of webs shall have continuous lateral restraint (CLR), installed with diagonal bracing installed on the CLR per BCSI sections B3, B7, or B10, as applicable. Apply plates to each face of truss and position as shown above and on the Joint Details, unless noted otherwise. Refer to drawings 160A-Z for standard plate positions. Refer to job's General Notes page for additional information.  
 Alpine, a division of ITW Building Components Group Inc. shall not be responsible for any deviation from this drawing, any failure to build the truss in conformance with ANSI/TPI 1, or for handling, shipping, installation and bracing of trusses. A seal on this drawing or cover page listing this drawing, indicates acceptance of professional engineering responsibility solely for the design shown. The suitability and use of this drawing for any structure is the responsibility of the Building Designer per ANSI/TPI 1 Sec.2.  
 For more information see these web sites: Alpine: alpineitw.com; TPI: tpinst.org; SBCA: sbccomponents.com; ICC: iccsafe.org; AWC: awc.org



SEQN: 728207 FROM: RFG	GABL Ply: 1 Qty: 1	Job Number: 26-3388d JOHNSON Truss Label: P1E	Cust: R 215 JRef: 1YHX2150002 T4 DrwNo: 056.26.0834.03060 JB / DF 02/25/2026
---------------------------	--------------------------	---	--

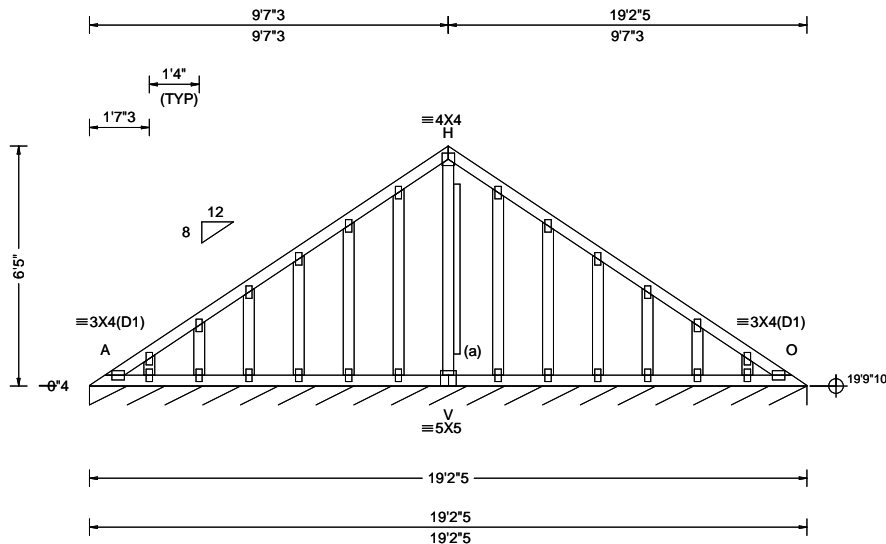

<b>Loading Criteria (psf)</b> TCLL: 20.00 TCDL: 10.00 BCLL: 0.00 BCDL: 10.00 Des Ld: 40.00 NCBCLL: 10.00 Soffit: 2.00 Load Duration: 1.25 Spacing: 24.0 "	<b>Wind Criteria</b> Wind Std: ASCE 7-22 Speed: 130 mph Enclosure: Enclosed Risk Category: II EXP: C Kzt: NA Mean Height: 17.41 ft TCDL: 5.0 psf BCDL: 5.0 psf MWFRS Parallel Dist: 0 to h/2 C&C Dist a: 3.51 ft Loc. from endwall: Any GCpi: 0.18 Wind Duration: 1.60	<b>Snow Criteria (Pg,Pf in PSF)</b> Pg: NA Ct: NA CAT: NA Pf: NA Ce: NA Lu: NA Cs: NA Snow Duration: NA  Building Code: FBC 8th Ed. 2023 Res. TPI Std: 2014 Rep Fac: Yes FT/RT:20(0)/10(0) Plate Type(s): WAVE	<b>Defl/CSI Criteria</b> PP Deflection in loc L/defl L/# VERT(LL): 0.000 A 999 360 VERT(CL): 0.001 A 999 240 HORZ(LL): -0.000 B - - HORZ(TL): 0.000 B - - Creep Factor: 2.0 Max TC CSI: 0.022 Max BC CSI: 0.019 Max Web CSI: 0.865  VIEW Ver: 24.02.00D.0114.10	<b>▲ Maximum Reactions (lbs), or *=PLF</b> Gravity Non-Gravity Loc R+ /R- /Rh /Rw /U /RL A* 67 /- /- /39 /- /- Wind reactions based on MWFRS A Brg Wid = 230 Min Req = - Bearing A is a rigid surface. Members not listed have forces less than 375#
--	---	--	--	---

**Lumber**  
Top chord: 2x4 SP #2;  
Bot chord: 2x4 SP #2;  
Webs: 2x4 SP #3;

**Plating Notes**  
All plates are 2X4 except as noted.

**Purlins**  
In lieu of structural panels use purlins to brace TC @ 24" oc.

**Wind**  
Wind loads based on MWFRS with additional C&C member design.  
Wind loading based on both gable and hip roof types.  
Gable meets L/120 deflection criteria for wind load applied to face. Calculated deflection ratio is L/208.

**Gable Reinforcement**  
(a) 2x6 "L" reinforcement. Any species and grade. 80% length of web member. Attach with 10d (0.131"x3",min.) nails @ 2" oc at each end for the first 18" and then 4" oc for the remainder.

**Additional Notes**  
Exposed portion of gable face shall be reinforced with sheathing and the wind pressures shall be transferred into lateral diaphragms. Connections and designs for diaphragms is the responsibility of the Building Designer in accordance with ANSI/TPI 1.  
Refer to DWG PB160220723 for piggyback details.  
The overall height of this truss excluding overhang is 6-6-10.

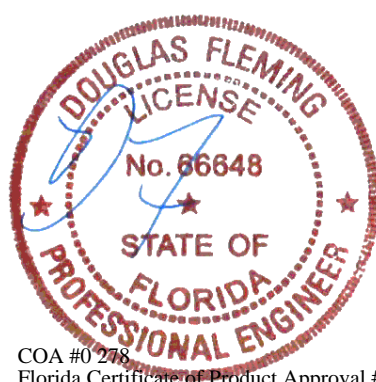

COA #0 278  
Florida Certificate of Product Approval #FL1999  
02/25/2026

**\*\*WARNING\*\* READ AND FOLLOW ALL NOTES ON THIS DRAWING!**  
**\*\*IMPORTANT\*\* FURNISH THIS DRAWING TO ALL CONTRACTORS INCLUDING THE INSTALLERS**  
Trusses require extreme care in fabricating, handling, shipping, installing and bracing. Refer to and follow the latest edition of BCSI (Building Component Safety Information, by TPI and SBCA) for safety practices prior to performing these functions. Installers shall provide temporary bracing per BCSI. Unless noted otherwise, top chord shall have properly attached structural sheathing and bottom chord shall have a properly attached rigid ceiling. Locations shown for permanent lateral restraint of webs shall have continuous lateral restraint (CLR), installed with diagonal bracing installed on the CLR per BCSI sections B3, B7, or B10, as applicable. Apply plates to each face of truss and position as shown above and on the Joint Details, unless noted otherwise. Refer to drawings 160A-Z for standard plate positions. Refer to job's General Notes page for additional information.  
Alpine, a division of ITW Building Components Group Inc. shall not be responsible for any deviation from this drawing, any failure to build the truss in conformance with ANSI/TPI 1, or for handling, shipping, installation and bracing of trusses. A seal on this drawing or cover page listing this drawing, indicates acceptance of professional engineering responsibility solely for the design shown. The suitability and use of this drawing for any structure is the responsibility of the Building Designer per ANSI/TPI 1 Sec.2.  
For more information see these web sites: Alpine: alpineitw.com; TPI: tpinst.org; SBCA: sbccomponents.com; ICC: iccsafe.org; AWC: awc.org





SEQN: 727991 FROM: RFG	GABL Ply: 1 Qty: 1	Job Number: 26-3388d JOHNSON Truss Label: P2E	Cust: R215 JRef: 1YHX2150002 T21 DrwNo: 056.26.0833.57750 JB / DF 02/25/2026
---------------------------	--------------------------	---	--

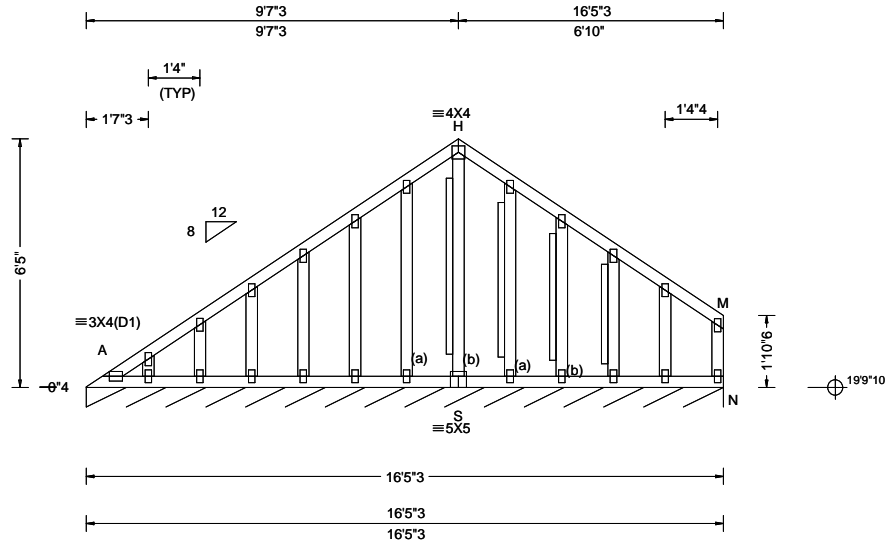

<b>Loading Criteria (psf)</b> TCCL: 20.00 TCDL: 10.00 BCLL: 0.00 BCDL: 10.00 Des Ld: 40.00 NCBCLL: 10.00 Soffit: 2.00 Load Duration: 1.25 Spacing: 24.0 "	<b>Wind Criteria</b> Wind Std: ASCE 7-22 Speed: 130 mph Enclosure: Enclosed Risk Category: II EXP: C Kzt: NA Mean Height: 17.40 ft TCDL: 5.0 psf BCDL: 5.0 psf MWFRS Parallel Dist: 0 to h/2 C&C Dist a: 3.23 ft Loc. from endwall: Any GCpi: 0.18 Wind Duration: 1.60	<b>Snow Criteria (Pg,Pf in PSF)</b> Pg: NA Ct: NA CAT: NA Pf: NA Ce: NA Lu: NA Cs: NA Snow Duration: NA  Building Code: FBC 8th Ed. 2023 Res. TPI Std: 2014 Rep Fac: Yes FT/RT:20(0)/10(0) Plate Type(s): WAVE	<b>Defl/CSI Criteria</b> PP Deflection in loc L/defl L/# VERT(LL): 0.000 A 999 360 VERT(CL): 0.000 A 999 240 HORZ(LL): 0.000 A - - HORZ(TL): 0.000 A - - Creep Factor: 2.0 Max TC CSI: 0.022 Max BC CSI: 0.015 Max Web CSI: 0.976  VIEW Ver: 24.02.00D.0114.10	<b>▲ Maximum Reactions (lbs), or *=PLF</b> <table border="1"> <thead> <tr> <th colspan="3">Gravity</th> <th colspan="3">Non-Gravity</th> </tr> <tr> <th>Loc</th> <th>R+</th> <th>/R-</th> <th>/Rh</th> <th>/Rw</th> <th>/U</th> <th>/RL</th> </tr> </thead> <tbody> <tr> <td>A*</td> <td>66</td> <td>/-</td> <td>/-</td> <td>/39</td> <td>/-</td> <td>/-</td> </tr> </tbody> </table> Wind reactions based on MWFRS A Brg Wid = 197 Min Req = - Bearing A is a rigid surface. Members not listed have forces less than 375#	Gravity			Non-Gravity			Loc	R+	/R-	/Rh	/Rw	/U	/RL	A*	66	/-	/-	/39	/-	/-
Gravity			Non-Gravity																					
Loc	R+	/R-	/Rh	/Rw	/U	/RL																		
A*	66	/-	/-	/39	/-	/-																		

**Lumber**  
 Top chord: 2x4 SP #2;  
 Bot chord: 2x4 SP #2;  
 Webs: 2x4 SP #3;

**Plating Notes**  
 All plates are 2X4 except as noted.

**Purlins**  
 In lieu of structural panels use purlins to brace TC @ 24" oc.

**Wind**  
 Wind loads based on MWFRS with additional C&C member design.  
 Right end vertical not exposed to wind pressure.  
 Wind loading based on both gable and hip roof types.  
 Gable meets L/120 deflection criteria for wind load applied to face. Calculated deflection ratio is L/205.

**Gable Reinforcement**  
 (a) 2x4 "L" reinforcement. Any species and grade. 80% length of web member. Attach with 10d (0.131"x3",min.) nails @ 2" oc at each end for the first 18" and then 4" oc for the remainder.  
 (b) 2x6 "L" reinforcement. Any species and grade. 80% length of web member. Attach with 10d (0.131"x3",min.) nails @ 2" oc at each end for the first 18" and then 4" oc for the remainder.

**Additional Notes**  
 Exposed portion of gable face shall be reinforced with sheathing and the wind pressures shall be transferred into lateral diaphragms. Connections and designs for diaphragms is the responsibility of the Building Designer in accordance with ANSI/TPI 1.  
 Refer to DWG PB160220723 for piggyback details.  
 The overall height of this truss excluding overhang is 6-6-10.

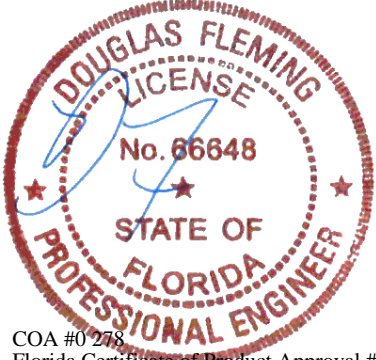

COA #0278  
 Florida Certificate of Product Approval #FL1999  
 02/25/2026

**\*\*WARNING\*\* READ AND FOLLOW ALL NOTES ON THIS DRAWING!**  
**\*\*IMPORTANT\*\* FURNISH THIS DRAWING TO ALL CONTRACTORS INCLUDING THE INSTALLERS**  
 Trusses require extreme care in fabricating, handling, shipping, installing and bracing. Refer to and follow the latest edition of BCSI (Building Component Safety Information, by TPI and SBCA) for safety practices prior to performing these functions. Installers shall provide temporary bracing per BCSI. Unless noted otherwise, top chord shall have properly attached structural sheathing and bottom chord shall have a properly attached rigid ceiling. Locations shown for permanent lateral restraint of webs shall have continuous lateral restraint (CLR), installed with diagonal bracing installed on the CLR per BCSI sections B3, B7, or B10, as applicable. Apply plates to each face of truss and position as shown above and on the Joint Details, unless noted otherwise. Refer to drawings 160A-Z for standard plate positions. Refer to job's General Notes page for additional information.  
 Alpine, a division of ITW Building Components Group Inc. shall not be responsible for any deviation from this drawing, any failure to build the truss in conformance with ANSI/TPI 1, or for handling, shipping, installation and bracing of trusses. A seal on this drawing or cover page listing this drawing, indicates acceptance of professional engineering responsibility solely for the design shown. The suitability and use of this drawing for any structure is the responsibility of the Building Designer per ANSI/TPI 1 Sec.2.  
 For more information see these web sites: Alpine: alpineitw.com; TPI: tpinst.org; SBCA: sbcacomponents.com; ICC: iccsafe.org; AWC: awc.org



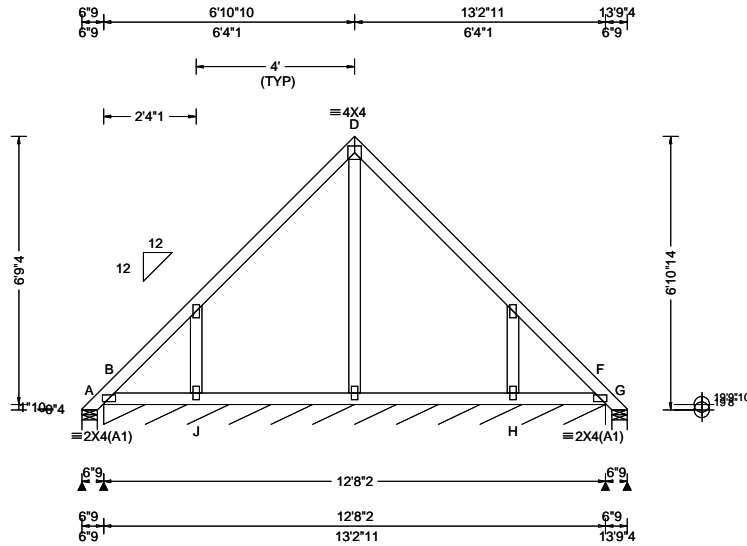

<b>Loading Criteria (psf)</b> TCLL: 20.00 TC DL: 10.00 BCLL: 0.00 BCDL: 10.00 Des Ld: 40.00 NCBCLL: 10.00 Soffit: 2.00 Load Duration: 1.25 Spacing: 24.0 "	<b>Wind Criteria</b> Wind Std: ASCE 7-22 Speed: 130 mph Enclosure: Enclosed Risk Category: II EXP: C Kzt: NA Mean Height: 18.07 ft TC DL: 5.0 psf BCDL: 5.0 psf MWFRS Parallel Dist: 0 to h/2 C&C Dist a: 3.00 ft Loc. from endwall: not in 4.50 ft GCp: 0.18 Wind Duration: 1.60	<b>Snow Criteria (Pg, Pf in PSF)</b> Pg: NA Ct: NA CAT: NA Pf: NA Ce: NA Lu: NA Cs: NA Snow Duration: NA Building Code: FBC 8th Ed. 2023 Res. TPI Std: 2014 Rep Fac: No FT/RT: 20(0)/10(0) Plate Type(s): WAVE	<b>Defl/CSI Criteria</b> PP Deflection in loc L/defl L/# VERT(LL): 0.001 D 999 360 VERT(CL): 0.002 D 999 240 HORZ(LL): 0.000 H - - HORZ(TL): 0.004 E - - Creep Factor: 2.0 Max TC CSI: 0.257 Max BC CSI: 0.084 Max Web CSI: 0.126 VIEW Ver: 24.02.00D.0114.10	<b>▲ Maximum Reactions (lbs), or * = PLF</b> <table border="1"> <thead> <tr> <th rowspan="2">Loc</th> <th colspan="3">Gravity</th> <th colspan="3">Non-Gravity</th> </tr> <tr> <th>R+</th> <th>/R-</th> <th>/Rh</th> <th>/Rw</th> <th>/U</th> <th>/RL</th> </tr> </thead> <tbody> <tr> <td>A</td> <td>39</td> <td>/-</td> <td>/-</td> <td>/190</td> <td>/164</td> <td>/221</td> </tr> <tr> <td>B*</td> <td>87</td> <td>/-</td> <td>/-</td> <td>/65</td> <td>/14</td> <td>/-</td> </tr> <tr> <td>G</td> <td>39</td> <td>/-</td> <td>/-</td> <td>/24</td> <td>/-</td> <td>/-</td> </tr> <tr> <td>J</td> <td></td> <td></td> <td>/-219</td> <td></td> <td></td> <td></td> </tr> <tr> <td>H</td> <td></td> <td></td> <td>/-219</td> <td></td> <td></td> <td></td> </tr> </tbody> </table>	Loc	Gravity			Non-Gravity			R+	/R-	/Rh	/Rw	/U	/RL	A	39	/-	/-	/190	/164	/221	B*	87	/-	/-	/65	/14	/-	G	39	/-	/-	/24	/-	/-	J			/-219				H			/-219			
				Loc		Gravity			Non-Gravity																																											
R+	/R-	/Rh	/Rw		/U	/RL																																														
A	39	/-	/-	/190	/164	/221																																														
B*	87	/-	/-	/65	/14	/-																																														
G	39	/-	/-	/24	/-	/-																																														
J			/-219																																																	
H			/-219																																																	
Wind reactions based on MWFRS A Brg Wid = 4.7 Min Req = 1.5 (Truss) B Brg Wid = 152 Min Req = - G Brg Wid = 4.7 Min Req = 1.5 (Truss) Bearings A, B, & G are a rigid surface. Members not listed have forces less than 375#																																																				

**Lumber**

Top chord: 2x4 SP #2;  
 Bot chord: 2x4 SP #2;  
 Webs: 2x4 SP #3;

**Plating Notes**

All plates are 2X4 except as noted.

**Wind**

Wind loads based on MWFRS with additional C&C member design.  
 Wind loading based on both gable and hip roof types.

**Additional Notes**

Refer to DWG PB160220723 for piggyback details.  
 The overall height of this truss excluding overhang is 6-10-14.

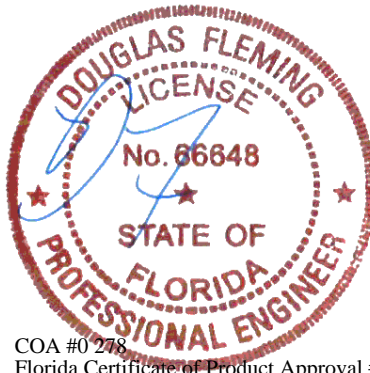

COA #0 278  
 Florida Certificate of Product Approval #FL1999  
 02/25/2026

**\*\*WARNING\*\* READ AND FOLLOW ALL NOTES ON THIS DRAWING!**  
**\*\*IMPORTANT\*\* FURNISH THIS DRAWING TO ALL CONTRACTORS INCLUDING THE INSTALLERS**  
 Trusses require extreme care in fabricating, handling, shipping, installing and bracing. Refer to and follow the latest edition of BCSI (Building Component Safety Information, by TPI and SBCA) for safety practices prior to performing these functions. Installers shall provide temporary bracing per BCSI. Unless noted otherwise, top chord shall have properly attached structural sheathing and bottom chord shall have a properly attached rigid ceiling. Locations shown for permanent lateral restraint of webs shall have continuous lateral restraint (CLR), installed with diagonal bracing installed on the CLR per BCSI sections B3, B7, or B10, as applicable. Apply plates to each face of truss and position as shown above and on the Joint Details, unless noted otherwise. Refer to drawings 160A-Z for standard plate positions. Refer to job's General Notes page for additional information.  
 Alpine, a division of ITW Building Components Group Inc. shall not be responsible for any deviation from this drawing, any failure to build the truss in conformance with ANSI/TPI 1, or for handling, shipping, installation and bracing of trusses. A seal on this drawing or cover page listing this drawing, indicates acceptance of professional engineering responsibility solely for the design shown. The suitability and use of this drawing for any structure is the responsibility of the Building Designer per ANSI/TPI 1 Sec.2.  
 For more information see these web sites: Alpine: alpineitw.com; TPI: tpinst.org; SBCA: sbcacomponents.com; ICC: iccsafe.org; AWC: awc.org



SEQN: 727987 FROM: RFG	GABL Ply: 1 Qty: 1	Job Number: 26-3388d JOHNSON Truss Label: P3E	Cust: R215 JRef: 1YHX2150002 T14 DrwNo: 056.26.0833.52910 JB / DF 02/25/2026
---------------------------	--------------------------	---	--

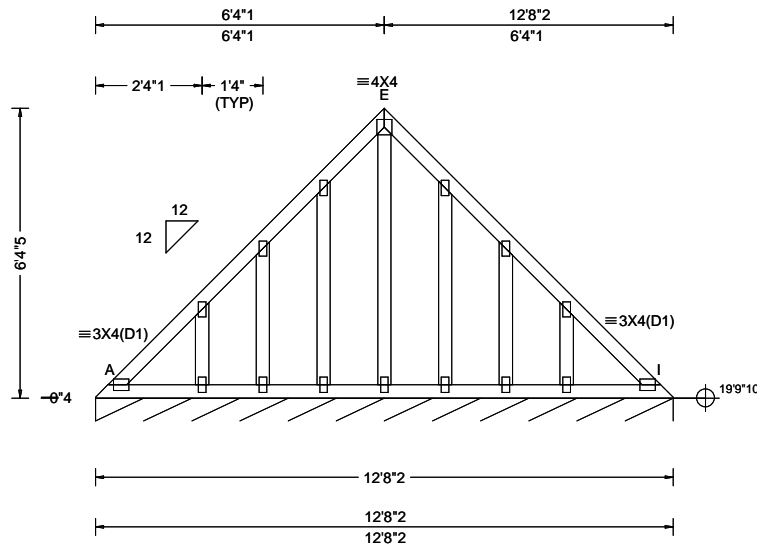

<b>Loading Criteria (psf)</b> TCLL: 20.00 TCDL: 10.00 BCLL: 0.00 BCDL: 10.00 Des Ld: 40.00 NCBCLL: 0.00 Soffit: 2.00 Load Duration: 1.25 Spacing: 24.0 "	<b>Wind Criteria</b> Wind Std: ASCE 7-22 Speed: 130 mph Enclosure: Enclosed Risk Category: II EXP: C Kzt: NA Mean Height: 17.89 ft TCDL: 5.0 psf BCDL: 5.0 psf MWFRS Parallel Dist: 0 to h/2 C&C Dist a: 3.00 ft Loc. from endwall: not in 9.00 ft GCpi: 0.18 Wind Duration: 1.60	<b>Snow Criteria (Pg,Pf in PSF)</b> Pg: NA Ct: NA CAT: NA Pf: NA Ce: NA Lu: NA Cs: NA Snow Duration: NA  Building Code: FBC 8th Ed. 2023 Res. TPI Std: 2014 Rep Fac: Yes FT/RT:20(0)/10(0) Plate Type(s): WAVE	<b>Defl/CSI Criteria</b> PP Deflection in loc L/defl L/# VERT(LL): 0.001 A 999 360 VERT(CL): 0.001 A 999 240 HORZ(LL): -0.001 A - - HORZ(TL): 0.001 C - - Creep Factor: 2.0 Max TC CSI: 0.041 Max BC CSI: 0.037 Max Web CSI: 0.866  VIEW Ver: 24.02.00D.0114.10	<b>▲ Maximum Reactions (lbs), or *=PLF</b> Gravity Non-Gravity Loc R+ / R- / Rh / Rw / U / RL A* 68 /- /- /35 /- /- Wind reactions based on MWFRS A Brg Wid = 152 Min Req = - Bearing A is a rigid surface. Members not listed have forces less than 375#
---	--	--	--	--

**Lumber**

Top chord: 2x4 SP #2;  
Bot chord: 2x4 SP #2;  
Webs: 2x4 SP #3;

**Plating Notes**

All plates are 2X4 except as noted.

**Purlins**

In lieu of structural panels use purlins to brace TC @ 24" oc.

**Wind**

Wind loads based on MWFRS with additional C&C member design.

Wind loading based on both gable and hip roof types.

Gable meets L/120 deflection criteria for wind load applied to face. Calculated deflection ratio is L/171.

**Additional Notes**

Exposed portion of gable face shall be reinforced with sheathing and the wind pressures shall be transferred into lateral diaphragms. Connections and designs for diaphragms is the responsibility of the Building Designer in accordance with ANSI/TPI 1.

Refer to DWG PB160220723 for piggyback details.

The overall height of this truss excluding overhang is 6-5-15.

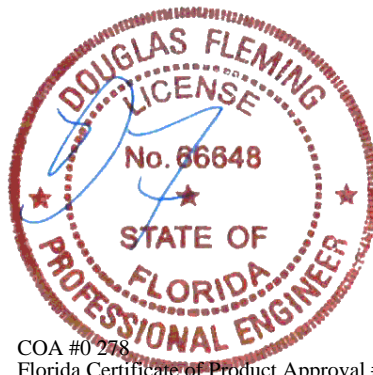

COA #0 278  
Florida Certificate of Product Approval #FL1999  
02/25/2026

**\*\*WARNING\*\* READ AND FOLLOW ALL NOTES ON THIS DRAWING!**  
**\*\*IMPORTANT\*\* FURNISH THIS DRAWING TO ALL CONTRACTORS INCLUDING THE INSTALLERS**  
Trusses require extreme care in fabricating, handling, shipping, installing and bracing. Refer to and follow the latest edition of BCSI (Building Component Safety Information, by TPI and SBCA) for safety practices prior to performing these functions. Installers shall provide temporary bracing per BCSI. Unless noted otherwise, top chord shall have properly attached structural sheathing and bottom chord shall have a properly attached rigid ceiling. Locations shown for permanent lateral restraint of webs shall have continuous lateral restraint (CLR), installed with diagonal bracing installed on the CLR per BCSI sections B3, B7, or B10, as applicable. Apply plates to each face of truss and position as shown above and on the Joint Details, unless noted otherwise. Refer to drawings 160A-Z for standard plate positions. Refer to job's General Notes page for additional information.  
Alpine, a division of ITW Building Components Group Inc. shall not be responsible for any deviation from this drawing, any failure to build the truss in conformance with ANSI/TPI 1, or for handling, shipping, installation and bracing of trusses. A seal on this drawing or cover page listing this drawing, indicates acceptance of professional engineering responsibility solely for the design shown. The suitability and use of this drawing for any structure is the responsibility of the Building Designer per ANSI/TPI 1 Sec.2.  
For more information see these web sites: Alpine: alpineitw.com; TPI: tpinst.org; SBCA: sbcacomponents.com; ICC: iccsafe.org; AWC: awc.org



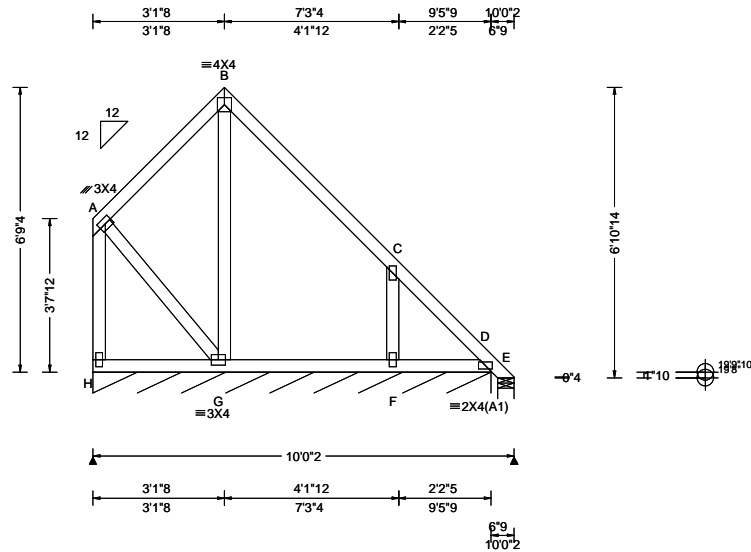

<b>Loading Criteria (psf)</b> TCLL: 20.00 TCDL: 10.00 BCLL: 0.00 BCDL: 10.00 Des Ld: 40.00 NCBCLL: 10.00 Soffit: 2.00 Load Duration: 1.25 Spacing: 24.0 "	<b>Wind Criteria</b> Wind Std: ASCE 7-22 Speed: 130 mph Enclosure: Enclosed Risk Category: II EXP: C Kzt: NA Mean Height: 23.13 ft TCDL: 5.0 psf BCDL: 5.0 psf MWFRS Parallel Dist: h/2 to h C&C Dist a: 3.00 ft Loc. from endwall: not in 9.00 ft GCp: 0.18 Wind Duration: 1.60	<b>Snow Criteria (Pg,Pf in PSF)</b> Pg: NA Ct: NA CAT: NA Pf: NA Ce: NA Lu: NA Cs: NA Snow Duration: NA  Building Code: FBC 8th Ed. 2023 Res. TPI Std: 2014 Rep Fac: No FT/RT:20(0)/10(0) Plate Type(s): WAVE	<b>Defl/CSI Criteria</b> PP Deflection in loc L/defl L/# VERT(LL): 0.001 B 999 360 VERT(CL): 0.002 B 999 240 HORZ(LL): -0.001 A - - HORZ(TL): 0.002 C - - Creep Factor: 2.0 Max TC CSI: 0.316 Max BC CSI: 0.099 Max Web CSI: 0.138  VIEW Ver: 24.02.00D.0114.10	<b>▲ Maximum Reactions (lbs), or *=PLF</b> Gravity Non-Gravity Loc R+ / R- / Rh / Rw / U / RL H* 81 /- /- /58 /18 /22 E 37 /- /- /19 /0 /- Wind reactions based on MWFRS H Brg Wid = 113 Min Req = - E Brg Wid = 4.7 Min Req = 1.5 (Truss) Bearings H & E are a rigid surface. Members not listed have forces less than 375# <b>Maximum Web Forces Per Ply (lbs)</b> Webs Tens.Comp. F - C 430 -276
--	---	---	--	---

**Lumber**

Top chord: 2x4 SP #2;  
Bot chord: 2x4 SP #2;  
Webs: 2x4 SP #3;

**Plating Notes**

All plates are 2X4 except as noted.

**Loading**

Gable end supports 8" max rake overhang. Top chord must not be cut or notched.  
Truss passed check for 20 psf additional bottom chord live load in areas with 42"-high x 24"-wide clearance.

**Wind**

Wind loads based on MWFRS with additional C&C member design.  
Left end vertical not exposed to wind pressure.  
Wind loading based on both gable and hip roof types.

**Additional Notes**

The overall height of this truss excluding overhang is 6-10-14.  
Refer to DWG PB160220723 for piggyback details.

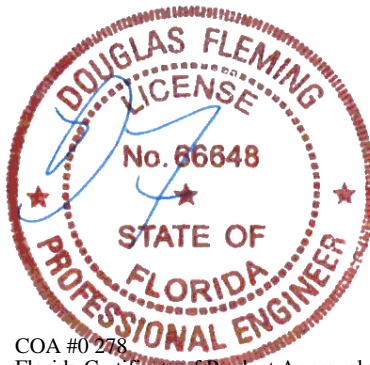

COA #0278  
Florida Certificate of Product Approval #FL1999  
02/25/2026

**\*\*WARNING\*\* READ AND FOLLOW ALL NOTES ON THIS DRAWING!**  
**\*\*IMPORTANT\*\* FURNISH THIS DRAWING TO ALL CONTRACTORS INCLUDING THE INSTALLERS**  
Trusses require extreme care in fabricating, handling, shipping, installing and bracing. Refer to and follow the latest edition of BCSI (Building Component Safety Information, by TPI and SBCA) for safety practices prior to performing these functions. Installers shall provide temporary bracing per BCSI. Unless noted otherwise, top chord shall have properly attached structural sheathing and bottom chord shall have a properly attached rigid ceiling. Locations shown for permanent lateral restraint of webs shall have continuous lateral restraint (CLR), installed with diagonal bracing installed on the CLR per BCSI sections B3, B7, or B10, as applicable. Apply plates to each face of truss and position as shown above and on the Joint Details, unless noted otherwise. Refer to drawings 160A-Z for standard plate positions. Refer to job's General Notes page for additional information.  
Alpine, a division of ITW Building Components Group Inc. shall not be responsible for any deviation from this drawing, any failure to build the truss in conformance with ANSI/TPI 1, or for handling, shipping, installation and bracing of trusses. A seal on this drawing or cover page listing this drawing, indicates acceptance of professional engineering responsibility solely for the design shown. The suitability and use of this drawing for any structure is the responsibility of the Building Designer per ANSI/TPI 1 Sec.2.  
For more information see these web sites: Alpine: [alpineitw.com](http://alpineitw.com); TPI: [tpinst.org](http://tpinst.org); SBCA: [sbcacomponents.com](http://sbcacomponents.com); ICC: [iccsafe.org](http://iccsafe.org); AWC: [awc.org](http://awc.org)



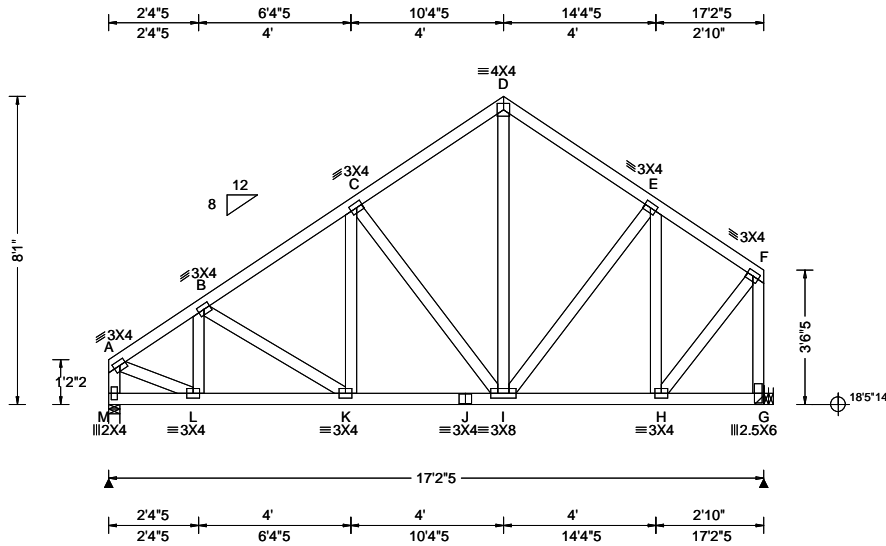

<b>Loading Criteria (psf)</b> TCLL: 20.00 TCDL: 10.00 BCLL: 0.00 BCDL: 10.00 Des Ld: 40.00 NCBCLL: 10.00 Soffit: 2.00 Load Duration: 1.25 Spacing: 24.0 "	<b>Wind Criteria</b> Wind Std: ASCE 7-22 Speed: 130 mph Enclosure: Enclosed Risk Category: II EXP: C Kzt: NA Mean Height: 23.12 ft TCDL: 5.0 psf BCDL: 5.0 psf MWFRS Parallel Dist: h/2 to h C&C Dist a: 3.00 ft Loc. from endwall: not in 9.00 ft GCp: 0.18 Wind Duration: 1.60	<b>Snow Criteria (Pg,Pf in PSF)</b> Pg: NA Ct: NA CAT: NA Pf: NA Ce: NA Lu: NA Cs: NA Snow Duration: NA  Building Code: FBC 8th Ed. 2023 Res. TPI Std: 2014 Rep Fac: Yes FT/RT:20(0)/10(0) Plate Type(s): WAVE	<b>Defl/CSI Criteria</b> PP Deflection in loc L/defl L/# VERT(LL): 0.014 K 999 360 VERT(CL): 0.028 K 999 240 HORZ(LL): 0.005 B - - HORZ(TL): 0.011 B - - Creep Factor: 2.0 Max TC CSI: 0.171 Max BC CSI: 0.210 Max Web CSI: 0.251  VIEW Ver: 24.02.00D.0114.10	<b>▲ Maximum Reactions (lbs)</b> Gravity Non-Gravity Loc R+ / R- / Rh / Rw / U / RL M 722 /- /- /425 /99 /197 G 722 /- /- /400 /119 /- Wind reactions based on MWFRS M Brg Wid = 3.5 Min Req = 1.5 (Truss) G Brg Wid = - Min Req = - Bearing M is a rigid surface. Members not listed have forces less than 375# <b>Maximum Top Chord Forces Per Ply (lbs)</b> Chords Tens.Comp. Chords Tens. Comp. A - B 187 -775 D - E 240 -546 B - C 226 -777 E - F 143 -449 C - D 235 -548  <b>Maximum Bot Chord Forces Per Ply (lbs)</b> Chords Tens.Comp. Chords Tens. Comp. L - K 635 -226 J - I 586 -145 K - J 586 -145  <b>Maximum Web Forces Per Ply (lbs)</b> Webs Tens.Comp. Webs Tens. Comp. A - M 172 -704 H - F 528 -114 A - L 658 -127 F - G 199 -702
--	---	--	---	---

**Lumber**

Top chord: 2x4 SP #2;  
Bot chord: 2x4 SP #2;  
Webs: 2x4 SP #3;

**Wind**

Wind loads based on MWFRS with additional C&C member design.  
End verticals not exposed to wind pressure.  
Wind loading based on both gable and hip roof types.

**Additional Notes**

The overall height of this truss excluding overhang is 8-1-0.

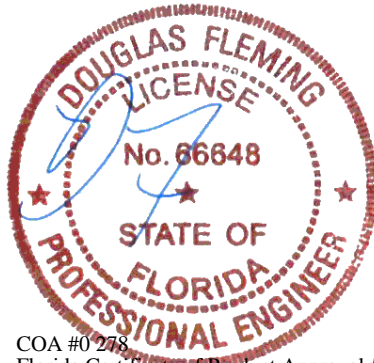

COA #0278  
Florida Certificate of Product Approval #FL1999  
02/25/2026

**\*\*WARNING\*\* READ AND FOLLOW ALL NOTES ON THIS DRAWING!**  
**\*\*IMPORTANT\*\* FURNISH THIS DRAWING TO ALL CONTRACTORS INCLUDING THE INSTALLERS**  
Trusses require extreme care in fabricating, handling, shipping, installing and bracing. Refer to and follow the latest edition of BCSI (Building Component Safety Information, by TPI and SBCA) for safety practices prior to performing these functions. Installers shall provide temporary bracing per BCSI. Unless noted otherwise, top chord shall have properly attached structural sheathing and bottom chord shall have a properly attached rigid ceiling. Locations shown for permanent lateral restraint of webs shall have continuous lateral restraint (CLR), installed with diagonal bracing installed on the CLR per BCSI sections B3, B7, or B10, as applicable. Apply plates to each face of truss and position as shown above and on the Joint Details, unless noted otherwise. Refer to drawings 160A-Z for standard plate positions. Refer to job's General Notes page for additional information.  
Alpine, a division of ITW Building Components Group Inc. shall not be responsible for any deviation from this drawing, any failure to build the truss in conformance with ANSI/TPI 1, or for handling, shipping, installation and bracing of trusses. A seal on this drawing or cover page listing this drawing, indicates acceptance of professional engineering responsibility solely for the design shown. The suitability and use of this drawing for any structure is the responsibility of the Building Designer per ANSI/TPI 1 Sec.2.  
For more information see these web sites: Alpine: alpineitw.com; TPI: tpinst.org; SBCA: sbccomponents.com; ICC: iccsafe.org; AWC: awc.org



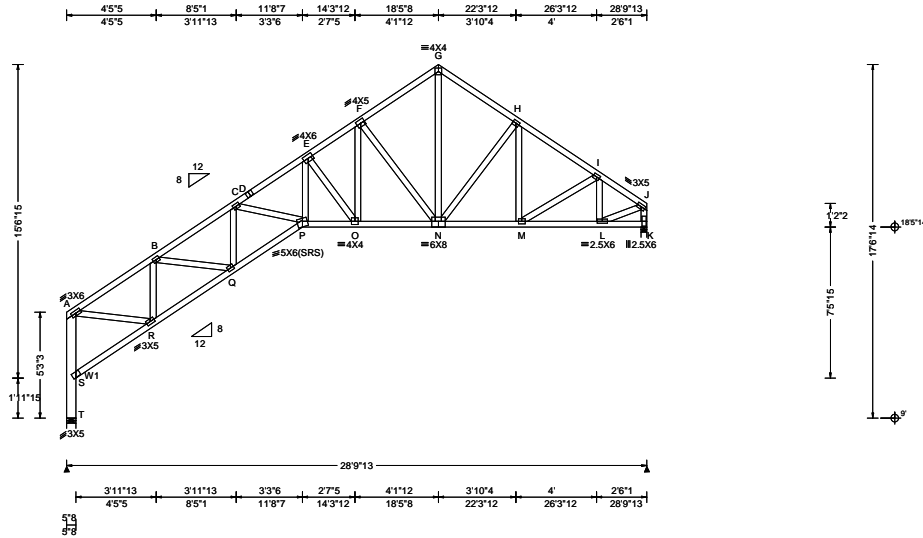

<b>Loading Criteria (psf)</b> TCLL: 20.00 TCDL: 10.00 BCLL: 0.00 BCDL: 10.00 Des Ld: 40.00 NCBCLL: 10.00 Soffit: 2.00 Load Duration: 1.25 Spacing: 24.0 "	<b>Wind Criteria</b> Wind Std: ASCE 7-22 Speed: 130 mph Enclosure: Enclosed Risk Category: II EXP: C Kzt: NA Mean Height: 20.42 ft TCDL: 5.0 psf BCDL: 5.0 psf MWFRS Parallel Dist: h to 2h C&C Dist a: 3.00 ft Loc. from endwall: not in 9.00 ft GCpi: 0.18 Wind Duration: 1.60	<b>Snow Criteria (Pg,Pf in PSF)</b> Pg: NA Ct: NA CAT: NA Pf: NA Ce: NA Lu: NA Cs: NA Snow Duration: NA  Building Code: FBC 8th Ed. 2023 Res. TPI Std: 2014 Rep Fac: Yes FT/RT:20(0)/10(0) Plate Type(s): WAVE	<b>Defl/CSI Criteria</b> PP Deflection in loc L/defl L/# VERT(LL): 0.150 P 999 360 VERT(CL): 0.321 P 999 240 HORZ(LL): 0.152 K - - HORZ(TL): 0.325 K - - Creep Factor: 2.0 Max TC CSI: 0.275 Max BC CSI: 0.655 Max Web CSI: 0.868  VIEW Ver: 24.02.00D.0114.10	<b>▲ Maximum Reactions (lbs)</b> Gravity Non-Gravity Loc R+ / R- / Rh / Rw / U / RL T 1248 -/- /- /718 /12 /346 K 1210 -/- /- /738 /99 /- Wind reactions based on MWFRS T Brg Wid = 5.5 Min Req = 1.5 (Support) K Brg Wid = 3.5 Min Req = 1.5 (Truss) Bearings T & K are a rigid surface. Members not listed have forces less than 375# <b>Maximum Top Chord Forces Per Ply (lbs)</b> Chords Tens.Comp. Chords Tens. Comp. A - B 612 -1692 F - G 473 -1327 B - C 906 -2733 G - H 476 -1330 C - D 979 -3178 H - I 445 -1505 D - E 998 -3152 I - J 351 -1329 E - F 697 -2148
--	---	--	---	--

**Lumber**  
Top chord: 2x4 SP #2;  
Bot chord: 2x4 SP #2;  
Webs: 2x4 SP #3; W1 2x6 SP #2;

**Plating Notes**  
All plates are 3X4 except as noted.

**Wind**  
Wind loads based on MWFRS with additional C&C member design.  
End verticals not exposed to wind pressure.  
Wind loading based on both gable and hip roof types.

**Additional Notes**  
Shim all supports to solid bearing.  
The overall height of this truss excluding overhang is 17-6-14.  
Leg down designed for vertical loads only.

**Maximum Bot Chord Forces Per Ply (lbs)**

Chords	Tens.Comp.	Chords	Tens. Comp.
S - R	552 -748	O - N	1709 -429
R - Q	1772 -815	N - M	1194 -246
Q - P	2697 -964	M - L	1111 -270
P - O	2498 -736		

**Maximum Web Forces Per Ply (lbs)**

Webs	Tens.Comp.	Webs	Tens. Comp.
A - S	419 -1166	E - O	505 -1289
A - R	1431 -303	O - F	1117 -377
S - T	201 -1246	F - N	431 -1085
R - B	308 -1006	G - N	1139 -404
B - Q	834 -123	L - J	1149 -273
Q - C	147 -598	J - K	315 -1189
P - E	1435 -504		

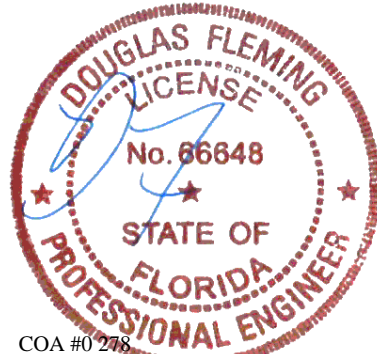

COA #0 278  
Florida Certificate of Product Approval #FL1999  
02/25/2026

**\*\*WARNING\*\* READ AND FOLLOW ALL NOTES ON THIS DRAWING!**  
**\*\*IMPORTANT\*\* FURNISH THIS DRAWING TO ALL CONTRACTORS INCLUDING THE INSTALLERS**  
Trusses require extreme care in fabricating, handling, shipping, installing and bracing. Refer to and follow the latest edition of BCSI (Building Component Safety Information, by TPI and SBCA) for safety practices prior to performing these functions. Installers shall provide temporary bracing per BCSI. Unless noted otherwise, top chord shall have properly attached structural sheathing and bottom chord shall have a properly attached rigid ceiling. Locations shown for permanent lateral restraint of webs shall have continuous lateral restraint (CLR), installed with diagonal bracing installed on the CLR per BCSI sections B3, B7, or B10, as applicable. Apply plates to each face of truss and position as shown above and on the Joint Details, unless noted otherwise. Refer to drawings 160A-Z for standard plate positions. Refer to job's General Notes page for additional information.  
Alpine, a division of ITW Building Components Group Inc. shall not be responsible for any deviation from this drawing, any failure to build the truss in conformance with ANSI/TPI 1, or for handling, shipping, installation and bracing of trusses. A seal on this drawing or cover page listing this drawing, indicates acceptance of professional engineering responsibility solely for the design shown. The suitability and use of this drawing for any structure is the responsibility of the Building Designer per ANSI/TPI 1 Sec.2.  
For more information see these web sites: Alpine: alpineitw.com; TPI: tpinst.org; SBCA: sbccomponents.com; ICC: iccsafe.org; AWC: awc.org



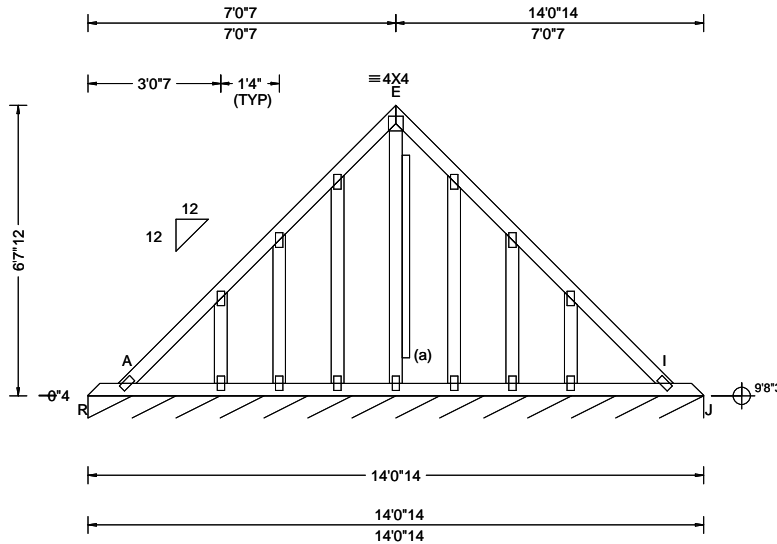

<b>Loading Criteria (psf)</b> TCLL: 20.00 TCDL: 10.00 BCLL: 0.00 BCDL: 10.00 Des Ld: 40.00 NCBCLL: 10.00 Soffit: 2.00 Load Duration: 1.25 Spacing: 24.0 "	<b>Wind Criteria</b> Wind Std: ASCE 7-22 Speed: 130 mph Enclosure: Enclosed Risk Category: II EXP: C Kzt: NA Mean Height: 15.00 ft TCDL: 5.0 psf BCDL: 5.0 psf MWFRS Parallel Dist: 0 to h/2 C&C Dist a: 3.00 ft Loc. from endwall: Any GCpi: 0.18 Wind Duration: 1.60	<b>Snow Criteria (Pg,Pf in PSF)</b> Pg: NA Ct: NA CAT: NA Pf: NA Ce: NA Lu: NA Cs: NA Snow Duration: NA  Building Code: FBC 8th Ed. 2023 Res. TPI Std: 2014 Rep Fac: Varies by Ld Case FT/RT:20(0)/10(0) Plate Type(s): WAVE	<b>Defl/CSI Criteria</b> PP Deflection in loc L/defl L/# VERT(LL): 0.001 D 999 360 VERT(CL): 0.002 D 999 240 HORZ(LL): -0.000 F - - HORZ(TL): 0.005 D - - Creep Factor: 2.0 Max TC CSI: 0.103 Max BC CSI: 0.057 Max Web CSI: 0.771  VIEW Ver: 24.02.00D.0114.10	<b>▲ Maximum Reactions (lbs), or *=PLF</b> Gravity Non-Gravity Loc R+ / R- / Rh / Rw / U / RL J* 127 /- /- /59 /16 /20 Wind reactions based on MWFRS J Brg Wid = 168 Min Req = - Bearing R is a rigid surface. Members not listed have forces less than 375#
--	---	--	--	---

**Lumber**  
Top chord: 2x4 SP #2;  
Bot chord: 2x4 SP #2;  
Webs: 2x4 SP #3;

**Plating Notes**  
All plates are 2X4 except as noted.

**Loading**  
Truss designed to support 1-4-0 top chord outlookers and cladding load not to exceed 5.00 PSF one face and 24.0" span opposite face. Top chord must not be cut or notched, unless specified otherwise.

**Wind**  
Wind loads based on MWFRS with additional C&C member design.  
Wind loading based on both gable and hip roof types.  
Gable meets L/120 deflection criteria for wind load applied to face. Calculated deflection ratio is L/312.

**Gable Reinforcement**  
(a) 2x4 "L" reinforcement. Any species and grade. 80% length of web member. Attach with 10d (0.131"x3",min.) nails @ 2" oc at each end for the first 18" and then 4" oc for the remainder.

**Additional Notes**  
Exposed portion of gable face shall be reinforced with sheathing and the wind pressures shall be transferred into lateral diaphragms. Connections and designs for diaphragms is the responsibility of the Building Designer in accordance with ANSI/TPI 1.  
The overall height of this truss excluding overhang is 6-7-12.

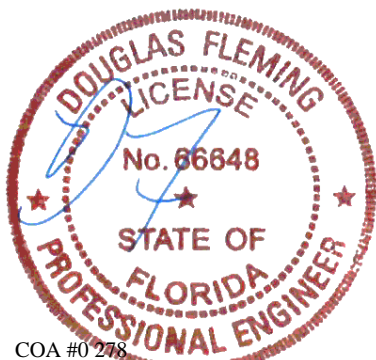

COA #0 278  
Florida Certificate of Product Approval #FL1999  
02/25/2026

**\*\*WARNING\*\* READ AND FOLLOW ALL NOTES ON THIS DRAWING!**  
**\*\*IMPORTANT\*\* FURNISH THIS DRAWING TO ALL CONTRACTORS INCLUDING THE INSTALLERS**  
Trusses require extreme care in fabricating, handling, shipping, installing and bracing. Refer to and follow the latest edition of BCSI (Building Component Safety Information, by TPI and SBCA) for safety practices prior to performing these functions. Installers shall provide temporary bracing per BCSI. Unless noted otherwise, top chord shall have properly attached structural sheathing and bottom chord shall have a properly attached rigid ceiling. Locations shown for permanent lateral restraint of webs shall have continuous lateral restraint (CLR), installed with diagonal bracing installed on the CLR per BCSI sections B3, B7, or B10, as applicable. Apply plates to each face of truss and position as shown above and on the Joint Details, unless noted otherwise. Refer to drawings 160A-Z for standard plate positions. Refer to job's General Notes page for additional information.  
Alpine, a division of ITW Building Components Group Inc. shall not be responsible for any deviation from this drawing, any failure to build the truss in conformance with ANSI/TPI 1, or for handling, shipping, installation and bracing of trusses. A seal on this drawing or cover page listing this drawing, indicates acceptance of professional engineering responsibility solely for the design shown. The suitability and use of this drawing for any structure is the responsibility of the Building Designer per ANSI/TPI 1 Sec.2.  
For more information see these web sites: Alpine: alpineitw.com; TPI: tpinst.org; SBCA: sbccomponents.com; ICC: iccsafe.org; AWC: awc.org



SEQN: 728012 FROM: RFG	VAL Ply: 1 Qty: 1	Job Number: 26-3388d JOHNSON Truss Label: V2	Cust: R 215 JRef: 1YHX2150002 T32 DrwNo: 056.26.0833.10890 JB / DF 02/25/2026
---------------------------	-------------------------	--	---

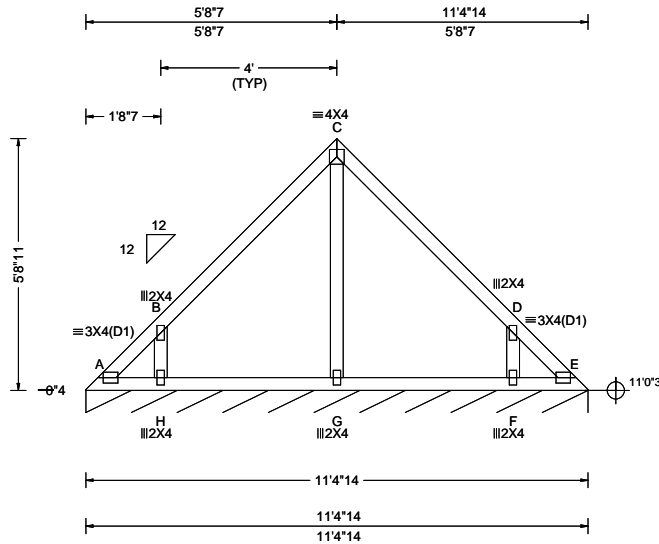

<b>Loading Criteria (psf)</b> TCLL: 20.00 TCDL: 10.00 BCLL: 0.00 BCDL: 10.00 Des Ld: 40.00 NCBCLL: 10.00 Soffit: 2.00 Load Duration: 1.25 Spacing: 24.0 "	<b>Wind Criteria</b> Wind Std: ASCE 7-22 Speed: 130 mph Enclosure: Enclosed Risk Category: II EXP: C Kzt: NA Mean Height: 15.00 ft TCDL: 5.0 psf BCDL: 5.0 psf MWFRS Parallel Dist: 0 to h/2 C&C Dist a: 3.00 ft Loc. from endwall: Any GCp: 0.18 Wind Duration: 1.60	<b>Snow Criteria (Pg,Pf in PSF)</b> Pg: NA Ct: NA CAT: NA Pf: NA Ce: NA Lu: NA Cs: NA Snow Duration: NA  Building Code: FBC 8th Ed. 2023 Res. TPI Std: 2014 Rep Fac: Yes FT/RT:20(0)/10(0) Plate Type(s): WAVE	<b>Defl/CSI Criteria</b> PP Deflection in loc L/defl L/# VERT(LL): 0.001 C 999 360 VERT(CL): 0.001 C 999 240 HORZ(LL): -0.001 A - - HORZ(TL): 0.002 B - - Creep Factor: 2.0 Max TC CSI: 0.315 Max BC CSI: 0.120 Max Web CSI: 0.151  VIEW Ver: 24.02.00D.0114.10	<b>▲ Maximum Reactions (lbs), or *=PLF</b> Gravity Non-Gravity Loc R+ /R- /Rh /Rw /U /RL E* 88 /- /- /50 /10 /15 Wind reactions based on MWFRS E Brg Wid = 136 Min Req = - Bearing A is a rigid surface. Members not listed have forces less than 375# <b>Maximum Web Forces Per Ply (lbs)</b> Webs Tens.Comp. Webs Tens. Comp. B - H 508 -286 F - D 508 -286
--	--	--	--	---

**Lumber**

Top chord: 2x4 SP #2;  
Bot chord: 2x4 SP #2;  
Webs: 2x4 SP #3;

**Wind**

Wind loads based on MWFRS with additional C&C member design.  
Wind loading based on both gable and hip roof types.

**Additional Notes**

See DWGS VALTN220723 and VAL180220723 for valley details.  
The overall height of this truss excluding overhang is 5-8-11.

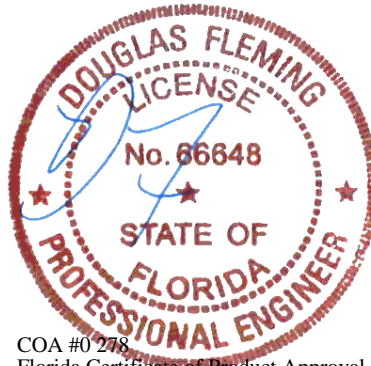

COA #0278  
Florida Certificate of Product Approval #FL1999  
02/25/2026

**\*\*WARNING\*\* READ AND FOLLOW ALL NOTES ON THIS DRAWING!**  
**\*\*IMPORTANT\*\* FURNISH THIS DRAWING TO ALL CONTRACTORS INCLUDING THE INSTALLERS**  
Trusses require extreme care in fabricating, handling, shipping, installing and bracing. Refer to and follow the latest edition of BCSI (Building Component Safety Information, by TPI and SBCA) for safety practices prior to performing these functions. Installers shall provide temporary bracing per BCSI. Unless noted otherwise, top chord shall have properly attached structural sheathing and bottom chord shall have a properly attached rigid ceiling. Locations shown for permanent lateral restraint of webs shall have continuous lateral restraint (CLR), installed with diagonal bracing installed on the CLR per BCSI sections B3, B7, or B10, as applicable. Apply plates to each face of truss and position as shown above and on the Joint Details, unless noted otherwise. Refer to drawings 160A-Z for standard plate positions. Refer to job's General Notes page for additional information.  
Alpine, a division of ITW Building Components Group Inc. shall not be responsible for any deviation from this drawing, any failure to build the truss in conformance with ANSI/TPI 1, or for handling, shipping, installation and bracing of trusses. A seal on this drawing or cover page listing this drawing, indicates acceptance of professional engineering responsibility solely for the design shown. The suitability and use of this drawing for any structure is the responsibility of the Building Designer per ANSI/TPI 1 Sec.2.  
For more information see these web sites: Alpine: [alpineitw.com](http://alpineitw.com); TPI: [tpinst.org](http://tpinst.org); SBCA: [sbcacomponents.com](http://sbcacomponents.com); ICC: [iccsafe.org](http://iccsafe.org); AWC: [awc.org](http://awc.org)



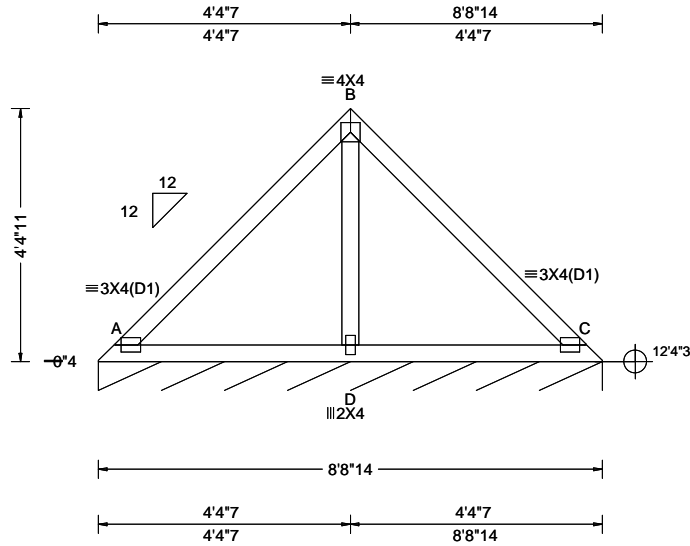

<b>Loading Criteria (psf)</b> TCCL: 20.00 TCDL: 10.00 BCLL: 0.00 BCDL: 10.00 Des Ld: 40.00 NCBCLL: 10.00 Soffit: 2.00 Load Duration: 1.25 Spacing: 24.0 "	<b>Wind Criteria</b> Wind Std: ASCE 7-22 Speed: 130 mph Enclosure: Enclosed Risk Category: II EXP: C Kzt: NA Mean Height: 15.00 ft TCCL: 5.0 psf BCDL: 5.0 psf MWFRS Parallel Dist: 0 to h/2 C&C Dist a: 3.00 ft Loc. from endwall: not in 4.50 ft GCp: 0.18 Wind Duration: 1.60	<b>Snow Criteria (Pg,Pf in PSF)</b> Pg: NA Ct: NA CAT: NA Pf: NA Ce: NA Lu: NA Cs: NA Snow Duration: NA Building Code: FBC 8th Ed. 2023 Res. TPI Std: 2014 Rep Fac: Yes FT/RT:20(0)/10(0) Plate Type(s): WAVE	<b>Defl/CSI Criteria</b> PP Deflection in loc L/defl L/# VERT(LL): 0.011 A 999 360 VERT(CL): 0.015 A 999 240 HORZ(LL): -0.007 C - - HORZ(TL): 0.012 C - - Creep Factor: 2.0 Max TC CSI: 0.348 Max BC CSI: 0.236 Max Web CSI: 0.142 VIEW Ver: 24.02.00D.0114.10	<b>▲ Maximum Reactions (lbs), or *PLF</b> <table border="1"> <thead> <tr> <th colspan="3">Gravity</th> <th colspan="3">Non-Gravity</th> </tr> <tr> <th>Loc</th> <th>R+</th> <th>/R-</th> <th>/Rh</th> <th>/Rw</th> <th>/U</th> <th>/RL</th> </tr> </thead> <tbody> <tr> <td>C*</td> <td>88</td> <td>/-</td> <td>/-</td> <td>/50</td> <td>/9</td> <td>/14</td> </tr> </tbody> </table> Wind reactions based on MWFRS C Brg Wid = 104 Min Req = - Bearing A is a rigid surface. Members not listed have forces less than 375# <b>Maximum Web Forces Per Ply (lbs)</b> <table border="1"> <thead> <tr> <th>Webs</th> <th>Tens.Comp.</th> </tr> </thead> <tbody> <tr> <td>B - D</td> <td>351 -421</td> </tr> </tbody> </table>	Gravity			Non-Gravity			Loc	R+	/R-	/Rh	/Rw	/U	/RL	C*	88	/-	/-	/50	/9	/14	Webs	Tens.Comp.	B - D	351 -421
Gravity			Non-Gravity																									
Loc	R+	/R-	/Rh	/Rw	/U	/RL																						
C*	88	/-	/-	/50	/9	/14																						
Webs	Tens.Comp.																											
B - D	351 -421																											

**Lumber**

Top chord: 2x4 SP #2;  
 Bot chord: 2x4 SP #2;  
 Webs: 2x4 SP #3;

**Wind**

Wind loads based on MWFRS with additional C&C member design.  
 Wind loading based on both gable and hip roof types.

**Additional Notes**

See DWGS VALTN220723 and VAL180220723 for valley details.  
 The overall height of this truss excluding overhang is 4-4-11.

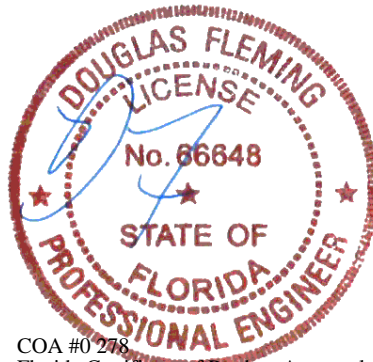

COA #0278  
 Florida Certificate of Product Approval #FL1999  
 02/25/2026

**\*\*WARNING\*\* READ AND FOLLOW ALL NOTES ON THIS DRAWING!**  
**\*\*IMPORTANT\*\* FURNISH THIS DRAWING TO ALL CONTRACTORS INCLUDING THE INSTALLERS**  
 Trusses require extreme care in fabricating, handling, shipping, installing and bracing. Refer to and follow the latest edition of BCSI (Building Component Safety Information, by TPI and SBCA) for safety practices prior to performing these functions. Installers shall provide temporary bracing per BCSI. Unless noted otherwise, top chord shall have properly attached structural sheathing and bottom chord shall have a properly attached rigid ceiling. Locations shown for permanent lateral restraint of webs shall have continuous lateral restraint (CLR), installed with diagonal bracing installed on the CLR per BCSI sections B3, B7, or B10, as applicable. Apply plates to each face of truss and position as shown above and on the Joint Details, unless noted otherwise. Refer to drawings 160A-Z for standard plate positions. Refer to job's General Notes page for additional information.  
 Alpine, a division of ITW Building Components Group Inc. shall not be responsible for any deviation from this drawing, any failure to build the truss in conformance with ANSI/TPI 1, or for handling, shipping, installation and bracing of trusses. A seal on this drawing or cover page listing this drawing, indicates acceptance of professional engineering responsibility solely for the design shown. The suitability and use of this drawing for any structure is the responsibility of the Building Designer per ANSI/TPI 1 Sec.2.  
 For more information see these web sites: Alpine: alpineitw.com; TPI: tpinst.org; SBCA: sbccomponents.com; ICC: iccsafe.org; AWC: awc.org





SEQN: 728018 FROM: RFG	VAL Ply: 1 Qty: 1	Job Number: 26-3388d JOHNSON Truss Label: V5	Cust: R215 JRef: 1YHX2150002 T37 DrwNo: 056.26.0833.04110 JB / DF 02/25/2026
---------------------------	-------------------------	--	--

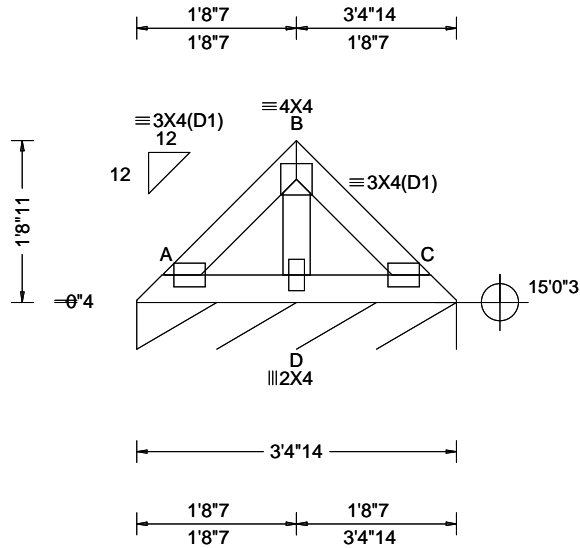

<b>Loading Criteria (psf)</b> TCLL: 20.00 TCDL: 10.00 BCLL: 0.00 BCDL: 10.00 Des Ld: 40.00 NCBCLL: 10.00 Soffit: 2.00 Load Duration: 1.25 Spacing: 24.0 "	<b>Wind Criteria</b> Wind Std: ASCE 7-22 Speed: 130 mph Enclosure: Enclosed Risk Category: II EXP: C Kzt: NA Mean Height: 16.03 ft TCDL: 5.0 psf BCDL: 5.0 psf MWFRS Parallel Dist: h/2 to h C&C Dist a: 3.00 ft Loc. from endwall: not in 9.00 ft GCp: 0.18 Wind Duration: 1.60	<b>Snow Criteria (Pg,Pf in PSF)</b> Pg: NA Ct: NA CAT: NA Pf: NA Ce: NA Lu: NA Cs: NA Snow Duration: NA  Building Code: FBC 8th Ed. 2023 Res. TPI Std: 2014 Rep Fac: Yes FT/RT:20(0)/10(0) Plate Type(s): WAVE	<b>Defl/CSI Criteria</b> PP Deflection in loc L/defl L/# VERT(LL): 0.000 A 999 360 VERT(CL): 0.001 A 999 240 HORZ(LL): -0.000 C - - HORZ(TL): 0.001 C - - Creep Factor: 2.0 Max TC CSI: 0.045 Max BC CSI: 0.029 Max Web CSI: 0.029  VIEW Ver: 24.02.00D.0114.10	<b>▲ Maximum Reactions (lbs), or *=PLF</b> Gravity Non-Gravity Loc R+ / R- / Rh / Rw / U / RL C* 87 /- /- /46 /5 /12 Wind reactions based on MWFRS C Brg Wid = 40.9 Min Req = - Bearing A is a rigid surface. Members not listed have forces less than 375#
--	---	--	--	--

**Lumber**

Top chord: 2x4 SP #2;  
Bot chord: 2x4 SP #2;  
Webs: 2x4 SP #3;

**Wind**

Wind loads based on MWFRS with additional C&C member design.  
Wind loading based on both gable and hip roof types.

**Additional Notes**

See DWGS VALTN220723 and VAL180220723 for valley details.  
The overall height of this truss excluding overhang is 1-8-11.

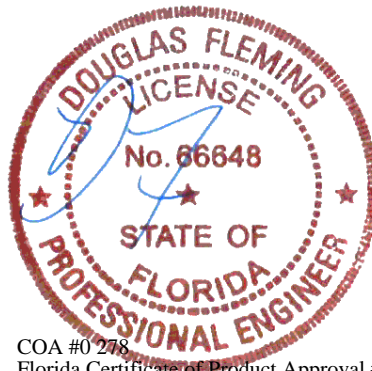

COA #0278  
Florida Certificate of Product Approval #FL1999  
02/25/2026

**\*\*WARNING\*\* READ AND FOLLOW ALL NOTES ON THIS DRAWING!**  
**\*\*IMPORTANT\*\* FURNISH THIS DRAWING TO ALL CONTRACTORS INCLUDING THE INSTALLERS**  
Trusses require extreme care in fabricating, handling, shipping, installing and bracing. Refer to and follow the latest edition of BCSI (Building Component Safety Information, by TPI and SBCA) for safety practices prior to performing these functions. Installers shall provide temporary bracing per BCSI. Unless noted otherwise, top chord shall have properly attached structural sheathing and bottom chord shall have a properly attached rigid ceiling. Locations shown for permanent lateral restraint of webs shall have continuous lateral restraint (CLR), installed with diagonal bracing installed on the CLR per BCSI sections B3, B7, or B10, as applicable. Apply plates to each face of truss and position as shown above and on the Joint Details, unless noted otherwise. Refer to drawings 160A-Z for standard plate positions. Refer to job's General Notes page for additional information.  
Alpine, a division of ITW Building Components Group Inc. shall not be responsible for any deviation from this drawing, any failure to build the truss in conformance with ANSI/TPI 1, or for handling, shipping, installation and bracing of trusses. A seal on this drawing or cover page listing this drawing, indicates acceptance of professional engineering responsibility solely for the design shown. The suitability and use of this drawing for any structure is the responsibility of the Building Designer per ANSI/TPI 1 Sec.2.  
For more information see these web sites: Alpine: [alpineitw.com](http://alpineitw.com); TPI: [tpinst.org](http://tpinst.org); SBCA: [sbcacomponents.com](http://sbcacomponents.com); ICC: [iccsafe.org](http://iccsafe.org); AWC: [awc.org](http://awc.org)



# CLR Reinforcing Member Substitution

This detail is to be used for ANSI/TPI 1-2014 standards and older when a Continuous Lateral Restraint (CLR) is specified on a truss design and an alternative web reinforcement method is desired.

## Notes:

This detail is only applicable for changing the specified CLR shown on single ply sealed designs to T-reinforcement or L-reinforcement or scab reinforcement.

Alternative reinforcement specified in chart below may be conservative. For minimum alternative reinforcement, re-run design with appropriate reinforcement type.

Use scabs instead of L- or T- reinforcement on webs with intersecting truss joints, such as K-web joints, that may interfere with proper application along the narrow face of the web.

Web Member Size	Specified CLR Restraint	Alternative Reinforcement T- or L- Reinf.	Scab Reinf.
2x3 or 2x4	1 row	2x4	1-2x4
2x3 or 2x4	2 rows	2x6	2-2x4
2x6	1 row	2x4	1-2x6
2x6	2 rows	2x6	2-2x4(*)
2x8	1 row	2x6	1-2x8
2x8	2 rows	2x6	2-2x6(*)

T-reinforcement, L-reinforcement, or scab reinforcement to be same species and grade or better than web member unless specified otherwise on Engineer's sealed design.

(\*) Center scab on wide face of web. Apply (1) scab to each face of web.

## T-Reinforcement or L-Reinforcement:

Apply to either side of web narrow face. Attach with 10d (0.131"x3.0",min) nails at 6" o.c. Reinforcing member is a minimum 80% of web member length.

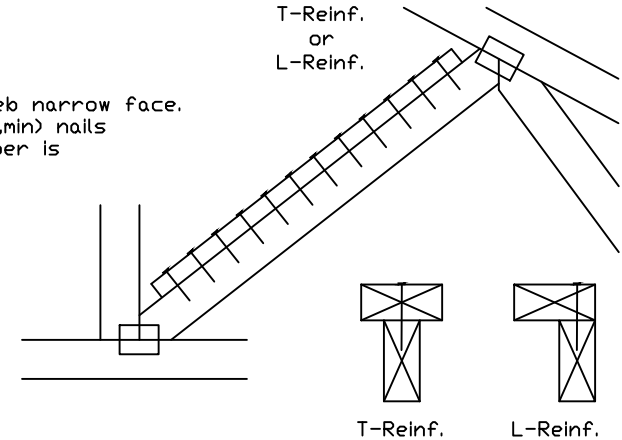

## Scab Reinforcement:

Apply scab(s) to wide face of web. No more than (1) scab per face. Attach with 10d (0.131"x3.0",min) nails at 6" o.c. Reinforcing member is a minimum 80% of web member length.

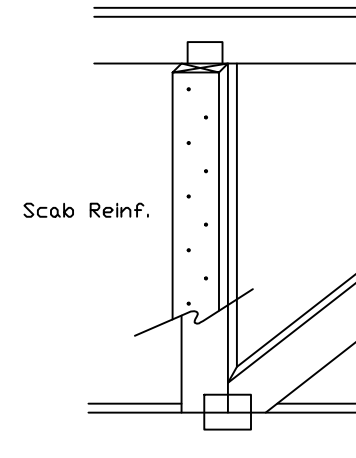

Rev: 01/23/26



155 Harlem Ave  
North Building, 4th Floor  
Glenview, IL 60025

**WARNING: READ AND FOLLOW ALL NOTES ON THIS DRAWING**  
**IMPORTANT: FURNISH THIS DRAWING TO ALL CONTRACTORS INCLUDING THE INSTALLER**  
 Trusses require extreme care in fabricating, handling, shipping, installing and bracing. Refer to and follow the latest edition of BCSI (Building Component Safety Information, by TPI and SBCA) for safety practices prior to performing these functions. Installers shall provide temporary bracing per BCSI. Unless noted otherwise, top chord shall have properly attached structural sheathing and bottom chord shall have a properly attached rigid ceiling. Locations shown for permanent lateral restraint of webs shall have bracing installed per BCSI sections B3, B7 or B10, as applicable. Apply plates to each face of truss and position as shown above and on the Joint Details, unless noted otherwise. Refer to drawings 160A-Z for standard plate positions.  
 Alpine, a division of ITW Building Components Group Inc. shall not be responsible for any deviation from this drawing, any failure to build the truss in conformance with ANSI/TPI 1, or for handling, shipping, installation & bracing of trusses.  
 A seal on this drawing or cover page listing this drawing, indicates acceptance of professional engineering responsibility solely for the design shown. The suitability and use of this drawing for any structure is the responsibility of the Building Designer per ANSI/TPI 1 Sec.2.  
 For more information see this job's general notes page and these web sites:  
 ALPINE: [www.alpineitw.com](http://www.alpineitw.com); TPI: [www.tpinst.org](http://www.tpinst.org); SBCA: [www.sbcacomponents.com](http://www.sbcacomponents.com); ICC: [www.iccsafe.org](http://www.iccsafe.org)

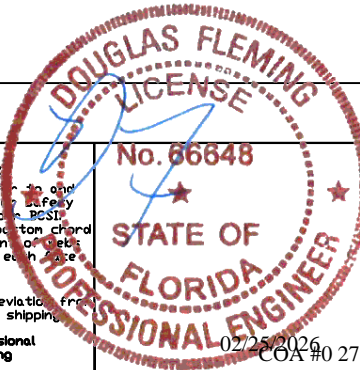

TC LL	PSF	REF CLR Subst.
TC DL	PSF	DATE 01/02/19
BC DL	PSF	DRWG BRCLBSUB0119
BC LL	PSF	
TOT. LD.	PSF	
DUR. FAC.		
SPACING		

# Valley Detail - ASCE 7-22: 180 mph, 30' Mean Height, Partially Enclosed, Exp. C, Kzt=1.00

Top Chord 2x4 SP #2N, SPF #1/#2, DF-L #2 or better.  
 Bot Chord 2x4 SP #2N or SPF #1/#2 or better.  
 Webs 2x4 SP #3, SPF #1/#2, DF-L #2 or better.

\*\* Attach each valley to every supporting truss with:  
 535# connection or with (1) Simpson H2.5A or equivalent connector for  
 ASCE 7-22 180 mph. 30' Mean Height, Part. Enc. Building, Exp. C, Wind TC DL=5 psf, Kzt = 1.00  
 Or  
 ASCE 7-22 160 mph. 30' Mean Height, Part. Enc. Building, Exp. D, Wind TC DL=5 psf, Kzt = 1.00

Bottom chord may be square or pitched cut as shown.

Valleys short enough to be cut as solid triangular members from a single 2x6, or larger as required, shall be permitted in lieu of fabricating from separate 2x4 members.

All plates shown are Alpine Wave Plates.

Unless specified otherwise on engineer's sealed design, for vertical valley webs taller than 7'-9" apply 2x4 "T" reinforcement, 80% length of web, same species and grade or better, attached with 10d box (0.131" x 3.0") nails at 6" o.c. In lieu of "T" reinforcement, 2x4 Continuous Lateral Restraint applied at mid-length of web is permitted with diagonal bracing as shown in DRWG BRCLBANC1014.

Top chord of truss beneath valley set must be braced with properly attached, rated sheathing applied prior to valley truss installation.

Or  
 Purlins at 24" o.c. or as otherwise specified on engineer's sealed design  
 Or  
 By valley trusses used in lieu of purlin spacing as specified on Engineer's sealed design.

\*\*\* Note that the purlin spacing for bracing the top chord of the truss beneath the valley is measured along the slope of the top chord.

++ Larger spans may be built as long as the vertical height does not exceed 14'-0".

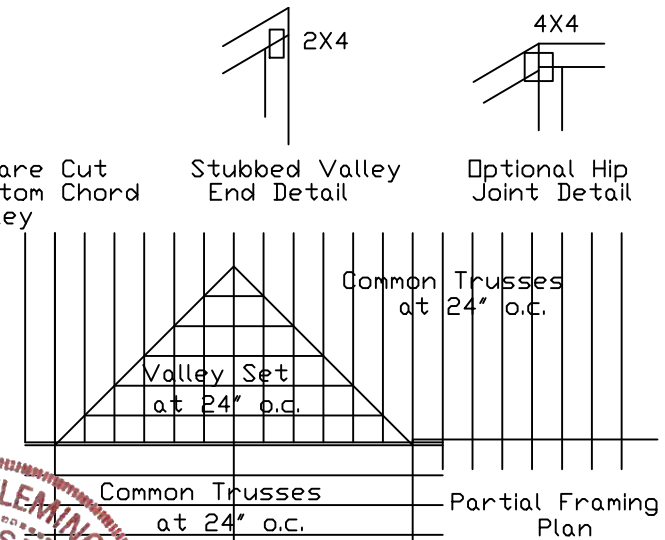
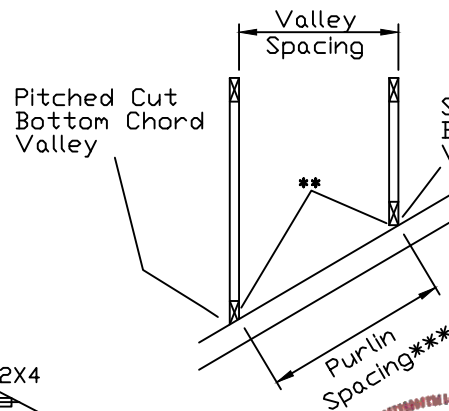
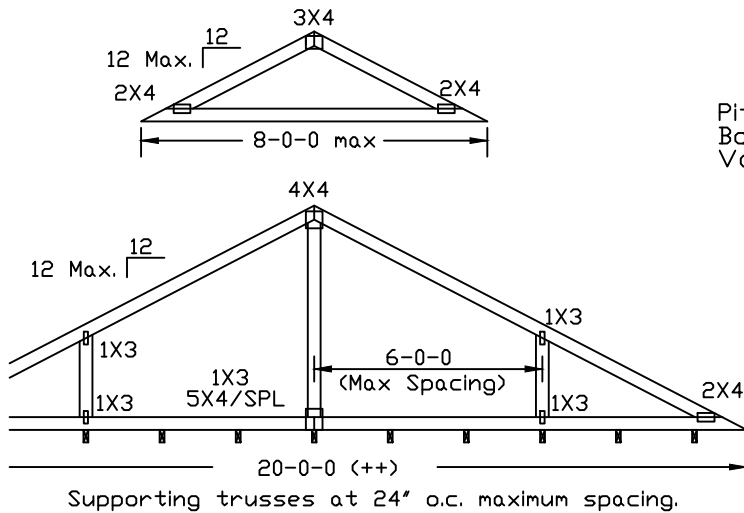

Rev: 01/23/26



**WARNING: READ AND FOLLOW ALL NOTES ON THIS DRAWING**  
**IMPORTANT: FURNISH THIS DRAWING TO ALL CONTRACTORS INCLUDING THE INSTALLERS.**  
 Trusses require extreme care in fabricating, handling, shipping, installing and bracing. Refer to and follow the latest edition of BCSI (Building Component Safety Information, by TPI and SBCA) for safety practices prior to performing these functions. Installers shall provide temporary bracing per BCSI. Unless noted otherwise, top chord shall have properly attached structural sheathing and bottom chord shall have a properly attached rigid ceiling. Locations shown for permanent lateral restraint of webs shall have bracing installed per BCSI sections B3, B7 or B10, as applicable. Apply plates to each face of truss and position as shown above and on the Joint Details, unless noted otherwise. Refer to drawings 160A-Z for standard plate positions.  
 Alpine, a division of ITW Building Components Group Inc. shall not be responsible for any deviation from this drawing, any failure to build the truss in conformance with ANSI/TPI 1, or for handling, shipping, installation & bracing of trusses.  
 A seal on this drawing or cover page listing this drawing, indicates acceptance of professional engineering responsibility solely for the design shown. The suitability and use of this drawing for any structure is the responsibility of the Building Designer per ANSI/TPI 1 Sec.2.  
 For more information see this job's general notes page and these web sites:  
 ALPINE: [www.alpinetw.com](http://www.alpinetw.com) TPI: [www.tpinet.org](http://www.tpinet.org) SBCA: [www.sbccomponents.com](http://www.sbccomponents.com) ICC: [www.iccsafe.org](http://www.iccsafe.org)

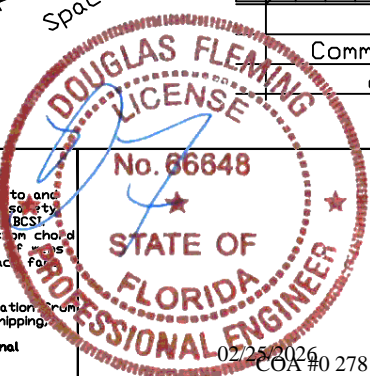

TC LL	30	30	40PSF	REF	VALLEY DETAIL
TC DL	20	15	7PSF	DATE	07/03/2023
BC DL	10	10	10 PSF	DRWG	VAL180220723
BC LL	0	0	0PSF		
TOT. LD.	60	55	57PSF		
DUR.FAC.	1.25/1.33	1.15	1.15		
SPACING	24.0"				

# Valley Detail - ASCE 7-22: 30' Mean Height, Enclosed, Exp. C, Kzt=1.00

Top Chord 2x4 SP #2N, SPF #1/#2, DF-L #2 or better.  
 Bot Chord 2x4 SP #2N or SPF #1/#2 or better.  
 Webs 2x4 SP #3, SPF #1/#2, DF-L #2 or better.

**\*\* Attach each valley to every supporting truss with:**  
 (2) 16d box (0.135" x 3.5") nails toe-nailed for  
 ASCE 7-22, 30' Mean Height, Enclosed Building, Exp. C,  
 Wind TC DL=5 psf, Kzt = 1.00, Max. Wind Speed based on  
 supporting truss material at connection location:  
 140 mph for SP (G = 0.55, min.),  
 125 mph for DF-L (G = 0.50, min.), or  
 105 mph for HF & SPF (G = 0.42, min.).

Maximum top chord pitch is 10/12 for supporting trusses below valley trusses.

Bottom chord of valley trusses may be square or pitched cut as shown.

Valleys short enough to be cut as solid triangular members from a single 2x6, or larger as required, shall be permitted in lieu of fabricating from separate 2x4 members.

All plates shown are Alpine Wave Plates.

Unless specified otherwise on engineer's sealed design, for vertical valley webs taller than 7-9" apply 2x4 "T" reinforcement, 80% length of web, same species and grade or better, attached with 10d box (0.131" x 3.0") nails at 6" o.c. In lieu of "T" reinforcement, 2x4 Continuous Lateral Restraint applied at mid-length of web is permitted with diagonal bracing as shown in DRWG BRCLBANC1014.

Top chord of truss beneath valley set must be braced with: properly attached, rated sheathing applied prior to valley truss installation.

- Purlins at 24" o.c. or as otherwise specified on engineer's sealed design
- By valley trusses used in lieu of purlin spacing as specified on Engineer's sealed design.

**\*\*\* Note that the purlin spacing for bracing the top chord of the truss beneath the valley is measured along the slope of the top chord.**

**++ Larger spans may be built as long as the vertical height does not exceed 14'-0".**

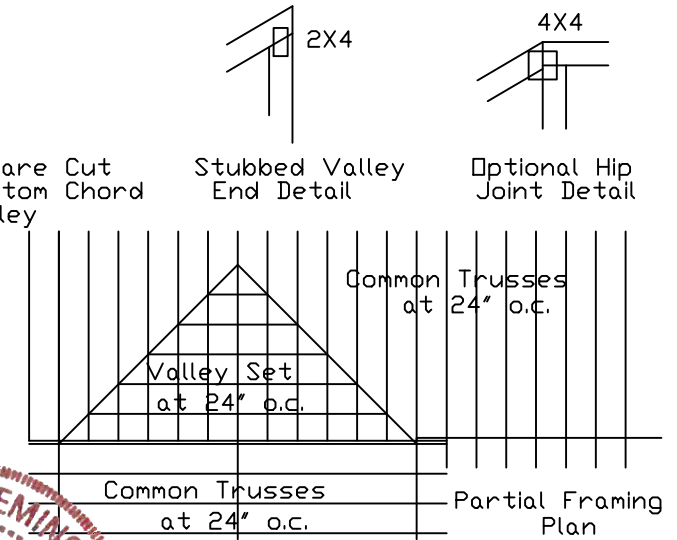
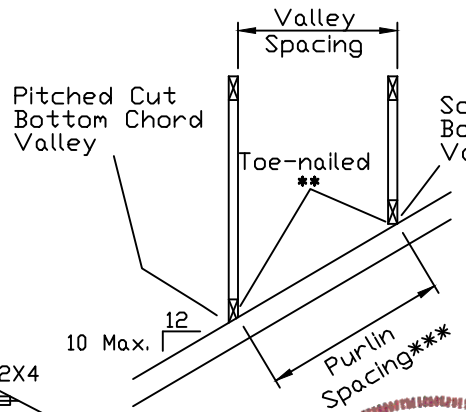
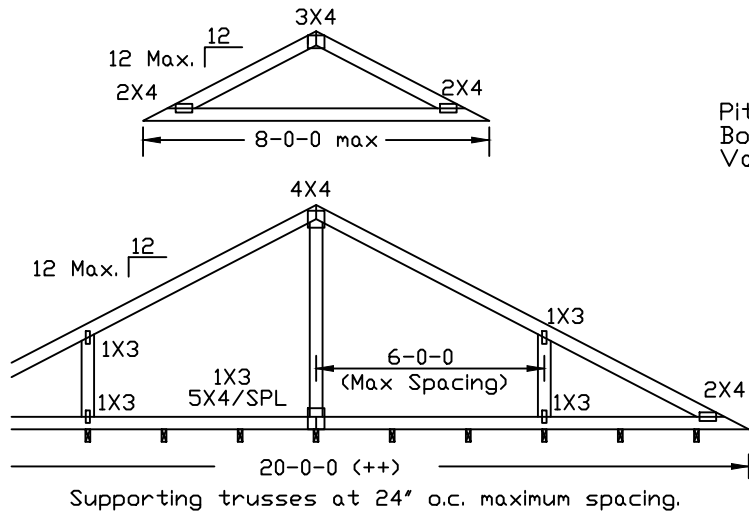

**WARNING READ AND FOLLOW ALL NOTES ON THIS DRAWING**  
**IMPORTANT FURNISH THIS DRAWING TO ALL CONTRACTORS INCLUDING THE INSTALLERS.**  
 Trusses require extreme care in fabricating, handling, shipping, installing and bracing. Refer to and follow the latest edition of BCSI (Building Component Safety Information, by TPI and SBCA) or safety practices prior to performing these functions. Installers shall provide temporary bracing per BCSI. Unless noted otherwise, top chord shall have properly attached structural sheathing and bottom chord shall have a properly attached rigid ceiling. Locations shown for permanent lateral restraint of webs shall have bracing installed per BCSI sections B3, B7 or B10, as applicable. Apply plates to each face of truss and position as shown above and on the Joint Details, unless noted otherwise. Refer to drawings 160A-Z for standard plate positions.  
 Alpine, a division of ITW Building Components Group Inc. shall not be responsible for any deviation from this drawing, any failure to build the truss in conformance with ANSI/TPI 1, or for handling, shipping, installation & bracing of trusses.  
 A seal on this drawing or cover page listing this drawing, indicates acceptance of professional engineering responsibility solely for the design shown. The suitability and use of this drawing for any structure is the responsibility of the Building Designer per ANSI/TPI 1 Sec.2.  
 For more information see this job's general notes page and these web sites:  
 ALPINE: www.alpineitw.com; TPI: www.tpinst.org; SBCA: www.sbcacomponents.com; ICC: www.iccsafe.org

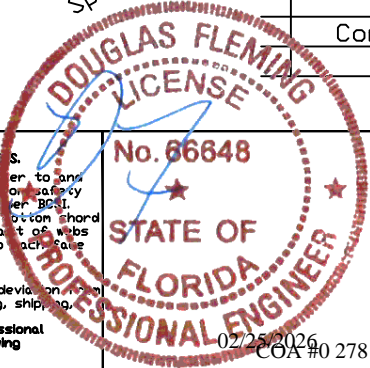

TC LL	30	30	40PSF	REF	VALLEY DETAIL
TC DL	20	15	7 PSF	DATE	07/03/2023
BC DL	10	10	10 PSF	DRWG	VALTN220723
BC LL	0	0	0 PSF		
TOT. LD.	60	55	57PSF		
DUR.FAC.1.25/1.33	1.15	1.15			
SPACING	24.0"				

Rev: 01/23/26

# Piggyback Detail - ASCE 7-22: 160 mph, 30' Mean Height, Enclosed, Exposure C, Kzt=1.00

160 mph Wind, 30.00 ft Mean Hgt, ASCE 7-22, Enclosed Bldg. located anywhere in roof, Exp C, Wind DL= 5.0 psf (min), Kzt=1.0.  
 Or 140 mph wind, 30.00 ft Mean Hgt, ASCE 7-22, Enclosed Bldg. located anywhere in roof, Exp D, wind DL= 5.0 psf (min), Kzt=1.0.

Note: Top chords of trusses supporting piggyback cap trusses must be adequately braced by sheathing or purlins. The building designer shall provide diagonal bracing or any other suitable anchorage to permanently restrain purlins, and lateral bracing for out of plane loads over gable ends.

Maximum truss spacing is 24' o.c. Detail is not applicable if cap supports additional loads such as cupola, steeple, chimney or drag strut loads.

\*\* Refer to Engineer's sealed truss design drawing for piggyback and base truss specifications.

## Detail A : Purlin Spacing = 24" o.c. or less

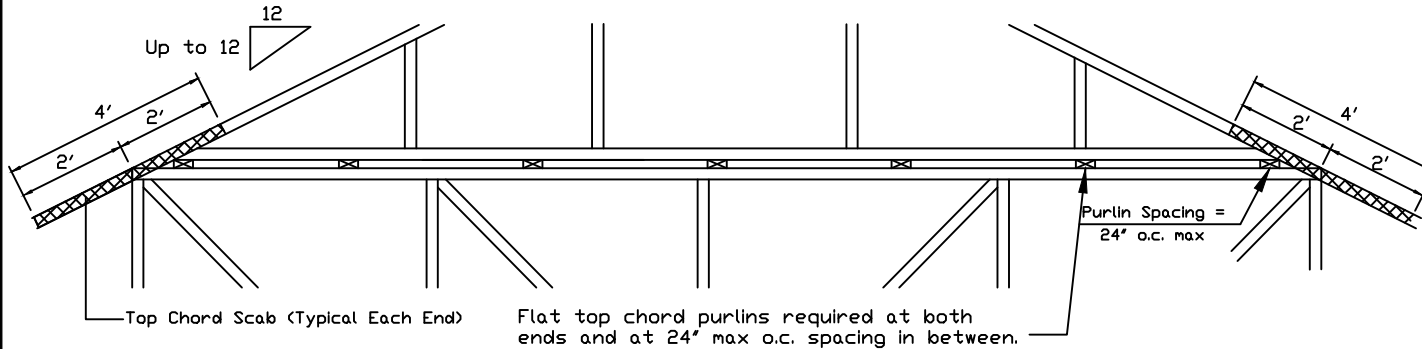

Piggyback cap truss slant nailed to all top chord purlin bracing with (2) 16d box nails (0.135"x3.5") and secure top chord with 2x4 #3 grade scab (1 side only at each end) attached with 2 rows of 10d box nails (0.128"x3") at 4' o.c.

Attach purlin bracing to the flat top chord using (2) 16d box nails (0.135"x3.5").

The top chord #3 grade 2x4 scab may be replaced with either of the following: (1) 3X8 Trulox plate attached with (8) 0.120"x1.375" nails, (4) into cap TC & (4) into base truss TC or (1) 28PB wave piggyback plate to the piggyback truss TC and attached to the base truss TC with (4) 0.120"x1.375" nails. Note: Nailing thru holes of wave plate is acceptable.

## Detail B : Purlin Spacing > 24" o.c.

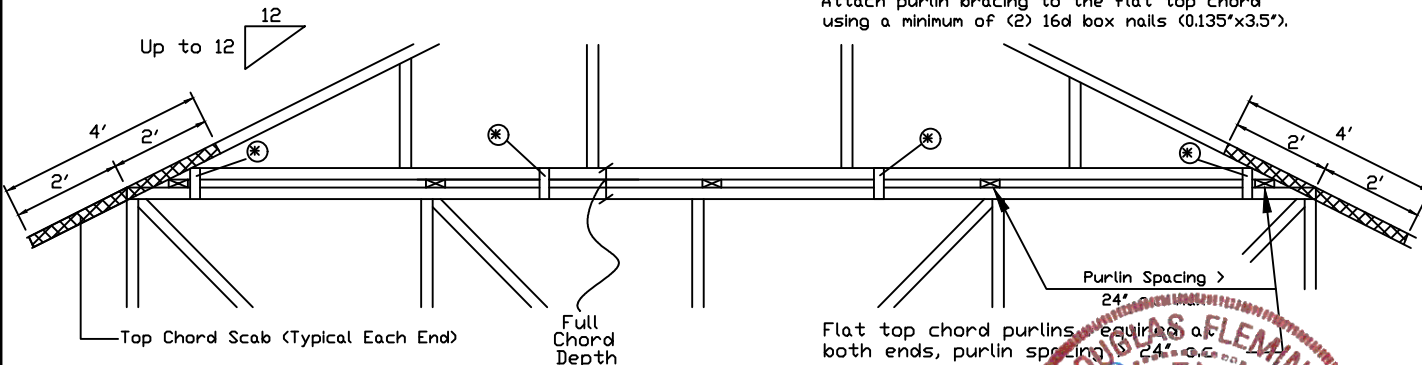

Piggyback cap truss slant nailed to all top chord purlin bracing with (2) 16d box nails (0.135"x3.5") and secure top chord with 2x4 #3 grade scab (1 side only at each end) attached with 2 rows of 10d box nails (0.128"x3") at 4' o.c.

Attach purlin bracing to the flat top chord using a minimum of (2) 16d box nails (0.135"x3.5").

Note: If purlins or sheathing are not specified on the flat top of the base truss, purlins must be installed at 24' o.c. max. and use Detail A.

\* In addition, provide connection with one of the following methods:

- Trulox**  
Use 3X8 Trulox plates for 2x4 chord member, and 3X10 Trulox plates for 2x6 and larger chord members. Attach to each face @ 8' o.c. with (4) 0.120"x1.375" nails into cap bottom chord and (4) in base truss top chord. Trulox plates may be staggered 4' o.c. front to back faces.
- APA Rated Gusset**  
8"x8"x7/16" (min) APA rated sheathing gussets (each face). Attach @ 8' o.c. with (8) 6d common (0.113"x2") nails per gusset, (4) in cap bottom chord and (4) in base truss top chord. Gussets may be staggered 4' o.c. front to back faces.
- 2x4 Vertical Scabs**  
2x4 SPF #2, full chord depth scabs (each face). Attach @ 8' o.c. with (6) 10d box nails (0.128"x3") per scab, (3) in cap bottom chord and (3) in base truss top chord. Scabs may be staggered 4' o.c. front to back faces.
- 28PB Wave Piggyback Plate**  
One 28PB wave piggyback plate to each face @ 8' o.c. Attach teeth to piggyback at time of fabrication. Attach to supporting truss with (4) 0.120"x1.375" nails per face per ply. Piggyback plates may be staggered 4' o.c. front to back faces.

155 Harlem Ave  
North Building, 4th Floor  
Glenview, IL 60025

**WARNING: READ AND FOLLOW ALL NOTES ON THIS DRAWING. IMPORTANT: FURNISH THIS DRAWING TO ALL CONTRACTORS INCLUDING THE INSTALLERS.**

Trusses require extreme care in fabricating, handling, shipping, installing and bracing. Refer to the latest edition of BCSI (Building Component Safety Information, by TPI and SBCA) for safety practices prior to performing these functions. Installers shall provide temporary bracing per BCSI. Unless noted otherwise, top chord shall have properly attached structural sheathing and bottom chord shall have a properly attached rigid ceiling. Locations shown for permanent lateral restraint or webs shall have bracing installed per BCSI sections B3, B7 or B10, as applicable. Apply plates to each face of truss and position as shown above and on the Joint Details, unless noted otherwise. Refer to drawings 160A-Z for standard plate positions.

Alpine, a division of ITW Building Components Group Inc. shall not be responsible for any deviation from this drawing, any failure to build the truss in conformance with ANSI/TPI 1, or for handling, shipping, installation & bracing of trusses.

A seal on this drawing or cover page listing this drawing, indicates acceptance of professional engineering responsibility solely for the design shown. The suitability and use of this drawing for any structure is the responsibility of the Building Designer per ANSI/TPI 1 Sec.2.

For more information see this Job's general notes page and these web sites:  
 ALPINE: [www.alpineitw.com](http://www.alpineitw.com); TPI: [www.tpinst.org](http://www.tpinst.org); SBCA: [www.sbcacomponents.com](http://www.sbcacomponents.com); ICC: [www.iccsafe.org](http://www.iccsafe.org)

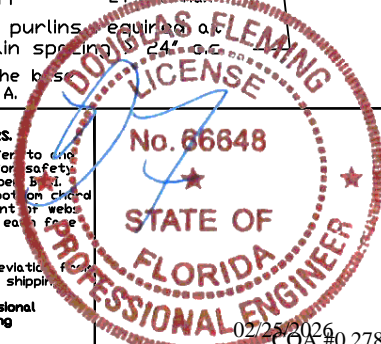

REF	PIGGYBACK
DATE	07/03/2023
DRWG	PB160220723
SPACING	24.0"

# STRONGBACK BRIDGING RECOMMENDATIONS

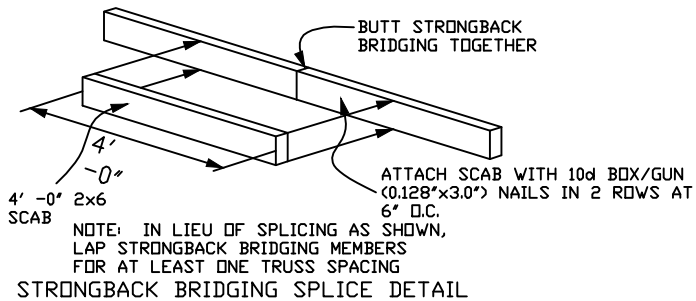

**STRONGBACK BRIDGING SPLICE DETAIL**

NOTE: Details 1 and 2 are the preferred attachment methods

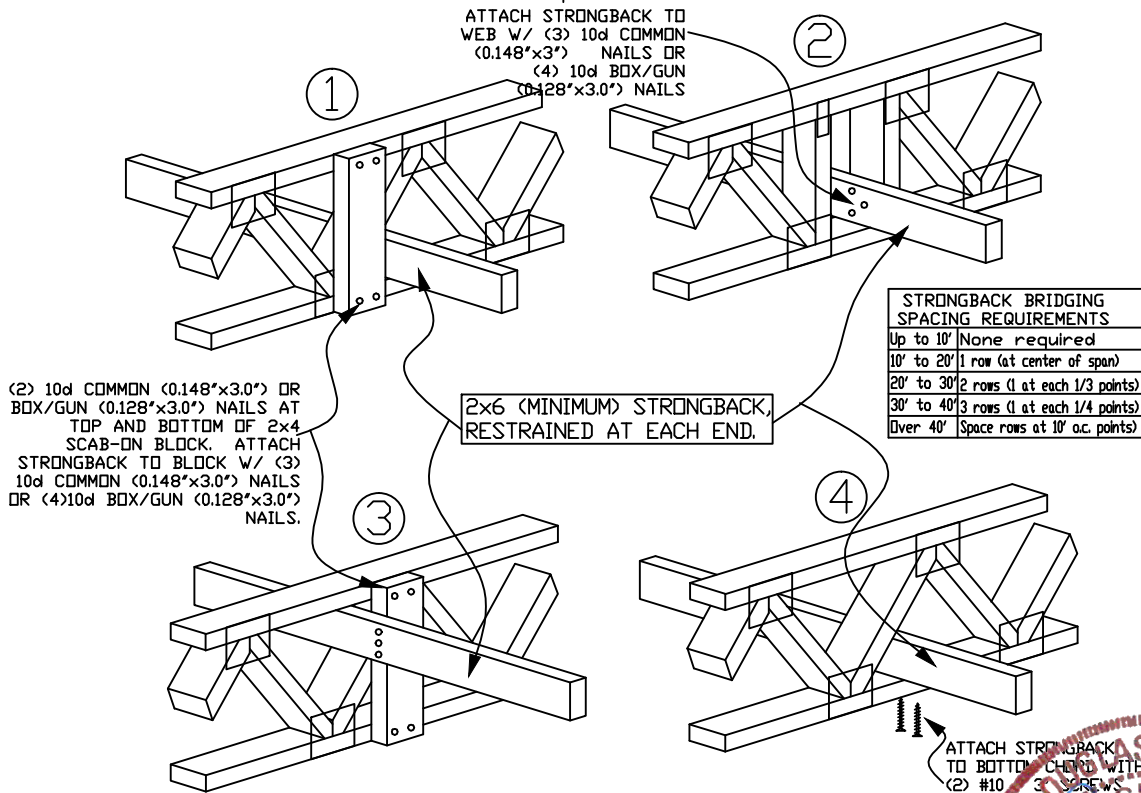

**STRONGBACK BRIDGING ATTACHMENT ALTERNATIVES**

- ▶ All scab-on blocks shall be a minimum 2x4 "stress graded lumber."
- ▶ All strongback bridging and bracing shall be a minimum 2x6 "stress graded lumber."
- ▶ The purpose of strongback bridging is to develop load sharing between individual trusses, resulting in an overall increase in the stiffness of the floor system. 2x6 strongback bridging, positioned as shown in details, is recommended at 10' -0" o.c. (max.)

▶ The terms "bridging" and "bracing" are sometimes mistakenly used interchangeably. "Bracing" is an important structural requirement of any floor or roof system. Refer to the Truss Design Drawing (TDD) for the bracing requirements for each individual truss component. "Bridging," particularly "strongback bridging" is a recommendation for a truss system to help control vibration. In addition to aiding in the distribution of point loads between adjacent truss, strongback bridging serves to reduce "bounce" or residual vibration resulting from moving point loads, such as footsteps.

The performance of all floor systems are enhanced by the installation of strongback bridging and therefore is strongly recommended by Alpine.

For additional information regarding strongback bridging, refer to BCSI (Building Component Safety Information).



155 Harlem Ave  
North Building, 4th Floor  
Glenview, IL 60025

**WARNING** READ AND FOLLOW ALL NOTES ON THIS DRAWING  
**IMPORTANT** FURNISH THIS DRAWING TO ALL CONTRACTORS INCLUDING THE INSTALLER

Trusses require extreme care in fabricating, handling, shipping, installing and bracing. Refer to and follow the latest edition of BCSI (Building Component Safety Information, by TPI and SBCA) for safety practices prior to performing these functions. Installers shall provide temporary bracing per BCSI. Unless noted otherwise, top chord shall have properly attached structural sheathing and bottom chord shall have a properly attached rigid ceiling. Locations shown for permanent lateral restraint of webs shall have bracing installed per BCSI sections B3, B7 or B10, as applicable. Apply plates to each face of truss and position as shown above and on the Joint Details, unless noted otherwise. Refer to drawings 160A-Z for standard plate positions.

Alpine, a division of ITW Building Components Group Inc. shall not be responsible for any deviation from this drawing, any failure to build the truss in conformance with ANSI/TPI 1, or for handling, shipping, installation & bracing of trusses.

A seal on this drawing or cover page listing this drawing, indicates acceptance of professional engineering responsibility solely for the design shown. The suitability and use of this drawing for any structure is the responsibility of the Building Designer per ANSI/TPI 1 Sec.2.

For more information see this Job's general notes page and these web sites:  
ALPINE: [www.alpineitw.com](http://www.alpineitw.com) TPI: [www.tpinet.org](http://www.tpinet.org) SBCA: [www.sbcacomponents.com](http://www.sbcacomponents.com) ICC: [www.iccsafe.org](http://www.iccsafe.org)

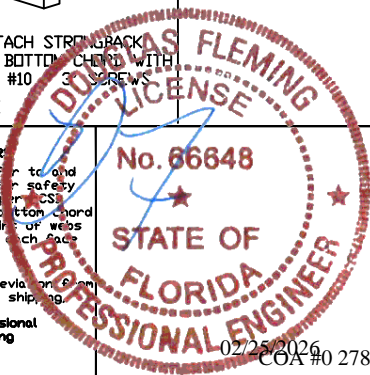

TC LL	PSF	REF	STRONGBACK
TC DL	PSF	DATE	10/01/14
BC DL	PSF	DRWG	STRBRIBR1014
BC LL	PSF		
TOT. LD.	PSF		
DUR. FAC.	1.00		
SPACING			