

**FRONT ELEVATION**

SCALE: 1/4" = 1'-0"

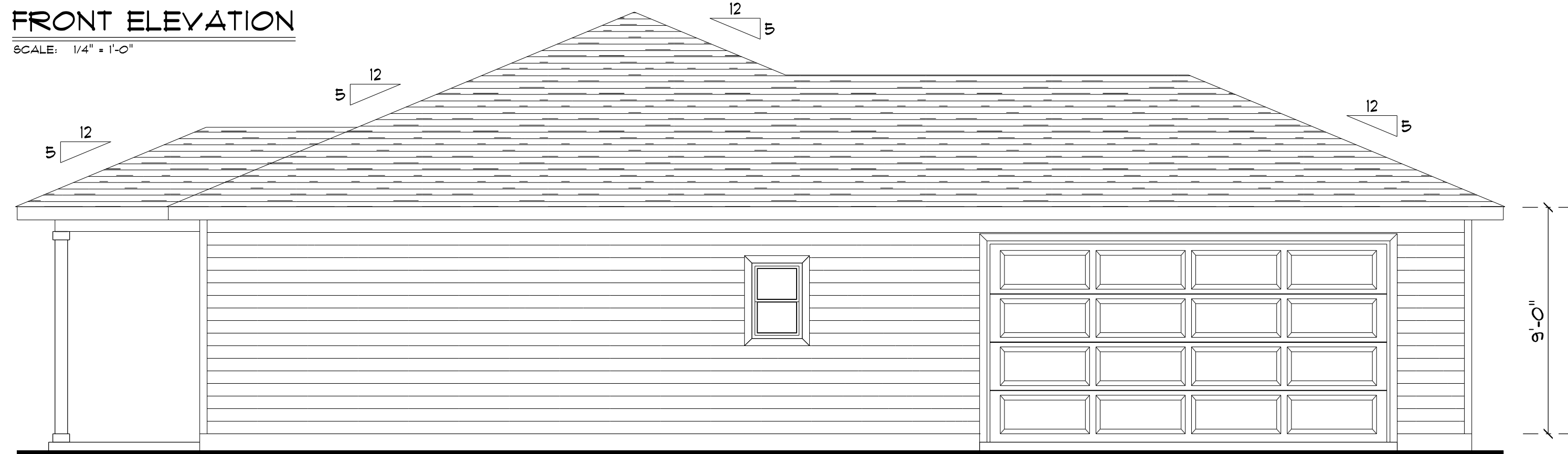

**LEFT ELEVATION**

SCALE: 1/4" = 1'-0"

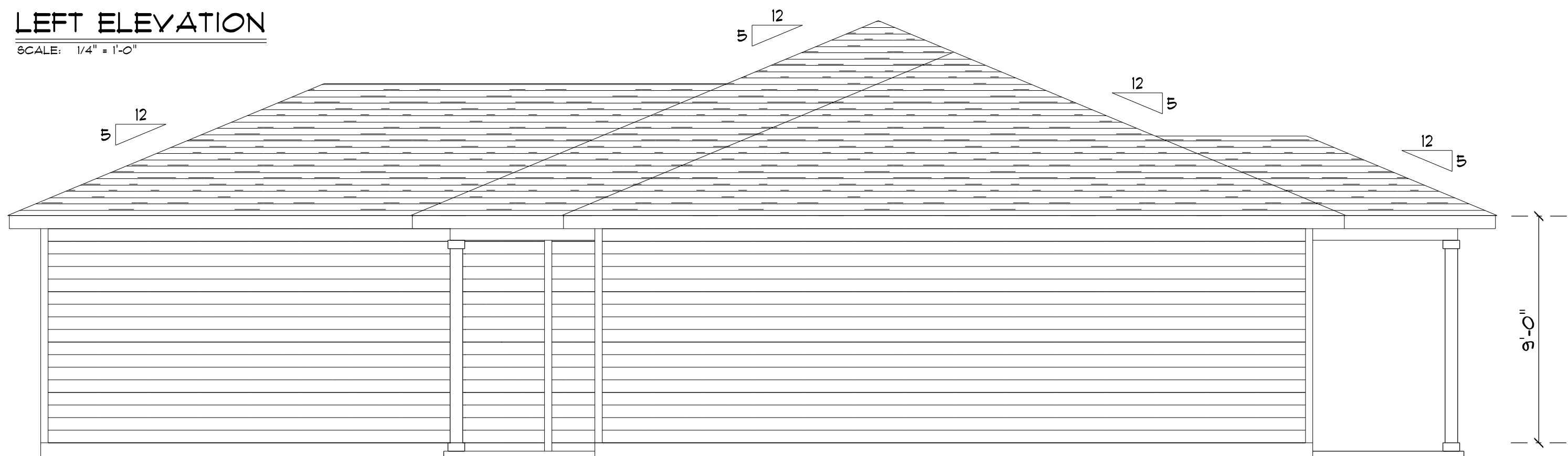

**RIGHT ELEVATION**

SCALE: 1/4" = 1'-0"

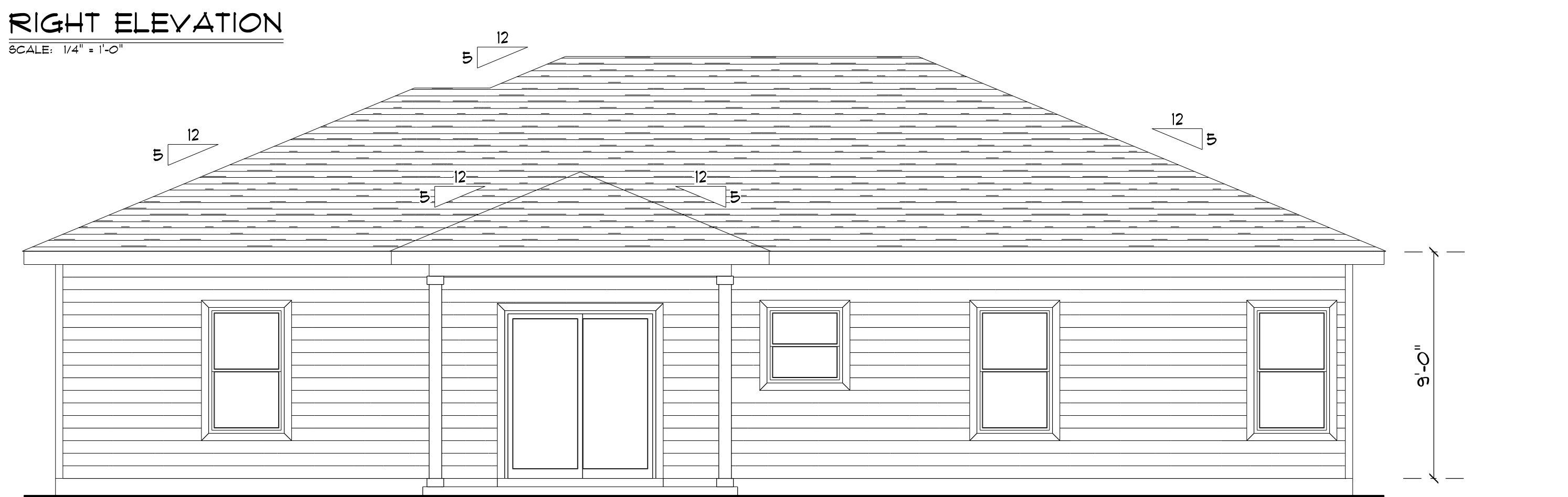

**REAR ELEVATION**

SCALE: 1/4" = 1'-0"

**ROOF VENTILATION:**  
 R806.2 Minimum vent area.  
 The minimum net free ventilating area shall be 1/150 of the area of the vented space.  
 Exception: The minimum net free ventilation area shall be 1/300 of the vented space provided one or more of the following conditions are met:  
 1. In Climate Zones 6, 7 and 8, a Class I or II vapor retarder is installed on the warm-in-winter side of the ceiling.  
 2. At least 40 percent and not more than 50 percent of the required ventilating area is provided by ventilators located in the upper portion of the attic or rafter space. Upper ventilators shall be located no more than 3 feet below the ridge or highest point of the space, measured vertically, with the balance of the required ventilation provided by eave or cornice vents. Where the location of wall or roof framing members conflicts with the installation of upper ventilators, installation more than 3 feet below the ridge or highest point of the space shall be permitted.

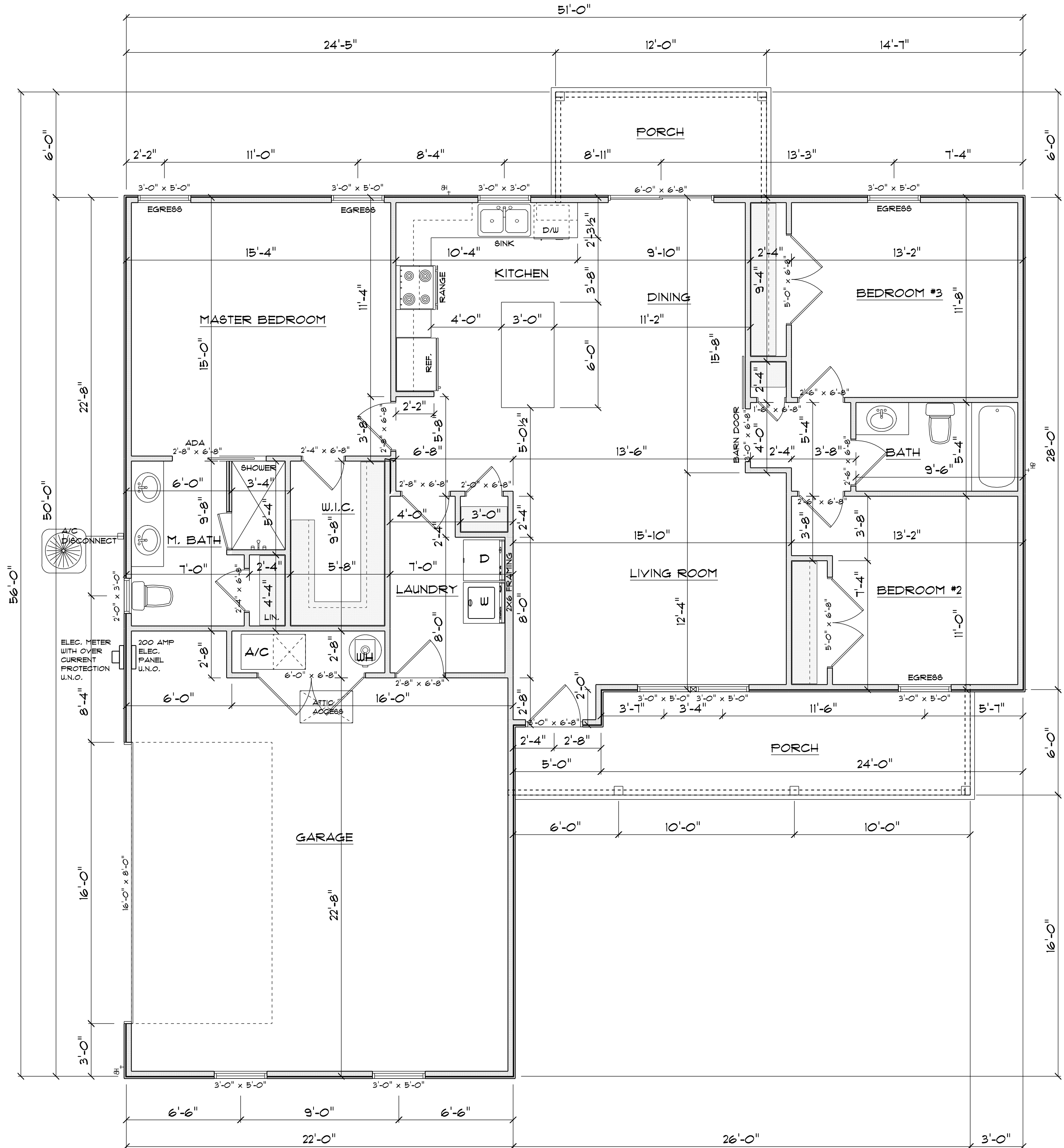

**FLOOR PLAN**

SCALE: 1/4" = 1'-0"

ALL CEILING HEIGHTS TO BE 9'-0" UNLESS NOTED OTHERWISE

**R302.5.1 Opening protection:**  
 Openings from a private garage directly into a room used for sleeping purposes shall not be permitted. Other openings between the garage and residence shall be equipped with solid wood doors not less than 1 3/8 inches in thickness, solid or honeycomb-core steel doors not less than 1 3/8 inches in thickness, solid or honeycomb-core steel doors not less than 1 3/8 inches thick, or 20-minute fire-rated doors, equipped with a self-closing device.

**TABLE R302.6 DWELLING/GARAGE SEPARATION:**

SEPARATION	MATERIAL
From the residence and attics	Not less than 1/2-inch gypsum board or equivalent applied to the garage side
From all habitable rooms above the garage	Not less than 5/8-inch Type X gypsum board or equivalent
Structure(s) supporting floor/ceiling assemblies used for separation required by this section	Not less than 1/2-inch gypsum board or equivalent
Garages located less than 3 feet from a dwelling unit on the same lot	Not less than 1/2-inch gypsum board or equivalent applied to the interior side of exterior walls that are within this area

**AREA SCHEDULE**

NAME	AREA
Living	1384 sq ft.
Front Porch	146 sq ft.
Rear Porch	72 sq ft.
Garage	538 sq ft.
Total	2140 sq ft.

DWC Contracting, LLC

Spec Home - Lot 97 Emerald Cove

PROJECT ADDRESS:  
 163 SW Midtown Place  
 Suite 103  
 Lake City, Florida 32025  
 386.754.5419  
 disoswaydesign@gmail.com

FL PE 53915  
 This item has been digitally signed and sealed by Mark Disosway PE on digital signature date. Printed copies of this document are not considered signed and sealed and the signature must be verified on any electronic copies.

**DIMENSIONS:**  
 Stated dimensions supersede scaled dimensions. Refer all questions to Mark Disosway, P.E. for resolution. Do not proceed without clarification.

**COPYRIGHTS AND PROPERTY RIGHTS:**  
 Mark Disosway, P.E. hereby expressly reserves its common law copyrights and property right in these instruments of service. This document is not to be reproduced, altered or copied in any form or manner without first the express written permission and consent of Mark Disosway.

**CERTIFICATION:** I hereby certify that I have examined this plan, and that the applicable portions of the plan, relating to wind engineering comply with the 8th Edition Florida Building Code Residential (2023) to the best of my knowledge.

**LIMITATION:** This design is valid for one building, at specified location.

**Mark Disosway P.E.**  
 163 SW Midtown Place  
 Suite 103  
 Lake City, Florida 32025  
 386.754.5419  
 disoswaydesign@gmail.com

**JOB NUMBER:**  
 260011

**1**  
 OF 5 SHEETS

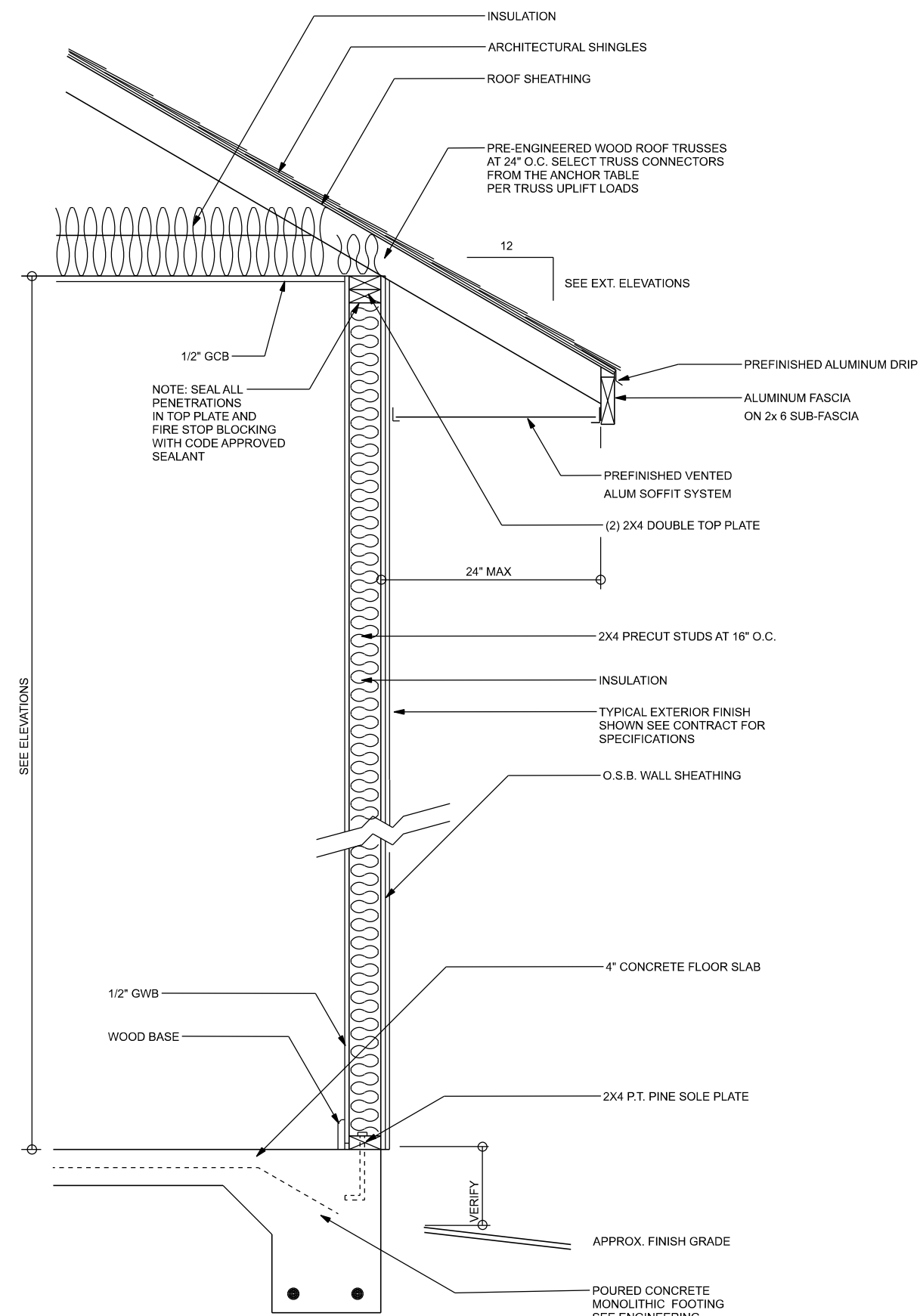

TYPICAL DESIGN WALL SECTION  
NON - STRUCTURAL DATA  
SCALE: N.T.S.

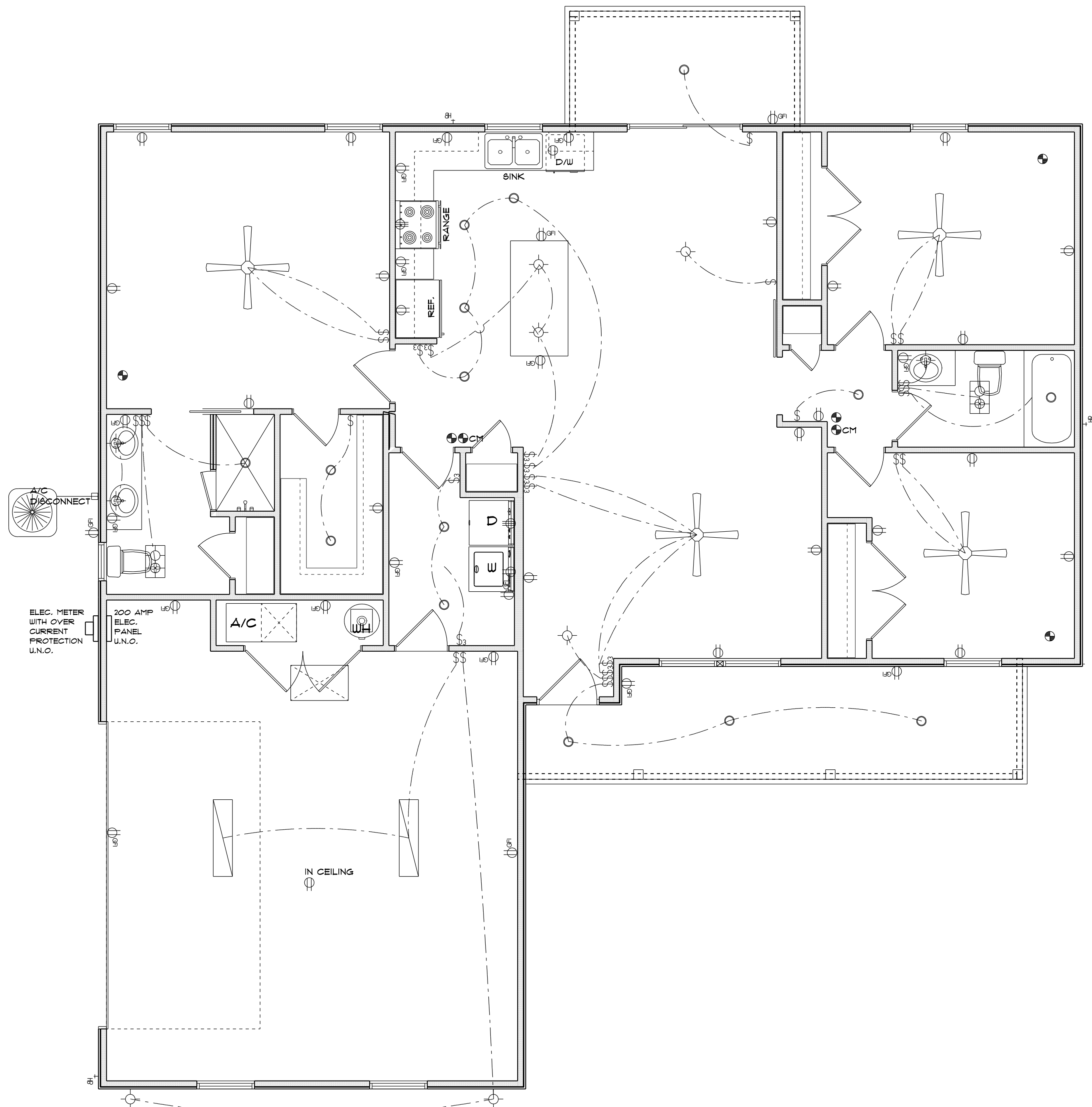

ELECTRICAL PLAN  
SCALE: 1/4" = 1'-0"

ELECTRICAL PLAN NOTES:	
E-1	WIRE ALL APPLIANCES, HVAC UNITS AND OTHER EQUIPMENT PER MANUF. SPECIFICATIONS.
E-2	CONSULT THE OWNER FOR THE NUMBER OF SEPARATE TELEPHONE LINES TO BE INSTALLED.
E-3	ALL INSTALLATIONS SHALL BE PER NATL. ELECTRIC CODE.
E-4	ALL SMOKE DETECTORS SHALL BE 120V W/ BATTERY BACKUP OF THE PHOTOELECTRIC TYPE AND SHALL BE INTERLOCKED TOGETHER. INSTALL INSIDE AND NEAR ALL BEDROOMS.
E-5	TELEPHONE, TELEVISION AND OTHER LOW VOLTAGE DEVICES OR OUTLETS SHALL BE AS PER THE OWNER'S DIRECTIONS, & IN ACCORDANCE W/ APPLICABLE SECTIONS OF NECA- LATEST EDITION.
E-6	ELECTRICAL CONTR'S SHALL BE RESPONSIBLE FOR THE DESIGN & SIZING OF ELECTRICAL SERVICE AND CIRCUITS.
E-7	ENTRY OF SERVICE ( UNDERGROUND OR OVERHEAD ) TO BE DETERMINED BY POWER COMPANY.
E-8	ALL 120-VOLT, SINGLE-PHASE, 15- AND 20-AMPERE BRANCH CIRCUITS SUPPLYING OUTLETS INSTALLED IN DWELLING UNIT FAMILY ROOMS, DINING ROOMS, LIVING ROOMS, PARLORS, LIBRARIES, DEN'S, BEDROOMS, SUN ROOMS, RECREATION ROOMS, CLOSETS, HALLWAYS, OR SIMILAR ROOMS OR AREAS SHALL BE PROTECTED BY A LISTED ARC-FAULT CIRCUIT INTERRUPTER, COMBINATION-TYPE INSTALLED TO PROVIDE PROTECTION OF THE BRANCH CIRCUIT.
E-9	ALL OUTLETS TO BE LOCATED ABOVE BASE FLOOD ELEVATION.
E-10	A SERVICE DISCONNECT WITH OVER CURRENT PROTECTION SHALL BE INSTALLED OUTSIDE OF THE BUILDING, ON THE LOAD SIDE OF THE METER, AT THE PLACE ELECTRIC CONDUCTORS ENTER THE BUILDING.
E-11	SERVICE ENTRANCE CONDUCTORS MAY NOT BE LOCATED INSIDE OF THE OF THE BUILDING WITHOUT SPECIAL APPROVAL OF THE BUILDING OFFICIAL.
E-12	CARBON MONOXIDE ALARMS SHALL BE REQUIRED WITHIN 10' OF ALL ROOMS FOR SLEEPING PURPOSES IN BUILDINGS HAVING A FOSSIL-FUEL-BURNING HEATER OR APPLIANCE, A FIREPLACE, OR ATTACHED GARAGE.
E-13	ALL OUTLETS LOCATED IN RESIDENTIAL TO BE TAMPER-RESISTANT PER NEC.
E-14	A MINIMUM OF 75% OF PERMANENTLY INSTALLED LAMPS OR LIGHTING FIXTURES SHALL BE HIGH EFFICACY FBC EC SEC. R404.1

ELECTRICAL LEGEND	
	CEILING FAN (PRE-WIRE FOR LIGHT KIT)
	DOUBLE SECURITY LIGHT
	2x4 FLUORESCENT LIGHT FIXTURE
	RECESSED CAN LIGHT
	BATH EXHAUST FAN WITH LIGHT
	BATH EXHAUST FAN
	LIGHT FIXTURE
	DUPLEX OUTLET
	220v OUTLET
	GFI DUPLEX OUTLET
	SMOKE DETECTOR
	WALL SWITCH
	3 WAY WALL SWITCH
	4 WAY WALL SWITCH
	WATER PROOF GFI OUTLET
	PHONE JACK
	TELEVISION JACK
	GARAGE DOOR OPENER
	CARBON MONOXIDE ALARM

DWC Contracting, LLC  
Spec Home - Lot 97 Emerald Cove  
PROJECT ADDRESS:  
Lot 97 Emerald Cove  
Columbia County, FL

FL PE 53915  
This item has been digitally signed and sealed by Mark Disosway PE on digital signature date. Printed copies of this document are not considered signed and sealed and the signature must be verified on any electronic copies.

DIMENSIONS:  
Stated dimensions supersede scaled dimensions. Refer all questions to Mark Disosway, P.E. for resolution. Do not proceed without clarification.

COPYRIGHTS AND PROPERTY RIGHTS:  
Mark Disosway, P.E. hereby expressly reserves its common law copyrights and property right in these instruments of service. This document is not to be reproduced, altered or copied in any form or manner without first the express written permission and consent of Mark Disosway.

CERTIFICATION: I hereby certify that I have examined this plan, and that the applicable portions of the plan, relating to wind engineering comply with the 8th Edition Florida Building Code Residential (2023) to the best of my knowledge.

LIMITATION: This design is valid for one building, at specified location.

Mark Disosway P.E.  
163 SW Midtown Place  
Suite 103  
Lake City, Florida 32025  
386.754.5419  
disoswaydesign@gmail.com

JOB NUMBER:  
260011  
2  
OF 5 SHEETS

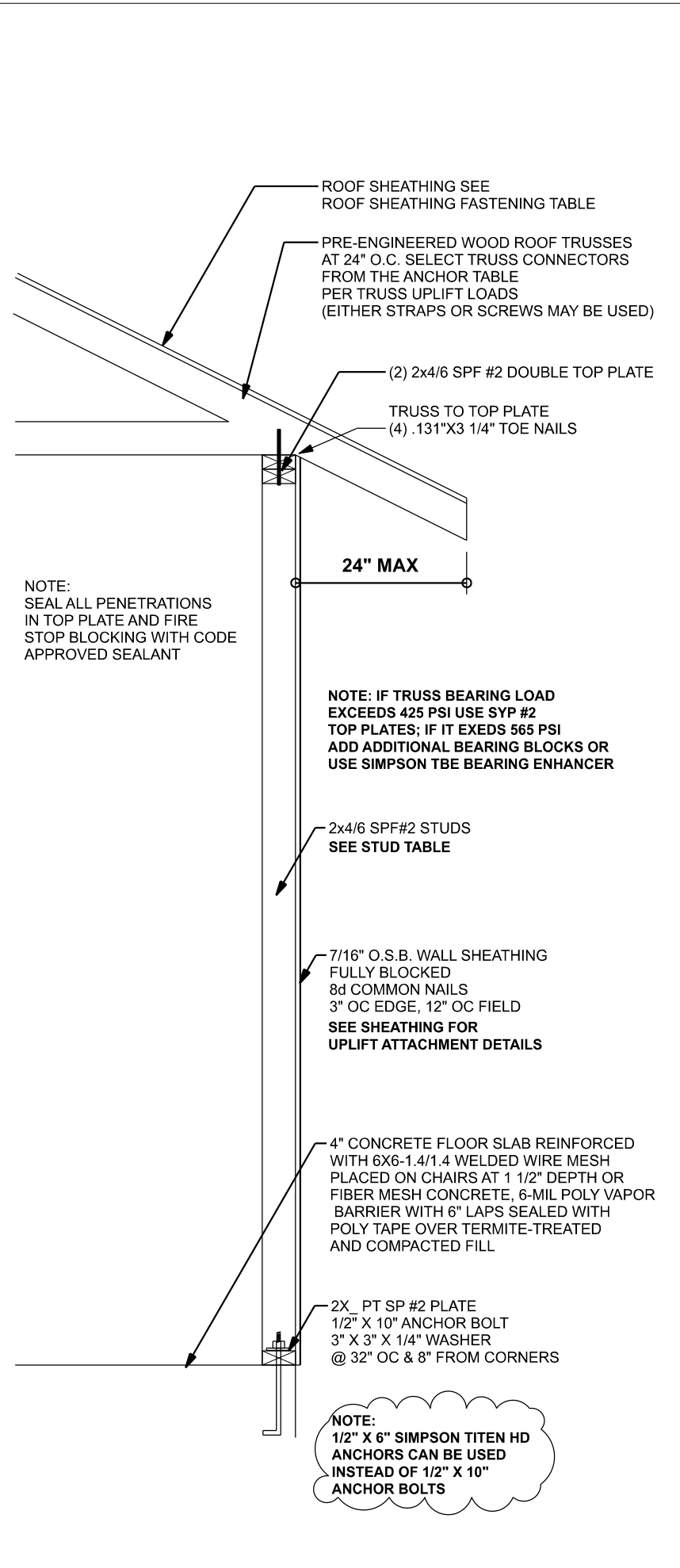

**ROOF SHEATHING FASTENING TABLE (RAFTER / TRUSS SG = 0.49)**

Wind Speed	Sheathing Thickness Or Plywood	Required Nail	Nail spacing along panel edges	Nail spacing along intermediate supports in the panel field
120 mph Exp. B	7/16"	ASTM F1667 RRS-01 (2.38" x 0.113")	6" OC	12" OC
120 mph Exp. C	19/32"	ASTM F1667 RRS-03 (2.12" x 0.131") or ASTM F1667 RRS-04 (3" x 0.120")	6" OC	6" OC
130 mph Exp. B	7/16"	ASTM F1667 RRS-01 (2.38" x 0.113")	6" OC	6" OC
130 mph Exp. C	19/32"	ASTM F1667 RRS-03 (2.12" x 0.131") or ASTM F1667 RRS-04 (3" x 0.120")	6" OC	6" OC
140 mph Exp. B	7/16"	ASTM F1667 RRS-01 (2.38" x 0.113")	6" OC	6" OC
140 mph Exp. C	19/32"	ASTM F1667 RRS-03 (2.12" x 0.131") or ASTM F1667 RRS-04 (3" x 0.120")	6" OC	6" OC
140 mph Exp. D	19/32"	ASTM F1667 RRS-03 (2.12" x 0.131") or ASTM F1667 RRS-04 (3" x 0.120")	6" OC	6" OC
150 mph Exp. C	19/32"	ASTM F1667 RRS-03 (2.12" x 0.131") or ASTM F1667 RRS-04 (3" x 0.120")	6" OC	6" OC
150 mph Exp. D	19/32"	ASTM F1667 RRS-03 (2.12" x 0.131") or ASTM F1667 RRS-04 (3" x 0.120")	4" OC	4" OC

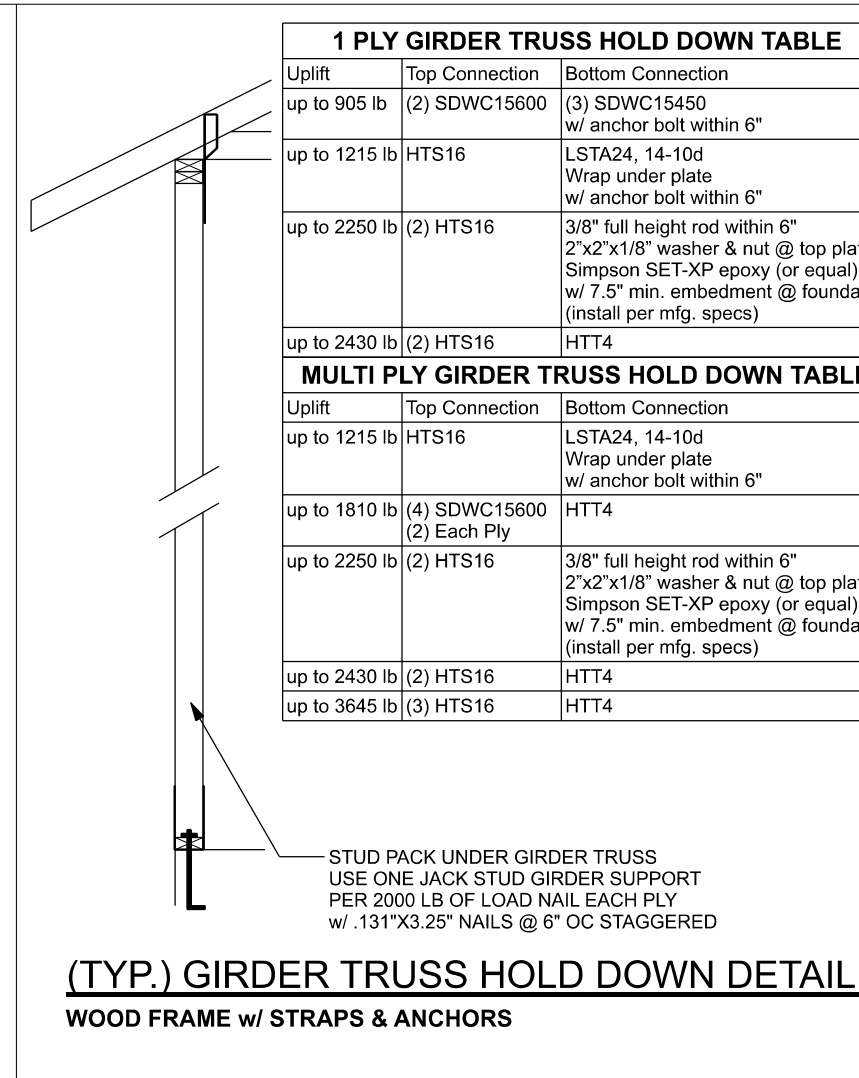
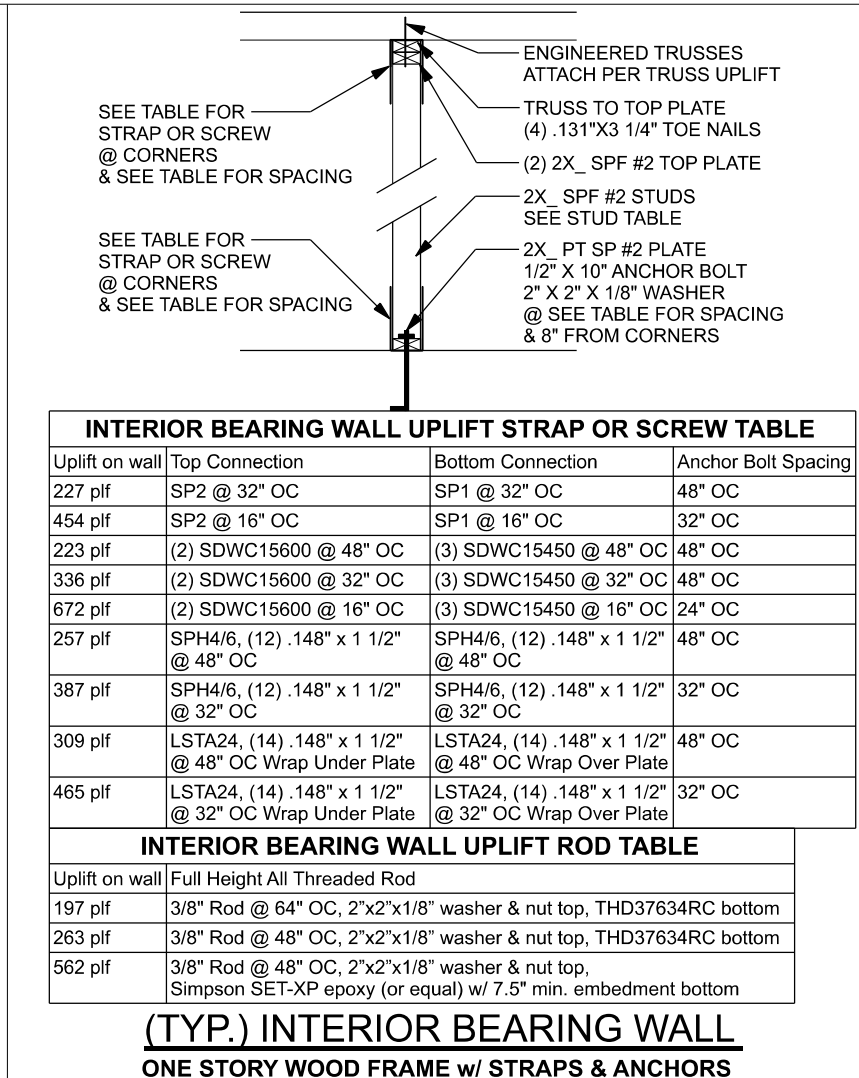
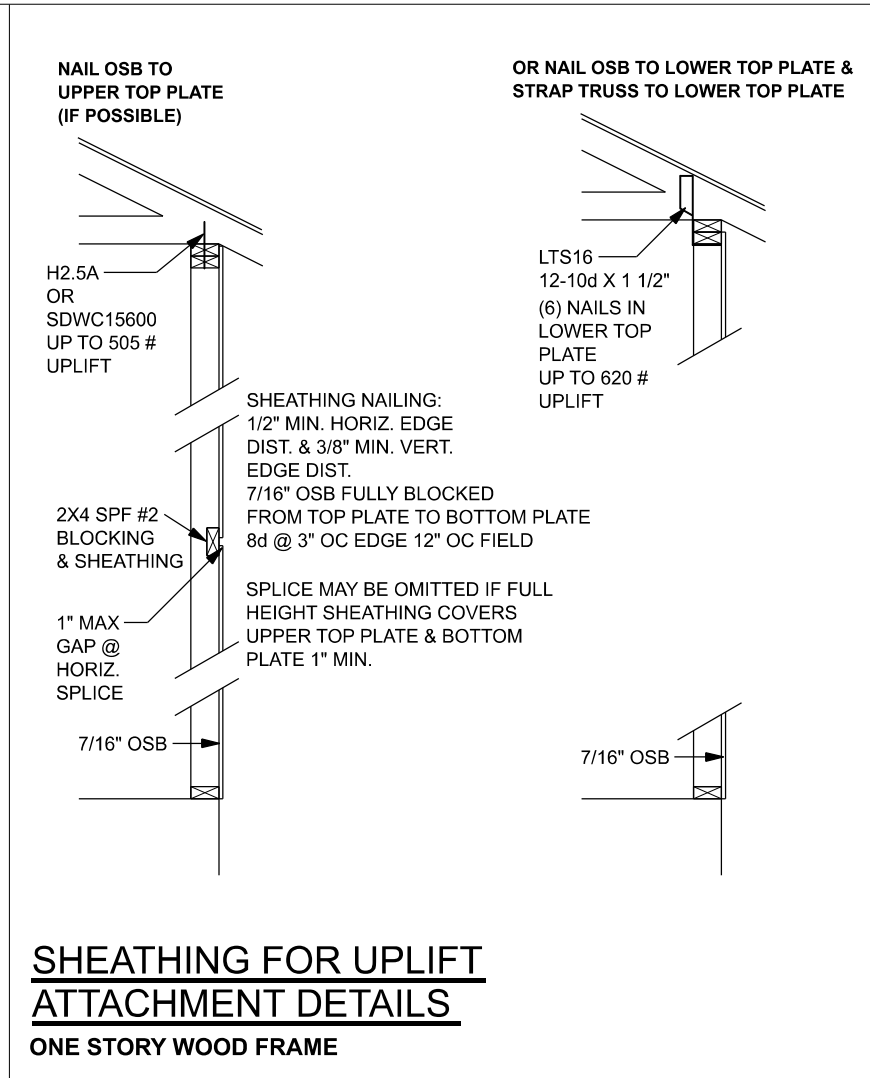

**CONNECTOR TABLE**

Uplift SP	Uplift SPP	Truss Connector	To Plate	To Truss/Rafter
805	505	SDWC15600	-	-
400	280	H3	4-131"x1 1/2"	4-131"x1 1/2"
625	540	H2.5A	5-131"x1 1/2"	5-131"x1 1/2"
1040	1015	H10A	9-148"x1 1/2"	9-148"x1 1/2"
645	515	LTS12-20	6-148"x1 1/2"	6-148"x1 1/2"
990	850	MST12-30	7-148"x1 1/2"	7-148"x1 1/2"
1415	1215	HTS16-30	8-148"x1 1/2"	8-148"x1 1/2"
Uplift SP	Uplift SPP	Strap Ties	To One Member	To Other Member
1235	1235	LSTA21	8-148"x1 1/2"	8-148"x1 1/2"
1940	1460	HSTA24	9-148"x1 1/2"	9-148"x1 1/2"
1030	1030	CS20	7-148"x1 1/2"	7-148"x1 1/2"
Uplift SP	Uplift SPP	Stud Plate Ties	To Stud	To Plate
555	535	SP1	4-148"x3"	4-148"x3"
1010	605	SP2	6-148"x3"	6-148"x3"
1260	1160	SP4#8	12-148"x1 1/2"	wrap under or over plate
771	771	LSTA24	10-148"x1 1/2"	wrap under or over plate
1235	1235	LSTA24	14-148"x1 1/2"	wrap under or over plate
Uplift SP	Uplift SPP	Holdowns @ Stewall	To Stud / Post	Anchor
2145	1835	DTT22	8-SDS 1/4"x1 1/2"	1/2"x12" Titen HD
4235	3640	HTT4	15-162"x2 1/2"	1/2"x12" Titen HD
Uplift SP	Uplift SPP	Holdowns @ Mono	To Stud / Post	Anchor
2145	1835	DTT22	8-SDS 1/4"x1 1/2"	1/2"x12" Titen HD
4235	3640	HTT4	15-162"x2 1/2"	1/2"x12" Titen HD
Uplift SP	Uplift SPP	Post Bases @ Stewall	To Post	Anchor
1900	ABU442	ABU442	12-162"x3 1/2"	5/8"x12" Drill & Epoxy
2475	ABU662	ABU662	12-162"x3 1/2"	5/8"x12" Drill & Epoxy
Uplift SP	Uplift SPP	Post Bases @ Mono	To Post	Anchor
1900	ABU442	ABU442	12-162"x3 1/2"	5/8"x7" Drill & Epoxy
2475	ABU662	ABU662	12-162"x3 1/2"	5/8"x7" Drill & Epoxy

**GENERAL NOTES:**

TRUSSES: TRUSSES SHALL BE DESIGNED BY A FLORIDA LICENSED ENGINEER IN ACCORDANCE WITH THE FBCR. TRUSS ENGINEERING SHALL INCLUDE TRUSS DESIGN, PLACEMENT PLANS, TEMPORARY AND PERMANENT BRACING DETAILS, TRUSS-TO-TRUSS CONNECTIONS, AND UPLIFT AND REACTION LOADS FOR ALL BEARING LOCATIONS. TRUSS ENGINEERING IS THE RESPONSIBILITY OF THE TRUSS MANUFACTURER AND SHALL BE DESIGNATED AND SEALED BY THE MANUFACTURER'S DESIGN ENGINEER. IT IS THE BUILDER'S RESPONSIBILITY TO VERIFY THE DESIGNER'S FULLY DETAILED TRUSS CONNECTIONS AND TO SELECT UPLIFT CONNECTIONS BASED ON TRUSS ENGINEERING UPLIFT AND PROVIDE FOOTINGS FOR INTERIOR BEARING WALLS. BUILDER IS TO FURNISH TRUSS ENGINEERING TO WIND LOAD ENGINEER FOR REVIEW OF TRUSS REACTION ON THE BUILDING STRUCTURE. STRAP 2X6 RAFTERS WITH MIN. UPLIFT CONNECTION 415LB EACH END; 2X8 RAFTERS 700 LB EACH END.

SITE PREPARATION: SITE ANALYSIS AND PREPARATION IS NOT PART OF THIS PLAN. FOUNDATION: CONFIRM THAT THE FOUNDATION DESIGN & SITE CONDITIONS MEET GRAVITY LOAD REQUIREMENTS (ASSUME 1500 PSF BEARING CAPACITY UNLESS VISUAL OBSERVATION OR SOILS TEST PROVES OTHERWISE).

CONCRETE: MINIMUM COMPRESSIVE STRENGTH OF CONCRETE AT 28 DAYS,  $F_c = 2500$  PSI. WELDED REINFORCED SLAB: 6" x 6" W14 x W14, FB = 85KSI. WELDED REINFORCED FABRIC (W/F) CONFORMING TO ASTM A185. LOCATED IN MIDDLE OF THE SLAB, SUPPORTED WITH APPROVED MATERIALS OR SUPPORTS AT SPACINGS NOT TO EXCEED 3'.

FIBER CONCRETE SLAB: CONCRETE SLABS ON GROUND CONTAINING SYNTHETIC FIBER REINFORCEMENT: FIBER LENGTH 1/2 INCH TO 2 INCHES. DOSAGE AMOUNTS FROM 0.75 TO 1.5 POUNDS PER CUBIC YARD PER THE MANUFACTURER'S RECOMMENDATIONS. FIBERS TO CONFORM WITH ASTM C 1116. SWIN CONTROL JOINTS IN ACCORDANCE WITH ASTM C 1116. CERTIFICATION OF COMPLIANCE WHEN REQUESTED BY BUILDING OFFICIAL.

CONTROL JOINTS: WHERE SPECIFIED, SAW CUT JOINTS IN SLAB-ON-GRADE SHALL BE CUT IN ACCORDANCE WITH ACI 302. JOINTS SHALL BE CUT WITHIN 12 HOURS OF SLAB PLACEMENT. THE LENGTH / WIDTH RATIO OF SLAB REINFORCING SHALL NOT EXCEED 1.5 AND TYPICAL SPACING OF CUTS TO BE 12". DO NOT CUT W/OUT INTERFERING WITH REINFORCING. (RECOMMENDED LOCATION OF CONTROL JOINTS IS SUBJECT TO OWNER AND CONTRACTOR APPROVAL. THE CONTROL JOINTS ARE NOT INTENDED TO PREVENT CRACKS BUT RATHER TO ENCOURAGE THE SLAB TO CRACK ON A GIVEN LINE.)

REBAR: ASTM A615, GRADE 40, DEFORMED BARS, F<sub>y</sub> = 40 KSI. ALL LAP SPACES 40" DB (25" FOR 5BARS). UNO. ALL REINFORCEMENT SHALL BE DETAILED AND PLACED IN ACCORDANCE WITH 315-96 U.I.G.

ROOF SHEATHING: ALL ROOFS ARE HORIZONTAL DIAPHRAGMS. SHEATHING UNLOCKED, APPLIED PERPENDICULAR TO FRAMING, OVER A MINIMUM OF 3 FRAMING MEMBERS, WITH PANEL EDGES STAGGERED.

STRUCTURAL CONNECTORS: MANUFACTURERS AND PRODUCT NUMBER FOR CONNECTORS, ANCHORS, AND REINFORCEMENT ARE LISTED FOR EXAMPLE NOT ENDORSEMENT. AN EQUIVALENT DEVICE OF THE SAME OR OTHER MANUFACTURER CAN BE SUBSTITUTED FOR ANY DEVICES LISTED IN THE EXAMPLE TABLES AS LONG AS IT MEETS THE REQUIRED LOAD CAPACITIES. MANUFACTURER'S INSTALLATION INSTRUCTIONS MUST BE FOLLOWED TO ACHIEVE RATED LOADS.

ANCHOR BOLTS: A-307 ANCHOR BOLTS WITH MINIMUM EMBEDMENT AS SPECIFIED IN DRAWINGS BUT NOT LESS THAN 7" IN CONCRETE OR REINFORCED BOND BEAM OR 15" IN GROUTED CMU.

**BUILDER'S RESPONSIBILITY:**  
THE BUILDER AND OWNER ARE RESPONSIBLE FOR THE FOLLOWING, WHICH ARE SPECIFICALLY NOT PART OF THE WIND LOAD ENGINEER'S SCOPE OF WORK. CONFIRM SITE CONDITIONS, FOUNDATION BEARING CAPACITY, GRADE AND BACKFILL HEIGHT, WIND SPEED AND DEBRIS ZONE, AND FLOOD ZONE. PROVIDE MATERIALS AND CONSTRUCTION TECHNIQUES, WHICH COMPLY WITH FBCR REQUIREMENTS FOR THE STATED WIND VELOCITY AND DESIGN PRESSURES. PROVIDE A CONTINUOUS LOAD PATH FROM TRUSSES TO FOUNDATION. IF YOU BELIEVE THE PLAN OMBITS A CONTINUOUS LOAD PATH CONNECTION, CALL THE WIND LOAD ENGINEER IMMEDIATELY. VERIFY THE TRUSS MANUFACTURER'S SEALED ENGINEERING INCLUDES TRUSS DESIGN, PLACEMENT PLANS, TEMPORARY AND PERMANENT BRACING DETAILS, TRUSS-TO-TRUSS CONNECTIONS, AND UPLIFT AND REACTION LOADS FOR ALL BEARING LOCATIONS.

**ROOF SYSTEM DESIGN:**  
THE SEAL ON THESE PLANS FOR COMPLIANCE WITH FBCR IS BASED ON REACTIONS, UPLIFTS, AND BEARING LOCATIONS IN TRUSS ENGINEERING SUBMITTED TO THE WIND LOAD ENGINEER. IT IS THE RESPONSIBILITY OF THE BUILDER TO CHECK ALL DETAILS OF THE COMPLETE ROOF SYSTEM DESIGN SUBMITTED BY THE TRUSS MANUFACTURER AND HAVE IT SIGNED AND SEALED BY A DESIGN PROFESSIONAL FOR CORRECT APPLICATION OF FIBER REQUIRED LOADS AND ANY SPECIAL LOADS. THE BUILDER IS RESPONSIBLE TO REVIEW EACH INDIVIDUAL TRUSS MEMBER AND THE TRUSS ROOF SYSTEM AS A WHOLE AND TO PROVIDE RESTRAINT FOR ANY LATERAL BRACING. THE BUILDER SHOULD USE CARE CHECKING THE ROOF DESIGN BECAUSE THE WIND LOAD ENGINEER IS SPECIFICALLY NOT RESPONSIBLE FOR THE TRUSS LAYOUT WHICH WAS CREATED BY THE TRUSS MANUFACTURER AND THE TRUSS DESIGNER ALSO GENES RESPONSIBILITY FOR THE LAYOUT PER NOTES ON THEIR SEALED TRUSS SHEETS.

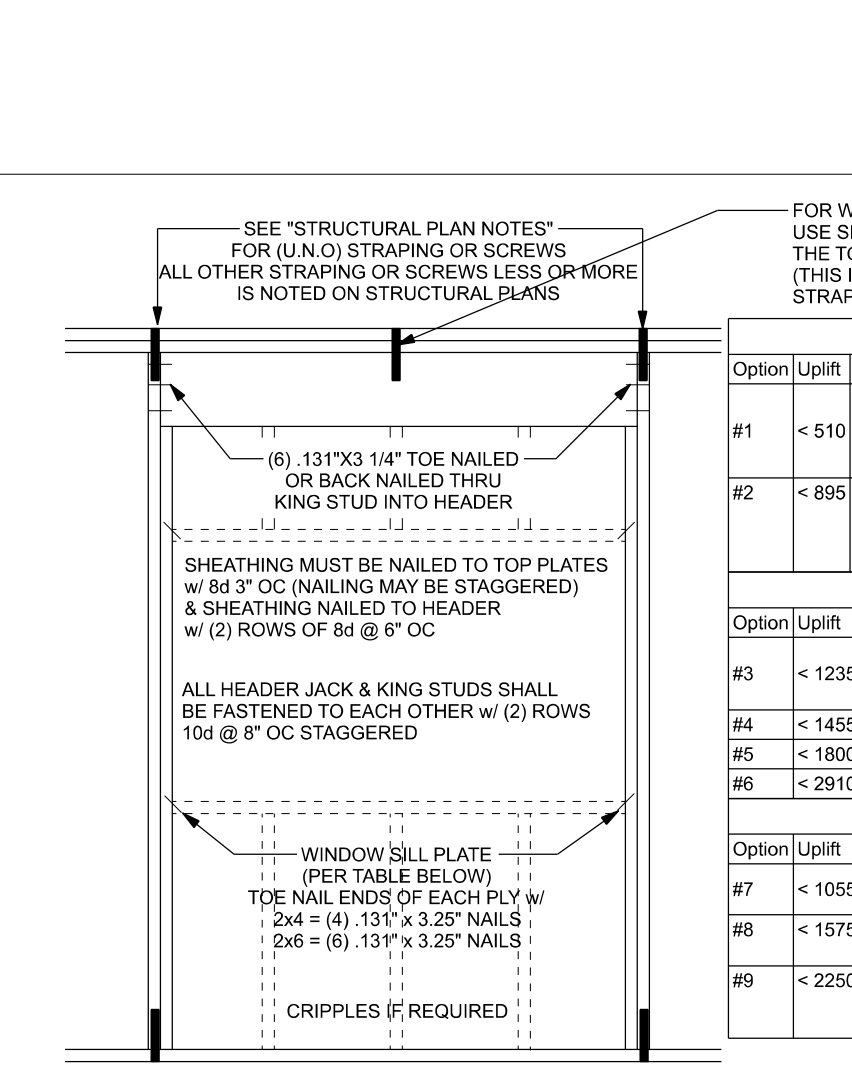
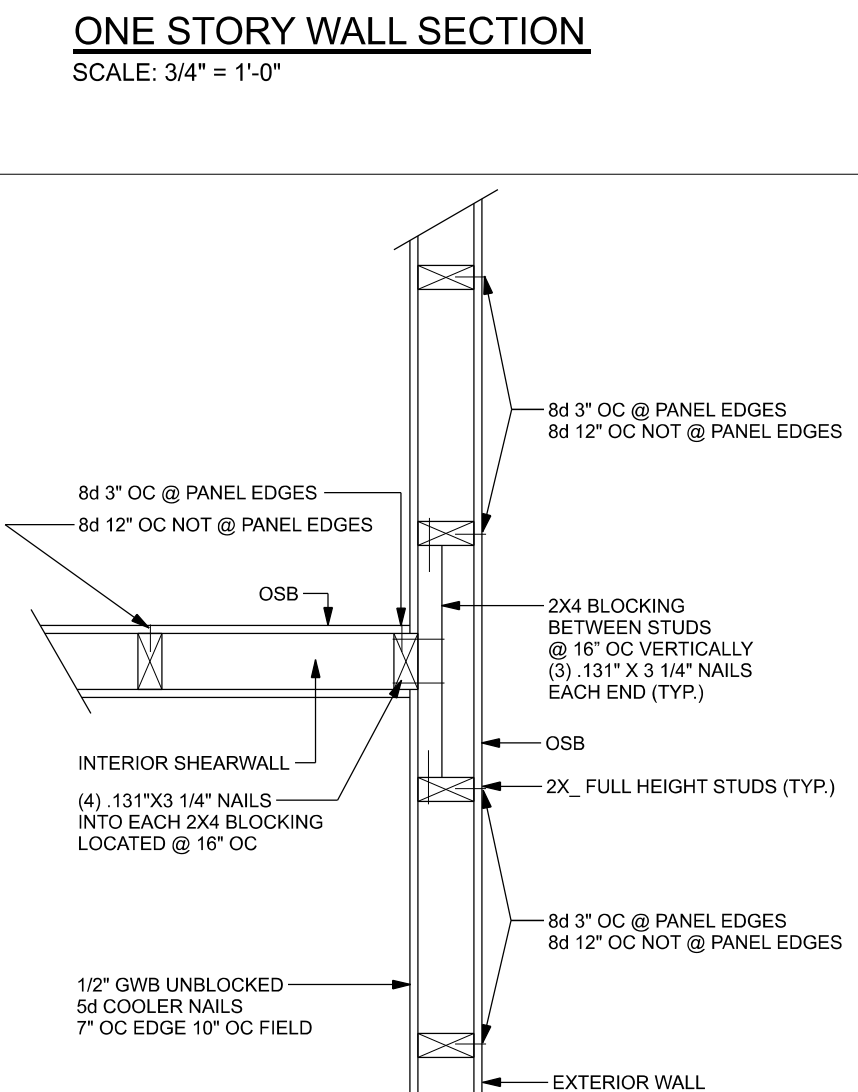

**HEADER STRAP TABLE**

Option	Uplift	Top Connection	Bottom Connection
#1	< 516	Attach king stud to top plate w/ (1) Simpson SDWC15600	Attach king stud to bottom plate w/ (2) Simpson SDWC15450 1/2" x 10" anchor bolt w/ 3" x 3" x 1/4" washer must be located within 6" of king stud @ all door locations
#2	< 895	Attach king stud to top plate w/ (2) Simpson SDWC15450	Attach king stud to bottom plate w/ (3) Simpson SDWC15450 1/2" x 10" anchor bolt w/ 3" x 3" x 1/4" washer must be located within 6" of king stud @ all door locations

**HEADER FULL HEIGHT ROD TABLE**

Option	Uplift	Top Connection	Bottom Connection
#3	< 1235	LSTA24, (14), 148" x 1 1/2" wrap over plate	LSTA24, (14), 148" x 1 1/2" wrap under plate
#4	< 1455	MSTA24, 18-, 148"x1 1/2" header to jacks	DTT22
#5	< 1800	(2) MSTA24, 18-, 148"x1 1/2" header to jacks	DTT22
#6	< 2910	(2) MSTA24, 18-, 148"x1 1/2" header to jacks	HTT4

**SILL PLATE SPANS FOR 10'-0" WALL HEIGHT**

DESIGN WIND SPEED	MAX. SPANS FOR SPP #2	BASED ON WFCM TABLE A3.2.3B
130 MPH EXP. C	5'-2"	7'-9"
	(1) 2x4	(1) 2x6
	(2) 2x4	(2) 2x6
	(3) FOR 2X4	(3) FOR 2X6
	(4) FOR 2X6	(4) FOR 2X6
	(5) FOR 2X8	(5) FOR 2X8
	(6) FOR 2X10	(6) FOR 2X10

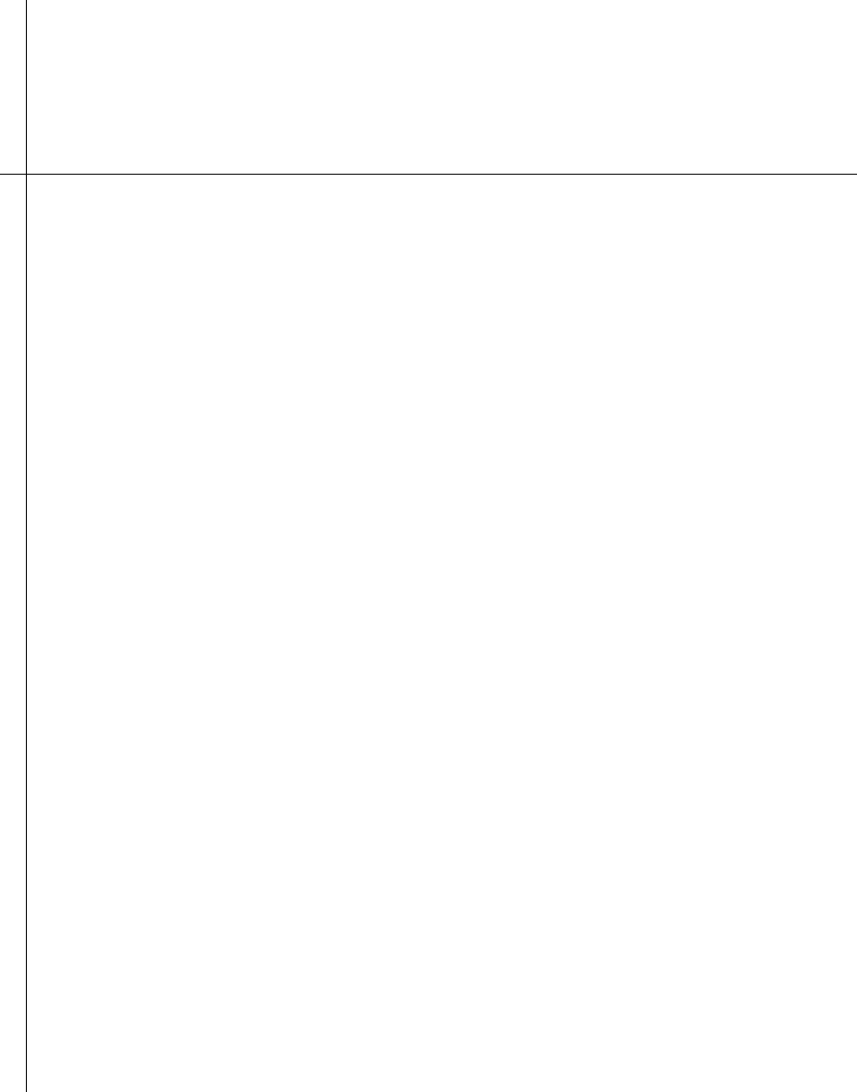
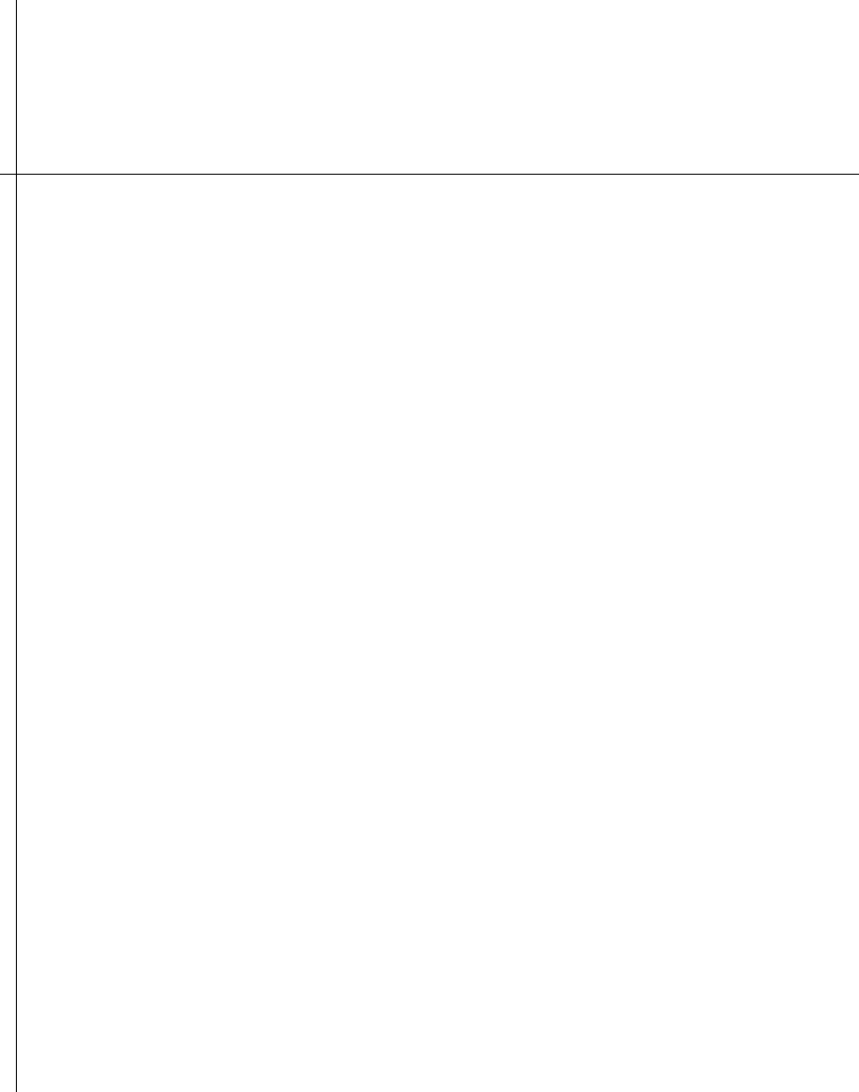
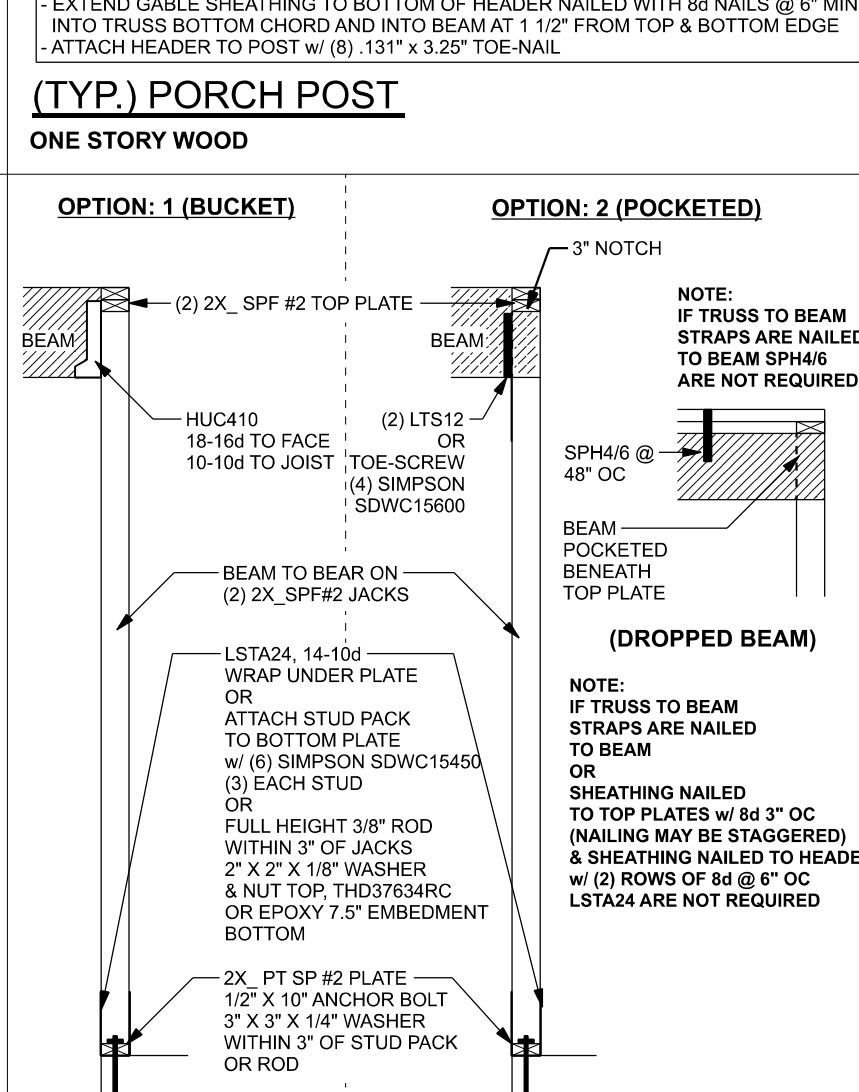

**DESIGN CRITERIA & LOADS:**

BUILDING CODE	8TH EDITION FLORIDA BUILDING CODE RESIDENTIAL (2023)
CODE FOR DESIGN LOADS	ASCE 7-22
WINDLOADS	BASIC WIND SPEED (ASCE 7-22, SS GUST) 130 MPH
WIND EXPOSURE	C
TOPOGRAPHIC FACTOR	1
RISK CATEGORY	II
ENCLOSURE CLASSIFICATION	ENCLOSED
INTERNAL PRESSURE COEFFICIENT	0.18
ROOF ANGLE	7-45 DEGREES
MEAN ROOF HEIGHT	30 FT
C&C DESIGN PRESSURES	SEE TABLE
FLOOR LOADING	40 PSF LIVE LOAD
SLEEPING ROOMS	30 PSF LIVE LOAD
ROOF LOADING	FLAT OR < 4:12 20 PSF LIVE LOAD
4:12 TO < 12:12	16 PSF LIVE LOAD
12:12 & GREATER	12 PSF LIVE LOAD
SOIL BEARING CAPACITY	1500 PSF
FLOOD ZONE	THIS BUILDING IS NOT IN THE FLOOD ZONE

**COMPONENT & CLADDING DESIGN PRESSURES 130 MPH (EXP. C)**

EFFECTIVE WIND AREA (F2)	ZONE 4 INTERIOR	ZONE 5 END 4 FROM ALL OUTSIDE CORNER
0 - 20	+25.6(Vasd) -27.8(Vasd)	+25.6(Vasd) -34.2(Vasd)
0 - 20	+42.6(Vult) -46.2(Vult)	+42.6(Vult) -57.1(Vult)

**GARAGE DOOR DESIGN PRESSURES 130 MPH (EXP. C)**

9x7 GARAGE DOOR	16x7 GARAGE DOOR
+22.6(Vasd) -25.5(Vasd)	+21.7(Vasd) -24.1(Vasd)

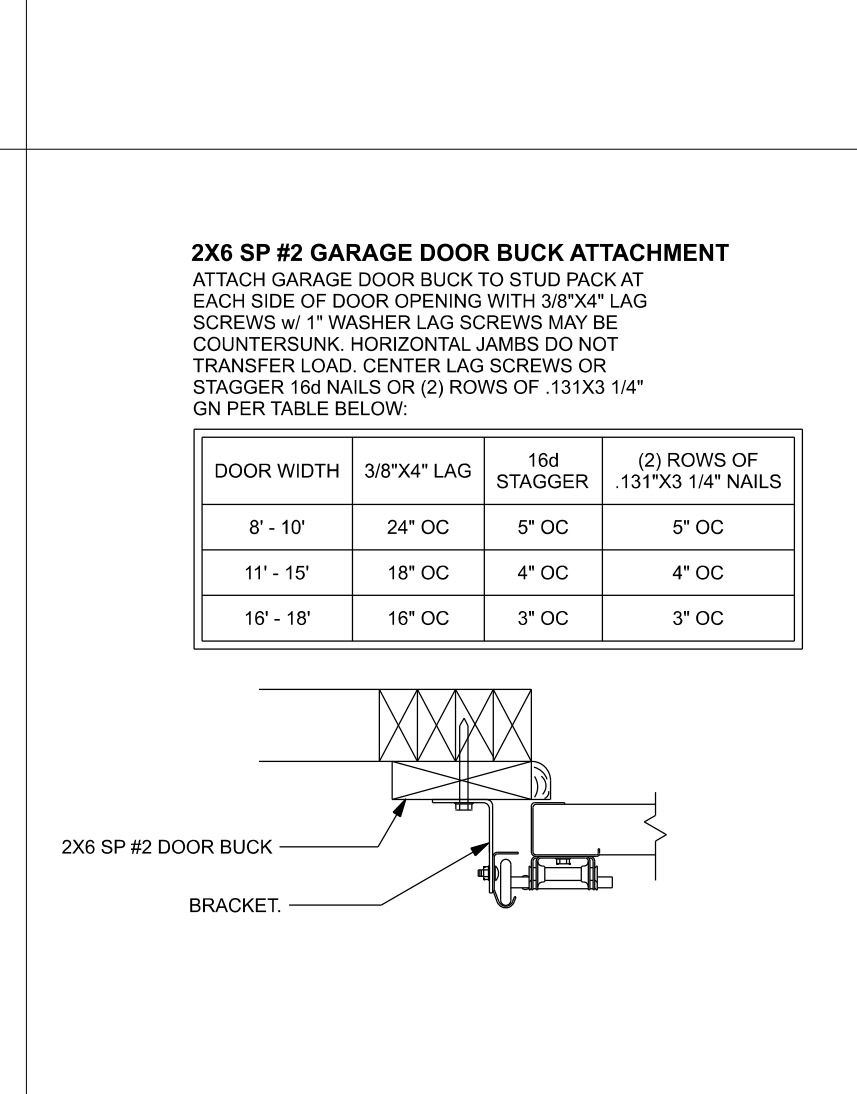
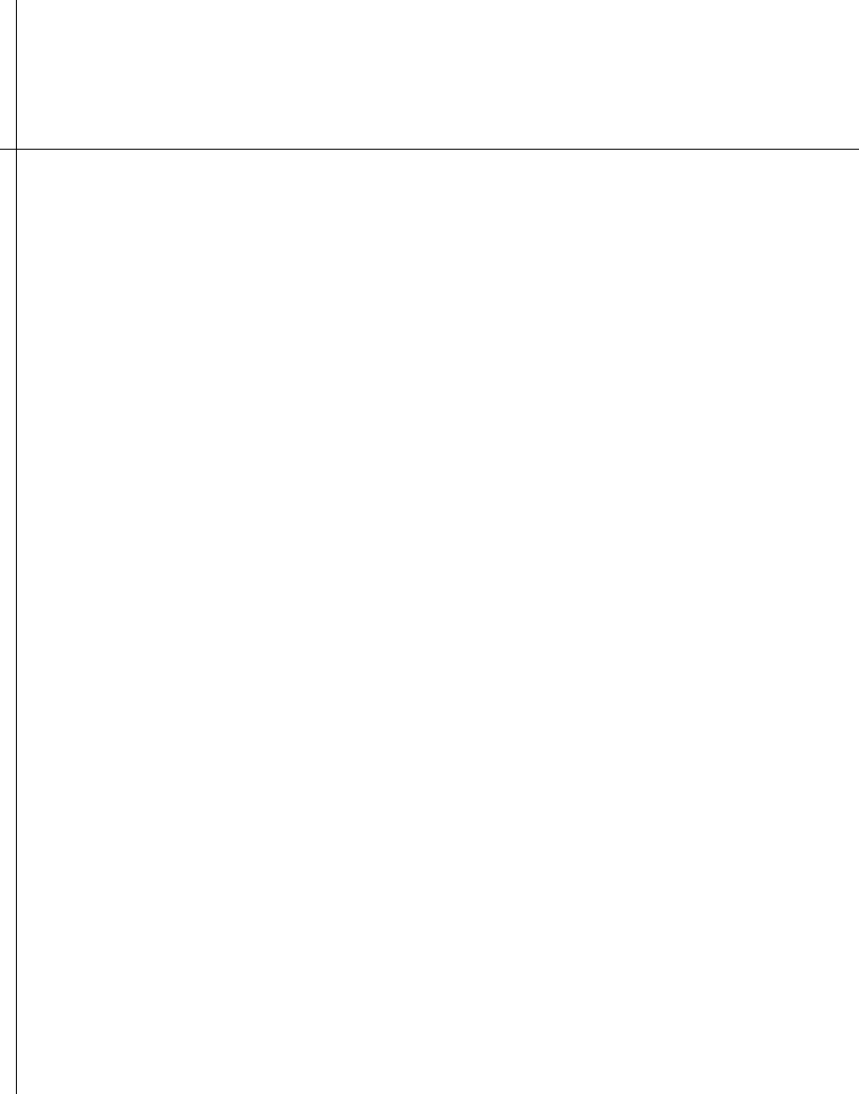
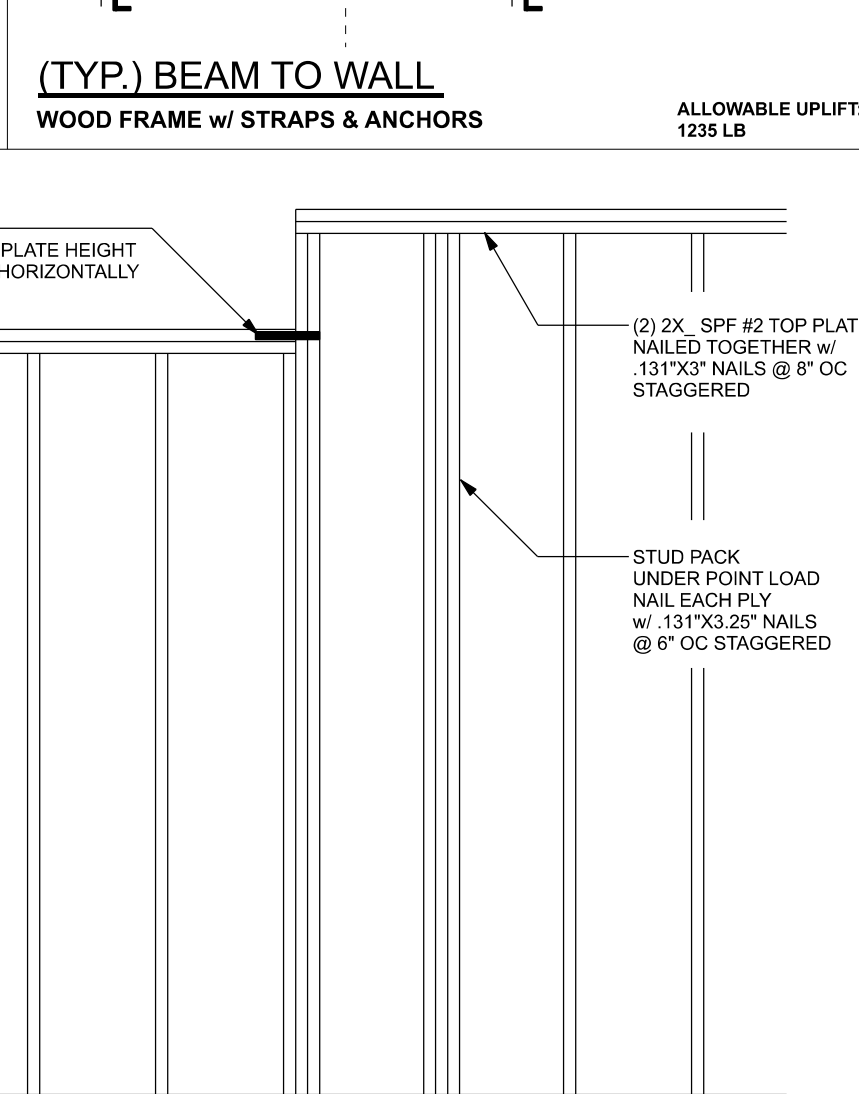
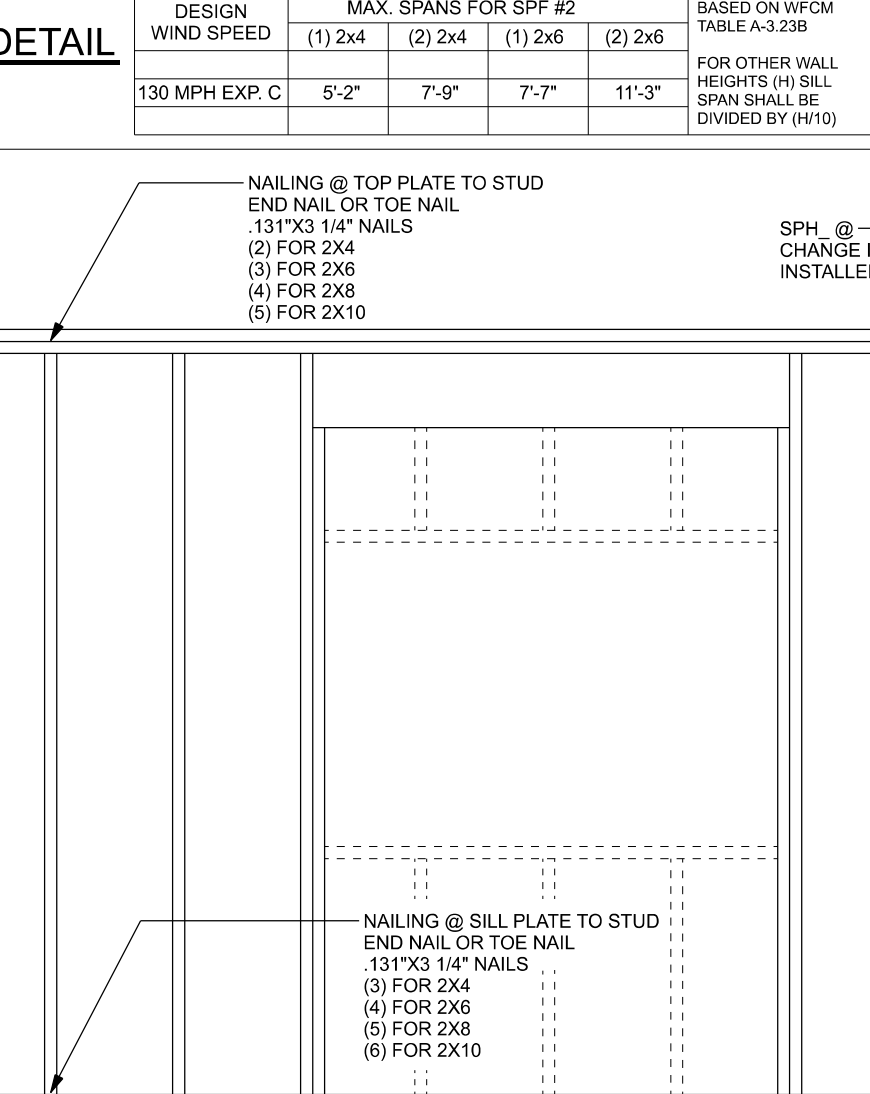
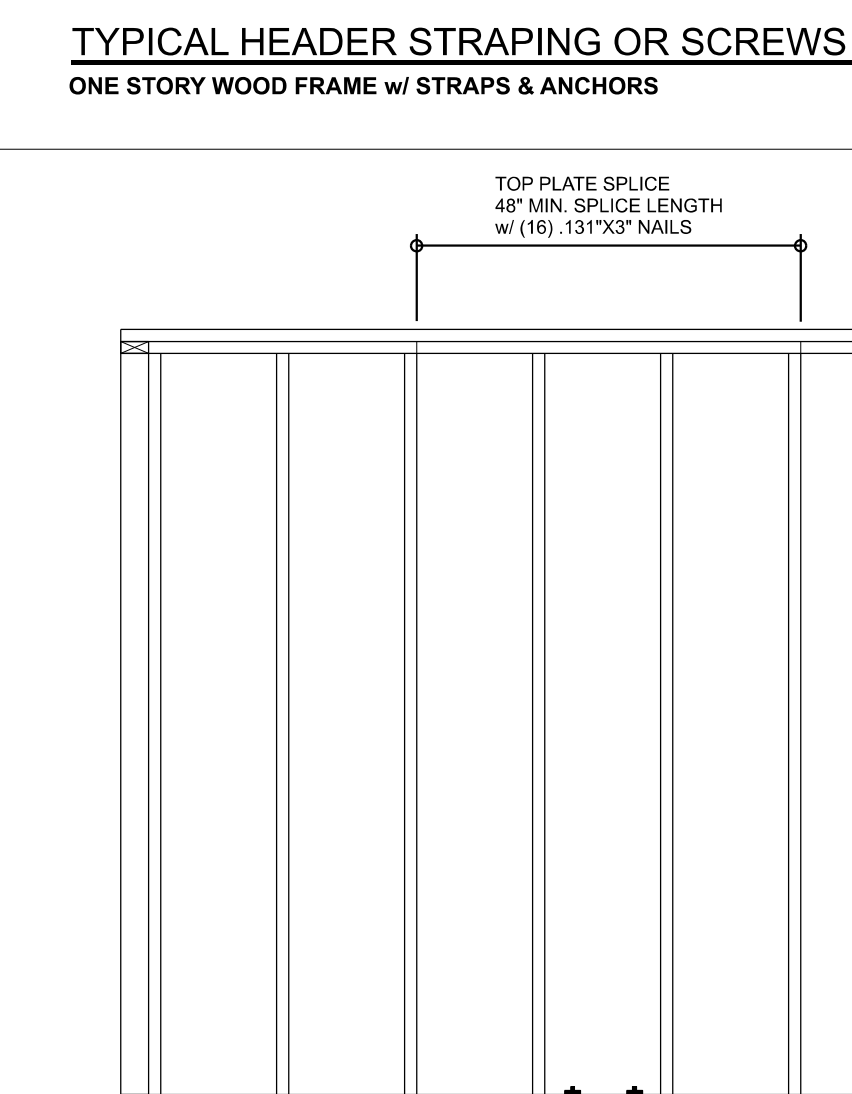
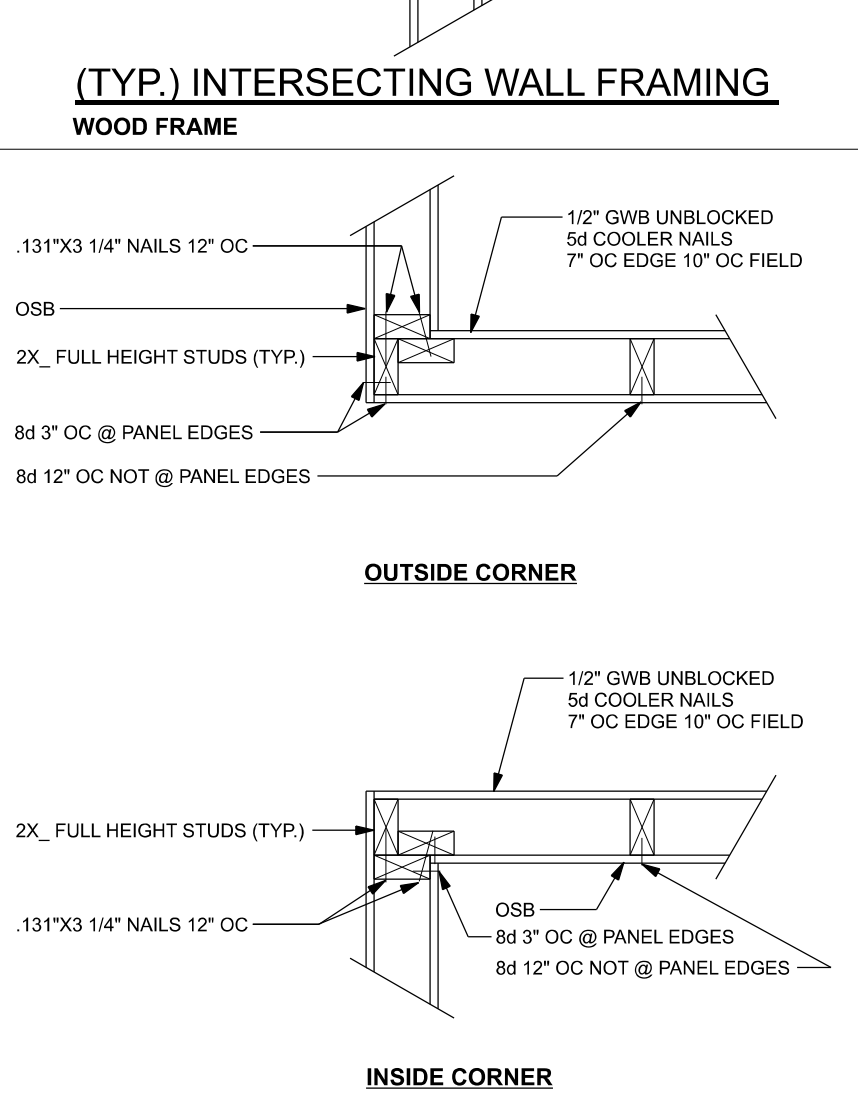

**DESIGN CRITERIA & LOADS:**

BUILDING CODE	8TH EDITION FLORIDA BUILDING CODE RESIDENTIAL (2023)
CODE FOR DESIGN LOADS	ASCE 7-22
WINDLOADS	BASIC WIND SPEED (ASCE 7-22, SS GUST) 130 MPH
WIND EXPOSURE	C
TOPOGRAPHIC FACTOR	1
RISK CATEGORY	II
ENCLOSURE CLASSIFICATION	ENCLOSED
INTERNAL PRESSURE COEFFICIENT	0.18
ROOF ANGLE	7-45 DEGREES
MEAN ROOF HEIGHT	30 FT
C&C DESIGN PRESSURES	SEE TABLE
FLOOR LOADING	40 PSF LIVE LOAD
SLEEPING ROOMS	30 PSF LIVE LOAD
ROOF LOADING	FLAT OR < 4:12 20 PSF LIVE LOAD
4:12 TO < 12:12	16 PSF LIVE LOAD
12:12 & GREATER	12 PSF LIVE LOAD
SOIL BEARING CAPACITY	1500 PSF
FLOOD ZONE	THIS BUILDING IS NOT IN THE FLOOD ZONE

**COMPONENT & CLADDING DESIGN PRESSURES 130 MPH (EXP. C)**

EFFECTIVE WIND AREA (F2)	ZONE 4 INTERIOR	ZONE 5 END 4 FROM ALL OUTSIDE CORNER
0 - 20	+25.6(Vasd) -27.8(Vasd)	+25.6(Vasd) -34.2(Vasd)
0 - 20	+42.6(Vult) -46.2(Vult)	+42.6(Vult) -57.1(Vult)

**GARAGE DOOR DESIGN PRESSURES 130 MPH (EXP. C)**

9x7 GARAGE DOOR	16x7 GARAGE DOOR
+22.6(Vasd) -25.5(Vasd)	+21.7(Vasd) -24.1(Vasd)

DWC Contracting, LLC

Spec Home - Lot 97 Emerald Cove

PROJECT ADDRESS:  
Lot 97 Emerald Cove  
Columbia County, FL

FL PE 53915

This item has been digitally signed and sealed by Mark Disosway, P.E. for resolution. Printed copies of this document are not considered signed and sealed and the signature must be verified on any electronic copies.

**DESIGN CRITERIA & LOADS:**

BUILDING CODE	8TH EDITION FLORIDA BUILDING CODE RESIDENTIAL (2023)
CODE FOR DESIGN LOADS	ASCE 7-22
WINDLOADS	BASIC WIND SPEED (ASCE 7-22, SS GUST) 130 MPH
WIND EXPOSURE	C
TOPOGRAPHIC FACTOR	1
RISK CATEGORY	II
ENCLOSURE CLASSIFICATION	ENCLOSED
INTERNAL PRESSURE COEFFICIENT	0.18
ROOF ANGLE	7-45 DEGREES
MEAN ROOF HEIGHT	30 FT
C&C DESIGN PRESSURES	SEE TABLE
FLOOR LOADING	40 PSF LIVE LOAD
SLEEPING ROOMS	30 PSF LIVE LOAD
ROOF LOADING	FLAT OR < 4:12 20 PSF LIVE LOAD
4:12 TO < 12:12	16 PSF LIVE LOAD
12:12 & GREATER	12 PSF LIVE LOAD
SOIL BEARING CAPACITY	1500 PSF
FLOOD ZONE	THIS BUILDING IS NOT IN THE FLOOD ZONE

**COMPONENT & CLADDING DESIGN PRESSURES 130 MPH (EXP. C)**

EFFECTIVE WIND AREA (F2)	ZONE 4 INTERIOR	ZONE 5 END 4 FROM ALL OUTSIDE CORNER
0 - 20	+25.6(Vasd) -27.8(Vasd)	+25.6(Vasd) -34.2(Vasd)
0 - 20	+42.6(Vult) -46.2(Vult)	+42.6(Vult) -57.1(Vult)

**GARAGE DOOR DESIGN PRESSURES 130 MPH (EXP. C)**

9x7 GARAGE DOOR	16x7 GARAGE DOOR
+22.6(Vasd) -25.5(Vasd)	+21.7(Vasd) -24.1(Vasd)

**JOB NUMBER:**  
260011

S-1

OF 5 SHEETS



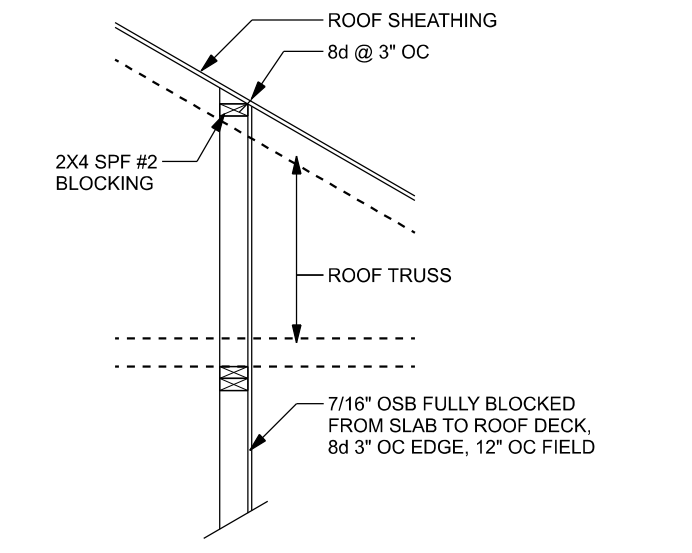
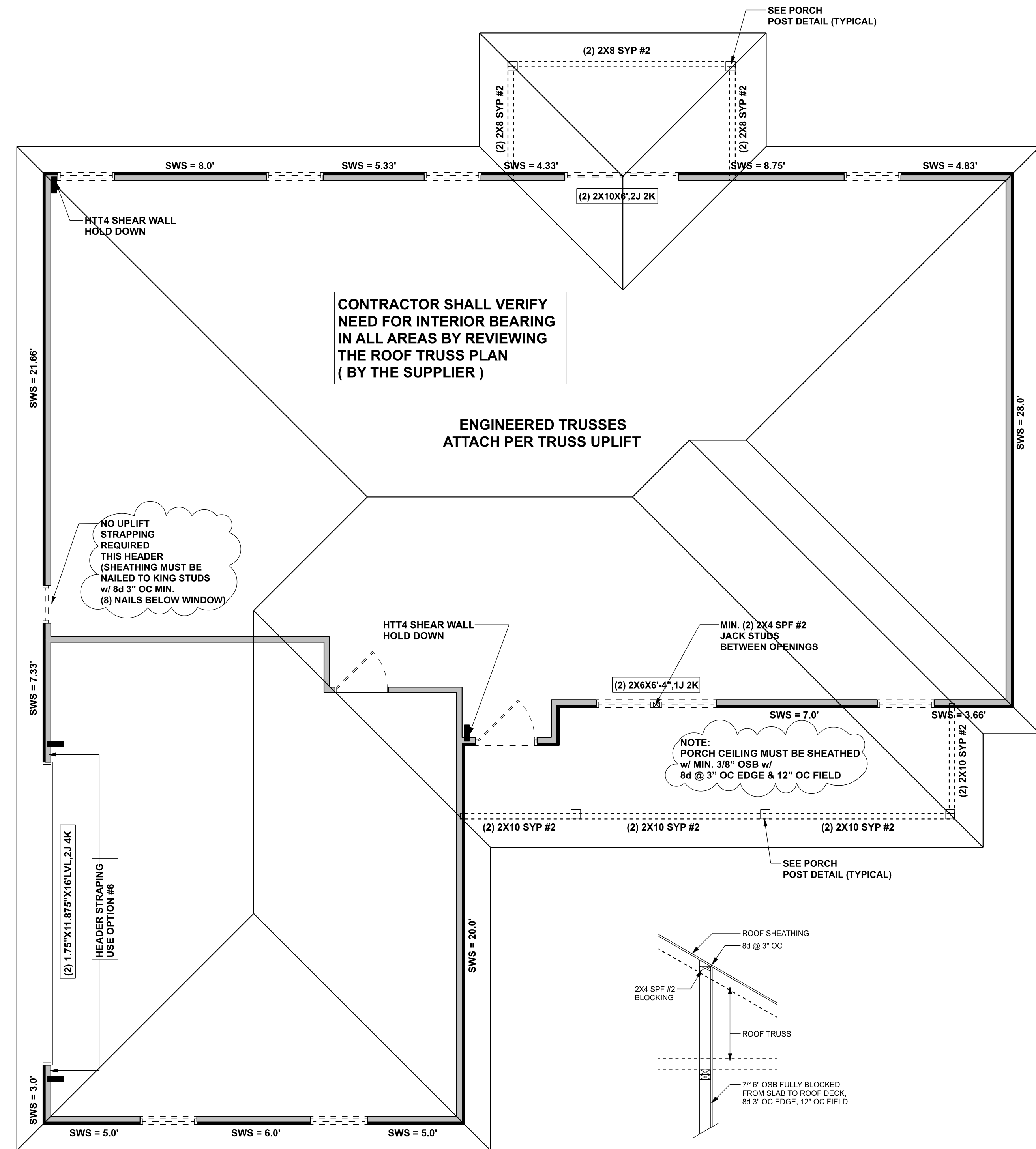

**ALTERNATE IF TRUSSES ARE PERPENDICULAR TO SHEARWALL**

NOTE: IF THE ABOVE DETAIL IS USED ON THE FRONT PORCH WALL THE FRONT PORCH CEILING DOES NOT NEED TO BE SHEATHED

**STRUCTURAL PLAN**  
SCALE: 1/4" = 1'-0"

**STRUCTURAL PLAN NOTES**

- SN-1 DIMENSIONS ON STRUCTURAL SHEETS ARE NOT EXACT. REFER TO ARCHITECTURAL FLOOR PLAN FOR ACTUAL DIMENSIONS
- SN-2 PERMANENT TRUSS BRACING IS TO BE INSTALLED AT LOCATIONS AS SHOWN ON THE SEALED TRUSS DRAWINGS. LATERAL BRACING IS TO BE RESTRAINED PER BCSI-03, BCSI-B1, BCSI-B2, & BCSI-B3. BCSI-B1, BCSI-B2, & BCSI-B3 ARE FURNISHED BY THE TRUSS SUPPLIER, WITH THE SEALED TRUSS PACKAGE

**UNLESS NOTED OTHERWISE (MINIMUM REQUIREMENTS)**  
**\*\*\*SEE STRUCTURAL PLAN FOR ANY SPECIFIC CALL OUTS\*\*\***

BEAM / HEADERS (SIZE)	ALL LOAD BEARING FRAME WALL & PORCH HEADERS SHALL BE A MINIMUM OF (2) 2X6 SP #2 (UNO)
HEADERS (JACK & KING STUDS)	ALL LOAD BEARING FRAME WALL HEADERS SHALL HAVE (1) JACK STUD & (1) KING STUD EACH SIDE (UNO)
HEADERS (STRAPPING)	ALL HEADERS w/ UPLIFT TO BE STRAPPED OR SCREWED DOWN w/ MIN. OPTION #1 OR OPTION #3 (SEE DETAIL ON SHEET S-1) (U.N.O.) 1/2" X 10" ANCHOR BOLT w/ 3" X 3" X 1/4" WASHER MUST BE LOCATED WITHIN 6" OF KING STUD @ ALL DOOR LOCATIONS (U.N.O.)
JACK STUDS UNDER GIRDER TRUSS	USE ONE JACK STUD GIRDER SUPPORT PER 2000 LB LOAD

**HEADER LEGEND**

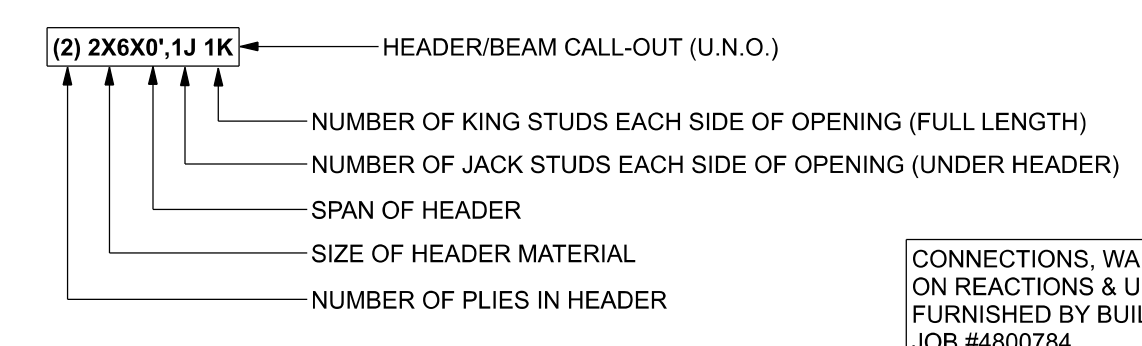

**ACTUAL vs REQUIRED SHEARWALL**

	TRANSVERSE	LONGITUDINAL
ACTUAL	23037 LBF	10996 LBF
REQUIRED	8710 LBF	8900 LBF

CONNECTIONS, WALL & HEADER DESIGN IS BASED ON REACTIONS & UPLIFTS FROM TRUSS ENGINEERING FURNISHED BY BUILDER. BUILDERS FIRST SOURCE JOB #4800784

**LUMBER SIZE & GRADE MINIMUM REQUIREMENTS**

RISE BOARD	2X6 SYP #2
RAFTER SPANS 27'-0" OR LESS	2X4 SYP #2
FURLINS / LATERAL BRACING	2X4 SPF #2
SLEEPERS	2X (WIDTH OF RAFTER SEAT CUT) SPF #2 OR 2 DIMENSIONAL 2X4 SYP #2
CRIPPLES & BLOCKING	2X4 SPF #2 OR BETTER
TRUSS BELOW	SEE TRUSS DESIGN - SOUTHERN PINE MATERIAL

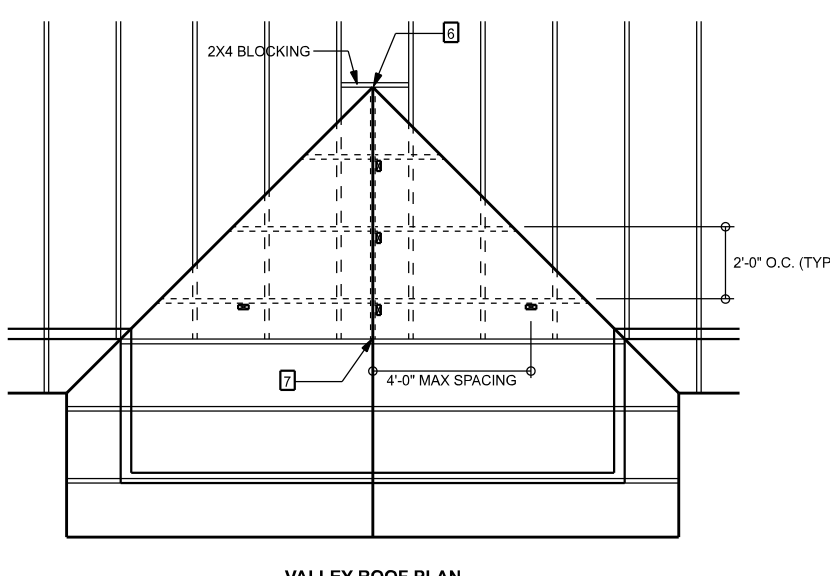

**VALLEY ROOF PLAN MEMBER LEGEND**

- TRUSS
- TRUSS UNDER VALLEY FRAMING
- VALLEY RAFTER OR RIDGE
- CRIPPLE

**CONNECTION REQUIREMENT NOTES**

1 2X4 RAFTERS TO RIDGE	4 - 131 x 3 TOE NAILS
2 CRIPPLE TO RIDGE	4 - 131 x 3 FACE NAILS
3 CRIPPLE TO RAFTERS	4 - 131 x 3 FACE NAILS
4 RAFTER TO SLEEPER OR BLOCKING	4 - 131 x 3 TOE NAILS
5 SLEEPER TO TRUSS	4 - 131 x 3 FACE NAILS EACH TRUSS
6 RIDGE BOARD TO ROOF BLOCK	4 - 131 x 3 TOE NAILS
7 RIDGE BOARD TO TRUSS	4 - 131 x 3 TOE NAILS
8 FURLIN TO TRUSS (TYP)	4 - 131 x 3 TOE NAILS
9 FURLIN TO TRUSS IF CRIPPLE IS ATTACHED TO FURLIN	4 - 131 x 3 TOE NAILS
10 TRUSS TO BLOCKING	4 - 131 x 3 END NAILS
11 CRIPPLE TO TRUSS	4 - 131 x 3 FACE NAILS
12 CRIPPLE TO FURLIN	4 - 131 x 3 FACE NAILS

**GENERAL NOTES**

MAXIMUM RAFTER SPANS: 27'-0" FOR 2X4, 30'-0" FOR 2X6 SYP #2 OR SYP #2  
MAXIMUM ROOF AREA PER SUPPORT: 1000 SQ FT. EXAMPLE: 4'-0" O.C. X 4'-0" SPAN  
RIGID IN SPANS 2'-0" AND 4'-0" SPANS: 1/2" OSB OR 2" X 8" SPAN + HDI  
FURLIN REQUIRED: 2" O.C. IF EXISTING SHEATHING IS REMOVED  
FURLINS SHOULD OVERLAP SHEATHING ONE TRUSS SPACING MINIMUM IN CASES THAT THIS IS NON-TYPICAL. CRIPPLE SHEATHING MINIMUM OF 8" AND NAIL UPWARDS THROUGH SHEATHING INTO FURLIN WITH A MINIMUM OF 4-8 COMMON WIRE NAILS  
THIS DRAWING APPLIES TO VALLEYS WITH THE FOLLOWING CONDITIONS:  
-SPAN OVER VALLEY BETWEEN HEADERS 4'-0" OR LESS  
-MAXIMUM WIND SPEED: 130 MPH  
-MAXIMUM WIND HEIGHT: 15'-0" OR LESS  
-MAXIMUM WIND EXPOSURE: 15'-0" OR LESS  
-MAXIMUM TOTAL LOADING: 40 psf  
-MINIMUM FLOOR FINISH: 10 psf  
-EXPOSURE CATEGORY: "C", "I" = 1.0, K1 = 1.0  
-ENCLOSED BUILDING

**CRIPPLE, BRACING & BLOCKING NOTES**

2X4 CONTINUOUS LATERAL BRACE (CLB) MIN. IS REQUIRED FOR CRIPPLES 2'-0" TO 10'-0" LONG NEEDED TO: 1-100 NAILS OR 2X4 1" OR SCAB BRACE NAIL TO PLATE EDGE OR CRIPPLE WITH 1/2" X 10" ANCHOR BOLT OR SCAB MUST BE 80% OF CRIPPLE LENGTH. CRIPPLES OVER 10'-0" LONG REQUIRE TWO CLB ON BOTH SIDES w/ 1" OR SCAB. USE STEEL GRADED LUMBER 4" X 6" OR COMMON NAILS  
NARROW EDGE OF CRIPPLE CAN FACE RIDGE OR RAFTER, AS LONG AS THE PROPER NUMBER OF NAILS ARE INSTALLED INTO RIDGE BOARD  
INSTALL BLOCKING UNDER CRIPPLES IF SLEEPERS ARE NOT USED  
INSTALL BLOCKING UNDER CRIPPLES IF CRIPPLES FALL BETWEEN LOWER TRUSS TOP CHORDS AND LATERAL BRACING IS NOT USED  
APPLY ALL NAILING IN ACCORDANCE TO NDS-199 SECTION 12. NAILS ARE COMMON WIRE NAILS UNLESS NOTED OTHERWISE

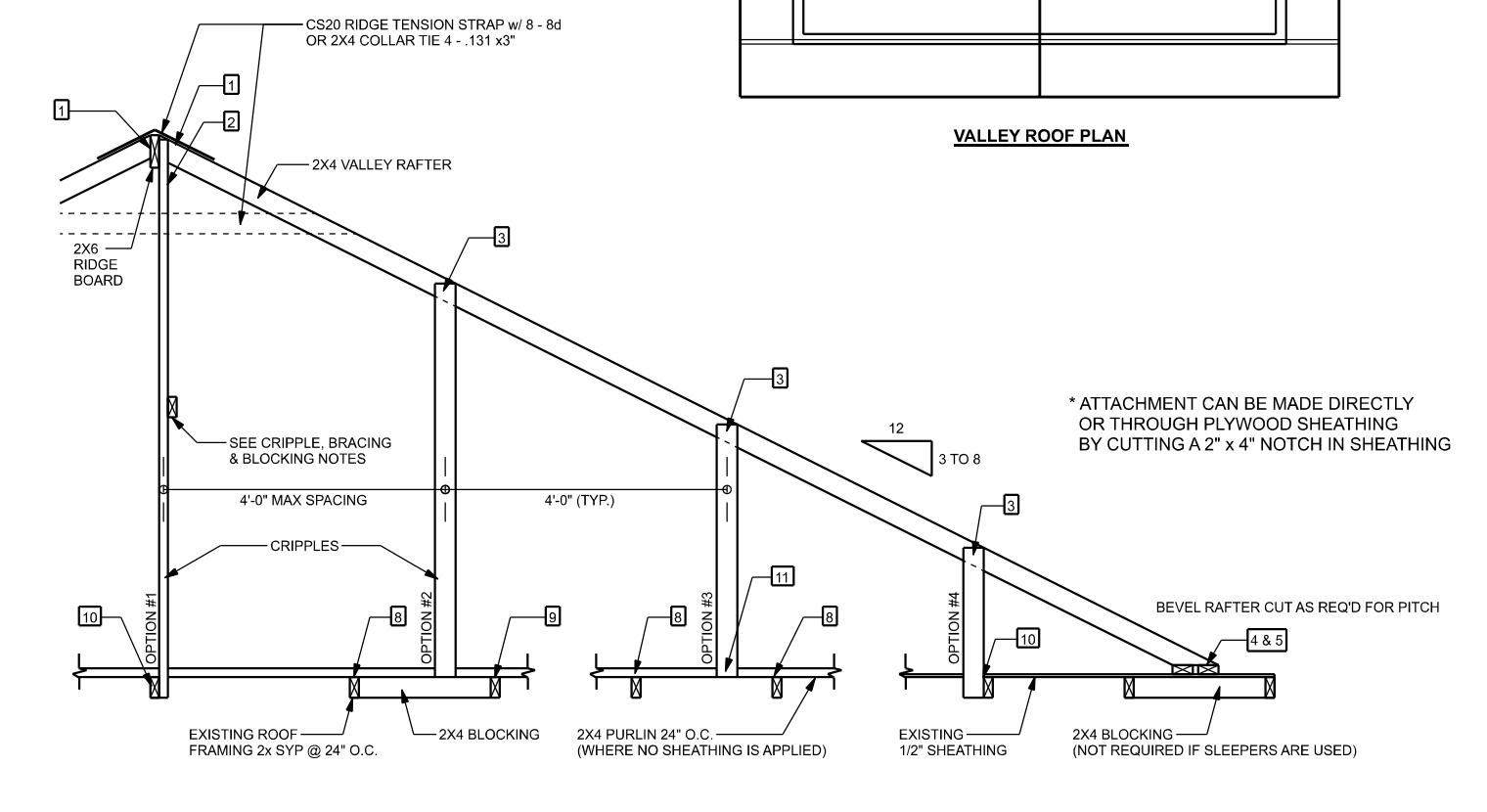

**ROOF OVER FRAMING & BRACING DETAIL**  
SCALE: N.T.S.

DWC Contracting, LLC

Spec Home - Lot 97 Emerald Cove

PROJECT ADDRESS:  
Lot 97 Emerald Cove  
Columbia County, FL

FL PE 53915  
This item has been digitally signed and sealed by Mark Disoway P.E. on digital signature date. Printed copies of this document are not considered signed and sealed and the signature must be verified on any electronic copies.

**DIMENSIONS:**  
Stated dimensions supercede scaled dimensions. Refer all questions to Mark Disoway P.E. for resolution. Do not proceed without clarification.

**COPYRIGHTS AND PROPERTY RIGHTS:**  
Mark Disoway P.E. hereby expressly reserves its common law copyrights and property right in these instruments of service. This document is not to be reproduced, altered or copied in any form or manner without first the express written permission and consent of Mark Disoway.

**CERTIFICATION:** I hereby certify that I have examined this plan, and that the applicable portions of the plan, relating to wind engineering comply with the 8th Edition Florida Building Code Residential (2023) to the best of my knowledge.

**LIMITATION:** This design is valid for one building, at specified location.

Mark Disoway P.E.  
163 SW Midtown Place  
Suite 103  
Lake City, Florida 32025  
386.754.5419  
disowaydesign@gmail.com

**JOB NUMBER:**  
260011

**S-3**  
OF 5 SHEETS